

Open Season Express

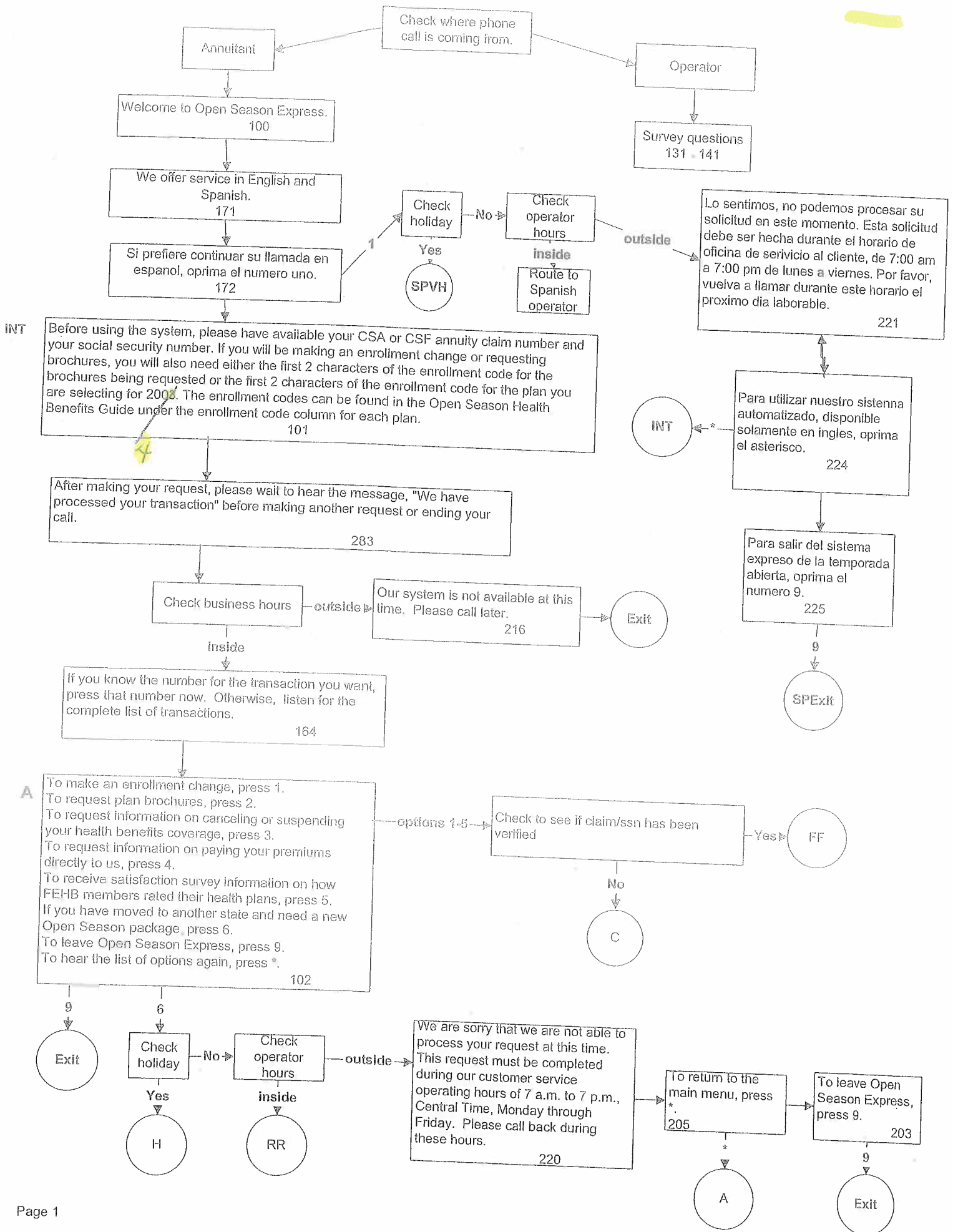

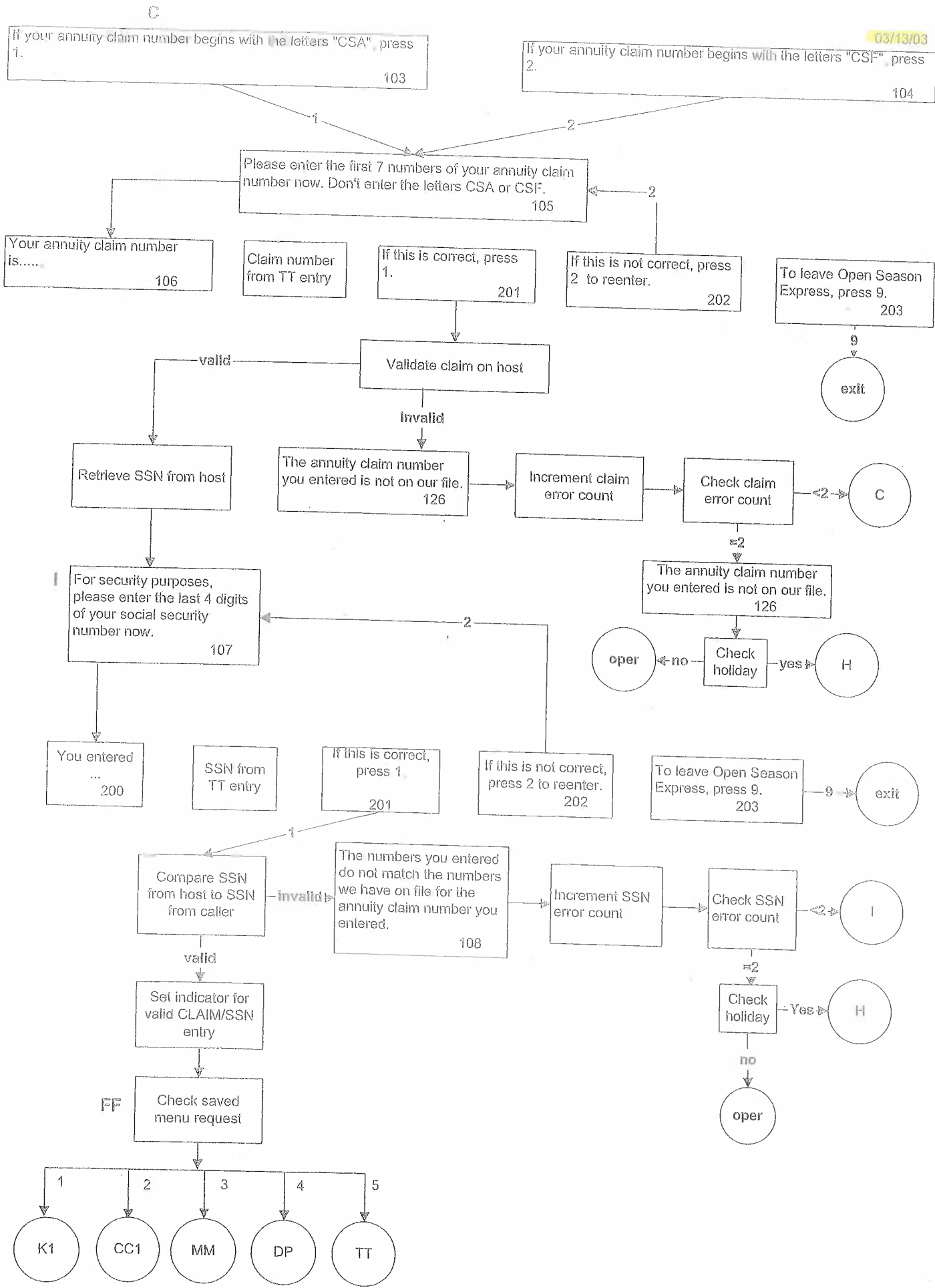

Enrollment Requests

03/13/03

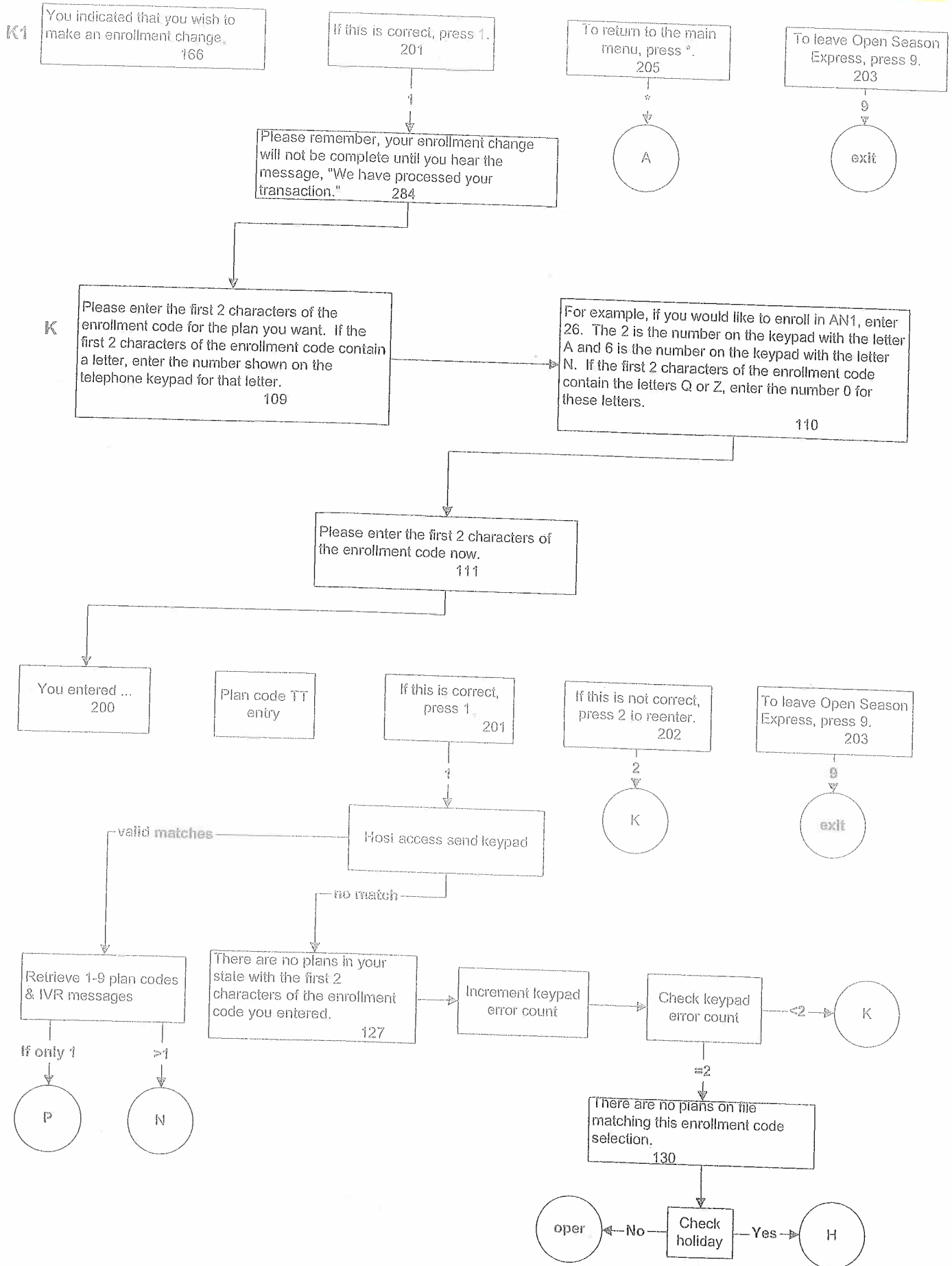

P

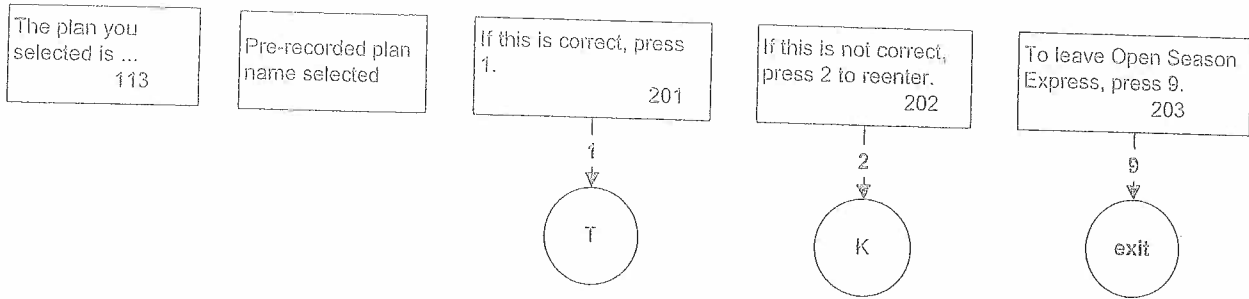

N

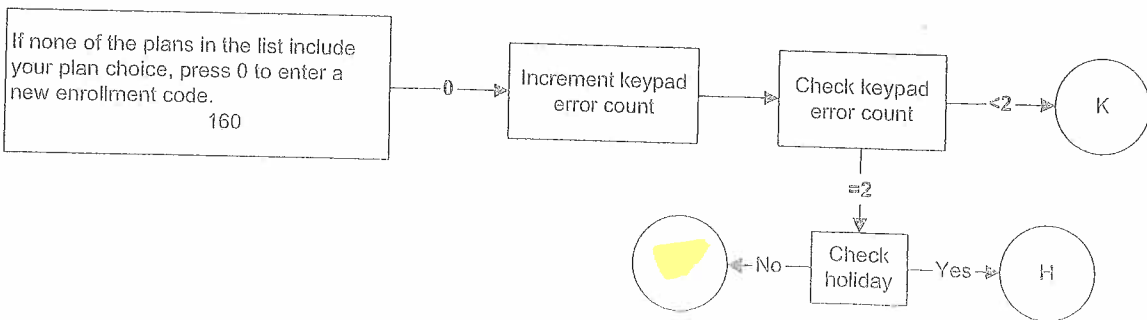
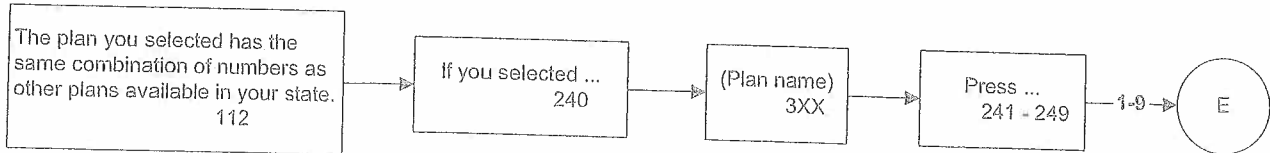

E

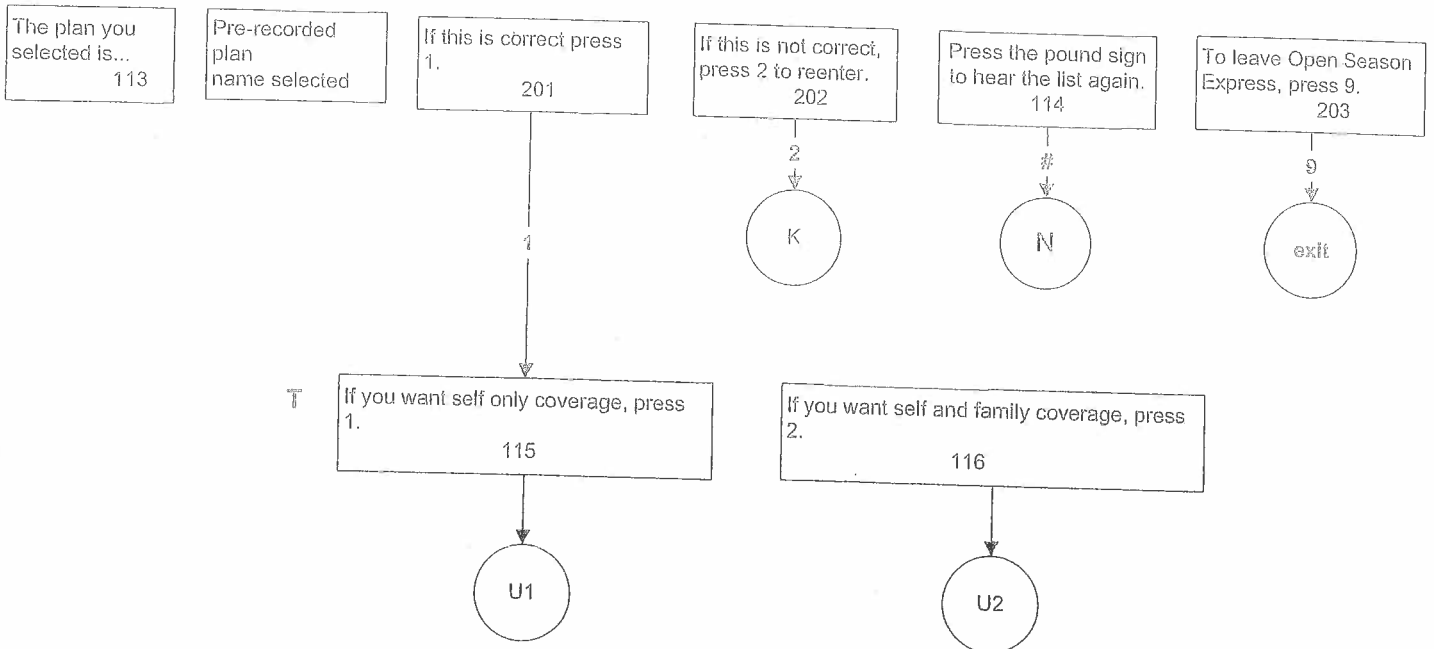

Enrollment Requests
self only

03/13/03

U1

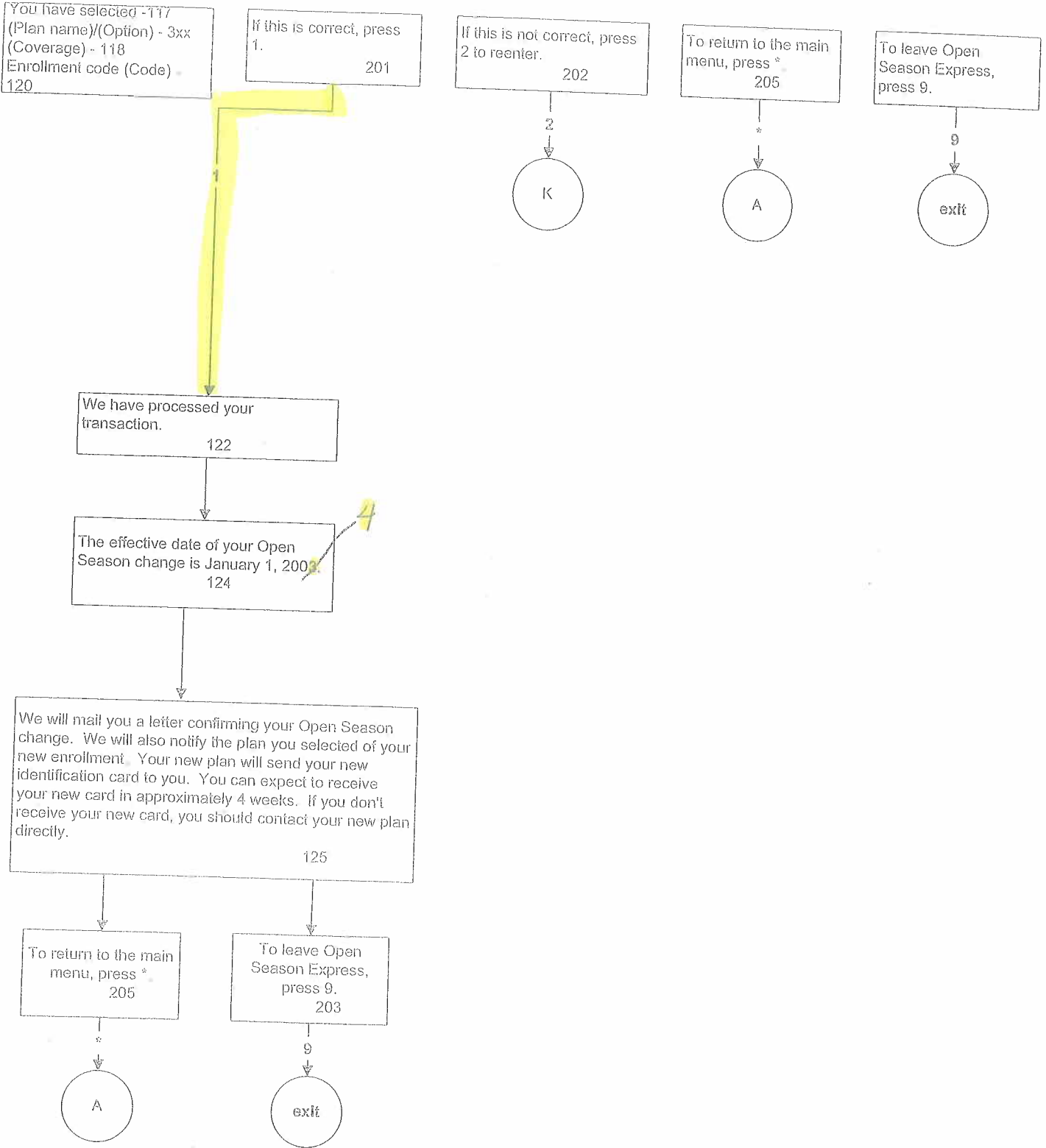

Enrollment Requests
self & family

03/13/03

U2

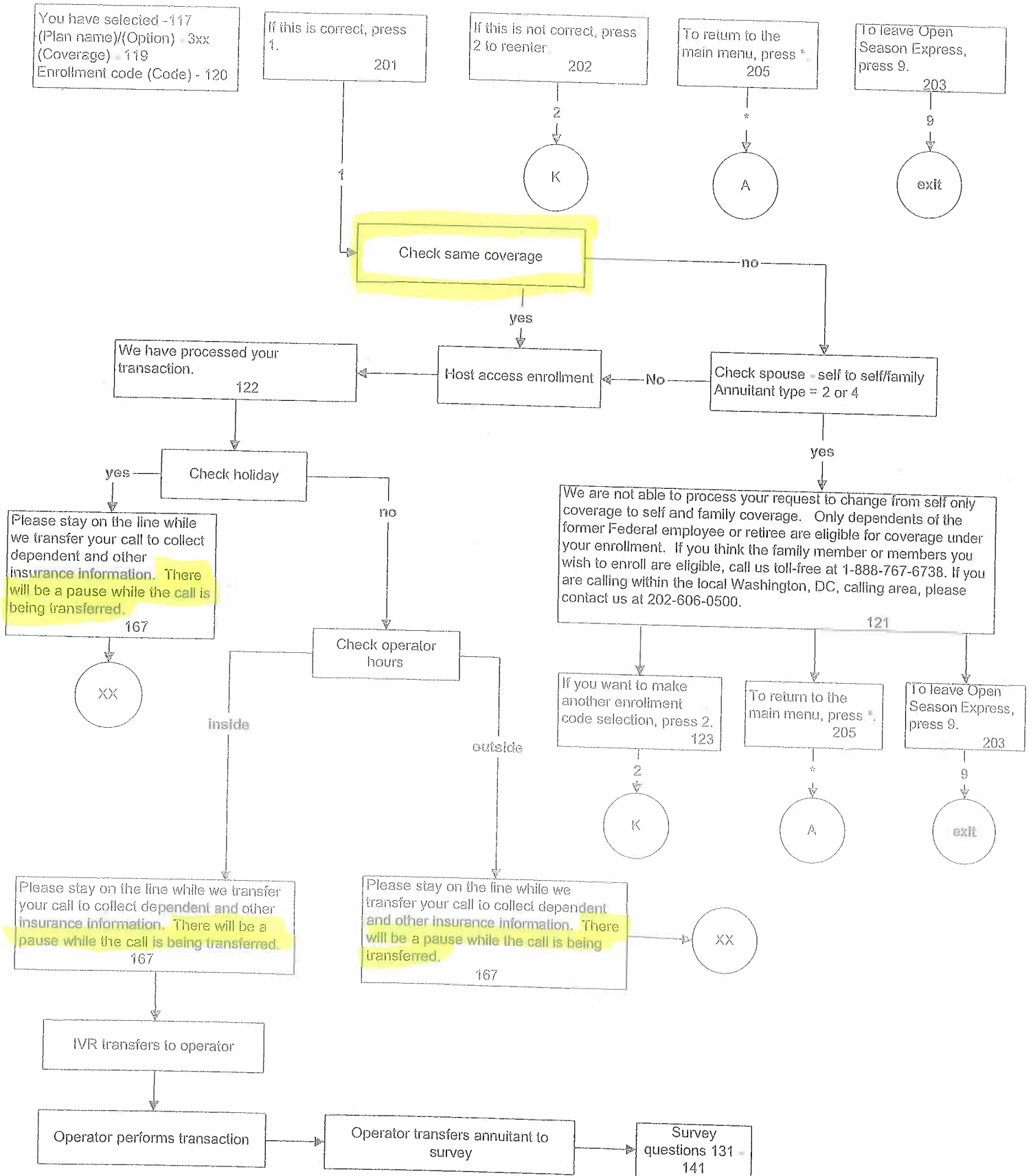

Brochure Requests

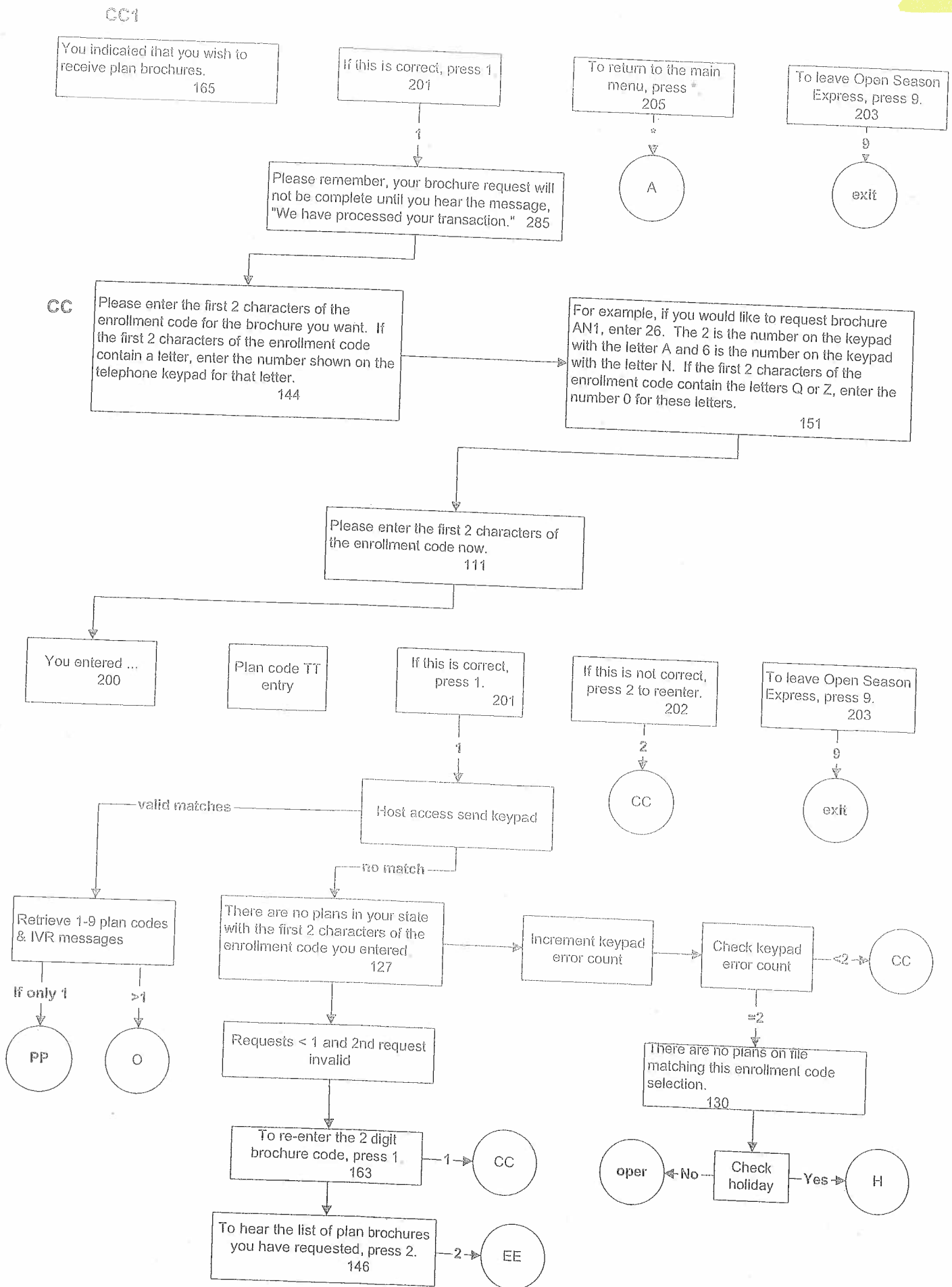

Brochure Requests

03/13/03

PP

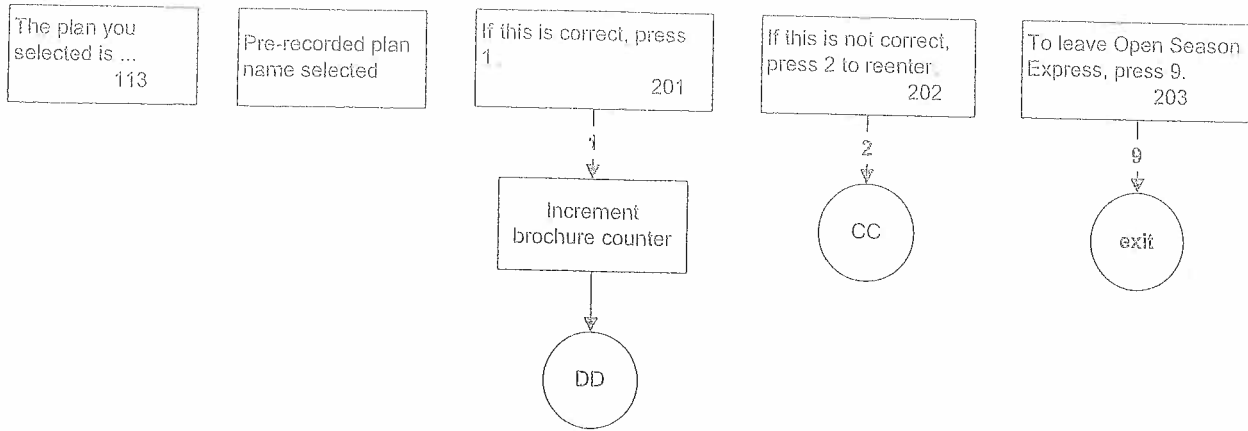

O

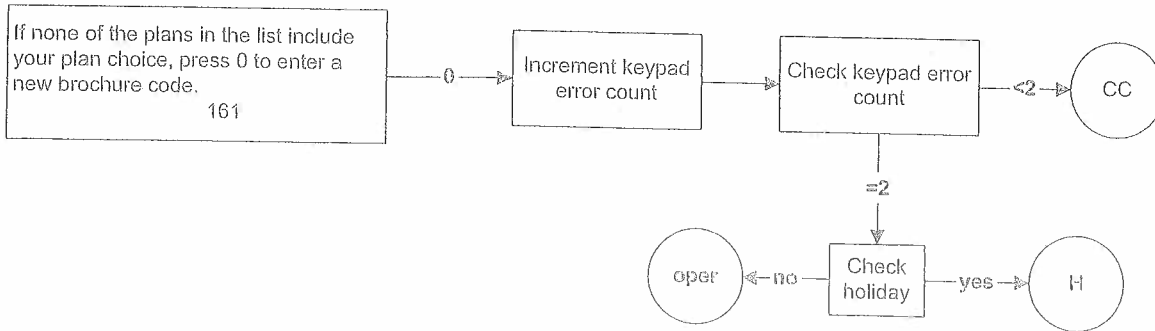
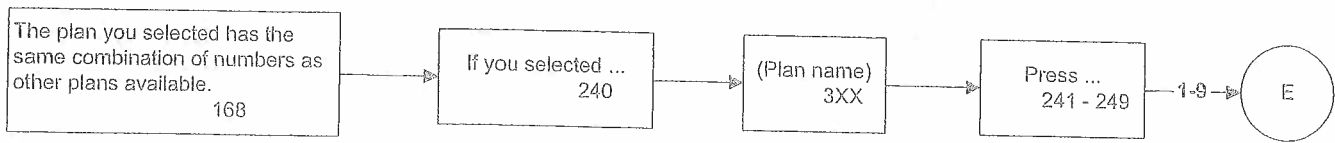

E

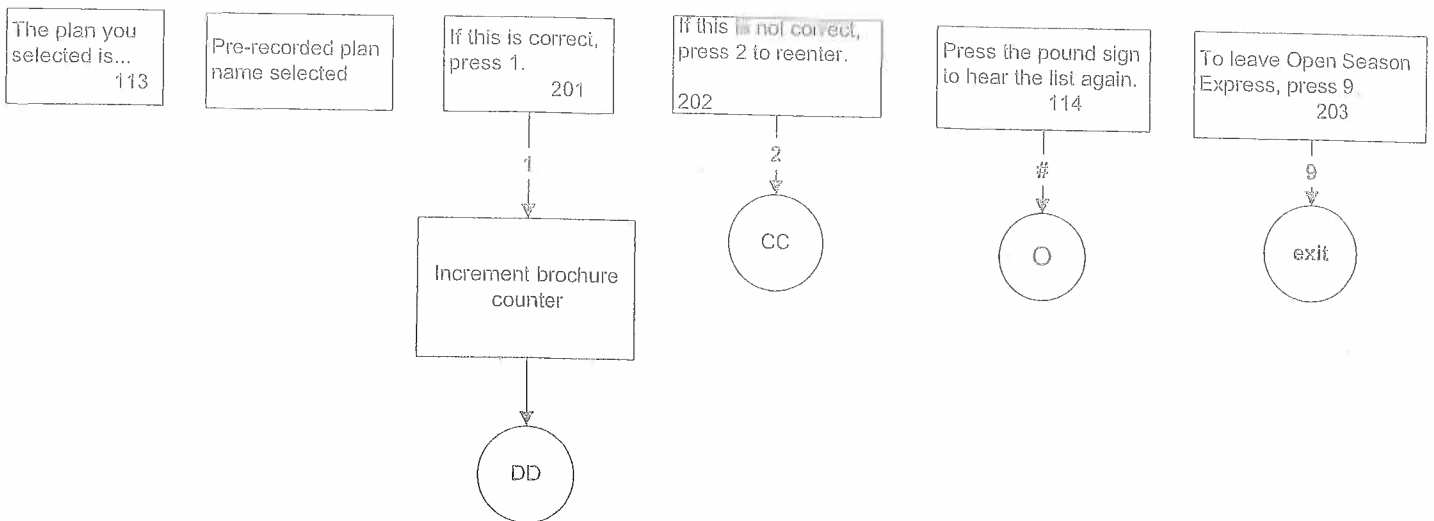

Brochure Requests

03/13/03

DD

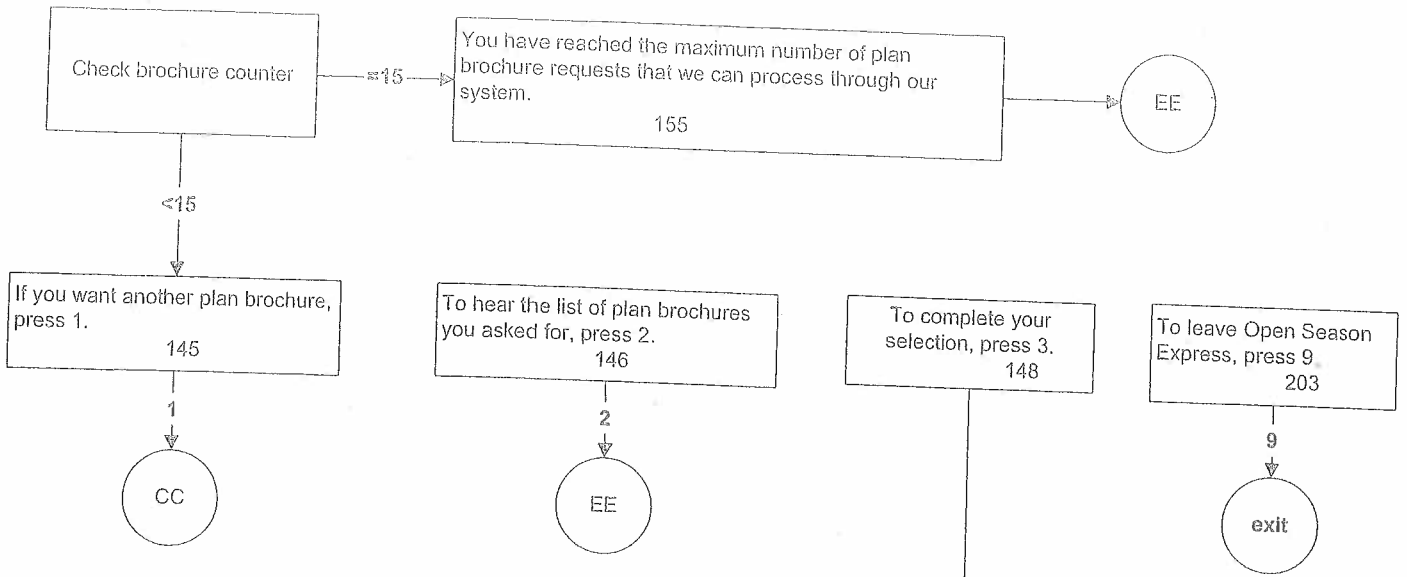

EE

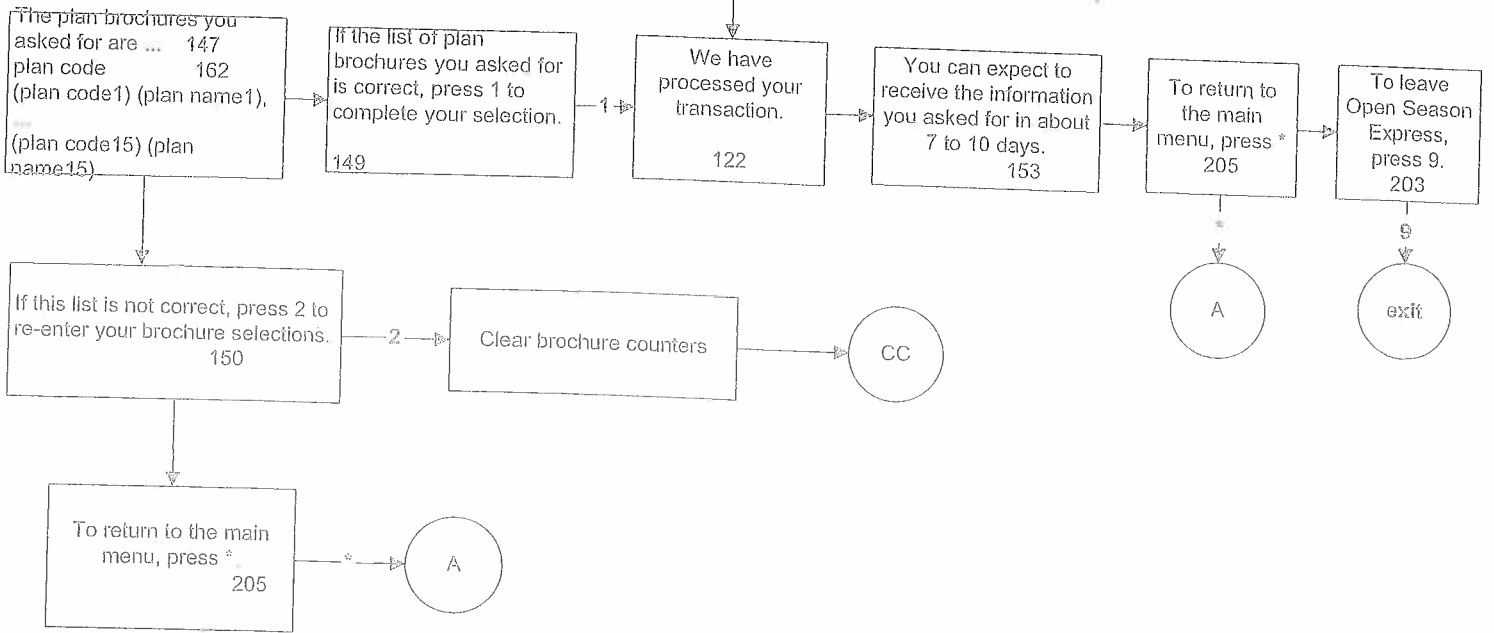

Premiums to OPM

DP

You indicated that you wish to receive information on how to pay your premiums directly to us. Please note this option is only available when your monthly annuity payment is not large enough to cover the cost of the monthly health benefits premium.
156

If this is correct, press 1.
201

To return to the main menu, press *
205

To leave Open Season Express, press 9.
203

Host Access. Send premium to OPM information request.

*
A

9
exit

We have processed your transaction.
122

You can expect to receive the information you asked for in about 7 to 10 days.
153

To return to the main menu, press *
205

To leave Open Season Express, press 9.
203

*
A

9
Survey questions
131 - 141

Thank you for using Open Season Express.
204

Suspend/Cancel

03/13/03

MM

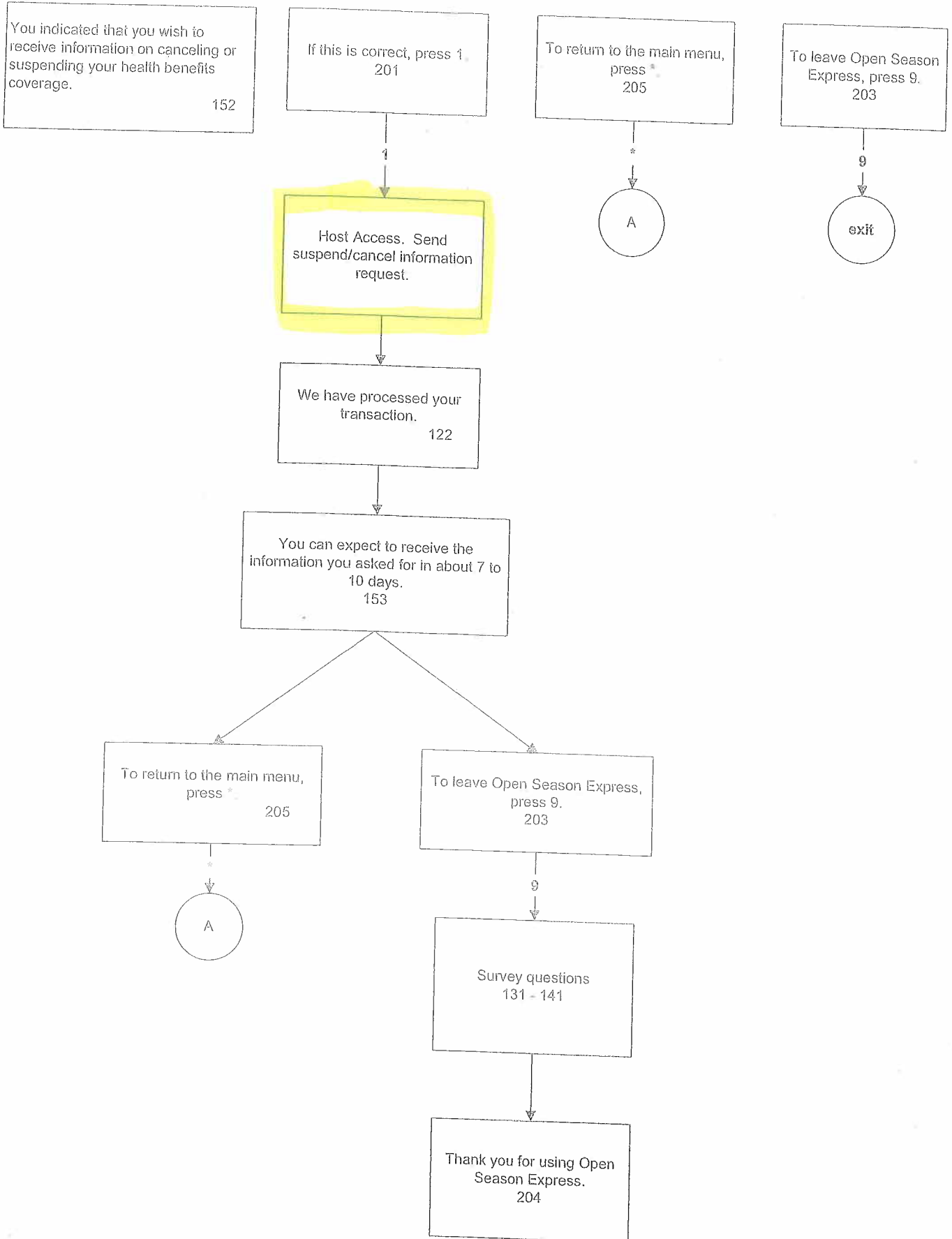

Health Plan Survey

03/13/03

TT

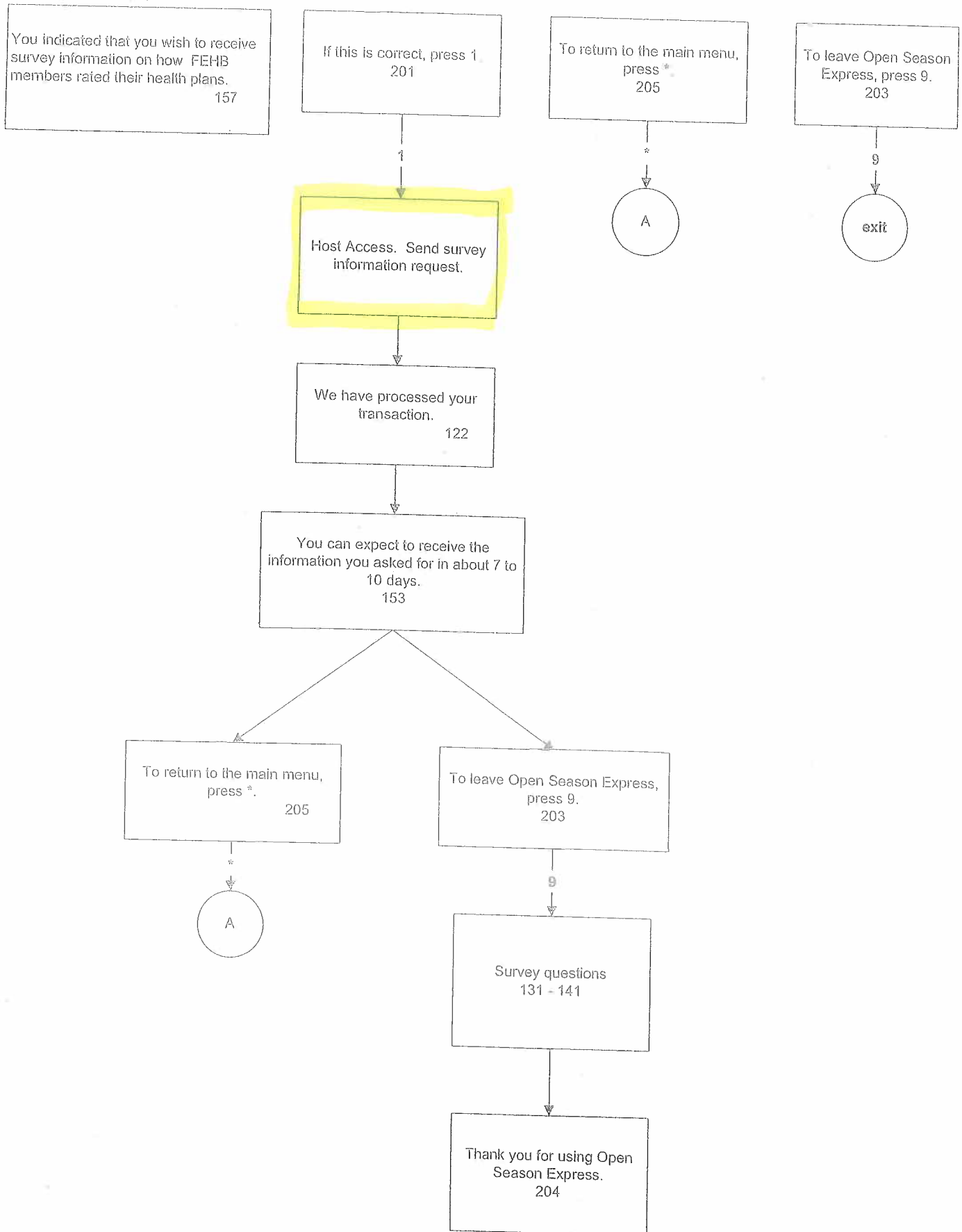

Federal Holiday

03/13/03

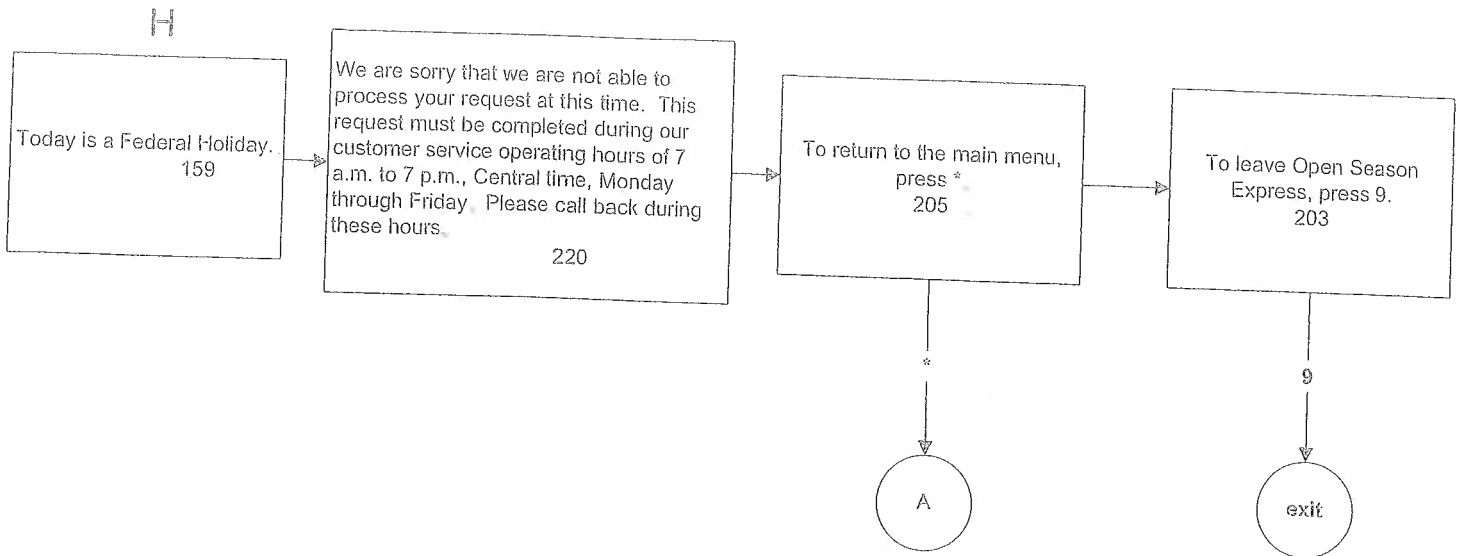

Spanish version: Federal Holiday

SPVH

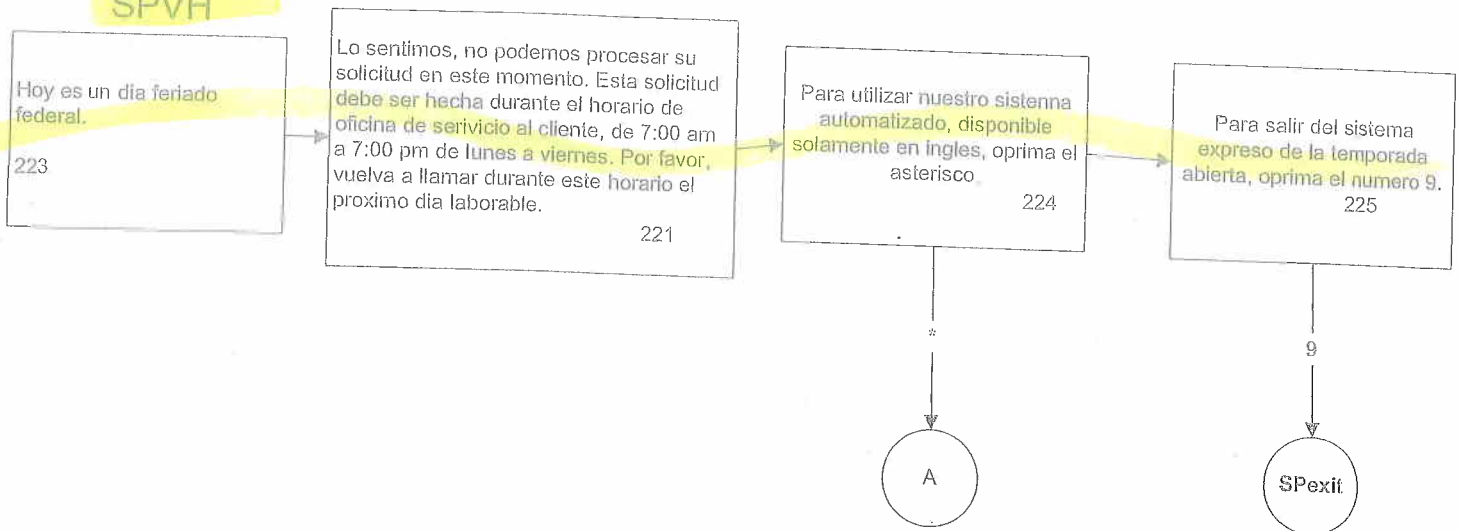

Address Change

03/13/03

RR

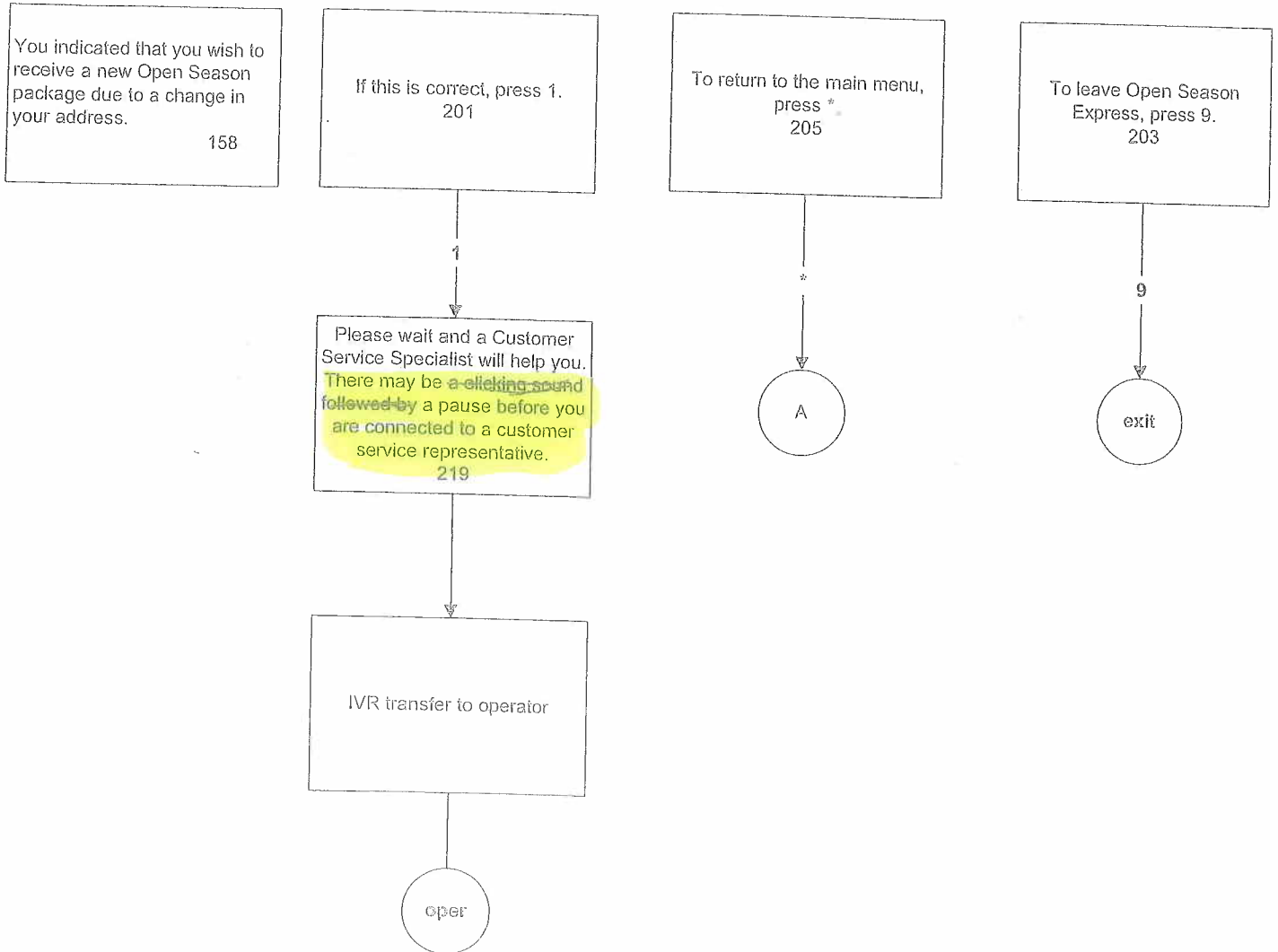

Exit Routine

03/13/03

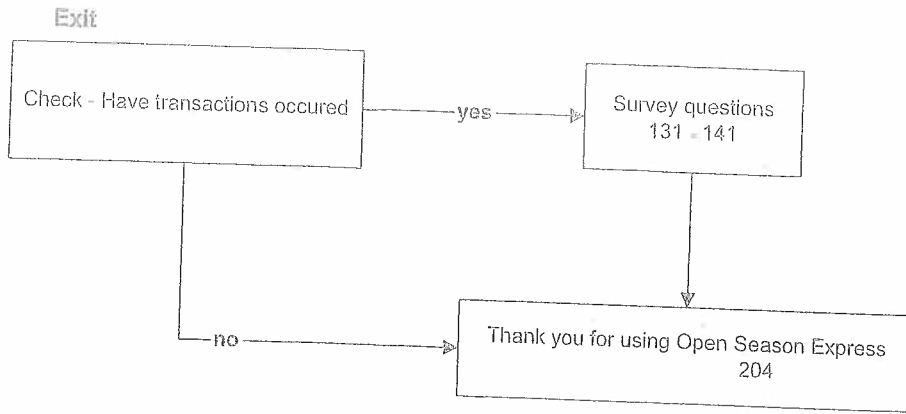

Spanish version Exit

SPExit

Gracias por utilizar el sistema expreso de la
temporada abierta.
222

Transfer to operator

03/13/03

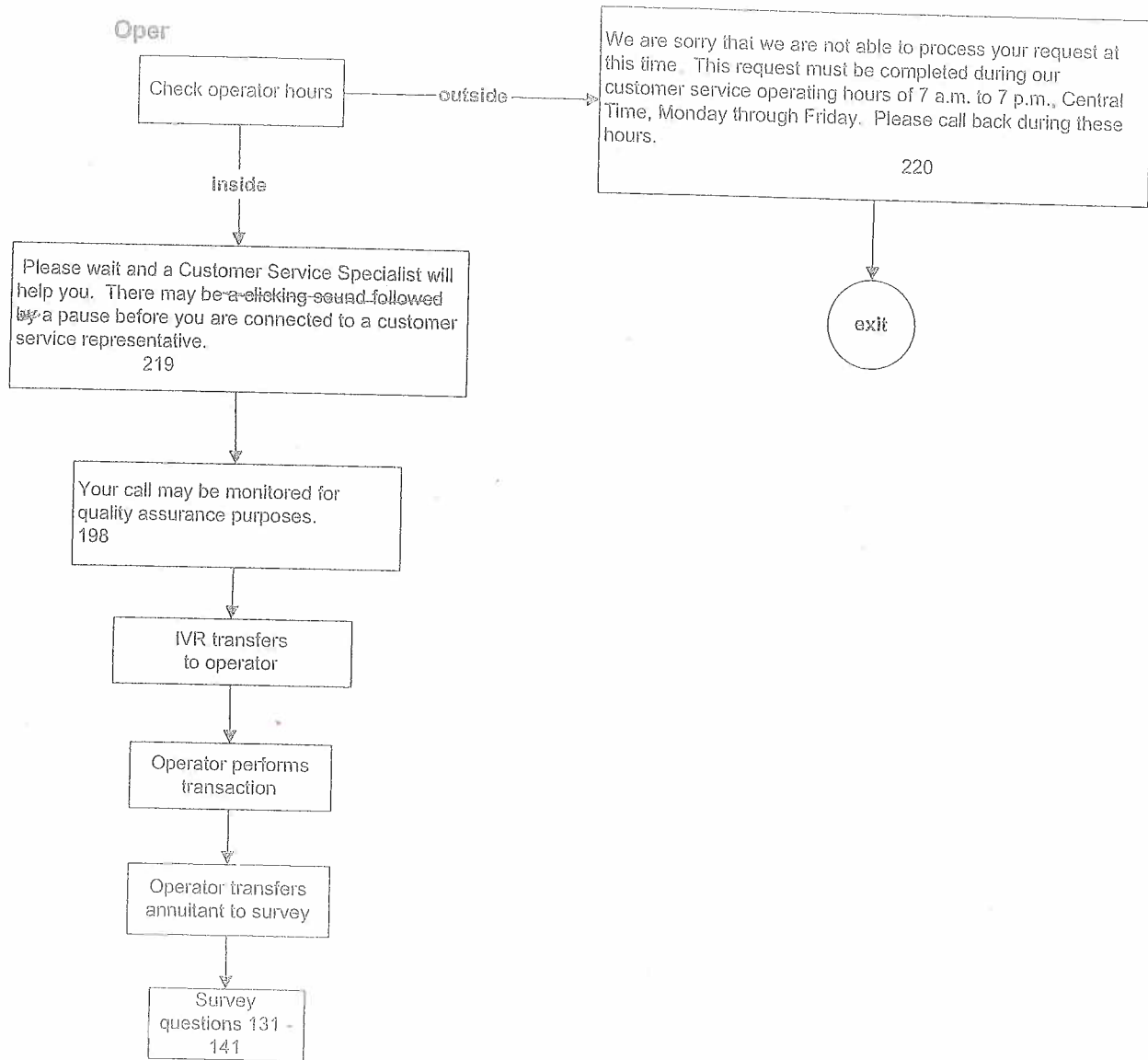

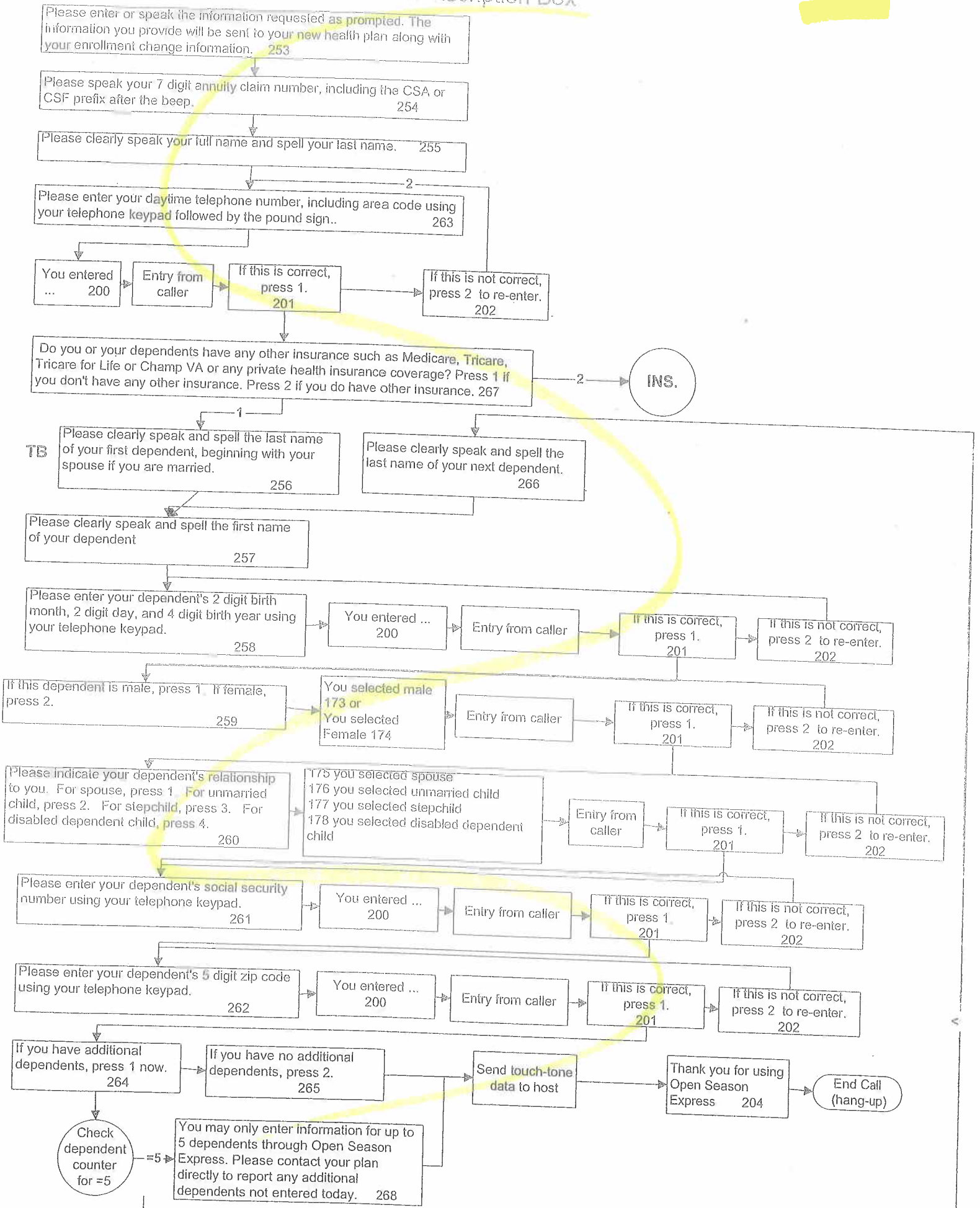

ins

Transcription Box con't

Your Federal Health Plan will need to coordinate benefits with any other health insurance plans you or your dependents may have. 269

270 Do you have Medicare coverage? Press 1 if you don't have Medicare, press 2 if you have both Medicare A and B, press 3 if you have Medicare A only or press 4 if you have Medicare B only. 270

entry from caller

1, 2

Does your spouse have Medicare coverage? Press 1 if your spouse doesn't have Medicare coverage, press 2 if your spouse has both Medicare A and B, press 3 if your spouse has Medicare A only or press 4 if your spouse has Medicare B only. 287

entry from caller

1, 2

Do you or your spouse have Tricare, Tricare for Life, or Champ VA coverage? Press 1 if you have Tricare, Tricare for Life or ChampVA. Press 2 if you don't have Tricare, Tricare for Life or Champ VA coverage. 289

entry from caller

1

Please speak and spell the last name and first name of the Tricare, Tricare for Life, or Champ VA policyholder. 290

2

Do you or your dependents have a private insurance plan, press 1 if you do not have private insurance, press 2 if you do. 291

entry from caller

1

2

Please speak the name of the private plan and speak and spell the last and first name of the private insurance policyholder. 292

TB

Survey Questions

Your opinion about this system is very important to us. In our efforts to better serve you we ask that you stay on the line and answer a few short questions that will take less than a minute to answer. Your participation will help us improve our customer service. 131

