

ICR Number XXXX.XX  
OMB Control Number: XXXX-XXXX  
Expiration Date: mm/dd/yyyy

Plant ID: **Insert Plant ID**  
Plant Name: **Insert Plant Name**



## Steam Electric Questionnaire Second FRN Version Draft

### PART D - POND/IMPOUNDMENT SYSTEMS AND OTHER WASTEWATER TREATMENT OPERATIONS

#### Table of Contents

| <b>Section Title</b>   | <b>Tab Name</b>     |
|--|---------------------|
| Part D Instructions  | Part D Instructions |
| Plant Pond/Impoundment Systems and Wastewater Treatment Systems        | Part D Section 1    |
| Pond/Impoundment System and Wastewater Treatment System Identification | Part D Section 2    |
| Wastewater Treatment Diagram   | Part D Section 3.1  |
| Wastewater Treatment Wastewater Flows                                  | Part D Section 3.2  |
| Active/Inactive/Open and Planned Pond/Impoundment Unit Information     | Part D Section 4.1  |
| Closed Pond/Impoundment Unit Information                               | Part D Section 4.2  |
| Wastewater Treatment Unit Information - System Level                   | Part D Section 5.1  |
| Wastewater Treatment System Chemical Addition                          | Part D Section 5.2  |
| Pond/Impoundment System and Wastewater Treatment System Costs          | Part D Section 6.1  |
| Pond/Impoundment System and Wastewater Treatment System Equipment      | Part D Section 6.2  |
| Part D Comments  | Part D Comments     |
| Steam Electric Questionnaire Code Tables                               | Code Tables         |

Plant ID: Insert Plant ID  
Plant Name: Insert Plant Name

## PART D. POND/IMPOUNDMENT SYSTEMS AND OTHER WASTEWATER TREATMENT OPERATIONS

### INSTRUCTIONS

Part D requests information about all ponds/impoundments used (or planned to be used or under construction/installation by December 31, 2020) for the storage, treatment, and/or disposal of process wastewater, residues, or by-products (or sludges or water streams containing the residues or by-products) from the combustion of coal, petroleum coke, or oil, including but not limited to fly ash, bottom ash, boiler slag, or flue gas emission control residues. Additionally, Part D requests information about wastewater treatment systems, other than pond/impoundment systems, for the treatment of wastewaters from ash handling or FGD operations that are located at the plant or are planned to be located at the plant. Complete Part D if you operate one or more systems, or if you are currently constructing/installing, or planning to construct/install one or more systems by December 31, 2020.

Refer to the following definitions throughout Part D.

A "**pond/impoundment**" is defined as a natural topographic depression, man-made excavation, or diked area formed from earthen materials or man-made materials or a combination of them, which is designed to hold an accumulation of liquid process wastes or process wastes containing free liquids, and which is not an injection well.

A "**pond/impoundment system**" is defined as a system consisting of one or more ponds/impoundments.

A "**wastewater treatment unit**" is defined as a unit operation used to remove pollutants from process wastewater. Wastewater treatment units include, but are not limited to: ponds/impoundments, chemical precipitation, pH adjustment, clarification, biological reactor, thickeners, filters, and constructed wetlands.

A "**wastewater treatment system**" is defined as a combination of one or more "wastewater treatment units", other than ponds/impoundments, designed to achieve wastewater treatment.

**NOTE: If a pond/impoundment unit (as defined in Section 4.1) is part of a broader "wastewater treatment system" containing non-pond units (e.g., a pond/impoundment unit in a biological wastewater treatment system), it is not considered part of a pond/impoundment system.**

Throughout Part D, information is requested for pond/impoundment and wastewater treatment units and systems that are under construction/installation, or planned to be under construction/installation by December 31, 2020. Provide design information, or best engineering estimates as necessary, for these planned systems/units. Additionally, indicate "NA" if the information requested is not applicable for planned systems/units (e.g., a question that requests flow rate data for year 2009).

As you are completing the electronic form, note the following: When you enter your plant name and plant ID on the Part D Table of Contents tab, all name and ID fields throughout Part D will automatically populate. Refer to the overall questionnaire instructions, the glossary, and the acronym list for assistance with completing Part D.

Please provide all free response answers in the highlighted yellow areas. Throughout Part D, you may need to make copies of certain sections/questions. Instructions are provided throughout Part D regarding making copies. Note that pond/impoundment system (and unit) and wastewater treatment system ID's must be populated on the copied tab or section, located in the upper right corner under "Plant ID" and "Plant Name", in order to correlate the requested information with the pond/impoundment or wastewater treatment system.

Use the Part D Comments tab to do the following: provide additional information as requested in certain questions within Part D; indicate atypical data (e.g., if 2009 information is not representative of normal operations); and note methods used to make best engineering estimates in the event that exact data are not available.

Plant ID: Insert Plant ID  
Plant Name: Insert Plant Name

**Part: D**  
**Section Title: 1. Plant Pond/Impoundment Systems and Wastewater Treatment Systems**

**CBI?**  
 Yes

**D1-1.** Have you used, do you use, OR do you plan to use (or begin construction/installation of) by December 31, 2020 any *ponds/impoundments* for the storage, treatment, and/or disposal of *process wastewater, residues*, or by-products (or *sludges* or water streams containing the residues or by-products) from the combustion of coal, petroleum coke, or oil, including but not limited to *fly ash, bottom ash*, boiler slag, or flue gas emission control residues?

Note: This includes ponds/impoundments located on non-adjoining property that are under the operational control of the plant.

- Yes
- No

**CBI?**  
 Yes

**D1-2.** Do you operate OR plan to operate (or begin construction/installation of) by December 31, 2020 any wastewater treatment systems, other than pond/impoundment systems, for the treatment of process wastewaters from ash handling or FGD operations?

Note: This includes systems located on non-adjoining property that are under the operational control of the plant.

- Yes
- No



**If you answered "No" to both Questions D1-1 and D1-2, do NOT complete the remainder of Part D. Skip to the next Questionnaire Part. Otherwise, continue to Part D Section 2.**

Plant ID: Insert Plant ID  
Plant Name: Insert Plant Name**Part: D****Section Title:** 2. Pond/Impoundment System and Wastewater Treatment System Identification

**Instructions:** Complete Section 2 (Questions D2-1 through D2-7) for *pond/impoundment systems* and/or *wastewater treatment systems* that the plant operates and/or plans to operate (or begin construction/installation of) by December 31, 2020, including those located on non-adjointing property, for the treatment of *process wastewaters* from ash handling or FGD operations. Please provide all free response answers in the highlighted yellow areas.

**CBI?**  
 Yes**D2-1.** Has the plant been involved with any ash or FGD wastewater treatment studies (pilot- or full-scale), including studies on pond/impoundment systems, since 2000?

- Yes (Continue)  
 No (Skip to Question D2-4)

**CBI?**  
 Yes**D2-2.** Are any of these studies ongoing?

- Yes  
 No

**CBI?**  
 Yes**D2-3.** Was a summary and/or report describing/documenting the pilot- or full-scale study prepared (including internal and published reports)?

- Yes (Provide a copy of the summary/report)  
 No (Continue)

Provide a description of the pilot- or full-scale study. Note the types of treatment technologies studied, analytes measured in influent to and/or effluents from the wastewater treatment system, and the analytical methods used.

CBI?

 Yes

**D2-4.** List any ash or FGD wastewater treatment technologies that have been studied by the plant that are not covered by Questions D2-1 through D2-3 (e.g., those that have been studied in bench-scale studies).

CBI?

 Yes

**D2-5.** Do you operate OR plan to operate (or begin construction/installation of) by December 31, 2020 any systems, including those located on non-adjointing property, for the treatment of process wastewaters from ash handling or FGD operations?

Yes (Continue)

No (Skip to Section 4.1)

CBI?

 Yes

**D2-6.** Do you operate OR plan to operate (or begin construction/installation of) by December 31, 2020 any pond/impoundment systems, including those located on non-adjointing property, for the treatment of process wastewaters from ash handling or FGD operations?

Yes (Continue)

No (Skip to Question D2-7)

List these pond/impoundment systems in Table D-1. For each pond/impoundment system, EPA assigned a number (e.g., POND-1, POND-2) in Table D-1, which will be used throughout the remainder of the survey. In the "Plant Designation" column, provide the plant's name for each pond/impoundment system. In the "Individual Ponds/Impoundments Included in the Pond System" column, identify all pond/impoundment units from Table A-4 that are included in the pond system.

**NOTE: Do NOT include a pond/impoundment unit in Table D-1 if the pond/impoundment unit is or is planned to be part of a broader wastewater treatment system containing *non-pond wastewater treatment units* (e.g., pond/impoundment unit in a biological wastewater treatment system).**

**Table D-1. Plant Pond/Impoundment Systems**

| Pond/ Impoundment System ID                          | Plant Designation | Individual Pond/Impoundments (Identified in Table A-4) Included in the Pond/Impoundment System  |
|--|-------------------|---|
| <i>Active/Inactive/Open Pond/Impoundment Systems</i> |                   |   |
| POND-1   |                   | <input type="checkbox"/> SPD - 1 <input type="checkbox"/> SPD - 3 <input type="checkbox"/> SPD - 5 <input type="checkbox"/> SPD - 7 <input type="checkbox"/> SPD - 9 <input type="checkbox"/> SPD - 11 <input type="checkbox"/> SPD - 13  |
|  |                   | <input type="checkbox"/> SPD - 2 <input type="checkbox"/> SPD - 4 <input type="checkbox"/> SPD - 6 <input type="checkbox"/> SPD - 8 <input type="checkbox"/> SPD - 10 <input type="checkbox"/> SPD - 12 <input type="checkbox"/> SPD - 14 |
| POND-2   |                   | <input type="checkbox"/> SPD - 1 <input type="checkbox"/> SPD - 3 <input type="checkbox"/> SPD - 5 <input type="checkbox"/> SPD - 7 <input type="checkbox"/> SPD - 9 <input type="checkbox"/> SPD - 11 <input type="checkbox"/> SPD - 13  |
|  |                   | <input type="checkbox"/> SPD - 2 <input type="checkbox"/> SPD - 4 <input type="checkbox"/> SPD - 6 <input type="checkbox"/> SPD - 8 <input type="checkbox"/> SPD - 10 <input type="checkbox"/> SPD - 12 <input type="checkbox"/> SPD - 14 |
| POND-3   |                   | <input type="checkbox"/> SPD - 1 <input type="checkbox"/> SPD - 3 <input type="checkbox"/> SPD - 5 <input type="checkbox"/> SPD - 7 <input type="checkbox"/> SPD - 9 <input type="checkbox"/> SPD - 11 <input type="checkbox"/> SPD - 13  |
|  |                   | <input type="checkbox"/> SPD - 2 <input type="checkbox"/> SPD - 4 <input type="checkbox"/> SPD - 6 <input type="checkbox"/> SPD - 8 <input type="checkbox"/> SPD - 10 <input type="checkbox"/> SPD - 12 <input type="checkbox"/> SPD - 14 |
| POND-4   |                   | <input type="checkbox"/> SPD - 1 <input type="checkbox"/> SPD - 3 <input type="checkbox"/> SPD - 5 <input type="checkbox"/> SPD - 7 <input type="checkbox"/> SPD - 9 <input type="checkbox"/> SPD - 11 <input type="checkbox"/> SPD - 13  |
|  |                   | <input type="checkbox"/> SPD - 2 <input type="checkbox"/> SPD - 4 <input type="checkbox"/> SPD - 6 <input type="checkbox"/> SPD - 8 <input type="checkbox"/> SPD - 10 <input type="checkbox"/> SPD - 12 <input type="checkbox"/> SPD - 14 |
| POND-5   |                   | <input type="checkbox"/> SPD - 1 <input type="checkbox"/> SPD - 3 <input type="checkbox"/> SPD - 5 <input type="checkbox"/> SPD - 7 <input type="checkbox"/> SPD - 9 <input type="checkbox"/> SPD - 11 <input type="checkbox"/> SPD - 13  |
|  |                   | <input type="checkbox"/> SPD - 2 <input type="checkbox"/> SPD - 4 <input type="checkbox"/> SPD - 6 <input type="checkbox"/> SPD - 8 <input type="checkbox"/> SPD - 10 <input type="checkbox"/> SPD - 12 <input type="checkbox"/> SPD - 14 |
| POND-6   |                   | <input type="checkbox"/> SPD - 1 <input type="checkbox"/> SPD - 3 <input type="checkbox"/> SPD - 5 <input type="checkbox"/> SPD - 7 <input type="checkbox"/> SPD - 9 <input type="checkbox"/> SPD - 11 <input type="checkbox"/> SPD - 13  |
|  |                   | <input type="checkbox"/> SPD - 2 <input type="checkbox"/> SPD - 4 <input type="checkbox"/> SPD - 6 <input type="checkbox"/> SPD - 8 <input type="checkbox"/> SPD - 10 <input type="checkbox"/> SPD - 12 <input type="checkbox"/> SPD - 14 |
| POND-7   |                   | <input type="checkbox"/> SPD - 1 <input type="checkbox"/> SPD - 3 <input type="checkbox"/> SPD - 5 <input type="checkbox"/> SPD - 7 <input type="checkbox"/> SPD - 9 <input type="checkbox"/> SPD - 11 <input type="checkbox"/> SPD - 13  |
|  |                   | <input type="checkbox"/> SPD - 2 <input type="checkbox"/> SPD - 4 <input type="checkbox"/> SPD - 6 <input type="checkbox"/> SPD - 8 <input type="checkbox"/> SPD - 10 <input type="checkbox"/> SPD - 12 <input type="checkbox"/> SPD - 14 |
| POND-8   |                   | <input type="checkbox"/> SPD - 1 <input type="checkbox"/> SPD - 3 <input type="checkbox"/> SPD - 5 <input type="checkbox"/> SPD - 7 <input type="checkbox"/> SPD - 9 <input type="checkbox"/> SPD - 11 <input type="checkbox"/> SPD - 13  |
|  |                   | <input type="checkbox"/> SPD - 2 <input type="checkbox"/> SPD - 4 <input type="checkbox"/> SPD - 6 <input type="checkbox"/> SPD - 8 <input type="checkbox"/> SPD - 10 <input type="checkbox"/> SPD - 12 <input type="checkbox"/> SPD - 14 |
| POND-9   |                   | <input type="checkbox"/> SPD - 1 <input type="checkbox"/> SPD - 3 <input type="checkbox"/> SPD - 5 <input type="checkbox"/> SPD - 7 <input type="checkbox"/> SPD - 9 <input type="checkbox"/> SPD - 11 <input type="checkbox"/> SPD - 13  |
|  |                   | <input type="checkbox"/> SPD - 2 <input type="checkbox"/> SPD - 4 <input type="checkbox"/> SPD - 6 <input type="checkbox"/> SPD - 8 <input type="checkbox"/> SPD - 10 <input type="checkbox"/> SPD - 12 <input type="checkbox"/> SPD - 14 |
| POND-10  |                   | <input type="checkbox"/> SPD - 1 <input type="checkbox"/> SPD - 3 <input type="checkbox"/> SPD - 5 <input type="checkbox"/> SPD - 7 <input type="checkbox"/> SPD - 9 <input type="checkbox"/> SPD - 11 <input type="checkbox"/> SPD - 13  |
|  |                   | <input type="checkbox"/> SPD - 2 <input type="checkbox"/> SPD - 4 <input type="checkbox"/> SPD - 6 <input type="checkbox"/> SPD - 8 <input type="checkbox"/> SPD - 10 <input type="checkbox"/> SPD - 12 <input type="checkbox"/> SPD - 14 |

| Retired/Closed Pond/Impoundment Systems |  |   |
|---|--|---|
| RET-POND-1                              |  | <input type="checkbox"/> RET SPD - 1 <input type="checkbox"/> RET SPD - 3<br><input type="checkbox"/> RET SPD - 2 <input type="checkbox"/> RET SPD - 4                  |
| RET-POND-2                              |  | <input type="checkbox"/> RET SPD - 1 <input type="checkbox"/> RET SPD - 3<br><input type="checkbox"/> RET SPD - 2 <input type="checkbox"/> RET SPD - 4                  |
| RET-POND-3                              |  | <input type="checkbox"/> RET SPD - 1 <input type="checkbox"/> RET SPD - 3<br><input type="checkbox"/> RET SPD - 2 <input type="checkbox"/> RET SPD - 4                  |
| RET-POND-4                              |  | <input type="checkbox"/> RET SPD - 1 <input type="checkbox"/> RET SPD - 3<br><input type="checkbox"/> RET SPD - 2 <input type="checkbox"/> RET SPD - 4                  |
| RET-POND-5                              |  | <input type="checkbox"/> RET SPD - 1 <input type="checkbox"/> RET SPD - 3<br><input type="checkbox"/> RET SPD - 2 <input type="checkbox"/> RET SPD - 4                  |
| Planned Pond/Impoundment Systems        |  |   |
| POND-A                                  |  | <input type="checkbox"/> SPD - A <input type="checkbox"/> SPD - C <input type="checkbox"/> SPD - E<br><input type="checkbox"/> SPD - B <input type="checkbox"/> SPD - D |
| POND-B                                  |  | <input type="checkbox"/> SPD - A <input type="checkbox"/> SPD - C <input type="checkbox"/> SPD - E<br><input type="checkbox"/> SPD - B <input type="checkbox"/> SPD - D |
| POND-C                                  |  | <input type="checkbox"/> SPD - A <input type="checkbox"/> SPD - C <input type="checkbox"/> SPD - E<br><input type="checkbox"/> SPD - B <input type="checkbox"/> SPD - D |

**CBI?**  
 Yes

**D2-7.** Do you operate OR plan to operate (or begin construction/installation of) by December 31, 2020 any wastewater treatment systems, including those located on non-adjoning property, other than pond/impoundment systems for the treatment of *process wastewaters* from ash handling or FGD operations?

- Yes      (Continue)
- No      [\(Skip to Section 3.1\)](#)

List these wastewater treatment systems in Table D-2. For each wastewater treatment system, EPA assigned a number (e.g., WWT-1, WWT-2) in Table D-2, which will be used throughout the remainder of the survey. In the "Plant Designation" column, provide the plant's name for each wastewater treatment system. As an example, if a plant operates a *chemical precipitation* FGD wastewater treatment system that discharges to an ash pond/impoundment system (as shown in EPA example diagrams EPA\_D-1 and EPA\_D-2 located at the bottom of Part D Section 3.1) the FGD wastewater treatment system should be identified in Table D-2 (e.g., as WWT-1) and the ash pond/impoundment system should have been previously identified in Table D-1 (e.g., as POND-1).

Note that "Approximate Length of Piping from FGD Scrubber System" refers to the length of piping from the *FGD solids separation* overflow storage tank (or *FGD scrubber absorber* if no FGD solids separation) to the beginning of the FGD wastewater treatment system. "Approximate Length of Piping to Subsequent Treatment or Discharge" refers to the length of piping from the end of the FGD wastewater treatment system to either the beginning of the subsequent treatment system or the wastewater discharge point, as appropriate.



**Table D-2. Plant Wastewater Treatment Systems**

| Wastewater Treatment System ID                       | Plant Designation | Treatment System Footprint (ft <sup>2</sup> ) | Year Initially Brought On Line | FGD Wastewater Treatment Systems                           |  |
|--|-------------------|---|--------------------------------|--|--|
|  |                   |   |                                | Approximate Length of Piping from FGD Scrubber System (ft) | Approximate Length of Piping to Subsequent Treatment or Discharge (ft) |
| <b><i>Operating Wastewater Treatment Systems</i></b> |                   |   |                                |  |  |
| WWT-1  |                   |   |                                |  |  |
| WWT-2  |                   |   |                                |  |  |
| WWT-3  |                   |   |                                |  |  |
| WWT-4  |                   |   |                                |  |  |
| WWT-5  |                   |   |                                |  |  |
| WWT-6  |                   |   |                                |  |  |
| <b><i>Planned Wastewater Treatment Systems</i></b>   |                   |   |                                |  |  |
| WWT-A  |                   |   |                                |  |  |
| WWT-B  |                   |   |                                |  |  |
| WWT-C  |                   |   |                                |  |  |

Plant ID:

Plant Name:

Pond/Impoundment System ID or Wastewater Treatment System ID:

**Part: D**

**Section Title:** 3.1. Wastewater Treatment Diagram

**Instructions:** Complete Section 3.1 (Question D3-1) for each *pond/impoundment system* or *wastewater treatment* Table D-2, including planned systems, systems under construction/installation, or planned to be unde December 31, 2020. Enter the pond/impoundment system ID or wastewater treatment system ID in th provided above (use the pond/impoundment system ID or wastewater treatment system ID assigned

Make a copy of Section 3.1 for each pond/impoundment system or wastewater treatment system ide using the "Copy Section 3.1" button below.

Copy Section 3.1

**CBI?**

Yes

**D3-1.** Attach a block diagram that shows the pond/impoundment system or wastewater treatment system o wastewaters that currently enter or are planned to enter the pond/impoundment system or wastewater ultimate destinations of the pond/impoundment system or wastewater treatment system effluent(s). S are provided in the checklist below. The diagram should have a similar level of detail as EPA's exam EPA\_D-2.

**NOTE:** You may use an existing diagram, such as a water balance diagram included in the pla the additional required information on the diagram by hand.

Provide as many diagrams as necessary to convey the information requested in the checklist below. upper right corner; the first block diagram should be numbered D-1, the second D-2, etc. Include the pond/impoundment system ID or wastewater treatment system ID in the upper right hand corner of th

Diagram attached.

**Block Diagram Checklist**

Mark the boxes below to verify that you have completed each checklist item...

- Include the block diagram number, plant name, plant ID, and pond/impoundment system ID or on the diagram.
- Include each pond/impoundment or wastewater treatment unit operation. Show all influent and label all influent and effluent streams from the pond/impoundment system or wastewater treatment units on the "Code Tables" tab provided at the end of this workbook. Note that the "Code Tables" tab includes wastewater treatment units that are operated in series and/or in parallel (e.g., in EPA\_D-1, Ch 1-1 and Chemical Precipitation Reaction Tank 2-1 are in series). Effluent streams may include:
- If applicable, use EPA-assigned numbers from Part A or B (e.g., FGD-1) to label *process operations*. If a process operation does not have an EPA-assigned number (e.g., boiler, air preheater), use the plant-designated name. If sources or destinations are not shown on the diagram (i.e., the stream is entering from a local source or exiting to a local destination), describe the source or destination and add the block diagram number, when appropriate, where it can be seen. Use codes from the code tables on the "Code Tables" tab provided at the end of this workbook.
- Indicate where chemical addition occurs (i.e., into or between which wastewater treatment unit). For wastewater treatment units, indicate and note on the diagram where within or near the pond/impoundment (e.g., within the pond/impoundment near the process wastewater influent point, within the pond/impoundment near the effluent/discharge canal). The chemicals indicated should correspond to the chemicals list on D-9.
- Identify the final, general destination of the *treated* process wastewater and waste streams (e.g., effluent to POTW or surface waters; solid wastes to on- or off-site destinations). Use codes from the "Code Tables" tab provided at the end of this workbook, when applicable.
- Indicate, as appropriate, where treated process wastewater is *reused* or *recycled* within the pond/impoundment (e.g., for fly ash sludge).
- Include the average annual (2009) flow rates for influent and effluent streams from the wastewater treatment diagram (in gpm or gpd). For planned pond/impoundment systems and wastewater treatment units, provide flow rates for the system. Note that these should be the same flow rates that are entered into Table D-1. If the number of days of operation for 2009 is not known, the total annual flow may be divided by 365 on the Comments page. If the process wastewater stream is intermittent, provide amount and frequency (e.g., "100 gpm, 4 hpd, 365 dpy" or "1000 gpm, 4 hpd, 365 dpy"). For sludges, provide amount in tpd.

- Include NPDES permit outfall numbers, if applicable.

If you believe that the diagram should be treated as confidential, stamp it "Confidential" or write "Con  
any diagram is not marked "Confidential", it will be considered nonconfidential under 40 CFR Part 2,

**Review:**

**If any of the statements above were not checked, revise the block diagram(s) and ensure all si**

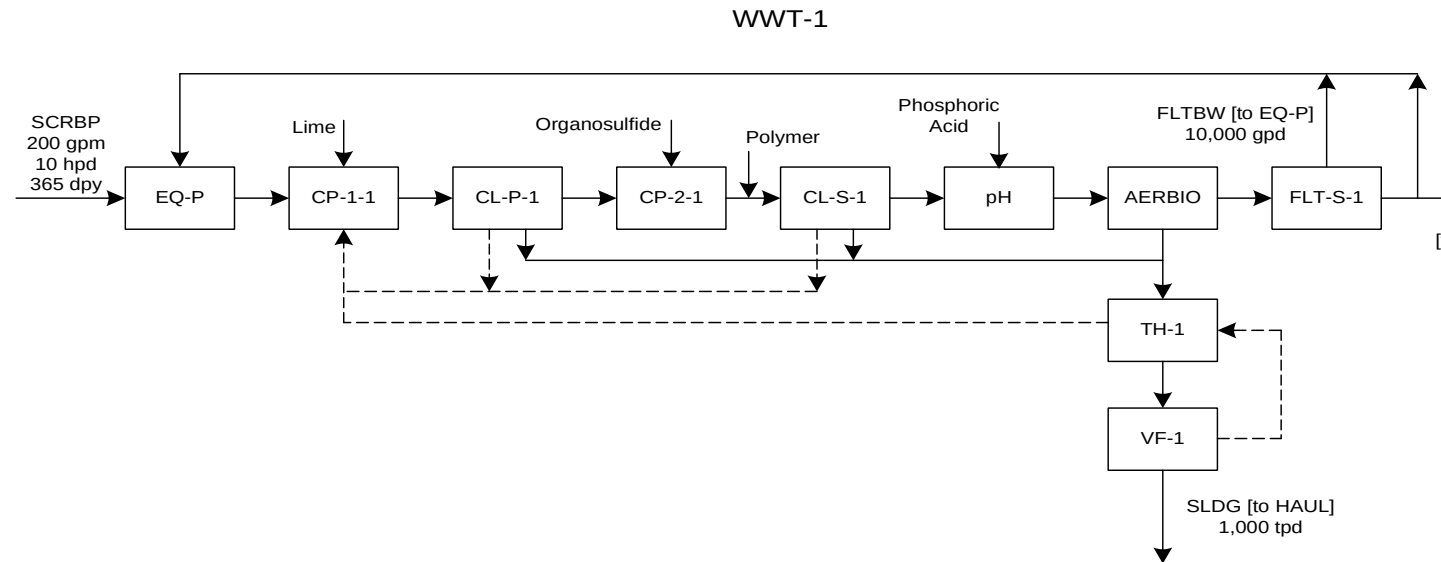

**Example EPA\_D-1. Block Diagram for FGD Wastewater Treatment**

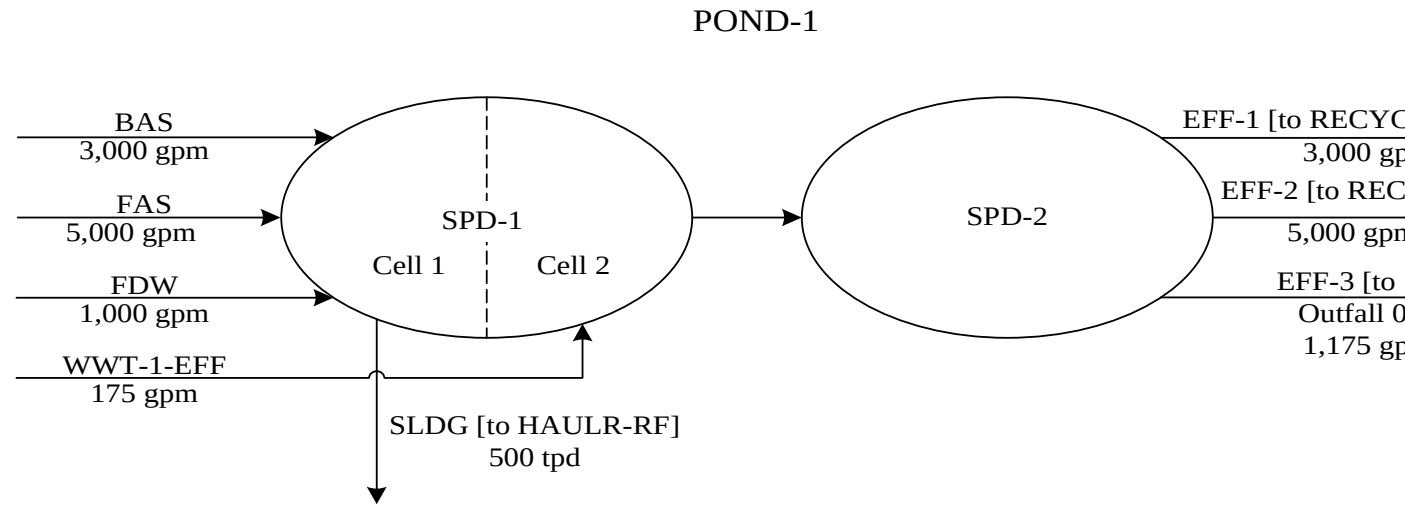

Example EPA\_D-2. Block Diagram for Ash Pond System

**NOTE:** The codes used in these diagrams correspond the code tables on the "Code Tables" workbook.

and Other Wastewater Treatment Operations

Insert Plant ID

Insert Plant Name

Insert System ID

system identified in Table D-1 and  
or construction/installation by  
the yellow highlighted space  
in Table D-1 and Table D-2).

ntified in Table D-1 and Table D-2

operations, the process  
or treatment system, and the  
specific instructions for the diagram  
ple diagrams, EPA\_D-1 and

**nt's NPDES Form 2C, and mark**

Number each block diagram in the  
plant name, plant ID, and  
re diagram.

and Other Wastewater Treatment Operations

Wastewater treatment system ID

Effluent streams from the units  
Wastewater treatment system using the code  
"Codes" tab provides codes for  
Chemical Precipitation Reaction Tank  
Process wastewater and sludges.

Operations. If a process operation does  
not exist for the process operation. When  
operation is not shown on the diagram,  
reference the stream's previous location  
in this workbook.

ts). For pond/impoundment  
Impoundment the chemical is added  
to the pond/impoundment near the effluent, in  
accordance with Tables Table D-5 and Table

e.g., treated process wastewater  
Refer to code tables on the "Code

Water (e.g., reuse of settling

Water treatment system on the  
systems, provide the design flow  
rate as shown in Question D2-2. If the actual  
flow is not known, assume a flow rate of  
15 days and a comment added to  
the spreadsheet; for example "100 gal,

idential" or "CBI" across the top. If Subpart B.

tatements have been checked.

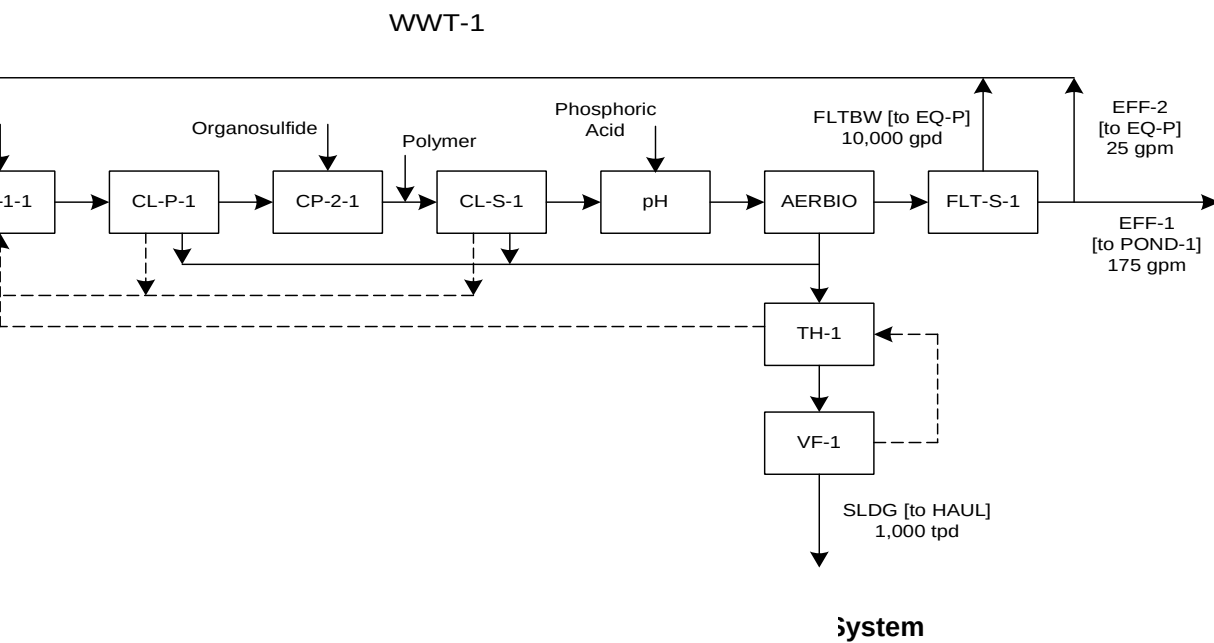



POND-1

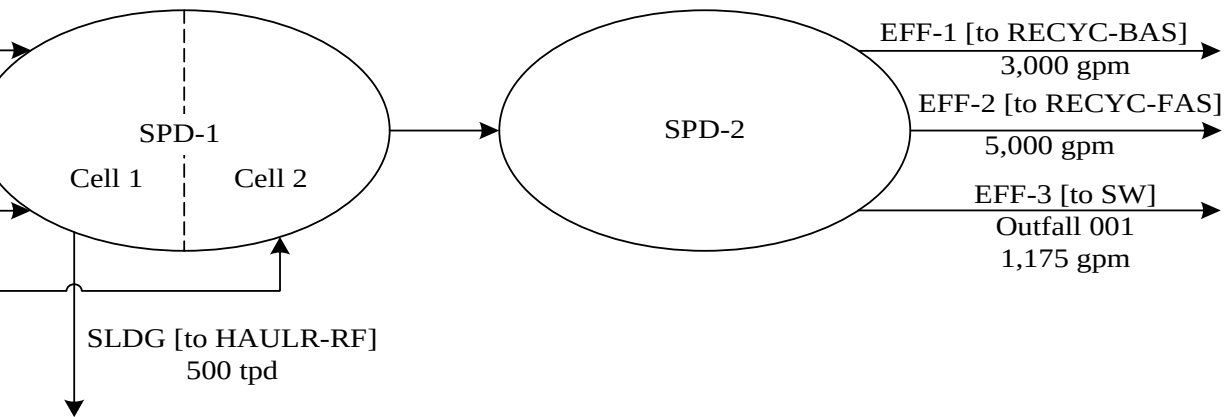

' tab provided at the end of this

Plant ID: Insert Plant ID  
 Plant Name: Insert Plant Name

Pond/Impoundment System ID or Wastewater Treatment System ID: Insert System ID

**Part: D**

**Section Title: 3.2. Wastewater Treatment Wastewater Flows**

**Instructions:** Complete Section 3.2 (Question D3-2 and D3-3) for each *pond/impoundment system* or *wastewater treatment system* identified in Table D-1 and Table D-2, including planned systems, systems under construction/installation, or planned to be under construction/installation by December 31, 2020. Enter the pond/impoundment system ID or wastewater treatment system ID in the yellow highlighted space provided above (use the pond/impoundment system ID or wastewater treatment system ID assigned in Table D-1 and Table D-2).

Make a copy of Section 3.2 for each pond/impoundment system or wastewater treatment system identified in Table D-1 and Table D-2 using the "Copy Section 3.2" button below.

Copy Section 3.2

**CBI?**

Ye

**D3-2.** Complete a row in Table D-3 for each *process wastewater* stream or *treated* wastewater stream that enters this pond/impoundment system or wastewater treatment system. For planned pond/impoundment systems and wastewater treatment systems, provide the design flow rates for the system. Use the process and treated wastewater terms provided in the drop down menus. Note that these terms originated from code tables on the "Code Tables" tab provided at the end of this workbook.

Note: The examples in Tables D-3 and D-4 are derived from the EPA examples diagrams, EPA\_D-1 and EPA\_D-2, provided at the bottom of Part D Section 3.1.

**Table D-3. Pond/Impoundment System or Wastewater Treatment System Influent Flows in 2009**

| Process or Treated Wastewater  | Average Annual (2009) Wastewater Flow Rate |                          |                          | Wastewater Treatment Unit ID |
|--------------------------------|--|--------------------------|--------------------------|------------------------------|
| <b>Example (from EPA_D-1):</b> |  |                          |                          |                              |
| <input type="text"/>           | 200 gpm                                    | 10 hpd                   | 365 dpy                  | <input type="text"/>         |
| Other: <input type="text"/>    | OR   | gpd                      | dpy                      | Other: <input type="text"/>  |
| <b>Example (from EPA_D-2):</b> |  |                          |                          |                              |
| <input type="text"/>           | 175 gpm                                    | 24 hpd                   | 365 dpy                  | <input type="text"/>         |
| Other: <input type="text"/>    | OR   | gpd                      | dpy                      | Other: <input type="text"/>  |
| <input type="text"/>           | <input type="text"/> gpm                   | <input type="text"/> hpd | <input type="text"/> dpy | <input type="text"/>         |
| Other: <input type="text"/>    | OR   | <input type="text"/> gpd | <input type="text"/> dpy | Other: <input type="text"/>  |
| <input type="text"/>           | <input type="text"/> gpm                   | <input type="text"/> hpd | <input type="text"/> dpy | <input type="text"/>         |
| Other: <input type="text"/>    | OR   | <input type="text"/> gpd | <input type="text"/> dpy | Other: <input type="text"/>  |
| <input type="text"/>           | <input type="text"/> gpm                   | <input type="text"/> hpd | <input type="text"/> dpy | <input type="text"/>         |
| Other: <input type="text"/>    | OR   | <input type="text"/> gpd | <input type="text"/> dpy | Other: <input type="text"/>  |
| <input type="text"/>           | <input type="text"/> gpm                   | <input type="text"/> hpd | <input type="text"/> dpy | <input type="text"/>         |
| Other: <input type="text"/>    | OR   | <input type="text"/> gpd | <input type="text"/> dpy | Other: <input type="text"/>  |
| <input type="text"/>           | <input type="text"/> gpm                   | <input type="text"/> hpd | <input type="text"/> dpy | <input type="text"/>         |
| Other: <input type="text"/>    | OR   | <input type="text"/> gpd | <input type="text"/> dpy | Other: <input type="text"/>  |
| <input type="text"/>           | <input type="text"/> gpm                   | <input type="text"/> hpd | <input type="text"/> dpy | <input type="text"/>         |
| Other: <input type="text"/>    | OR   | <input type="text"/> gpd | <input type="text"/> dpy | Other: <input type="text"/>  |

|        |    |     |     |     |        |
|--------|----|-----|-----|-----|--------|
|        |    | gpm | hpd | dpy |        |
| Other: | OR |     | gpd | dpy | Other: |
|        |    | gpm | hpd | dpy |        |
| Other: | OR |     | gpd | dpy | Other: |
|        |    | gpm | hpd | dpy |        |
| Other: | OR |     | gpd | dpy | Other: |
|        |    | gpm | hpd | dpy |        |
| Other: | OR |     | gpd | dpy | Other: |
|        |    | gpm | hpd | dpy |        |
| Other: | OR |     | gpd | dpy | Other: |
|        |    | gpm | hpd | dpy |        |
| Other: | OR |     | gpd | dpy | Other: |
|        |    | gpm | hpd | dpy |        |
| Other: | OR |     | gpd | dpy | Other: |
|        |    | gpm | hpd | dpy |        |
| Other: | OR |     | gpd | dpy | Other: |
|        |    | gpm | hpd | dpy |        |
| Other: | OR |     | gpd | dpy | Other: |
|        |    | gpm | hpd | dpy |        |
| Other: | OR |     | gpd | dpy | Other: |
|        |    | gpm | hpd | dpy |        |
| Other: | OR |     | gpd | dpy | Other: |
|        |    | gpm | hpd | dpy |        |
| Other: | OR |     | gpd | dpy | Other: |
|        |    | gpm | hpd | dpy |        |
| Other: | OR |     | gpd | dpy | Other: |
|        |    | gpm | hpd | dpy |        |
| Other: | OR |     | gpd | dpy | Other: |
|        |    | gpm | hpd | dpy |        |
| Other: | OR |     | gpd | dpy | Other: |
|        |    | gpm | hpd | dpy |        |
| Other: | OR |     | gpd | dpy | Other: |
|        |    | gpm | hpd | dpy |        |
| Other: | OR |     | gpd | dpy | Other: |
|        |    | gpm | hpd | dpy |        |
| Other: | OR |     | gpd | dpy | Other: |
|        |    | gpm | hpd | dpy |        |
| Other: | OR |     | gpd | dpy | Other: |

**CBI?**  
 Yes

**D3-3.** Complete a row in Table D-4 for each treated wastewater stream or *sludge* stream that exits this pond/impoundment system or wastewater treatment system (i.e., streams that are *discharged, recycled, or* disposed). For planned pond/impoundment systems and wastewater treatment systems, provide the design flow rates for the system. Use the treated wastewater, wastewater treatment unit, and destination terms provided in the drop down menus. Note that these terms originated from code tables on the "Code Tables" tab provided at the end of this workbook.

\*Provide the NPDES permit outfall number of the effluent in the last column of the table, if applicable.

**Table D-4. Pond/Impoundment System or Wastewater Treatment System Effluent Flows in 2009**

| Treated Wastewater             | Average Annual (2009) Wastewater Flow Rate |            |         | Solids and Sludge   |  | Final Destination            |             |                              |     |
|--------------------------------|--|------------|---------|---------------------|--|------------------------------|-------------|------------------------------|-----|
|                                |  |            |         | Amount (tpd or gpm) | % Moisture   | Wastewater Treatment Unit ID | Destination | NPDES Permit Outfall Number* |     |
| <b>Example (from EPA_D-1):</b> |  |            |         |                     | <input type="radio"/> tpd<br><input type="radio"/> gpm |                              |             |                              |     |
|                                | 175 gpm                                    | 24 hpd     | 365 dpy | NA                  | NA   |                              |             |                              | NA  |
| Other:                         | OR   | NA         | NA      | NA                  |  | Other:                       | Other:      |                              |     |
| <b>Example (from EPA_D-1):</b> |  |            |         |                     | <input type="radio"/> tpd<br><input type="radio"/> gp  |                              |             |                              |     |
|                                | NA   | NA         | NA      | NA                  | NA   |                              |             |                              | NA  |
| Other:                         | OR   | 10,000 gpd | 365 dpy |                     |  | Other:                       | Other:      |                              |     |
| <b>Example (from EPA_D-2):</b> |  |            |         |                     | <input type="radio"/> tpc<br><input type="radio"/> gpd |                              |             |                              |     |
|                                | NA   | NA         | NA      | 500                 | 30   |                              |             |                              | NA  |
| Other:                         | OR   | NA         | NA      |                     |  | Other:                       | Other:      |                              |     |
| <b>Example (from EPA_D-2):</b> |  |            |         |                     | <input type="radio"/> tpc<br><input type="radio"/> gpd |                              |             |                              |     |
|                                | 5,000 gpm                                  | 24 hpd     | 365 dpy | NA                  | NA   |                              |             |                              | NA  |
| Other:                         | OR   | NA         | NA      |                     |  | Other:                       | Other:      |                              |     |
| <b>Example (from EPA_D-2):</b> |  |            |         |                     | <input type="radio"/> tpc<br><input type="radio"/> gpd |                              |             |                              |     |
|                                | 1,175 gpm                                  | 24 hpd     | 365 dpy | NA                  | NA   |                              |             |                              | 001 |
| Other:                         | OR   |            |         |                     |  | Other:                       | Other:      |                              |     |
|                                |  |            |         |                     | <input type="radio"/> tpd<br><input type="radio"/> gp  |                              |             |                              |     |
| Other:                         | OR   |            |         |                     |  | Other:                       | Other:      |                              |     |
|                                |  |            |         |                     | <input type="radio"/> tpc<br><input type="radio"/> gpd |                              |             |                              |     |
| Other:                         | OR   |            |         |                     |  | Other:                       | Other:      |                              |     |
|                                |  |            |         |                     | <input type="radio"/> tpd<br><input type="radio"/> gpd |                              |             |                              |     |
| Other:                         | OR   |            |         |                     |  | Other:                       | Other:      |                              |     |
|                                |  |            |         |                     | <input type="radio"/> tpc<br><input type="radio"/> gpd |                              |             |                              |     |
| Other:                         | OR   |            |         |                     |  | Other:                       | Other:      |                              |     |
|                                |  |            |         |                     | <input type="radio"/> tpc<br><input type="radio"/> gpd |                              |             |                              |     |
| Other:                         | OR   |            |         |                     |  | Other:                       | Other:      |                              |     |
|                                |  |            |         |                     | <input type="radio"/> tpc<br><input type="radio"/> gpd |                              |             |                              |     |
| Other:                         | OR   |            |         |                     |  | Other:                       | Other:      |                              |     |

|        |    |     |     |     |  |                           |        |        |  |
|--------|----|-----|-----|-----|--|---------------------------|--------|--------|--|
|        |    | gpm | hpd | dpy |  | <input type="radio"/> tnc |        |        |  |
| Other: | OR |     | gpd | dpy |  | <input type="radio"/> gpr | Other: | Other: |  |
|        |    | gpm | hpd | dpy |  | <input type="radio"/> tnc |        |        |  |
| Other: | OR |     | gpd | dpy |  | <input type="radio"/> gpr | Other: | Other: |  |
|        |    | gpm | hpd | dpy |  | <input type="radio"/> tnc |        |        |  |
| Other: | OR |     | gpd | dpy |  | <input type="radio"/> gpr | Other: | Other: |  |
|        |    | gpm | hpd | dpy |  | <input type="radio"/> tnc |        |        |  |
| Other: | OR |     | gpd | dpy |  | <input type="radio"/> gpr | Other: | Other: |  |
|        |    | gpm | hpd | dpy |  | <input type="radio"/> tnc |        |        |  |
| Other: | OR |     | gpd | dpy |  | <input type="radio"/> gpr | Other: | Other: |  |
|        |    | gpm | hpd | dpy |  | <input type="radio"/> tnc |        |        |  |
| Other: | OR |     | gpd | dpy |  | <input type="radio"/> gpr | Other: | Other: |  |
|        |    | gpm | hpd | dpy |  | <input type="radio"/> tnc |        |        |  |
| Other: | OR |     | gpd | dpy |  | <input type="radio"/> gpr | Other: | Other: |  |
|        |    | gpm | hpd | dpy |  | <input type="radio"/> tnc |        |        |  |
| Other: | OR |     | gpd | dpy |  | <input type="radio"/> gpr | Other: | Other: |  |
|        |    | gpm | hpd | dpy |  | <input type="radio"/> tnc |        |        |  |
| Other: | OR |     | gpd | dpy |  | <input type="radio"/> gpr | Other: | Other: |  |
|        |    | gpm | hpd | dpy |  | <input type="radio"/> tnc |        |        |  |
| Other: | OR |     | gpd | dpy |  | <input type="radio"/> gpr | Other: | Other: |  |
|        |    | gpm | hpd | dpy |  | <input type="radio"/> tnc |        |        |  |
| Other: | OR |     | gpd | dpy |  | <input type="radio"/> gpr | Other: | Other: |  |
|        |    | gpm | hpd | dpy |  | <input type="radio"/> tnc |        |        |  |
| Other: | OR |     | gpd | dpy |  | <input type="radio"/> gpr | Other: | Other: |  |
|        |    | gpm | hpd | dpy |  | <input type="radio"/> tnc |        |        |  |
| Other: | OR |     | gpd | dpy |  | <input type="radio"/> gpr | Other: | Other: |  |
|        |    | gpm | hpd | dpy |  | <input type="radio"/> tnc |        |        |  |
| Other: | OR |     | gpd | dpy |  | <input type="radio"/> gpr | Other: | Other: |  |
|        |    | gpm | hpd | dpy |  | <input type="radio"/> tnc |        |        |  |
| Other: | OR |     | gpd | dpy |  | <input type="radio"/> gpr | Other: | Other: |  |
|        |    | gpm | hpd | dpy |  | <input type="radio"/> tnc |        |        |  |
| Other: | OR |     | gpd | dpy |  | <input type="radio"/> gpr | Other: | Other: |  |

Plant ID: Insert Plant ID

Plant Name: Insert Plant Name

Pond/Impoundment Unit ID: Insert Unit ID

**Part: D**

**Section Title:** 4.1. Active/Inactive/Open and Planned Pond/Impoundment Unit Information

**Instructions:** Complete Section 4.1 (Questions D4-1 through D4-12) for each active/inactive/open pond/impoundment unit used OR planned to be used (or constructed/installed), including those located on non-adjointing property, by December 31, 2020 for the storage, treatment, and/or disposal of process wastewater, residues, or by-products (or sludges or water streams containing the residues or by-products) from the combustion of coal, petroleum coke, or oil, including but not limited to fly ash, bottom ash, boiler slag, or flue gas emission control residues. Use the pond/impoundment unit IDs assigned in Table A-4.

Make a copy of Section 4.1 for each active/inactive/open and planned pond/impoundment units used (or planned to be used) for the storage, treatment, and/or disposal of process wastewater, residues, or by-products (or sludges or water streams containing the residues or by-products) from the combustion of coal, petroleum coke, or oil, including but not limited to fly ash, bottom ash, boiler slag, or flue gas emission control residues using the "Copy Section 4.1" button below.

NOTE: If a pond/impoundment unit is part of a broader wastewater treatment system containing non-pond wastewater treatment units (e.g., a pond/impoundment unit in a biological wastewater treatment system), complete questions in this section for the pond/impoundment unit.

**CBI?**  
 **Ye**

**D4-1.** Do you use OR plan to use (or begin construction/installation of) by December 31, 2020, any active/inactive/open ponds/impoundments, including those located on non-adjointing property, for the storage, treatment, and/or disposal of process wastewater, residues, or by-products (or sludges or water streams containing the residues or by-products) from the combustion of coal, petroleum coke, or oil, including but not limited to fly ash, bottom ash, boiler slag, or flue gas emission control residues?

- Yes** (Continue)
- No** ([Skip to Section 4.2](#))

**Copy Section 4.1**

**CBI?**  
 **Ye**

**D4-2.** Provide the residence time of the process wastewater in the pond/impoundment unit, the life of the pond/impoundment unit (based on the current estimation), and the number of cells in the pond/impoundment unit.

Residence time, hours (as currently operated)

Life of pond/impoundment unit, years (based on current estimation)

Number of cells in pond/impoundment unit

**CBI?**  
 **Ye**

**D4-3.** Complete Table D-5. Provide the pond/impoundment unit's volume, surface area, bottom and top elevation, freeboard height, maximum height of berms and dams above the surrounding grade, and the total quantity of solids placed in the pond/impoundment when it was originally built or planned/designed, at its current status, and at its expected end of life. Additionally, provide the expected year of closure/retirement in the "Expected End of Life" column. Volume should reflect the free water volume, including the stored solids. For planned pond/impoundment units, enter "NA" in all fields in the "Current" column. Figure D-1 presents an illustration of pond/impoundment dimensions.

Note: Respondents are not required to take new measurements to provide this data; however, best available information should be used to answer Table D-5.

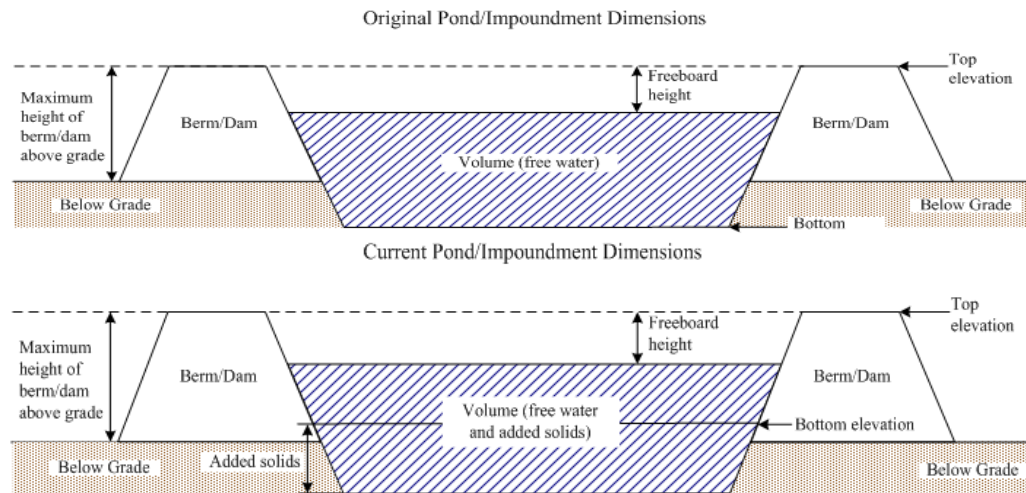

Figure D-1. Pond/Impoundment Dimensions

Table D-5. Active/Inactive/Open and Planned Pond/Impoundment Information

|   | Originally Built or Planned/Designed | Current | Expected End of Life |
|---|--------------------------------------|---------|----------------------|
| Volume, ft <sup>3</sup>                           |                                      |         |                      |
| Surface area, ft <sup>2</sup>                     |                                      |         |                      |
| Bottom elevation, ft                              |                                      |         |                      |
| Top elevation, ft                                 |                                      |         |                      |
| Freeboard height, ft                              |                                      |         |                      |
| Maximum height of berms/dams above grade, ft      |                                      |         |                      |
| Total solids placed in the pond/impoundment, tons |                                      |         |                      |
| Expected year of closure/retirement               |                                      |         |                      |

CBI?  
 Yes

D4-4. Does the pond/impoundment unit have a liner?

- Yes (Complete Table D-6)
- No (Skip to Question D4-5)
- NA (Pond/Impoundment is planned to be constructed. Information is currently unavailable. Skip to Question D4-10).

Table D-6. Pond/Impoundment Unit Liner

| Liner Layer Number (number from inner to outer layer) | Type of Liner  | Thickness of Liner Layer (cm) | Permeability of Liner Layer (cm/sec) |
|---|--|-------------------------------|--------------------------------------|
|   | <input type="radio"/> Compacted clay<br><input type="radio"/> Geosynthetic c<br><input type="radio"/> High density polye<br><input type="radio"/> Other (provide |                               |                                      |
|   |  |                               |                                      |
|   | <input type="radio"/> Compacted clay<br><input type="radio"/> Geosynthetic c<br><input type="radio"/> High density polye<br><input type="radio"/> Other (provide |                               |                                      |
|   |  |                               |                                      |
|   | <input type="radio"/> Compacted clay<br><input type="radio"/> Geosynthetic c<br><input type="radio"/> High density polye<br><input type="radio"/> Other (provide |                               |                                      |
|   |  |                               |                                      |
|   | <input type="radio"/> Compacted clay<br><input type="radio"/> Geosynthetic c<br><input type="radio"/> High density polye<br><input type="radio"/> Other (provide |                               |                                      |
|   |  |                               |                                      |

CBI?  
 Yes

D4-5. Has the pond/impoundment unit ever been dredged?

- Yes (Provide following
  - Year of last dredging
  - Frequency of dredging that year, dpy
  - Amount of material removed that year, tons
  - Number of times dredged in the last five years
  - Number of days dredged in the last five years
  - Amount of material removed in the last five years, tons
- No (Skip to Question D4-7)
- NA (Pond/Impoundment is planned to be constructed. Skip to Question D4-10)



CBI?  Yes

D4-6. Indicate where the dredged solids are transferred or are planned to be transferred.

- Dredged solids used in embankment
- Dredged solids transferred
- Dredged solids marketed/sold
- Other (Explain )

CBI?  Yes

D4-7. Has the pond/impoundment unit been expanded since the date it was built?

- Yes (Continue)
- No (Skip to Question D4-10)
- NA (Pond/impoundment is planned to be constructed. Skip to Question D4-10)

CBI?  Yes

D4-8. Identify the type of expansion.

- Lateral expansion
- Vertical expansion
- Both lateral and vertical expansion

CBI?  Yes

D4-9. Describe the expansion(s) to the pond/impoundment unit, including the starting and ending dimensions and the total capital and O&M costs associated with the expansion(s).

**Note: Total O&M costs should include labor, materials, energy, hazardous and nonhazardous waste disposal, and any other costs available. Total capital costs should include purchased equipment, installation, buildings, site preparation, land, engineering costs, construction expenses, and any other costs available.**

CBI?  Yes

D4-10. Indicate the *pollutants* targeted for removal by this pond/impoundment unit using techniques other than solely settling (e.g., adding chemicals to remove certain metals). [Check all boxes that apply.]

- Metals (specify )
- TSS
- Nitrogen compounds (ammonia, nitrate, nitrite)
- Organic
- Chlorine or other oxidizing agents
- Oil and grease
- Other:
- NA (Skip to Question D4-12)

CBI?  
 Yes

D4-11. Of the pollutants listed in D4-10, which effluent limitation(s) drives/will drive the operation of this pond/impoundment unit? Provide the pollutant and the limitation (mg/L or ug/L).

Pollutant:

Limitation:

Pollutant:

Limitation:

Pollutant:

Limitation:

CBI?  
 Yes

D4-12. Did the plant add chemicals to this pond/impoundment unit in 2009?

- Yes: (Complete Table D-7)
- No: ([Skip to Section 4.2](#))
- No: (Pond/impoundment is planned to be constructed. Provide information in Table D-7 to the extent possible based on plans.)

Note that "Chemical Type" refers to the generic name of the chemical added to the pond/impoundment (e.g., lime, sodium hydroxide, alum, polymer). "Average Dose Concentration" refers to the average concentration of the chemical within the pond/impoundment unit just after it is added to the unit. In the "Location of Chemical Addition" column, indicate where within or near the pond/impoundment the chemical is added (e.g., within the pond/impoundment near the process wastewater influent point, within the pond/impoundment near the effluent, in the effluent/discharge canal). If chemical addition is known only on a yearly basis, divide the yearly value by the approximate number of days the plant added chemicals (which should be the same estimate for the "Frequency of Addition" column).

Table D-7. Chemicals Used in Pond/Impoundment Unit Operations

| Chemical Type | Trade Name | Manufacturer | Purpose | Location of Chemical Addition | Average Dose Concentration (g/L) | Average Addition Rate (gpd or lb/day)                   |  | Frequency of Addition (dpy) |
|---------------|------------|--------------|---------|-------------------------------|----------------------------------|---|--|-----------------------------|
|               |            |              |         |                               |                                  | <input type="radio"/> gpd<br><input type="radio"/> lb/d | <input type="radio"/> Sol<br><input type="radio"/> Liq |                             |
|               |            |              |         |                               |                                  | <input type="radio"/> qpd<br><input type="radio"/> lb/c | <input type="radio"/> Sol<br><input type="radio"/> Liq |                             |
|               |            |              |         |                               |                                  | <input type="radio"/> gpd<br><input type="radio"/> lb/c | <input type="radio"/> Sol<br><input type="radio"/> Liq |                             |
|               |            |              |         |                               |                                  | <input type="radio"/> gpd<br><input type="radio"/> lb/d | <input type="radio"/> Sol<br><input type="radio"/> Liq |                             |
|               |            |              |         |                               |                                  | <input type="radio"/> qpd<br><input type="radio"/> lb/d | <input type="radio"/> Sol<br><input type="radio"/> Liq |                             |

Plant ID: Insert Plant ID

Plant Name: Insert Plant Name

Pond/Impoundment Unit ID: Insert Unit ID

**Part: D**

**Section Title:** 4.2. Closed Pond/Impoundment Unit Information

**Instructions:** Complete Section 4.2 (Questions D4-13 through D4-24) for all *pond/impoundment* units closed on or after January 1, 2000, including those located on non-adjointing property, that were used for the storage, treatment, and/or disposal of *process wastewater, residues, or by-products* (or *sludges* or water streams containing the residues or by-products) from the combustion of coal, petroleum coke, or oil, including but not limited to fly ash, bottom ash, boiler slag, or flue gas emission control residues (use pond/impoundment unit IDs assigned in Table A-4).

Make a copy of Section 4.2 for each closed pond/impoundment unit, including those located on non-adjointing property, that was used for the storage, treatment, and/or disposal of process wastewater, residues, or by-products (or sludges or water streams containing the residues or by-products) from the combustion of coal, petroleum coke, or oil, including but not limited to *fly ash, bottom ash, boiler slag, or flue gas emission control residues* using the "Copy Section 4.2" button below.

**NOTE: If a pond/impoundment was part of a broader wastewater treatment system containing *non-pond wastewater treatment units* (e.g., a pond/impoundment unit in a biological wastewater treatment system), complete questions in this section for the pond/impoundment unit.**

**CBI?**

Yes

**D4-13.** Are there any ponds/impoundments closed on or after January 1, 2000, including those located on non-adjointing property, that were used for the storage, treatment, and/or disposal of residues or by-products (or sludges or water streams containing the residues or by-products) from the combustion of coal, petroleum coke, or oil, including but not limited to fly ash, bottom ash, boiler slag, or flue gas emission control residues?

Yes (Continue)

No [\(Skip to Section 5.1\)](#)

Copy Section 4.2

**CBI?**  
 Yes

**D4-14.** Provide the date the pond/impoundment unit was closed, the actual life of the pond/impoundment unit, and the number of cells in the pond/impoundment unit.

Date Closed (day/month/year)

Life of pond/impoundment unit (years, actual)

Number of cells in pond/impoundment unit

**CBI?**  
 Yes

**D4-15.** Complete Table D-8. Provide the pond/impoundment unit's volume, surface area, bottom and top elevation, freeboard height, maximum height of berms and dams above the surrounding grade, and the total quantity of solids placed in the pond/impoundment when it was originally built and at its end of life. Volume should reflect original and final (accounting for any expansions) free water volume, including the stored solids. Please refer back to Figure D-1 for an illustration of pond/impoundment dimensions.

**Table D-8. Closed Pond/Impoundment Information**

|   | Originally Built | End of Life |
|---|------------------|-------------|
| Volume, ft <sup>3</sup>                           |                  |             |
| Surface area, ft <sup>2</sup>                     |                  |             |
| Bottom elevation, ft                              |                  |             |
| Top elevation, ft                                 |                  |             |
| Freeboard height, ft                              |                  |             |
| Maximum height of berms/dams above grade, ft      |                  |             |
| Total solids placed in the pond/impoundment, tons |                  |             |

**CBI?**  
 Yes

**D4-16.** Does the pond/impoundment unit have a *liner*?

- Yes (Complete Table D-9)
- No (Skip to Question D4-17)

**Table D-9. Pond/Impoundment Unit Liner**

| Liner Layer Number<br>(number from inner to<br>outer layer) | Type of Liner   | Thickness of Liner<br>Layer (cm) | Permeability of Liner Layer<br>(cm/sec) |
|---|---|----------------------------------|---|
|   | <input type="radio"/> Compacted clay<br><input type="radio"/> Geosynthetic clay<br><input type="radio"/> High density polyethylene (HDPE)<br><input type="radio"/> Other (provide below:) |                                  |   |
|   |   |                                  |   |
|   |   |                                  |   |
|   | <input type="radio"/> Compacted clay<br><input type="radio"/> Geosynthetic clay<br><input type="radio"/> High density polyethylene (HDPE)<br><input type="radio"/> Other (provide below:) |                                  |   |
|   |   |                                  |   |
|   |   |                                  |   |
|   | <input type="radio"/> Compacted clay<br><input type="radio"/> Geosynthetic clay<br><input type="radio"/> High density polyethylene (HDPE)<br><input type="radio"/> Other (provide below:) |                                  |   |
|   |   |                                  |   |
|   |   |                                  |   |
|   | <input type="radio"/> Compacted clay<br><input type="radio"/> Geosynthetic clay<br><input type="radio"/> High density polyethylene (HDPE)<br><input type="radio"/> Other (provide below:) |                                  |   |
|   |   |                                  |   |
|   |   |                                  |   |

|  |  |  |  |
|--|--|--|--|
|  | <input type="radio"/> Compacted clay<br><input type="radio"/> Geosynthetic clay                        |  |  |
|  | <input type="radio"/> High density polyethylene (HDPE)<br><input type="radio"/> Other (provide below:) |  |  |
|  |  |  |  |

**CBI?**  
 Yes

**D4-17.** Does the pond/impoundment unit have a cap/cover?

- Yes (Complete Table D-10)
- No (Skip to Question D4-18)

**Table D-10. Pond/Impoundment Unit Cap/Cover**

| Cap/Cover Layer Number<br>(number from inner to<br>outer layer) | Type of Cap/Cover Layer   | Thickness of<br>Cap/Cover Layer (cm) | Permeability of Cap/Cover<br>Layer (cm/sec) |
|---|---|--------------------------------------|---|
|   | <input type="radio"/> Compacted clay<br><input type="radio"/> Geosynthetic clay   |                                      |   |
|   | <input type="radio"/> Vegetative cover<br><input type="radio"/> High density polyethylene (HDPE);<br><input type="radio"/> Other (provide below:) |                                      |   |
|   |   |                                      |   |
|   | <input type="radio"/> Compacted clay<br><input type="radio"/> Geosynthetic clay   |                                      |   |
|   | <input type="radio"/> Vegetative cover<br><input type="radio"/> High density polyethylene (HDPE);<br><input type="radio"/> Other (provide below:) |                                      |   |
|   |   |                                      |   |

|  |  |  |  |
|--|--|--|--|
|  | <input type="radio"/> Compacted clay<br><input type="radio"/> Geosynthetic clay<br><input type="radio"/> Vegetative cover<br><input type="radio"/> High density polyethylene (HDPE)<br><input type="radio"/> Other (provide below:)<br>_____ |  |  |
|  |  |  |  |
|  | <input type="radio"/> Compacted clay<br><input type="radio"/> Geosynthetic clay<br><input type="radio"/> Vegetative cover<br><input type="radio"/> High density polyethylene (HDPE)<br><input type="radio"/> Other (provide below:)<br>_____ |  |  |
|  |  |  |  |
|  | <input type="radio"/> Compacted clay<br><input type="radio"/> Geosynthetic clay<br><input type="radio"/> Vegetative cover<br><input type="radio"/> High density polyethylene (HDPE)<br><input type="radio"/> Other (provide below:)<br>_____ |  |  |
|  |  |  |  |
|  | <input type="radio"/> Compacted clay<br><input type="radio"/> Geosynthetic clay<br><input type="radio"/> High density polyethylene (HDPE)<br><input type="radio"/> Vegetative cover<br><input type="radio"/> Other (provide below:)<br>_____ |  |  |
|  |  |  |  |

**CBI?**

Yes

**D4-18.** Was the pond/impoundment unit expanded during its life?

- Yes (Continue)
- No (Skip to Question 4-21)

**CBI?**  
 Yes

**D4-19.** Identify the type of expansion.

- Lateral expansion
- Vertical expansion
- Both lateral and vertical expansion

**CBI?**  
 Yes

**D4-20.** Describe the expansion(s) to the pond/impoundment unit, including the starting and ending dimensions and the total capital and O&M costs associated with the expansion(s).

**Note: Total O&M costs should include labor, materials, energy, hazardous and nonhazardous waste disposal, and any other costs available. Total capital costs should include purchased equipment, installation, buildings, site preparation, land, engineering costs, construction expenses, and any other costs available.**

**CBI?**  
 Yes

**D4-21.** Did the plant have a closure plan for this pond/impoundment unit?

- Yes (Provide a copy of the closure plan)
- No (Continue)

**CBI?**  
 Yes

**D4-22.** Describe the closure process, the required steps, and the costs associated with the closure.

**Note: If you attached a closure plan for the previous question that includes information on the required steps and associated costs of the closure, do not answer this question and indicate that the information is provided in the attached closure plan.**

Information provided in attached closure plan



**CRI?**

Yes

**D4-23.** Has the plant built any structures on top of the closed pond/impoundment?

Yes (Continue)

No (Skip to Question D4-24)

Provide a description of the structure(s) and any challenges that the plant faced building on top of the pond/impoundment.

**CBI?**

Yes

**D4-24.** Is the plant performing or does it intend to perform long-term groundwater, soil, or overflow monitoring of this closed pond/impoundment unit?

Yes. Describe the monitorir

No

Plant ID: Insert Plant ID  
 Plant Name: Insert Plant Name  
 Wastewater Treatment System ID: Insert System ID

**Part: D**  
**Section Title:** 5.1. Wastewater Treatment Unit Information - System Level

**Instructions:** Complete Section 5.1 (Questions D5-1 through D5-12) for each *wastewater treatment system* identified in Table D-2, including planned (under construction/installation, or planned to be under construction/installation by December 31, 2020) wastewater treatment systems. Enter the wastewater treatment system ID in the space provided above (use wastewater treatment system ID assigned in Table D-2).

Make a copy of Section 5.1 for each wastewater treatment system identified in Table D-2 using the "Copy Section 5.1" button below.

**NOTE: If the wastewater treatment system includes a pond/impoundment unit, include the pond/impoundment unit in Table D-11.**

**CRI?**  
 Yes

**D5-1.** Did you identify any *wastewater treatment systems* in Table D-2?

- Yes (Continue)  
 No ([Skip to Part D Section 6.1](#))

Copy Section 5.1

**CRI?**  
 Yes

**D5-2.** In Table D-11, list all *wastewater treatment units* comprising the *wastewater treatment system* including units that are under construction/installation, or planned to be under construction/installation by December 31, 2020, included in the wastewater treatment system. For each wastewater treatment unit, assign an ID using the wastewater treatment unit terms provided in the drop down menu (e.g., Clarification, Primary-1), which will be used throughout the remainder of the survey; however, if a pond/impoundment unit is included as part of the wastewater treatment system, enter the pond/impoundment unit ID assigned in Table A-4 in the space labeled "Pond ID". The drop down menu accounts for the possibility of multiple wastewater treatment units; they are numbered sequentially. Note that these terms originated from the code tables on the "Code Tables" tab, provided at the end of this workbook.

For example, if the wastewater treatment system includes two clarifiers, select Clarification, Primary-1 for the first clarifier and Clarification, Secondary-1 for the second. In the "Plant Designation" column, provide the plant's name for each wastewater treatment unit. In the "Date Added to WWT System" column, either enter the date the unit was/will be installed if the unit is a retrofit, or enter "original" if the unit was part of the original wastewater treatment system installation.

**Table D-11. Wastewater Treatment Units**

| Wastewater Treatment Unit ID  | Plant Designation | Date Added to Wastewater Treatment System (day/month/year) | Volume (ft <sup>3</sup> ) | Footprint/ Surface Area (ft <sup>2</sup> ) | Residence Time (hours) | Materials of Construction [Check all boxes that apply.] |   |                                     |  |
|-------------------------------|-------------------|--|---------------------------|--|------------------------|---|---|-------------------------------------|--|
| <input type="text"/>          |                   |  |                           |  |                        | <input type="checkbox"/> 316L stain                     | <input type="checkbox"/> 255 stainl     | <input type="checkbox"/> Carbon s   |  |
| Other: <input type="text"/>   |                   |  |                           |  |                        | <input type="checkbox"/> 317LM stai                     | <input type="checkbox"/> 2205 stainless | <input type="checkbox"/> Fiberglass |  |
| Pond ID: <input type="text"/> |                   |  |                           |  |                        | <input type="checkbox"/> 317LMN sta                     | <input type="checkbox"/> 625 stainle    | <input type="checkbox"/> Iitanium   |  |
| <input type="text"/>          |                   |  |                           |  |                        | <input type="checkbox"/> Carbon steel                   | <input type="checkbox"/> Oth            |                                     |  |
| <input type="text"/>          |                   |  |                           |  |                        | <input type="checkbox"/> 316L stain                     | <input type="checkbox"/> 255 stainl     | <input type="checkbox"/> Carbon s   |  |
| Other: <input type="text"/>   |                   |  |                           |  |                        | <input type="checkbox"/> 317LM stai                     | <input type="checkbox"/> 2205 stainless | <input type="checkbox"/> Fiberglass |  |
| Pond ID: <input type="text"/> |                   |  |                           |  |                        | <input type="checkbox"/> 317LMN sta                     | <input type="checkbox"/> 625 stainle    | <input type="checkbox"/> Iitanium   |  |
| <input type="text"/>          |                   |  |                           |  |                        | <input type="checkbox"/> Carbon steel                   | <input type="checkbox"/> Oth            |                                     |  |
| <input type="text"/>          |                   |  |                           |  |                        | <input type="checkbox"/> 316L stain                     | <input type="checkbox"/> 255 stainl     | <input type="checkbox"/> Carbon s   |  |
| Other: <input type="text"/>   |                   |  |                           |  |                        | <input type="checkbox"/> 317LM stai                     | <input type="checkbox"/> 2205 stainless | <input type="checkbox"/> Fiberglass |  |
| Pond ID: <input type="text"/> |                   |  |                           |  |                        | <input type="checkbox"/> 317LMN sta                     | <input type="checkbox"/> 625 stainle    | <input type="checkbox"/> Iitanium   |  |
| <input type="text"/>          |                   |  |                           |  |                        | <input type="checkbox"/> Carbon steel                   | <input type="checkbox"/> Oth            |                                     |  |
| <input type="text"/>          |                   |  |                           |  |                        | <input type="checkbox"/> 316L stain                     | <input type="checkbox"/> 255 stainl     | <input type="checkbox"/> Carbon s   |  |
| Other: <input type="text"/>   |                   |  |                           |  |                        | <input type="checkbox"/> 317LM stai                     | <input type="checkbox"/> 2205 stainless | <input type="checkbox"/> Fiberglass |  |
| Pond ID: <input type="text"/> |                   |  |                           |  |                        | <input type="checkbox"/> 317LMN sta                     | <input type="checkbox"/> 625 stainle    | <input type="checkbox"/> Iitanium   |  |
| <input type="text"/>          |                   |  |                           |  |                        | <input type="checkbox"/> Carbon steel                   | <input type="checkbox"/> Oth            |                                     |  |

|          |  |  |  |  |  |                                      |   |                                     |
|----------|--|--|--|--|--|--------------------------------------|---|-------------------------------------|
|          |  |  |  |  |  | <input type="checkbox"/> 316L stain  | <input type="checkbox"/> 255 staink     | <input type="checkbox"/> Carbon c   |
| Other:   |  |  |  |  |  | <input type="checkbox"/> 317LM stai  | <input type="checkbox"/> 2205 stainless | <input type="checkbox"/> Fiberglass |
| Pond ID: |  |  |  |  |  | <input type="checkbox"/> 317LMN sta  | <input type="checkbox"/> 625 stainle    | <input type="checkbox"/> Titanium   |
|          |  |  |  |  |  | <input type="checkbox"/> Carbon stee | <input type="checkbox"/> Oth            |                                     |
|          |  |  |  |  |  | <input type="checkbox"/> 316L stain  | <input type="checkbox"/> 255 staink     | <input type="checkbox"/> Carbon s   |
| Other:   |  |  |  |  |  | <input type="checkbox"/> 317LM stai  | <input type="checkbox"/> 2205 stainless | <input type="checkbox"/> Fiberglass |
| Pond ID: |  |  |  |  |  | <input type="checkbox"/> 317LMN sta  | <input type="checkbox"/> 625 stainle    | <input type="checkbox"/> Titanium   |
|          |  |  |  |  |  | <input type="checkbox"/> Carbon stee | <input type="checkbox"/> Oth            |                                     |
|          |  |  |  |  |  | <input type="checkbox"/> 316L stain  | <input type="checkbox"/> 255 staink     | <input type="checkbox"/> Carbon c   |
| Other:   |  |  |  |  |  | <input type="checkbox"/> 317LM stai  | <input type="checkbox"/> 2205 stainless | <input type="checkbox"/> Fiberglass |
| Pond ID: |  |  |  |  |  | <input type="checkbox"/> 317LMN sta  | <input type="checkbox"/> 625 stainle    | <input type="checkbox"/> Titanium   |
|          |  |  |  |  |  | <input type="checkbox"/> Carbon stee | <input type="checkbox"/> Oth            |                                     |
|          |  |  |  |  |  | <input type="checkbox"/> 316L stain  | <input type="checkbox"/> 255 staink     | <input type="checkbox"/> Carbon s   |
| Other:   |  |  |  |  |  | <input type="checkbox"/> 317LM stai  | <input type="checkbox"/> 2205 stainless | <input type="checkbox"/> Fiberglass |
| Pond ID: |  |  |  |  |  | <input type="checkbox"/> 317LMN sta  | <input type="checkbox"/> 625 stainle    | <input type="checkbox"/> Titanium   |
|          |  |  |  |  |  | <input type="checkbox"/> Carbon stee | <input type="checkbox"/> Oth            |                                     |
|          |  |  |  |  |  | <input type="checkbox"/> 316L stain  | <input type="checkbox"/> 255 staink     | <input type="checkbox"/> Carbon c   |
| Other:   |  |  |  |  |  | <input type="checkbox"/> 317LM stai  | <input type="checkbox"/> 2205 stainless | <input type="checkbox"/> Fiberglass |
| Pond ID: |  |  |  |  |  | <input type="checkbox"/> 317LMN sta  | <input type="checkbox"/> 625 stainle    | <input type="checkbox"/> Titanium   |
|          |  |  |  |  |  | <input type="checkbox"/> Carbon stee | <input type="checkbox"/> Oth            |                                     |
|          |  |  |  |  |  | <input type="checkbox"/> 316L stain  | <input type="checkbox"/> 255 staink     | <input type="checkbox"/> Carbon s   |
| Other:   |  |  |  |  |  | <input type="checkbox"/> 317LM stai  | <input type="checkbox"/> 2205 stainless | <input type="checkbox"/> Fiberglass |
| Pond ID: |  |  |  |  |  | <input type="checkbox"/> 317LMN sta  | <input type="checkbox"/> 625 stainle    | <input type="checkbox"/> Titanium   |
|          |  |  |  |  |  | <input type="checkbox"/> Carbon stee | <input type="checkbox"/> Oth            |                                     |
|          |  |  |  |  |  | <input type="checkbox"/> 316L stain  | <input type="checkbox"/> 255 staink     | <input type="checkbox"/> Carbon c   |
| Other:   |  |  |  |  |  | <input type="checkbox"/> 317LM stai  | <input type="checkbox"/> 2205 stainless | <input type="checkbox"/> Fiberglass |
| Pond ID: |  |  |  |  |  | <input type="checkbox"/> 317LMN sta  | <input type="checkbox"/> 625 stainle    | <input type="checkbox"/> Titanium   |
|          |  |  |  |  |  | <input type="checkbox"/> Carbon stee | <input type="checkbox"/> Oth            |                                     |
|          |  |  |  |  |  | <input type="checkbox"/> 316L stain  | <input type="checkbox"/> 255 staink     | <input type="checkbox"/> Carbon s   |
| Other:   |  |  |  |  |  | <input type="checkbox"/> 317LM stai  | <input type="checkbox"/> 2205 stainless | <input type="checkbox"/> Fiberglass |
| Pond ID: |  |  |  |  |  | <input type="checkbox"/> 317LMN sta  | <input type="checkbox"/> 625 stainle    | <input type="checkbox"/> Titanium   |
|          |  |  |  |  |  | <input type="checkbox"/> Carbon stee | <input type="checkbox"/> Oth            |                                     |
|          |  |  |  |  |  | <input type="checkbox"/> 316L stain  | <input type="checkbox"/> 255 staink     | <input type="checkbox"/> Carbon c   |
| Other:   |  |  |  |  |  | <input type="checkbox"/> 317LM stai  | <input type="checkbox"/> 2205 stainless | <input type="checkbox"/> Fiberglass |
| Pond ID: |  |  |  |  |  | <input type="checkbox"/> 317LMN sta  | <input type="checkbox"/> 625 stainle    | <input type="checkbox"/> Titanium   |
|          |  |  |  |  |  | <input type="checkbox"/> Carbon stee | <input type="checkbox"/> Oth            |                                     |

|          |  |  |  |  |  |                                     |   |                                     |
|----------|--|--|--|--|--|-------------------------------------|---|-------------------------------------|
|          |  |  |  |  |  | <input type="checkbox"/> 316L stain | <input type="checkbox"/> 255 stainle    | <input type="checkbox"/> Carbon s   |
| Other:   |  |  |  |  |  | <input type="checkbox"/> 317LM stai | <input type="checkbox"/> 2205 stainless | <input type="checkbox"/> Fiberglass |
| Pond ID: |  |  |  |  |  | <input type="checkbox"/> 317LMN sta | <input type="checkbox"/> 625 stainle    | <input type="checkbox"/> titanium   |
|          |  |  |  |  |  | <input type="checkbox"/> Carbon ste | <input type="checkbox"/> Oth            |                                     |
|          |  |  |  |  |  | <input type="checkbox"/> 316L stain | <input type="checkbox"/> 255 stainle    | <input type="checkbox"/> Carbon s   |
| Other:   |  |  |  |  |  | <input type="checkbox"/> 317LM stai | <input type="checkbox"/> 2205 stainless | <input type="checkbox"/> Fiberglass |
| Pond ID: |  |  |  |  |  | <input type="checkbox"/> 317LMN sta | <input type="checkbox"/> 625 stainle    | <input type="checkbox"/> titanium   |
|          |  |  |  |  |  | <input type="checkbox"/> Carbon ste | <input type="checkbox"/> Oth            |                                     |
|          |  |  |  |  |  | <input type="checkbox"/> 316L stain | <input type="checkbox"/> 255 stainle    | <input type="checkbox"/> Carbon s   |
| Other:   |  |  |  |  |  | <input type="checkbox"/> 317LM stai | <input type="checkbox"/> 2205 stainless | <input type="checkbox"/> Fiberglass |
| Pond ID: |  |  |  |  |  | <input type="checkbox"/> 317LMN sta | <input type="checkbox"/> 625 stainle    | <input type="checkbox"/> titanium   |
|          |  |  |  |  |  | <input type="checkbox"/> Carbon ste | <input type="checkbox"/> Oth            |                                     |
|          |  |  |  |  |  | <input type="checkbox"/> 316L stain | <input type="checkbox"/> 255 stainle    | <input type="checkbox"/> Carbon s   |
| Other:   |  |  |  |  |  | <input type="checkbox"/> 317LM stai | <input type="checkbox"/> 2205 stainless | <input type="checkbox"/> Fiberglass |
| Pond ID: |  |  |  |  |  | <input type="checkbox"/> 317LMN sta | <input type="checkbox"/> 625 stainle    | <input type="checkbox"/> titanium   |
|          |  |  |  |  |  | <input type="checkbox"/> Carbon ste | <input type="checkbox"/> Oth            |                                     |

CBI?  
 Yes

D5-3. Provide the design flow rate for the wastewater treatment system, as well as both the average and maximum flow rates for 2009. In addition, provide the duration and frequency of the effluent transfers from the wastewater treatment system in 2009. If the wastewater treatment system is planned, only provide the design flow rate and enter "NA" in all other fields.

- Average design flow rate, gpm
- Maximum design flow rate, gpm
- Typical flow rate in 2009, gpm
- Maximum daily flow rate in 2009, gpm
- Maximum daily flow rate in 2009, gpd
- Duration of effluent transfers from treatment system in 2009, hpd
- Frequency of effluent transfers from treatment system in 2009, dpy

CBI?  
 Yes

D5-4. Indicate the pollutants targeted for removal by this wastewater treatment system using techniques other than solely settling (e.g., adding chemicals to remove certain metals). [Check all boxes that apply.]

- Metals (sp )
- TSS
- Nitrogen compounds (am )
- Organic
- Chlorine or other o )
- Oil and grea
- Other:
- NA  (kip to Question D5-6)

CBI?  Yes:

D5-5. Of the pollutants listed in D5-4, which effluent limitation(s) drives/will drive the operation of this pond/impoundment unit? Provide the pollutant and the limitation (mg/L or ug/L).

Pollutant:

Limitation:

Pollutant:

Limitation:

Pollutant:

Limitation:

CBI?  Yes:

D5-6. Is this wastewater treatment system capable of performing sulfide addition?

- Yes (Continue)
- No (Skip to Question D5-8)

CBI?  Yes:

D5-7. Is the plant currently performing sulfide addition?

- Yes
- No

CBI?  Yes:

D5-8. Provide information on any impacts that climate had, or will have, on the installation of the wastewater treatment system (e.g., equipment had to be housed inside due to cold winters, extra insulation was necessary to protect equipment in winter, warm climate allowed all wastewater treatment to be located outdoors).

CBI?  Yes:

D5-9. Provide information on any impacts that space availability had, or will have, on the design and/or cost of the wastewater treatment system (e.g., cost increases due to fitting the wastewater treatment system units into tight spaces and/or moving other equipment to accommodate the treatment system units).

CBI?  Yes:

D5-10. Provide the bid proposals and/or engineering reports that were prepared for the wastewater treatment system.

**Note: All bid proposals and/or engineering reports originally submitted to the plant as CBI, should be marked CBI for the purpose of this collection request.**

- I have attached the bid propos
- I did not attach the bid proposals/engir

CBI?  Yes:

D5-11. In Table D-12, list all planned improvements (including those currently under construction/installation or those planned to be under construction/installation by December 31, 2020) to the wastewater treatment system. For each planned improvement to the wastewater treatment system, provide the WWT Unit ID the improvement pertains to (if applicable), using the terms in the drop down menu; however, if the improvement relates directly to a pond/impoundment, use the pond/impoundment ID assigned in Table A-4. Provide a description of the improvement, the expected date of the improvement, and the total capital cost related to the improvement.

**Note: Total capital costs should include purchased equipment, installation, buildings, site preparation, land, engineering costs, construction expenses, and any other costs available.**

**Table D-12. Planned Improvements to the Wastewater Treatment System**

| Wastewater Treatment Unit ID   | Description of Improvement | Expected Date of Improvement (day/month/year) | Total Capital Cost (\$) |
|--------------------------------|----------------------------|---|-------------------------|
| Other: _____<br>Pond ID: _____ |                            |   |                         |
| Other: _____<br>Pond ID: _____ |                            |   |                         |
| Other: _____<br>Pond ID: _____ |                            |   |                         |
| Other: _____<br>Pond ID: _____ |                            |   |                         |
| Other: _____<br>Pond ID: _____ |                            |   |                         |
| Other: _____<br>Pond ID: _____ |                            |   |                         |

**CRI?**  
 Yes

**D5-12.** Were any of the above planned improvements to the wastewater treatment system, or the planned wastewater treatment system, planned in preparation for potential limit changes in the future?

- Yes (Continue)
- No (Skip to Section 5.2)

Please identify which pollutants and/or limits, in particular, the improvements or system will target.

Plant ID: Insert Plant ID  
 Plant Name: Insert Plant Name  
 Wastewater Treatment System ID: Insert System ID

**Part: D**  
**Section Title:** 5.2. Wastewater Treatment System Chemical Addition

**Instructions:** Complete Section 5.2 (Question D5-13) for each *wastewater treatment system* identified in Table D-2 (including those under construction/installation or planned to be under construction/installation by December 31, 2020). Do NOT complete Questions D5-8 through D5-12 for *pond/impoundment units* that are part of a wastewater treatment system (e.g. a pond/impoundment unit which is part of a biological wastewater treatment system). Enter the wastewater treatment system ID in the spaces provided above (use wastewater treatment system IDs assigned in Table D-2).

Make a copy of Section 5.2 for each wastewater treatment system identified in Table D-2 using the "Copy Section 5.2" button below.

Copy Section 5.2

CBI?  
 Yes

**D5-13.** Did the plant add chemicals to any *wastewater treatment units* 2009?

- Yes (Complete Table D-13)
- No (Skip to Section 6.1)
- No (Wastewater treatment unit is planned to be constructed. Provide information in Table D-13 to the extent possible based on plans.)

Complete Table D-13 for each unit (as defined in Table D-11) that chemicals are added to in the wastewater treatment system. Complete a row for each chemical added to each unit in the system.

Note that "Chemical Type" refers to the generic name of the chemical added to the wastewater treatment unit (e.g., lime, organosulfide). "Average Dose Concentration" refers to the average concentration of the chemical within the wastewater treatment unit just after it is added to the unit. If chemical addition is known only on a yearly basis, divide the yearly value by the approximate number of days the plant added chemicals (which should be the same estimate for the "Frequency of Addition" column).

**Table D-13. Chemicals Used in Wastewater Treatment Unit Operations**

| Wastewater Treatment Unit ID (Identified in Table D-11) | Chemical Type | Trade Name | Manufacturer | Purpose | Average Dose Concentration (g/L) | Average Addition Rate (gpd or lb/day) |                            | Frequency of Addition (dpy) |
|---|---------------|------------|--------------|---------|----------------------------------|---------------------------------------|----------------------------|-----------------------------|
|   |               |            |              |         |                                  | <input type="radio"/> gpd             | <input type="radio"/> Soli |                             |
| Other: <input type="text"/>                             |               |            |              |         |                                  | <input type="radio"/> lb/d            | <input type="radio"/> Lic  |                             |
| Other: <input type="text"/>                             |               |            |              |         |                                  | <input type="radio"/> gp              | <input type="radio"/> So   |                             |
| Other: <input type="text"/>                             |               |            |              |         |                                  | <input type="radio"/> lb/             | <input type="radio"/> Liq  |                             |
| Other: <input type="text"/>                             |               |            |              |         |                                  | <input type="radio"/> g/              | <input type="radio"/> Sol  |                             |
| Other: <input type="text"/>                             |               |            |              |         |                                  | <input type="radio"/> lb/             | <input type="radio"/> Liq  |                             |
| Other: <input type="text"/>                             |               |            |              |         |                                  | <input type="radio"/> g/              | <input type="radio"/> Soli |                             |
| Other: <input type="text"/>                             |               |            |              |         |                                  | <input type="radio"/> lb/c            | <input type="radio"/> Lic  |                             |
| Other: <input type="text"/>                             |               |            |              |         |                                  | <input type="radio"/> g/              | <input type="radio"/> Sc   |                             |
| Other: <input type="text"/>                             |               |            |              |         |                                  | <input type="radio"/> lb/             | <input type="radio"/> Liq  |                             |
| Other: <input type="text"/>                             |               |            |              |         |                                  | <input type="radio"/> gpd             | <input type="radio"/> Soli |                             |
| Other: <input type="text"/>                             |               |            |              |         |                                  | <input type="radio"/> lb/d            | <input type="radio"/> Lic  |                             |
| Other: <input type="text"/>                             |               |            |              |         |                                  | <input type="radio"/> gp              | <input type="radio"/> So   |                             |
| Other: <input type="text"/>                             |               |            |              |         |                                  | <input type="radio"/> lb/             | <input type="radio"/> Liq  |                             |

|        |  |  |  |  |  |  |  |                            |                            |  |
|--------|--|--|--|--|--|--|--|----------------------------|----------------------------|--|
|        |  |  |  |  |  |  |  | <input type="radio"/> gp   | <input type="radio"/> Sol  |  |
| Other: |  |  |  |  |  |  |  | <input type="radio"/> lb/i | <input type="radio"/> Liq  |  |
|        |  |  |  |  |  |  |  | <input type="radio"/> gp   | <input type="radio"/> Soli |  |
| Other: |  |  |  |  |  |  |  | <input type="radio"/> lb/c | <input type="radio"/> Lic  |  |
|        |  |  |  |  |  |  |  | <input type="radio"/> gp   | <input type="radio"/> Sc   |  |
| Other: |  |  |  |  |  |  |  | <input type="radio"/> lb/i | <input type="radio"/> Liq  |  |
|        |  |  |  |  |  |  |  | <input type="radio"/> gp   | <input type="radio"/> Soli |  |
| Other: |  |  |  |  |  |  |  | <input type="radio"/> lb/d | <input type="radio"/> Lic  |  |
|        |  |  |  |  |  |  |  | <input type="radio"/> gp   | <input type="radio"/> So   |  |
| Other: |  |  |  |  |  |  |  | <input type="radio"/> lb/  | <input type="radio"/> Liq  |  |
|        |  |  |  |  |  |  |  | <input type="radio"/> gp   | <input type="radio"/> Sol  |  |
| Other: |  |  |  |  |  |  |  | <input type="radio"/> lb/i | <input type="radio"/> Liq  |  |
|        |  |  |  |  |  |  |  | <input type="radio"/> gp   | <input type="radio"/> Soli |  |
| Other: |  |  |  |  |  |  |  | <input type="radio"/> lb/c | <input type="radio"/> Lic  |  |
|        |  |  |  |  |  |  |  | <input type="radio"/> gp   | <input type="radio"/> Sc   |  |
| Other: |  |  |  |  |  |  |  | <input type="radio"/> lb/i | <input type="radio"/> Liq  |  |
|        |  |  |  |  |  |  |  | <input type="radio"/> gp   | <input type="radio"/> Soli |  |
| Other: |  |  |  |  |  |  |  | <input type="radio"/> lb/d | <input type="radio"/> Lic  |  |
|        |  |  |  |  |  |  |  | <input type="radio"/> gp   | <input type="radio"/> So   |  |
| Other: |  |  |  |  |  |  |  | <input type="radio"/> lb/  | <input type="radio"/> Liq  |  |
|        |  |  |  |  |  |  |  | <input type="radio"/> gp   | <input type="radio"/> Sol  |  |
| Other: |  |  |  |  |  |  |  | <input type="radio"/> lb/i | <input type="radio"/> Liq  |  |
|        |  |  |  |  |  |  |  | <input type="radio"/> gp   | <input type="radio"/> Soli |  |
| Other: |  |  |  |  |  |  |  | <input type="radio"/> lb/c | <input type="radio"/> Lic  |  |
|        |  |  |  |  |  |  |  | <input type="radio"/> gp   | <input type="radio"/> Sc   |  |
| Other: |  |  |  |  |  |  |  | <input type="radio"/> lb/i | <input type="radio"/> Liq  |  |
|        |  |  |  |  |  |  |  | <input type="radio"/> gp   | <input type="radio"/> Soli |  |
| Other: |  |  |  |  |  |  |  | <input type="radio"/> lb/d | <input type="radio"/> Lic  |  |
|        |  |  |  |  |  |  |  | <input type="radio"/> gp   | <input type="radio"/> So   |  |
| Other: |  |  |  |  |  |  |  | <input type="radio"/> lb/  | <input type="radio"/> Liq  |  |



|        |  |  |  |  |  |  |  |                            |                            |  |
|--------|--|--|--|--|--|--|--|----------------------------|----------------------------|--|
|        |  |  |  |  |  |  |  | <input type="radio"/> g/c  | <input type="radio"/> Sol  |  |
| Other: |  |  |  |  |  |  |  | <input type="radio"/> lb/i | <input type="radio"/> Liq  |  |
|        |  |  |  |  |  |  |  | <input type="radio"/> g/c  | <input type="radio"/> Soli |  |
| Other: |  |  |  |  |  |  |  | <input type="radio"/> lb/c | <input type="radio"/> Lic  |  |
|        |  |  |  |  |  |  |  | <input type="radio"/> g/c  | <input type="radio"/> Sc   |  |
| Other: |  |  |  |  |  |  |  | <input type="radio"/> lb/i | <input type="radio"/> Liq  |  |
|        |  |  |  |  |  |  |  | <input type="radio"/> gp   | <input type="radio"/> Soli |  |
| Other: |  |  |  |  |  |  |  | <input type="radio"/> lb/d | <input type="radio"/> Lic  |  |
|        |  |  |  |  |  |  |  | <input type="radio"/> gp   | <input type="radio"/> So   |  |
| Other: |  |  |  |  |  |  |  | <input type="radio"/> lb/  | <input type="radio"/> Liq  |  |
|        |  |  |  |  |  |  |  | <input type="radio"/> g/c  | <input type="radio"/> Sol  |  |
| Other: |  |  |  |  |  |  |  | <input type="radio"/> lb/i | <input type="radio"/> Liq  |  |
|        |  |  |  |  |  |  |  | <input type="radio"/> g/c  | <input type="radio"/> Soli |  |
| Other: |  |  |  |  |  |  |  | <input type="radio"/> lb/c | <input type="radio"/> Lic  |  |
|        |  |  |  |  |  |  |  | <input type="radio"/> g/c  | <input type="radio"/> Sc   |  |
| Other: |  |  |  |  |  |  |  | <input type="radio"/> lb/i | <input type="radio"/> Liq  |  |
|        |  |  |  |  |  |  |  | <input type="radio"/> gp   | <input type="radio"/> Soli |  |
| Other: |  |  |  |  |  |  |  | <input type="radio"/> lb/d | <input type="radio"/> Lic  |  |
|        |  |  |  |  |  |  |  | <input type="radio"/> gp   | <input type="radio"/> So   |  |
| Other: |  |  |  |  |  |  |  | <input type="radio"/> lb/  | <input type="radio"/> Liq  |  |
|        |  |  |  |  |  |  |  | <input type="radio"/> g/c  | <input type="radio"/> Sol  |  |
| Other: |  |  |  |  |  |  |  | <input type="radio"/> lb/i | <input type="radio"/> Liq  |  |
|        |  |  |  |  |  |  |  | <input type="radio"/> g/c  | <input type="radio"/> Soli |  |
| Other: |  |  |  |  |  |  |  | <input type="radio"/> lb/c | <input type="radio"/> Lic  |  |
|        |  |  |  |  |  |  |  | <input type="radio"/> g/c  | <input type="radio"/> Sc   |  |
| Other: |  |  |  |  |  |  |  | <input type="radio"/> lb/i | <input type="radio"/> Liq  |  |
|        |  |  |  |  |  |  |  | <input type="radio"/> gp   | <input type="radio"/> Soli |  |
| Other: |  |  |  |  |  |  |  | <input type="radio"/> lb/d | <input type="radio"/> Lic  |  |
|        |  |  |  |  |  |  |  | <input type="radio"/> gp   | <input type="radio"/> So   |  |
| Other: |  |  |  |  |  |  |  | <input type="radio"/> lb/  | <input type="radio"/> Liq  |  |
|        |  |  |  |  |  |  |  | <input type="radio"/> g/c  | <input type="radio"/> Sol  |  |
| Other: |  |  |  |  |  |  |  | <input type="radio"/> lb/i | <input type="radio"/> Liq  |  |

|        |  |  |  |  |  |  |  |                            |                            |  |
|--------|--|--|--|--|--|--|--|----------------------------|----------------------------|--|
|        |  |  |  |  |  |  |  | <input type="radio"/> g/c  | <input type="radio"/> Soli |  |
| Other: |  |  |  |  |  |  |  | <input type="radio"/> lb/c | <input type="radio"/> Lic  |  |
|        |  |  |  |  |  |  |  | <input type="radio"/> g/c  | <input type="radio"/> Sc   |  |
| Other: |  |  |  |  |  |  |  | <input type="radio"/> lb/l | <input type="radio"/> Liq  |  |
|        |  |  |  |  |  |  |  | <input type="radio"/> g/d  | <input type="radio"/> Soli |  |
| Other: |  |  |  |  |  |  |  | <input type="radio"/> lb/d | <input type="radio"/> Lic  |  |
|        |  |  |  |  |  |  |  | <input type="radio"/> g/p  | <input type="radio"/> So   |  |
| Other: |  |  |  |  |  |  |  | <input type="radio"/> lb/l | <input type="radio"/> Liq  |  |
|        |  |  |  |  |  |  |  | <input type="radio"/> g/c  | <input type="radio"/> Sol  |  |
| Other: |  |  |  |  |  |  |  | <input type="radio"/> lb/l | <input type="radio"/> Liq  |  |
|        |  |  |  |  |  |  |  | <input type="radio"/> g/c  | <input type="radio"/> Soli |  |
| Other: |  |  |  |  |  |  |  | <input type="radio"/> lb/c | <input type="radio"/> Lic  |  |
|        |  |  |  |  |  |  |  | <input type="radio"/> g/c  | <input type="radio"/> Sc   |  |
| Other: |  |  |  |  |  |  |  | <input type="radio"/> lb/l | <input type="radio"/> Liq  |  |
|        |  |  |  |  |  |  |  | <input type="radio"/> g/p  | <input type="radio"/> Soli |  |
| Other: |  |  |  |  |  |  |  | <input type="radio"/> lb/d | <input type="radio"/> Lic  |  |
|        |  |  |  |  |  |  |  | <input type="radio"/> g/p  | <input type="radio"/> So   |  |
| Other: |  |  |  |  |  |  |  | <input type="radio"/> lb/l | <input type="radio"/> Liq  |  |
|        |  |  |  |  |  |  |  | <input type="radio"/> g/c  | <input type="radio"/> Sol  |  |
| Other: |  |  |  |  |  |  |  | <input type="radio"/> lb/l | <input type="radio"/> Liq  |  |
|        |  |  |  |  |  |  |  | <input type="radio"/> g/c  | <input type="radio"/> Soli |  |
| Other: |  |  |  |  |  |  |  | <input type="radio"/> lb/c | <input type="radio"/> Lic  |  |
|        |  |  |  |  |  |  |  | <input type="radio"/> g/c  | <input type="radio"/> Sc   |  |
| Other: |  |  |  |  |  |  |  | <input type="radio"/> lb/l | <input type="radio"/> Liq  |  |
|        |  |  |  |  |  |  |  | <input type="radio"/> g/p  | <input type="radio"/> Soli |  |
| Other: |  |  |  |  |  |  |  | <input type="radio"/> lb/d | <input type="radio"/> Lic  |  |
|        |  |  |  |  |  |  |  | <input type="radio"/> g/p  | <input type="radio"/> So   |  |
| Other: |  |  |  |  |  |  |  | <input type="radio"/> lb/l | <input type="radio"/> Liq  |  |
|        |  |  |  |  |  |  |  | <input type="radio"/> g/c  | <input type="radio"/> Sol  |  |
| Other: |  |  |  |  |  |  |  | <input type="radio"/> lb/l | <input type="radio"/> Liq  |  |
|        |  |  |  |  |  |  |  | <input type="radio"/> g/c  | <input type="radio"/> Soli |  |
| Other: |  |  |  |  |  |  |  | <input type="radio"/> lb/c | <input type="radio"/> Lic  |  |
|        |  |  |  |  |  |  |  | <input type="radio"/> g/c  | <input type="radio"/> Sc   |  |
| Other: |  |  |  |  |  |  |  | <input type="radio"/> lb/l | <input type="radio"/> Liq  |  |

Plant ID: Insert Plant ID

Plant Name: Insert Plant Name

Pond/Impoundment System ID or Wastewater Treatment System ID: Insert System ID

**Part: D**

**Section Title: 6.1. Pond/Impoundment System and Wastewater Treatment System Costs**

**Instructions:** Complete Sections 6.1 and 6.2 (Questions D6-1 through D6-6) for each *pond/impoundment system* and/or *wastewater treatment system* identified in Table D-1 and Table D-2 that was installed (or is planned to be installed) at the plant on or after January 1, 1985. Enter the pond/impoundment system ID or wastewater treatment system ID in the space provided above (use pond/impoundment system IDs and wastewater treatment system IDs assigned in Table D-1 and Table D-2).

Make a copy of Sections 6.1 and 6.2 for each pond/impoundment system and/or wastewater treatment system identified in Table D-1 and Table D-2 using the "Copy Section 6.1 and 6.2" button below. Just pressing this button once will generate copies of both tabs.

**CBI?**  
 Yes

**D6-1.** Were any of the pond/impoundment systems and/or wastewater treatment systems identified in Table D-1 or Table D-2 installed (or planned to be installed) after January 1, 1985?

- Yes (Continue)
- No (Skip to next Questionnaire Part)

Copy Section 6.1 and 6.2

**CBI?**  
 Yes

**D6-2.** Provide annual O&M cost data in Table D-14 for each pond/impoundment system and wastewater treatment system identified in Table D-1 and Table D-2 (installed or planned to be installed after January 1, 1985) that was operated in 2009. Provide best engineering estimates when actual data are not readily available. If you provide an estimate, note the methods that were used to make the estimates in the Comments page.

**Table D-14. O&M Cost for the Pond/Impoundment System or Wastewater Treatment System for 2009**

| O&M Cost Category     | 2009 Annual Cost  | 2009 Rate  | 2009 Staffing/ Consumption  |
|-----------------------|---|--|---|
| Operating labor       | \$ <input style="background-color: yellow;" type="text"/> | \$ <input style="background-color: yellow;" type="text"/> per hour (average rate of labor) | <input style="background-color: yellow;" type="text"/> No. of workers<br><input style="background-color: yellow;" type="text"/> hpd<br><input style="background-color: yellow;" type="text"/> dpy |
| Maintenance labor     | \$ <input style="background-color: yellow;" type="text"/> | \$ <input style="background-color: yellow;" type="text"/> per hour (average rate of labor) | <input style="background-color: yellow;" type="text"/> No. of workers<br><input style="background-color: yellow;" type="text"/> hpd<br><input style="background-color: yellow;" type="text"/> dpy |
| Maintenance materials | \$ <input style="background-color: yellow;" type="text"/> |  |   |
| Chemicals             | \$ <input style="background-color: yellow;" type="text"/> |  |   |

|  |               |   |                      |
|--|---------------|---|----------------------|
| Energy - Power for pumping                       | \$ [redacted] | \$ [redacted] per kWh   | [redacted] kWh/hr    |
| Energy - Power for operations other than pumping | \$ [redacted] | \$ [redacted] per kWh   | [redacted] kWh/hr    |
| Steam  | \$ [redacted] | \$ [redacted] per pound   | [redacted] pounds/hr |
| Hazardous Sludge Disposal - Dredging             | \$ [redacted] | \$ [redacted] per <input type="radio"/> Gallon<br><input type="radio"/> Ton |                      |
| Hazardous Sludge Disposal - Landfilling          | \$ [redacted] | \$ [redacted] per <input type="radio"/> Gallon<br><input type="radio"/> Ton |                      |
| Nonhazardous Sludge Disposal - Dredging          | \$ [redacted] | \$ [redacted] per <input type="radio"/> Gallon<br><input type="radio"/> Ton |                      |
| Nonhazardous Sludge Disposal - Landfilling       | \$ [redacted] | \$ [redacted] per <input type="radio"/> Gallon<br><input type="radio"/> Ton |                      |
| Other:   | \$ [redacted] |   |                      |
| Other:   | \$ [redacted] |   |                      |
| <b>Total O&amp;M Cost (2009)</b>                 | \$ [redacted] |   |                      |

**CBI?**  
 Yes

**D6-3.** Provide cost data in Table D-15 for each pond/impoundment systems and wastewater treatment system identified in Table D-1 and Table D-2 (installed or planned to be installed after January 1, 1985), including retired/closed pond/impoundment systems, planned pond/impoundment systems, and planned wastewater treatment systems (including those under construction/installation or planned to be under construction/installation by December 31, 2020). Provide best engineering estimates when actual data are not readily available. For all costs, do not adjust for inflation. For example, if the plant incurred a land cost in 2002, enter the cost in the "Cost" column and enter "2002" in the "Year on which Cost is Based" column.

**NOTE:** If no records are available on this wastewater treatment system, provide an explanation in the Comments page.

**Table D-15. Capital Cost for the Pond/Impoundment System or Wastewater Treatment System**

| Project   | Cost | Year on which Cost is Based |
|---|------|-----------------------------|
| <b>Direct Costs</b>   |      |                             |
| <u>Purchased equipment</u> (includes all equipment for the installation or the upgrade: mechanical equipment; piping; instrumentation; electrical equipment; spare parts; freight charges; taxes; insurance; and duties)  | \$   |                             |
| <u>Purchased equipment installation</u> (includes installation of all equipment; piping; instrumentation/calibration; electrical equipment; mechanical equipment; structural supports, insulation, and paint)   | \$   |                             |
| <u>Buildings</u> (buildings constructed to house ash handling system components, operator rooms, or other operations associated with the system; also includes plumbing, heating, ventilation, dust collection, air conditioning, lighting, telephones, intercoms, painting, sprinklers, fire alarms) | \$   |                             |
| <u>Site preparation</u> (includes site clearing, all demolition, grading, roads, walking areas, fences)   | \$   |                             |
| <u>Land</u> (includes property costs and survey fees)   | \$   |                             |
| <b>Total Direct Costs</b>   | \$   |                             |
| <b>Indirect Costs</b>   |      |                             |
| <u>Engineering Costs</u> (includes process design and general engineering, cost engineering, consulting fees, supervision, inspection for each category below:<br><br>a. Engineering Contract Firm Costs<br>b. Owner's Overhead Engineering Costs)  | \$   |                             |
| <input type="checkbox"/> <u>Hired outside engineering firm to oversee design and/or</u>   |      |                             |
| <u>Construction expenses</u> (includes temporary construction offices, roads, communications, fencing; construction tools and equipment; permits, taxes, insurance)   | \$   |                             |
| <u>Other Contractor's Fees</u>  | \$   |                             |
| <u>Contingency actually expended</u> (to compensate for unpredictable events such as storms, floods, strikes, price changes, errors in estimates, design changes, etc.)   | \$   |                             |
| <b>Total Indirect Costs</b>   | \$   |                             |
| <b>Total Capital Cost</b>   | \$   |                             |

**CBI?** Yes

**D6-4.** If applicable, indicate whether the FGD wastewater treatment system, for which the plant provided capital cost data in Table D-15, was a retrofit or was installed when the *FGD scrubber system* was installed.

- FGD wastewater treatment system was a retro
- FGD wastewater treatment system was installed when the F
- NA

**CBI?** Yes

**D6-5.** If applicable, indicate whether the FGD wastewater treatment system, for which the plant provide capital cost data in Table D-15, was purchased as part of the FGD scrubber package.

- FGD wastewater treatment system was purchased as par
- FGD wastewater treatment system was not purchased as p
- NA

Plant ID: Insert Plant ID

Plant Name: Insert Plant Name

Pond/Impoundment System ID or Wastewater Treatment System ID: Insert System ID

**Part: D**

**Section Title:** 6.2. Pond/Impoundment System and Wastewater Treatment System Equipment

**Instructions:** Complete Section 6.2 (Question D6-6) for all ancillary pieces of equipment included in the *pond/impoundment system* or *wastewater treatment system* that contribute to the capital costs provided in Table D-15.

~~Note: This tab will copy with every copy made for the previous tab (Part D Section 6.1) as the~~

**CBI?**  
 Yes

**D6-6.** In Table D-16, list any ancillary pieces of equipment (i.e., equipment such as pumps and agitators) included in the pond/impoundment system or wastewater treatment system that contribute significantly to the capital costs provided in Table D-16 and provide the total number of pieces of that equipment included in the system. Refer to the examples of ancillary equipment shown below.

Examples of ancillary equipment:

Aerator

Agitator

Chemical feed system (specify chemicals)

Pump, sludge (specify purpose/location)

Pump, wastewater (specify purpose/location)







|  |  |
|--|--|
|  |  |
|  |  |

Plant ID: Insert Plant ID  
Plant Name: Insert Plant Name

|  |
|--|
| <p><b>Part:</b> D</p> <p><b>Section Title:</b> Part D Comments</p> <p><b>Instructions:</b> Cross reference your comments by question number and indicate the confidential status of your comment by checking the box next to "Yes" under "CBI?" (Confidential Business Information).</p> |
|--|

| Question Number                      | Comments |
|--------------------------------------|----------|
| CBI?<br><input type="checkbox"/> Yes |          |
| CBI?<br><input type="checkbox"/> Yes |          |
| CBI?<br><input type="checkbox"/> Yes |          |
| CBI?<br><input type="checkbox"/> Yes |          |
| CBI?<br><input type="checkbox"/> Yes |          |
| CBI?<br><input type="checkbox"/> Yes |          |
| CBI?<br><input type="checkbox"/> Yes |          |
| CBI?<br><input type="checkbox"/> Yes |          |
| CBI?<br><input type="checkbox"/> Yes |          |
| CBI?<br><input type="checkbox"/> Yes |          |
| CBI?<br><input type="checkbox"/> Yes |          |
| CBI?<br><input type="checkbox"/> Yes |          |
| CBI?<br><input type="checkbox"/> Yes |          |
| CBI?<br><input type="checkbox"/> Yes |          |
| CBI?<br><input type="checkbox"/> Yes |          |
| CBI?<br><input type="checkbox"/> Yes |          |
| CBI?<br><input type="checkbox"/> Yes |          |
| CBI?<br><input type="checkbox"/> Yes |          |
| CBI?<br><input type="checkbox"/> Yes |          |
| CBI?<br><input type="checkbox"/> Yes |          |
| CBI?<br><input type="checkbox"/> Yes |          |

|  |  |
|--|--|
| <input type="checkbox"/> <b>CRI2</b><br><input type="checkbox"/> Yes |  |
| <input type="checkbox"/> <b>CRI2</b><br><input type="checkbox"/> Yes |  |
| <input type="checkbox"/> <b>CRI2</b><br><input type="checkbox"/> Yes |  |
| <input type="checkbox"/> <b>CRI2</b><br><input type="checkbox"/> Yes |  |
| <input type="checkbox"/> <b>CRI2</b><br><input type="checkbox"/> Yes |  |
| <input type="checkbox"/> <b>CRI2</b><br><input type="checkbox"/> Yes |  |
| <input type="checkbox"/> <b>CRI2</b><br><input type="checkbox"/> Yes |  |
| <input type="checkbox"/> <b>CRI2</b><br><input type="checkbox"/> Yes |  |
| <input type="checkbox"/> <b>CRI2</b><br><input type="checkbox"/> Yes |  |
| <input type="checkbox"/> <b>CRI2</b><br><input type="checkbox"/> Yes |  |
| <input type="checkbox"/> <b>CRI2</b><br><input type="checkbox"/> Yes |  |
| <input type="checkbox"/> <b>CRI2</b><br><input type="checkbox"/> Yes |  |

**Steam Electric Questionnaire Code Tables**

| <b>Process Wastewaters</b>   |         |
|--|---------|
| <i>For Use in Tables and Questions throughout Parts A, B, C, D, and F.</i> |         |
| Air heater cleaning water  | AHCW    |
| Ash pile runoff  | APR     |
| Boiler blowdown  | BB      |
| Boiler fireside cleaning water   | BFCW    |
| Boiler tube cleaning water   | BTCW    |
| Bottom ash sluice  | BAS     |
| Carbon capture wastewater  | CCAPW   |
| Coal pile runoff   | CPR     |
| Combined ash sluice  | CAS     |
| Combustion turbine cleaning (combustion gas portion of turbine) water      | COMBCW  |
| Combustion turbine cleaning (compressor portion of the turbine) water      | COMPRCW |
| Combustion turbine evaporative coolers blowdown                            | TECB    |
| Cooling tower blowdown   | CTB     |
| FGD scrubber purge   | SCRBP   |
| FGD slurry blowdown  | FGDB    |
| Filter Backwash  | FLTBW   |
| Floor drain wastewater   | FDW     |
| Flue gas mercury control system wastewater                                 | FGMCW   |
| Fly ash sluice   | FAS     |
| General runoff   | GR      |
| Gypsum pile runoff   | GPR     |
| Gypsum wash water  | GYPWW   |
| Ion exchange wastewater  | IXW     |
| Landfill runoff - capped landfill  | LRC     |
| Landfill runoff - uncapped landfill  | LRUC    |
| Leachate   | LEACH   |
| Limestone pile runoff  | LPR     |
| Mill reject sluice   | MRS     |

| <b>Treated Wastewaters</b>  |             |
|---|-------------|
| <i>For Use as Effluents from Pond/Impoundment Systems and/or Wastewater Treatment Systems in Part D, Table D-4.</i>   |             |
| Effluent - 1  | EFF-1       |
| Effluent - 2  | EFF-2       |
| Effluent - 3  | EFF-3       |
| Effluent - 4  | EFF-4       |
| Effluent - 5  | EFF-5       |
| Effluent - 6  | EFF-6       |
| Filter backwash   | FltBW       |
| Sludge  | SLDG        |
| <i>For Use as Inflows to Pond/Impoundment Systems and/or Wastewater Treatment Systems in Part D, Table D-3, AND Recycled Waters Throughout Questionnaire.</i> |             |
| POND-1 Effluent   | POND-1-EFF  |
| POND-2 Effluent   | POND-2-EFF  |
| POND-3 Effluent   | POND-3-EFF  |
| POND-4 Effluent   | POND-4-EFF  |
| POND-5 Effluent   | POND-5-EFF  |
| POND-6 Effluent   | POND-6-EFF  |
| POND-7 Effluent   | POND-7-EFF  |
| POND-8 Effluent   | POND-8-EFF  |
| POND-9 Effluent   | POND-9-EFF  |
| POND-10 Effluent  | POND-10-EFF |
| POND-A Effluent   | POND-A-EFF  |
| POND-B Effluent   | POND-B-EFF  |
| POND-C Effluent   | POND-C-EFF  |
| WWT-1 Effluent  | WWT-1-EFF   |
| WWT-2 Effluent  | WWT-2-EFF   |
| WWT-3 Effluent  | WWT-3-EFF   |
| WWT-4 Effluent  | WWT-4-EFF   |
| WWT-5 Effluent  | WWT-5-EFF   |

**Steam Electric Questionnaire Code Tables**

| <b>Process Wastewaters</b>   |       |
|--|-------|
| <i>For Use in Tables and Questions throughout Parts A, B, C, D, and F.</i> |       |
| Once -through cooling water  | CW    |
| Reverse osmosis reject water   | RORW  |
| SCR catalyst regeneration wastewater                                       | SCRRW |
| SCR catalyst washing wastewater  | SCRWW |
| Soot blowing wash water  | SOOTW |
| Steam turbine cleaning water   | STCW  |
| Yard drain wastewater  | YARDW |

| <b>Treated Wastewaters</b>   |           |
|--|-----------|
| <i>For Use as Influent to Pond/Impoundment Systems and/or Wastewater Treatment Systems in Part D, Table D-3, AND Recycled Waters Throughout Questionnaire.</i> |           |
| WWT-6 Effluent   | WWT-6-EFF |
| WWT-A Effluent   | WWT-A-EFF |
| WWT-B Effluent   | WWT-B-EFF |
| WWT-C Effluent   | WWT-C-EFF |

**Steam Electric Questionnaire Code Tables**

| <b>Wastewater Treatment Units</b>                                |           |
|--|-----------|
| <i>For Use in Tables and Questions Throughout Parts D and F.</i> |           |
| Adsorptive media   | ADSORB    |
| Aerobic Biological Reactor                                       | AERBIO    |
| Anaerobic Biological Reactor                                     | ANBIO     |
| Aerobic/Anaerobic Biological Reactor                             | AER/ANBIO |
| Chemical Precipitation Reaction Tank 1 - 1                       | CP-1-1    |
| Chemical Precipitation Reaction Tank 1 - 2                       | CP-1-2    |
| Chemical Precipitation Reaction Tank 2 - 1                       | CP-2-1    |
| Chemical Precipitation Reaction Tank 2 - 2                       | CP-2-2    |
| Chemical Precipitation Reaction Tank 3 - 1                       | CP-3-1    |
| Chemical Precipitation Reaction Tank 3 - 2                       | CP-3-2    |
| Clarification, Primary - 1                                       | CL-P-1    |
| Clarification, Primary - 2                                       | CL-P-2    |
| Clarification, Secondary - 1                                     | CL-S-1    |
| Clarification, Secondary - 2                                     | CL-S-2    |
| Clarification, Tertiary - 1                                      | CL-T-1    |
| Clarification, Tertiary - 2                                      | CL-T-2    |
| Constructed wetland - Cell 1                                     | CWL -1    |
| Constructed wetland - Cell 2                                     | CWL -2    |
| Constructed wetland - Cell 3                                     | CWL -3    |
| Constructed wetland - Cell 4                                     | CWL -4    |
| Constructed wetland - Cell 5                                     | CWL -5    |
| Constructed wetland - Cell 6                                     | CWL -6    |
| Constructed wetland system                                       | CWTS      |
| Equalization, Primary  | EQ-P      |
| Equalization, Secondary  | EQ-S      |
| Filter, Microfiltration - 1                                      | FLT-M-1   |
| Filter, Microfiltration - 2                                      | FLT-M-2   |

| <b>Destinations</b>   |            |
|---|------------|
| <i>For Use in Tables and Questions Throughout Parts A, C, D, and F.</i> |            |
| Burned on site  | BURN       |
| Deep-well injection   | DWELL      |
| Discharge to POTW   | POTW       |
| Discharge to PrOTW  | PrOTW      |
| Discharge to surface water  | SW         |
| Evaporation   | EVAP       |
| Hauled off site for reuse (removal fee)                                 | HAULR - RF |
| Hauled off site for reuse (given away)                                  | HAULR - GA |
| Hauled off site for reuse (marketed and sold)                           | SOLD       |
| Hauled off site for disposal  | HAUL       |
| Mixed with fly ash for disposal   | MFA        |
| On-site landfill (as reported in Table A-6)                             | LANDF      |
| POND-1  | POND-1     |
| POND-2  | POND-2     |
| POND-3  | POND-3     |
| POND-4  | POND-4     |
| POND-5  | POND-5     |
| POND-6  | POND-6     |
| POND-7  | POND-7     |
| POND-8  | POND-8     |
| POND-9  | POND-9     |
| POND-10   | POND-10    |
| POND-A  | POND-A     |
| POND-B  | POND-B     |
| POND-C  | POND-C     |
| WWT-1   | WWT-1      |
| WWT-2   | WWT-2      |

## Steam Electric Questionnaire Code Tables

| Wastewater Treatment Units                                       |         |
|--|---------|
| <i>For Use in Tables and Questions Throughout Parts D and F.</i> |         |
| Filter, Microfiltration - 3                                      | FLT-M-3 |
| Filter, Microfiltration - 4                                      | FLT-M-4 |
| Filter, Sand/Gravity - 1   | FLT-S-1 |
| Filter, Sand/Gravity - 2   | FLT-S-2 |
| Filter, Sand/Gravity - 3   | FLT-S-3 |
| Filter, Sand/Gravity - 4   | FLT-S-4 |
| Filter, Ultrafiltration - 1                                      | FLT-U-1 |
| Filter, Ultrafiltration - 2                                      | FLT-U-2 |
| Filter, Ultrafiltration - 3                                      | FLT-U-3 |
| Filter, Ultrafiltration - 4                                      | FLT-U-4 |
| Filter press - 1   | FP-1    |
| Filter press - 2   | FP-2    |
| Holding tank   | HT      |
| Ion exchange   | IX      |
| Natural wetlands   | NW      |
| pH adjustment - 1  | PH-1    |
| pH adjustment - 2  | PH-2    |
| pH adjustment - 3  | PH-3    |
| Reverse osmosis  | ROS     |
| Pond Unit - 1  | SPD-1   |
| Pond Unit - 2  | SPD-2   |
| Pond Unit - 3  | SPD-3   |
| Pond Unit - 4  | SPD-4   |
| Pond Unit - 5  | SPD-5   |
| Pond Unit - 6  | SPD-6   |
| Pond Unit - 7  | SPD-7   |
| Pond Unit - 8  | SPD-8   |
| Pond Unit - 9  | SPD-9   |

| Destinations  |               |
|---|---------------|
| <i>For Use in Tables and Questions Throughout Parts A, C, D, and F.</i> |               |
| WWT-3   | WWT-3         |
| WWT-4   | WWT-4         |
| WWT-5   | WWT-5         |
| WWT-6   | WWT-6         |
| WWT-A   | WWT-A         |
| WWT-B   | WWT-B         |
| WWT-C   | WWT-C         |
| Reuse as boiler water   | RECYC - BW    |
| Reuse as bottom ash sluice  | RECYC - BAS   |
| Reuse as combined ash sluice  | RECYC - CAS   |
| Reuse as FGD slurry preparation water                                   | RECYC - FGDP  |
| Reuse as FGD absorber makeup  | RECYC - FGDAB |
| Reuse as fly ash sluice   | RECYC - FAS   |
| Reuse as mill reject sluice   | RECYC - MRS   |
| Reuse in cooling towers   | RECYC - CW    |



## Steam Electric Questionnaire Code Tables

| Wastewater Treatment Units                                       |        |
|--|--------|
| <i>For Use in Tables and Questions Throughout Parts D and F.</i> |        |
| Pond Unit - 10   | SPD-10 |
| Pond Unit - 11   | SPD-11 |
| Pond Unit - 12   | SPD-12 |
| Pond Unit - 13   | SPD-13 |
| Pond Unit - 14   | SPD-14 |
| Settling tank - 1  | ST-1   |
| Settling tank - 2  | ST-2   |
| Settling tank - 3  | ST-3   |
| Settling tank - 4  | ST-4   |
| Settling tank - 5  | ST-5   |
| Thickener - 1  | TH-1   |
| Thickener - 2  | TH-2   |
| Vacuum drum filter - 1   | VF-1   |
| Vacuum drum filter - 2   | VF-2   |
| Vacuum filter belt - 1   | VFB-1  |
| Vacuum filter belt - 2   | VFB-2  |

| Solids Handling  |        |
|--|--------|
| <i>For Use as Planned Solids Handling for the FGD Slurry Blowdown in Part B Table B-2.</i> |        |
| Centrifuge - 1   | CENT-1 |
| Centrifuge - 2   | CENT-2 |
| Centrifuge - 3   | CENT-3 |
| Centrifuge - 4   | CENT-4 |
| Hydrocyclones - 1  | HYC-1  |
| Hydrocyclones - 2  | HYC-2  |
| Hydrocyclones - 3  | HYC-3  |
| Hydrocyclones - 4  | HYC-4  |
| Filter press - 1   | FP-1   |
| Filter press - 2   | FP-2   |
| Thickener - 1  | TH-1   |
| Thickener - 2  | TH-2   |
| Vacuum drum filter - 1   | VF-1   |
| Vacuum drum filter - 2   | VF-2   |
| Vacuum filter belt - 1   | VFB-1  |
| Vacuum filter belt - 2   | VFB-2  |

Plant ID:

Plant Name:

Pond/Impoundment System ID or Wastewater Treatment System ID:

**Part: D****Section Title:** 3.1. Wastewater Treatment Diagram

**Instructions:** Complete Section 3.1 (Question D3-1) for each *pond/impoundment system* or *wastewater treatment system* listed in Table D-2, including planned systems, systems under construction/installation, or planned to be under construction by December 31, 2020. Enter the pond/impoundment system ID or wastewater treatment system ID in the column provided above (use the pond/impoundment system ID or wastewater treatment system ID assigned to the system).

Make a copy of Section 3.1 for each pond/impoundment system or wastewater treatment system identified in the list above using the "Copy Section 3.1" button below.

**CBI?** Yes

**D3-1.** Attach a block diagram that shows the pond/impoundment system or wastewater treatment system or other facility that currently enter or are planned to enter the pond/impoundment system or wastewater treatment system. Show the ultimate destinations of the pond/impoundment system or wastewater treatment system effluent(s). Sources are provided in the checklist below. The diagram should have a similar level of detail as EPA's example diagram, EPA\_D-2.

**NOTE:** You may use an existing diagram, such as a water balance diagram included in the plant permit application, to provide the additional required information on the diagram by hand.

Provide as many diagrams as necessary to convey the information requested in the checklist below. Each diagram should be placed in the upper right corner; the first block diagram should be numbered D-1, the second D-2, etc. Include the pond/impoundment system ID or wastewater treatment system ID in the upper right hand corner of the diagram.

 Diagram attached.

**Block Diagram Checklist**

Mark the boxes below to verify that you have completed each checklist item...

- Include the block diagram number, plant name, plant ID, and pond/impoundment system ID or on the diagram.
- Include each pond/impoundment or wastewater treatment unit operation. Show all influent and label all influent and effluent streams from the pond/impoundment system or wastewater treatment units on the "Code Tables" tab provided at the end of this workbook. Note that the "Code Tables" tab includes wastewater treatment units that are operated in series and/or in parallel (e.g., in EPA\_D-1, Ch 1-1 and Chemical Precipitation Reaction Tank 2-1 are in series). Effluent streams may include
- If applicable, use EPA-assigned numbers from Part A or B (e.g., FGD-1) to label *process operations*. If a process operation does not have an EPA-assigned number (e.g., boiler, air preheater), use the plant-designated name. If sources or destinations are not shown on the diagram (i.e., the stream is entering from a local source or exiting to a local destination), describe the source or destination and add the block diagram number, when appropriate, where it can be seen. Use codes from the code tables on the "Code Tables" tab provided at the end of this workbook.
- Indicate where chemical addition occurs (i.e., into or between which wastewater treatment unit). For each wastewater treatment unit, indicate and note on the diagram where within or near the pond/impoundment (e.g., within the pond/impoundment near the process wastewater influent point, within the pond/impoundment near the effluent/discharge canal). The chemicals indicated should correspond to the chemicals list on D-9.
- Identify the final, general destination of the *treated* process wastewater and waste streams (e.g., effluent to POTW or surface waters; solid wastes to on- or off-site destinations). Use codes from the "Code Tables" tab provided at the end of this workbook, when applicable.
- Indicate, as appropriate, where treated process wastewater is *reused* or *recycled* within the pond/impoundment (e.g., as fly ash sludge).
- Include the average annual (2009) flow rates for influent and effluent streams from the wastewater treatment system diagram (in gpm or gpd). For planned pond/impoundment systems and wastewater treatment units, provide flow rates for the system. Note that these should be the same flow rates that are entered into Table D-1. If the number of days of operation for 2009 is not known, the total annual flow may be divided by 365 on the Comments page. If the process wastewater stream is intermittent, provide amount and frequency (e.g., "100 gpm, 4 hpd, 365 dpy" or "1000 gpm, 4 hpd, 365 dpy"). For sludges, provide amount in tpd.

- Include NPDES permit outfall numbers, if applicable.

If you believe that the diagram should be treated as confidential, stamp it "Confidential" or write "Con  
any diagram is not marked "Confidential", it will be considered nonconfidential under 40 CFR Part 2,

**Review:**

If any of the statements above were not checked, revise the block diagram(s) and ensure all si

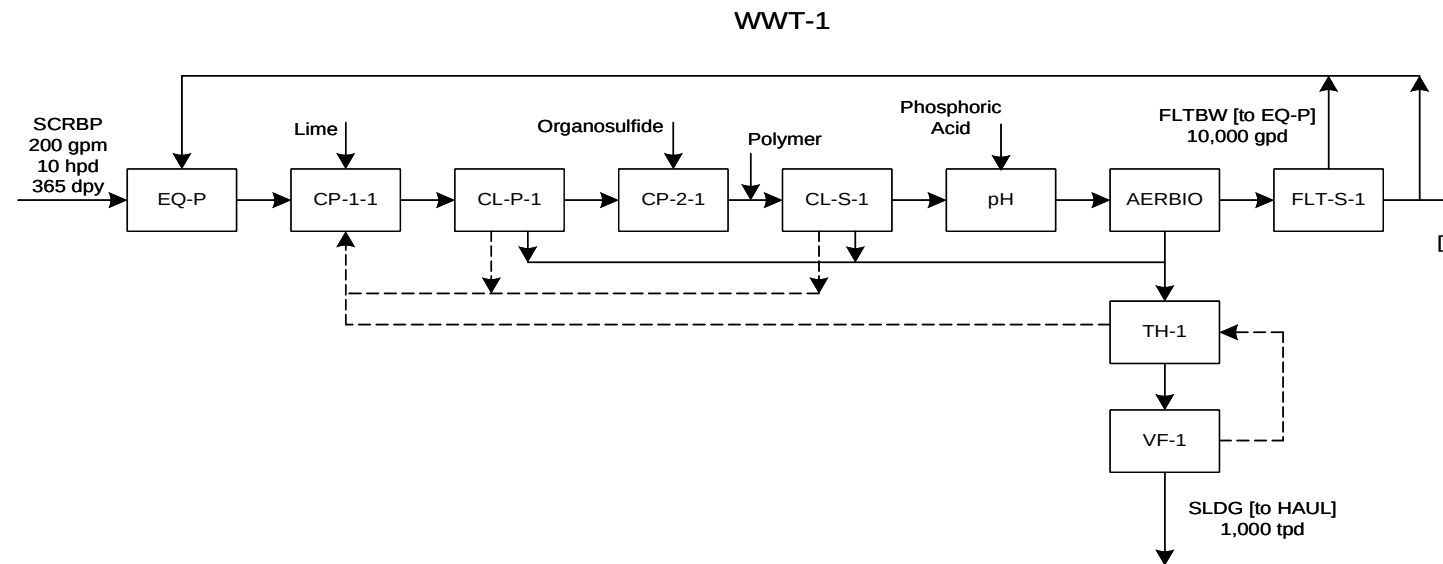

**Example EPA\_D-1. Block Diagram for FGD Wastewater Treatment 5**

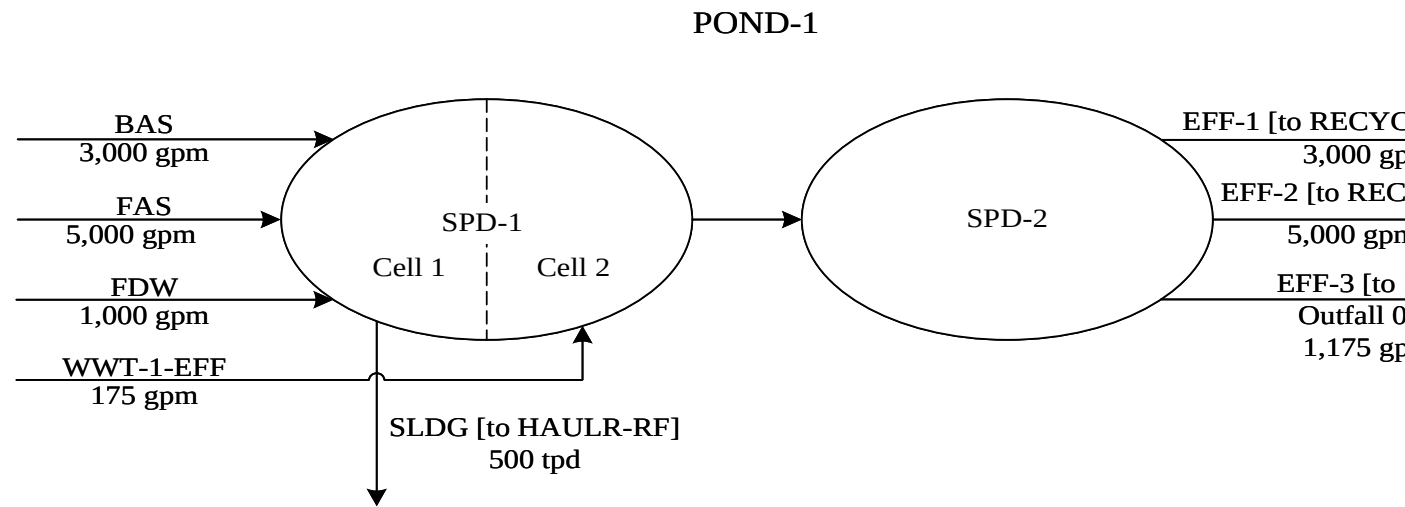

**Example EPA\_D-2. Block Diagram for Ash Pond System**

**NOTE: The codes used in these diagrams correspond the code tables on the "Code Tables" workbook.**

and Other Wastewater Treatment Operations

Insert Plant ID

Insert Plant Name

Insert System ID

system identified in Table D-1 and  
or construction/installation by  
the yellow highlighted space  
in Table D-1 and Table D-2).

ntified in Table D-1 and Table D-2

operations, the process  
or treatment system, and the  
specific instructions for the diagram  
ple diagrams, EPA\_D-1 and

**nt's NPDES Form 2C, and mark**

Number each block diagram in the  
plant name, plant ID, and  
re diagram.

and Other Wastewater Treatment Operations

Wastewater treatment system ID

Effluent streams from the units  
Wastewater treatment system using the code  
Tables" tab provides codes for  
Chemical Precipitation Reaction Tank  
Process wastewater and sludges.

Operations. If a process operation does  
not exist for the process operation. When  
operation is not shown on the diagram,  
reference the stream's previous location  
in this workbook.

Tables). For pond/impoundment  
operations, the chemical is added  
to the pond/impoundment near the effluent, in  
accordance with Tables Table D-5 and Table

For example, treated process wastewater  
is added to the pond/impoundment in  
accordance with Tables Table D-5 and Table

For example, reuse of settling

Wastewater treatment system on the  
design systems, provide the design flow  
rate in Table D-3 in Question D2-2. If the actual  
flow rate is not known, provide the flow rate  
for 5 days and a comment added to  
the table; for example "100 gal,

idential" or "CBI" across the top. If Subpart B.

tatements have been checked.

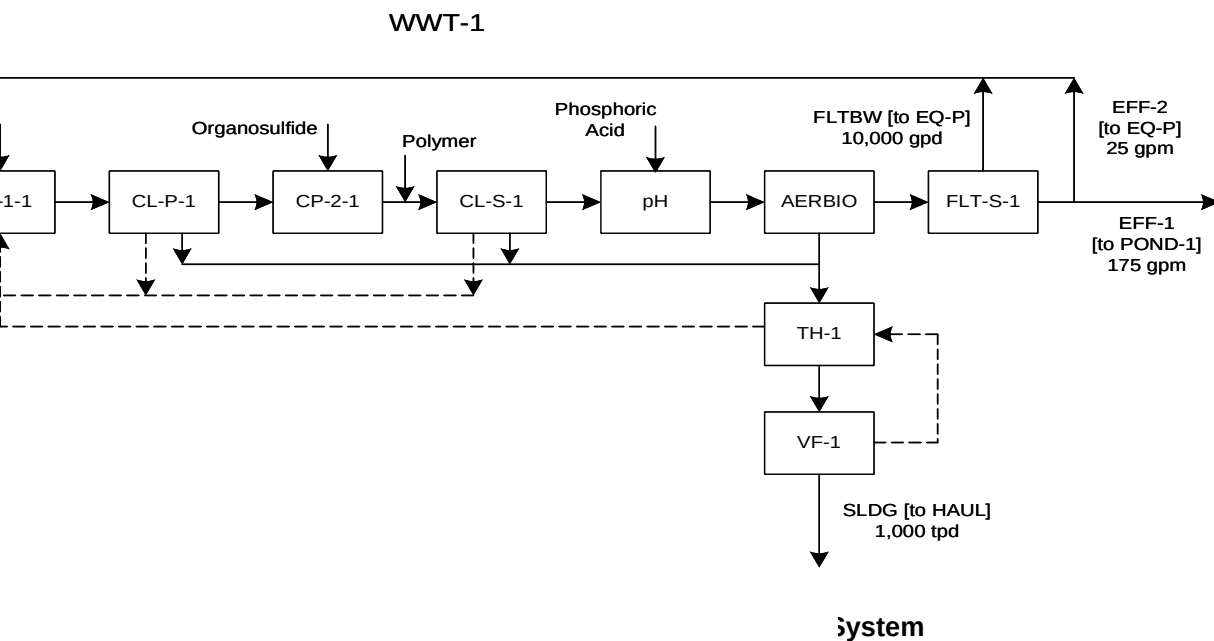



POND-1

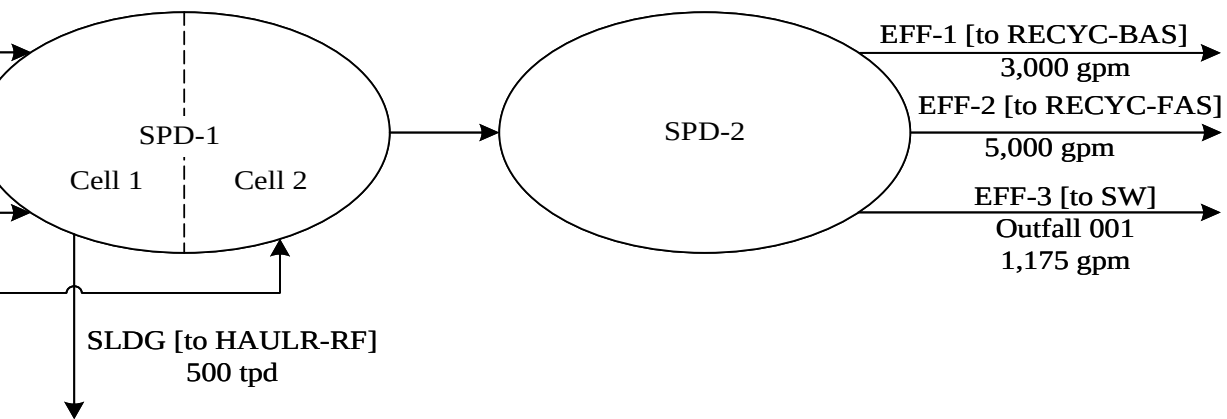

' tab provided at the end of this

Plant ID: Insert Plant ID  
 Plant Name: Insert Plant Name

Pond/Impoundment System ID or Wastewater Treatment System ID: Insert System ID

**Part: D**

**Section Title: 3.2. Wastewater Treatment Wastewater Flows**

**Instructions:** Complete Section 3.2 (Question D3-2 and D3-3) for each *pond/impoundment system* or *wastewater treatment system* identified in Table D-1 and Table D-2, including planned systems, systems under construction/installation, or planned to be under construction/installation by December 31, 2020. Enter the pond/impoundment system ID or wastewater treatment system ID in the yellow highlighted space provided above (use the pond/impoundment system ID or wastewater treatment system ID assigned in Table D-1 and Table D-2).

Make a copy of Section 3.2 for each pond/impoundment system or wastewater treatment system identified in Table D-1 and Table D-2 using the "Copy Section 3.2" button below.

**CBI?**  
 Ye

**D3-2.** Complete a row in Table D-3 for each *process wastewater* stream or *treated* wastewater stream that enters this pond/impoundment system or wastewater treatment system. For planned pond/impoundment systems and wastewater treatment systems, provide the design flow rates for the system. Use the process and treated wastewater terms provided in the drop down menus. Note that these terms originated from code tables on the "Code Tables" tab provided at the end of this workbook.

Note: The examples in Tables D-3 and D-4 are derived from the EPA examples diagrams, EPA\_D-1 and EPA\_D-2, provided at the bottom of Part D Section 3.1.

**Table D-3. Pond/Impoundment System or Wastewater Treatment System Influent Flows in 2009**

| Process or Treated Wastewater  | Average Annual (2009) Wastewater Flow Rate |        |         | Wastewater Treatment Unit ID |
|--------------------------------|--|--------|---------|------------------------------|
| <b>Example (from EPA_D-1):</b> |  |        |         |                              |
|                                | 200 gpm                                    | 10 hpd | 365 dpy |                              |
| Other:                         | OR   | gpd    | dpy     | Other:                       |
| <b>Example (from EPA_D-2):</b> |  |        |         |                              |
|                                | 175 gpm                                    | 24 hpd | 365 dpy |                              |
| Other:                         | OR   | gpd    | dpy     | Other:                       |
|                                | gpm  | hpd    | dpy     |                              |
| Other:                         | OR   | gpd    | dpy     | Other:                       |
|                                | gpm  | hpd    | dpy     |                              |
| Other:                         | OR   | gpd    | dpy     | Other:                       |
|                                | gpm  | hpd    | dpy     |                              |
| Other:                         | OR   | gpd    | dpy     | Other:                       |
|                                | gpm  | hpd    | dpy     |                              |
| Other:                         | OR   | gpd    | dpy     | Other:                       |
|                                | gpm  | hpd    | dpy     |                              |
| Other:                         | OR   | gpd    | dpy     | Other:                       |
|                                | gpm  | hpd    | dpy     |                              |
| Other:                         | OR   | gpd    | dpy     | Other:                       |

|        |    |     |     |     |        |
|--------|----|-----|-----|-----|--------|
|        |    | gpm | hpd | dpy |        |
| Other: | OR |     | gpd | dpy | Other: |
|        |    | gpm | hpd | dpy |        |
| Other: | OR |     | gpd | dpy | Other: |
|        |    | gpm | hpd | dpy |        |
| Other: | OR |     | gpd | dpy | Other: |
|        |    | gpm | hpd | dpy |        |
| Other: | OR |     | gpd | dpy | Other: |
|        |    | gpm | hpd | dpy |        |
| Other: | OR |     | gpd | dpy | Other: |
|        |    | gpm | hpd | dpy |        |
| Other: | OR |     | gpd | dpy | Other: |
|        |    | gpm | hpd | dpy |        |
| Other: | OR |     | gpd | dpy | Other: |
|        |    | gpm | hpd | dpy |        |
| Other: | OR |     | gpd | dpy | Other: |
|        |    | gpm | hpd | dpy |        |
| Other: | OR |     | gpd | dpy | Other: |
|        |    | gpm | hpd | dpy |        |
| Other: | OR |     | gpd | dpy | Other: |
|        |    | gpm | hpd | dpy |        |
| Other: | OR |     | gpd | dpy | Other: |
|        |    | gpm | hpd | dpy |        |
| Other: | OR |     | gpd | dpy | Other: |
|        |    | gpm | hpd | dpy |        |
| Other: | OR |     | gpd | dpy | Other: |
|        |    | gpm | hpd | dpy |        |
| Other: | OR |     | gpd | dpy | Other: |
|        |    | gpm | hpd | dpy |        |
| Other: | OR |     | gpd | dpy | Other: |
|        |    | gpm | hpd | dpy |        |
| Other: | OR |     | gpd | dpy | Other: |
|        |    | gpm | hpd | dpy |        |
| Other: | OR |     | gpd | dpy | Other: |
|        |    | gpm | hpd | dpy |        |
| Other: | OR |     | gpd | dpy | Other: |
|        |    | gpm | hpd | dpy |        |
| Other: | OR |     | gpd | dpy | Other: |

CBI?  
 Yes

**D3-3.** Complete a row in Table D-4 for each treated wastewater stream or *sludge* stream that exits this pond/impoundment system or wastewater treatment system (i.e., streams that are *discharged, recycled, or* disposed). For planned pond/impoundment systems and wastewater treatment systems, provide the design flow rates for the system. Use the treated wastewater, wastewater treatment unit, and destination terms provided in the drop down menus. Note that these terms originated from code tables on the "Code Tables" tab provided at the end of this workbook.

\*Provide the NPDES permit outfall number of the effluent in the last column of the table, if applicable.

**Table D-4. Pond/Impoundment System or Wastewater Treatment System Effluent Flows in 2009**

| Treated Wastewater             | Average Annual (2009) Wastewater Flow Rate |            |         | Solids and Sludge   |  | Final Destination            |             |                              |     |
|--------------------------------|--|------------|---------|---------------------|--|------------------------------|-------------|------------------------------|-----|
|                                |  |            |         | Amount (tpd or gpm) | % Moisture   | Wastewater Treatment Unit ID | Destination | NPDES Permit Outfall Number* |     |
| <b>Example (from EPA_D-1):</b> |  |            |         |                     | <input type="radio"/> tpd<br><input type="radio"/> gpm |                              |             |                              |     |
|                                | 175 gpm                                    | 24 hpd     | 365 dpy | NA                  | NA   |                              |             |                              | NA  |
| Other:                         | OR   | NA         | NA      | NA                  |  | Other:                       | Other:      |                              |     |
| <b>Example (from EPA_D-1):</b> |  |            |         |                     | <input type="radio"/> tpd<br><input type="radio"/> gp  |                              |             |                              |     |
|                                | NA   | NA         | NA      | NA                  | NA   |                              |             |                              | NA  |
| Other:                         | OR   | 10,000 gpd | 365 dpy |                     |  | Other:                       | Other:      |                              |     |
| <b>Example (from EPA_D-2):</b> |  |            |         |                     | <input type="radio"/> tpc<br><input type="radio"/> gpc |                              |             |                              |     |
|                                | NA   | NA         | NA      | 500                 | 30   |                              |             |                              | NA  |
| Other:                         | OR   | NA         | NA      |                     |  | Other:                       | Other:      |                              |     |
| <b>Example (from EPA_D-2):</b> |  |            |         |                     | <input type="radio"/> tpc<br><input type="radio"/> gpc |                              |             |                              |     |
|                                | 5,000 gpm                                  | 24 hpd     | 365 dpy | NA                  | NA   |                              |             |                              | NA  |
| Other:                         | OR   | NA         | NA      |                     |  | Other:                       | Other:      |                              |     |
| <b>Example (from EPA_D-2):</b> |  |            |         |                     | <input type="radio"/> tpc<br><input type="radio"/> gpc |                              |             |                              |     |
|                                | 1,175 gpm                                  | 24 hpd     | 365 dpy | NA                  | NA   |                              |             |                              | 001 |
| Other:                         | OR   |            |         |                     |  | Other:                       | Other:      |                              |     |
|                                |  |            |         |                     | <input type="radio"/> tpd<br><input type="radio"/> gp  |                              |             |                              |     |
| Other:                         | OR   |            |         |                     |  | Other:                       | Other:      |                              |     |
|                                |  |            |         |                     | <input type="radio"/> tpc<br><input type="radio"/> gpc |                              |             |                              |     |
| Other:                         | OR   |            |         |                     |  | Other:                       | Other:      |                              |     |
|                                |  |            |         |                     | <input type="radio"/> tpc<br><input type="radio"/> gpc |                              |             |                              |     |
| Other:                         | OR   |            |         |                     |  | Other:                       | Other:      |                              |     |
|                                |  |            |         |                     | <input type="radio"/> tpc<br><input type="radio"/> gpc |                              |             |                              |     |
| Other:                         | OR   |            |         |                     |  | Other:                       | Other:      |                              |     |
|                                |  |            |         |                     | <input type="radio"/> tpc<br><input type="radio"/> gpc |                              |             |                              |     |
| Other:                         | OR   |            |         |                     |  | Other:                       | Other:      |                              |     |
|                                |  |            |         |                     | <input type="radio"/> tpc<br><input type="radio"/> gpc |                              |             |                              |     |
| Other:                         | OR   |            |         |                     |  | Other:                       | Other:      |                              |     |

|        |    |     |     |     |  |                           |        |        |  |
|--------|----|-----|-----|-----|--|---------------------------|--------|--------|--|
|        |    | gpm | hpd | dpy |  | <input type="radio"/> tnc |        |        |  |
| Other: | OR |     | gpd | dpy |  | <input type="radio"/> gpr | Other: | Other: |  |
|        |    | gpm | hpd | dpy |  | <input type="radio"/> tnc |        |        |  |
| Other: | OR |     | gpd | dpy |  | <input type="radio"/> gpr | Other: | Other: |  |
|        |    | gpm | hpd | dpy |  | <input type="radio"/> tnc |        |        |  |
| Other: | OR |     | gpd | dpy |  | <input type="radio"/> gpr | Other: | Other: |  |
|        |    | gpm | hpd | dpy |  | <input type="radio"/> tnc |        |        |  |
| Other: | OR |     | gpd | dpy |  | <input type="radio"/> gpr | Other: | Other: |  |
|        |    | gpm | hpd | dpy |  | <input type="radio"/> tnc |        |        |  |
| Other: | OR |     | gpd | dpy |  | <input type="radio"/> gpr | Other: | Other: |  |
|        |    | gpm | hpd | dpy |  | <input type="radio"/> tnc |        |        |  |
| Other: | OR |     | gpd | dpy |  | <input type="radio"/> gpr | Other: | Other: |  |
|        |    | gpm | hpd | dpy |  | <input type="radio"/> tnc |        |        |  |
| Other: | OR |     | gpd | dpy |  | <input type="radio"/> gpr | Other: | Other: |  |
|        |    | gpm | hpd | dpy |  | <input type="radio"/> tnc |        |        |  |
| Other: | OR |     | gpd | dpy |  | <input type="radio"/> gpr | Other: | Other: |  |
|        |    | gpm | hpd | dpy |  | <input type="radio"/> tnc |        |        |  |
| Other: | OR |     | gpd | dpy |  | <input type="radio"/> gpr | Other: | Other: |  |
|        |    | gpm | hpd | dpy |  | <input type="radio"/> tnc |        |        |  |
| Other: | OR |     | gpd | dpy |  | <input type="radio"/> gpr | Other: | Other: |  |
|        |    | gpm | hpd | dpy |  | <input type="radio"/> tnc |        |        |  |
| Other: | OR |     | gpd | dpy |  | <input type="radio"/> gpr | Other: | Other: |  |
|        |    | gpm | hpd | dpy |  | <input type="radio"/> tnc |        |        |  |
| Other: | OR |     | gpd | dpy |  | <input type="radio"/> gpr | Other: | Other: |  |
|        |    | gpm | hpd | dpy |  | <input type="radio"/> tnc |        |        |  |
| Other: | OR |     | gpd | dpy |  | <input type="radio"/> gpr | Other: | Other: |  |
|        |    | gpm | hpd | dpy |  | <input type="radio"/> tnc |        |        |  |
| Other: | OR |     | gpd | dpy |  | <input type="radio"/> gpr | Other: | Other: |  |
|        |    | gpm | hpd | dpy |  | <input type="radio"/> tnc |        |        |  |
| Other: | OR |     | gpd | dpy |  | <input type="radio"/> gpr | Other: | Other: |  |
|        |    | gpm | hpd | dpy |  | <input type="radio"/> tnc |        |        |  |
| Other: | OR |     | gpd | dpy |  | <input type="radio"/> gpr | Other: | Other: |  |
|        |    | gpm | hpd | dpy |  | <input type="radio"/> tnc |        |        |  |
| Other: | OR |     | gpd | dpy |  | <input type="radio"/> gpr | Other: | Other: |  |
|        |    | gpm | hpd | dpy |  | <input type="radio"/> tnc |        |        |  |
| Other: | OR |     | gpd | dpy |  | <input type="radio"/> gpr | Other: | Other: |  |

Plant ID: Insert Plant ID  
 Plant Name: Insert Plant Name  
 Pond/Impoundment Unit ID: Insert Unit ID

**Part: D**  
**Section Title:** 4.1. Active/Inactive/Open and Planned Pond/Impoundment Unit Information

**Instructions:** Complete Section 4.1 (Questions D4-1 through D4-12) for each active/inactive/open *pond/impoundment* unit used OR planned to be used (or constructed/installed), including those located on non-adjointing property, by December 31, 2020 for the storage, treatment, and/or disposal of process wastewater, *residues*, or by-products (or *sludges* or water streams containing the residues or by-products) from the combustion of coal, petroleum coke, or oil, including but not limited to fly ash, bottom ash, boiler slag, or flue gas emission control residues. Use the pond/impoundment unit IDs assigned in Table A-4.

Make a copy of Section 4.1 for each active/inactive/open and planned pond/impoundment units used (or planned to be used) for the storage, treatment, and/or disposal of process wastewater, residues, or by-products (or sludges or water streams containing the residues or by-products) from the combustion of coal, petroleum coke, or oil, including but not limited to fly ash, bottom ash, boiler slag, or flue gas emission control residues using the "Copy Section 4.1" button below.

NOTE: If a pond/impoundment unit is part of a broader wastewater treatment system containing non-pond wastewater treatment units (e.g., a pond/impoundment unit in a biological wastewater treatment system), complete questions in this section for the pond/impoundment unit.

**CBI?**  
 **Ye**

**D4-1.** Do you use OR plan to use (or begin construction/installation of) by December 31, 2020, any active/inactive/open ponds/impoundments, including those located on non-adjointing property, for the storage, treatment, and/or disposal of process wastewater, residues, or by-products (or sludges or water streams containing the residues or by-products) from the combustion of coal, petroleum coke, or oil, including but not limited to fly ash, bottom ash, boiler slag, or flue gas emission control residues?

**Yes** (Continue)  
 **No** ([Skip to Section 4.2](#))

**CBI?**  
 **Ye**

**D4-2.** Provide the residence time of the process wastewater in the pond/impoundment unit, the life of the pond/impoundment unit (based on the current estimation), and the number of cells in the pond/impoundment unit.

Residence time, hours (as currently operated)  
 Life of pond/impoundment unit, years (based on current estimation)  
 Number of cells in pond/impoundment unit

**CBI?**  
 **Ye**

**D4-3.** Complete Table D-5. Provide the pond/impoundment unit's volume, surface area, bottom and top elevation, freeboard height, maximum height of berms and dams above the surrounding grade, and the total quantity of solids placed in the pond/impoundment when it was originally built or planned/designed, at its current status, and at its expected end of life. Additionally, provide the expected year of closure/retirement in the "Expected End of Life" column. Volume should reflect the free water volume, including the stored solids. For planned pond/impoundment units, enter "NA" in all fields in the "Current" column. Figure D-1 presents an illustration of pond/impoundment dimensions.

Note: Respondents are not required to take new measurements to provide this data; however, best available information should be used to answer Table D-5.

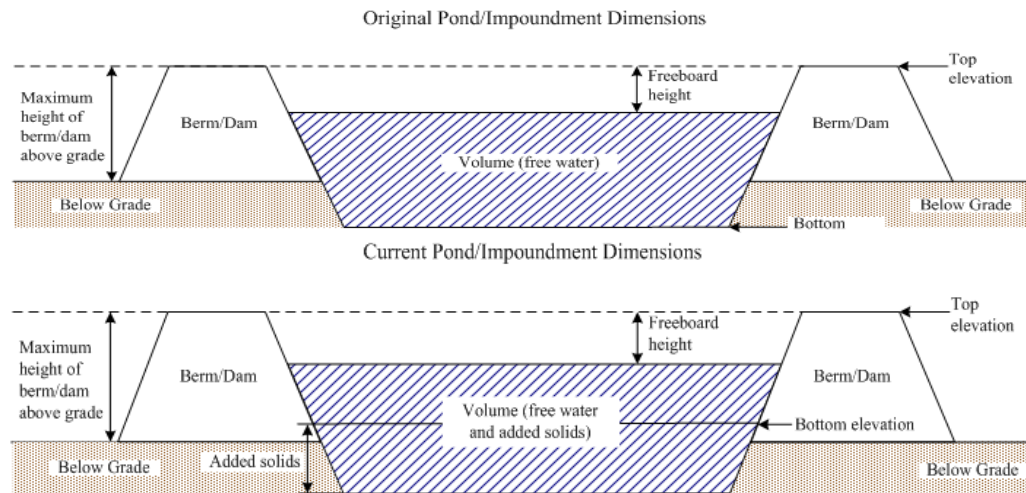

Figure D-1. Pond/Impoundment Dimensions

Table D-5. Active/Inactive/Open and Planned Pond/Impoundment Information

|   | Originally Built or Planned/Designed | Current | Expected End of Life |
|---|--------------------------------------|---------|----------------------|
| Volume, ft <sup>3</sup>                           |                                      |         |                      |
| Surface area, ft <sup>2</sup>                     |                                      |         |                      |
| Bottom elevation, ft                              |                                      |         |                      |
| Top elevation, ft                                 |                                      |         |                      |
| Freeboard height, ft                              |                                      |         |                      |
| Maximum height of berms/dams above grade, ft      |                                      |         |                      |
| Total solids placed in the pond/impoundment, tons |                                      |         |                      |
| Expected year of closure/retirement               |                                      |         |                      |

CBI?  
 Yes

D4-4. Does the pond/impoundment unit have a liner?

- Yes (Complete Table D-6)
- No (Skip to Question D4-5)
- NA (Pond/Impoundment is planned to be constructed. Information is currently unavailable. Skip to Question D4-10).

Table D-6. Pond/Impoundment Unit Liner

| Liner Layer Number (number from inner to outer layer) | Type of Liner  | Thickness of Liner Layer (cm) | Permeability of Liner Layer (cm/sec) |
|---|--|-------------------------------|--------------------------------------|
|   | <input type="radio"/> Compacted clay<br><input type="radio"/> Geosynthetic c<br><input type="radio"/> High density polye<br><input type="radio"/> Other (provide |                               |                                      |
|   |  |                               |                                      |
|   | <input type="radio"/> Compacted clay<br><input type="radio"/> Geosynthetic c<br><input type="radio"/> High density polye<br><input type="radio"/> Other (provide |                               |                                      |
|   |  |                               |                                      |
|   | <input type="radio"/> Compacted clay<br><input type="radio"/> Geosynthetic c<br><input type="radio"/> High density polye<br><input type="radio"/> Other (provide |                               |                                      |
|   |  |                               |                                      |
|   | <input type="radio"/> Compacted clay<br><input type="radio"/> Geosynthetic c<br><input type="radio"/> High density polye<br><input type="radio"/> Other (provide |                               |                                      |
|   |  |                               |                                      |

CBI?  
 Yes

D4-5. Has the pond/impoundment unit ever been dredged?

- Yes (Provide following
  - Year of last dredging
  - Frequency of dredging that year, dpy
  - Amount of material removed that year, tons
  - Number of times dredged in the last five years
  - Number of days dredged in the last five years
  - Amount of material removed in the last five years, tons
- No (Skip to Question D4-7)
- NA (Pond/Impoundment is planned to be constructed. Skip to Question D4-10)



CBI?  
 Yes

D4-6. Indicate where the dredged solids are transferred or are planned to be transferred.

- Dredged solids used in embankment
- Dredged solids transferred to another pond
- Dredged solids marketed/sold
- Other (Explain )

CBI?  
 Yes

D4-7. Has the pond/impoundment unit been expanded since the date it was built?

- Yes (Continue)
- No (Skip to Question D4-10)
- NA (Pond/impoundment is planned to be constructed. Skip to Question D4-10)

CBI?  
 Yes

D4-8. Identify the type of expansion.

- Lateral expansion
- Vertical expansion
- Both lateral and vertical expansion

CBI?  
 Yes

D4-9. Describe the expansion(s) to the pond/impoundment unit, including the starting and ending dimensions and the total capital and O&M costs associated with the expansion(s).

**Note: Total O&M costs should include labor, materials, energy, hazardous and nonhazardous waste disposal, and any other costs available. Total capital costs should include purchased equipment, installation, buildings, site preparation, land, engineering costs, construction expenses, and any other costs available.**

CBI?  
 Yes

D4-10. Indicate the *pollutants* targeted for removal by this pond/impoundment unit using techniques other than solely settling (e.g., adding chemicals to remove certain metals). [Check all boxes that apply.]

- Metals (specify )
- TSS
- Nitrogen compounds (ammonia, nitrate, nitrite)
- Organic
- Chlorine or other oxidizing agents
- Oil and grease
- Other:
- NA (Skip to Question D4-12)

CBI?  
 Yes

D4-11. Of the pollutants listed in D4-10, which effluent limitation(s) drives/will drive the operation of this pond/impoundment unit? Provide the pollutant and the limitation (mg/L or ug/L).

Pollutant:

Limitation:

Pollutant:

Limitation:

Pollutant:

Limitation:

CBI?  
 Yes

D4-12. Did the plant add chemicals to this pond/impoundment unit in 2009?

- Yes: (Complete Table D-7)
- No: ([Skip to Section 4.2](#))
- No: (Pond/impoundment is planned to be constructed. Provide information in Table D-7 to the extent possible based on plans.)

Note that "Chemical Type" refers to the generic name of the chemical added to the pond/impoundment (e.g., lime, sodium hydroxide, alum, polymer). "Average Dose Concentration" refers to the average concentration of the chemical within the pond/impoundment unit just after it is added to the unit. In the "Location of Chemical Addition" column, indicate where within or near the pond/impoundment the chemical is added (e.g., within the pond/impoundment near the process wastewater influent point, within the pond/impoundment near the effluent, in the effluent/discharge canal). If chemical addition is known only on a yearly basis, divide the yearly value by the approximate number of days the plant added chemicals (which should be the same estimate for the "Frequency of Addition" column).

Table D-7. Chemicals Used in Pond/Impoundment Unit Operations

| Chemical Type | Trade Name | Manufacturer | Purpose | Location of Chemical Addition | Average Dose Concentration (g/L) | Average Addition Rate (gpd or lb/day)                   |  | Frequency of Addition (dpy) |
|---------------|------------|--------------|---------|-------------------------------|----------------------------------|---|--|-----------------------------|
|               |            |              |         |                               |                                  | <input type="radio"/> gpd<br><input type="radio"/> lb/d | <input type="radio"/> Sol<br><input type="radio"/> Liq |                             |
|               |            |              |         |                               |                                  | <input type="radio"/> gpd<br><input type="radio"/> lb/d | <input type="radio"/> Sol<br><input type="radio"/> Liq |                             |
|               |            |              |         |                               |                                  | <input type="radio"/> gpd<br><input type="radio"/> lb/d | <input type="radio"/> Sol<br><input type="radio"/> Liq |                             |
|               |            |              |         |                               |                                  | <input type="radio"/> gpd<br><input type="radio"/> lb/d | <input type="radio"/> Sol<br><input type="radio"/> Liq |                             |
|               |            |              |         |                               |                                  | <input type="radio"/> gpd<br><input type="radio"/> lb/d | <input type="radio"/> Sol<br><input type="radio"/> Liq |                             |
|               |            |              |         |                               |                                  | <input type="radio"/> gpd<br><input type="radio"/> lb/d | <input type="radio"/> Sol<br><input type="radio"/> Liq |                             |
|               |            |              |         |                               |                                  | <input type="radio"/> gpd<br><input type="radio"/> lb/d | <input type="radio"/> Sol<br><input type="radio"/> Liq |                             |
|               |            |              |         |                               |                                  | <input type="radio"/> gpd<br><input type="radio"/> lb/d | <input type="radio"/> Sol<br><input type="radio"/> Liq |                             |

Plant ID: Insert Plant ID

Plant Name: Insert Plant Name

Pond/Impoundment Unit ID: Insert Unit ID

**Part: D**

**Section Title:** 4.2. Closed Pond/Impoundment Unit Information

**Instructions:** Complete Section 4.2 (Questions D4-13 through D4-24) for all *pond/impoundment* units closed on or after January 1, 2000, including those located on non-adjointing property, that were used for the storage, treatment, and/or disposal of *process wastewater, residues, or by-products* (or *sludges* or water streams containing the residues or by-products) from the combustion of coal, petroleum coke, or oil, including but not limited to fly ash, bottom ash, boiler slag, or flue gas emission control residues (use pond/impoundment unit IDs assigned in Table A-4).

Make a copy of Section 4.2 for each closed pond/impoundment unit, including those located on non-adjointing property, that was used for the storage, treatment, and/or disposal of process wastewater, residues, or by-products (or sludges or water streams containing the residues or by-products) from the combustion of coal, petroleum coke, or oil, including but not limited to *fly ash, bottom ash, boiler slag, or flue gas emission control residues* using the "Copy Section 4.2" button below.

**NOTE: If a pond/impoundment was part of a broader wastewater treatment system containing *non-pond wastewater treatment units* (e.g., a pond/impoundment unit in a biological wastewater treatment system), complete questions in this section for the pond/impoundment unit.**

**CBI?**

Yes

**D4-13.** Are there any ponds/impoundments closed on or after January 1, 2000, including those located on non-adjointing property, that were used for the storage, treatment, and/or disposal of residues or by-products (or sludges or water streams containing the residues or by-products) from the combustion of coal, petroleum coke, or oil, including but not limited to fly ash, bottom ash, boiler slag, or flue gas emission control residues?

Yes (Continue)

No [\(Skip to Section 5.1\)](#)

**CBI?**  
 Yes

**D4-14.** Provide the date the pond/impoundment unit was closed, the actual life of the pond/impoundment unit, and the number of cells in the pond/impoundment unit.

Date Closed (day/month/year)

Life of pond/impoundment unit (years, actual)

Number of cells in pond/impoundment unit

**CBI?**  
 Yes

**D4-15.** Complete Table D-8. Provide the pond/impoundment unit's volume, surface area, bottom and top elevation, freeboard height, maximum height of berms and dams above the surrounding grade, and the total quantity of solids placed in the pond/impoundment when it was originally built and at its end of life. Volume should reflect original and final (accounting for any expansions) free water volume, including the stored solids. Please refer back to Figure D-1 for an illustration of pond/impoundment dimensions.

**Table D-8. Closed Pond/Impoundment Information**

|   | Originally Built | End of Life |
|---|------------------|-------------|
| Volume, ft <sup>3</sup>                           |                  |             |
| Surface area, ft <sup>2</sup>                     |                  |             |
| Bottom elevation, ft                              |                  |             |
| Top elevation, ft                                 |                  |             |
| Freeboard height, ft                              |                  |             |
| Maximum height of berms/dams above grade, ft      |                  |             |
| Total solids placed in the pond/impoundment, tons |                  |             |

**CBI?**  
 Yes

**D4-16.** Does the pond/impoundment unit have a *liner*?

- Yes (Complete Table D-9)
- No (Skip to Question D4-17)

**Table D-9. Pond/Impoundment Unit Liner**

| Liner Layer Number<br>(number from inner to<br>outer layer) | Type of Liner   | Thickness of Liner<br>Layer (cm) | Permeability of Liner Layer<br>(cm/sec) |
|---|---|----------------------------------|---|
|   | <input type="radio"/> Compacted clay<br><input type="radio"/> Geosynthetic clay<br><input type="radio"/> High density polyethylene (HDPE)<br><input type="radio"/> Other (provide below:) |                                  |   |
|   |   |                                  |   |
|   | <input type="radio"/> Compacted clay<br><input type="radio"/> Geosynthetic clay<br><input type="radio"/> High density polyethylene (HDPE)<br><input type="radio"/> Other (provide below:) |                                  |   |
|   |   |                                  |   |
|   | <input type="radio"/> Compacted clay<br><input type="radio"/> Geosynthetic clay<br><input type="radio"/> High density polyethylene (HDPE)<br><input type="radio"/> Other (provide below:) |                                  |   |
|   |   |                                  |   |
|   | <input type="radio"/> Compacted clay<br><input type="radio"/> Geosynthetic clay<br><input type="radio"/> High density polyethylene (HDPE)<br><input type="radio"/> Other (provide below:) |                                  |   |
|   |   |                                  |   |

|  |  |  |  |
|--|--|--|--|
|  | <input type="radio"/> Compacted clay<br><input type="radio"/> Geosynthetic clay                        |  |  |
|  | <input type="radio"/> High density polyethylene (HDPE)<br><input type="radio"/> Other (provide below:) |  |  |
|  |  |  |  |

**CBI?**

Yes

**D4-17.** Does the pond/impoundment unit have a cap/cover?

- Yes (Complete Table D-10)  
 No (Skip to Question D4-18)

**Table D-10. Pond/Impoundment Unit Cap/Cover**

| Cap/Cover Layer Number<br>(number from inner to<br>outer layer) | Type of Cap/Cover Layer   | Thickness of<br>Cap/Cover Layer (cm) | Permeability of Cap/Cover<br>Layer (cm/sec) |
|---|---|--------------------------------------|---|
|   | <input type="radio"/> Compacted clay<br><input type="radio"/> Geosynthetic clay   |                                      |   |
|   | <input type="radio"/> Vegetative cover<br><input type="radio"/> High density polyethylene (HDPE);<br><input type="radio"/> Other (provide below:) |                                      |   |
|   |   |                                      |   |
|   | <input type="radio"/> Compacted clay<br><input type="radio"/> Geosynthetic clay   |                                      |   |
|   | <input type="radio"/> Vegetative cover<br><input type="radio"/> High density polyethylene (HDPE);<br><input type="radio"/> Other (provide below:) |                                      |   |
|   |   |                                      |   |

|  |  |  |  |
|--|--|--|--|
|  | <input type="radio"/> Compacted clay<br><input type="radio"/> Geosynthetic clay<br><input type="radio"/> Vegetative cover<br><input type="radio"/> High density polyethylene (HDPE)<br><input type="radio"/> Other (provide below:)<br>_____ |  |  |
|  |  |  |  |
|  | <input type="radio"/> Compacted clay<br><input type="radio"/> Geosynthetic clay<br><input type="radio"/> Vegetative cover<br><input type="radio"/> High density polyethylene (HDPE)<br><input type="radio"/> Other (provide below:)<br>_____ |  |  |
|  |  |  |  |
|  | <input type="radio"/> Compacted clay<br><input type="radio"/> Geosynthetic clay<br><input type="radio"/> Vegetative cover<br><input type="radio"/> High density polyethylene (HDPE)<br><input type="radio"/> Other (provide below:)<br>_____ |  |  |
|  |  |  |  |
|  | <input type="radio"/> Compacted clay<br><input type="radio"/> Geosynthetic clay<br><input type="radio"/> High density polyethylene (HDPE)<br><input type="radio"/> Vegetative cover<br><input type="radio"/> Other (provide below:)<br>_____ |  |  |
|  |  |  |  |

**CBI?**

Yes

**D4-18.** Was the pond/impoundment unit expanded during its life?

- Yes (Continue)
- No (Skip to Question 4-21)

**CBI?**  
 Yes

**D4-19.** Identify the type of expansion.

- Lateral expansion
- Vertical expansion
- Both lateral and vertical expansion

**CBI?**  
 Yes

**D4-20.** Describe the expansion(s) to the pond/impoundment unit, including the starting and ending dimensions and the total capital and O&M costs associated with the expansion(s).

**Note: Total O&M costs should include labor, materials, energy, hazardous and nonhazardous waste disposal, and any other costs available. Total capital costs should include purchased equipment, installation, buildings, site preparation, land, engineering costs, construction expenses, and any other costs available.**

**CBI?**  
 Yes

**D4-21.** Did the plant have a closure plan for this pond/impoundment unit?

- Yes (Provide a copy of the closure plan)
- No (Continue)

**CBI?**  
 Yes

**D4-22.** Describe the closure process, the required steps, and the costs associated with the closure.

**Note: If you attached a closure plan for the previous question that includes information on the required steps and associated costs of the closure, do not answer this question and indicate that the information is provided in the attached closure plan.**

Information provided in attached closure plan



**CRI?**

Yes

**D4-23.** Has the plant built any structures on top of the closed pond/impoundment?

Yes (Continue)

No (Skip to Question D4-24)

Provide a description of the structure(s) and any challenges that the plant faced building on top of the pond/impoundment.

**CBI?**

Yes

**D4-24.** Is the plant performing or does it intend to perform long-term groundwater, soil, or overflow monitoring of this closed pond/impoundment unit?

Yes. Describe the monitorir

No

Plant ID: Insert Plant ID  
 Plant Name: Insert Plant Name  
 Wastewater Treatment System ID: Insert System ID

**Part: D**  
**Section Title:** 5.1. Wastewater Treatment Unit Information - System Level

**Instructions:** Complete Section 5.1 (Questions D5-1 through D5-12) for each *wastewater treatment system* identified in Table D-2, including planned (under construction/installation, or planned to be under construction/installation by December 31, 2020) wastewater treatment systems. Enter the wastewater treatment system ID in the space provided above (use wastewater treatment system ID assigned in Table D-2).

Make a copy of Section 5.1 for each wastewater treatment system identified in Table D-2 using the "Copy Section 5.1" button below.

**NOTE: If the wastewater treatment system includes a pond/impoundment unit, include the pond/impoundment unit in Table D-11.**

**CRI?**  
 Yes

**D5-1.** Did you identify any *wastewater treatment systems* in Table D-2?

- Yes (Continue)
- No ([Skip to Part D Section 6.1](#))

**CRI?**  
 Yes

**D5-2.** In Table D-11, list all *wastewater treatment units* comprising the *wastewater treatment system* including units that are under construction/installation, or planned to be under construction/installation by December 31, 2020, included in the wastewater treatment system. For each wastewater treatment unit, assign an ID using the wastewater treatment unit terms provided in the drop down menu (e.g., Clarification, Primary-1), which will be used throughout the remainder of the survey; however, if a pond/impoundment unit is included as part of the wastewater treatment system, enter the pond/impoundment unit ID assigned in Table A-4 in the space labeled "Pond ID". The drop down menu accounts for the possibility of multiple wastewater treatment units; they are numbered sequentially. Note that these terms originated from the code tables on the "Code Tables" tab, provided at the end of this workbook.

For example, if the wastewater treatment system includes two clarifiers, select Clarification, Primary-1 for the first clarifier and Clarification, Secondary-1 for the second. In the "Plant Designation" column, provide the plant's name for each wastewater treatment unit. In the "Date Added to WWT System" column, either enter the date the unit was/will be installed if the unit is a retrofit, or enter "original" if the unit was part of the original wastewater treatment system installation.

**Table D-11. Wastewater Treatment Units**

| Wastewater Treatment Unit ID  | Plant Designation | Date Added to Wastewater Treatment System (day/month/year) | Volume (ft <sup>3</sup> ) | Footprint/Surface Area (ft <sup>2</sup> ) | Residence Time (hours) | Materials of Construction [Check all boxes that apply.] |   |                                     |  |
|-------------------------------|-------------------|--|---------------------------|---|------------------------|---|---|-------------------------------------|--|
| <input type="text"/>          |                   |  |                           |   |                        | <input type="checkbox"/> 316L stain                     | <input type="checkbox"/> 255 stainl     | <input type="checkbox"/> Carbon s   |  |
| Other: <input type="text"/>   |                   |  |                           |   |                        | <input type="checkbox"/> 317LM stai                     | <input type="checkbox"/> 2205 stainless | <input type="checkbox"/> Fiberglass |  |
| Pond ID: <input type="text"/> |                   |  |                           |   |                        | <input type="checkbox"/> 317LMN sta                     | <input type="checkbox"/> 625 stainle    | <input type="checkbox"/> Titanium   |  |
| <input type="text"/>          |                   |  |                           |   |                        | <input type="checkbox"/> Carbon steel                   | <input type="checkbox"/> Oth            |                                     |  |
| <input type="text"/>          |                   |  |                           |   |                        | <input type="checkbox"/> 316L stain                     | <input type="checkbox"/> 255 stainl     | <input type="checkbox"/> Carbon s   |  |
| Other: <input type="text"/>   |                   |  |                           |   |                        | <input type="checkbox"/> 317LM stai                     | <input type="checkbox"/> 2205 stainless | <input type="checkbox"/> Fiberglass |  |
| Pond ID: <input type="text"/> |                   |  |                           |   |                        | <input type="checkbox"/> 317LMN sta                     | <input type="checkbox"/> 625 stainle    | <input type="checkbox"/> Titanium   |  |
| <input type="text"/>          |                   |  |                           |   |                        | <input type="checkbox"/> Carbon steel                   | <input type="checkbox"/> Oth            |                                     |  |
| <input type="text"/>          |                   |  |                           |   |                        | <input type="checkbox"/> 316L stain                     | <input type="checkbox"/> 255 stainl     | <input type="checkbox"/> Carbon s   |  |
| Other: <input type="text"/>   |                   |  |                           |   |                        | <input type="checkbox"/> 317LM stai                     | <input type="checkbox"/> 2205 stainless | <input type="checkbox"/> Fiberglass |  |
| Pond ID: <input type="text"/> |                   |  |                           |   |                        | <input type="checkbox"/> 317LMN sta                     | <input type="checkbox"/> 625 stainle    | <input type="checkbox"/> Titanium   |  |
| <input type="text"/>          |                   |  |                           |   |                        | <input type="checkbox"/> Carbon steel                   | <input type="checkbox"/> Oth            |                                     |  |
| <input type="text"/>          |                   |  |                           |   |                        | <input type="checkbox"/> 316L stain                     | <input type="checkbox"/> 255 stainl     | <input type="checkbox"/> Carbon s   |  |
| Other: <input type="text"/>   |                   |  |                           |   |                        | <input type="checkbox"/> 317LM stai                     | <input type="checkbox"/> 2205 stainless | <input type="checkbox"/> Fiberglass |  |
| Pond ID: <input type="text"/> |                   |  |                           |   |                        | <input type="checkbox"/> 317LMN sta                     | <input type="checkbox"/> 625 stainle    | <input type="checkbox"/> Titanium   |  |
| <input type="text"/>          |                   |  |                           |   |                        | <input type="checkbox"/> Carbon steel                   | <input type="checkbox"/> Oth            |                                     |  |

|          |  |  |  |  |  |                                      |   |                                     |
|----------|--|--|--|--|--|--------------------------------------|---|-------------------------------------|
|          |  |  |  |  |  | <input type="checkbox"/> 316L stain  | <input type="checkbox"/> 255 staink     | <input type="checkbox"/> Carbon c   |
| Other:   |  |  |  |  |  | <input type="checkbox"/> 317LM stai  | <input type="checkbox"/> 2205 stainless | <input type="checkbox"/> Fiberglass |
| Pond ID: |  |  |  |  |  | <input type="checkbox"/> 317LMN sta  | <input type="checkbox"/> 625 stainle    | <input type="checkbox"/> Titanium   |
|          |  |  |  |  |  | <input type="checkbox"/> Carbon stee | <input type="checkbox"/> Oth            |                                     |
|          |  |  |  |  |  | <input type="checkbox"/> 316L stain  | <input type="checkbox"/> 255 staink     | <input type="checkbox"/> Carbon s   |
| Other:   |  |  |  |  |  | <input type="checkbox"/> 317LM stai  | <input type="checkbox"/> 2205 stainless | <input type="checkbox"/> Fiberglass |
| Pond ID: |  |  |  |  |  | <input type="checkbox"/> 317LMN sta  | <input type="checkbox"/> 625 stainle    | <input type="checkbox"/> Titanium   |
|          |  |  |  |  |  | <input type="checkbox"/> Carbon stee | <input type="checkbox"/> Oth            |                                     |
|          |  |  |  |  |  | <input type="checkbox"/> 316L stain  | <input type="checkbox"/> 255 staink     | <input type="checkbox"/> Carbon c   |
| Other:   |  |  |  |  |  | <input type="checkbox"/> 317LM stai  | <input type="checkbox"/> 2205 stainless | <input type="checkbox"/> Fiberglass |
| Pond ID: |  |  |  |  |  | <input type="checkbox"/> 317LMN sta  | <input type="checkbox"/> 625 stainle    | <input type="checkbox"/> Titanium   |
|          |  |  |  |  |  | <input type="checkbox"/> Carbon stee | <input type="checkbox"/> Oth            |                                     |
|          |  |  |  |  |  | <input type="checkbox"/> 316L stain  | <input type="checkbox"/> 255 staink     | <input type="checkbox"/> Carbon s   |
| Other:   |  |  |  |  |  | <input type="checkbox"/> 317LM stai  | <input type="checkbox"/> 2205 stainless | <input type="checkbox"/> Fiberglass |
| Pond ID: |  |  |  |  |  | <input type="checkbox"/> 317LMN sta  | <input type="checkbox"/> 625 stainle    | <input type="checkbox"/> Titanium   |
|          |  |  |  |  |  | <input type="checkbox"/> Carbon stee | <input type="checkbox"/> Oth            |                                     |
|          |  |  |  |  |  | <input type="checkbox"/> 316L stain  | <input type="checkbox"/> 255 staink     | <input type="checkbox"/> Carbon c   |
| Other:   |  |  |  |  |  | <input type="checkbox"/> 317LM stai  | <input type="checkbox"/> 2205 stainless | <input type="checkbox"/> Fiberglass |
| Pond ID: |  |  |  |  |  | <input type="checkbox"/> 317LMN sta  | <input type="checkbox"/> 625 stainle    | <input type="checkbox"/> Titanium   |
|          |  |  |  |  |  | <input type="checkbox"/> Carbon stee | <input type="checkbox"/> Oth            |                                     |
|          |  |  |  |  |  | <input type="checkbox"/> 316L stain  | <input type="checkbox"/> 255 staink     | <input type="checkbox"/> Carbon s   |
| Other:   |  |  |  |  |  | <input type="checkbox"/> 317LM stai  | <input type="checkbox"/> 2205 stainless | <input type="checkbox"/> Fiberglass |
| Pond ID: |  |  |  |  |  | <input type="checkbox"/> 317LMN sta  | <input type="checkbox"/> 625 stainle    | <input type="checkbox"/> Titanium   |
|          |  |  |  |  |  | <input type="checkbox"/> Carbon stee | <input type="checkbox"/> Oth            |                                     |
|          |  |  |  |  |  | <input type="checkbox"/> 316L stain  | <input type="checkbox"/> 255 staink     | <input type="checkbox"/> Carbon c   |
| Other:   |  |  |  |  |  | <input type="checkbox"/> 317LM stai  | <input type="checkbox"/> 2205 stainless | <input type="checkbox"/> Fiberglass |
| Pond ID: |  |  |  |  |  | <input type="checkbox"/> 317LMN sta  | <input type="checkbox"/> 625 stainle    | <input type="checkbox"/> Titanium   |
|          |  |  |  |  |  | <input type="checkbox"/> Carbon stee | <input type="checkbox"/> Oth            |                                     |
|          |  |  |  |  |  | <input type="checkbox"/> 316L stain  | <input type="checkbox"/> 255 staink     | <input type="checkbox"/> Carbon s   |
| Other:   |  |  |  |  |  | <input type="checkbox"/> 317LM stai  | <input type="checkbox"/> 2205 stainless | <input type="checkbox"/> Fiberglass |
| Pond ID: |  |  |  |  |  | <input type="checkbox"/> 317LMN sta  | <input type="checkbox"/> 625 stainle    | <input type="checkbox"/> Titanium   |
|          |  |  |  |  |  | <input type="checkbox"/> Carbon stee | <input type="checkbox"/> Oth            |                                     |
|          |  |  |  |  |  | <input type="checkbox"/> 316L stain  | <input type="checkbox"/> 255 staink     | <input type="checkbox"/> Carbon c   |
| Other:   |  |  |  |  |  | <input type="checkbox"/> 317LM stai  | <input type="checkbox"/> 2205 stainless | <input type="checkbox"/> Fiberglass |
| Pond ID: |  |  |  |  |  | <input type="checkbox"/> 317LMN sta  | <input type="checkbox"/> 625 stainle    | <input type="checkbox"/> Titanium   |
|          |  |  |  |  |  | <input type="checkbox"/> Carbon stee | <input type="checkbox"/> Oth            |                                     |

|          |  |  |  |  |  |                                     |   |                                     |
|----------|--|--|--|--|--|-------------------------------------|---|-------------------------------------|
|          |  |  |  |  |  | <input type="checkbox"/> 316L stain | <input type="checkbox"/> 255 stainle    | <input type="checkbox"/> Carbon s   |
| Other:   |  |  |  |  |  | <input type="checkbox"/> 317LM stai | <input type="checkbox"/> 2205 stainless | <input type="checkbox"/> Fiberglass |
| Pond ID: |  |  |  |  |  | <input type="checkbox"/> 317LMN sta | <input type="checkbox"/> 625 stainle    | <input type="checkbox"/> titanium   |
|          |  |  |  |  |  | <input type="checkbox"/> Carbon ste | <input type="checkbox"/> Oth            |                                     |
|          |  |  |  |  |  | <input type="checkbox"/> 316L stain | <input type="checkbox"/> 255 stainle    | <input type="checkbox"/> Carbon s   |
| Other:   |  |  |  |  |  | <input type="checkbox"/> 317LM stai | <input type="checkbox"/> 2205 stainless | <input type="checkbox"/> Fiberglass |
| Pond ID: |  |  |  |  |  | <input type="checkbox"/> 317LMN sta | <input type="checkbox"/> 625 stainle    | <input type="checkbox"/> titanium   |
|          |  |  |  |  |  | <input type="checkbox"/> Carbon ste | <input type="checkbox"/> Oth            |                                     |
|          |  |  |  |  |  | <input type="checkbox"/> 316L stain | <input type="checkbox"/> 255 stainle    | <input type="checkbox"/> Carbon s   |
| Other:   |  |  |  |  |  | <input type="checkbox"/> 317LM stai | <input type="checkbox"/> 2205 stainless | <input type="checkbox"/> Fiberglass |
| Pond ID: |  |  |  |  |  | <input type="checkbox"/> 317LMN sta | <input type="checkbox"/> 625 stainle    | <input type="checkbox"/> titanium   |
|          |  |  |  |  |  | <input type="checkbox"/> Carbon ste | <input type="checkbox"/> Oth            |                                     |
|          |  |  |  |  |  | <input type="checkbox"/> 316L stain | <input type="checkbox"/> 255 stainle    | <input type="checkbox"/> Carbon s   |
| Other:   |  |  |  |  |  | <input type="checkbox"/> 317LM stai | <input type="checkbox"/> 2205 stainless | <input type="checkbox"/> Fiberglass |
| Pond ID: |  |  |  |  |  | <input type="checkbox"/> 317LMN sta | <input type="checkbox"/> 625 stainle    | <input type="checkbox"/> titanium   |
|          |  |  |  |  |  | <input type="checkbox"/> Carbon ste | <input type="checkbox"/> Oth            |                                     |

CBI?  Yes

D5-3. Provide the design flow rate for the wastewater treatment system, as well as both the average and maximum flow rates for 2009. In addition, provide the duration and frequency of the effluent transfers from the wastewater treatment system in 2009. If the wastewater treatment system is planned, only provide the design flow rate and enter "NA" in all other fields.

- Average design flow rate, gpm
- Maximum design flow rate, gpm
- Typical flow rate in 2009, gpm
- Maximum daily flow rate in 2009, gpm
- Maximum daily flow rate in 2009, gpd
- Duration of effluent transfers from treatment system in 2009, hpd
- Frequency of effluent transfers from treatment system in 2009, dpy

CBI?  Yes

D5-4. Indicate the pollutants targeted for removal by this wastewater treatment system using techniques other than solely settling (e.g., adding chemicals to remove certain metals). [Check all boxes that apply.]

- Metals (sp )
- TSS
- Nitrogen compounds (am )
- Organic
- Chlorine or other o )
- Oil and grea
- Other:
- NA  (kip to Question D5-6)

CBI?  Yes:

D5-5. Of the pollutants listed in D5-4, which effluent limitation(s) drives/will drive the operation of this pond/impoundment unit? Provide the pollutant and the limitation (mg/L or ug/L).

Pollutant:

Limitation:

Pollutant:

Limitation:

Pollutant:

Limitation:

CBI?  Yes:

D5-6. Is this wastewater treatment system capable of performing sulfide addition?

- Yes (Continue)
- No (Skip to Question D5-8)

CBI?  Yes:

D5-7. Is the plant currently performing sulfide addition?

- Yes
- No

CBI?  Yes:

D5-8. Provide information on any impacts that climate had, or will have, on the installation of the wastewater treatment system (e.g., equipment had to be housed inside due to cold winters, extra insulation was necessary to protect equipment in winter, warm climate allowed all wastewater treatment to be located outdoors).

CBI?  Yes:

D5-9. Provide information on any impacts that space availability had, or will have, on the design and/or cost of the wastewater treatment system (e.g., cost increases due to fitting the wastewater treatment system units into tight spaces and/or moving other equipment to accommodate the treatment system units).

CBI?  Yes:

D5-10. Provide the bid proposals and/or engineering reports that were prepared for the wastewater treatment system.

**Note: All bid proposals and/or engineering reports originally submitted to the plant as CBI, should be marked CBI for the purpose of this collection request.**

- I have attached the bid propos
- I did not attach the bid proposals/engir

CBI?  Yes:

D5-11. In Table D-12, list all planned improvements (including those currently under construction/installation or those planned to be under construction/installation by December 31, 2020) to the wastewater treatment system. For each planned improvement to the wastewater treatment system, provide the WWT Unit ID the improvement pertains to (if applicable), using the terms in the drop down menu; however, if the improvement relates directly to a pond/impoundment, use the pond/impoundment ID assigned in Table A-4. Provide a description of the improvement, the expected date of the improvement, and the total capital cost related to the improvement.

**Note: Total capital costs should include purchased equipment, installation, buildings, site preparation, land, engineering costs, construction expenses, and any other costs available.**

**Table D-12. Planned Improvements to the Wastewater Treatment System**

| Wastewater Treatment Unit ID | Description of Improvement | Expected Date of Improvement (day/month/year) | Total Capital Cost (\$) |
|------------------------------|----------------------------|---|-------------------------|
| Other: [Redacted]            | [Redacted]                 | [Redacted]                                    | [Redacted]              |
| Pond ID: [Redacted]          | [Redacted]                 | [Redacted]                                    | [Redacted]              |
| Other: [Redacted]            | [Redacted]                 | [Redacted]                                    | [Redacted]              |
| Pond ID: [Redacted]          | [Redacted]                 | [Redacted]                                    | [Redacted]              |
| Other: [Redacted]            | [Redacted]                 | [Redacted]                                    | [Redacted]              |
| Pond ID: [Redacted]          | [Redacted]                 | [Redacted]                                    | [Redacted]              |
| Other: [Redacted]            | [Redacted]                 | [Redacted]                                    | [Redacted]              |
| Pond ID: [Redacted]          | [Redacted]                 | [Redacted]                                    | [Redacted]              |
| Other: [Redacted]            | [Redacted]                 | [Redacted]                                    | [Redacted]              |
| Pond ID: [Redacted]          | [Redacted]                 | [Redacted]                                    | [Redacted]              |

**CRI?**  
 Yes

**D5-12.** Were any of the above planned improvements to the wastewater treatment system, or the planned wastewater treatment system, planned in preparation for potential limit changes in the future?

- Yes (Continue)
- No (Skip to Section 5.2)

Please identify which pollutants and/or limits, in particular, the improvements or system will target.

Plant ID: Insert Plant ID  
 Plant Name: Insert Plant Name  
 Wastewater Treatment System ID: Insert System ID

**Part: D**  
**Section Title:** 5.2. Wastewater Treatment System Chemical Addition

**Instructions:** Complete Section 5.2 (Question D5-13) for each *wastewater treatment system* identified in Table D-2 (including those under construction/installation or planned to be under construction/installation by December 31, 2020). Do NOT complete Questions D5-8 through D5-12 for *pond/impoundment units* that are part of a wastewater treatment system (e.g. a pond/impoundment unit which is part of a biological wastewater treatment system). Enter the wastewater treatment system ID in the spaces provided above (use wastewater treatment system IDs assigned in Table D-2).

Make a copy of Section 5.2 for each wastewater treatment system identified in Table D-2 using the "Copy Section 5.2" button below.

CBI?  
 Yes

**D5-13.** Did the plant add chemicals to any *wastewater treatment units* 2009?

- Yes (Complete Table D-13)
- No (Skip to Section 6.1)
- No (Wastewater treatment unit is planned to be constructed. Provide information in Table D-13 to the extent possible based on plans.)

Complete Table D-13 for each unit (as defined in Table D-11) that chemicals are added to in the wastewater treatment system. Complete a row for each chemical added to each unit in the system.

Note that "Chemical Type" refers to the generic name of the chemical added to the wastewater treatment unit (e.g., lime, organosulfide). "Average Dose Concentration" refers to the average concentration of the chemical within the wastewater treatment unit just after it is added to the unit. If chemical addition is known only on a yearly basis, divide the yearly value by the approximate number of days the plant added chemicals (which should be the same estimate for the "Frequency of Addition" column).

**Table D-13. Chemicals Used in Wastewater Treatment Unit Operations**

| Wastewater Treatment Unit ID (Identified in Table D-11) | Chemical Type | Trade Name | Manufacturer | Purpose | Average Dose Concentration (g/L) | Average Addition Rate (gpd or lb/day) |                            | Frequency of Addition (dpy) |
|---|---------------|------------|--------------|---------|----------------------------------|---------------------------------------|----------------------------|-----------------------------|
|   |               |            |              |         |                                  |                                       |                            |                             |
|   |               |            |              |         |                                  | <input type="radio"/> gpd             | <input type="radio"/> Soli |                             |
| Other:  |               |            |              |         |                                  | <input type="radio"/> lb/d            | <input type="radio"/> Lic  |                             |
|   |               |            |              |         |                                  | <input type="radio"/> gp              | <input type="radio"/> So   |                             |
| Other:  |               |            |              |         |                                  | <input type="radio"/> lb/             | <input type="radio"/> Liq  |                             |
|   |               |            |              |         |                                  | <input type="radio"/> g/l             | <input type="radio"/> Soli |                             |
| Other:  |               |            |              |         |                                  | <input type="radio"/> lb/l            | <input type="radio"/> Liq  |                             |
|   |               |            |              |         |                                  | <input type="radio"/> g/c             | <input type="radio"/> Soli |                             |
| Other:  |               |            |              |         |                                  | <input type="radio"/> lb/c            | <input type="radio"/> Lic  |                             |
|   |               |            |              |         |                                  | <input type="radio"/> g/l             | <input type="radio"/> Sc   |                             |
| Other:  |               |            |              |         |                                  | <input type="radio"/> lb/l            | <input type="radio"/> Liq  |                             |
|   |               |            |              |         |                                  | <input type="radio"/> gpd             | <input type="radio"/> Soli |                             |
| Other:  |               |            |              |         |                                  | <input type="radio"/> lb/d            | <input type="radio"/> Lic  |                             |
|   |               |            |              |         |                                  | <input type="radio"/> gp              | <input type="radio"/> So   |                             |
| Other:  |               |            |              |         |                                  | <input type="radio"/> lb/             | <input type="radio"/> Liq  |                             |

|        |  |  |  |  |  |  |  |  |   |  |
|--------|--|--|--|--|--|--|--|--|---|--|
|        |  |  |  |  |  |  |  | <input type="radio"/> gp<br><input type="radio"/> lb/y | <input type="radio"/> Soli<br><input type="radio"/> Liq |  |
| Other: |  |  |  |  |  |  |  | <input type="radio"/> gp<br><input type="radio"/> lb/y | <input type="radio"/> Soli<br><input type="radio"/> Liq |  |
|        |  |  |  |  |  |  |  | <input type="radio"/> gp<br><input type="radio"/> lb/c | <input type="radio"/> Soli<br><input type="radio"/> Lic |  |
| Other: |  |  |  |  |  |  |  | <input type="radio"/> gp<br><input type="radio"/> lb/y | <input type="radio"/> Sc<br><input type="radio"/> Liq   |  |
|        |  |  |  |  |  |  |  | <input type="radio"/> gp<br><input type="radio"/> lb/d | <input type="radio"/> Soli<br><input type="radio"/> Lic |  |
| Other: |  |  |  |  |  |  |  | <input type="radio"/> gp<br><input type="radio"/> lb/  | <input type="radio"/> So<br><input type="radio"/> Liq   |  |
|        |  |  |  |  |  |  |  | <input type="radio"/> gp<br><input type="radio"/> lb/y | <input type="radio"/> Soli<br><input type="radio"/> Liq |  |
| Other: |  |  |  |  |  |  |  | <input type="radio"/> gp<br><input type="radio"/> lb/c | <input type="radio"/> Soli<br><input type="radio"/> Lic |  |
|        |  |  |  |  |  |  |  | <input type="radio"/> gp<br><input type="radio"/> lb/y | <input type="radio"/> Sc<br><input type="radio"/> Liq   |  |
| Other: |  |  |  |  |  |  |  | <input type="radio"/> gp<br><input type="radio"/> lb/d | <input type="radio"/> Soli<br><input type="radio"/> Lic |  |
|        |  |  |  |  |  |  |  | <input type="radio"/> gp<br><input type="radio"/> lb/  | <input type="radio"/> So<br><input type="radio"/> Liq   |  |
| Other: |  |  |  |  |  |  |  | <input type="radio"/> gp<br><input type="radio"/> lb/y | <input type="radio"/> Soli<br><input type="radio"/> Liq |  |
|        |  |  |  |  |  |  |  | <input type="radio"/> gp<br><input type="radio"/> lb/c | <input type="radio"/> Soli<br><input type="radio"/> Lic |  |
| Other: |  |  |  |  |  |  |  | <input type="radio"/> gp<br><input type="radio"/> lb/y | <input type="radio"/> Sc<br><input type="radio"/> Liq   |  |
|        |  |  |  |  |  |  |  | <input type="radio"/> gp<br><input type="radio"/> lb/d | <input type="radio"/> Soli<br><input type="radio"/> Lic |  |
| Other: |  |  |  |  |  |  |  | <input type="radio"/> gp<br><input type="radio"/> lb/  | <input type="radio"/> So<br><input type="radio"/> Liq   |  |
|        |  |  |  |  |  |  |  | <input type="radio"/> gp<br><input type="radio"/> lb/y | <input type="radio"/> Soli<br><input type="radio"/> Liq |  |
| Other: |  |  |  |  |  |  |  | <input type="radio"/> gp<br><input type="radio"/> lb/c | <input type="radio"/> Soli<br><input type="radio"/> Lic |  |
|        |  |  |  |  |  |  |  | <input type="radio"/> gp<br><input type="radio"/> lb/y | <input type="radio"/> Sc<br><input type="radio"/> Liq   |  |
| Other: |  |  |  |  |  |  |  | <input type="radio"/> gp<br><input type="radio"/> lb/d | <input type="radio"/> Soli<br><input type="radio"/> Lic |  |
|        |  |  |  |  |  |  |  | <input type="radio"/> gp<br><input type="radio"/> lb/  | <input type="radio"/> So<br><input type="radio"/> Liq   |  |
| Other: |  |  |  |  |  |  |  | <input type="radio"/> gp<br><input type="radio"/> lb/y | <input type="radio"/> Soli<br><input type="radio"/> Liq |  |
|        |  |  |  |  |  |  |  | <input type="radio"/> gp<br><input type="radio"/> lb/c | <input type="radio"/> Soli<br><input type="radio"/> Lic |  |
| Other: |  |  |  |  |  |  |  | <input type="radio"/> gp<br><input type="radio"/> lb/y | <input type="radio"/> Sc<br><input type="radio"/> Liq   |  |
|        |  |  |  |  |  |  |  | <input type="radio"/> gp<br><input type="radio"/> lb/d | <input type="radio"/> Soli<br><input type="radio"/> Lic |  |
| Other: |  |  |  |  |  |  |  | <input type="radio"/> gp<br><input type="radio"/> lb/  | <input type="radio"/> So<br><input type="radio"/> Liq   |  |



|        |  |  |  |  |  |  |  |                            |                            |  |
|--------|--|--|--|--|--|--|--|----------------------------|----------------------------|--|
|        |  |  |  |  |  |  |  | <input type="radio"/> g/c  | <input type="radio"/> Soli |  |
| Other: |  |  |  |  |  |  |  | <input type="radio"/> lb/i | <input type="radio"/> Liq  |  |
|        |  |  |  |  |  |  |  | <input type="radio"/> g/c  | <input type="radio"/> Soli |  |
| Other: |  |  |  |  |  |  |  | <input type="radio"/> lb/c | <input type="radio"/> Lic  |  |
|        |  |  |  |  |  |  |  | <input type="radio"/> g/c  | <input type="radio"/> Sc   |  |
| Other: |  |  |  |  |  |  |  | <input type="radio"/> lb/i | <input type="radio"/> Liq  |  |
|        |  |  |  |  |  |  |  | <input type="radio"/> g/c  | <input type="radio"/> Soli |  |
| Other: |  |  |  |  |  |  |  | <input type="radio"/> lb/d | <input type="radio"/> Lic  |  |
|        |  |  |  |  |  |  |  | <input type="radio"/> gp   | <input type="radio"/> So   |  |
| Other: |  |  |  |  |  |  |  | <input type="radio"/> lb/  | <input type="radio"/> Liq  |  |
|        |  |  |  |  |  |  |  | <input type="radio"/> g/c  | <input type="radio"/> Soli |  |
| Other: |  |  |  |  |  |  |  | <input type="radio"/> lb/i | <input type="radio"/> Liq  |  |
|        |  |  |  |  |  |  |  | <input type="radio"/> g/c  | <input type="radio"/> Soli |  |
| Other: |  |  |  |  |  |  |  | <input type="radio"/> lb/c | <input type="radio"/> Lic  |  |
|        |  |  |  |  |  |  |  | <input type="radio"/> g/c  | <input type="radio"/> Sc   |  |
| Other: |  |  |  |  |  |  |  | <input type="radio"/> lb/i | <input type="radio"/> Liq  |  |
|        |  |  |  |  |  |  |  | <input type="radio"/> g/c  | <input type="radio"/> Soli |  |
| Other: |  |  |  |  |  |  |  | <input type="radio"/> lb/d | <input type="radio"/> Lic  |  |
|        |  |  |  |  |  |  |  | <input type="radio"/> gp   | <input type="radio"/> So   |  |
| Other: |  |  |  |  |  |  |  | <input type="radio"/> lb/  | <input type="radio"/> Liq  |  |
|        |  |  |  |  |  |  |  | <input type="radio"/> g/c  | <input type="radio"/> Soli |  |
| Other: |  |  |  |  |  |  |  | <input type="radio"/> lb/i | <input type="radio"/> Liq  |  |
|        |  |  |  |  |  |  |  | <input type="radio"/> g/c  | <input type="radio"/> Soli |  |
| Other: |  |  |  |  |  |  |  | <input type="radio"/> lb/c | <input type="radio"/> Lic  |  |
|        |  |  |  |  |  |  |  | <input type="radio"/> g/c  | <input type="radio"/> Sc   |  |
| Other: |  |  |  |  |  |  |  | <input type="radio"/> lb/i | <input type="radio"/> Liq  |  |
|        |  |  |  |  |  |  |  | <input type="radio"/> g/c  | <input type="radio"/> Soli |  |
| Other: |  |  |  |  |  |  |  | <input type="radio"/> lb/d | <input type="radio"/> Lic  |  |
|        |  |  |  |  |  |  |  | <input type="radio"/> gp   | <input type="radio"/> So   |  |
| Other: |  |  |  |  |  |  |  | <input type="radio"/> lb/  | <input type="radio"/> Liq  |  |
|        |  |  |  |  |  |  |  | <input type="radio"/> g/c  | <input type="radio"/> Soli |  |
| Other: |  |  |  |  |  |  |  | <input type="radio"/> lb/i | <input type="radio"/> Liq  |  |
|        |  |  |  |  |  |  |  | <input type="radio"/> g/c  | <input type="radio"/> Soli |  |
| Other: |  |  |  |  |  |  |  | <input type="radio"/> lb/i | <input type="radio"/> Liq  |  |

|        |  |  |  |  |  |  |  |                            |                            |  |
|--------|--|--|--|--|--|--|--|----------------------------|----------------------------|--|
|        |  |  |  |  |  |  |  | <input type="radio"/> gp   | <input type="radio"/> Soli |  |
| Other: |  |  |  |  |  |  |  | <input type="radio"/> lb/c | <input type="radio"/> Lic  |  |
|        |  |  |  |  |  |  |  | <input type="radio"/> gp   | <input type="radio"/> Sc   |  |
| Other: |  |  |  |  |  |  |  | <input type="radio"/> lb/l | <input type="radio"/> Liq  |  |
|        |  |  |  |  |  |  |  | <input type="radio"/> gp   | <input type="radio"/> Soli |  |
| Other: |  |  |  |  |  |  |  | <input type="radio"/> lb/d | <input type="radio"/> Lic  |  |
|        |  |  |  |  |  |  |  | <input type="radio"/> gp   | <input type="radio"/> So   |  |
| Other: |  |  |  |  |  |  |  | <input type="radio"/> lb/  | <input type="radio"/> Liq  |  |
|        |  |  |  |  |  |  |  | <input type="radio"/> gp   | <input type="radio"/> Soli |  |
| Other: |  |  |  |  |  |  |  | <input type="radio"/> lb/l | <input type="radio"/> Liq  |  |
|        |  |  |  |  |  |  |  | <input type="radio"/> gp   | <input type="radio"/> Soli |  |
| Other: |  |  |  |  |  |  |  | <input type="radio"/> lb/c | <input type="radio"/> Lic  |  |
|        |  |  |  |  |  |  |  | <input type="radio"/> gp   | <input type="radio"/> Sc   |  |
| Other: |  |  |  |  |  |  |  | <input type="radio"/> lb/l | <input type="radio"/> Liq  |  |
|        |  |  |  |  |  |  |  | <input type="radio"/> gp   | <input type="radio"/> Soli |  |
| Other: |  |  |  |  |  |  |  | <input type="radio"/> lb/d | <input type="radio"/> Lic  |  |
|        |  |  |  |  |  |  |  | <input type="radio"/> gp   | <input type="radio"/> So   |  |
| Other: |  |  |  |  |  |  |  | <input type="radio"/> lb/  | <input type="radio"/> Liq  |  |
|        |  |  |  |  |  |  |  | <input type="radio"/> gp   | <input type="radio"/> Soli |  |
| Other: |  |  |  |  |  |  |  | <input type="radio"/> lb/l | <input type="radio"/> Liq  |  |
|        |  |  |  |  |  |  |  | <input type="radio"/> gp   | <input type="radio"/> Soli |  |
| Other: |  |  |  |  |  |  |  | <input type="radio"/> lb/c | <input type="radio"/> Lic  |  |
|        |  |  |  |  |  |  |  | <input type="radio"/> gp   | <input type="radio"/> Sc   |  |
| Other: |  |  |  |  |  |  |  | <input type="radio"/> lb/l | <input type="radio"/> Liq  |  |
|        |  |  |  |  |  |  |  | <input type="radio"/> gp   | <input type="radio"/> Soli |  |
| Other: |  |  |  |  |  |  |  | <input type="radio"/> lb/d | <input type="radio"/> Lic  |  |
|        |  |  |  |  |  |  |  | <input type="radio"/> gp   | <input type="radio"/> So   |  |
| Other: |  |  |  |  |  |  |  | <input type="radio"/> lb/  | <input type="radio"/> Liq  |  |
|        |  |  |  |  |  |  |  | <input type="radio"/> gp   | <input type="radio"/> Soli |  |
| Other: |  |  |  |  |  |  |  | <input type="radio"/> lb/l | <input type="radio"/> Liq  |  |
|        |  |  |  |  |  |  |  | <input type="radio"/> gp   | <input type="radio"/> Soli |  |
| Other: |  |  |  |  |  |  |  | <input type="radio"/> lb/c | <input type="radio"/> Lic  |  |
|        |  |  |  |  |  |  |  | <input type="radio"/> gp   | <input type="radio"/> Sc   |  |
| Other: |  |  |  |  |  |  |  | <input type="radio"/> lb/l | <input type="radio"/> Liq  |  |

Plant ID: Insert Plant ID

Plant Name: Insert Plant Name

Pond/Impoundment System ID or Wastewater Treatment System ID: Insert System ID

**Part: D**

**Section Title: 6.1. Pond/Impoundment System and Wastewater Treatment System Costs**

**Instructions:** Complete Sections 6.1 and 6.2 (Questions D6-1 through D6-6) for each *pond/impoundment system* and/or *wastewater treatment system* identified in Table D-1 and Table D-2 that was installed (or is planned to be installed) at the plant on or after January 1, 1985. Enter the pond/impoundment system ID or wastewater treatment system ID in the space provided above (use pond/impoundment system IDs and wastewater treatment system IDs assigned in Table D-1 and Table D-2).

Make a copy of Sections 6.1 and 6.2 for each pond/impoundment system and/or wastewater treatment system identified in Table D-1 and Table D-2 using the "Copy Section 6.1 and 6.2" button below. Just pressing this button once will generate copies of both tabs.

**CBI?**  
 Yes

**D6-1.** Were any of the pond/impoundment systems and/or wastewater treatment systems identified in Table D-1 or Table D-2 installed (or planned to be installed) after January 1, 1985?

- Yes (Continue)
- No (Skip to next Questionnaire Part)

**CBI?**  
 Yes

**D6-2.** Provide annual O&M cost data in Table D-14 for each pond/impoundment system and wastewater treatment system identified in Table D-1 and Table D-2 (installed or planned to be installed after January 1, 1985) that was operated in 2009. Provide best engineering estimates when actual data are not readily available. If you provide an estimate, note the methods that were used to make the estimates in the Comments page.

**Table D-14. O&M Cost for the Pond/Impoundment System or Wastewater Treatment System for 2009**

| O&M Cost Category     | 2009 Annual Cost        | 2009 Rate  | 2009 Staffing/ Consumption  |
|-----------------------|-------------------------|--|---|
| Operating labor       | \$ <input type="text"/> | \$ <input type="text"/> per hour (average rate of labor) | <input type="text"/> No. of workers<br><input type="text"/> hpd<br><input type="text"/> dpy |
| Maintenance labor     | \$ <input type="text"/> | \$ <input type="text"/> per hour (average rate of labor) | <input type="text"/> No. of workers<br><input type="text"/> hpd<br><input type="text"/> dpy |
| Maintenance materials | \$ <input type="text"/> |  |   |
| Chemicals             | \$ <input type="text"/> |  |   |

|  |               |   |                      |
|--|---------------|---|----------------------|
| Energy - Power for pumping                       | \$ [redacted] | \$ [redacted] per kWh   | [redacted] kWh/hr    |
| Energy - Power for operations other than pumping | \$ [redacted] | \$ [redacted] per kWh   | [redacted] kWh/hr    |
| Steam  | \$ [redacted] | \$ [redacted] per pound   | [redacted] pounds/hr |
| Hazardous Sludge Disposal - Dredging             | \$ [redacted] | \$ [redacted] per <input type="radio"/> Gallon<br><input type="radio"/> Ton |                      |
| Hazardous Sludge Disposal - Landfilling          | \$ [redacted] | \$ [redacted] per <input type="radio"/> Gallon<br><input type="radio"/> Ton |                      |
| Nonhazardous Sludge Disposal - Dredging          | \$ [redacted] | \$ [redacted] per <input type="radio"/> Gallon<br><input type="radio"/> Ton |                      |
| Nonhazardous Sludge Disposal - Landfilling       | \$ [redacted] | \$ [redacted] per <input type="radio"/> Gallon<br><input type="radio"/> Ton |                      |
| Other:   | \$ [redacted] |   |                      |
| Other:   | \$ [redacted] |   |                      |
| <b>Total O&amp;M Cost (2009)</b>                 | \$ [redacted] |   |                      |

**CBI?**  
 Yes

**D6-3.** Provide cost data in Table D-15 for each pond/impoundment systems and wastewater treatment system identified in Table D-1 and Table D-2 (installed or planned to be installed after January 1, 1985), including retired/closed pond/impoundment systems, planned pond/impoundment systems, and planned wastewater treatment systems (including those under construction/installation or planned to be under construction/installation by December 31, 2020). Provide best engineering estimates when actual data are not readily available. For all costs, do not adjust for inflation. For example, if the plant incurred a land cost in 2002, enter the cost in the "Cost" column and enter "2002" in the "Year on which Cost is Based" column.

**NOTE:** If no records are available on this wastewater treatment system, provide an explanation in the Comments page.

**Table D-15. Capital Cost for the Pond/Impoundment System or Wastewater Treatment System**

| Project   | Cost      | Year on which Cost is Based |
|---|-----------|-----------------------------|
| <b>Direct Costs</b>   |           |                             |
| <u>Purchased equipment</u> (includes all equipment for the installation or the upgrade: mechanical equipment; piping; instrumentation; electrical equipment; spare parts; freight charges; taxes; insurance; and duties)  | \$        |                             |
| <u>Purchased equipment installation</u> (includes installation of all equipment; piping; instrumentation/calibration; electrical equipment; mechanical equipment; structural supports, insulation, and paint)   | \$        |                             |
| <u>Buildings</u> (buildings constructed to house ash handling system components, operator rooms, or other operations associated with the system; also includes plumbing, heating, ventilation, dust collection, air conditioning, lighting, telephones, intercoms, painting, sprinklers, fire alarms) | \$        |                             |
| <u>Site preparation</u> (includes site clearing, all demolition, grading, roads, walking areas, fences)   | \$        |                             |
| <u>Land</u> (includes property costs and survey fees)   | \$        |                             |
| <b>Total Direct Costs</b>   | <b>\$</b> |                             |
| <b>Indirect Costs</b>   |           |                             |
| <u>Engineering Costs</u> (includes process design and general engineering, cost engineering, consulting fees, supervision, inspection for each category below:<br><br>a. Engineering Contract Firm Costs<br>b. Owner's Overhead Engineering Costs)  | \$        |                             |
| <input type="checkbox"/> <u>Hired outside engineering firm to oversee design and/or</u>   |           |                             |
| <u>Construction expenses</u> (includes temporary construction offices, roads, communications, fencing; construction tools and equipment; permits, taxes, insurance)   | \$        |                             |
| <u>Other Contractor's Fees</u>  | \$        |                             |
| <u>Contingency actually expended</u> (to compensate for unpredictable events such as storms, floods, strikes, price changes, errors in estimates, design changes, etc.)   | \$        |                             |
| <b>Total Indirect Costs</b>   | <b>\$</b> |                             |
| <b>Total Capital Cost</b>   | <b>\$</b> |                             |

**CBI?**  
 Yes

**D6-4.** If applicable, indicate whether the FGD wastewater treatment system, for which the plant provided capital cost data in Table D-15, was a retrofit or was installed when the *FGD scrubber system* was installed.

- FGD wastewater treatment system was a retro
- FGD wastewater treatment system was installed when the F
- NA

**CBI?**  
 Yes

**D6-5.** If applicable, indicate whether the FGD wastewater treatment system, for which the plant provide capital cost data in Table D-15, was purchased as part of the FGD scrubber package.

- FGD wastewater treatment system was purchased as par
- FGD wastewater treatment system was not purchased as p
- NA

Plant ID: Insert Plant ID

Plant Name: Insert Plant Name

Pond/Impoundment System ID or Wastewater Treatment System ID: Insert System ID

**Part: D**

**Section Title:** 6.2. Pond/Impoundment System and Wastewater Treatment System Equipment

**Instructions:** Complete Section 6.2 (Question D6-6) for all ancillary pieces of equipment included in the *pond/impoundment system* or *wastewater treatment system* that contribute to the capital costs provided in Table D-15.

~~Note: This tab will copy with every copy made for the previous tab (Part D Section 6.1) as the~~

**CBI?**  
 Yes

**D6-6.** In Table D-16, list any ancillary pieces of equipment (i.e., equipment such as pumps and agitators) included in the pond/impoundment system or wastewater treatment system that contribute significantly to the capital costs provided in Table D-16 and provide the total number of pieces of that equipment included in the system. Refer to the examples of ancillary equipment shown below.

Examples of ancillary equipment:

- Aerator
- Agitator
- Chemical feed system (specify chemicals)
- Pump, sludge (specify purpose/location)
- Pump, wastewater (specify purpose/location)

**Table D-16. Ancillary Equipment of the Pond/Impoundment System  
or Wastewater Treatment System**

| Ancillary Equipment (if applicable)                     | Number of Ancillary Equipment Pieces in the System |
|---|--|
| <i>Pump, sludge (serving underflow from clarifiers)</i> | 2  |
|   |  |
|   |  |
|   |  |
|   |  |
|   |  |
|   |  |
|   |  |
|   |  |
|   |  |
|   |  |
|   |  |
|   |  |
|   |  |
|   |  |





|  |  |
|--|--|
|  |  |
|  |  |

**Part D Drop Downs**

| Process Wastewaters   |
|---|
| Select  |
| Air heater cleaning water   |
| Ash pile runoff   |
| Boiler blowdown   |
| Boiler fireside cleaning water  |
| Boiler tube cleaning water  |
| Bottom ash sluice   |
| Carbon capture wastewater   |
| Coal pile runoff  |
| Combined ash sluice   |
| Combustion turbine cleaning (combustion gas portion of turbine) water |
| Combustion turbine cleaning (compressor portion of the turbine) water |
| Combustion turbine evaporative coolers blowdown                       |
| Cooling tower blowdown  |
| FGD scrubber purge  |
| FGD slurry blowdown   |
| Filter Backwash   |
| Floor drain wastewater  |
| Flue gas mercury control system wastewater                            |
| Fly ash sluice  |
| General runoff  |
| Gypsum pile runoff  |
| Gypsum wash water   |
| Ion exchange wastewater   |
| Landfill runoff - capped landfill                                     |
| Landfill runoff - uncapped landfill                                   |
| Leachate  |
| Limestone pile runoff   |
| Mill reject sluice  |
| Once-through cooling water  |
| Reverse osmosis reject water  |
| SCR catalyst regeneration wastewater                                  |
| SCR catalyst washing wastewater                                       |
| Soot blowing wash water   |
| Steam turbine cleaning water  |
| Yard drain wastewater   |
| Other   |

| <b>Treated Wastewaters</b> |
|----------------------------|
| Select                     |
| Effluent - 1               |
| Effluent - 2               |
| Effluent - 3               |
| Effluent - 4               |
| Effluent - 5               |
| Effluent - 6               |
| Filter backwash            |
| POND-1 Effluent            |
| POND-2 Effluent            |
| POND-3 Effluent            |
| POND-4 Effluent            |
| POND-5 Effluent            |
| POND-6 Effluent            |
| POND-7 Effluent            |
| POND-8 Effluent            |
| POND-9 Effluent            |
| POND-10 Effluent           |
| POND-A Effluent            |
| POND-B Effluent            |
| POND-C Effluent            |
| Sludge                     |
| WWT-1 Effluent             |
| WWT-2 Effluent             |
| WWT-3 Effluent             |
| WWT-4 Effluent             |
| WWT-5 Effluent             |
| WWT-6 Effluent             |
| WWT-A Effluent             |
| WWT-B Effluent             |
| WWT-C Effluent             |
| Other                      |

| <b>Process or Treated Wastewater (Influent Table D-3)</b>             |
|---|
| Select  |
| Air heater cleaning water   |
| Ash pile runoff   |
| Boiler blowdown   |
| Boiler fireside cleaning water  |
| Boiler tube cleaning water  |
| Bottom ash sluice   |
| Carbon capture wastewater   |
| Coal pile runoff  |
| Combined ash sluice   |
| Combustion turbine cleaning (combustion gas portion of turbine) water |
| Combustion turbine cleaning (compressor portion of the turbine) water |
| Combustion turbine evaporative coolers blowdown                       |
| Cooling tower blowdown  |
| FGD scrubber purge  |
| FGD slurry blowdown   |
| Filter Backwash   |
| Floor drain wastewater  |
| Flue gas mercury control system wastewater                            |
| Fly ash sluice  |
| General runoff  |
| Gypsum pile runoff  |
| Gypsum wash water   |
| Ion exchange wastewater   |
| Landfill runoff - capped landfill                                     |
| Landfill runoff - uncapped landfill                                   |
| Leachate  |
| Limestone pile runoff   |
| Mill reject sluice  |
| Once-through cooling water  |
| Reverse osmosis reject water  |
| SCR catalyst regeneration wastewater                                  |
| SCR catalyst washing wastewater                                       |
| Sludge  |
| Soot blowing wash water   |
| Steam turbine cleaning water  |
| Yard drain wastewater   |
| POND-1 Effluent   |
| POND-2 Effluent   |
| POND-3 Effluent   |
| POND-4 Effluent   |
| POND-5 Effluent   |
| POND-6 Effluent   |
| POND-7 Effluent   |
| POND-8 Effluent   |
| POND-9 Effluent   |
| POND-10 Effluent  |
| POND-A Effluent   |
| POND-B Effluent   |
| POND-C Effluent   |
| WWT-1 Effluent  |
| WWT-2 Effluent  |
| WWT-3 Effluent  |

|                |
|----------------|
| WWT-4 Effluent |
| WWT-5 Effluent |
| WWT-6 Effluent |
| WWT-A Effluent |
| WWT-B Effluent |
| WWT-C Effluent |
| Other          |

| <b>Treated Wastewater (Effluents Table D-4)</b> |
|---|
| Select  |
| Effluent - 1                                    |
| Effluent - 2                                    |
| Effluent - 3                                    |
| Effluent - 4                                    |
| Effluent - 5                                    |
| Effluent - 6                                    |
| Filter backwash                                 |
| Sludge  |
| Other   |

| <b>Wastewater Treatment Units</b>          |
|--|
| Select                                     |
| Adsorptive media                           |
| Aerobic Biological Reactor                 |
| Aerobic/Anaerobic Biological Reactor       |
| Anaerobic Biological Reactor               |
| Chemical Precipitation Reaction Tank 1 - 1 |
| Chemical Precipitation Reaction Tank 1 - 2 |
| Chemical Precipitation Reaction Tank 2 - 1 |
| Chemical Precipitation Reaction Tank 2 - 2 |
| Chemical Precipitation Reaction Tank 3 - 1 |
| Chemical Precipitation Reaction Tank 3 - 2 |
| Clarification, Primary - 1                 |
| Clarification, Primary - 2                 |
| Clarification, Secondary - 1               |
| Clarification, Secondary - 2               |
| Clarification, Tertiary - 1                |
| Clarification, Tertiary - 2                |
| Constructed wetlands                       |
| Equalization, Primary                      |
| Equalization, Secondary                    |
| Filter press - 1                           |
| Filter press - 2                           |
| Filter, Microfiltration - 1                |
| Filter, Microfiltration - 2                |
| Filter, Microfiltration - 3                |
| Filter, Microfiltration - 4                |
| Filter, Sand/Gravity - 1                   |
| Filter, Sand/Gravity - 2                   |
| Filter, Sand/Gravity - 3                   |
| Filter, Sand/Gravity - 4                   |
| Filter, Ultrafiltration - 1                |
| Filter, Ultrafiltration - 2                |
| Filter, Ultrafiltration - 3                |
| Filter, Ultrafiltration - 4                |
| Holding tank                               |
| Ion exchange                               |
| Natural wetlands                           |
| pH adjustment - 1                          |
| pH adjustment - 2                          |
| pH adjustment - 3                          |
| Pond Unit - 1                              |
| Pond Unit - 2                              |
| Pond Unit - 3                              |
| Pond Unit - 4                              |
| Pond Unit - 5                              |
| Pond Unit - 6                              |
| Pond Unit - 7                              |
| Pond Unit - 8                              |
| Pond Unit - 9                              |
| Pond Unit - 10                             |
| Pond Unit - 11                             |
| Pond Unit - 12                             |

|                        |
|------------------------|
| Pond Unit - 13         |
| Pond Unit - 14         |
| Reverse osmosis        |
| Settling tank - 1      |
| Settling tank - 2      |
| Settling tank - 3      |
| Settling tank - 4      |
| Settling tank - 5      |
| Thickener - 1          |
| Thickener - 2          |
| Vacuum drum filter - 1 |
| Vacuum drum filter - 2 |
| Vacuum filter belt - 1 |
| Vacuum filter belt - 2 |
| NA                     |
| Other                  |

| Destinations                                  |
|---|
| Select  |
| Burned on site                                |
| Deep-well injection                           |
| Discharge to POTW                             |
| Discharge to PrOTW                            |
| Discharge to surface water                    |
| Evaporation                                   |
| Hauled off site for reuse (given away)        |
| Hauled off site for reuse (marketed and sold) |
| Hauled off site for reuse (removal fee)       |
| Hauled off site for disposal                  |
| Mixed with fly ash for disposal               |
| On-site company owned landfill                |
| POND-1  |
| POND-2  |
| POND-3  |
| POND-4  |
| POND-5  |
| POND-6  |
| POND-7  |
| POND-8  |
| POND-9  |
| POND-10                                       |
| POND-A  |
| POND-B  |
| POND-C  |
| Reuse as boiler water                         |
| Reuse as bottom ash sluice                    |
| Reuse as combined ash sluice                  |
| Reuse as FGD absorber makeup                  |
| Reuse as FGD slurry preparation water         |
| Reuse as fly ash sluice                       |
| Reuse as mill reject sluice                   |
| Reuse in cooling towers                       |
| WWT-1   |
| WWT-2   |



|       |
|-------|
| WWT-3 |
| WWT-4 |
| WWT-5 |
| WWT-6 |
| WWT-A |
| WWT-B |
| WWT-C |
| NA    |
| Other |

| Units  |
|--------|
| Select |
| µg/L   |
| mg/L   |