

C

10/04/06

If your annuity claim number begins with the letters "CSA", press 1. 103

If your annuity claim number begins with the letters "CSF", press 2. 104

Please enter the first 7 numbers of your annuity claim number now. Don't enter the letters CSA or CSF. 105

Your annuity claim number is..... 106

Claim number from TT entry

If this is correct, press 1. 201

If this is not correct, press 2 to reenter. 202

To leave Open Season Express, press 9. 203

valid (RC = 000)

invalid (RC = 001)

Retrieve SSN from host

The annuity claim number you entered is not on our file. 126

Increment claim error count

Check claim error count

exit

C

For security purposes, please enter the last 4 digits of your social security number now. 107

The annuity claim number you entered is not on our file. 126

Check holiday

oper

H

You entered ... 200

SSN from TT entry

If this is correct, press 1. 201

If this is not correct, press 2 to reenter. 202

To leave Open Season Express, press 9. 203

exit

Set indicator for valid CLAIM/SSN entry. RC=000

The numbers you entered do not match the numbers we have on file for the annuity claim number you entered. 108

Increment SSN error count

Check SSN error count

I

Please enter your daytime telephone number, including area code using your telephone keypad followed by the pound sign. 263

RC=000, but Annuitant Type 3, 5, or 6

Check holiday

Yes -> H

oper

You entered ... 200

Entry from caller

If this is correct, press 1. 201

If this is not correct, press 2 to re-enter. 202

FF Check saved menu request. RC=000

Invalid annuity claim number entered. Press 1 to continue. Press 2 to re-enter. Press 9 to leave Open Season Express. OPMVT 10/03/03

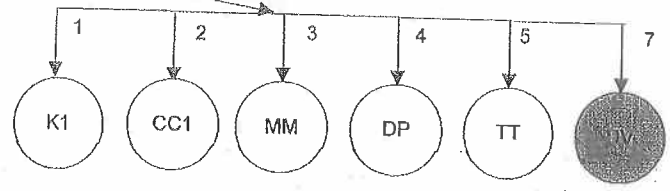

Enrollment Requests

10/04/06

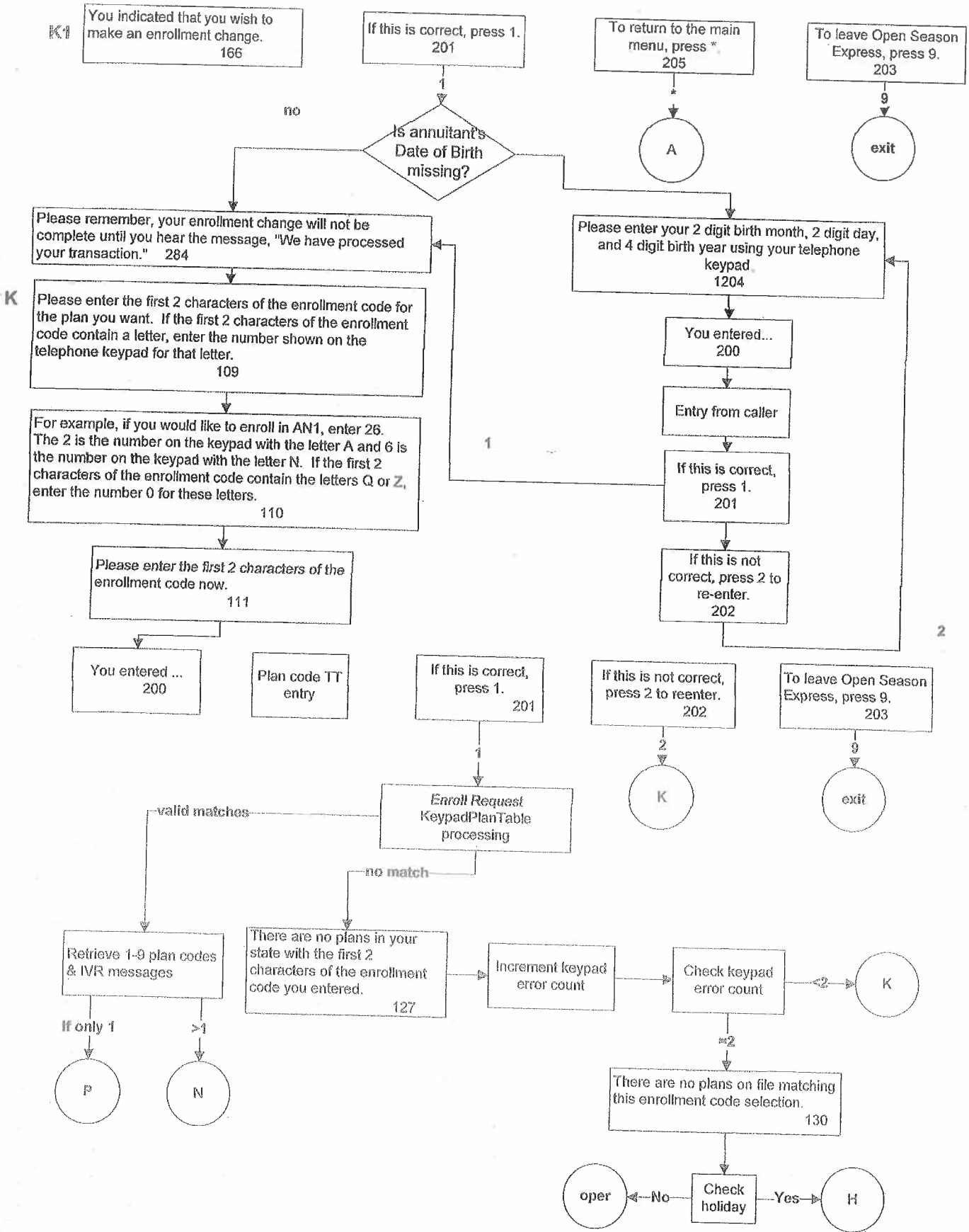

Enrollment Requests

10/04/06

P

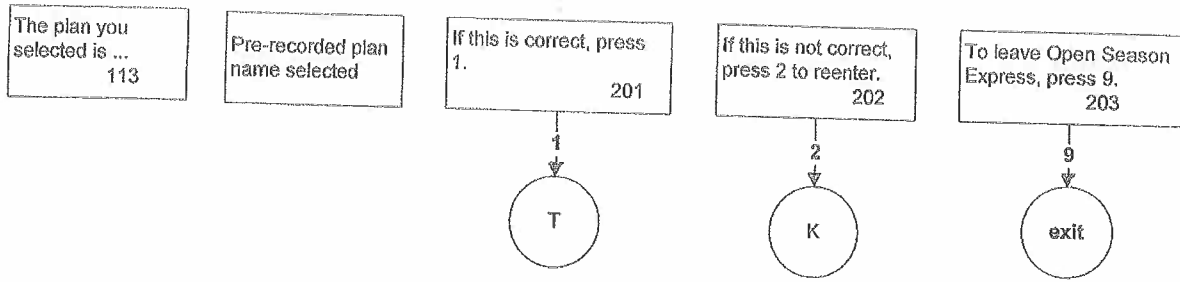

N

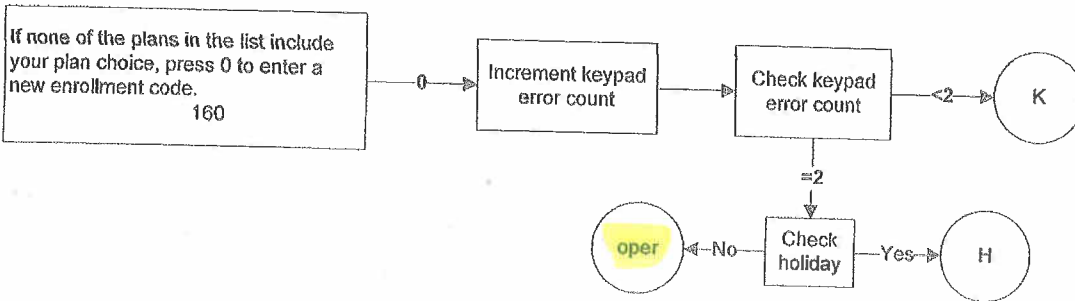
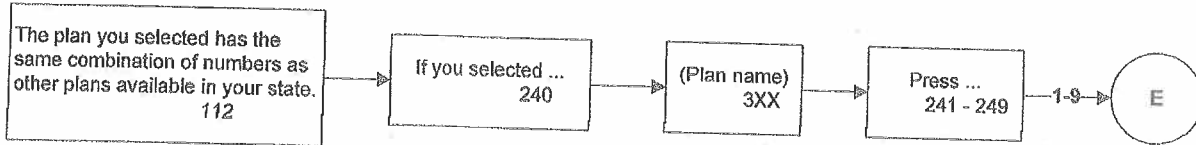

E

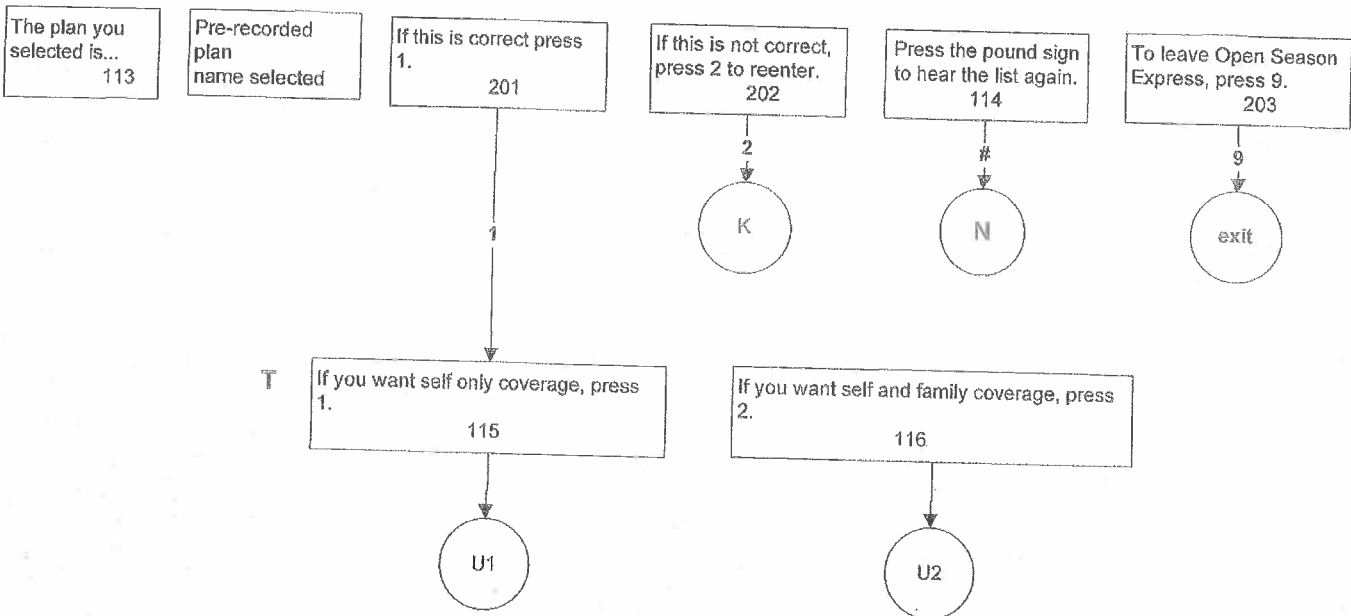

Enrollment Requests
self only

10/04/06

U1

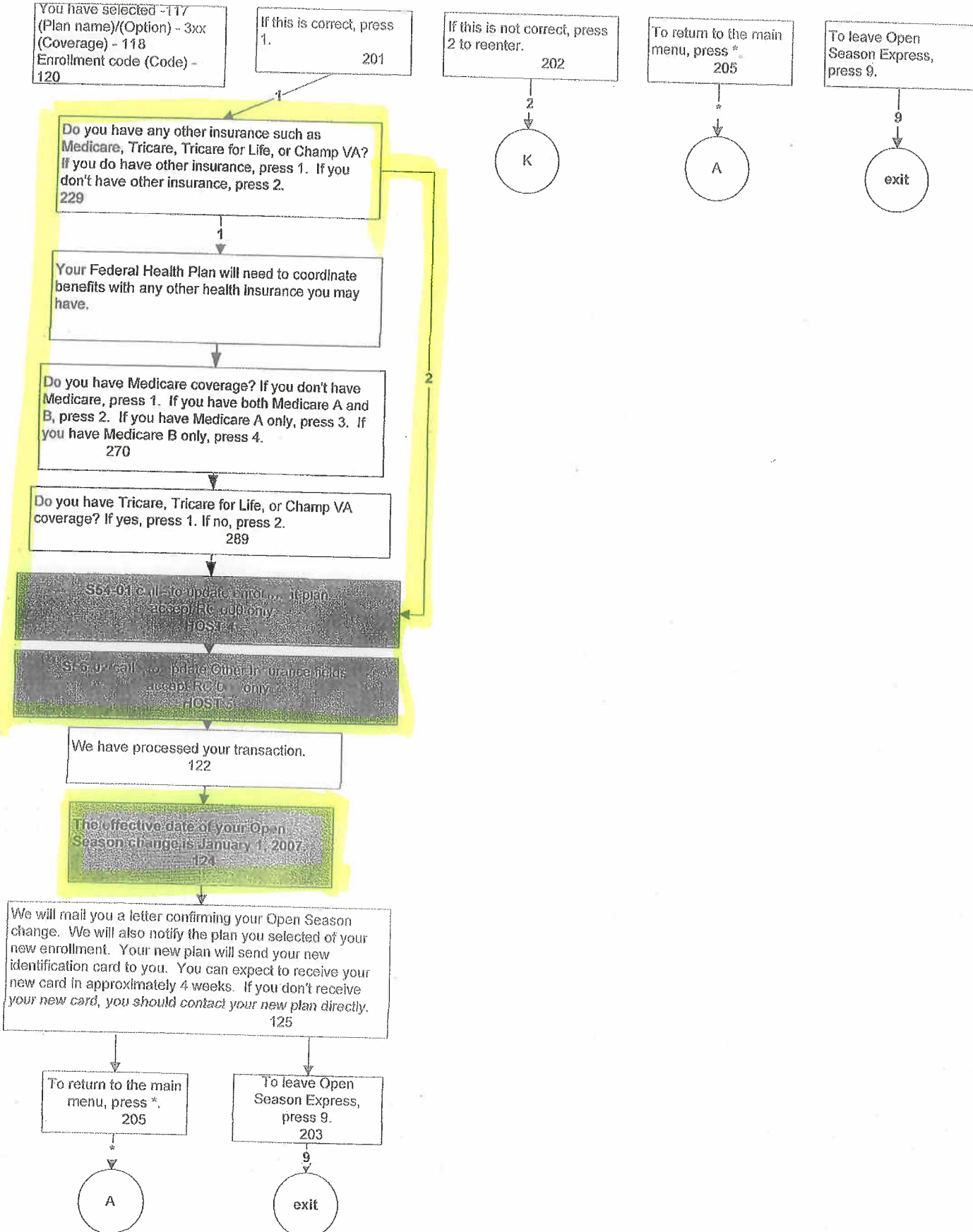

Enrollment Requests self & family

10/04/06

U2

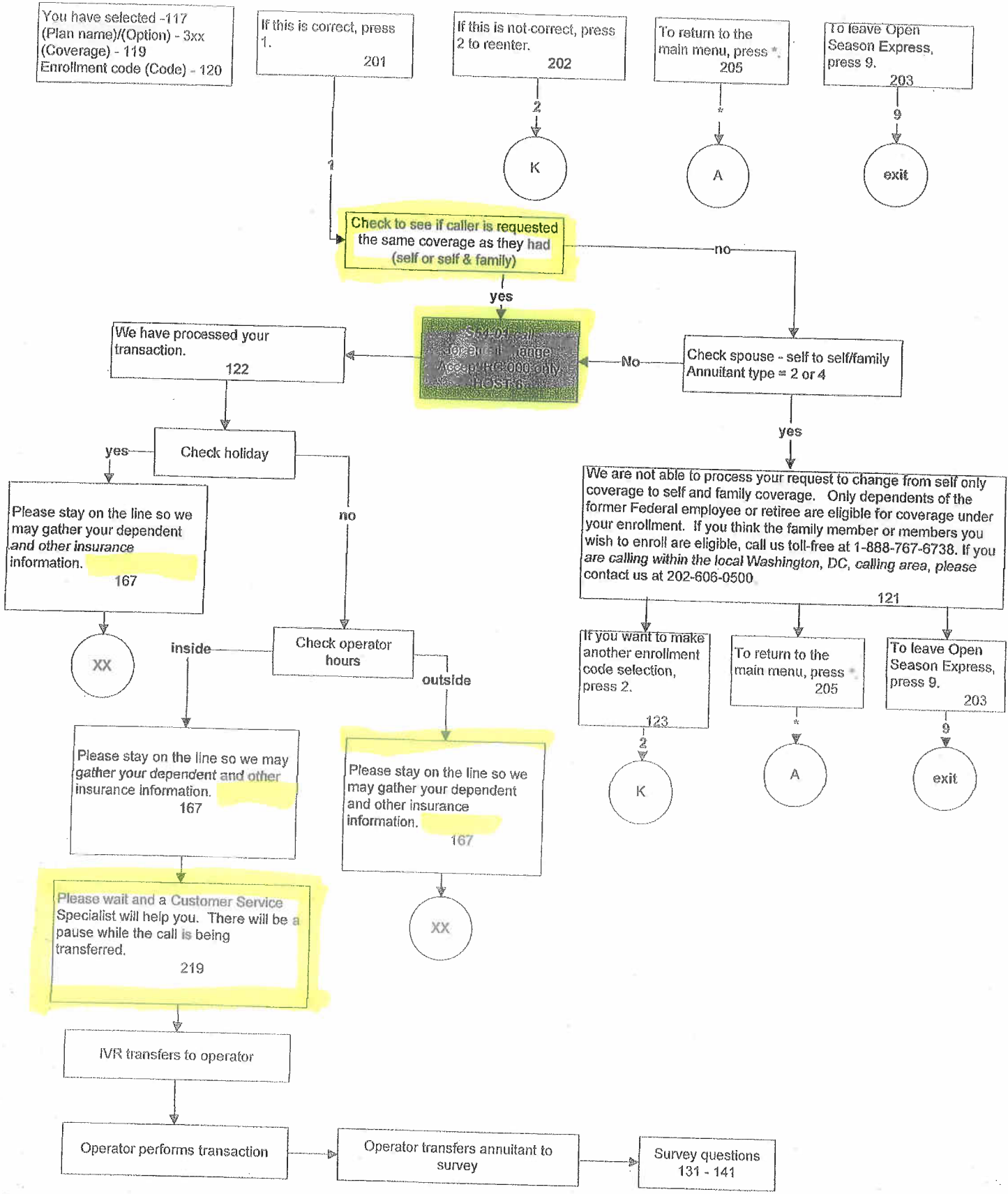

Brochure Requests

10/04/06

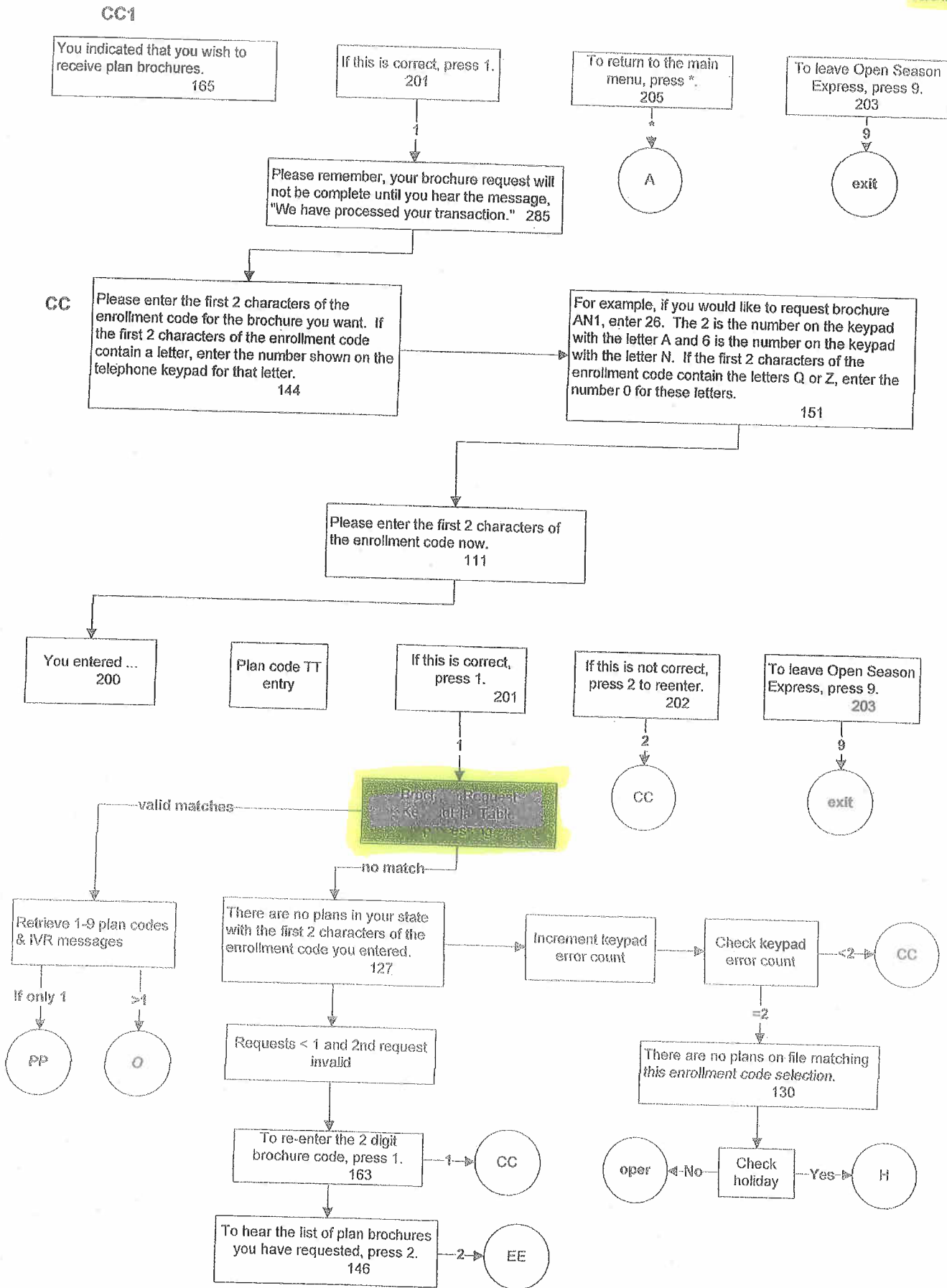

Brochure Requests

10/04/06

PP

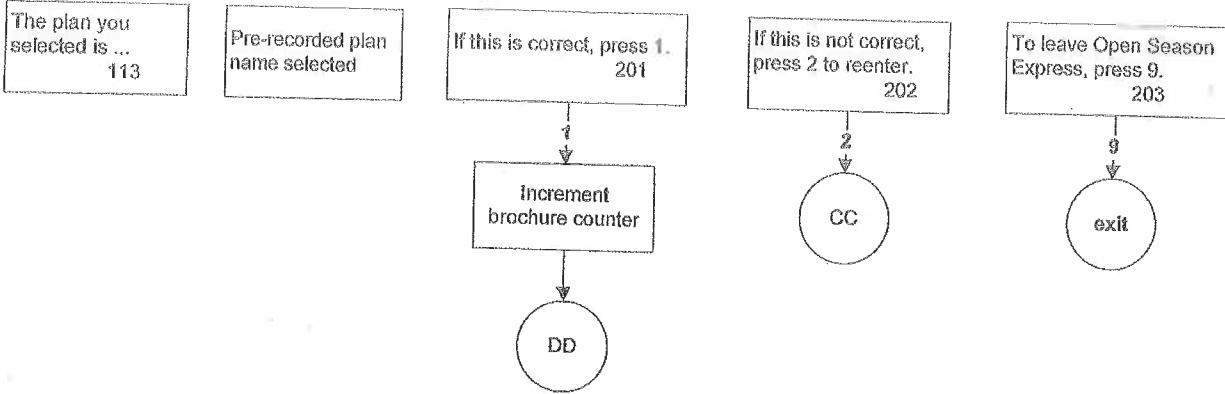

O

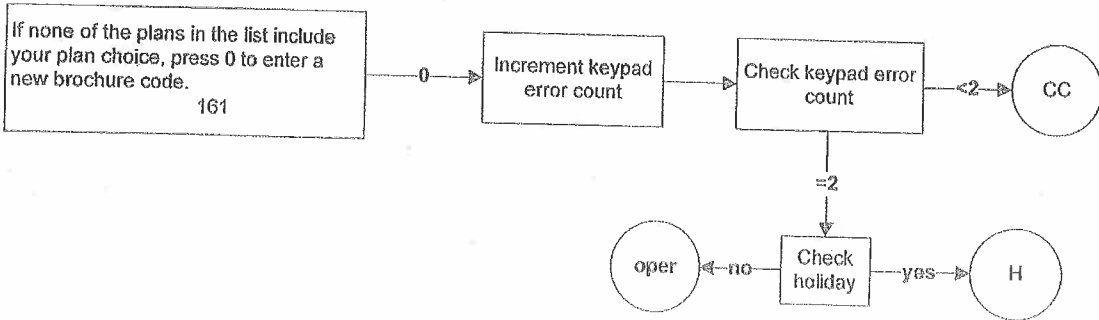
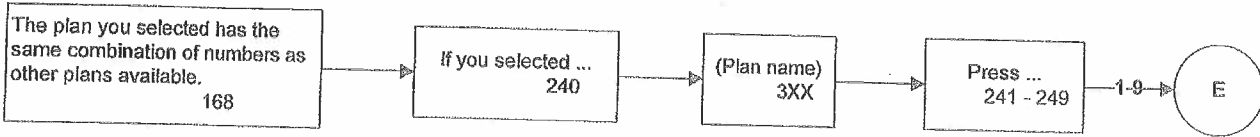

E

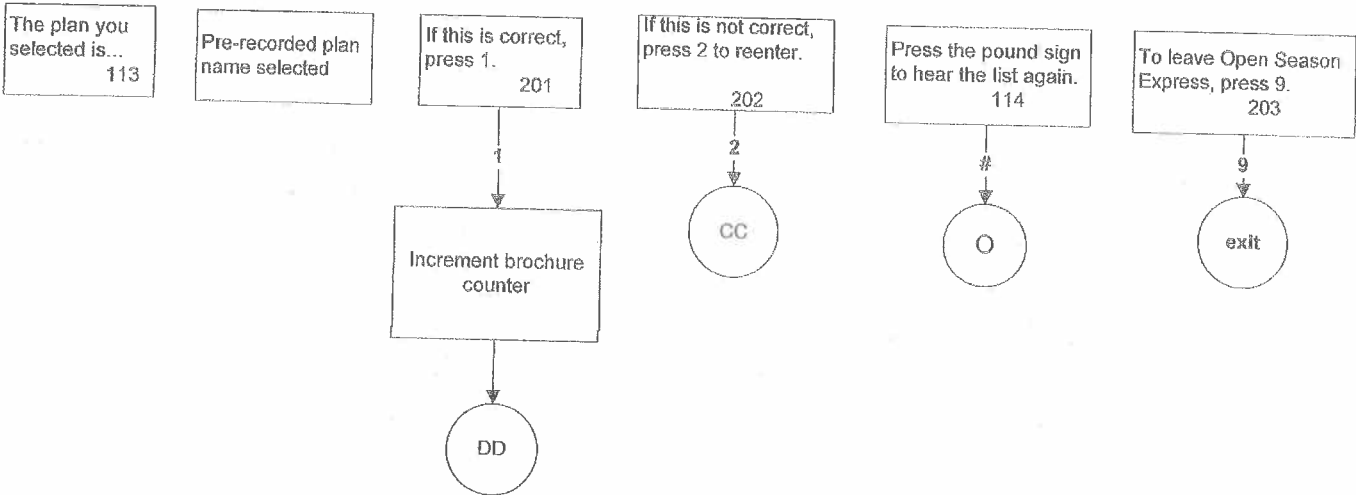

Brochure Requests

10/04/06

DD

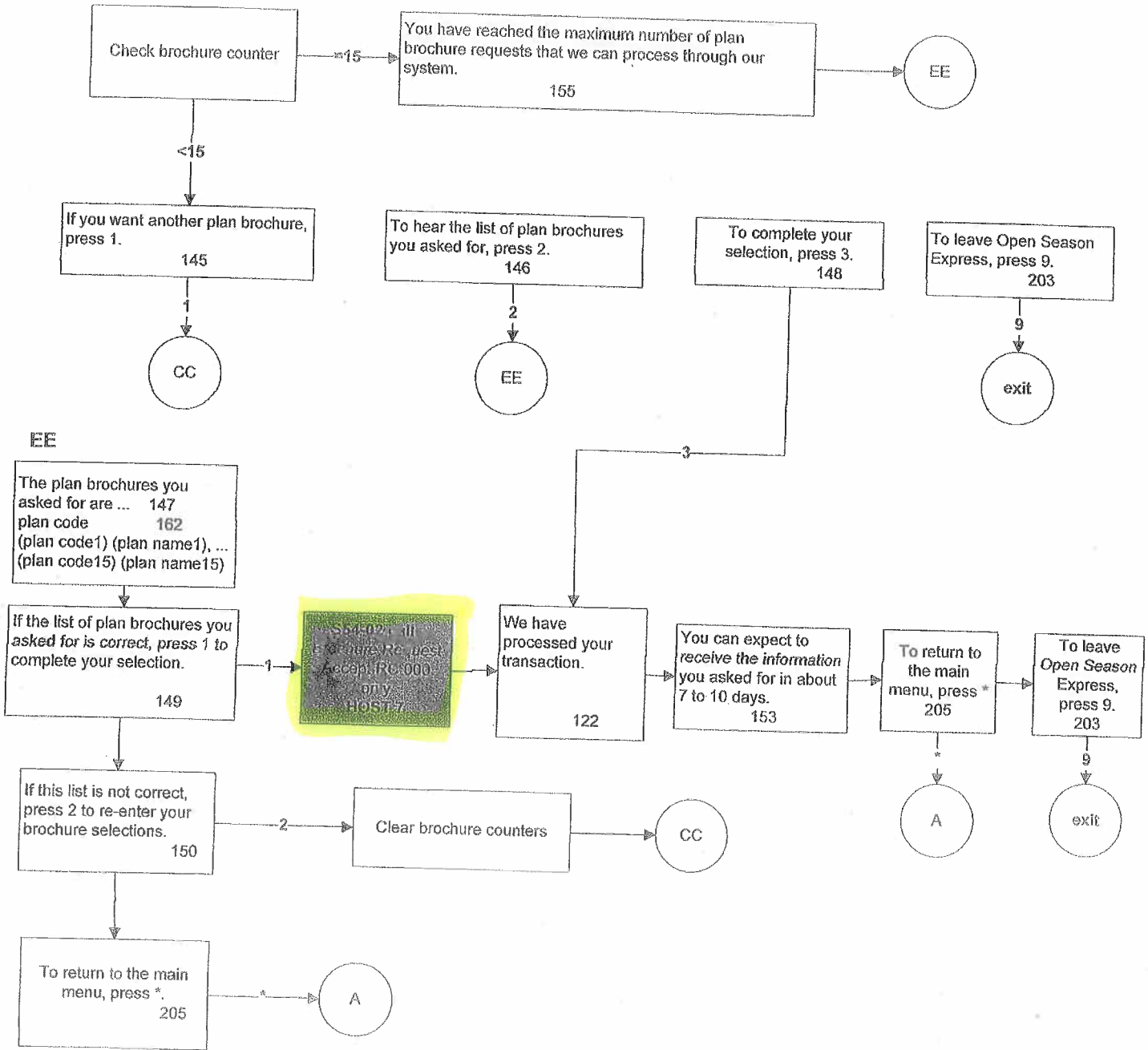

EE

Premiums to OPM

10/04/06

DP

You indicated that you wish to receive information on how to pay your premiums directly to us. Please note this option is only available when your *monthly annuity payment is not large enough to cover the cost of the monthly health benefits premium.*
156

If this is correct, press 1
201

To return to the main menu,
press *.
205

To leave Open Season
Express, press 9.
203

5-415-Call DirectPay info
Require
Approved RC 000- only
HOSTID:

A

exit

We have processed your
transaction.
122

You can expect to receive the
information you asked for in about 7 to
10 days.
153

To return to the main menu,
press *.
205

To leave Open Season Express,
press 9.
203

A

Survey questions
131 - 141

Thank you for using Open
Season Express.
204

Suspend/Cancel

10/04/06

MM

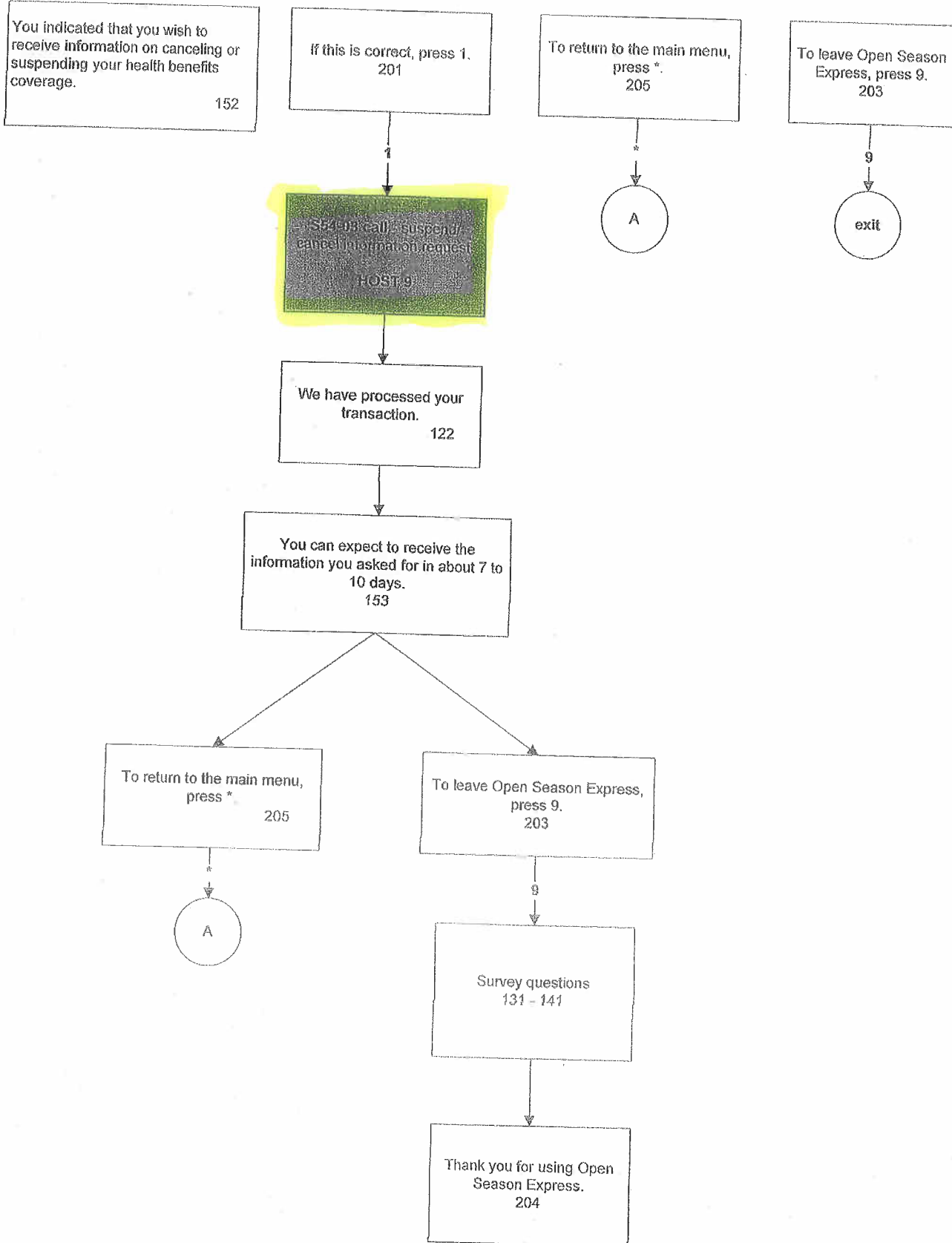

Health Plan Survey

10/04/06

TT

You indicated that you wish to receive plan accreditation and survey information on how FEHB members rated their health plans.
157

If this is correct, press 1.
201

To return to the main menu, press *.
205

To leave Open Season Express, press 9.
203

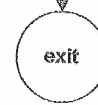

We have processed your transaction.
122

You can expect to receive the information you asked for in about 7 to 10 days.
153

To return to the main menu, press *.
205

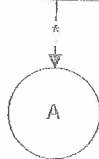

To leave Open Season Express, press 9.
203

Survey questions
131 - 141

Thank you for using Open Season Express.
204

DV

... that you wish to
... forms ... available
... and costs for federal
employees' Dental and Vision
Insurance Program.

If this is correct, press 1.
201

To return to the main menu,
press *.
205

To leave Open Season
Express, press 9.
203

... call FEDVIP
... request
Acceptance only.
HOST 1

A

exit

We have processed your
transaction.
122

You can expect to receive the
information you asked for in about 7 to
10 days.
153

To return to the main menu,
press *.
205

To leave Open Season Express,
press 9.
203

A

Survey questions
131 - 141

Thank you for using Open
Season Express.
204

Federal Holiday

10/04/06

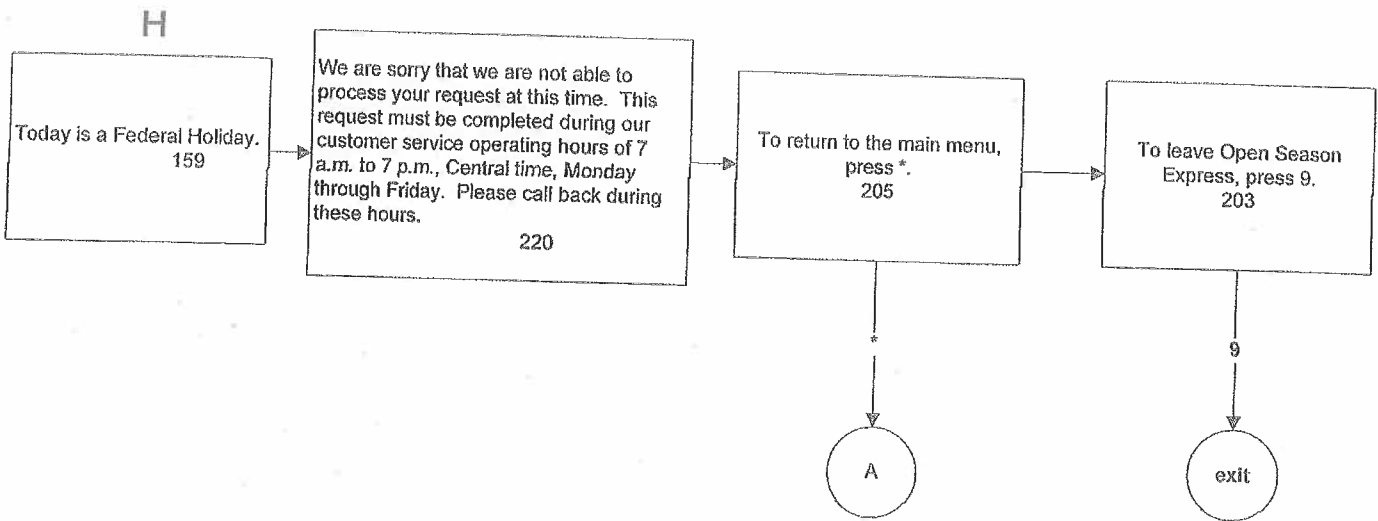

Address Change

10/04/06

RR

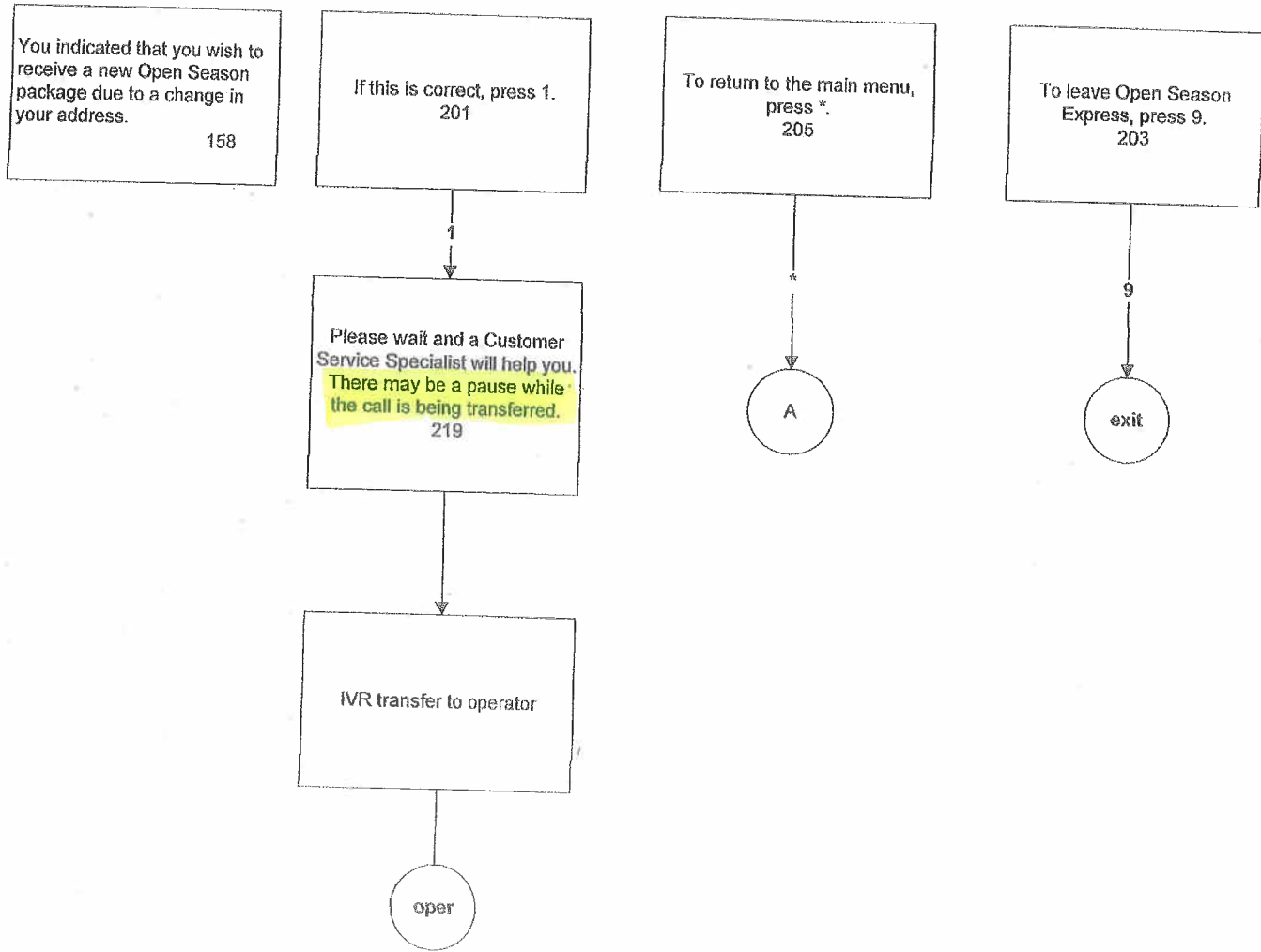

Transfer to operator

10/04/06

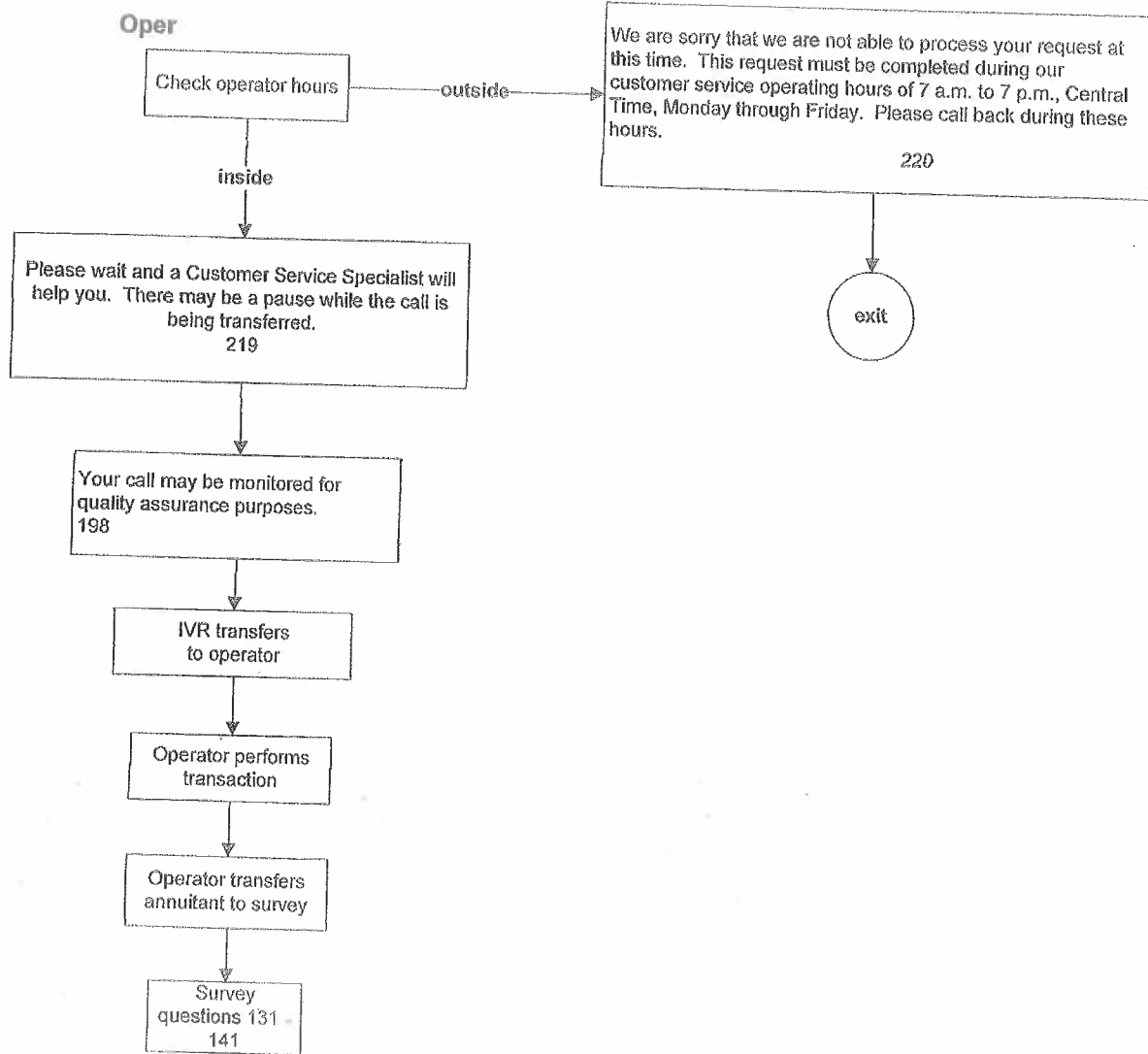

Exit Routine

10/04/06

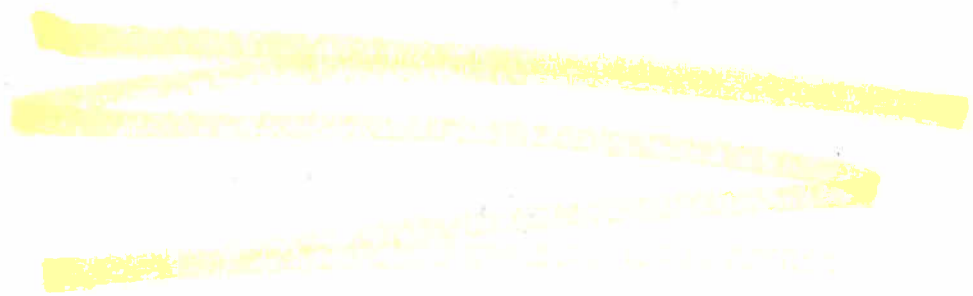
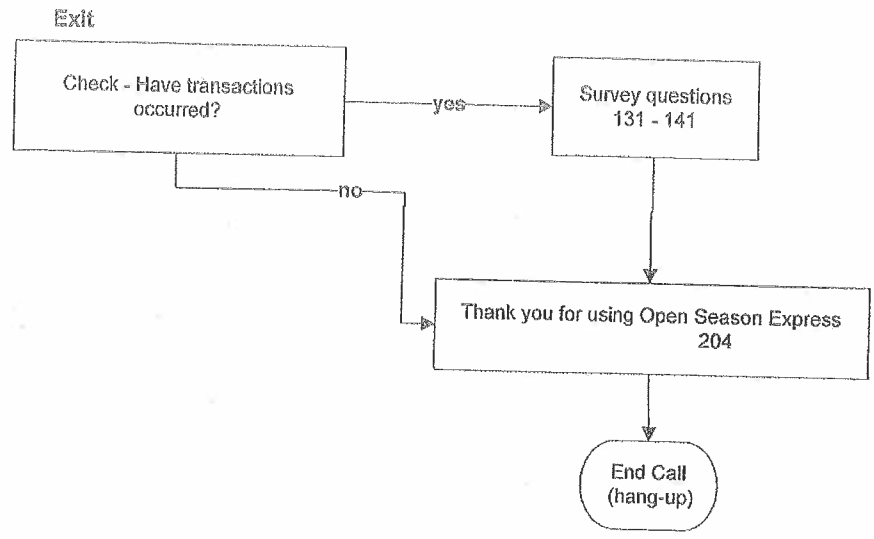

Transcription Box

10/04/06

XX

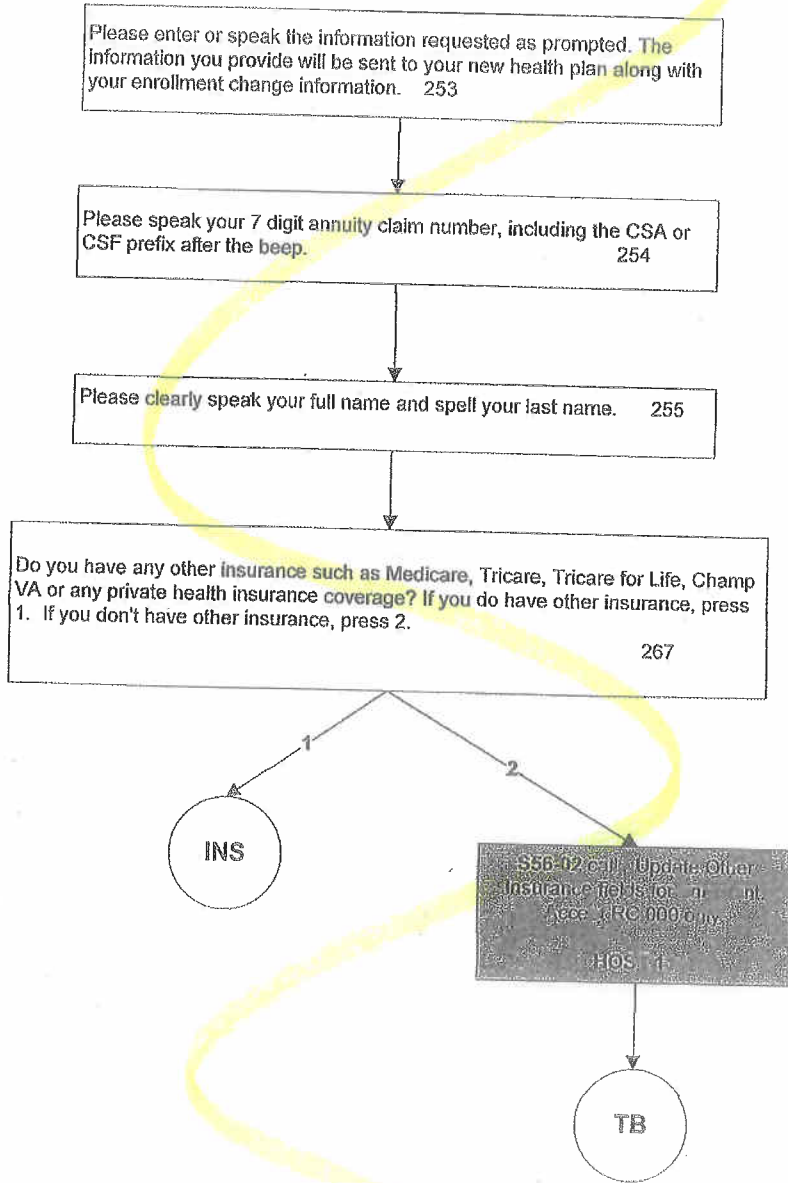

Transcription Box
Dependent Information

10/04/06

TB

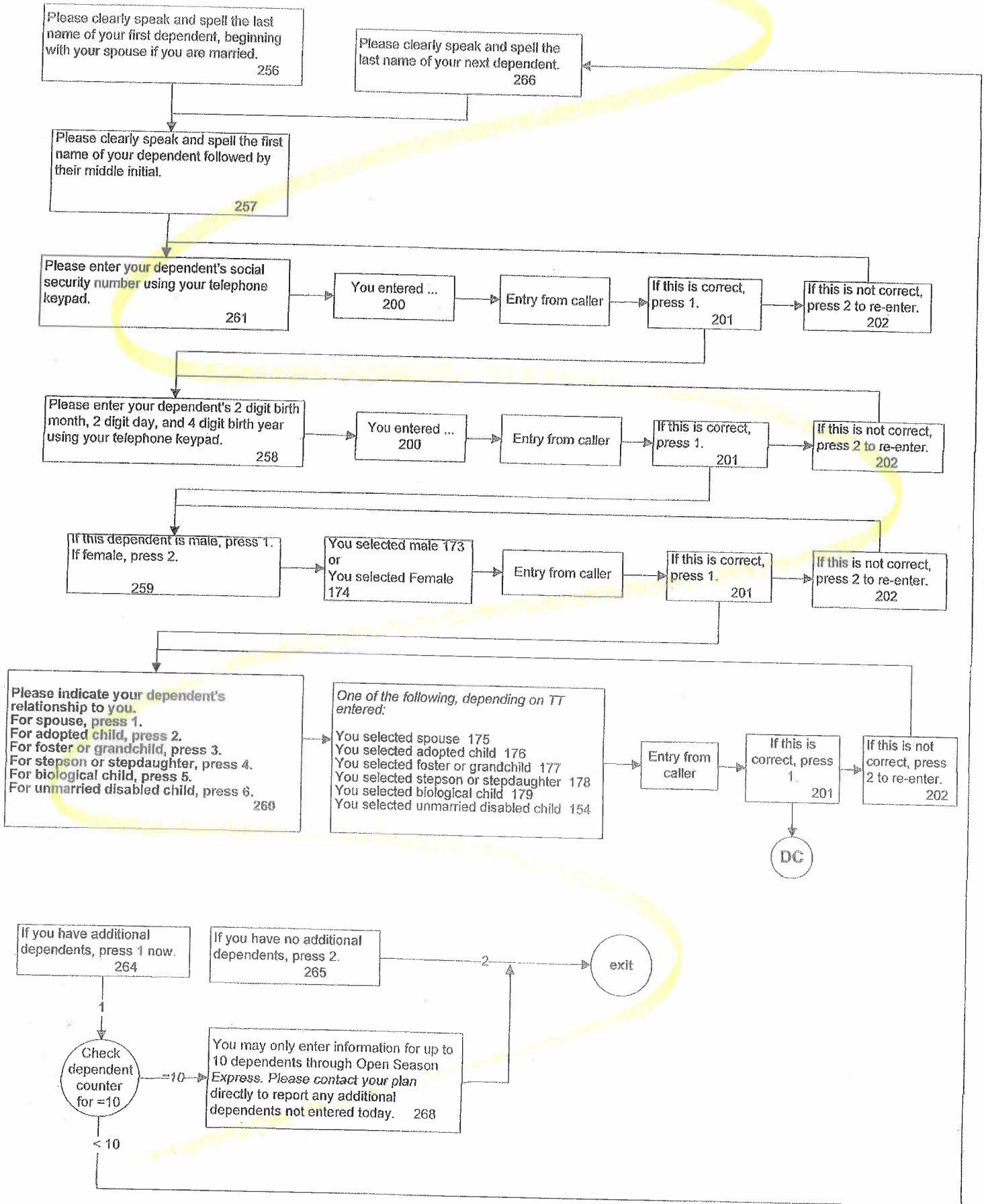

Transcription Box
Other Insurance

10/04/06

Ins

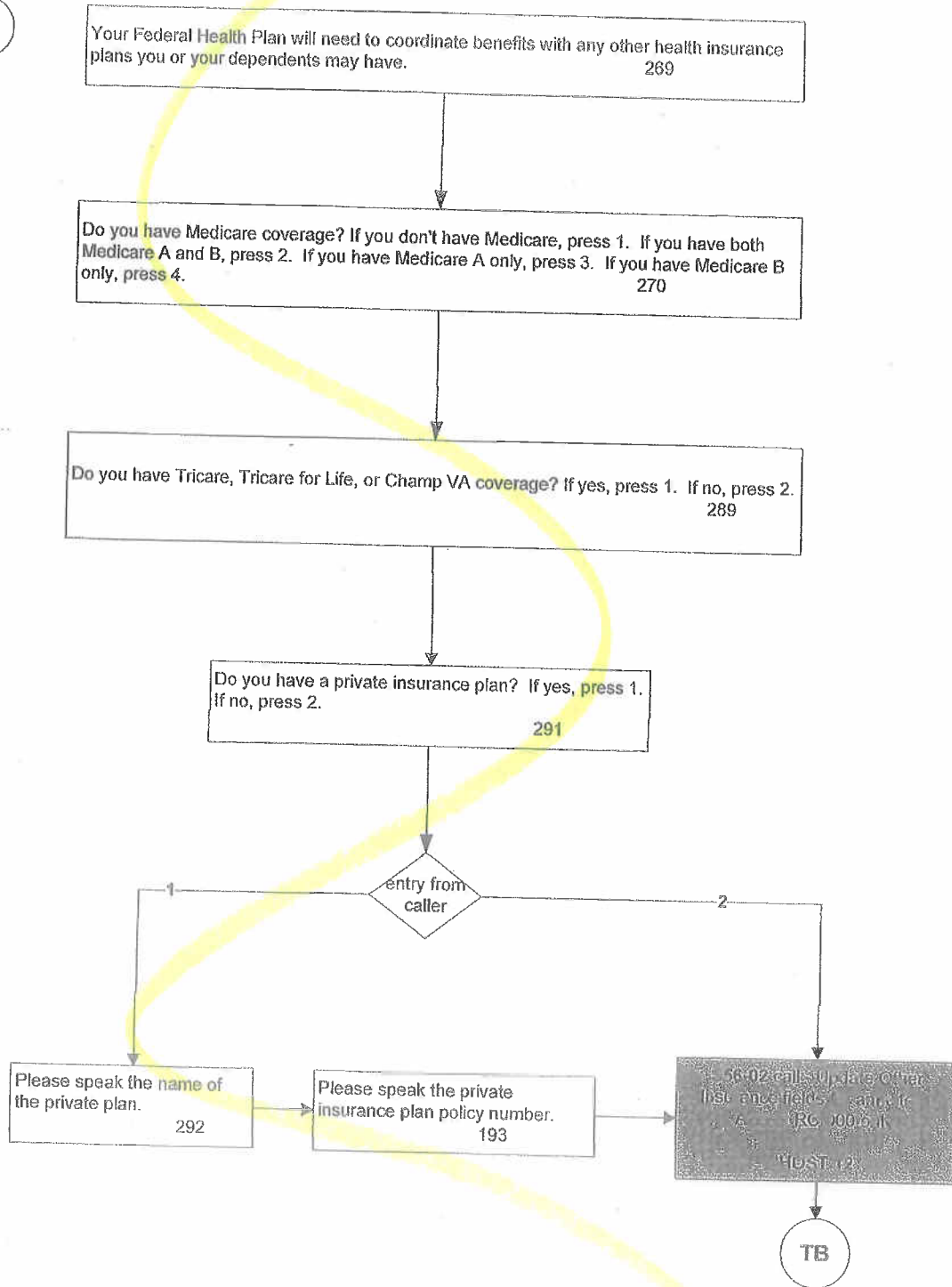

Transcription Box
Dependent Other
Insurance

10/04/06

Dep
Ins

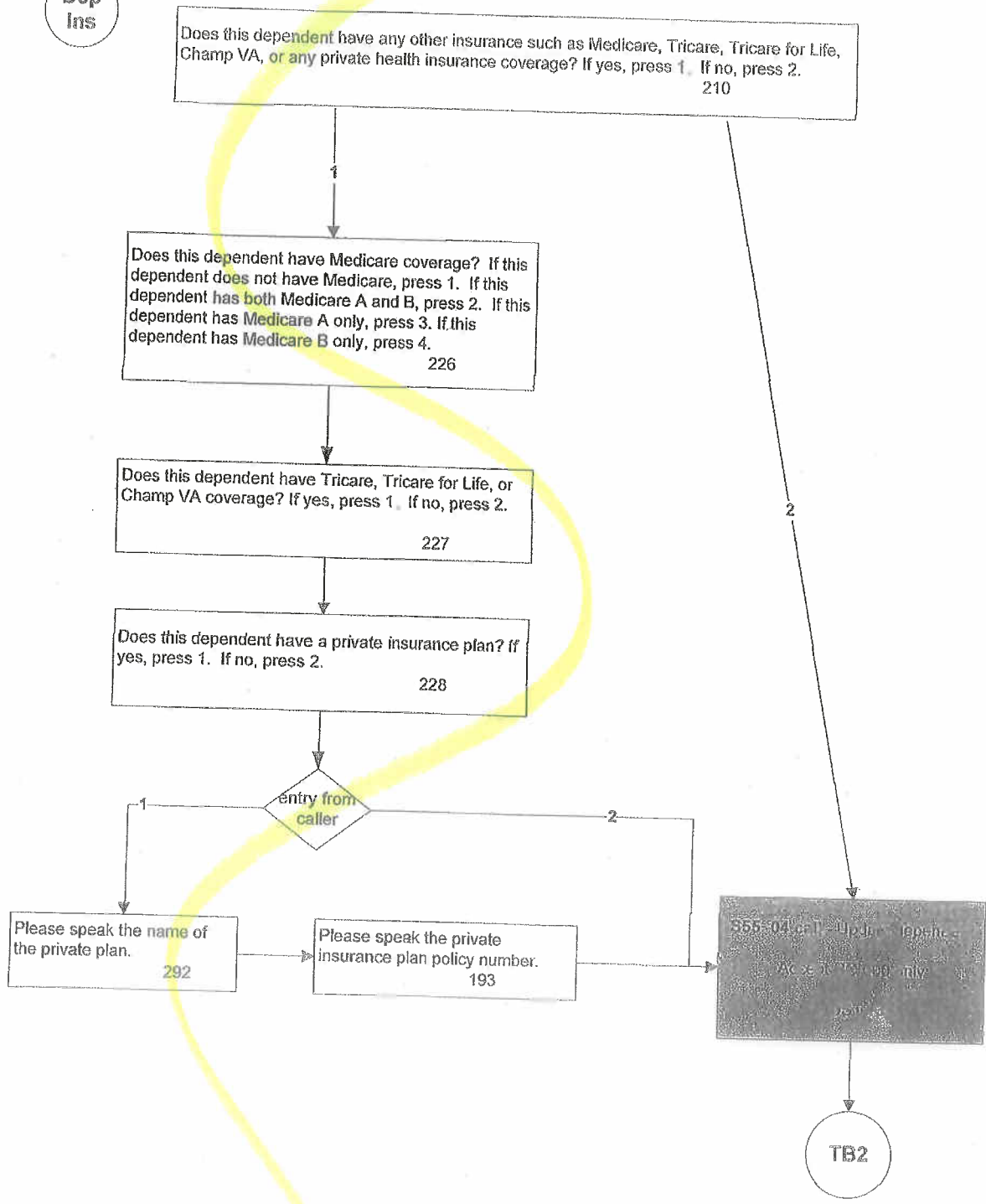

Survey Questions

Your opinion about this system is very important to us. In our efforts to better serve you we ask that you stay on the line and answer a few short questions that will take less than a minute to answer. Your participation will help us improve our customer service. 131

Question #1

Were the open season materials we sent you easy to read and understand?
132

If you found the materials easy to read and understand, press 1. If you found the materials difficult to read and understand, press 2. If you found no difference from previous years, press 3. 133

Question #2

Was our automated Open Season Express system easy to use?
134

If the system was easy, press 1. If the system was difficult, press 2. If you found no difference from previous years, press 3. 135

Question #3

Do you have access to the internet?
136

If you have access to the Internet, press 1. If you don't have access to the Internet, press 2. 137

Question #4

Overall, how would you rate Open Season Express?
140

For good, press 1. For fair, press 2. For poor, press 3. 141

Check extension to see if call came from operator

NO

Write Survey File
Execute Process #25
file: survresp.txt

End Call

YES
Ext 3012

Question #5

In general, how courteous was the Customer Service Specialist during this call?
138

For courteous, press 1. For discourteous, press 2. If you have no opinion, press 3. 139

Write Survey File
Execute Process #50
file: survoper.txt

End Call

SPANISH

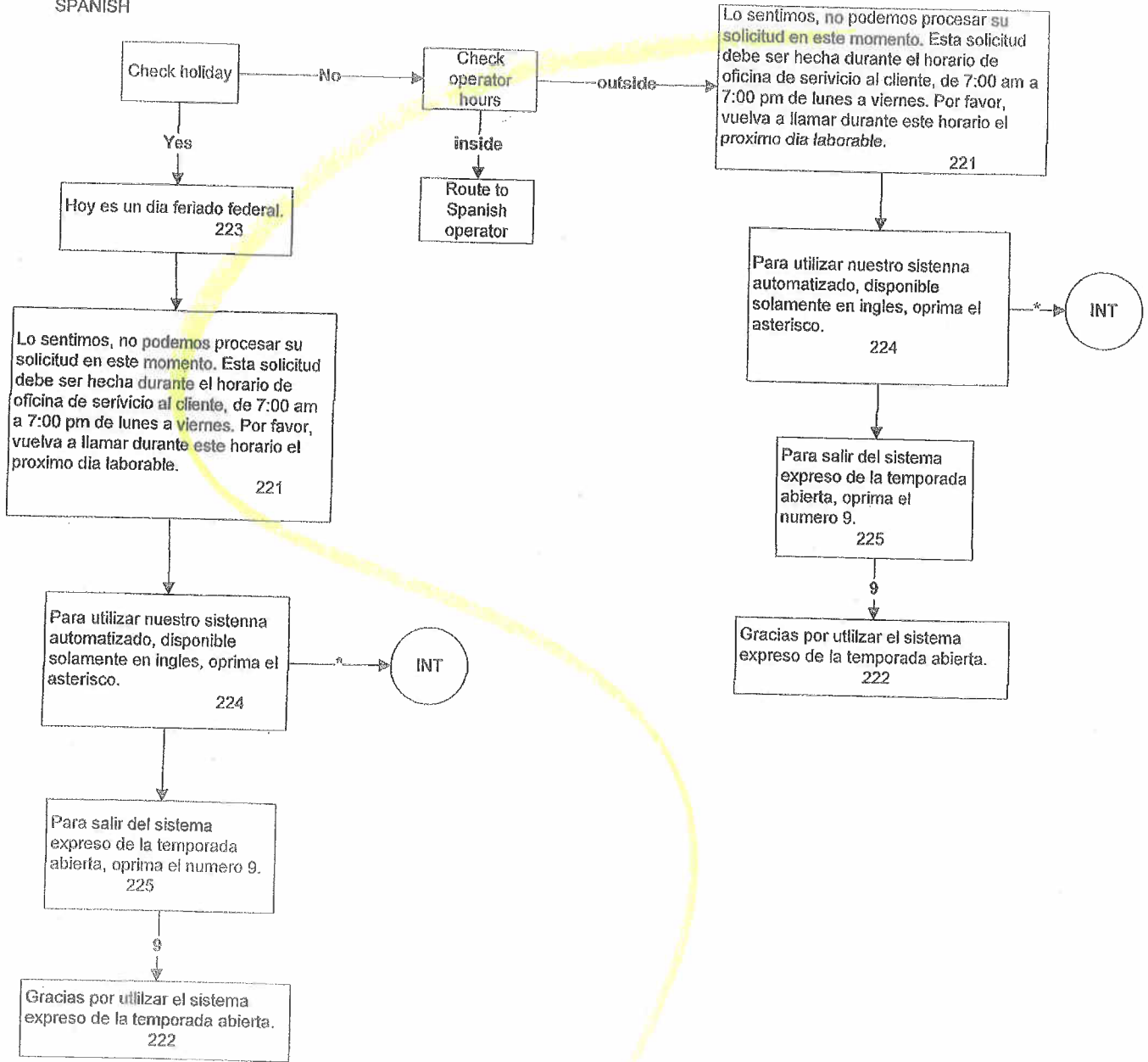

DEPENDENT CHECKS

10/04/06

DC

