

Rural Broadband Access Loan and Loan Guarantee Program

Application Guide—RUS Bulletin 1738-1



According to the Paperwork Reduction Act of 1995, an agency may not conduct or sponsor, and a person is not required to respond to, a collection of information unless it displays a valid OMB control number. The valid OMB control number for this information collection is 0572-0130. The time required to complete this information collection is estimated to average 118 hours per response, including the time for reviewing instructions, searching existing data sources, gathering and maintaining the data needed, and completing and reviewing the collection of information.

**Rural Utilities Service (RUS)
Telecommunications Program
Rural Broadband Access Loan and Loan Guarantee
Program**

The Rural Broadband Access Loan and Loan Guarantee Program (Broadband Program) furnishes loans and loan guarantees to provide funds for the costs of construction, improvement, or acquisition of facilities and equipment needed to provide service at the broadband lending speed in eligible rural areas.

!! BEFORE GETTING STARTED !!

The applicant must read:

- ◆ ***The latest Notice of Funds Availability (NOFA) published in the Federal Register; and***
- ◆ ***The latest version of 7 CFR 1738 – Rural Broadband Access Loans and Loan Guarantees.***

These documents **MUST** be utilized in conjunction with this Application Guide. Should any differences result in the interpretation of this Application Guide and the Regulation, the Regulation takes precedence over information contained in this Application Guide.

In addition, all construction financed with RUS Telecommunications Program loan funds must be done in accordance with RUS Bulletin 1738-2, Rural Broadband Access Loan and Loan Guarantee Program, Advance and Construction Procedures Guide.

The above documents can be retrieved from our web site or from any of RUS' General Field Representatives (GFRs) for the Telecommunications Program.

http://www.rurdev.usda.gov/utp_farmbill.html

Application Guide Table of Contents

General Information.....	5
1. Broadband Service and Broadband Lending Speed.....	5
2. Eligible Purposes of the Loan.....	6
3. Ineligible Purposes of the Loan.....	7
4. Applicant Eligibility.....	8
5. Eligible Service Area.....	8
6. Substantially Underserved Trust Areas	10
7. Preliminary Assessment of Service Area Eligability.....	11

8. Types of Broadband Loans.....	11
9. Minimum and Maximum Loan Amounts.....	12
10. Equity Requirement.....	12
11. Priority Consideration.....	13
12. Public Notice.....	13
13. Application Submission.....	14
14. Application Review and Notification Process.....	15
15. Contact Information.....	16
Instructions for Completing the RUS Form 532.....	18
Overview to Preparing Schedules A through S.....	21
Instructions for Preparing Schedules A & B.....	21
Congressional Districts (Schedule A).....	21
Executive Summary (Schedule B).....	21
Instructions for Preparing Schedule C.....	22
Legal Opinion and Property Schedule (Schedules C-1 and C-2).....	22
Instructions for Preparing Schedules D & E.....	22
Corporate Structure (Schedules D-1 through D-6).....	22
Board Resolution (Schedule E).....	26
Instructions for Preparing Schedule F.....	26
Service Area Maps and Demographic Data (Schedules F-1 and F-2).....	26
Instructions for Preparing Schedule G.....	27
Service Areas – New or Existing; Funded or Non-Funded (Schedule G).....	28
Instructions for Preparing Schedules H, I & J.....	28
Compliance Certificates (Schedules H-1 through H-6).....	28
Outstanding Federal Debt (Schedule I).....	29
Equity (Schedules J-1 and J-2).....	29
Instructions for Preparing Schedule K.....	30
Research Data and Market Analysis (Schedules K-1 and K-2).....	30
Instructions for Preparing Schedule L.....	33
Competitive Analysis (Schedules L-1 and L-2).....	33
Instructions for Preparing Schedule M.....	34
Financial Position (Schedules M-1 through M-6).....	34
Instructions for Preparing Schedule N.....	54
Network Design (Schedules N-1 through N-3).....	54
Instructions for Preparing Schedule O.....	58
Network Diagrams (Schedules O-1 and O-2).....	58

Instructions for Preparing Schedule P	60
Project Costs and Buildout Timeline (Schedule P).....	60
Instructions for Preparing Schedules Q & R	62
Environmental Report (Schedule Q).....	62
Licenses and Agreements (Schedule R).....	63
Attachment: USOA Account Subcategories for Broadband Service Providers.....	66
Appendix: Sample Network Diagrams	75

General Information

➤ 1. *Broadband Service and Broadband Lending Speed*

The goal of the Broadband Program is to ensure that rural consumers enjoy the same quality and range of services that are available in urban and suburban communities. This Program aims to lend to entities capable of repaying its loans and that plan to offer service at a level that keeps pace with technological innovations while meeting the demands of customers in rural America. Applicants are strongly encouraged to ensure they understand the terminology below, which seeks to make this distinction.

Broadband service means any technology identified by the Administrator as having the capacity to provide transmission facilities that enable the subscriber to the service to originate and receive high-quality voice, data, graphics, and video. RUS will publish, in a notice in the Federal Register, the minimum rate of data transmission that will qualify as broadband service. This rate may be different for fixed and mobile broadband service. The minimum rate of data transmission that defines broadband service may be different than the broadband lending speed. If a new minimum rate of data transmission for broadband service is published in the Federal Register while an application is pending, broadband service for the purpose of reviewing the application will be defined by the minimum rate of data transmission that was required at the time the application was received by RUS.

The broadband lending speed is the minimum bandwidth requirement, as published in the latest notice in the Federal Register, that an applicant must propose to deliver to every customer in the proposed funded service area in order for RUS to approve a broadband loan. This rate may be different for fixed and mobile broadband service. As noted above, the broadband lending speed may be different from the minimum rate of data transmission required to determine the availability of broadband service when qualifying a service area. If a new broadband lending speed is published in the Federal Register while an application is pending, the pending application will be returned unless the proposed broadband system can provide service at the new broadband lending speed. Returned applications will lose their place in the processing queue.

When RUS evaluates a service area's eligibility to receive funding based on the broadband lending speed, it takes into account the following principles:

- No part of the funded service area can overlap with the service area of a current RUS borrower or grantee, in which a) they are providing broadband service or b) have a loan or grant from RUS to provide broadband service and are within their approved construction schedules.
- After the publication of a new broadband lending speed in the Federal Register, RUS will not provide funding for any service area that overlaps with an RUS borrower or grantee for 24 months from the date on which the new broadband lending speed was published.

- For borrowers that are in the build-out period when a new broadband lending speed is published, the 24 month protection period will begin at the end of the build-out period.
- After the 24 month period of protection, RUS may consider a loan in an area for which there is a current RUS borrower or grantee if the service provided does not meet the new broadband lending speed.
- For borrowers and grantees that fail to upgrade their services to the broadband lending speed during the 24 month protection period, publication of a subsequent broadband lending speed does not trigger a new 24 month protection period.

➤ ***2. Eligible Purposes of the Loan***

RUS makes broadband loans and loan guarantees to:

- ◆ Finance the construction, improvement, and acquisition of all facilities required to provide service at the broadband lending speed in eligible rural areas, including facilities required for providing other services over the same facilities;
- ◆ Finance the cost of leasing facilities that are required to provide service at the broadband lending speed if the lease qualifies as a capital lease under Generally Acceptable Accounting Procedures (GAAP). The financing of such a lease will be limited to the first three years of the loan amortization period;
- ◆ Finance the acquisition of facilities, portions of an existing system and/or another company by an eligible entity, where acquisition is used in the applicant's business plan for furnishing or improving service at the broadband lending speed (please note that the acquired service area, if any, must meet the requirements for RUS funding, the acquisition costs cannot exceed 50 percent of the broadband loan amount, and the purchase must provide the applicant with a controlling majority interest in the equity acquired);
- ◆ Refinance an outstanding obligation on another telecommunications loan made under the Rural Electrification Act of 1936, as long as refinancing the loan supports the construction, improvement, or acquisition of facilities and equipment for the provision of service at the broadband lending speed in rural areas. Please note that no more than 40 percent of the broadband loan amount can be used to refinance the outstanding telecommunications loan, the applicant must be current with payments on the loan(s) to be refinanced, and the amortization period for that portion of the broadband loan that will be needed for refinancing cannot exceed the remaining amortization period for the telecommunications loan(s) to be refinanced. If multiple notes are being refinanced, an average remaining amortization period will be calculated based on the weighted dollar average of the notes being refinanced; and

- ◆ Finance pre-loan expenses, i.e. any expenses associated with the preparation of a loan application, such as obtaining market surveys, accountant/consultant costs for preparing the application and supporting information. The pre-loan expenses cannot exceed 5 percent of the broadband loan excluding any amount requested to refinance outstanding telecommunication loans. Please note that pre-loan expenses may be reimbursed only if they are incurred prior to the date on which notification of a complete application is issued.

➤ ***3. Ineligible Purposes of the Loan***

RUS will not make a broadband loan or loan guarantee for the following purposes:

- ◆ To fund operating expenses of the applicant;
- ◆ To fund construction and other project-related costs incurred prior to issuance of an application complete status (with the exception of eligible pre-loan expenses);
- ◆ To finance the acquisition of any stock of an affiliate of the applicant;
- ◆ To finance the purchase or acquisition of any facilities or equipment of an affiliate, unless approved by RUS in writing (such a purchase or acquisition may be approved if the applicant demonstrates that the purchase or acquisition will involve an arms-length transaction, as defined in 7 CFR 1738.2, and that the cost is advantageous for the applicant);
- ◆ To finance the purchase of Customer Premises Equipment (CPE) and the installation of associated inside wiring unless that CPE is (a) owned by the applicant throughout its economic life; or (b) backed by acceptable collateral that is not currently owned by the applicant and that has a value at least equal to the purchase price of the CPE (such collateral may not be purchased with RUS loan funds); or (c) paid for through a revolving fund whereby the proceeds from CPE sold to the customer (at least the applicant's cost of the equipment) is returned to the fund and used to purchase additional CPE.
- ◆ To fund the purchase or lease of any vehicles not used primarily in construction or system improvements;
- ◆ To fund the cost of systems or facilities that have not been designed and constructed in accordance with the loan contract and other applicable requirements;
- ◆ To fund facilities leased under the terms of an operating lease; and
- ◆ To fund merger or consolidation of entities.

➤ ***4. Applicant Eligibility***

RUS makes broadband loans and loan guarantees to legally organized entities providing, or proposing to provide, services in eligible rural areas.

Eligible entities may be either a nonprofit or for-profit organization, and must take one of the following forms: corporation; limited liability company (LLC); cooperative or mutual organization; Indian tribe or tribal organization as defined in 25 U.S.C. 450b; or State or local government, including any agency, subdivision or instrumentality thereof. Individuals or partnerships are not eligible entities.

To be eligible to receive a loan under this program, the entity must:

- ◆ Have sufficient authority to enter into a contract with RUS;
- ◆ Submit a loan application which meets the requirements published in 7 CFR 1738 and any additional requirements published in the Federal Register;
- ◆ Agree to complete the build-out of the broadband system described in the loan application within three years from the date the borrower is notified that loan funds are available. The loan application must demonstrate that all proposed construction be completed within this three year period with the exception of CPE. CPE can be funded throughout the forecast period;;
- ◆ Demonstrate an ability to furnish, improve, or extend service at the broadband lending speed in rural areas;
- ◆ Demonstrate an equity position equal to at least 10 percent of the amount of the loan requested in the application (see Section 10 of the Application Guide for more information on the Equity Requirement); and
- ◆ Provide additional security if it is necessary to ensure financial feasibility (see § 1738.208) as determined by the Administrator.

➤ **5. Eligible Service Area**

Applications to the Broadband Loan Program must include at least one service area that is eligible for RUS funding, i.e. a funded service area. By regulatory definition, a “funded service area” is the geographic area within which an applicant proposes to offer service at the broadband lending speed using broadband loan funds. A “service area” is a geographic area within which a service provider offers telecommunications service.

The eligibility criteria are provided below:

A. Rural Areas

Only a service area completely contained within a rural area, or composed of multiple rural areas, is eligible for a broadband loan. Under this Program, a rural area is any area located in the United States, its territories and insular possessions (including any area within the Federated States of Micronesia, the Republic of the Marshall Islands, and the Republic of Palau), which according to the latest decennial census of the Bureau of the Census:

1. is not located within a city, town, or incorporated area that has a population of greater than 20,000 inhabitants; or
2. is not located within an urbanized area¹ contiguous and adjacent to a city or town that has a population of greater than 50,000 inhabitants.

B. Other Eligibility Criteria

In addition to being located entirely within a rural area, a service area must meet the following criteria to be eligible for a broadband loan:

1. At least 25 percent of the households are underserved, meaning they are offered broadband service by no more than one “incumbent service provider”. Incumbent service providers are broadband providers that RUS identifies as directly providing broadband service to at least 5 percent of the households within a service area.
2. No part of the service area has three or more “incumbent service providers.”
3. No part of the service area overlaps with the service area of current RUS borrowers and grantees, in which they are providing broadband service or has a loan or grant from RUS to provide broadband service and are within their approved construction schedules.
4. No part of the funded service area is included in a pending application before RUS seeking funding to provide broadband service. If two or more applications are submitted for the same service area, a lending decision must be reached on the application that was submitted to RUS first before consideration can be given to the other application(s).
5. No part of the funded service area is included in the service area of a borrower under Title VI that has completed the build-out period.

C. Exceptions

There are three service area exceptions for broadband facility upgrades:

1. If a current broadband borrower applies to upgrade existing facilities, the upgrade area is exempt from the requirement concerning the number of underserved households.
2. Incumbent service providers, including borrowers and grantees, that apply to upgrade existing broadband facilities in existing service areas are exempt from the requirement concerning the number of incumbent service providers unless they are eligible for funding under Titles II and III of the RE Act.
3. An applicant which is a borrower, grantee or incumbent service provider may submit one application to upgrade existing broadband facilities in existing service areas and expand into new service areas at the broadband lending

¹ An urbanized area is a densely populated territory as defined in the latest decennial census of the U.S. Census Bureau.

speed, provided the upgrade area and the expansion area are proposed as two separate service areas, even if the upgrade and expansion areas are contiguous.

An entity applying to the Broadband Loan Program must plan to use RUS funding to provide service to at least one eligible service area. An applicant may also offer service to ineligible areas in order to achieve overall project financial feasibility; however it must use non-RUS funding for those areas.

Non-contiguous areas MUST be treated as separate service areas for the purpose of determining service area eligibility.

Please note that some of the information required to make a final eligibility determination for a service area is collected after the application is submitted, as this information must be collected through a Public Notice process. Applicants must therefore thoroughly research the area(s) in which they propose to provide service and carefully account for each of the area eligibility criteria to the extent possible.

➤ ***6. Substantially Underserved Trust Areas***

If the Administrator determines that a community in “trust land” (as defined in section 3765 of title 38, United States Code) has a high need for the benefits of the Broadband Loan Program, he may designate the community as a “substantially underserved trust area” (as defined in section 306F of the RE Act).

In order to improve the availability of the Broadband Loan Program in communities in substantially underserved trust areas, the Administrator retains the discretion to:

- (1) Make available to qualified utilities or applicants financing with an interest rate as low as 2 percent, and with extended repayment terms;
- (2) Waive nonduplication restrictions, matching fund requirements, or credit support requirements; and
- (3) Give the highest funding priority to designated projects in substantially underserved trust areas.

The Administrator will only make loans and loan guarantees that RUS finds are financially feasible and that provide eligible program benefits to substantially underserved trust areas. Applicants must notify the National Office before preparing applications in which they are planning to seek waivers or adjustments.

➤ ***7. Preliminary Assessment of Service Area Eligibility***

Initial prospective applicants and their attorneys should review the terms and conditions set forth in the standard RUS broadband loan documents. Please note that additional

terms and conditions may apply once financial and technical feasibility has been determined (see Application Review and Notification Process). Copies of these documents can be obtained from the RUS web site at http://www.rurdev.usda.gov/utp_farmbill.html

RUS recommends that applicants identify and contact the appropriate GFR as early as possible when preparing a loan application (see contact information available online at http://www.rurdev.usda.gov/UTP_ContactStaff.html). The GFR can explain the regulations and requirements that govern the Broadband Program and offer guidance on preparing an application.

RUS will make information available to prospective applicants to allow a preliminary assessment of the eligibility of a service area. At a minimum, the prospective applicant will be able to obtain:

- (1) Whether the proposed service area is located in a rural area;
- (2) Whether the proposed service area overlaps with any part of a borrower's service area; and
- (3) Whether the proposed service area overlaps with any part of a proposed service area specified in a pending application for a loan.

A preliminary assessment of service area eligibility does not account for all eligibility factors, such as the presence and number of incumbent service providers. Furthermore, the eligibility factors within a proposed service area may change between the preliminary assessment and application submission. A preliminary assessment indicating that a service area may be eligible for funding does not guarantee that the area will be eligible at the time of application, nor does it mean that RUS will approve a loan for the applicant.

➤ ***8. Types of Broadband Loans***

1. **Direct Cost-of-Money Loan** – This loan will bear interest at a rate (the “Cost-of-Money Interest Rate”) equal to the cost of borrowing to the Department of Treasury for obligations of comparable maturity. The applicable interest rate will be set at the time of each advance. Department of Treasury interest rates are released daily and can be found in Release H.15 at <http://www.federalreserve.gov/releases/h15/update/>. The applicable interest rate is found below the heading “U.S. government securities” under the sub-heading “Treasury constant maturities.”
2. **Direct 4-Percent Loan** – Direct 4-Percent Loans shall bear interest at 4 percent on each advance made to the borrower. Such loans may be used by RUS, at its discretion, to assist applicants in meeting financial feasibility requirements for applications serving underserved areas. Additional eligibility requirements for Direct 4-Percent Loans may be published in the Federal Register. Direct 4-Percent Loans may be made simultaneously with a Direct Cost-of-Money Loan.

3. **Private Loan Guarantee** – This loan is a third party loan (not funded by RUS). This loan shall bear interest at a rate set by the lender consistent with the current applicable market rate for a loan of comparable maturity. RUS will guarantee up to 80 percent of the principal amount of the loan, excluding any and all charges and fees. Applicants interested in a loan guarantee should contact the Washington DC Broadband Office or the applicant’s GFR (for the most current contact information please see <http://www.rurdev.usda.gov/UTP>ContactStaff.html>).

In general, the broadband loan term will be equal to or less than the expected composite economic life of the assets to be financed by the loan, rounded to the nearest whole year. The expected composite economic life of the assets will be based upon acceptable depreciation rates. Applicants may request a repayment period that is shorter; such requests will be granted only if RUS determines that the loan would remain feasible. RUS may, at its discretion, extend the loan term up to 35 years for loans to provide service to underserved areas, i.e. areas that are not offered broadband service at all or are offered broadband service by only one incumbent service provider.

➤ ***9. Minimum and Maximum Loan Amounts***

The amount of funds available for each loan type in each Federal fiscal year, as well as the minimum and maximum loan amounts for each type of loan, will be published in the Federal Register.

An applicant that provides telecommunications or broadband service to at least 20 percent of the households in the United States is limited to a loan amount that is no more than 15 percent of the funds available to the Broadband Loan Program for the Federal fiscal year.

➤ ***10. Equity Requirement***

As a condition to financing, an applicant must have equity in an amount equal to 10 percent of the requested loan amount at the time of application which must remain available at loan closing. As defined in 7 CFR 1738, equity means total assets minus total liabilities, as determined by Generally Accepted Accounting Principles (GAAP). The applicant’s capacity to meet the minimum equity requirement will be apparent by reviewing the applicant’s Balance Sheet.

If an applicant cannot meet the equity requirement at the time the application is submitted, the applicant may submit an investor’s unconditional legal commitment in the application to cover the shortfall by providing additional equity. RUS will reject applications that do not provide evidence acceptable to RUS regarding the investor’s commitment.

State and local government applicants can satisfy the equity requirement with a general obligation bond (see instructions for Schedule J-2). Revenue bonds supported by the operations to be funded cannot be used to satisfy the equity requirement.

In addition, if RUS projects, based on the applicant's financial information, that the applicants entire operations will show a negative cash balance at the end of any year during the five-year forecast period, the applicant will be required to obtain additional cash infusions (for details on the Additional Cash requirement, see the instructions for Schedule M-5 below).

➤ **11. Priority Consideration**

The Food, Conservation and Energy Act of 2008 (Farm Bill) requires that in making and guaranteeing loans under this section, priority must be given to applicants that offer to provide broadband service to the greatest proportion of households that, prior to the provision of the broadband service, had no incumbent service provider.

To implement this requirement in a transparent and reasonable way, RUS will process applications for funding in the following order:

- (1) Applications in which no broadband service is available in any funded service area.
- (2) Applications in which at least 75 percent of households in the funded service area have no incumbent service provider. For applications with multiple funded service areas, the 75 percent calculation is based on all funded service areas combined.
- (3) All other applications.

Upon receipt, an application will be prioritized according to the above criteria in relation to all other applications received to date. The applications will be processed on a first-in, first-out basis within each priority category. As applications are processed on this basis, RUS may expedite applications proposing to provide service where none is available.

➤ **12. Public Notice**

All applicants must provide information necessary for RUS to post a public notice on its website announcing an applicant's intention to offer service at the broadband lending speed. The public notice will remain on RUS' webpage for a period of 30 calendar days and will ask existing service providers to submit to RUS, the following information:

- The number of residential and business customers within the applicant's service area that are currently offered broadband service by the existing service provider;

- The number of residential and business customers within the applicant’s service area currently purchasing the existing service provider’s broadband service, the rates of data transmission being offered, and the cost of each level of broadband service charged by the existing service provider;
- The number of residential and business customers within the applicant’s service area receiving the existing service provider’s non-broadband services and the associated rates for these other services;
- A map showing where the existing service provider’s services coincide with the applicant’s service areas; and
- Whether the existing service provider is an existing RUS borrower or grantee.

The information submitted by an existing service provider will be treated as proprietary and confidential to the extent permitted under applicable law. RUS will use the information to determine whether the existing service provider will be classified as an incumbent service provider, which in turn will impact the determination of eligibility for the applicant’s service area(s). If an existing service provider does not submit a response within the specified timeframe, it will not be considered an incumbent service provider. However, all existing service providers will be considered in RUS’s feasibility study and lending decision.

➤ ***13. Application Submission***

Applications can be submitted throughout the year and will be reviewed and processed on a first-come, first-served basis according to the time the application is received at the Washington DC Broadband Office listed below. Submit an original and one copy of the completed application along with an electronic version (including electronic versions of service area maps, network diagrams and any other maps or diagrams) to the applicant’s Rural Development General Field Representative (GFR) for the Telecommunications Program or directly to the Washington DC Broadband Office at the following address:

U.S. DEPARTMENT OF AGRICULTURE
 RURAL UTILITIES SERVICE
 BROADBAND DIVISION
 ATTN: KENNETH KUCHNO
 STOP 1599, ROOM 2868-S
 1400 INDEPENDENCE AVENUE, SW
 WASHINGTON, DC 20250-1599

Applications delivered by hand to the Washington DC Broadband Office will be accepted daily between 8:00 a.m. and 4:30 p.m. (Eastern Time), except Saturdays, Sundays and Federal holidays. Individuals delivering applications must provide proper identification (with picture ID) to enter the building. ***All applications are stamped as received only upon receipt in the Washington Broadband Office.***

A current listing of GFR contact information can be found at:

➤ **14. Application Review and Notification Process**

Once an application has been received in the Washington Broadband Office and categorized according to the prioritization criteria, the application will be reviewed for eligibility, completeness and quality as follows:

1. RUS will determine through a Public Notice process whether the service area(s) in the application are eligible for funding. See details in the instructions for Public Notice under the “General Information” section and instructions for Schedules F-1 and F-2 of this guide. The information submitted by existing service provider(s) will be considered proprietary and confidential.
 - If RUS determines that all service area(s) are eligible, program staff will proceed to review the application for completeness.
 - If RUS determines that one or more service area(s) are not eligible for funding, program staff will notify the applicant of all ineligible areas. Broadband service in ineligible areas cannot be financed with RUS loan funds; however, the ineligible areas may remain as part of the application to support financial feasibility.
2. The completeness review will include an assessment of whether all required documents and information have been submitted, and whether the information provided is of adequate quality to allow for further analysis.
 - If the application is complete and of adequate quality, program staff will notify the applicant in writing that the application is complete. RUS may still request additional information to complete the financial and technical feasibility evaluations.
 - If the application is of adequate quality but incomplete, program staff will notify the applicant in writing that the application is incomplete. The notification of incompleteness will include a list of items that the applicant must address by a specified date.
 - If the applicant fails to respond by the specified date, the application will be rejected.
 - If the applicant responds by the specified date but does not satisfactorily address the issues identified, program staff will assess the applicant's progress toward submission of a complete application. If the applicant has made acceptable progress, a second notification of incompleteness will be provided. If the applicant's progress is not acceptable, the application will be rejected.

- o If the application is not of adequate quality, program staff will notify the applicant in writing that the application has been rejected. The rejection letter will include an explanation of the reasons for the rejection.

After an applicant is notified that the application is complete, RUS will evaluate the application's financial and technical feasibility, as well as its compliance with statutory and regulatory requirements, as follows:

1. RUS will only make a broadband loan if the applicant's financial operations, taking into account the impact of the facilities financed with the proceeds of the loan and the associated debt, are financially and technically feasible, as determined by RUS.
2. Financial feasibility will be determined by evaluating the applicant's equity, market survey (if required), competitive analysis, financial information, and other relevant information in the application.
3. Technical feasibility will be determined by evaluating the applicant's network design in conjunction with other relevant information in the application.
4. If the application meets all statutory and regulatory requirements and the feasibility study demonstrates that the TIER requirement can be satisfied (see the section on Financial Position), the application will be submitted to RUS' credit committees for consideration. Submission of the application to the credit committees does not guarantee that a loan will be approved.

The applicant will be notified of RUS's decision in writing as follows:

1. If the loan is approved, a loan offer will be extended. The applicant will typically have 10 working days to accept the offer.
2. If the loan is not approved, a rejection letter will be sent to the applicant and the application will be returned with an explanation of the reasons for the rejection.

➤ **15. Contact Information**

For additional information concerning this loan program, please contact the General Field Representative (GFR) for the Telecommunications Program in the respective state and/or any member of the Broadband Team. The contact information for the Broadband Team and the GFRs can be found at the following address:

http://www.rurdev.usda.gov/UTP_ContactStaff.html

Information about the RUS Telecommunications Program and this application guide can also be found at:

http://www.rurdev.usda.gov/utp_farmbill.html

Instructions for Completing the RUS Form 532

The RUS Form 532, Application for Broadband Loan or Loan Guarantee, is a three-page form that must be completed and certified by an authorized official of the entity applying for the loan. The applicant's name should be inserted in the footers for identification purposes.

1. NAME & ADDRESS OF APPLICANT – Enter the legal name and address of the entity requesting the loan.
2. REGISTERED AGENT (Address, Telephone and Fax) – Enter the name, address, phone and fax numbers of the registered agent of the applicant.
3. PHONE NUMBER – Enter the phone number of the applicant.
4. FAX NUMBER – Enter the fax number of the applicant.
5. E-MAIL ADDRESS – Enter the e-mail address of the person responsible for answering questions about this application.
6. CONTACT PERSON – Enter the name of the person responsible for answering questions about this application.
7. TYPE OF ORGANIZATION - Check the appropriate box that describes the legal structure of the applicant.
8. TYPE OF LOAN – Check the type of loan requested. (See Types of Broadband Loans under the “General Information” section for additional information on each type of loan). For applicants that select Direct Loan, please note that RUS may choose to offer a cost-of-money loan or a 4 percent loan, or a combination thereof, at its discretion.
9. REFINANCING/ACQUISITION – Check appropriate box(es) if loan funds are requested for refinancing and/or acquisition; otherwise check Not Applicable.
10. PURPOSE OF LOAN - Briefly explain the purposes for which loan funds are requested and the respective amount. (See Loan Purposes under the “General Information” section of this guide for additional information on eligible/ineligible purposes of the loan.)
11. LOAN MATURITY REQUESTED – Check the appropriate box to select the loan maturity requested. (See Types of Broadband Loans under the “General Information” section of this guide for a discussion of the Program’s requirements for loan maturity.)
12. AMOUNT OF LOAN APPLIED FOR – The total amount of loan funds requested from RUS in this loan application. (Please note the minimum and maximum amount restrictions discussed under the “General Information” section of this guide.)
13. IDENTIFICATION INFORMATION – Enter the applicant’s Tax Identification Number (TIN) or the Federal Employer Identification Number (FEIN) in the spaces provided. Enter the applicant’s Dun & Bradstreet DUNS number in the space provided.

14. ORGANIZATIONAL NUMBER – Enter the organizational number of the applicant issued by the state in which the corporation was formed or the LLC was organized. Refer to state registration approval for the type of entity:
http://www.uccdirect.com/resource_chart.htm
15. TYPE OF BORROWER – Indicate whether the applicant has an outstanding broadband or telecommunications loan made or guaranteed by RUS.
16. UPGRADE OR EXPANSION OF NETWORK – Indicate whether this application is seeking funding to upgrade or expand an existing network, and/or build a new network.
17. CONGRESSIONAL DISTRICTS – Include the information required on the congressional districts as Schedule A.
18. EXECUTIVE SUMMARY – Include the information required on the Executive Summary as Schedule B.
19. LEGAL OPINION AND PROPERTY SCHEDULES – Include the legal opinion and the real property schedule. The legal opinion and the real property schedule should be included in the application as Schedules C-1 and C-2, respectively.
20. CORPORATE STRUCTURE – Include information on the legal structure of the applicant, its by-laws or operating agreements, its Board of Directors or Managing Members, the management team’s experience and compensation, its organizational chart, and its parent/subsidiary relationships, as Schedules D-1 through D-6.
21. BOARD RESOLUTION – Include the Board of Director’s resolution authorizing the funding request as Schedule E.
22. SERVICE AREA MAPS AND DETAILS – Check the box to confirm that you have electronically submitted service area maps through RUS’ Mapping Tool. Provide the required demographic data for each service area as Schedule F-2.
23. SERVICE AREA – EXISTING or NEW; FUNDED or NON-FUNDED – Include the tables on the existing and new service areas and funded and non-funded service areas as Schedule G.
24. COMPLIANCE CERTIFICATES – Include certified copies of these forms in the application as Schedules H-1 to H-6.
25. OUTSTANDING FEDERAL DEBT – Check appropriate box on Form 532. Use Schedule I to list all outstanding Federal debt and, for each loan, indicate whether the loan documents are attached to the application.
26. EQUITY – If the equity requirement is being met by the Applicant’s Equity, this should be evident on Schedule M-4a (under Financial Position). If not, include (a) Schedule J-1, and the Investor Proposal and supporting documentation indicating that the investor has the capacity to perform; and/or (b) Schedule J-2, documentation of a State or local government’s authority and capacity to issue a State/Local Government Bond.
27. RESEARCH DATA & MARKET ANALYSIS– Include the information required as part of the Research Data as Schedule K-1 and for the Market Analysis as Schedule K-2.

28. **COMPETITIVE ANALYSIS** – Include as Schedule L-1 the analysis of existing providers who are competitors. Include the strategic plan as Schedule L-2.
29. **FINANCIAL POSITION** – Include the information required on the Financial Position of the applicant. These schedules cover six major areas: complete financial statements, preferably audited, for the preceding three years (Schedule M-1); detailed information on all existing indebtedness (Schedule M-2); the projected subscriber base for each type of service to be offered (Schedule M-3); the projected financial statements for each of the five years of the forecast period (Schedule M-4A); Pro-Forma financial assumptions (Schedule M-4B); estimate of whether additional cash is needed and documentation to support the capacity to make the cash investment (Schedule M-5), and depreciation schedule for the assets proposed for purchase with the loan funds (Schedule M-6).
30. **NETWORK DESIGN** – Include the information required for the Network Design as Schedules N-1, N-2 and N-3, respectively.
31. **NETWORK DIAGRAMS** – Include the Existing and Proposed Network Diagrams as Schedules O-1 and O-2, respectively.
32. **PROJECT COSTS** – Include the completed Project Capital Investment Workbook as Schedule P and note the total cost of the project in the space provided on the form.
33. **ENVIRONMENTAL REPORT** – Include the Environmental Report for the proposed project as Schedule Q.
34. **LICENSES AND AGREEMENTS** – Provide a status report on the licenses, agreements, approvals, and authorizations required for constructing your broadband network by completing the Schedule R template.

Overview to Preparing Schedules A through S

When preparing an application, RUS encourages applicants to think of the entire application as a business plan that is being presented for consideration. It should present the project's goals and activities with a convincing argument to demonstrate that the applicant has sufficient management experience and capacity, financial wherewithal, a sound technical approach with the experience and skills to implement the plan, and the marketing plan and knowledge to ensure the project's success.

In addition to demonstrating the financial and technical feasibility of the applicant's plan, the applicant also must demonstrate that the project will help RUS achieve the goals of the Broadband Program and that the project can meet the program's regulatory requirements.

RUS conducts a rigorous financial and technical evaluation of each complete application in an effort to make loan decisions that are in the best interest of the Federal Government and the rural communities that will benefit from broadband access. Applicants are urged to develop and submit applications that meet or exceed these standards.

RUS generally obtains a first lien on all assets owned by the applicant and purchased with the loan funds as well as all revenues. RUS will consider sharing a first lien position with another lender on a *pari passu*, prorated basis. RUS will not consider being subordinate to another lender.

Instructions for Preparing Schedules A & B

[CONGRESSIONAL DISTRICTS \(Schedule A\)](#)

To complete Schedule A, applicants must provide the congressional district where the applicant's headquarters are located and the congressional district(s) that cover the service area(s) included in the proposed project.

[EXECUTIVE SUMMARY \(Schedule B\)](#)

To complete Schedule B, applicants must provide an executive summary about the proposed project. This should include a brief description of the proposed project, state the reason why the system is needed and the qualifications of the applicant that demonstrate the ability to construct and operate the broadband system. It should also state the number and names of the rural areas to be served, the proposed type of broadband system that will be deployed and the overall cost of the broadband system.

Instructions for Preparing Schedule C

LEGAL OPINION AND PROPERTY SCHEDULE (Schedules C-1 and C-2)

- Legal Opinion – A legal opinion shall be prepared in accordance with the sample format as shown on the Schedule C-1 template. The legal opinion should address the applicant’s ability to execute legal documents, and describe all pending litigation matters. The applicant’s legal counsel must submit an executed opinion on counsel’s letterhead.
- Real Property Schedule – A real property schedule shall be prepared in accordance with the sample format as shown on the Schedule C-2 template. The real property schedule should include the legal descriptions of all the real property owned by the applicant. It should be categorized into real property, leased-property, easements, and rights-of-way.

Instructions for Preparing Schedules D & E

CORPORATE STRUCTURE (Schedules D-1 through D-6)

- Articles of Incorporation or Organization Agreement – Include a registered copy of the Articles of Incorporation or Organization Agreement of the applicant as Schedule D-1.
- Bylaws or Operating Agreements -- Attach as Schedule D-2 a copy of the Bylaws or Operating Agreements of the applicant. If the applicant is an LLC, or any of the applicant’s members are LLCs, the applicant must submit either of the following:
 - 1) LLC agreements for all members of the applicant’s LLC; or
 - 2) An opinion of counsel which certifies that the applicant’s agreement does not conflict with any of the LLC agreements of the applicant’s members.
- Board of Directors or Managing Members – Schedule D-3 shall include a list of the applicant’s board members and a brief biography to highlight their experience within the applicant’s industry and community.
- Management Experience and Compensation – Schedule D-4 shall include information on the key personnel who manage or will manage the company and this project. At a minimum, the following information shall be provided for each member of the management team:
 - o Duties and responsibilities related to this project and to any other project

- Detailed description of qualifications, focusing on how each person's previous ten years of work experience directly relates to his or her ability to perform the duties and responsibilities described above
- Resume for each team member detailing positions held for the 10 years previous to the date on which the application is submitted
- Salaries
- Stock Ownership
- Bonus Plans
- Individual Equity Investments

In addition, the following two items should also be addressed in this Schedule:

- Describe the extent to which this management team has worked together previously, and name particular initiatives or projects, if any, that the team has previously undertaken together.
 - How do the management team's skills complement each other?
- Organizational Chart – Attach as Schedule D-5 an organizational chart showing the key personnel who manage or will manage the company and/or this project, and the number of employees in each division or department managed by those personnel. A sample organizational chart is provided on the next page. This is only a sample and must be tailored to reflect the applicant's organization. An applicant's organizational chart(s) should reflect both company structure and key staff, whether this is achieved using one or more charts.

Sample Organizational Chart (Schedule D-5)

Company Name

Sample Company Organizational Chart

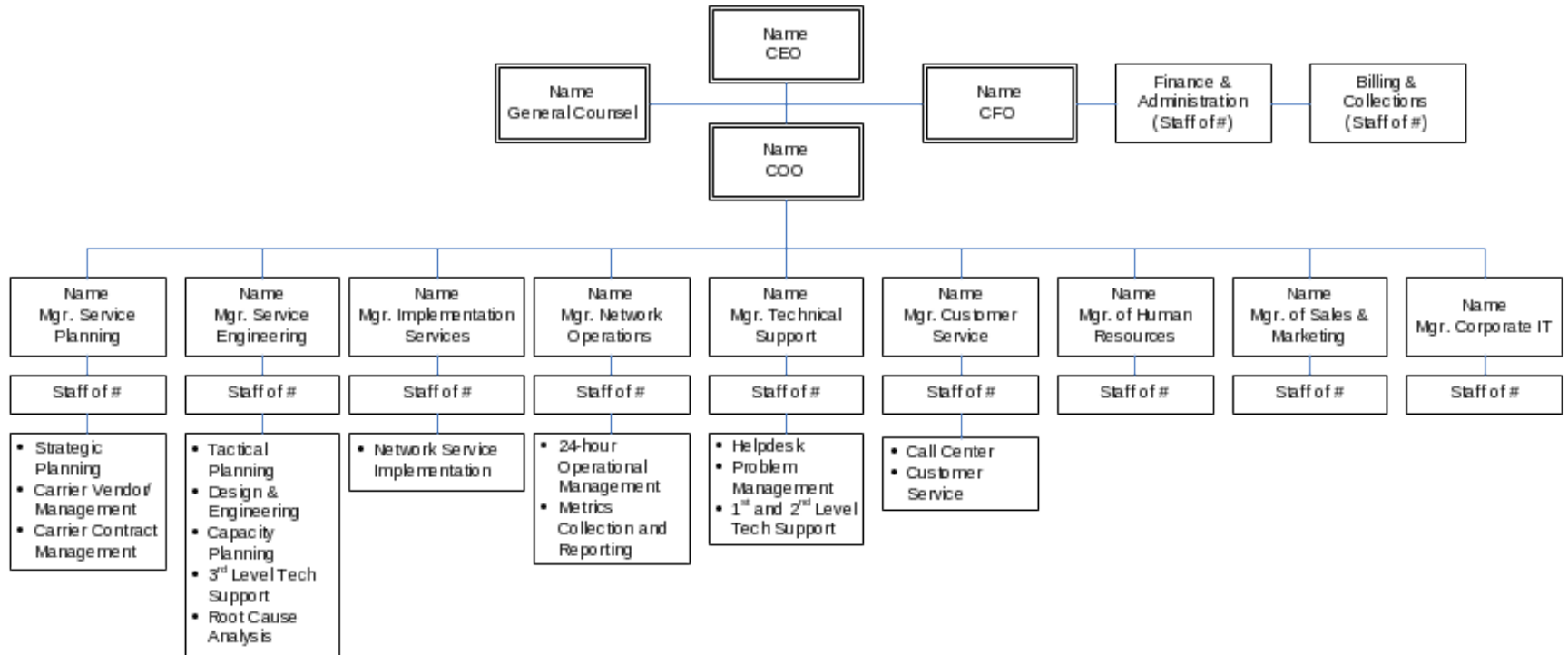

End of Sample Organizational Chart (Schedule D-5)

- Parent and Subsidiaries** – Schedule D-6 shall include an organizational chart illustrating all the other entities (parent/subsidiaries) that are affiliated with the applicant and clearly indicating the relationships between these entities and the applicant. An accompanying narrative should briefly indicate any services that the affiliate will be providing to the applicant or that the applicant will be providing to the affiliate. See the sample organizational chart below. This is only a sample and must be tailored to reflect the actual structure of the applicant’s organization.

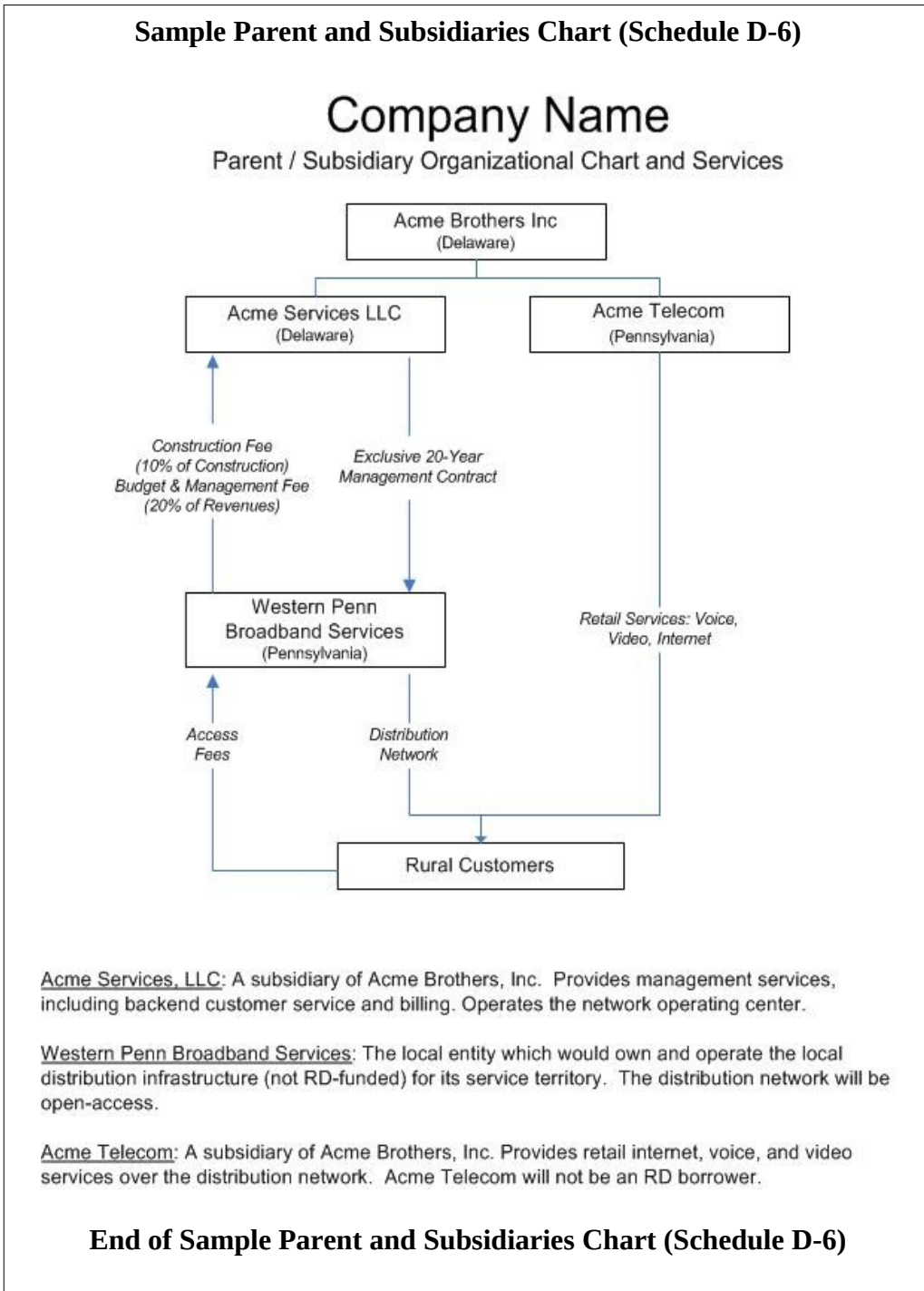

[BOARD RESOLUTION \(Schedule E\)](#)

A Board of Directors' resolution or other document authorizing the funding request should be included as Schedule E.

Instructions for Preparing Schedule F

[SERVICE AREA MAPS AND DEMOGRAPHIC DATA \(Schedules F-1 and F-2\)](#)

To complete schedule F-1 and F-2, applicants must go to RUS' web-based Mapping Tool to electronically designate and submit maps of their service area(s) and provide additional demographic data about those service area(s). RUS will use this data to post a public notice of the application. This notice will be posted on RUS' website for 30 calendar days. During that 30-day period, existing service providers will be able to submit information to RUS regarding their existing service offerings. RUS' Mapping Tool can be accessed at: <http://broadbandsearch.sc.egov.usda.gov/>

- 1) Service Area Map(s) - Schedule F-1 shall include a map of each service area and demographic data about each service area. Each map must identify the rural area boundaries and the underserved areas within the service area. (An underserved area means an area that is not offered broadband service, or that is offered broadband service by only one incumbent service provider.)

Applicants must submit their service area maps and demographic data through RUS' web-based Mapping Tool. Applicants must provide the Mapping Tool Reference Number assigned for their application with Schedule F-2. Please note that no matter how many service area(s) are within a single application, you should draw each map under the same application. Each application should have only one associated Map Reference Number. Applicants should ensure that their Reference Number follows this format:

XXXX-XXXX-XXXX-XXXX

To ensure accurate mapping for proposed projects:

- A service area is defined as the geographic area within which a service provider offers telecommunications services. An application may include one or many service areas. Each service area should be drawn as a separate map which will then be rolled up into one single project with a single Map Reference Number.
- Each non-contiguous geographic area should be treated as separate service area. However, a borrower, grantee or incumbent service provider may submit one application to upgrade existing broadband facilities in existing service areas and expand into new service areas at

the broadband lending speed, provided the upgrade area and the expansion area are proposed as two separate service areas, even if the upgrade and expansion areas are contiguous; and

- Each and every proposed funded service area in an application must be entirely rural. Meaning it cannot overlap with any portion of a non-rural area.

2) Service Area Demographic Data (Schedule F-2) – Applicants must complete the Schedule F-2 template by providing the Map Reference Number assigned to their application and providing the following information for each service area:

- The name of the service area (please ensure this is the same name you assigned to the service area in the RUS Mapping Tool).
- The total number of households that lie within the service area.
- The estimated number of underserved households in the service area.
- The estimated number of households without terrestrial-based broadband service in the service area.
- A description of all the types of services to be provided in the service area.

Sample Service Area Demographic Data (Schedule F-2)					
	Service Area	Total Number of Households	Number of Underserved Households (0 or 1 Incumbent)	Number of Households without Terrestrial-Based Broadband Service	Type(s) of Services to be Provided
1	Moon County	75,245	16,000	9,500	Data, Video and Voice
2	Sun County	25,223	9,500	2,000	Data and Voice
End of Sample Service Area Demographic Data (Schedule F-2)					

Instructions for Preparing Schedule G

SERVICE AREAS - NEW or EXISTING; FUNDED or NON-FUNDED (Schedule G)

Schedule G must be completed for all existing service areas (if any) served by the applicant, as well as all new service area(s). For each service area, the applicant must indicate whether RUS loan funds will be used.

Applicants should list each of their service areas in accordance with the following categories:

- New or Existing:
 - New -- Designate a service area as “New” if the applicant does not provide broadband service to this area.
 - Existing -- Designate a service area as “Existing” if the applicant currently provides broadband service to this area.
- Funded or Non-Funded:
 - Funded -- Designate a service area as “Funded” if the applicant proposes to use RUS broadband loan funds received under this application in this service area to provide broadband service at the broadband lending speed.
 - Non-Funded -- Designate a service area as “Non-Funded” if RUS funds will not be used in the service area.

Indicate the Rural Area(s), County (or Counties) and the State(s) covered by each service area; the population of each Rural Area, the number of Households (HH) in each rural area; and the number of Businesses (Bus) in each rural area. These statistics should start with the most recent available data provided by the U. S. Census Bureau (see <http://www.census.gov/>) and can be supplemented with more current information. Applicants should provide such data for each area they serve or plan to serve, regardless of whether the area qualifies for RUS funding.

Instructions for Preparing Schedules H, I & J

COMPLIANCE CERTIFICATES (Schedules H-1 through H-6)

Schedules H-1 through H-6 are forms that need to be certified by the applicant to ensure compliance with Federal statutes and regulations. All forms should be certified with original signatures. Using the forms “as-is” will expedite application processing.

- A. Equal Opportunity and Nondiscrimination Certification (Schedule H-1)
- B. Certification Regarding Architectural Barriers (Schedule H-2)

- C. Uniform Relocation Assistance and Real Property Acquisition Policies Act of 1970 Certification (Schedule H-3)
- D. Certification Regarding Debarment, Suspension, and other Responsibility Matters – Primary Covered Transactions (Schedule H-4)
- E. Certification Regarding Lobbying for Contracts, Grants, Loans, and Cooperative Agreements (Schedule H-5)
- F. Certification Regarding Flood Hazard Area Precautions (Schedule H-6)

OUTSTANDING FEDERAL DEBT (Schedule I)

Check the appropriate box (yes or no) on Form 532 to indicate whether the applicant is delinquent on any Federal debt, or if the applicant has any outstanding Federal debt. Attach as Schedule I, using the template provided, a list of all outstanding Federal debt and, for each loan, indicate whether the loan documents are attached to the application.

EQUITY (Schedules J-1 and J-2)

To be eligible for a loan, and as a condition to RUS financing, an applicant must have equity in an amount equal to 10 percent of the requested loan amount at the time of application. That equity must remain available at loan closing. Equity means total assets minus total liabilities, as determined by GAAP. The applicant’s capacity to meet the minimum equity requirement will be determined by reviewing the applicant’s balance sheet.

- A. Equity. If an applicant’s balance sheet can demonstrate fulfillment of the equity requirement at the time the application is submitted, this should be evident on Schedule M-1 submitted under Financial Position. Schedule M-1 does not need to be attached again here.
- B. Investor Proposal. If an applicant’s balance sheet cannot demonstrate fulfillment of the equity requirement at the time the application is submitted, the applicant must submit, as Schedule J-1 in the application, an investor’s unconditional legal commitment to cover the shortfall by providing additional equity. The additional equity must be transferred to the applicant prior to loan closing. Schedule J-1 must include, at a minimum:
 - 1. A letter from the investor indicating the investor’s unconditional legal commitment, the timing for providing the investment, the amount of investment, and all terms and conditions associated with the investment (RUS may reject investments that do not prohibit redemption of the investment until such time as stated requirements and financial thresholds are achieved by the applicant); and
 - 2. Bank or financial statements from the investor that demonstrate the investor’s ability to meet its commitment to the applicant.

If this option is selected and the support information is not included, the application will be rejected.

- C. State or Local Government Bond. Schedule J-2 is to be used by State and Local Governments who wish to satisfy the equity requirement with a general obligation bond that is not senior to the broadband loan (in practice, this generally means that the bond is *pari passu* with the broadband loan).
1. The applicant must submit an opinion from its legal counsel, acceptable to RUS, that the applicant has the authority and capacity to issue a general obligation bond in an amount sufficient to meet the minimum equity requirement.
 2. With receipt of an acceptable opinion, RUS can proceed with its review of the application.
 3. If RUS extends a loan offer to the applicant, the general obligation bond must be issued and the applicant must have the cash deposited in its bank account before the loan closing can occur.
 4. Revenue bonds supported by the operations to be funded cannot be used to satisfy the equity requirement.

Instructions for Preparing Schedule K

RESEARCH DATA AND MARKET ANALYSIS (Schedules K-1 and K-2)

Market research is critical in determining the interest and demands of the targeted rural areas for the services offered. This research provides the applicant with knowledge of market potential and knowledge of the needs/demands of the potential customer base. But most importantly, market research supports feasibility studies and strategic planning goals.

Therefore, a market survey, satisfactory to RUS, shall be conducted by the applicant in **each** service area where the applicant proposes to provide service at the broadband lending speed. This means that non-contiguous service areas must also be treated separately for the purpose of the market survey requirement.

The market survey will collect data from potential subscribers (both residential and business) on the service offerings and the respective rates to determine the level of interest in the services and rate plans to be offered by the applicant.

The market survey must demonstrate the need for services at the broadband lending speed as well as any other service being offered, support the projected penetration rates

and price points for the services to be offered, and support the feasibility analysis. The market survey must address all services (i.e. voice, data, video, etc.) that will be funded with the broadband loan or loan guarantee except as follows:

- The applicant is **not** required to complete a market survey for any service offering for which the applicant is projecting less than a 20 percent penetration rate in each service area by the end of the five-year forecast period. For example, if the applicant is projecting a penetration rate of 30 percent for data services and 15 percent for video services in a particular service area, a market survey must be completed only for the data services in that service area. It is recommended that if a market survey is required for any service offering that the survey includes all service offerings.
- The Administrator may modify the requirements of the market survey for loans in service areas that are “underserved” when it is in the best interest of the Agency.

RUS may reject any application in which the financial projections are not supported by the market survey. If the demographics of the proposed service area have significantly changed since the survey was completed, an updated market survey may be required.

Market surveys will only be accepted if they were conducted within six months preceding the date of submission of the application to RUS.

Market surveys can be conducted through the following media:

1. Direct mail;
2. Telephone;
3. Door-to-door interviews; and
4. Town Meetings
 - i) Coordination with local government officials
 - ii) Coordination with local Chamber of Commerce
 - iii) Announcements by local TV, radio, and newspapers

The applicant must capture a representative sample of both the residential and business sectors of each service area included in the application regardless of whether the areas are being funded by RUS loan funds or other sources.

The survey questionnaire used for conducting the market survey should, at a minimum, capture the following information:

1. Ownership of computers and Internet usage (including time online);
2. Existing service provider, types of services offered, rate plans (both price and transmission rates), satisfaction with current provider;

3. Proposed services offered by applicant, the respective rate plans (including any one-time fees), and the timeline for providing those services;
4. Incentive/introductory packages offered by the applicant;
5. Interest in switching service providers and reasons for switching (price, service level, customer service/local presence); and
6. Economic and social demographics including age, income level, and family/household members.
7. Types of broadband services desired by the customer, including data (internet access), voice services, streaming video, interactive video, peer-to-peer, on-line gaming, and other (please specify).

A. Research Data (Schedule K-1)

Schedule K-1 shall contain the methodology for conducting the market survey, the tabulated results for each service area, and a copy of the questionnaire used in the market survey. The presentation of survey results shall include:

1. Total number of surveys sent;
2. Total number of respondents;
3. Number and percent of responses to each question; and
4. Cross-tabulations for income levels, computer ownership, Internet usage.

B. Market Analysis (Schedule K-2)

Schedule K-2 shall contain an analysis of the research data as follows:

1. The applicant will draw conclusions regarding projected subscriber levels across the different service levels/rates for each service area for each year of the financial forecast. The results will clearly differentiate business subscribers from residential subscribers. The results will be based on the tabulated data from the market survey, as well as other market data gathered with respect to existing and potential competition, and demographics of each service area.
2. The results shall be for each service area taking into account each service area's individual circumstances and shall be based on the number of households/businesses in each service area and not the population of the service area.
3. The applicant must clearly explain the methodology behind the final subscriber projections. Subscriber projections based on population numbers and national/state statistics are not acceptable on their own. Projections must be supported from the research data provided in this section.

Instructions for Preparing Schedule L

COMPETITIVE ANALYSIS (Schedules L-1 and L-2)

The applicant must submit a competitive market analysis for each service area that will be included in the feasibility analysis, regardless of projected penetration rates. This means that non-contiguous service areas must also be treated separately for the purpose of the competitive analysis requirement.

- A. Schedule L-1 shall contain the following information:
1. A list of all existing service providers and all resellers competing in the applicant's service areas (and the broader market area, if applicable), including cable TV operators, regardless of the provider's market share, for each type of service the applicant proposes to provide.
 2. Information on each competitor's service offerings and pricing, the area that is being covered, and to the extent possible, a description of the quality of services being provided.
- B. Strategic Plan - Schedule L-2 shall be a narrative that describes the applicant's strategic approach for how it intends to successfully compete against existing service providers. This analysis should compare the applicant's offering with their competition's and describe how the applicant will successfully win new customers, including those of its competitors. The narrative shall describe any incentives, marketing and pricing strategies, as well as strategies the applicant will use to counteract any advantages or strategies used by the competition.

Unless addressed in the Market Analysis in Schedule K, the Strategic Plan should also include:

1. A description of the applicant's primary market:
 - a. Geographic area to be served should agree with the service areas detailed in Schedule F-1.
 - b. Factors affecting market growth should be described including how they will impact applicant plans, and how the applicant will mitigate risks and penetrate the current markets.
2. The current status, prospects, and trends influencing the industry in the applicant's target areas.
3. A description of targeted customers including the key factors that influence their service selection decisions. This should be substantiated from a market analysis, if required.

4. A description of the applicant’s pricing strategy and pricing goals for the short- and long-term, including ramp-up and market share.
5. A description of the applicant’s approach to advertisement and promotion of services, i.e. how the applicant will reach the most customers and deter competitors. Include a description of the advertisement and promotions strategy, marketing plan, the cost to execute the marketing plan, and the messages the applicant will provide to the target markets. It should compare the marketing approach to the current marketing programs competitors are pursuing or are likely to pursue.

If broadband service is proposed to be offered in an area where there are no households (“green field” area), the application must include information that justifies the subscriber penetration rates since no market information is available. This information might include:

- Subscriber penetration rates from comparable rural areas
- Census data on income levels compared to other rural areas
- Census data on age levels compared to other rural areas
- Census data on computer ownership compared to other rural areas
- Permits, plans, plats, or other documentation submitted to or approved by local authorities that supports the applicant’s projections of population growth in the area to be served
- Subscriber penetration by satellite service providers
- Letters of support from residents and community leaders in the rural area
- Minutes of “town hall” meetings held in the rural area
- And any other information that supports your projections.

Informal or casual knowledge about existing service providers is generally inadequate to develop an effective strategy for an applicant to successfully compete in a market. The competitive analysis should demonstrate that the applicant has detailed knowledge of its competitors, an understanding of its competitor’s strategies, investments and capabilities, and presents its own strategy for successfully competing against these competitors.

Instructions for Preparing Schedule M

FINANCIAL POSITION (Schedules M-1 through M-6)

RUS will approve a loan only if, in RUS’s sole judgment, the loan will be repaid according to its terms and within the time agreed upon. It is the applicant’s responsibility to provide sufficient financial information and supporting justification to determine that the loan request meets all of RUS’s requirements, will be feasible, and is adequately secured. Long-term forecast analysis should be based on knowledge of the external and internal factors that affect a company’s operations. Historical financial statements

(audited, if available) and the projections (subscriber estimates and pro forma financial statements) should be prepared by a financial consultant, accountant or individual qualified to prepare these types of financial statements and supporting schedules. The applicant must submit evidence of the preparer's qualifications.

In order to determine financial feasibility of the project, the applicant must achieve a projected Times Interest Earned Ratio (TIER) of at least 1.25 by the end of the five-year forecast period, based on the applicant's existing operations and new operations combined.

$$TIER = \frac{\text{Net Income (after taxes) + Total Interest Expense}}{\text{Total Interest Expense}}$$

TIER is defined as the ratio of an applicant's net income (after taxes) plus (adding back) interest expense, all divided by interest expense (existing and that required in the proposed loan), and with all financial terms as defined by GAAP. For the purposes of this calculation, all amounts will be annual figures and interest expense will include only interest on debt with a maturity greater than one year.

Historical Financial Statements (Schedule M-1)

As applicable, attach the below listed items as Schedule M-1:

1. What to Include: Financial statements of the applicant for the last three years, or for as long as the applicant has been in business, if less than three years, must be provided. Historical financial statements for the last three years must also be supplied for each co-applicant. The financial statements must include the balance sheet, income statement and statement of cash flows, as well as any accountant's letter and the notes to the financial statements. Audited financial statements are preferred.
2. Alternatives to Audited Financial Statements: If audited statements are not available for the last three years, the applicant must submit un-audited financial statements and tax returns for those years. Applications from start-up entities must at a minimum provide an opening balance sheet dated within 30 days of the application submission date. A startup entity may also choose to submit a tax return if audited statements are not available, in addition to the opening balance sheet.
3. Parent Companies, Subsidiaries, Affiliates and Others: If the applicant has a parent company and/or one or more subsidiaries, the historical financial statements for the preceding fiscal year of those entities are also required. If another affiliated or unaffiliated company is providing operations and management services to the applicant, that company's historical financial statements should also be included. Audited financial statements are preferred;

however, see the preceding item for acceptable alternatives if audited financial statements are not available.

Schedule of Debt and Equity Funding (Schedule M-2)

Applicants must submit the RUS-provided Schedule of Debt and Equity Funding (Schedule M-2), along with supporting documentation, to provide detail for all existing long-term liabilities, loans, and capital leases. It also documents new non-RUS funding sources that will be needed to fund the Broadband Loan project, working capital, and any other capital projects planned during the forecast period.

As with other schedules made available by RUS, applicants may modify this schedule to include additional information as needed, given that any modifications are adequately explained. Use the document as a checklist to record the submission of documentation supporting each source of external funding and to provide relevant details for review.

The worksheet is broken into two sections:

- **Existing Loan Term Obligations** - For each long-term debt or obligation, include a description of loan, principal amount, annual interest rate, term, number of payments, annual payment amount, and start date. Also indicate whether supporting documentation for the loan or lease has been submitted with the application. Supporting documentation includes copies of loan agreements, commitment letters, or leases.
- **Proposed Non-RUS Funding Sources** - Enter other funding anticipated to support this application's pro forma financial statements. Non-Broadband Loan funding for the capital budget and working capital should include documentation of equity, debt, or other contributions (such as in-kind contributions), including a list of the committed sources of capital funding. A brief description of each should be included. **Do not list the requested Broadband Loan here.** For other contributions, applicants must provide documentation supporting the cash valuation of each contribution.

Applicants must submit documentation substantiating any funds listed in the Schedule of Debt and Equity Funding, for all existing debt and obligations, and all forms of external non-Broadband Loan funding used to fund the proposed project. The documentation must substantiate the outstanding debt, obligations, and external non-Broadband Loan funding for the applicant's organization, not other entities such as parents or affiliates. Please note that the source documentation must also reflect any co-applicants.

To provide evidence of existing debt, include copies of existing notes, loan and security agreements, guarantees, and capital leases. To provide evidence of external funding, include copies of all formal commitments from your parent company, investors, and/or third parties, such as commitments of funding from banks, evidence of loan agreements,

and signed agreements from the board of directors. If a parent company is providing funding or any other support, proof of such support is required.

Subscriber Projections and Service Tiers (Schedule M-3A, B and C)

The RUS-provided Excel spreadsheet for Schedule M-3 for this attachment consists of a single worksheet. **Applicants must submit subscriber projections for each and every service area proposed for the Broadband Loan project.**

Subscriber projections must be broken down by service area, service offering (IP Data, Video, or Voice), service type, tier, pricing, and year. The subscriber projections must be supported by the results obtained from the market survey and analysis. It is the applicant's responsibility to clearly demonstrate how the market survey results support all subscriber projections, tiers, and pricing.

The spreadsheet has separate worksheets for IP Data, Video, and Voice Services. Applicants should use these tables to illustrate the broadband service offerings and subscriber counts for residential and business subscribers that are currently being provided (if applicable), and those proposed within the next five years. The tables break down subscribership into residential and business offerings. There is room for multiple service tiers for each classification and year-by-year estimates for subscriber counts in the first five years. Note that the subscriber numbers provided should be cumulative year-end counts, **NOT** the number of new subscribers added each year. Also note that subscribers who subscribe to more than one type of service should be counted on multiple tables. For example, a household that subscribes to both IP Data Services and Voice Services should be counted on both tables.

Definitions

- **Downstream:** Network traffic flow from main aggregation point - to the subscriber
- **Upstream:** Network traffic flow to main aggregation point - from the subscriber
- **Kbps:** Kilobit per second. 1000 kbps = 1 Mbps

- Advertised Tier Definitions - For each service offering to potential subscribers, enter the applicable downstream and upstream speeds.
 - You may change the “Tier Designator” label for each tier to provide the name for each tier, but this is not required.
 - Speeds are entered in kbps. Available tiers greater than 1 Mbps should be multiplied by 1000 to scale correctly. Example: A service tier offered at 5

Mbps downstream and 1 Mbps upstream would be represented as 5000 kbps and 1000 kbps, respectively.

- Currently Offered Service - Enter Y or N to indicate whether you currently offer this tier of service.
- Current Subscribers - For each tier, enter the number of current subscribers.
- Subscriber Projections (total End of Year [EOY]) - For each tier, enter the total number of subscribers who are anticipated to be subscribed to that tier at the end of each year of operation. This is a total number at that point in time and not an incremental number.
- Price - For each tier, enter the dollar amount charged to customers. In the case of bundled services, the price is the amount that would be charged for this service only.
- Wireless or Wireline? - For each service tier, indicate whether the service is a wireless or wireline offering.
- Last Mile/Middle Mile - For each service tier, indicate whether the offering is Last Mile or Middle Mile.

Pro Forma 5-Year Financial Forecast (Schedule M-4A)

Applicants are required to submit a complete financial model of the pro forma five year forecast period, and are strongly encouraged to use the Microsoft Excel spreadsheet template provided by RUS for Schedule M-4A. Applicants are allowed to modify this spreadsheet as long as any and all modifications are sufficiently explained.

The template includes three separate worksheets consisting of a pro forma Income Statement, Balance Sheet, and Statement of Cash Flows. The financial forecast must cover at least five years and be inclusive of ALL operations of the applicant, that is, both existing and proposed. It will be used by RUS to determine whether the loan can be repaid on its terms, whether the proposed project is financially feasible and sustainable, and whether this is a viable operation. The projections should be detailed, taking into account the applicant's best estimates for start-up costs (if any), revenues, expenses, ability to make a profit and all financial data related to any subsidiaries.

Tips for Successful Applications

- Ensure that the Schedule is prepared by a financial consultant, accountant, or individual qualified to prepare financial forecasts.
- Follow the guidance on developing financial projections in this section.
- Ensure that RUS can determine exactly how every line item was calculated in each forecast year.
- Ensure that the information you provide is consistent with the details of other sections in your application. This includes, but is not limited to:

- Schedule K – Research Data and Market Analysis
 - Schedule M-1 - Historical Financial Statements
 - Schedule M-2 - Schedule of Debt and Equity Funding
 - Schedule M-3 - Subscriber Projections and Service Tiers
 - Schedule P - Project Costs and Buildout Timeline
- Pro forma financial statements must be for the applicants and co-applicants, not for parent organizations.

General Pro Forma Financial Forecast Guidance

Every projection consists of an Income Statement, Balance Sheet, and Statement of Cash Flows. The statements must present three years of historical data (or as many years as the applicant has been in operation), and five years of pro forma forecast data. Columns should be clearly labeled with the appropriate year. Start-up organizations can leave the historical columns blank, except for the opening Balance Sheet, which should be included in the historical column immediately prior to the five-year forecast.

Historical and forecast years can be based on either calendar years or fiscal years, but if the applicant reports by fiscal years, the applicant should note the fiscal year period in the Pro Forma Financial Assumptions (Schedule M-4B).

The statements should also contain all of the applicant’s regulated and non-regulated operations. Revenues, expenses, assets, liabilities, and related cash flow transactions of non-regulated operations should be included in detail in the financial forecast and should not be reported net.

NOTE: The individual financial statements included in the RUS template for Schedule M-4A includes specific accounts which were used by Broadband Initiative Program (“BIP”) applicants to properly record the accounting effects of BIP grant revenue on the Income Statement, Balance Sheet, and Statement of Cash Flows. Applicants which were not Round 1 or Round 2 BIP awardees should disregard those BIP-specific accounts when presenting their financial data.

Pro Forma Income Statement Guidance

The Schedule M-4A template is pre-populated with preferred revenue and expense categories. Applicants are encouraged to use these exact categories in order to facilitate processing applications. If an applicant chooses to not employ this template, or otherwise modify the Schedule M-4A template categories, the applicant must provide a sufficient level of detail to enable a reasonable level of understanding of the financial position of the existing operations combined with operations derived from the proposed project.

The following is a brief description of the pre-populated revenue and expense categories contained on the Income Statement worksheet in this template.

REVENUES

- i. **Network Services Revenues**
 - a. **Local Voice Service** revenues are derived from the provision of local voice services to customers. Local voice service revenues should relate to the number of local voice service subscribers and price per subscriber information contained on Schedule M-2 - Subscriber Projections and Service Tiers. This should include revenue from residential, single-line businesses, multi-line businesses, and optional features.
 - b. **Broadband Data Service** revenues are derived from the provision of broadband data services to customers. Broadband data service revenues should relate to the number of subscribers and price per subscriber information contained on Schedule M-2 - Subscriber Projections and Service Tiers.
 - c. **Video Service** revenues are derived from the provision of video services to customers. Video service revenues should relate to the number of video service subscribers and price per subscriber information contained on Schedule M-2 - Subscriber Projections and Service Tiers. This should include basic, expanded basic, and digital subscribers, set-top box revenue, and premium channel packs and video on demand.
- ii. **Middle Mile Revenues** are derived from the provision of services related to a Middle Mile network, including transport and interconnection services. Middle Mile revenues should relate to the number of Middle Mile subscribers and price per subscriber information contained on Schedule M-2 - Subscriber Projections and Service Tiers.
- iii. **Network Access Service Revenues** are derived from the provision of exchange service to an interexchange carrier beyond the exchange carrier's network. These revenues are generated based on the interexchange carrier's minutes of use applied against access tariff rates.
- iv. **Universal Service Fund** revenues are funds received by the applicant from the various universal service fund programs.
- v. **Toll Service/Long Distance Voice** revenues are derived from the provision of toll/long distance services and should relate the minutes of usage applied against average rates per minute.
- vi. **Installation Revenues** are derived from the installation of network equipment, typically at a customer premises, that allows the provision of services. Installation revenue should relate to gross subscriber additions and proposed installation fees.
- vii. **Amortized Grant Revenue BIP:** BIP Awardees should account for revenue recognized from BIP grants as on their BIP applications. All other applicants should leave this section blank.

- viii. **Other Operating Revenues** are all other revenues derived from sources other than those described above.
- ix. **Uncollectible Revenues** are the estimated amounts of revenue that you will not be able to collect.

EXPENSES

- i. **Backhaul** expenses are associated with transporting voice and broadband data network traffic from the customer premises equipment (CPE) or handset to the point of interconnection to the Internet.
- ii. **IP/Interconnection** expenses are associated with interconnecting with and transferring traffic across the Internet.
- iii. **Video Content** expenses are related to the provision of video services revenue and consist of video programming costs and fees.
- iv. **Spectrum** expenses are related to leasing spectrum from others in a wireless services network. Amortized spectrum acquisition expenses related to purchased spectrum should be included in the *Amortization Expense* category described below.
- v. **Network Maintenance/Monitoring** expenses are the personnel and related costs of maintaining/monitoring the network and customer premises equipment.
- vi. **Utilities** expense is the cost of utilities related to network operations.
- vii. **Sales/Marketing** expenses are all costs associated with marketing to and obtaining customers and subscribers, including salesperson compensation, advertising and marketing promotions, and subsidies on customer premises equipment or handsets.
- viii. **Customer Care** expenses are the personnel and related costs of providing customer care operations to customers and subscribers.
- ix. **Corporate G&A** expenses include personnel, occupancy, insurance, billing and collections, and other general and administrative expenses.
- x. **Property Tax** expenses are the costs incurred for state and local property taxes.
- xi. **Other Operating Expenses** are all other operating expenses not included above.

EBITDA represents earnings before interest, taxes, depreciation, and amortization.

Depreciation - Project Assets is the depreciation expense related to all plant in service associated with the proposed Broadband Loan project.

Depreciation Other Assets is the depreciation expense related to the plant in service not associated with the proposed Broadband Loan project.

Amortization Expense is the amortization expense associated with intangible assets.

Interest Expense – Project Loan is the interest cost associated with Broadband Loan project requested as part of the application.

Interest Expense - Other Debt is the interest cost associated with the applicant’s other interest-bearing debt.

Interest Income is interest income earned from marketable securities and/or cash.

Income Taxes are the provision or benefit for Federal and state income taxes related to a for-profit applicant.

Net Income (Loss) represents the net income (loss) for the historical or forecast year.

TIER represents the times interest earned ratio of the applicant, and is calculated as follows:

(“*Net Income*” plus “*Interest Expense - Project Loan*” plus “*Interest Expense - Other Debt*”)

divided by

(“*Interest Expense - Project Loan*” plus “*Interest Expense - Other Debt*”)

Applicants requesting a Broadband Loan must achieve a TIER of 1.25 by the end of fifth year of the five-year financial forecast period.

Pro Forma Balance Sheet Guidance

The pro forma Balance Sheets must comply with basic GAAP requirements that Total Assets must equal Total Liabilities and Total Equity, and that loans are reflected with current and long-term positions for each pro forma year. The following is a brief description of the pre-populated balance sheet categories contained on the Balance Sheet worksheet in this template.

Assets

- i. **Cash** includes all restricted and non-restricted cash balances.
- ii. **Marketable Securities** consists of all short-term investments of excess cash not required for on-going operations.
- iii. **Accounts Receivable** consists of amounts owed by customers and subscribers from the provision of services or the sale of equipment.
- iv. **Inventory** consists of equipment available for project deployment or for sale to customers.
- v. **Other Current Assets** consists of all other current assets not included above, including, but not limited to, Notes Receivable and Prepayments.
- vi. **Amortizable Assets - Net** consists of intangible assets less related accumulated amortization.
- vii. **Plant in Service – Project Assets** contains the property and equipment at cost associated with the proposed Broadband Loan project. Annual changes to this category should relate to the *Capital Expenditures – Project Assets* category included on the Statement of Cash Flows.
- viii. **Accumulated Depreciation – Project Assets** consists of the accumulated depreciation of the proposed Broadband Loan project. Annual changes to this category should relate to the *Depreciation Expense – Project Assets* category included on the Income Statement.
- ix. **Plant in Service – Other Assets** contains the property and equipment at cost of assets *other than* the accumulated depreciation associated with the proposed Broadband Loan project. Annual changes to this category should relate to the *Capital Expenditures – Other Assets* category included on the Statement of Cash Flows.
- x. **Accumulated Depreciation – Other Assets** consists of the accumulated depreciation of assets included in the “Plant in Service –Other Assets” category. Annual changes to this category should relate to the *Depreciation Expense – Other Assets* category included on the Income Statement.
- xi. **Other Non-Current Assets** consists of all other non-current assets not included above.

Liabilities and Equity

- i. **Accounts Payable** consists of the amounts owed to trade vendors.
- ii. **Current Portion – Project Debt** consists of the total principal balance related to the proposed Broadband Loan project that will be repaid in the following year and should relate to the “Proceeds from Project Loan” and “Repayments of Project Loan” categories included on the Statement of Cash Flows.
- iii. **Current Portion – Other Debt** consists of the total principal balance related to all other of the applicant’s debt that will be repaid in the following year and should relate to the “Proceeds from Other Debt” and “Repayments of Other Debt” categories included on the Statement of Cash Flows.
- iv. **Current Portion – Deferred Grant Revenue BIP:** BIP Awardees should account for revenue recognized from BIP grants as on their BIP applications. All other applicants should leave this section blank.

This account consists of the total amount of deferred grant revenue that will be recognized as revenue in the following year and should relate to *Amortized Grant Revenue - BIP* category included contained on the Income Statement. However, those applicants that are rate-regulated Telecom or Electric companies must continue to utilize the accounting required by the respective uniform system of accounts for those industries, which require that the plant accounts be reduced by the grant funds received as the grant funds are received.
- v. **Other Current Liabilities** consists of all other current liabilities not included above.
- vi. **Broadband Project Debt** consists of the total outstanding principal balance related to the proposed Broadband Project loan, less the *Current Portion – Project Debt* category.
- vii. **Existing Other Debt** consists of the total outstanding principal balance of all other debt, less the *Current Portion - Other Debt* category.
- viii. **Deferred Grant Revenue BIP:** BIP Awardees should account for revenue recognized from BIP grants as on their BIP applications. All other applicants should leave this section blank.

This consists of the remaining unamortized grant revenue less the *Current Portion – Deferred Grant Revenue BIP* category. Rate-regulated Telecom or Electric companies may leave this item blank.
- ix. **Other Non Current Liabilities** consists of all other non-current liabilities not included above.
- x. **Capital Stock** consists of the par value of capital stock.
- xi. **Additional Paid in Capital** consists of all other capital stock transactions, less the amounts in *Capital Stock*.

- xii. **Patronage Capital Credits** represents earnings that have been designated for distribution to cooperative owners.
- xiii. **Retained Earnings** represent after-tax profits in the company. The changes from year to year must reconcile with the *Net Income* category included on the Income Statement.

Pro Forma Statement of Cash Flows Guidance –

The pro forma statement of cash flows must reflect the proposed Broadband Loan project funding and investments as well as any additional funding for working capital and other capital expenditures for the applicant exclusive of the Loan project. The following is a brief description of the pre-populated cash flow categories contained on the *Cash Flow* worksheet in this template.

Beginning Cash represents cash balances at the beginning of the period.

Cash Flows from Operating Activities:

- i. **Net Income (Loss)** is obtained from the *Net Income (Loss)* category on the Pro Forma Income Statement.
- ii. **Adjustments to Reconcile Net Income (Loss) to Net Cash Provided from Operating Activities:**

- a. **Depreciation – Project Assets** is obtained from the *Depreciation – Project Assets* category on the Income Statement.
- b. **Depreciation – Other Assets** is obtained from the *Depreciation – Other Assets* category on the Income Statement.
- c. **Amortization** is obtained from the *Amortization* category on the Income Statement.
- d. **Amortized Grant Revenue BIP** is obtained from the *Amortized Grant Revenue* category on the Income Statement. Rate-regulated Telecom or Electric companies and applicants which are not BIP awardees may leave this item blank.

Changes in Assets and Liabilities:

- i. **Accounts Receivable** is the net change in the *Accounts Receivable* category on the Balance Sheet.
- ii. **Inventory** is the net change in the *Inventory* category on the Balance Sheet.
- iii. **Other Current Assets** is the net change in the *Other Current Assets* category on the Balance Sheet.
- iv. **Other Non-Current Assets** is the net change in the *Other Non Current Assets* category on the Balance Sheet.

- v. **Accounts Payable** is the net change in the *Accounts Payable* category on the Balance Sheet.
- vi. **Other Current Liabilities** is the net change in the *Other Current Liabilities* category on the Balance Sheet.
- vii. **Other Non Current Liabilities** is the net change in the *Other Non Current Liabilities* category on the Balance Sheet.

Cash Flows from Financing Activities:

- i. **Proceeds from Sale of Equity** are the cash proceeds from the sale of Capital Stock.
- ii. **Proceeds from Project Loan** are the cash loan proceeds received under the proposed Broadband Loan project.
- iii. **Proceeds from Other Debt** are the cash proceeds received from other sources of debt. BIP awardees should include BIP debt in this category.
- iv. **Proceeds from BIP Grant** are the cash grant proceeds received under a BIP award. Applicants which are not BIP awardees can disregard this category.
- v. **Repayments of Project Loan** are the cash repayments of principal related to the proposed Broadband Loan project.
- vi. **Repayments of Other Debt** are the cash repayments of principal related to Other Debt.
- vii. **Payments of Patronage Capital Credits** are the cash payments made to the owners of cooperative associations.
- viii. **Payments of Dividends** are the cash payments of dividends to the owners of capital stock.

Cash Flows from Investing Activities:

- i. **Capital Expenditures – Project Operations** are the cash payments related to acquiring *Plant in Service – Project Assets*.
- ii. **Capital Expenditures – Other Operations** are the cash payments related to acquiring *Plant in Service – Other Assets*.
- iii. **Additions to Amortizable Assets** are the cash payments made to acquire amortizable assets.
- iv. **Change in Marketable Securities - Net** represents the net change in the *Marketable Securities* category of the Balance Sheet.

Ending Cash represents cash balances at the end of the period and should agree with the *Cash* category of the Balance Sheet.

Pro Forma Financial Assumptions (Schedule M-4B)

Overview: Applicants are required to submit a detailed written narrative that documents the various pro forma financial assumptions used to prepare the Pro Forma 5-Year Financial Forecast.

Every category in the pro forma financial statements must be explained with clear details so that RUS may review and understand the basis for the financial projections. The assumptions must allow an RUS financial analyst to re-create the pro forma financial statements. If the financial forecast is not fully supported by a detailed narrative for every category, it may affect the final decision on the application.

Guidance Related to the Pro Forma Financial Assumptions

While applicants are not required to utilize all of the categories in the worksheets, applicants must provide a sufficient level of detail to provide a reasonable understanding of existing and proposed operations, including the proposed Broadband Loan project. Any modifications to the pro forma financial statements submitted as Schedule M-4A must adequately document, support, and justify the information in any modified categories.

Historical Financial Reconciliation

If there are any gaps or discrepancies between the submitted historical financial statements and the historical data provided in Schedule M-4A, applicants should include detailed explanations in the assumptions.

Income Statement Assumptions

Applicants must provide assumptions for **ALL** of the categories on the Income Statement. Guidance for documenting assumptions about most specific categories is provided below.

REVENUES	GUIDANCE
Local Voice Service	Document the number of local voice service subscribers and average revenue per subscriber (ARPU) information used in determining local service revenue.
Broadband Data Service	Document the number of broadband data subscribers and average revenue per subscriber (ARPU) information used in determining broadband data revenue.

REVENUES	GUIDANCE
Video Service	Document the number of video service subscribers and average revenue per subscriber (ARPU) information used in determining video services revenue.
Middle Mile Revenues	Describe the forecasted Middle Mile revenue in detail.
Network Access Service Revenues	Document the interexchange carrier’s historical and projected minutes of use by category and the projected access tariff rates.
Universal Service Fund	Document the basis for receiving such funding.
Toll Service/Long Distance Voice	Document the historical and projected toll/long distance minutes of use by category and the proposed toll/long distance rates.
Installation Revenues	Document the related gross subscriber additions and proposed installation fees.
Amortized Grant Revenue BIP	Indicate the period of time over which the grant revenue is being amortized. This is explained in the “Grant Accounting” definition in the Definitions section of this Application Guide. Rate regulated Telecom or Electric companies may leave this item blank.
Other Operating Revenues	Document any assumptions related to other operating revenues, with justification to support the projected revenues.
Uncollectible Revenues	Document the rate used to estimate uncollectible revenues, with justification to support the projection.

EXPENSES	GUIDANCE
Backhaul/Interconnection/ Video Content/ Spectrum Expenses	Document how these costs are calculated and projected. Include capacity as it relates to costs – see guidance below:

The detailed network plan should link to the pro forma financial statements. Applicants should describe existing capacity and give its annual cost for backhaul, IP/interconnection, and/or spectrum and video. Include proposed capacity that will be necessary to serve subscribers as well as projected annual cost. Ensure that the annual cost totals for each category reconcile with the corresponding expense items.

Backhaul should include all transport costs for taking the applicant's network traffic to its providers. IP/Interconnection should include all IP traffic costs for providing service to users. Spectrum should include all spectrum costs for providing service to users (if applicable). Video content should include all costs associated with the provision of TV content to users (if applicable). Growth in these costs should generally correspond to projected subscriber growth for each of the various services, as applicable.

EXPENSES (continued)	GUIDANCE
Network Maintenance/ Monitoring Expenses	Document how these expenses are calculated and projected.
Utilities Expense	Document how these expenses are calculated and projected.
Sales/Marketing Expenses	Document how these expenses are calculated and projected.
Customer Care Expenses	Document how these expenses are calculated and projected.
Corporate G&A Expenses	Document how these expenses are calculated and projected.
Other Operating Expense	Document in detail any assumptions related to other operating expenses.
Interest Expense - Project Loan	Document the interest rate assumed for the proposed Broadband Loan Project.
Interest Expense – Other Debt	Document the interest rate(s) assumed for all other existing and proposed debt incurred by the Applicant. Ensure that this figure includes all debt included on Schedule M-2.

Balance Sheet Assumptions

Applicants must provide assumptions for **ALL** of the categories on the Balance Sheet. Guidance for a few specific categories is provided below.

BALANCE SHEET CATEGORY	GUIDANCE
Cash	Cash should tie to the <i>Ending Cash</i> category from the <i>Existing and Project Cash Flow</i> worksheet. Describe any restricted portions of cash balances.
Marketable Securities	Document the nature of the marketable securities and discuss liquidity of these.
Accounts Receivable	Document the calculations used to determine accounts receivable, including the number of days of outstanding revenue.
Inventory	Identify types of inventory, detail inventory balance and assumptions for how many days inventory will be maintained.
Accounts Payable	Document the calculations used to determine accounts payable, including the number of days of outstanding expenses.
Capital Stock and Additional Paid in Capital	These should consist of the contributed equity of the applicant plus any <i>Proceeds from Sale of Equity</i> from the <i>Existing and Project Cash Flow</i> worksheet.

Statement of Cash Flows Assumptions - The Cash Flow statement should tie to the net change in the various categories from the Balance Sheet. Net Income in each year should come directly from the Income Statement. Guidance concerning what should be included in the assumptions is outlined below.

CASH FLOWS FROM FINANCING ACTIVITIES	GUIDANCE
Proceeds from Sale of Equity	Ensure that amounts listed here relate to those in Schedule M-2 and M-5, if applicable.
Proceeds from Project Loan	Ensure that proposed Broadband Loan project draws match the network build-out schedule and “Capital Expenditures – Project Assets”
Proceeds from Other Debt	Ensure that amounts listed here relate to those in Schedule M-2 and M-5, if applicable.
Repayments of Project Loan	Document the repayment terms assumed (interest rate and repayment periods) in the determination of repayments of the proposed Broadband Loan.

CASH FLOWS FROM FINANCING ACTIVITIES	GUIDANCE
Repayments of Other Debt	Document the annual principal repayment requirements associated with repayments of all other debt, and account for all debt listed on Schedule M-2.
Payments of Patronage Capital Credits	Document the planned annual payments of patronage capital credits.
Payments of Dividends	Document the planned annual payments of dividends.

CASH FLOWS FROM INVESTING ACTIVITIES	GUIDANCE
Capital Expenditures – Project Assets	Ensure that proposed Broadband Loan project expenditures match the network build-out schedule and “Proceeds from Project Loan”
Capital Expenditures – Other Assets	Document the assumptions regarding capital expenditures for assets other than those being funded with the proposed Broadband Loan.
Additions to Amortizable Assets	Document planned payments for purchased spectrum or other amortizable assets.
Ending Cash	Ending cash represents the applicant’s cash balances at the end of the period and should agree with the <i>Cash</i> category of the Balance Sheet.

Additional Financial Assumption Considerations

Customer Premises Equipment (CPE): One of the eligible Broadband Loan project costs is for the acquisition of CPE (and associated installation costs), as long as the CPE is owned by the applicant throughout its economic life. **However, if an Applicant does not intend to retain ownership of CPE,** the Applicant must **select one** of the following alternatives allowed under 7 CFR 1738.52(e) in order to secure Broadband Loan funding for CPE:

- Pledge Additional Collateral: Provide a complete description and supporting information, sufficient for RUS to determine the value and to prepare documentation to secure RUS’s collateral interest. This collateral cannot be assets purchased with the loan funds and it must have a value at least equal to the amount being used for the CPE and associated installation costs.

- **Describe Revolving Fund:** Provide a description of how the applicant will administer a revolving fund for the purchase of the CPE and the sale of CPE to the customer. The description should provide a quarterly estimate of advances used for purchases, sales/collections used for revolving fund reductions, and the resulting balance on a quarterly basis.

Acquisitions: For broadband loans that include proceeds to acquire facilities, provide satisfactory evidence for RUS to determine that the acquisition is necessary and incidental to furnishing or improving service at the broadband lending speed in rural areas. Applicants must submit an appraisal, for the facilities to be acquired, from a qualified entity to determine the reasonableness of the acquisition price. This appraisal should be attached to Schedule P, Project Capital Investment Workbook. See 7 CFR 1738.51(c) for more information on eligible acquisition costs.

Refinancing: For broadband loans that include proceeds to refinance an outstanding telecommunications loan made under the Rural Electrification Act of 1936, provide satisfactory evidence for RUS to determine that the benefits realized from the refinancing will further enhance services at the broadband lending speed in rural areas. The amount requested for refinancing cannot exceed 40 percent of the requested loan amount. The applicant should also include the details of the notes that are being proposed to be refinanced. See 7 CFR 1738.51(d) for more information on eligible refinancing conditions.

Additional Cash Requirement (Schedule M-5)

In addition to the minimum equity requirement, additional cash infusions may be required, regardless of whether or not the applicant has demonstrated positive cash flow from operations for the two years prior to application submission. RUS will analyze the applicant's financial information for the applicant's entire operation (existing operations and new operations combined) and determine the applicant's projected cash balance at the end of each fiscal year during the five-year forecast period. If RUS projects that the applicant will have a negative cash balance during any of those fiscal year-end dates, the applicant will be required to obtain additional cash infusions necessary to maintain a positive cash balance throughout the five-year forecast period (see 7 CFR 1738.208).

To facilitate the timely processing of the application, applicants should conduct their own analysis to identify projected cash shortfalls and provide the resources to cover those amounts. Additional resources should be shown in the Schedule of Debt and Equity Funding (Schedule M-2). When preparing financial projections, applicants are to consider RUS's regulatory requirements for how projected revenues will be calculated for start-up firms or for companies that have not had positive cash flow for the two years prior to application submission.

If an applicant is a start-up company or has not had positive cash flow for the two previous fiscal years, the applicant must calculate the cash position when assuming 50

percent of projected revenues for each year of the five-year forecast period (no comparable adjustment is made to projected expenses).

Applicants that are required per the above regulatory requirements to adjust their projected revenues must submit, for Schedule M-5, a modified version of the financial projections used in Schedule M-4A which reflects a 50 percent reduction in projected revenues, to identify the amount of additional cash that will be required. In all cases, projections must be fully supported with assumptions acceptable to RUS.

If necessary, an applicant may obtain a Letter of Credit (LOC) to satisfy an additional cash requirement, though an LOC is not considered equity and cannot be used to meet the 10 percent equity requirement. If an applicant obtains an LOC, it must be in place prior to loan closing, and it must meet the following terms:

Terms for the Bank

- Investor to enter into LOC to benefit the applicant and the Government. The LOC cannot be an obligation of the applicant, cannot be secured by the applicant's assets and the LOC fees and charges cannot be paid by the applicant.
- LOC to be irrevocable permitting unconditional draws by the applicant and the Government.

Terms for the Applicant

- These terms will be included as a condition to the Loan Agreement
- LOC must be in effect throughout the forecast period.
- The applicant cannot secure the LOC with its assets and cannot pay for any LOC charges or fees with its funds.
- Applicant agrees to draw on the LOC if the quarterly financial reports show a negative cash balance, in an amount sufficient to cover the shortfall. Note that the need for the Additional Cash Requirement is determined by a review of the **annual** financial projections but the requirement to meet the Additional Cash Requirement is determined by a review of the **quarterly** actual financial statements.
- Applicant agrees to draw on LOC when directed by RUS.
- Failure to maintain the LOC will be an Event of Default.

When additional cash is required to cover a projected cash shortfall, the applicant must ensure that the additional cash infusion required in the first two years is deposited into its regular operating bank account within 120 days from the date the applicant concurs with the loan offer letter. Prior to closing, the applicant also must enter into any other legal arrangements necessary to cover further projected operating deficits to RUS's satisfaction (or in the case of the LOC, provide an acceptable LOC to the Agency). If debt is incurred to satisfy the additional cash requirement, this debt must take a subordinate lien position to the Agency debt and must be at terms acceptable to the Agency.

Depreciation Schedule (Schedule M-6)

A projected depreciation schedule should be submitted as Schedule M-6. Applicants are strongly advised to use the template provided by RUS for this Schedule. However, applicants may add rows or otherwise provide additional information in this Schedule, though the applicant must fully explain any and all modifications. This schedule should include all categories of depreciable equipment and facilities that are proposed for purchase through Broadband Loan Project funds only.

The economic life of each asset category should be based on the manufacturers' recommended useful life, and the applicant must submit justification for the useful lives of each asset category. RUS, in its sole discretion, will determine whether the applicant's asset depreciation rates are acceptable. RUS will calculate the expected composite economic life of Broadband Loan Project-funded assets based on those acceptable depreciation rates.

Applicants should note that this composite economic life has important implications for financial statement presentation and loan feasibility. Applicants cannot request a loan term that exceeds the composite economic life of project assets funded by a Broadband Loan. As a result, the Pro Forma Financial Forecast must reflect a loan amortization which is less than or equal to the composite economic life of the Broadband Loan-financed assets.

Applicants must also show a breakdown of the dollar amounts of each asset category to be installed over the three-year build-out timeline. This information must match information provided in the build-out timeline as part of the Project Capital Investment Workbook (Schedule Q).

Instructions for Preparing Schedule N

NETWORK DESIGN (Schedules N-1 through N-3)

The Network Design of the application shall include all the technical information on the applicant's existing and proposed systems. The following information shall be included in this schedule:

- A. Schedule N-1 shall present a Network Design with the following information:
 1. A detailed description of the existing network (if applicable). Provide a synopsis of the current network infrastructure, including:
 - a. The current service area(s)

- b. The types of services offered
 - c. The total number of establishments served:
 - i. Wireline establishments passed
 - ii. Wireless establishments covered
 - d. The number of subscribers per service offered (voice, data, video etc.)
 - e. The types of technologies utilized in the infrastructure (standards-based vs. proprietary)
 - f. A narrative describing current connectivity to the applicant's ISPs, video providers, and telephony providers.
2. A detailed description of the proposed network. Provide a synopsis of the proposed network infrastructure, describing the types of technology to be deployed in the funded service area and how the technology will facilitate the offering of service at the broadband lending speed. The synopsis should include:
- a. The entire service area(s) that will be provided new or improved service as part of the loan including how any new services area(s), if applicable, will be incorporated into the existing system and any upgrades that will be made to the existing infrastructure.
 - b. The types of services to be offered.
 - c. The estimated number of establishments to be served (provide detailed information showing that all households within the funded service area will be offered broadband service at the broadband lending speed when the system is complete):
 - i. Wireline establishments to be passed
 - ii. Wireless establishments to be covered
 - d. The estimated number of subscribers per service offered (voice, data, video etc.)
 - e. The types of technologies to be employed in the infrastructure (standards-based vs. proprietary)
 - f. A narrative describing proposed connectivity to ISP's, video providers, telephony providers, and other content providers including any changes to the existing system, if any.
 - g. A description of the design parameters used in engineering the system. Examples include oversubscription percentage, consumption of bandwidth per user, penetration rates, link loss, availability targets, redundancy requirements, and criteria for candidate vendors
 - h. Address any other subject areas necessary to make as thorough a disclosure as possible, so that network capacity, performance, user loading, technology strengths and weaknesses, etc. can be fairly assessed.
3. A description of the licenses and agreements that will be required to operate the network. This will supplement Schedule S.

4. A detailed description of the proposed Build-out of Services for the proposed network services. The description should include the approach taken to phasing in, testing and commissioning the following elements of the infrastructure:
 - a. The Core Network – the backbone infrastructure that will deliver the aggregate services across the service area(s).
 - b. The Distribution Network – the next layer of infrastructure that will extend the Core Network to concentration points within geographically proximate groups of subscribers.
 - c. The Access Network – how individual subscribers gain access to the network infrastructure. This should include detail on how oversubscription techniques (if applicable) will be used to maximize the utilization of the Distribution Network.
 - d. The Aggregation Node Points. In this context, the Aggregation Node Points are those components of the network architecture that provides connectivity to other service or content providers used to deliver the proposed services. This may include, but is not limited to, high-capacity diverse and resilient access to:
 - i. One or more Internet Service Providers (ISPs)
 - ii. VOIP and PSTN Telephony Service Providers
 - iii. Video Services (if applicable)
5. If the applicant is to include Customer Premises Equipment (CPE) as part of their service offering to customers, please provide a description of the proposed CPE, and the method of acquisition by the customer (e.g. this could include rental as part of the service offering, or a one-time purchase by the customer).
6. A description of target service level objectives (SLOs) that will be provided to the customer and measurable service metrics that will be gathered and how they will be utilized on an ongoing basis to respond to unmet SLOs and ensure customer expectations of network service availability, reliability and quality. You must provide a detailed disclosure of the proposed network management and monitoring systems, as well as a description of the operational practices you plan to implement to ensure quality and consistency in providing services to customers. A sample form is provided as Schedule N-2 “Service Metrics and Network Management” that is to be filled out which lists a series of service categories, each with corresponding criteria that you must explain. Categories may have multiple entries if you plan multiple unique metrics. The general categories include:
 - a. Customer Service - The customer-facing aspects of the business required to maintain satisfied customers. Examples include but are not limited to providing customer service centers and providing secure online bill-pay.

- b. Order Fulfillment - The operational or back office aspects of running the day-to-day business. Examples are the Provisioning Process, the use of workforce management and scheduling tools in order to meet appointment windows, responding to Change of Service requests in a timely manner, etc.
- c. Capacity Planning - The proactive processes and allocation of resources necessary to maintain, improve, or expand the capabilities of the network. Examples include ensuring that performance objectives are met, ensuring that resources are scheduled to accommodate subscriber growth, analyzing network utilization, and developing techniques to mitigate or prevent network congestion.
- d. Network Management - The activities involved in monitoring, reporting, and analyzing events, alarms, or any network-originated data, in order to spur preventive or corrective action, so that availability or performance levels of the network may be maintained or improved. Examples are capturing and archiving performance data, using polling devices, using Network Management systems for outage response, and using systems to report the number of alarms on a network, etc.

You are urged to independently develop a list of Target Objectives, Constraints, Triggers, and Systems and Tools that align with your organization's business or operational processes. You are not constrained by the space or form provided and may provide as much detail as is necessary to depict the vital aspects of each general category.

Within each of the categories Schedule N-2 "Service Metrics and Network Management" asks you to provide a narrative description of the planned service, whether the service will be outsourced, and how each service will be provisioned and operationalized.

For each described service within a category, be sure to include:

- a. Target Objectives - The current or planned business or operational process to support the activity being described. Should reflect reasonable means by which to determine whether the described service is performing within expectations.
- b. Constraints - Further refine the Target Objectives to describe exclusions or limitations, or define upper and lower boundaries. Examples include answering 90 percent of calls within 30 seconds, installing new service within 48 hours of request, maintaining less than 80 percent circuit utilization, targeting no more than 4 hours of downtime for more than three subscribers affected by a single outage, etc.
- c. Triggers - Note specific boundaries or limits placed on measurements of performance indicators. Triggers spur preventive or corrective action in support of the Target Objective. Examples include management

notification if greater than 50 calls per day are not answered, provisioning an additional circuit if utilization trends above 75 percent for 7 consecutive days, or responding to a single event that affects three or more customers, etc.

- d. Systems and Tools - List systems and tools that support the accomplishment of the objective. Examples include Automatic Call Distribution System, private branch exchange (PBX), workforce management software, Trouble Ticketing Systems, vendor-specific Network Element Monitoring, etc.
- e. Provider - Whether the proposed service is to be performed by an outside contractor or internally within the company.

B. Schedule N-3 shall present a Network Design Certification as follows:

1. The Network Design may be prepared by qualified personnel on the applicant's staff or by consultants.
2. If the applicant chooses a consultant that is not a registered engineer licensed in the state in which the facilities will be constructed, the applicant will need to have a registered engineer, licensed in the state, certify that the proposed Network Design will be capable of delivering service at the broadband lending speed.
3. Consulting services shall be obtained only from persons or firms who are not affiliated with, and have not represented, a contractor, vendor or manufacturer who may provide labor, materials, or equipment to the applicant for projects included in the loan application.
4. If the applicant has qualified personnel on staff to complete the pre-loan services, copies of the staff's qualifications must be included here in Schedule N-2 as part of the application and must clearly demonstrate the staff's ability to certify the Network Design. To be considered qualified, staff must have at least three years of experience in designing the type of broadband system proposed in the application.
5. The applicant will complete and include the attached template "Network Design Certification."

Instructions for Preparing Schedule O

[NETWORK DIAGRAMS \(Schedules O-1 and O-2\)](#)

Network diagrams for the applicant's existing network shall be included in the application as Schedule O-1 and for the proposed network as Schedule O-2. The network diagrams shall be block diagrams that clearly show how the traffic flows through the network from the interconnection points with the backbone service providers to the end user. The lender is familiar with the technologies associated with "last mile" connectivity options to the customer premises; therefore, in developing diagrams for the proposed network, focus should be on the core network (common network facilities) components.

The diagram(s) must clearly show:

- a. All physical locations where the major network elements are or will be located to the highest known level of detail. This may take the form of postal addresses or latitude and longitude
- b. The route miles between each network element
- c. The bandwidth capacity between the network elements
- d. The types of facilities (fiber, copper, microwave, etc.) that are or will be used for establishing the connection between the network elements and the points-of-connection with the backbone service providers
- e. The proposed facilities that will provide the interconnection point(s) from the broadband backbone network to the networks of the selected ISP(s), telephony and/or VOIP provider(s), and any other value-added services that may be provided in the new infrastructure
- f. Any leased facilities, along with the location of the leased facilities (postal addresses or latitude and longitude) and the providers from which the facilities are being leased
- g. For Network Diagrams where the level of factual detail to be provided will inhibit the overall understanding of the diagram, applicants may provide a table at the bottom of the diagram providing the remaining technical details to the extent currently known

There is no template for the Network Diagram, but the Appendix at the end of this Application Guide contains examples of Network Diagrams for the following technologies: Passive Optic Networks (PON), DSL, Hybrid Fiber-Coaxial (HFC), Radio Frequency over Glass (RFOG), and Terrestrial Wireless. Note that the example Network Diagrams do not display every home or premises passed but will indicate the typical number of connections reaching to each node (as represented with the letter n). Also note that these sample diagrams are for illustrative purposes only, and are not intended to construe or imply any design characteristics or requirements for a proposed system.

Instructions for Preparing Schedule P

PROJECT COSTS AND BUILDOUT TIMELINE (Schedules P)

For this section, fill out the provided attachment Schedule P “Project Capital Investment Workbook.” This attachment will provide detailed information on the project capital investment, including detailed project costs, your build-out timeline, and project milestones. Note that the template for this attachment consists of three worksheets consolidated within one workbook as follows. Be sure to complete all three.

- a. Detailed Project Costs - The purpose of the Detailed Project Cost Schedule is to break down the specific costs involved in your project and categorize them. This section should be filled out per Service Area with common network elements included with the Service Area in which they will be physically located.

Enter a descriptive name for each capital item or group of items in the appropriate category. This information should be prepared by Service Area, with common network elements included in the Service Area in which they are physically located. Identify common network elements by selecting “Yes” in the “Common Network Element?” column. Use the Unit Cost and Number of Units fields to further break down the costs. When multiple items are included in one “unit,” use the description column to provide enough detail that the reviewers can easily see how you arrived at that unit cost (you may also provide supplemental attachments as necessary). The following information is provided as a guide to the various budget categories:

- ✓ Network & Access Equipment Costs: Examples of items to include are next-generation switches, video headends, optical equipment, digital line concentrators, digital subscriber line access multiplexers, middleware, video-on-demand equipment, radio equipment, data routing equipment, etc.
- ✓ Outside Plant Costs: Examples of items to include are cable (aerial, buried, underground, and submarine), conduit systems, poles, network interface devices (NIDs, not including ONT’s or other powered access equipment), miscellaneous construction units, make-ready costs for aerial plant, etc.
- ✓ Tower Costs: Include the cost for the construction of new towers and any costs involved with structural changes to existing towers. Site engineering and project management costs should not be included in this category; they should be included under the Professional Services category.
- ✓ Building and Land Costs: Include the cost of constructing new buildings and renovating existing buildings, as well as any site

preparation cost involved with installing pad-mounted equipment. Include only those sites that you will purchase.

- ✓ Customer Premises Equipment: Examples of items to include are wireless subscriber units, modems, set-top boxes, etc.
- ✓ Billing and Operational Support Systems: Examples of items to include are billing, customer, and other support systems.
- ✓ Operating Equipment: Include items such as vehicles, furniture, and other operating equipment.
- ✓ Professional Services: Include engineering costs involved in designing and constructing the proposed project, consultant services, and project management.
- ✓ Testing: Include items such as testing network and IT systems, user devices, servers, as well as lab furnishing and test generators.
- ✓ Other Upfront Costs: Include any other upfront costs not covered in the other categories, such as site preparation.

b. Build-out Timeline - The purpose of this worksheet is to summarize the funding and workforce for the total capital plan over a 5-year period. In the next worksheet you will identify key phases and milestones to demonstrate the degree of completion, but in this worksheet you enter the incremental capital project costs spent by quarter. Ensure that the data in this attachment ties directly to the application pro forma financial statements in terms of timing, cash flows, revenue assumptions, and capital expenditures. Use incremental numbers for funds spent in each quarter without rounding. Note that total funds in this table should equal both the **Detail Project Cost** on the previous worksheet. Construction must start within six months of loan fund availability and be complete within three years of loan fund availability (Year 3 on this worksheet).

In the Workforce section of the timeline, enter a description of the workforce that will be used to complete the project in column A, followed by the incremental number of workers in that workforce by year.

c. Project Milestones - Use this table to list the major network build-out phases and milestones that can demonstrate that your entire project will be fully complete by the end of Year 3. This is to be done at the aggregate level (combining all PFSAs in your application).

Indicate how the milestones listed will demonstrate these completion objectives. You should consider such project areas as a) network design; b) securing all relevant licenses and agreements; c) site preparation; d) equipment procurement; e) inside plant deployment; f) outside plant deployment; g) equipment deployment; h) network testing; and i) network both complete and operational. You may provide any other milestones that you believe will showcase progress.

- i. Project inception (Year 0) starts when the applicant closes on the Broadband loan.

- ii. In the table, provide any information, including facts and analysis, to: a) demonstrate the reasonableness of these milestones; and b) substantiate the ability to reach the milestones by the quarters indicated.
- iii. If more bullet points are required, insert rows as needed within a given year. However, the project must be complete within 3 years of receiving the award.
- iv. In the space provided, describe the key challenges, if any, to a timely completion of the project, including any applicable mitigation plans.

Refer to the top of each worksheet for further instructions on filling out the worksheets in this workbook.

Instructions for Preparing Schedules Q & R

[ENVIRONMENTAL REPORT \(Schedule Q\)](#)

RD is responsible for implementing the requirements of the National Environmental Policy Act of 1969 (NEPA), as amended; the Council on Environmental Quality Regulations for Implementing the Procedural Provisions of NEPA and certain related Federal environmental laws, statutes, regulations, and Executive Orders (EO) that apply to RD programs. The policies and procedures set forth in 7 CFR Part 1794 – Environmental Policies and Procedures, assist RD with making decisions that are based on an understanding of environmental consequences, and taking action that protects, restores and enhances the environment.

Applicants are responsible for ensuring that proposed actions are in compliance with all appropriate RD requirements. Therefore, applicants must prepare an environmental report in accordance with 7 CFR Part 1794, for any facilities that will be constructed with RD broadband loan funds. A copy of 7 CFR Part 1794 can be retrieved from RD's web site.

The link for this regulation is <http://www.usda.gov/rus/water/ees/pdf/1794.pdf> . In addition, applicants can also retrieve the *Guide for Preparing an Environmental Report for Categorically Excluded Projects* to assist in the preparation of the Environmental Report. The link for this guide is http://www.usda.gov/rus/telecom/publications/word_files/1794a600.doc.

LICENSES AND AGREEMENTS (Schedule R)

1. Fill out the attached template for Schedule R “Licenses and Agreements”. You must provide a status report for the licenses, agreements, approvals, and authorizations potentially required for constructing your broadband network, and indicate their status. In the template you must select a status for every item in the table and add comments where needed. The statuses include:
 - a. Not Required - Place an “X” in this column to indicate an item that will not, at any point, require this license, e.g., FCC Spectrum Licenses for a wireline provider.
 - b. Existing/In-Hand - No Modifications Necessary - Place an “X” in this column to indicate agreements that are completed, in-hand, and ready to be acted upon. For example, most wireline incumbents with existing operations in a proposed funded service area will already have their Certificate of Public Convenience and Necessity in hand.
 - c. Existing/In-Hand - but Modifications Required - Place an “X” in this column to indicate existing agreements that will require modifications, such as backhaul agreements for an incumbent that need to be increased in capacity.
 - d. Applied but Pending - Place an “X” in this column to indicate licenses that have been duly applied for, but for which you are awaiting confirmation and/or approval.
 - e. Contingent on Award - Place an “X” in this column to indicate an agreement that may exist and be finalized, but which is written to be valid only if you receive an award.
 - f. Not Available until Project is Funded - Place an “X” in this column for agreements that cannot be completed until you either have confirmation of winning the government award or have received the first disbursement.

To the right of the status of the agreement or license there is a column for comments. In this column, be sure to add contextual information that is relevant to the ownership and availability of the license or agreement. For example, be certain to indicate whether an asset is owned or will be owned by a parent company or organization, if (in the case of spectrum) it is being leased to the applicant, and on what basis (exclusive, non-exclusive, time-limited) this lease is being made.

Note that you must attach the supporting documentation for existing licenses and agreements to the application. You must include the sections of these licenses and agreements which indicate the terms (including capacity and cost) for those licenses and agreements that are already in hand. Licenses, agreements, approvals, and authorizations include:

- a. Internet Service Agreement - An agreement between an Internet Service Provider (“ISP”) and a retail reseller of Internet services (usually the applicant). This

generally includes details regarding facilitating, provisioning, transporting, and maintaining a fixed or variable amount of payload traffic (a.k.a., bandwidth) from one or more locations to an ISP's portal.

- b. Internet Service Connection Backhaul Agreement - The agreement governing the physical link connecting an applicant's network to the ISP's facilities. In some cases, this agreement will be part of the Internet Service Agreement, and in other cases it will be separate.
- c. Pole Attachment Agreement - An arrangement between the owner of the pole, usually a power or phone company, and an operator who wants to lease the right to attach fiber strand (for example) so that they may construct infrastructure more cost effectively than performing underground construction.
- d. Wireless Spectrum Licenses (end-user access) - The legal right to transmit on a specific frequency to CPE devices for the transport of communication services.
- e. Wireless Spectrum Licenses (for backhaul transport) - Wireless Spectrum Licenses for backhaul transport.
- f. Tower-Site/Property Agreements - Agreements governing the terms of use of any tower sites where an applicant intends to use or build its own facilities.
- g. Tower Attachment Agreements - Agreements governing the terms under which an applicant can attach and operate its equipment.
- h. Special Permits (federal, highway, bridge, etc) - Certain protected Federal Lands like National Parks, Historic Districts, or other protected or Federal government owned land require the following of a particular protocol in order to obtain permission to construct fiber optic infrastructure. Railroad Crossings or Bridge Crossings typically need to be coordinated with the State Department of Transportation.
- i. Franchise Agreements - An agreement that grants a network operator the right to construct in rights of way governed by the local franchise, usually the local municipality, and market for sale video services to paying subscribers in that local district.
- j. Video Carriage Agreements - A contract that authorizes a network operator to [re]transmit content. These can be obtained from content aggregators who offer entire channel lineups, or from individual broadcasters, production companies, etc.

k. Certificate of Public Convenience and Necessity (CPCN) - A Certificate of Public Convenience and Necessity (CPCN) is an authorization issued by the State Public Service Commission (PSC) for the delivery and/or provision of a public service to a designated area or parcel of land. A CPCN is generally needed to permit building facilities in public rights of way and for certain types of commerce. CPCN rules and regulations vary by State.

l. Spectrum Agreements - *Spectrum agreements must show both capacity and cost.*

You are not constrained to the space provided and may add as many rows as is necessary to depict the full range of licenses, agreements, approvals, and authorizations involved in your project.

ATTACHMENT:

USOA ADDITIONAL ACCOUNT SUBCATEGORIES FOR BROADBAND SERVICE PROVIDERS

Accounting requirements for RUS Broadband Program borrowers parallel the accounting requirements for traditional telecommunications borrowers. This Uniform System of Accounts, based on the Federal Communications Commission's 47 CFR Part 32, Uniform System of Accounts, contains all of the accounts needed to account for Broadband Operations. The general instructions found in Subpart B are applicable to borrowers under the RUS Rural Broadband Access Loan and Loan Guarantee Program, regardless of whether they are traditional telecommunications borrowers or borrowers for the purpose of providing broadband services only. Broadband borrowers must understand that while not every account shown in Bulletin 1770 B-1 is necessary based on the size and complexity of the company, the underlying account structure is the same.

Asset accounts, other than fixed assets, are numbered from 1130 to 1500. These accounts include both current and noncurrent assets. Fixed assets, both tangible and intangible, which ordinarily have a service life of more than one year, are found in Accounts 2001 through 2007, with the detailed Telecommunications Plant in Service balances found in Accounts 2100 through 2690. Accounts 3100 through 3600 contain Accumulated Depreciation and Amortization related to the fixed assets found in Accounts 2100 through 2690 along with the Retirement work in progress (RWIP). Accounts 4000 through 4199 contain Current Liability balances while Accounts 4200 through 4299 include Long-Term Debt. Accounts 4300 through 4399 are used to account for Other Long-Term Liabilities and Deferred Credits. Stockholders' Equity balances are found in Accounts 4500 through 4599. Operating revenue accounts are found in Accounts 5000 through 5302. These accounts are intended to record the results of the company's major or central operations during the accounting period. These accounts contain both regulated and non-regulated revenues. Accounts 6000 through 6790 shall be used to record the expenses associated with the company's major or central operations. Again, these accounts contain both regulated and non-regulated expenses. Accounts 7000 through 7990 are designed to reflect both operating and nonoperating income items include taxes, extraordinary items and other income and expense items not associated with the major or central operations.

Expenses within this system of accounts are accounted for on a functional basis, that is, expenses are recorded based on the function they support regardless of the type of expense. See Subpart E, Instructions for Expense Accounts, for the detailed instructions for classifying expenses. The expense accounts shall be maintained by subsidiary record categories, as appropriate to each account. The expense matrix is provided to allow a company to capture this information for management purposes.

In addition to those items described in Bulletin 1770 B-1, this Attachment outlines those additional items to be included in these same accounts for other telecom companies such as Internet Service Providers, Cable TV companies, wireless companies, and any other

type of entity providing broadband services. This attachment is to be used in conjunction with 47 CFR Part 32, as supplemented by 7 CFR Part 1770, in setting up and maintaining accounts of RUS Telecommunications Program borrowers.

32.2112, Motor Vehicles

Examples of items to be recorded in this account include:

- Automobiles
- Tractor Trailers
- Trucks
- Vans
- Buses

32.2113, Special Purpose Vehicles

Examples of items to be recorded in this account include:

- Boats and barges
- Motor scooters
- Snowmobiles

32.2114, Tools and other work equipment

Examples of items to be recorded in this account include:

- Air compressors
- Backhoes
- Bulldozers
- Cable lashers
- Cable plows
- Car hoists
- Carts-cable splicers
- Concrete mixers
- Derricks
- Duct rodders
- Earth moving machines
- Fork lifts
- Garage jacks
- Gasoline pumps
- Heaters
- Hydraulic lubricated equipment
- Ladders
- Lubricating racks
- Machine tools
- Metal bins
- Oil pumps
- Paint spraying equipment
- Pole-treating apparatus - chemical
- Portable motors
- Portable test equipment
- Power blowers, hammers, drills, loaders and winches

- Power take-offs
- Power tools
- Pumps (except fuel and oil)
- Storage tanks (e.g., fuel oil)
- Tamping and back-filling machines
- Tents – cable splicers
- Tire changers
- Tire racks
- Tool boxes
- Torches
- Tractors
- Trailers, special purpose
- Trenching machines
- Welding equipment
- Wheel alignment equipment
- Work benches

32.2122, Furniture

Examples of items to be recorded in this account include:

- Antiques
- Artwork (Paintings, prints, photographs, sculptures, wall hangings, tapestry, etc.)
- Beds, cots & couches
- Bookcases
- Cabinets and filing cases
- Chairs
- Credenzas
- Desks
- Drapes, blinds, and shades
- Lamps
- Lockers and wardrobes – movable
- Modular furniture units
- Partitions – movable
- Refrigerators
- Rugs
- Sofas
- Tables

32.2123.1, Office Support Equipment

Examples of items to be recorded in this account include:

- Addressing machines
- Air conditioners – portable
- Audio/visual equipment
- Billing/posting machines
- CAD systems
- Calculators
- Cameras

- Check registers
- Cash registers
- Copy machines
- Humidifiers/Dehumidifiers – portable
- Display and lecture demonstrating kits
- Electric fans – portable
- Fire extinguishing equipment – portable
- Floor scrubbing and polishing machines
- Medical equipment
- Microfilm equipment
- Postage meter machines
- Radios and television sets
- Typewriters
- Vacuum cleaners
- Vending machines
- Water coolers – portable

32.2123.2, Company Communications Equipment

Examples of items that can be recorded in this account are:

- Data communications terminal equipment
- Distributing frames
- Fax Machines
- Fiber optic distribution systems
- Operators' headset and transmitters
- Telephone sets
- Mobile Phones
- Private Branch exchange
- Switching equipment at switching or relay centers of teletypewriter systems
- Teletypewriter systems

*Includes common equipment (power equipment, switching equipment, etc.), station equipment (usually telephones or key telephone systems), and wires connecting the common equipment and the station equipment plus the terminal boxes or cross connector points, and the cable or wires that connect that connect the private branch exchange with the network interface.

32.2124, General Purpose Computers

Examples of items that can be recorded in this account are:

- Desktop and Laptop computers
- Tape drives
- Uninterrupted power supply
- Printers
- Optical scanners
- Memory units
- External drives

- Modems
- Monitors
- Keyboards
- Mouse
- Microphones
- Speakers

RUS 2210.21, Central office switching – digital

Examples of items to be recorded in this account are:

- Digital central office switches
- Remote switches
- Next-generation switches including soft switches and IP switches
- Mobile switching offices
- Base station controllers
- Asynchronous Transfer Mode switches
- Automatic message recording equipment
- Call store equipment
- Central control and processing equipment including initial operating system software for computers classified to this account
- Controllers
- Direct memory access units
- Main distribution frames, arrestors, and protectors
- Furniture designed specifically for equipment included in this account
- Input/output devices including disk and tape drives, display and alarm units
- Plug-in units (line cards, circuit pack, line cards, etc.)
- Trunks
- Permits, privileges, and rights-of-way for installation of externally-mounted central office equipment
- Test equipment, hardwired or specifically designed and dedicated for use with a particular major switching system or component
- Power equipment (chargers, batteries, generators, etc)
- Timing equipment
- Automated Line Assignment equipment

RUS 2230.11, Central office transmission – radio systems-satellite and earth station facilities

Examples of equipment that can be recorded in this account are:

- Antenna systems
- Base band equipment
- Converters
- High power amplifiers
- Low power amplifiers
- Satellite receivers
- Satellites
- Satellite launch insurance premiums
- Special cost incurred in procuring launch insurance

Transceivers
Transmitters
Digital or analog video headend equipment
Test equipment hardwired or specifically designed and dedicated to be used with a particular major operator system or component

RUS 2230.12, Central office transmission – radio systems – other

Examples of equipment that can be recorded in this account are:
Base station equipment
Microwave equipment
Radio equipment that uses licensed or unlicensed frequencies
Antennae
Amplifiers
Combiners
Radio dispatch system with GPS
Radio frequency amplifiers
Receivers
Transmitters
Repeaters
Waveguides
Power equipment
Permits, privileges, and rights-of-way for installation of externally-mounted radio facilities
Test equipment hardwired or specifically designed and dedicated to be used with a particular major operator system or component

RUS 2230.21, Central office transmission – circuit equipment

Examples of equipment that can be recorded in this category are:
Digital line concentrators
Subscriber loop carrier equipment
Channel banks
Cabinets
Digital access cross-connect system
Channel bank equipment
SS7 signaling equipment
Signal Transfer points
Signal Control points
Signal processors and distributors
Analog to digital converters
Echo cancellers
Echo suppressors
Equalizers
Optical transmission equipment
Optical splitter and couplers
Digital subscriber line (DSL) cards
Line repeaters

Regeneration equipment
Multiplexing equipment including Digital Subscriber Line Access Multiplexers
Range or loop extenders
T1 transmission equipment
Gigabit Ethernet transmission equipment
Power equipment including chargers, batteries, etc
Voice grade amplifiers

32.2311, Station Apparatus

Examples of equipment that can be recorded in this category are:
DSL, cable and wireless modems
Video set-top boxes

32.2362, Other terminal equipment

Examples of equipment that can be recorded in this category are:
Routers
Optical line terminators
Optical/coaxial network units placed on the subscriber's premises
ADSL and VDSL gateways
Cable modem termination system
Middleware

32.2411, Poles

Examples of equipment that can be recorded in this category are:
A and H fixtures
Anchors
Arms – cable, extension, guard and crossarms
Auxiliary framework for towers
Bolts, braces, and brackets
Guy clamps, shields, wire or strand
Path surveys
Bridge fixtures
Permits, privileges, and rights-of-way for construction
Pins
Pole and pole steps
Strain insulators
Stubs – guy or pole
Supports – radio antennae, such as wood poles or wood pole towers
Treating and marking poles
Towers – aluminum, wood, or steel; guyed or free standing

5000, Local Network Service Revenues

Examples of revenues that can be recorded in this account include:
Dial-Up Internet Service Revenue
Voice-Over-IP Revenue
xDSL Service Revenue **

Cable Modem Service Revenue
Cable TV Service Revenue
Wireless Internet Service Revenue
Customer Premises Equipment (CPE) Leasing Revenue
Any Other Internet/Data/Phone/TV Service Revenue

**xDSL Revenue will only be included in this category for those entities who do not choose to participate in the NECA tariff for this service. Those entities who offer xDSL at NECA's tariffed rates will account for this revenue under Account 32.5081, End User Revenue, under Network Access Service Revenues.

5081, End User Revenue

Examples of revenues that can be recorded in this account include:
xDSL Service Revenue (If company participates in NECA tariff for this service)

5200, Miscellaneous Revenues

Examples of revenues that can be recorded in this account include:
Fiber Leasing Revenue
Leasing of Local Loops Revenue (CLEC/UNE-P/Resale)
Installation Revenue
Equipment Sales Revenue
Software Sales Revenue
Miscellaneous Sales Revenue
Network Revenue
Mobile Radio Revenue
Educational/Training/Help Desk Revenue
Internet Solutions Revenue (Web Hosting, Email Accounts, Graphic Design, etc.)
Interactive Television (ITV) Revenue
Consulting Services Revenue
Repair Services Revenue
Other Miscellaneous Revenue
Any Other Revenue Source Not Regulated by Other Accounts or Listed in the Other Accounts

6121, Land and building expense

Examples of expenses that can be recorded in this account include:
Tower lease payments if included as a part of a building

6231, Radio systems expense

Examples of expenses that can be recorded in this account include:
Expenses related to transmitters and receivers in the provision of wireless broadband service, both long haul and local transmission.

6411, Poles expense

Examples of expenses that can be recorded in this account include:

Tower lease payments

6540, Access expense

Examples of expenses that can be recorded in this account include:

T-1 access costs

Back haul/transport costs

Video programming expenses

Appendix - Sample Network Diagrams

Example: Interconnect Ring

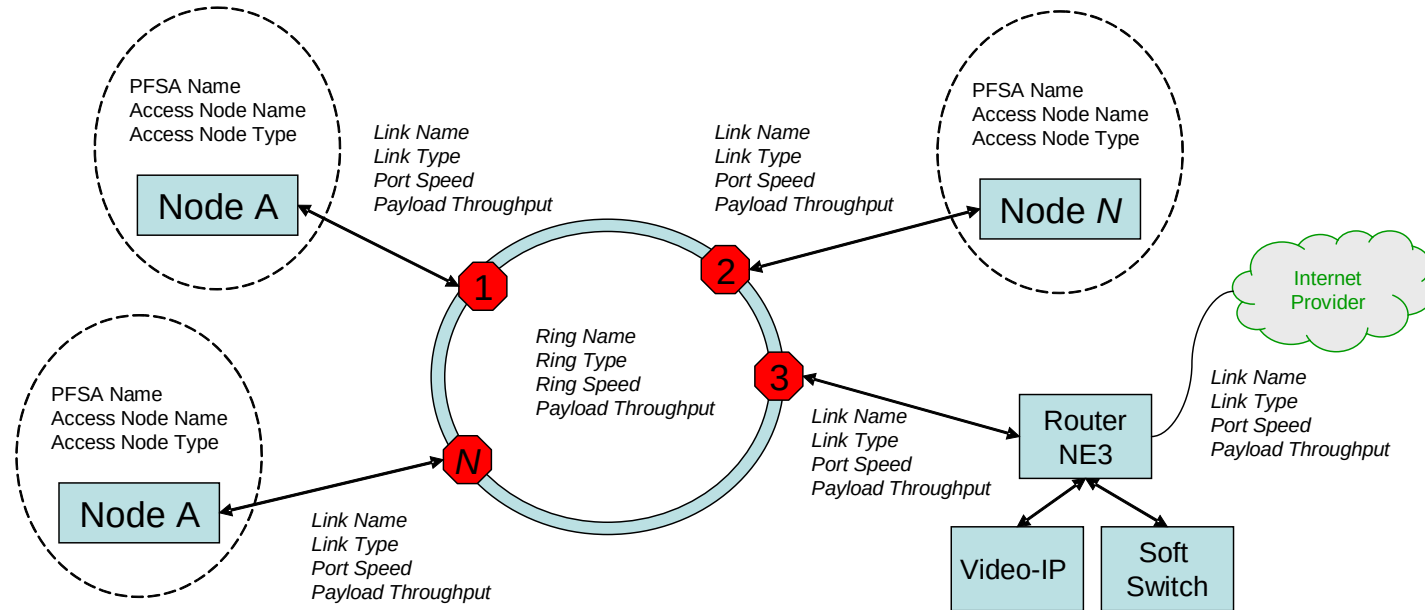

Node Name	Network Element	Service PFSA	Port Speed (Mbps)	Port Payload (Mbps)	Network Element Location (Lat / Long)	Existing or New	Estimated Data / Video / Voice Payloads (Mbps)	Number of PFSA Premises Served

Example: EPON / GPON

Fiber Point-to-Multipoint Access Architecture

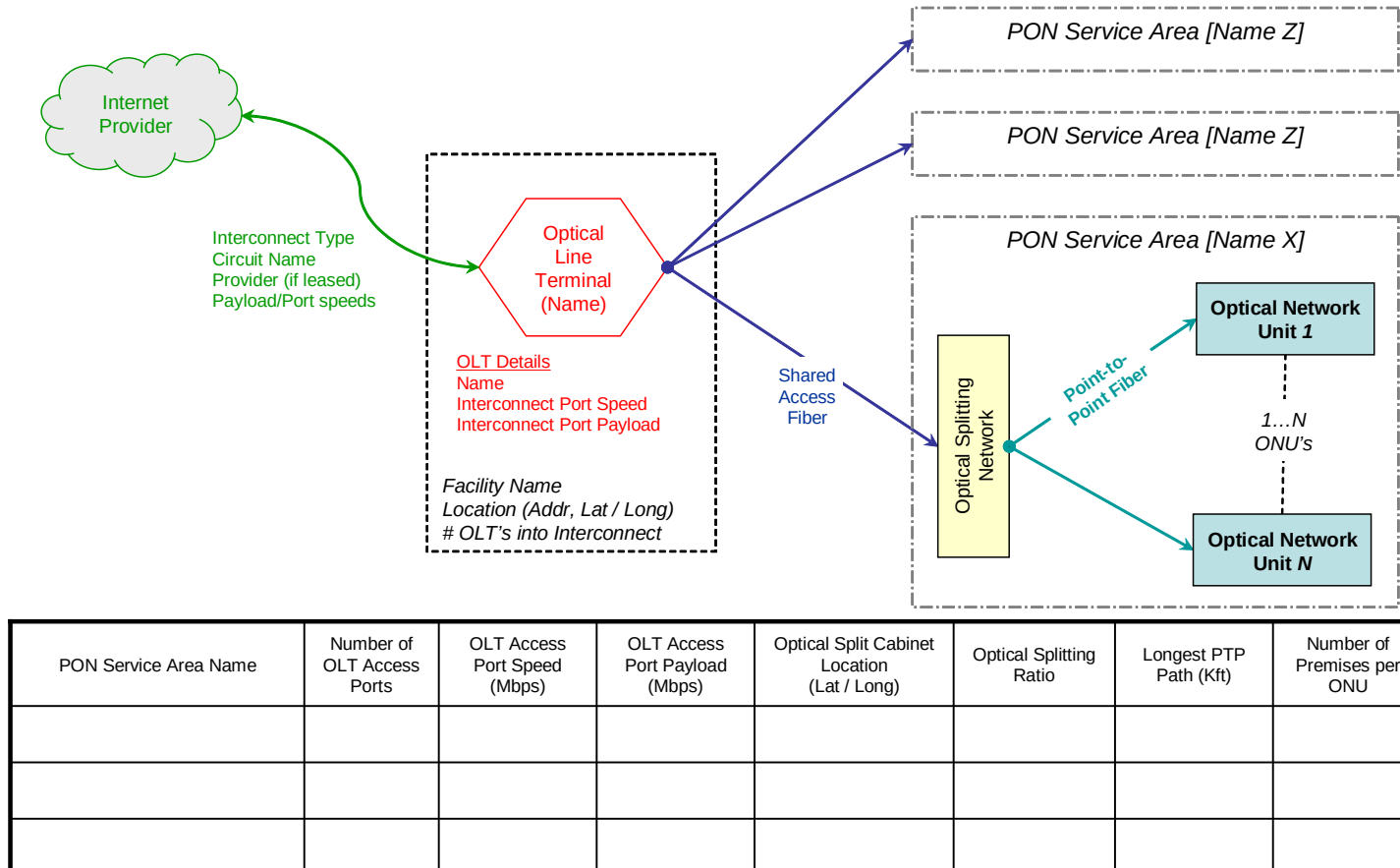

Example: RFoG Access Diagram – Traffic Loading

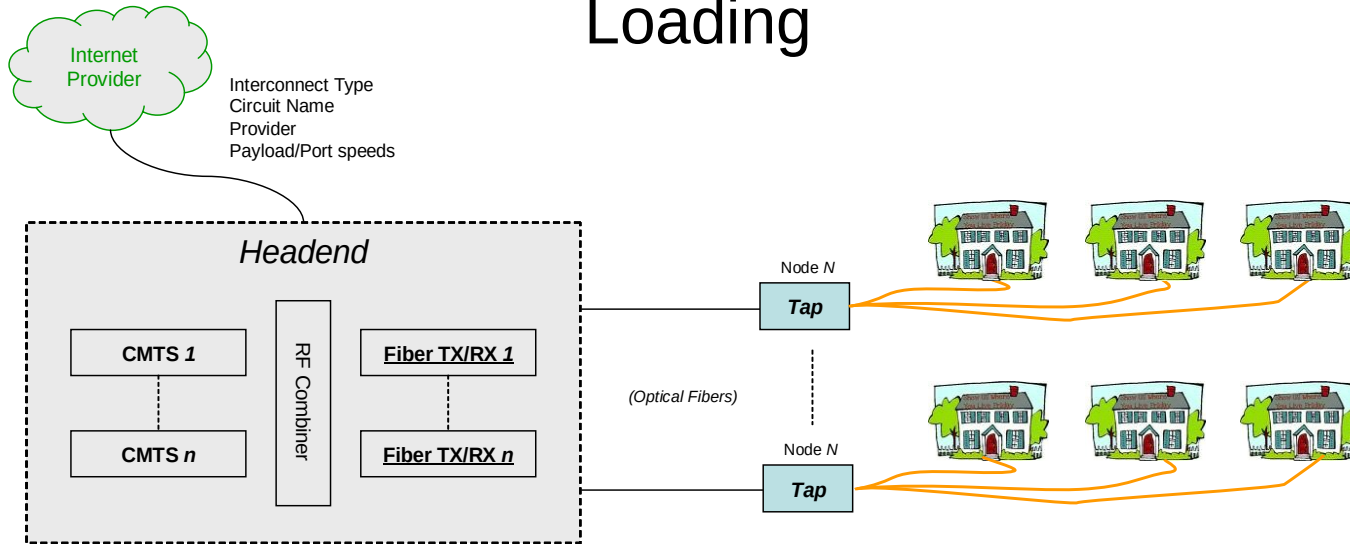

CMTS Name	DOCSIS Technology	Downstream Modulation	Upstream Modulation	Number of Downstream Ports	Number of Upstream ports	Number of Nodes per Downstream Carrier	Homes per Node

Example: RFoG Access Diagram – Outside Plant

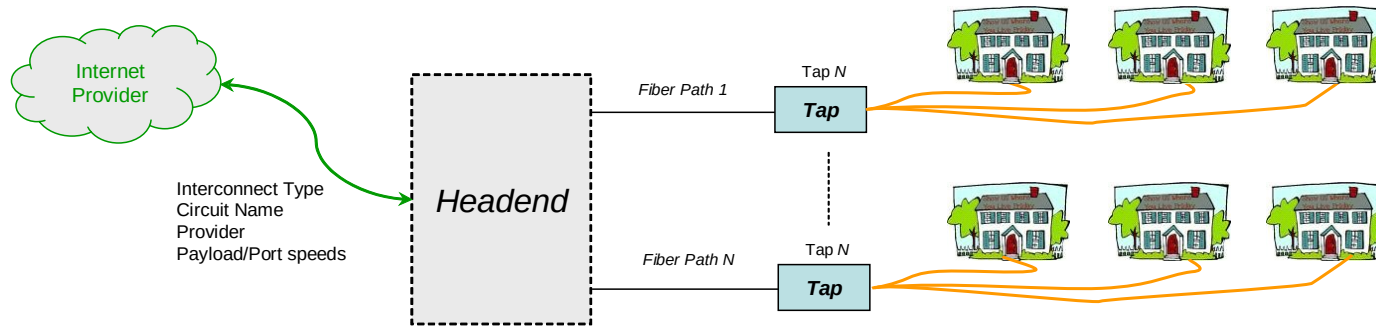

Path Name	Path Length (km)	Node Name	Node Location (Lat/Long)	Average Fiber Drop Length (ft)	Homes per Tap

Example: HFC Access Diagram – Traffic Loading

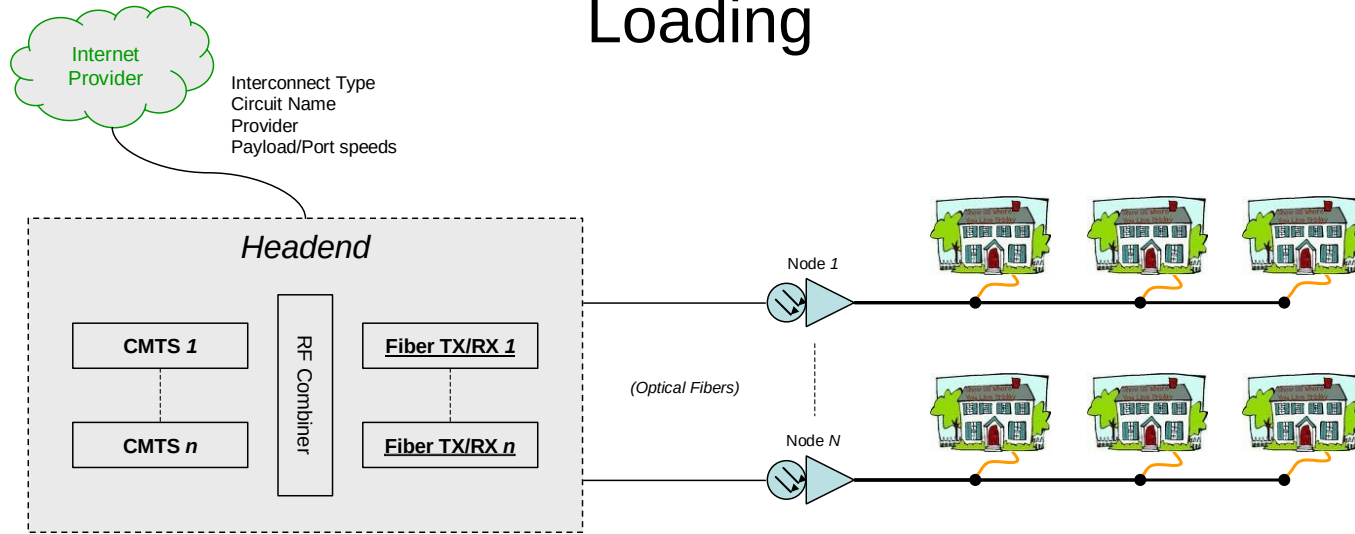

CMTS Name	DOCSIS Technology	Downstream Modulation	Upstream Modulation	Number of Downstream Ports	Number of Upstream ports	Number of Nodes per Downstream Carrier	Homes per Node

Example: HFC Access Diagram – Outside Plant

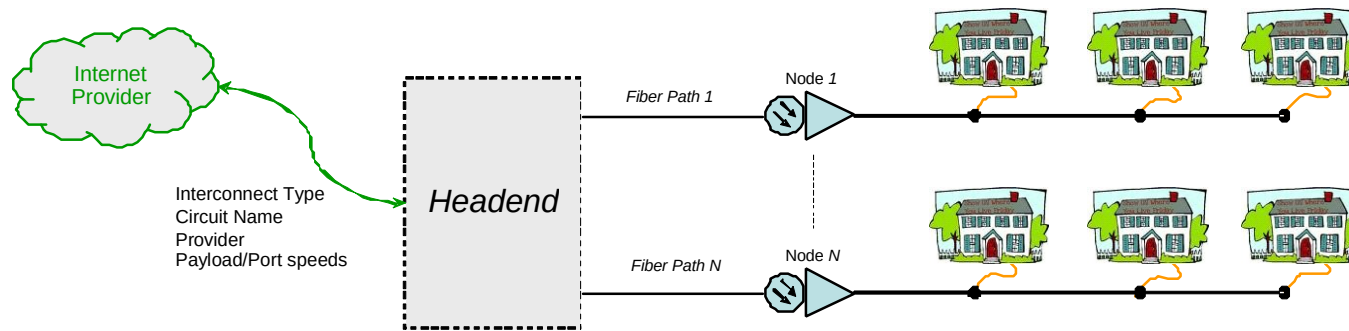

Path Name	Path Length (km)	Node Name	Node Location (Lat/Long)	Coax Cable Distribution Plant miles (this Node)	Average Drop Length (ft)	Homes per Node

Example: Active Ethernet or Fiber Point-to-Point Access Architecture

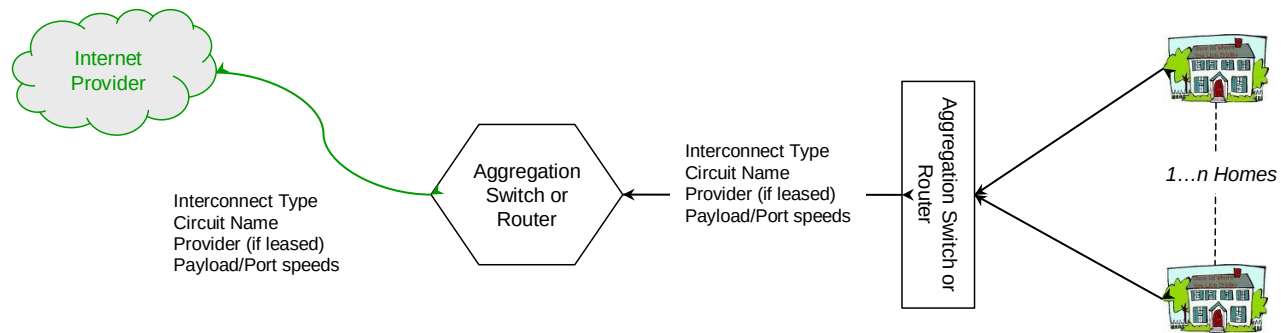

Local Ethernet Aggregation Switch Name	Local Agg Switch location (Lat/Long)	Number of Ports	Port Speed (Mbps)	Shortest Path (Kft)	Longest Path (Kft)	Backhaul Type	Backhaul Speed (Mbps)	Backhaul Link Distance (Kft)

Example: xDSL Access Architecture

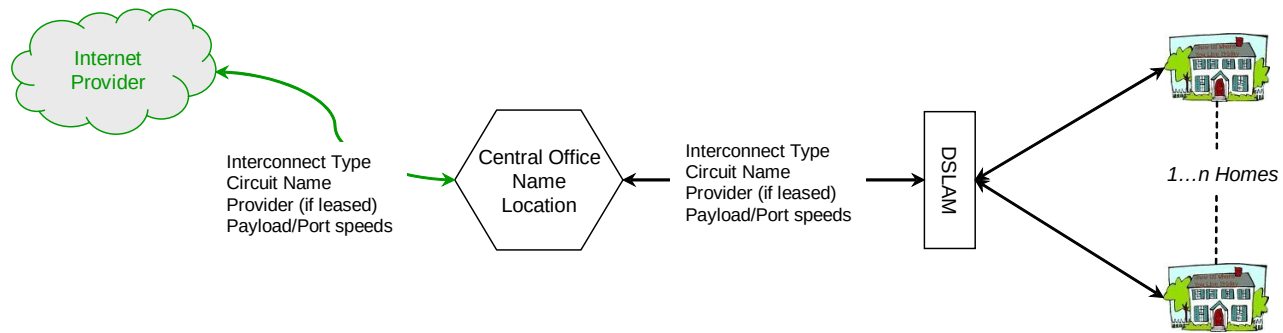

DSLAM Name	DSLAM location (Lat/Long)	DSL Format	Number of DSL Ports	Copper Gauge (AWG)	Shortest Loop (Kft)	Longest Loop (Kft)	Backhaul Type	Backhaul Speed (Mbps)	Backhaul Link Distance (Kft)

Example: Wireless Access Diagram

(Showing Microwave Backhaul and Fiber Backhaul)

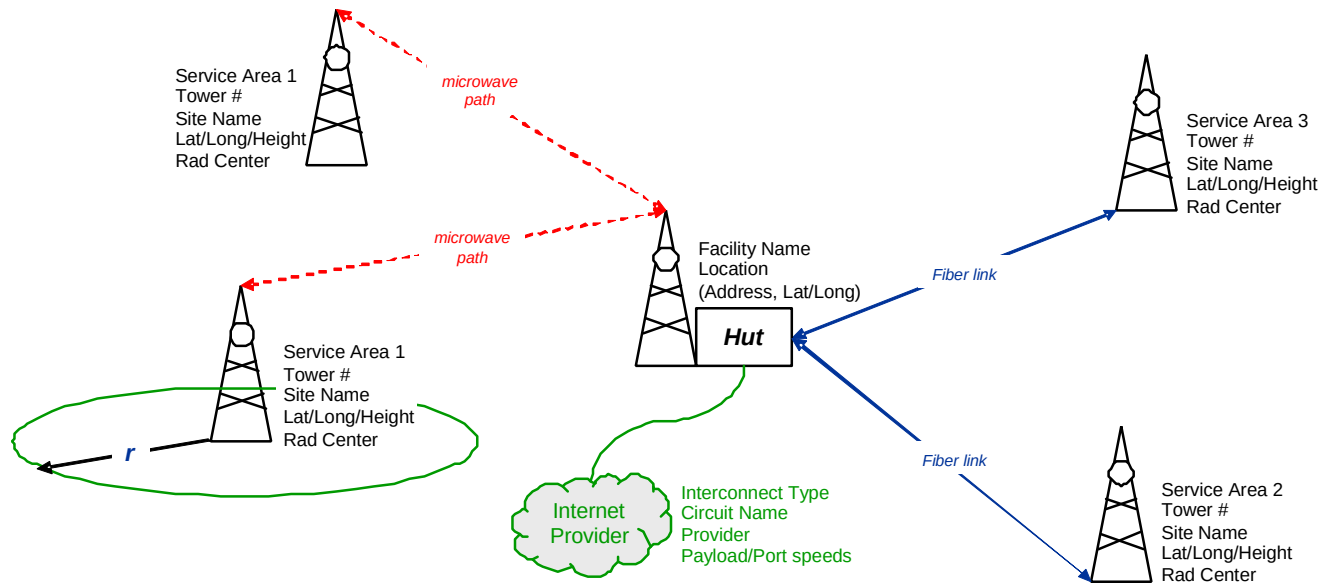

Site Name	Last Mile Coverage Radius (mi)	Number of Last Mile Sectors	Last Mile Frequency (MHz)	Last Mile ACM?	Last mile Bandwidth (MHz)	Backhaul- Leased (provider) or Owned	Backhaul Type	Backhaul Payload (Mbps)	Backhaul Link Distance	Backhaul Frequency (MHz)	Backhaul Bandwidth (MHz)

Example: Wireless Access Diagram

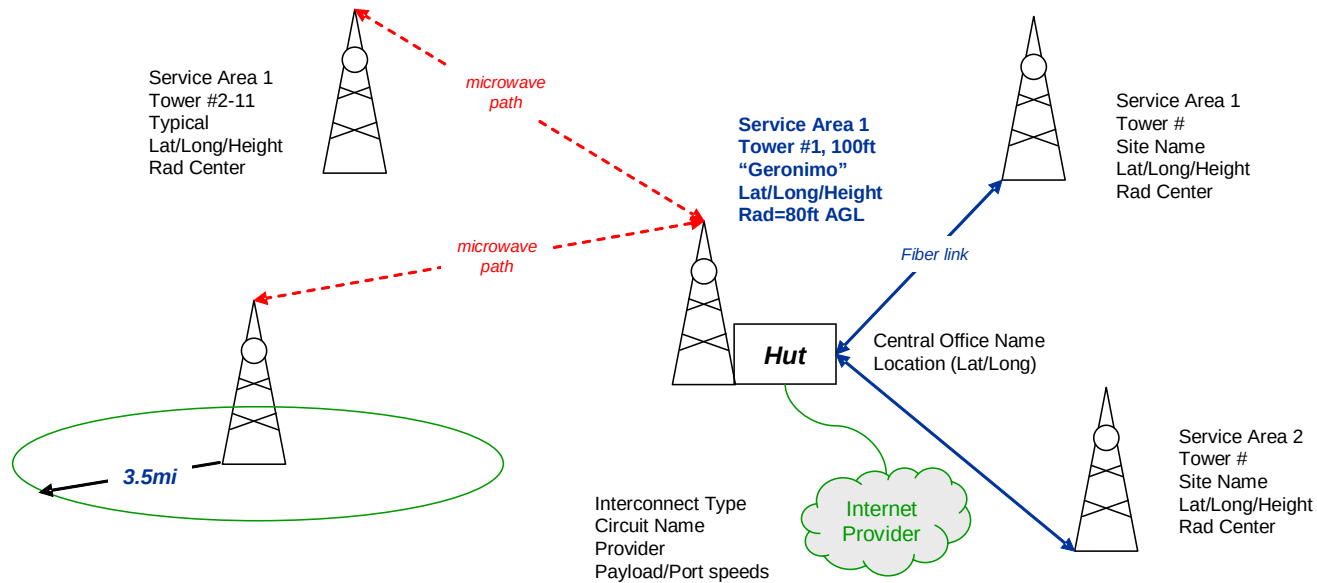

Site Name	Last Mile Coverage Radius (mi)	Number of Last Mile Sectors	Last Mile Frequency (MHz)	Last Mile ACM?	Last mile Bandwidth (MHz)	Backhaul - Leased (provider) or Owned	Backhaul Type	Backhaul Payload (Mbps)	Backhaul Link Distance	Backhaul Frequency (MHz)	Backhaul Bandwidth (MHz)
10X Typical	3.5mi	3	2300MHz	No	5MHz	Leased	Fiber (existing)	20Mbps	30mi	n/a	n/a
"Geronimo"	5.5mi	3	3650MHz	Yes	10MHz	Owned	Microwave	27Mbps	15mi	5800MHz	20MHz