

"Template for Submittal and Evaluation of Ground Control Plans (Submitted for Compliance with 30 CFR 77.1000 and 77.1000-1) MSHA DISTRICT 2

1. Company name & address:

2. Telephone number: _____ - _____ - _____

Fax number: _____ - _____ - _____

Email address: _____

3. (a) Mine name _____

(b) Legal identification number ID _____

(c) County _____ State _____

(d) Pit Number(s) _____ Location _____

4. Officer in charge of health and safety

(Name) (Title)

5. (a) Typical columnar section (Strata Profile) of the strata including the coal seam(s) to be mined.

(1a) Include a copy of drill log data (ex: core recovery to characterize overburden, strike and dip of strata, rock mass classification (Rock Quality Designation (RQD)), groundwater elevation)

(b) List coal seam(s) to be mined and seam thickness.

Name _____ Thickness _____

6. List of each piece of equipment used in pits, on highwalls, and spoil banks, including highwall drills used on the mine site.

Serial Number	Manufacturer	Model	Use
_____	_____	_____	_____
_____	_____	_____	_____
_____	_____	_____	_____

Use additional pages as needed:

7. (a) Method(s) of mining in use at the mine:

(Methods include but are not limited to: dragline, shovel spreads, loader spreads, auger, and highwall miner.)

-
- (b) Indicate whether the method of mining is used for contour, mountaintop, open pit, auger-pit, highwall mining pit, underground faceup, or other types of mining.
-

(c) Drawings and/or map profiles showing sequence of mining in relation to seam locations and methods of mining

(d) When removing coal from the seam, Equipment shall work perpendicular to the highwall no less than the (W) the calculated distance from the highwall referenced from TABLE 3.

8. Attach an engineered drawing(s) showing a profile(s) of the mining sequence for each method of mining to be used that is listed under item No. 7.

9. Attach drawing(s) and include the following pit and highwall information:

(a) Slope of ground to be mined_____

(b) Maximum highwall height_____

(c) Highwall slope_____

(d) Width of highwall benches_____

(e) Spacing of highwall benches_____

(f) Minimum pit width _____

(g) Maximum height of deposited spoil_____

(h) Maximum angle of deposited spoil_____

(i) Description of methods and equipment used to scale and maintain highwall: _____

(Refer to sketches 9(a), 9(b), 9(c) concerning the information mentioned above.)

Pit and Highwall Information

- A. Slope of ground to be mined _____.
- B. Maximum highwall height _____.
- C. Highwall slope _____ degrees.
- D. Width of highwall benches _____.
- E. Spacing of benches for safe control of the highwall _____.
- F. Minimum pit width _____.
- G. Maximum height of deposited spoil _____.
- H. Maximum angle of deposited spoil _____.
- I. Name of coal seam to be mined _____.
- J. Description of methods and equipment used to scale and maintain highwall _____.

SKETCH 9(a)

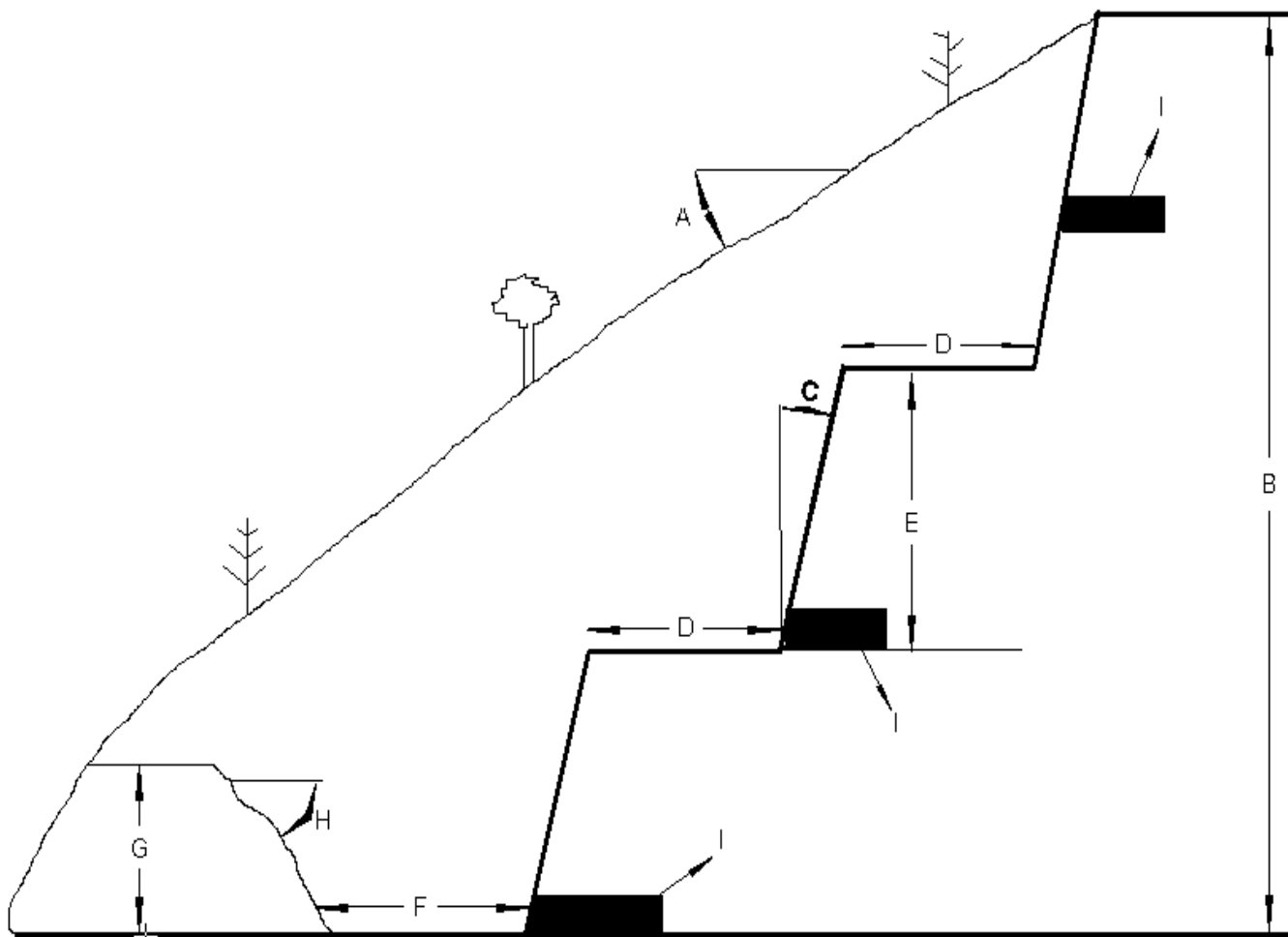

NOT TO SCALE

Pit and Highwall Information

- A. Slope of ground to be mined _____.
- B. Maximum highwall height _____.
- C. Highwall slope _____ degrees.
- D. Width of highwall benches _____.
- E. Spacing of benches for safe control of the highwall _____.
- F. Minimum pit width _____.
- G. Maximum height of deposited spoil _____.
- H. Maximum angle of deposited spoil _____.
- I. Name of coal seam to be mined _____.
- J. Description of methods and equipment used to scale and maintain highwall _____.

SKETCH 9(b)

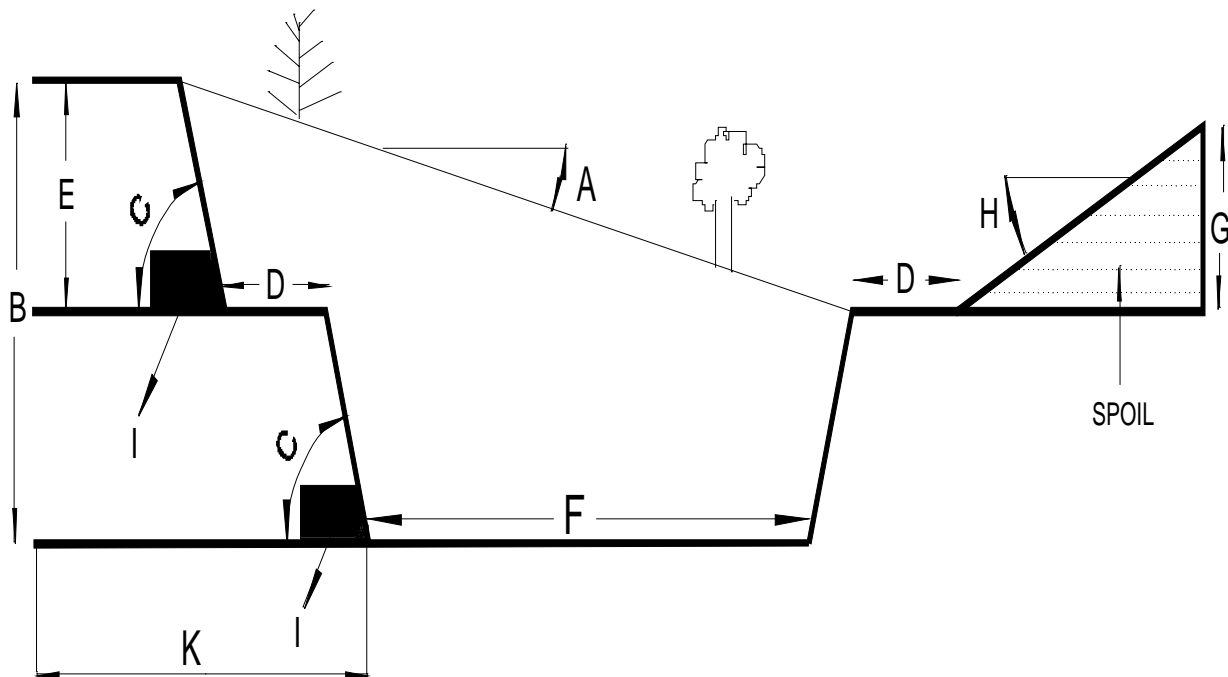

NOT TO SCALE

Pit and Highwall Information

- A. Slope of ground to be mined _____.
- B. Maximum highwall height _____.
- C. Highwall slope _____ degrees.
- D. Width of highwall benches _____.
- E. Spacing of benches for safe control of the highwall _____.
- F. Minimum pit width _____.
- G. Maximum height of deposited spoil _____.
- H. Maximum angle of deposited spoil _____.
- I. Name of coal seam to be mined _____.
- J. Description of methods and equipment used to scale and maintain highwall _____.

SKETCH 9(c)

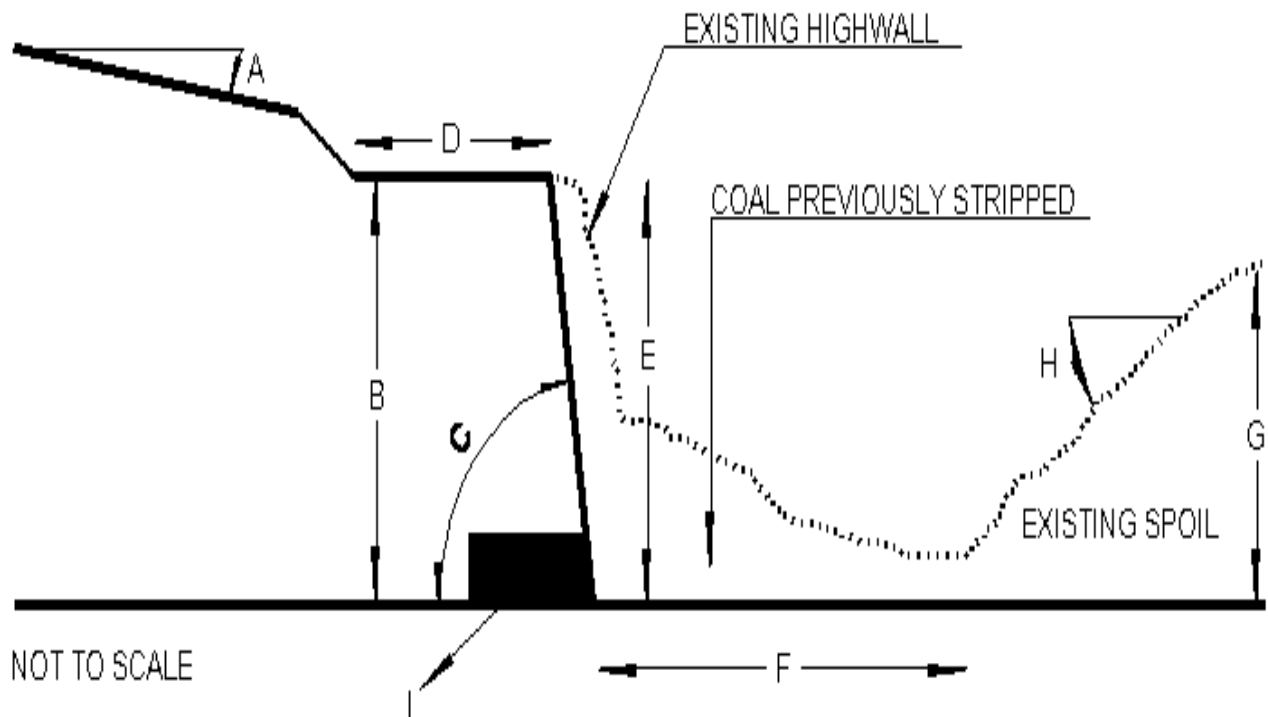

10. Topographic maps showing location of pits (longitude and latitude) and area of proposed mining.
11. Maps with a legend of symbols used and containing the following information:
- (a) Showing the location of any oil or gas wells, high voltage transmission lines with known capacity, gas transmission lines, etc. If none of these structures are on the property, a statement to indicate there are none.

(1a) Gas wells and lines – IF NONE, include statement that no mining, excavation, or equipment/vehicle operation will occur within 150 feet of gas wells or lines.

OR

Include precautions to be taken if any type of work, travel, excavation, or blasting will occur within 150 feet of active gas wells or lines.

Precautions needed for working or traveling near gas lines and/or wells:

Before performing any type of work, travel, excavation, or blasting within 150 feet of active gas lines or wells existing where highwalls, spoil banks, or pits will be developed the following stipulations will be met:

- Any gas line will be considered as being active unless the line has been cut, purged, and capped on each end. Any gas well will be considered active unless the well has been adequately plugged below the elevation of the work area. Documentation will be provided to show that the condition of the gas lines and/or wells is as described.
- Notify the gas company or other entity owning the lines or wells and have them locate and mark the lines or wells according to their operating procedures.
- A pipe line locator of the type used by gas companies (there are different manufacturers) will be used to locate metal gas lines.
- Older plastic lines will be located by survey records if they exist. Recent plastic line installations may have a tracer wire buried with them
- The location of all gas lines will be marked in a distinct color on a certified map with legend identifying color and the map provided with the ground control plan.
- After gas lines are located they will be identified with markers.
- The markers will be no less than 36 inches in height above the ground level and will be identified with a distinct, consistent, reflective marking at the top of the marker.

- The markers will be placed perpendicular (upright) to the location of the gas line, 5 feet from the location of the gas line, and on both sides of the gas line at each marker location.
- The markers will be spaced at no more than 75 feet intervals along the gas line and have a guaranteed line of sight between markers.
- The markers will be made of a weather resistant material.
- The markers will be visible to persons on foot or in equipment from outside the defined zone. The defined zone is the area on both sides of and within 50 feet of the gas line.
- When there is a curve in a gas line, additional markers will be installed 5 feet from each side of the gas line and directly across from each other at any location where any part of a gas line is located more than 5 feet from a straight line extending along the gas line between the center of the gas line at one marked location and the center of the gas line at the next adjacent marked location.
- In areas where equipment/vehicles cross gas lines, the gas line will be encased with a steel pipe (conductor) of a minimum wall thickness of ¼ inch or protected from damage by equivalent means and will be buried a minimum depth of 6 feet where equipment weighing more than 150,000 lbs. cross the lines and will be buried a minimum depth of 3 feet where equipment weighing less than 150,000 lbs. cross the lines. Pickup trucks, six wheel mechanic trucks, and track mounted equipment weighing less than 30,000 lbs. will be allowed to cross low pressure gas lines in areas outside the encased zones only if the depth of the gas line is known to be at least 3 feet and the ground surface is not disturbed.
- In all areas where equipment/vehicles are allowed to cross, the gas lines will be marked by signs designating the crossing area and identifying the presence of the gas line.
- In areas where tree cutting and/or clearing operations is to be performed the markers will be inspected after the operation is completed and any markers found to be missing or damaged will be replaced as needed.
- When tree removal activities must be conducted within 50 feet of the gas line, a grapple type excavator will be used to pick the fallen trees from the marked area. This work can not be conducted unless the gas line is buried more than two feet below the surface of the ground and at no time can the ground be disturbed below the surface.
- At no time will mining, excavation, or equipment/vehicle operation occur within 50 feet of a gas line or well except that equipment/vehicles will be allowed to cross at designated crossings. Markers will be established around gas wells to identify this 50 ft. zone.

(b) Showing underground mine workings within the proposed mining area. Listing the coal seam in which the workings are located. If none, a statement to indicate there are none.

Note

Include plans for highwall development directly over any previous underground mined areas (including highwall and auger mining). Plans must include precautions taken to insure highwall stability and safe working conditions.

Because highwall failure would not be expected to occur above the area of pressure arch formation in the highwall where second mining has not occurred limiting exposure to within 30 feet of the toe of such a highwall would be expected to provide for safe working conditions as long as stress cracks or stability failure did not occur in the highwall at any location more than 40 feet above the toe of the highwall.

Because extensive highwall failure would be expected to occur directly above areas that have been second mined, highwall mined (due to low stability parameters of near 1.3 and alignment issues), and in cases of low stability where auger mining has occurred, plans for highwall development directly over these areas need to include **immediate wall bench spacing not to exceed 40 feet** measured from the pit floor and **limiting exposure of persons to the highwall. The bench width would need to be a minimum of 30 feet.** This provides abutment and removes weight from above the immediate highwall for increased stability. **Decreasing the immediate highwall spacing below 30 feet would reduce the abutment effect on stability of any highwall existing above the bench.** Persons should be kept away from the toe of the highwall for a distance equal to that bench spacing. Other no less effective means can be used in lieu.

12. A statement that if underground mine workings are encountered during surface mining operations; the examination required by 30 CFR 77.1713 shall include tests for methane and oxygen deficiency in the pit areas by a qualified person. The results of these examinations shall be recorded along with the record keeping required by the regulations. Methane and oxygen detectors shall be kept on the job site in the pit during mining operations, maintained in permissible conditions, and shall be calibrated at least once every 31 days using manufacturer's test apparatus. The results of these tests shall be recorded in a book kept at the mine office. And MSHA will be notified during the shift.
13. A Statement that if mining exposes abandoned underground mine openings, these mine openings shall be blocked to prevent entering by the end of the shift.

(d) Previous mining same seam, above, & below – IF NONE, include statement that highwall will not be developed directly above or directly adjacent to any previously underground mined areas (including highwall and auger mining).

OR

If stress cracks exist or stability failure occurs in any portion of the highwall, where the highwall is developed directly above or directly adjacent to any previous underground mined areas (including highwall and auger mining), operations in the affected area will be immediately stopped, the affected area will be barricaded, and this plan will be immediately revised. The

revision will identify the reason for revising the plan to alert MSHA to the conditions. Persons will not work or travel within 30 feet of the toe of highwalls developed directly above or directly adjacent to any previous underground mined areas (including highwall and auger mining). This includes persons on foot and persons operating equipment.

14. A sketch showing the requirements of the local electrical power company concerning the amount of material to be left in place when mining near poles supporting power transmission lines.

Example: WHEN ELECTRIC LINES ARE ENCOUNTERED BY THE OPERATOR THE COMPANY WILL FOLLOW THE FOLLOWING SKETCHES.

Sketch #14(a):

Electric Pole (Single)

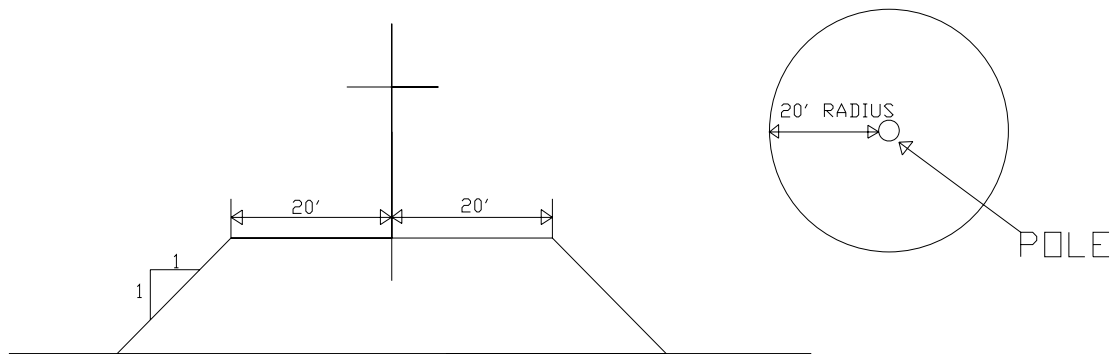
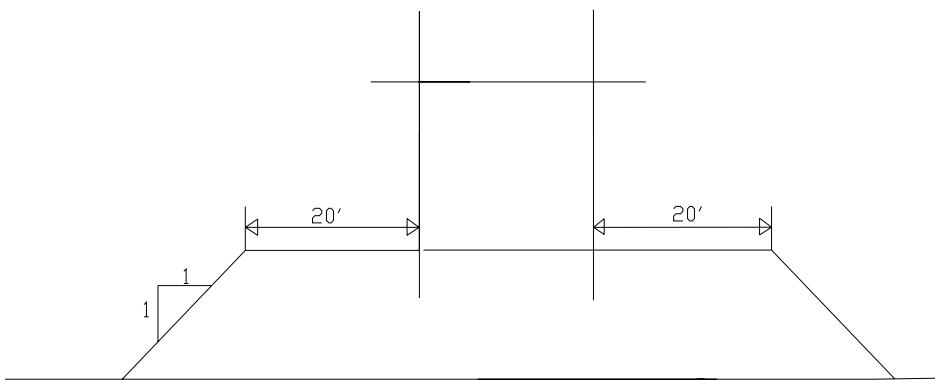
**Sketch #14(b):**Electric Pole
(Double)

15. A statement concerning the method of controlling water seepage from rainfall or the natural watershed from eroding at the highwall or spoil banks.
16. A statement that all loose materials shall be stripped and/or kept a safe distance from the top of the pit or highwall.

(a) What procedures are followed to assure that workers who perform assigned duties near highwalls are not exposed to unsafe conditions?

If the method of mining includes working persons near highwalls, show in the plan with drawings or by statements how the method of mining ensures that the recommendations outlined in Item 6 (Working Near Highwalls) of the attached guidelines are incorporated.

Notes on small area or individual rock fall (continued):

30 CFR 77.403 requires Falling Object Protective Structures (FOPS) when necessary to protect mobile equipment operators. The FOPS must comply with Society of Automotive Engineers (SAE) Standard J231, a testing procedure to establish the minimum structural strength of a FOPS. In this test, a 500-pound steel cylinder is dropped from 17 feet to create an impact force (kinetic energy level) of 8,500 ft-lb. From Table 1, this energy is approximately equivalent to a 160-pound rock falling about 50 feet. If equipment with only a standard FOPS structure is working directly beneath a highwall in a zone that could be impacted by falling rock, the FOPS standard could be exceeded with a rock if the wall height is more than 50 feet. Rocks falling from much shorter distances can cause significant damage if the rock strikes the equipment in a vulnerable location such as the windshield. The table shows that small rocks falling short distances can generate large impact forces.

Rock catchments, either benches or catch areas behind berms, can be used to control the falling rock. Berms serve a second function by keeping personnel out of potential impact zones. Research has been conducted and guidelines have been developed originally by Ritchie, A.M. (1963) "The evaluation of rock fall and its control," Stability of Rock Slopes, Highway Research RECORD #17, and more recently by the Oregon Department of Transportation and Federal Highway Administration (2001), "Rockfall Catchment Area Design Guide." These researchers conducted tests to determine the falling rock impact zones, runout distances, and berm parameters. Table 2 provides a summary of the results from the Oregon study and Table 3 from the Ritchie study.

TABLE 2

Slope Height (ft)	Slope (Angle)	Impact Distance from Toe of Slope on Flat Ground (ft)	Roll Out Distance from Toe of Slope On Flat Ground (ft)
40	Vertical (90°)	14	30
	0.50H:1V (63°)	6	48
	1.0H:1.0V (45°)	0 (no freefall)	60
60	Vertical (90°)	16	30
	0.50H:1V (63°)	15	66
	1.0H:1.0V (45°)	8	67
80	Vertical (90°)	21	30
	0.50H:1V (63°)	19	68
	1.0H:1.0V (45°)	10	80

Table based on 99% retention of generally spherical, intact blocks of rock with an average diameter of 1 to 3 feet.

(continued)

Notes on small area or individual rock fall
(continued):

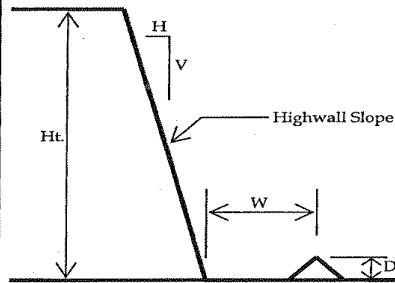

TABLE 3

Highwall Slope	Ht.	W	D
Near Vertical	15-30	10	3
Near Vertical	30-60	15	4
Near Vertical	over 60	20	4
0.25H to 0.3H:1V	15-30	10	3
0.25H to 0.3H:1V	30-60	15	4
0.25H to 0.3H:1V	60-100	20	6
0.25H to 0.3H:1V	over 100	25	6
0.5H:1V	15-30	10	4
0.5H:1V	30-60	15	6
0.5H:1V	60-100	20	6
0.5H:1V	over 100	25	8
0.75H:1V	15-30	10	3
0.75H:1V	30-60	15	4
0.75H:1V	over 60	15	6

The berm height (D) and distance from the highwall (W) are based on rocks falling, bouncing, or rolling off of a face. A large number of full scale tests where rocks were dropped off of highwalls of various heights and configurations were used in the derivation of the dimensions in Table 3. As the slope angle flattens, there becomes a point where the berm may need to be directly against the toe. This positioning helps ensure the rock rolling down the slope impacts the berm at a right angle and the rock won't just roll over the berm.

The type of material at the base between the berm and the highwall has a significant effect on the motion of a rock after it strikes the ground. A layer of soft material at the base of the wall tends to absorb energy from the falling rock and thus may allow for narrower widths and lower berms. When combined with a rock catching berm, placing a flat, loose, or soft layer of material at the base of a highwall will further reduce exposure by reducing the amount of rock rolling/bouncing into the pit. However, when fallen material has accumulated too high or if there are large rocks near the base of the highwall, additional falling rocks may be deflected farther out than if the area at the base of the highwall were clean. Similarly, piling material against the base of the highwall can cause falling rock to be deflected further from the highwall where it may enter a work area. The dimensions shown in Tables 2 and 3 will be affected due to the presence of material at the base of the highwall.

(continued)

(b) Before persons on foot work near the highwall a competent person will make an examination of the highwall immediately before working near the wall and will have any unsafe conditions corrected before exposure occurs. Persons traveling on foot in close proximity to a highwall must have a spotter stationed to watch the highwall.

(c) The cabs of track mounted equipment with side mounted cabs such as drills and excavators will be located away from the highwall at all times so as to never position the cab between the boom or drill mast of the machine and the highwall when the machine is working near the toe of the highwall unless it can be shown that failure of the highwall will not affect the operator. If it is necessary to drill the first two or three holes of a pattern with the drill angled toward the wall, an examination of the highwall will be made by a competent person immediately before drilling the first holes of the pattern near the

highwall and any hazards found will be corrected before work is done. All other holes will be drilled with the cab away from the highwall.

(d) A buffer, berm, or other no less effective means will be provided at the toe of live stacked spoil piles (includes back stack, dumped in place, and dragline spoils) where roadways and/or work areas exist that is of adequate design and dimension to keep material from rolling/sliding off the pile into the work areas and roadways.

OR

No person will work or travel near the toe of live stacked spoil piles where a buffer, berm or other no less effective means to keep material from rolling or sliding off the pile into the work area(s) and roadway(s) has not been provided.

(e) When failure to control the developing highwall occurs such as the existence of overhangs, loose material, unconsolidated rocks, material falling into the pit, movement in the wall, or blasting practices fail to result in a clean and stable highwall, and corrective action can not be taken to eliminate the existence of these conditions, the affected area will be barricaded to prevent persons from being exposed to the conditions and the plan will be revised to safely control the highwall and provide for safe conditions.

17. Blasting plan showing drill hole spacing, typical loaded drill hole, and sequence of drill hole detonation.
18. A statement concerning the distance the haulage ways will be maintained from the highwall.

SKETCH #18

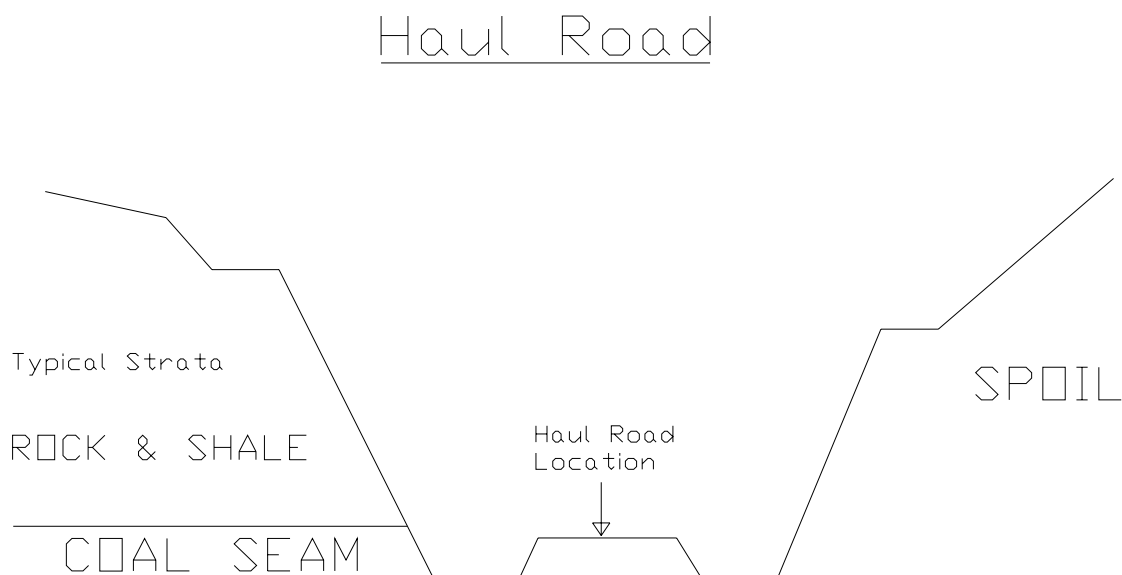

19. A statement addressing truck dump points being maintained on the grade that the rear of the truck will be higher than the front of the truck.

(a) End Dump Valley Fill Information

NOTE: THESE PRECAUTIONS ALSO APPLY TO BACKSTACK FILL

If the method of mining includes end dumping to establish a valley fill, attach an additional engineered drawing showing how the method of mining ensures that all the recommendations outlined in Item 7 (End Dump Valley Fills) of the attached guidelines are incorporated. This drawing would show the following information:

Note: Refer to Item 7 in the guidelines and sketch # 19 below to determine the following information:

- a. The established angle of the outer slope of the fill. (see item 1 in sketch 19)
- b. The maximum height spoil will be deposited in the fill. (see item 2 in sketch 19)
- c. The location and height of the berm used to prevent overtravel and overturning at or near the edge of the fill where equipment dumps. (see item 3 in sketch 19)
- d. The distance short dumping will occur back from the edge of the fill should the slope become steeper than the established angle of repose. (see item 4 in sketch 19)
- e. The distance short dumping will occur back from any tension crack that would occur in the fill. (see item 5 in sketch 19)
- f. Examination methods used on the fill.

- g. A typical projected depth and orientation in the fill of any lift to be cut by a dozer should tension cracks exist in the fill. (see item 6 in sketch 19)

Include a statement in the drawing to the effect that:

- (1) Any such cut will begin a safe distance back from the tension crack to the specified depth (such as the depth of the dozer blade's height) and extend to the outer edge of the fill.
 - (2) The desired depth of the cut will be obtained by beginning at the back of the cut and taking small horizontal lifts that cause the blade to fill near the end of the cut where that material is deposited at the edge of the fill. That material is bumped over by the next push.
 - (3) The short dumped loads would then be pushed to fill this cut before dumping at the edge would occur, and should another tension crack occur, the process would be repeated.
- h. A statement in the drawing dictating the means used to prevent water from impounding near the outer edge of the fill.

Sketch #19

20. Pages of the plan and drawings are to be numbered.

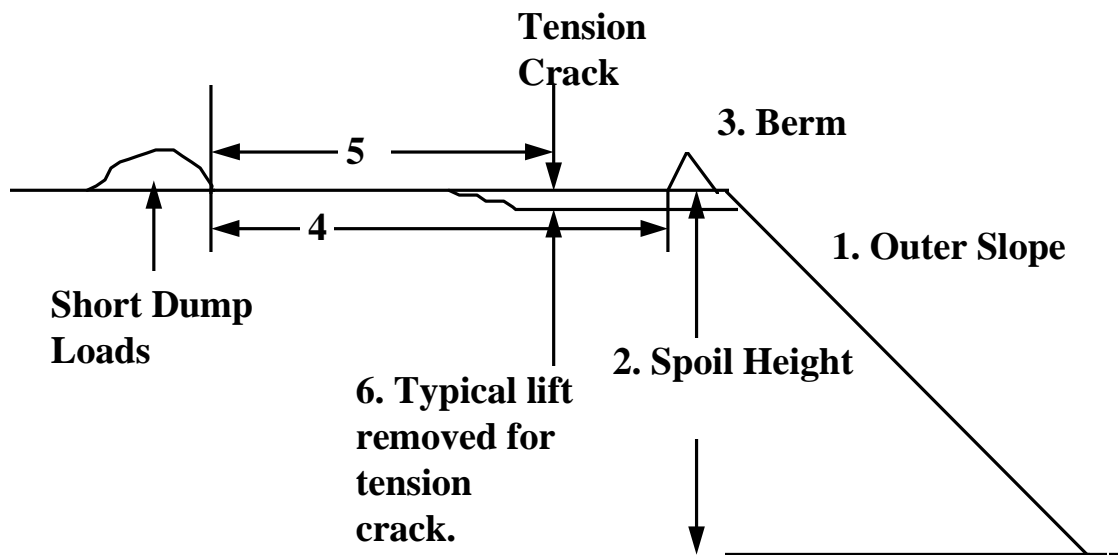

21. Mine company official responsible for implementation of the plan. _____
Date _____

Note: Additional information may be needed depending upon the highwall, strata, slope, type of mining, etc.

U.S. Department of Labor

Mine Safety and Health
Administration
1100 Wilson Boulevard
Arlington, Virginia 22209-3939



ISSUE DATE: July 13, 2010

PROGRAM INFORMATION BULLETIN NO. P10-09

FROM: KEVIN G. STRICKLIN **Charles Thomas for**
Administrator for
Coal Mine Safety and Health

NEAL H. MERRIFIELD *Neal H Merrifield*
Acting Administrator for
Metal/Nonmetal Mine Safety and Health

LINDA F. ZEILER **John Faini for**
Acting Director of Technical Support

SUBJECT: Safety Precautions for Operating Rubber Tired and Track-Mounted Excavators

Who needs this information?

This Program Information Bulletin (PIB) applies to surface coal and metal and nonmetal mine operators, contractors, equipment manufacturers, miners, miners' representatives, and Coal and Metal and Nonmetal Mine Safety and Health enforcement personnel.

What is the purpose of this PIB?

This PIB alerts the mining industry and MSHA enforcement personnel of hazards related to operation of rubber-tired and track-mounted excavators used at surface coal and metal and nonmetal mines. Improper operation, inadequate equipment protection and operator training procedures can result in serious injuries or fatalities.

Information

Excavators expose miners to hazards similar to those presented by front end loaders, including rollover of the equipment and being struck by objects falling onto the equipment. To decrease the risk of injury when operating excavators, mine operators must make certain that appropriate machines are selected and used for the intended work applications, excavator operators are appropriately trained and wear seat belts, and examinations of the work area are conducted before and during the operation of the excavator. A thorough workplace examination includes checking highwalls for loose material, overhangs, clay seams, strata slips and dislocations, and old mine openings. An examination is intended to detect unsafe conditions so that corrective action can be taken prior to work beginning, and appropriate precautions can be taken during operation.

MSHA is particularly concerned with preventing excavator accidents by implementing proper protective measures. When excavators clear highwall benches, an equipment rollover hazard may exist if the excavator is operated near the edge of the bench. The outside edge of an excavator's track should be positioned no closer to the edge of the consolidated bench surface than half the overall width of the machine. In many cases, a bench width of at least 25 feet should be sufficient to provide safe maneuverability of the equipment; however, an examination of the work area is necessary to determine if this width is sufficient.

Excavators frequently perform work that creates uneven or unconsolidated ground on elevated slopes, increasing the risk of equipment overturning. Therefore, MSHA recommends that excavators operated in elevated positions be equipped with certified roll over protection structures (ROPS), or that mine operators use dozers or other equipment that provides a higher level of protection for miners performing the work.

Excavators should also be equipped with adequate falling object protective structures (FOPS) to protect operators from material falling onto the equipment. The FOPS will reduce accidents such as those involving scaling a highwall where the highwall is at a height above the cab compartment. Mine operators should also consider other measures to protect excavator operators from being struck by material falling from highwalls, such as: (1) equipping excavators with appropriate length booms, dippers, and other related attachments to ensure the excavator and its operator remain as far from the highwall base as possible during scaling operations; and (2) utilizing rock deflectors or similar attachments to protect the excavator operator from falling material.

MSHA recommends that mine operators using excavators in the mining process contact the equipment manufacturer to determine the availability of ROPS and FOPS for retrofitting existing equipment.

In addition, excavator operators must be trained to recognize hazards in the work area, including the adverse effects of the weather and freeze/thaw cycles. The excavator operator at times must not be so attentive to the task of loading material or scaling the highwall, that they become unaware of hazards. Task and refresher training tailored to the prevailing conditions at individual mine sites, and regular observation of, and feedback to, equipment operators will provide the best environment for early detection and correction of operational behavior errors and actions that may place miners at risk.

What is the background for this PIB?

From January 1, 2002, through September 29, 2009, sixteen accidents involving excavators occurred at surface coal mines. Eleven of these accidents were the result of equipment rolling over, while five accidents were the result of objects or material falling or sliding onto the equipment. Two of the sixteen accidents resulted in fatal injuries. In one accident, a miner received fatal crushing injuries when the excavator he was operating rolled over a bench onto its side while cleaning a bench. During the process of repositioning the equipment, the operator misjudged his position and one of the tracks slipped over the edge of the bench.

From January 1, 2002 through September 29, 2009, thirty-four accidents involving excavators occurred at surface metal and nonmetal mines. Seventeen of the accidents were the result of material falling or sliding onto the excavator and twelve of the accidents were the result of equipment rolling or sliding over. Four of the thirty-four accidents resulted in fatalities. One of those fatalities was a result of the ground failing under an excavator working on an embankment, causing it to tip over.

What is MSHA's authority for this PIB?

The Federal Mine Safety and Health Act of 1977, as amended, 30 U.S.C. § 801 et seq.; 30 C.F.R. § 77.1713(a), 30 C.F.R. §§ 56.18002, 30 C.F.R. § 56.3130, 30 C.F.R. § 56.3401, 30 C.F.R. 46.7 and 30 C.F.R. 48.27

Where is this PIB on the Internet?

This information may be viewed on the Internet by accessing MSHA's home page www.msha.gov, then choosing "Compliance Info" and "Program Information Bulletins."

Who are the MSHA contact persons for this PIB?

Coal Mine Safety and Health, Safety Division
Stephen J. Gigliotti, (202) 693-9479
E-mail: gigliotti.stephen@dol.gov

Coal Mine Safety and Health, Safety Division
Charles E. Carpenter, (202) 693-9532
E-mail: carpenter.charles@dol.gov

Metal and Nonmetal Mine Safety and Health
Marvin D. Lichtenfels, (202) 693-9606
Email: lichtenfels.marvin@dol.gov

Technical Support, Approval and Certification Center
James L. Angel, (304) 547-2064
Email: angel.james@dol.gov

Who will receive this PIB?

MSHA Program Policy Manual Holders
Miners' Representatives
Coal and Metal and Nonmetal Mine Operators

Contractors performing work at Coal and Metal and Nonmetal Mines
Equipment Manufacturers Special Interest Groups



Mine Safety and Health Administration

MSHA - Protecting Miners' Safety and Health Since 1978

 Print This Page

[Printer Friendly Version](#)

U.S. Department of Labor

Mine Safety and Health
Administration
1100 Wilson Boulevard
Arlington, Virginia 22209-3939



ISSUE DATE: February 25, 2011

PROGRAM INFORMATION BULLETIN NO. P11-02

FROM: KEVIN G. STRICKLIN
Administrator for
Coal Mine Safety and Health

SUBJECT: -Issue of P09-02 - Filing of Ground Control Plans for Surface Coal Mines

Who needs this information?

Coal mine operators, miners and miners' representatives, and Mine Safety and Health Administration (MSHA) enforcement personnel should have this bulletin.

What is the purpose of this program information bulletin (PIB)?

The purpose of this PIB is to identify the advantages to mine operators of submitting their ground control plans to MSHA well in advance of commencing mining to avoid delays if safety issues are identified with the ground control plans.

Information Under the requirements of 30 C.F.R. § 77.1000, mine operators are to establish and follow ground control plans for "safe control of all highwalls, pits and spoil banks . . . which shall be consistent with prudent engineering design and will insure safe working conditions." Under 30 C.F.R. § 77.1000-1, a mine operator

must file a copy of the ground control plan with the District Manager.

Under certain mining conditions, highwall plans and other ground control plan designs may be inadequate and not in conformance with prudent engineering design parameters. For safety reasons, such as reducing miner hazard exposure and minimizing risks related to highwall mining activity, MSHA must assure the adequacy of all highwall and ground-related plans. If major flaws are identified in the plan after mining commences, MSHA could issue citations or orders for remedial purposes. The consequences of MSHA citations could include additional engineering costs and mining delays, which could be lengthy, and adverse economic results until plans consistent with "prudent engineering design" are prepared and filed with MSHA. In addition, if a ground control plan was not filed with MSHA prior to beginning mining, those mine operators could be subject to a citation as well. In order to avoid such circumstances, MSHA strongly encourages mine operators to involve the Agency very early in the ground control plan design and submittal process. The benefit of this approach would be to obtain MSHA agreement that plans are "consistent with prudent engineering design and will insure safe working conditions" prior to adoption, thereby increasing protection for miners and avoiding delays and adverse economic outcomes.

With this in mind, mine operators should consider the following when designing and submitting ground control plans:

Involve MSHA as early as possible and prior to mining for assurance that design parameters are sound, adhere to prudent engineering practices, and afford the miners ample safety protections.

Develop ground control plans that specify remedial measures for adverse conditions such as those presented by faults, fractures, joints, and/or other geologic anomalies, old underground mines, and potentially adverse weather conditions.

Involve front-line supervisors when developing mining plans and apply prudent engineering principles to address both normal and adverse conditions.

What is the background for this PIB?

On April 17, 2007, two miners were fatally injured when a highwall failed while the miners were operating equipment in the pit bottom between the highwall and backfilled overburden/spoil. The collapse of the highwall released an estimated 44,000 cubic yards of rock and material. Also, on January 12, 2008, a shovel operator, positioned beside his shovel and a highwall, was fatally injured when the highwall collapsed. The highwall consisted of sandy material and was approximately 45 feet high.

Authority

The Federal Mine Safety and Health Act of 1977, as amended, 30 U.S.C. § 801 et seq.; 30 C.F.R. §§ 77.1000 and 77.1000-1.

Internet Availability

This PIB may be viewed on the Internet by accessing MSHA's home page at www.msha.gov then choosing "Compliance Info" and then "Program Information

Bulletin."

Contact Person(s)

Coal Mine Safety and Health
Terry L. Bentley, (202) 693-9521
E-mail: bentley.terry@dol.gov

Distribution

MSHA Program Policy Manual Holders
Miners' Representatives
Coal Mine Operators
Special Interest Groups

