



Investigation Guideline

Product: Window Covering Cords
Appendix # : 136
Revision: October 2008
Update: October 2008

I. Introduction
A. Background

From 1990 to 2007, CPSC received reports of 217 strangulations (approximately 12 deaths annually) involving cords on window blinds. The strangulation victims ranged in age from 7 months to 8 years old. The majority of the strangulations involved the operating cords of horizontal blinds, the inner cords of horizontal blinds, and the operating cords of vertical blinds.

Strangulation occurs when the victim places his or her head in a loop in the cord of the window blind product and becomes fully suspended in a hang as shown in Figure 1 or partially suspended in a hang as shown in Figure 2.



As seen in the above figures, a strangulation hazard exists whenever the window blind cord is configured as a loop. This can occur due to the design of the product (such as continuous cords found on vertical blinds), through manipulation of the product cord (such as loops formed by pulling down on the inner cords of horizontal blinds), or through modification of the product cords by the consumer (such as loops formed by tying separate cords into one knot).

Past investigations have identified the following strangulation scenarios:

1. Victim strangled in a continuous loop, usually the cord or chain of a vertical blind. Continuous loops are also found on some horizontal blinds.

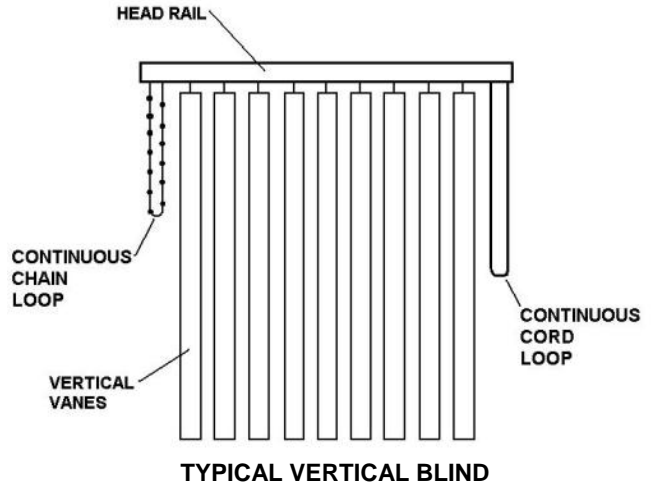
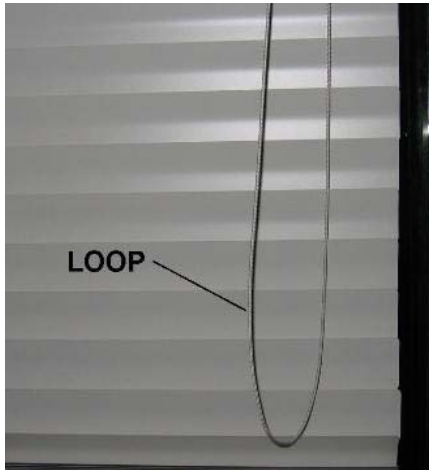

2. Victim strangled in a loop formed by multiple cords terminating in a single tassel. Usually involved the operating cords of a horizontal blind.

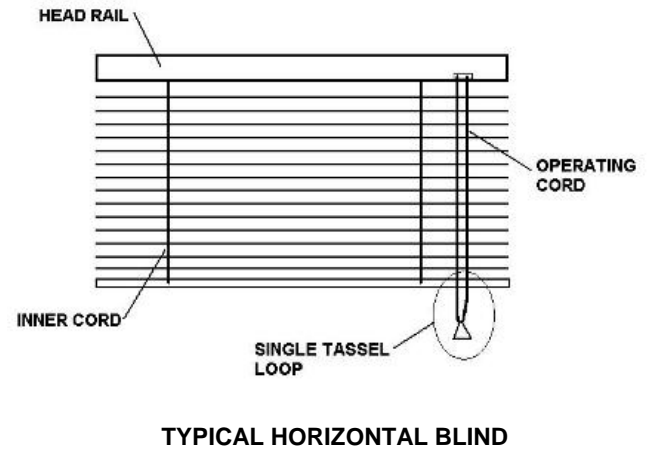

3. Victim strangled in a loop formed by pulling out the inner cord of a horizontal blind.

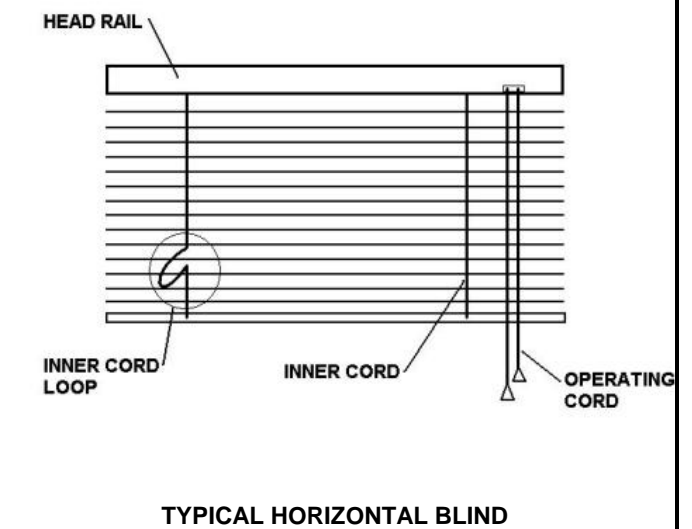
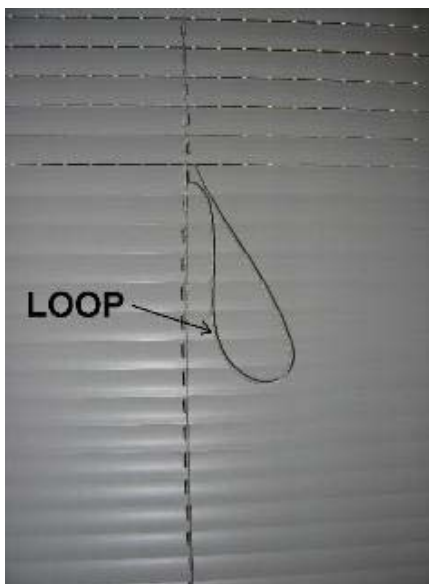

4. Victim strangled in a loop formed by tying multiple cords into a knot.

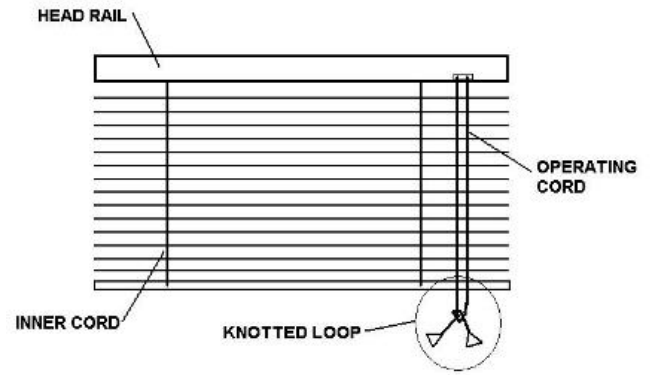
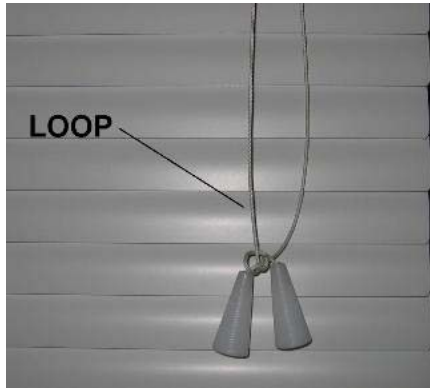

TYPICAL HORIZONTAL BLIND

5. Victim strangled in a cord (or cords) that was wrapped around the neck.

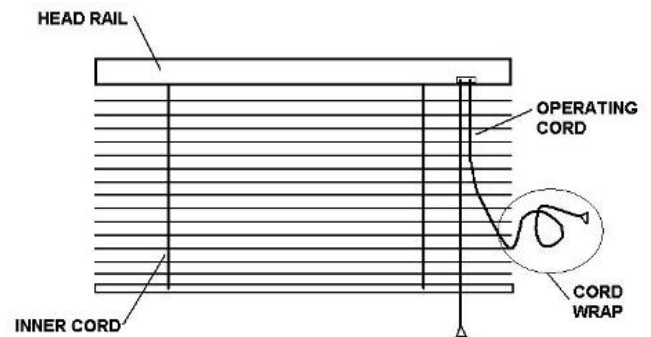
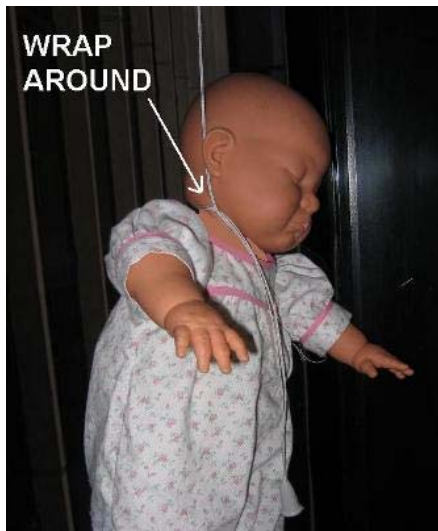

TYPICAL HORIZONTAL BLIND

B. Product Description and Hazard

Window blinds vary in design type and operation, and therefore have different cord strangulation hazards. The operating system determines how the window blind is raised/lowered and what types of cord hazards are present in the different cord configurations.

The three main operating systems for window blinds are:

1. Conventional Cord Lift
2. Continuous Loop Control
3. Cord Loop Lift

1. Conventional Cord Lift System

Description

Conventional cord lift systems are most often used on horizontal/Venetian blinds (see Figure 3), pleated/cellular shades, and roman shades.

The conventional cord lift operating system raises and lowers horizontal products using two or more cords that hang from the head rail of the blind. A locking mechanism in the head rail holds the blind in the raised position at any point along its length. The cords enter the head rail through the locking mechanism, then pass through the blind slats or fabric, and attach to the bottom rail. Cords that run through the slats are referred to as inner cords. The same cords on the other side of the head rail that are pulled to raise the blinds are called operating cords.

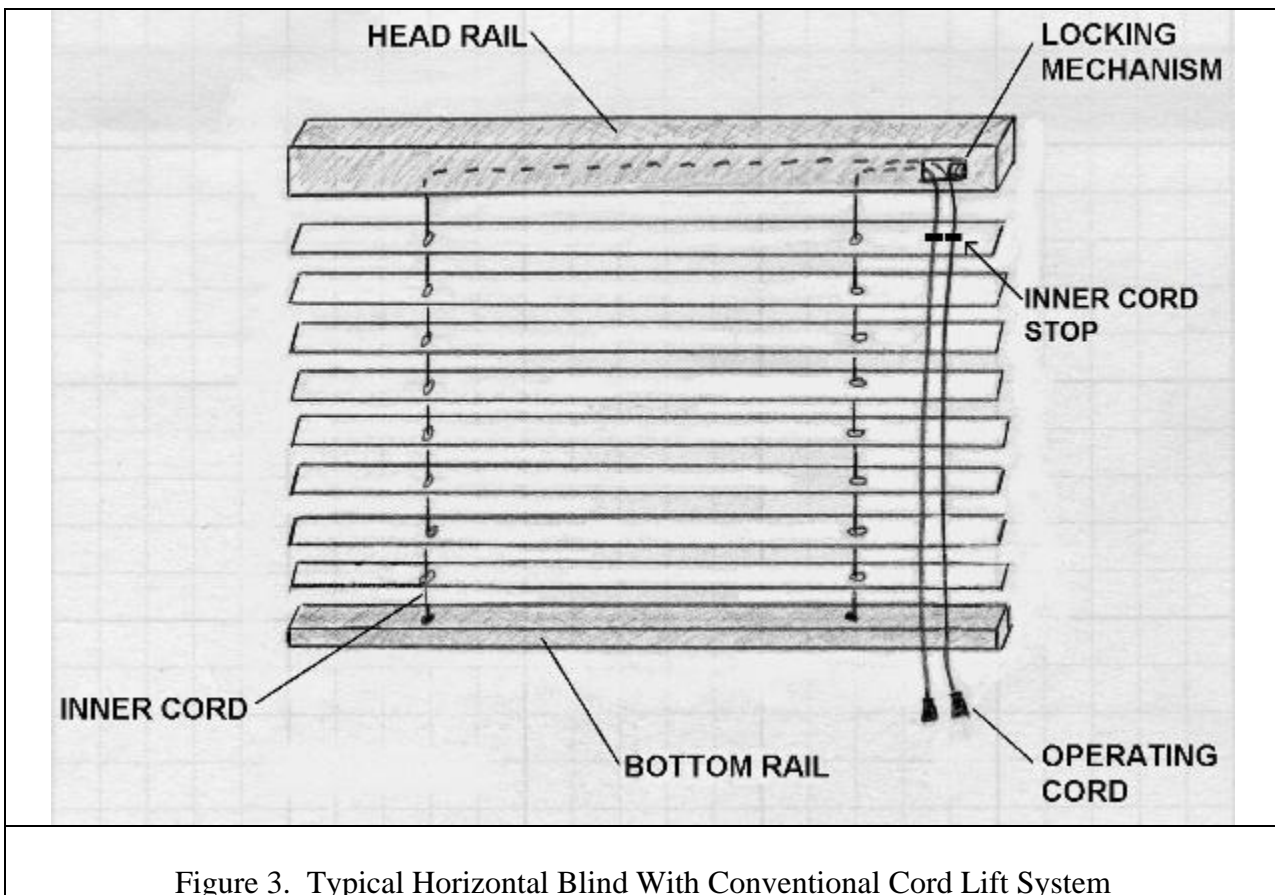

Figure 3. Typical Horizontal Blind With Conventional Cord Lift System

Hazards

The hazards associated with the **operating cord** of conventional cord lift systems are strangulation in:

- loops formed by two or more operating cords ending in a single tassel,
- loops formed by knots tied in two or more operating cords,
- loops formed by two or more operating cords tangling into a knot, and
- loops formed by tying an operating cord to an object such as a bed post or a cleat in the wall.

The hazard associated with the **inner cord** of conventional cord lift systems is strangulation in a loop formed by pulling down on the inner cord. A loop can also be formed by pulling up on the inner cord (and pulling the bottom rail up), but the majority of incidents involved strangulation in a loop formed by a downward pull on the inner cord as shown in Figure 4.

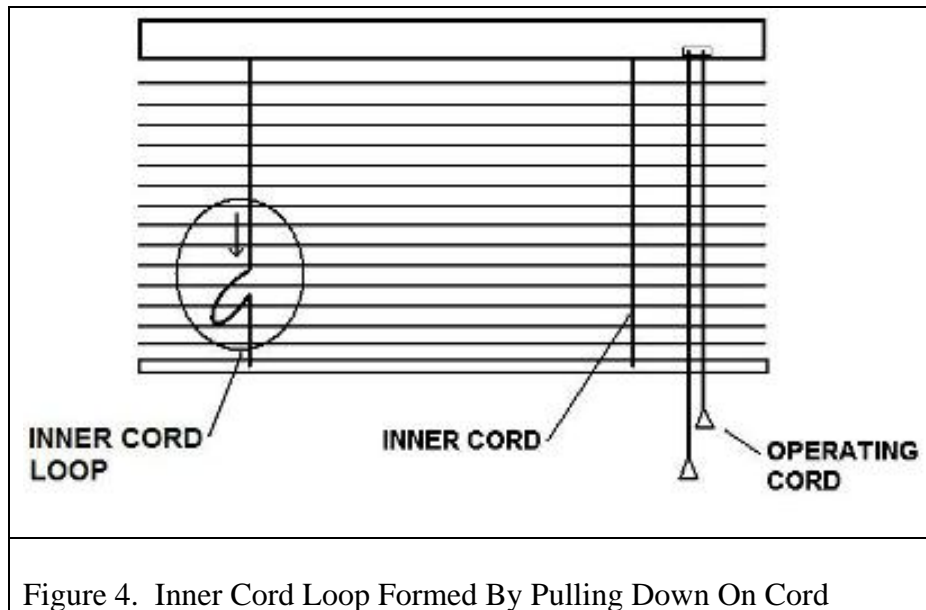

Figure 4. Inner Cord Loop Formed By Pulling Down On Cord

The inner cords of roman shades (see Figures 5 and 6) are particularly accessible because the cords run through rings or slots in the back of the shade that are spaced fairly wide apart (typically 8 inches) as shown in Figure 6. This large spacing creates the potential for a child to place his/her neck in the length of cord between the rings. Furthermore, some roman shades do not use a head rail with a locking mechanism to limit the movement of the operating cords, increasing the ease with which a loop can be formed by pulling down on the inner cord.

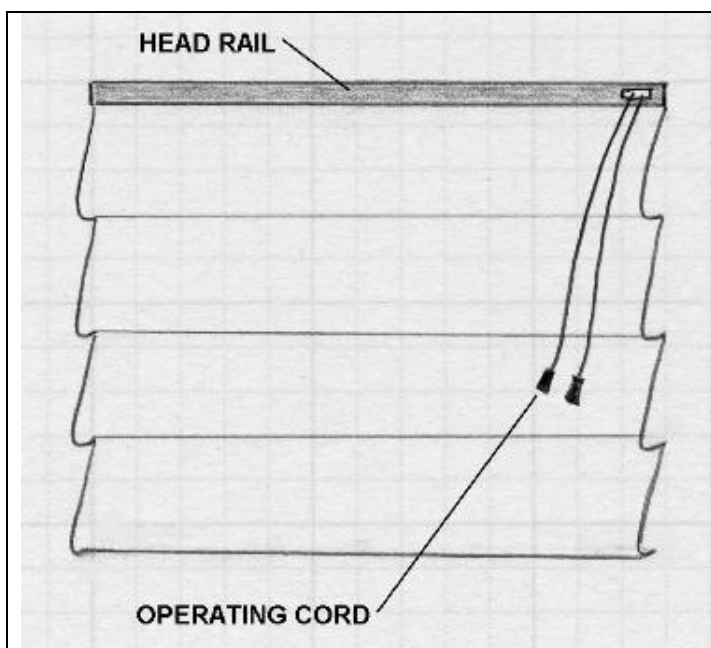

Figure 5. Typical Roman Shade (Front)

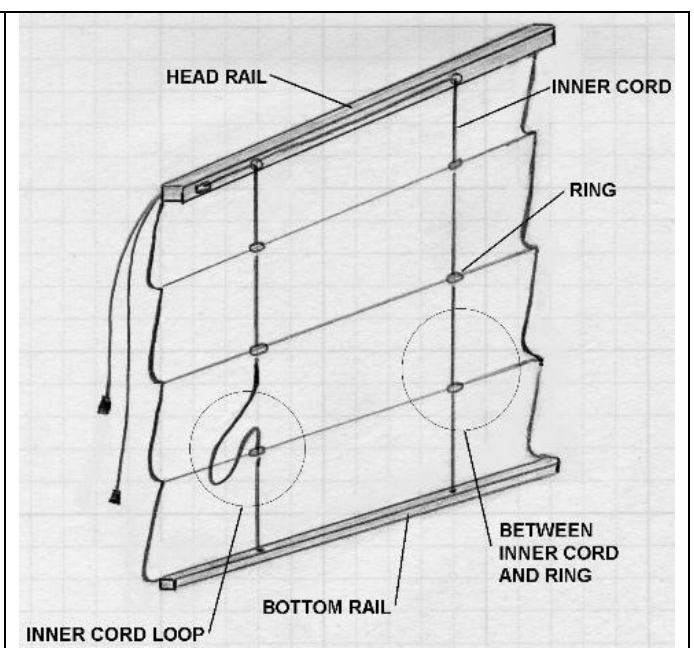

Figure 6. Hazards on Backside of Roman Shade

Safety Devices

Since 1996, conventional cord lift systems have been manufactured with a separate tassel at the end of each cord, or with two cords ending in a break away tassel that's designed to break apart if a child places his/her head in the tassel loop (see Figure 7). This safety strategy does not address consumers tying knots in the cords or tying the cords to an object.



Since 2001, conventional cord lift systems have been manufactured with inner cord stops (most often plastic donuts attached to the operating cords) to physically block the inner cord from being pulled out to form a loop (see Figures 8 and 9). The donuts are only effective if they are positioned less than 6 inches from the head rail. This safety strategy depends on the consumer to actively position the inner cord stops at the correct distance from the head rail. This safety strategy does not address the hazard posed by exposed inner cords on roman shades.

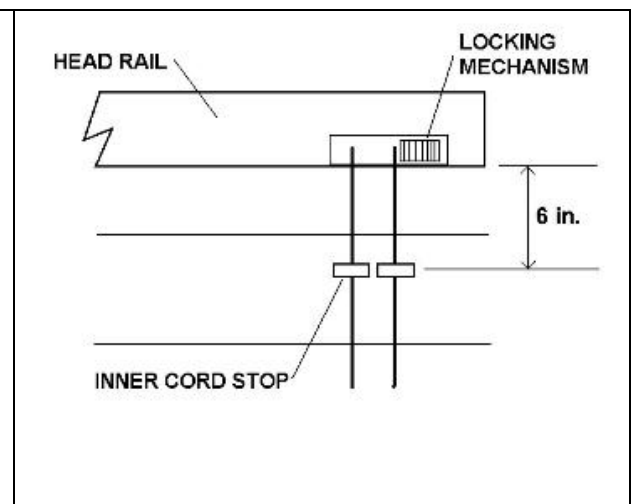
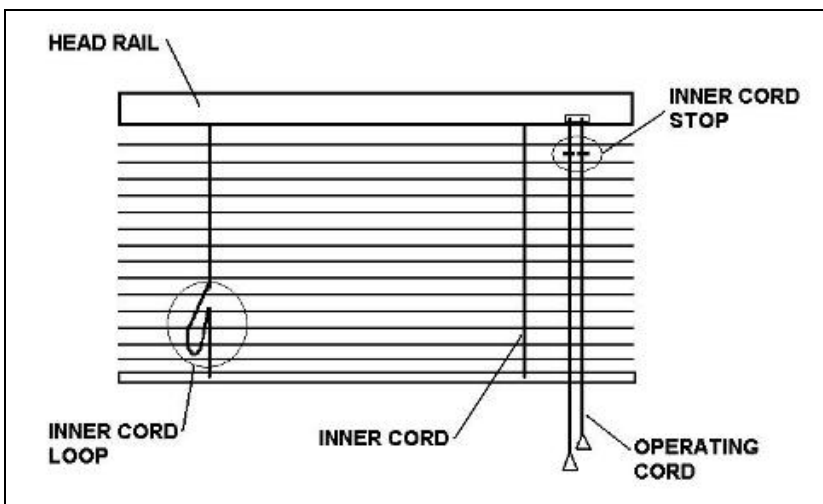

2. Continuous Loop Control

Description

Continuous loop control systems are most often used on vertical blinds (see Figure 10), drapes, and some horizontal type blinds such as roller shades.

A continuous loop control system consists of a head rail mechanism that is controlled by a continuous cord loop or bead chain loop. The mechanism in the head rail can move vertical coverings side to side (vertical blinds or drapes), rotate blind vanes open/closed (vanes of vertical blinds and horizontal blinds), or raise and lower horizontal coverings (roller shades).

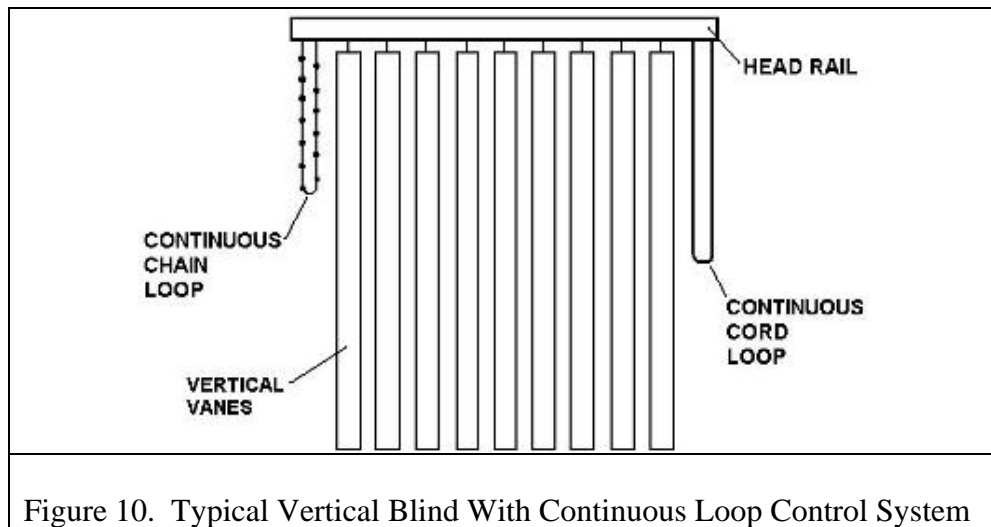

Hazards

The hazard associated with continuous loop control systems is strangulation in the free standing (not attached to the wall) continuous loop. Sometimes the consumer will also tie knots in the continuous loop cord.

Safety Devices

Since 1996, continuous loop control systems have been manufactured with a tension device attached to the continuous cord (see Figure 11). The consumer must mount the device to the floor or wall so that the cord loop is too taut for a child to place his/her neck in the loop. This safety strategy depends on the consumer to actively install the tension device at the correct distance from the head rail.

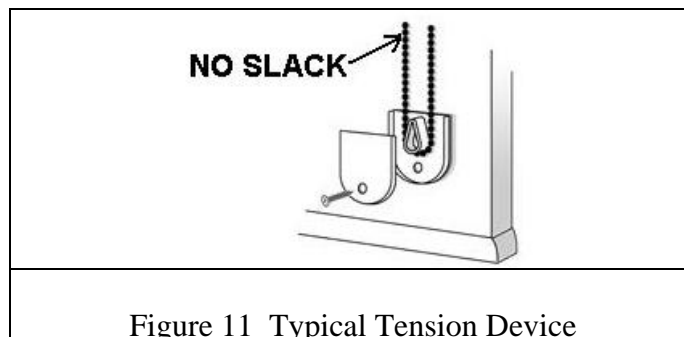

In 2002, CPSC staff and industry members reviewed fatal blind cord IDIs and concluded that all of the fatal incidents associated with continuous loop control systems could have been prevented if a tension device were properly used.

In 2007, the voluntary standard for blind cords was modified to require that continuous loop control systems be manufactured to be inoperable if the continuous cord loop is not tied down with a tension device. Although the voluntary standard was published in May 2007, manufacturers have not begun to meet this requirement.

3. Cord Loop Lift Systems

Description

Cord loop lift systems are used on roll-up blinds (see Figure 12).

Roll-up blinds consist of some type of flexible material that is rolled up and suspended by two cord loops (called the lifting loops). When the lifting loop cords are pulled, the loops rise, causing the flexible material to roll-up from the bottom of the blind. The cords that loop around the rolled window covering are referred to as the inner cords. The same cords on the other side of the head rail that are pulled to raise the roll-up blind are called operating cords.

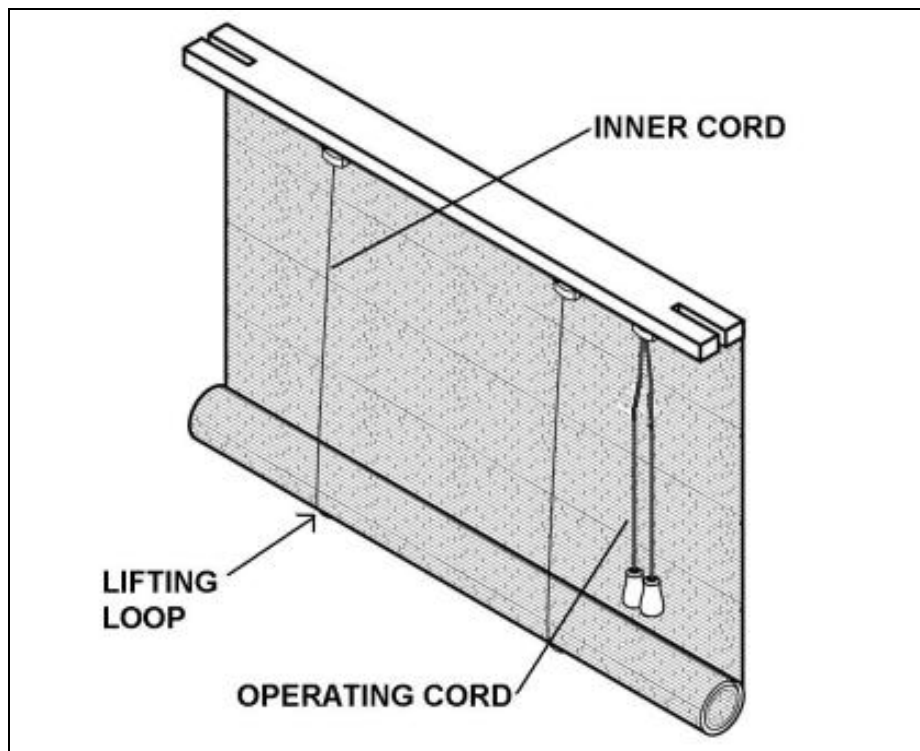

Figure 12. Typical Roll-up Blind With Cord Loop Lift System

Hazards

The hazards associated with the **operating cord** of cord loop lift systems are strangulation in:

- loops formed by two or more operating cords ending in a single tassel,
- loops formed by knots tied in two or more operating cords,
- loops formed by two or more operating cords tangling into a knot, and
- loops formed by tying an operating cord to an object such as a bed post or a cleat in the wall.
-

The hazards associated with the **inner cord of** cord loop lift systems are strangulation in:

- a free standing loop when the inner cord is pull off the side of the roll-up blind and
- strangulation in the loop that lifts the rolled up blind.

Safety Devices

Since 1996, cord loop lift systems have been manufactured with a separate tassel at the end of each cord, or with two cords ending in a break away tassel that's designed to break apart if a child places his/her head in the tassel loop. This safety strategy does not address consumers tying knots in the cords or tying the cords to an object.

Recently, some manufacturers have designed break away devices in the head rail of the roll-up blind that are intended to break away if a child places his/her neck in the loop that lifts the rolled up blind. Requirements for these devices have not been formalized in the voluntary standard.

B. Voluntary Standard

The voluntary standard for window blinds is ANSI/WCMA A.100.1 *American National Standard for Safety of Corded Window Covering Products*. The standard was developed in 1996, revised in 2001, and revised again in 2007.

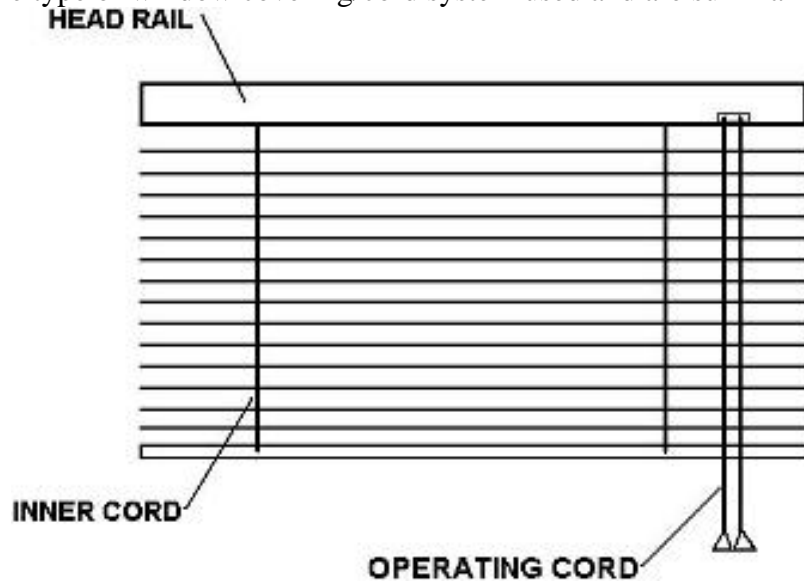

The voluntary standard requires safety devices on window covering cords that prevent access to a cord loop, prevent formation of a cord loop, or remove a cord loop before injury can occur. The safety devices depend on the type of window covering/cord system used and are summarized as follows:

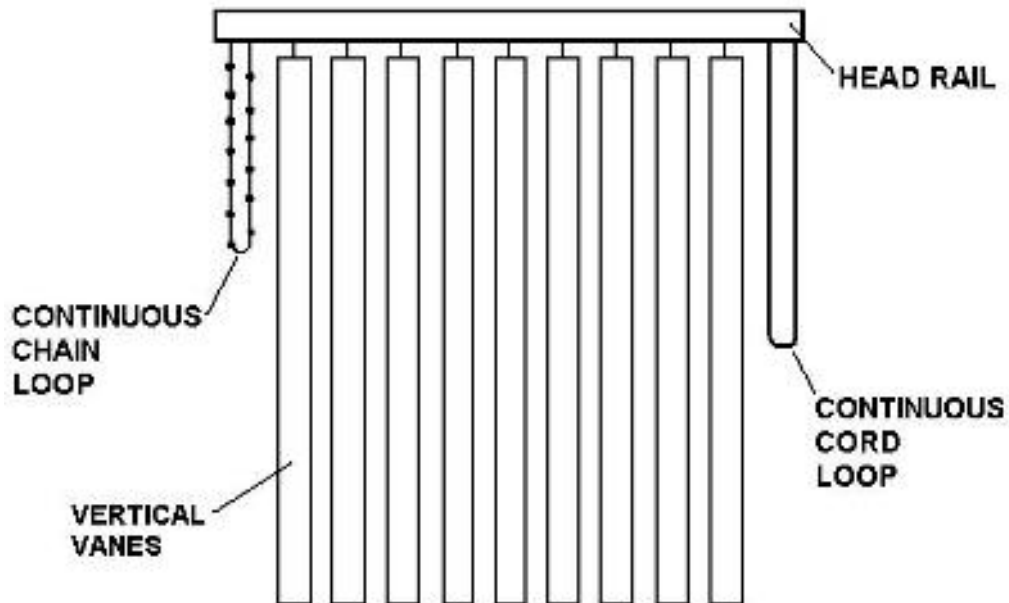

Typical Horizontal Blind

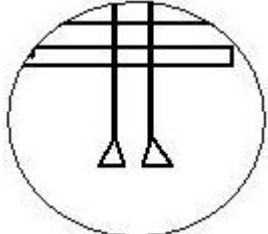

Typical Vertical Blind

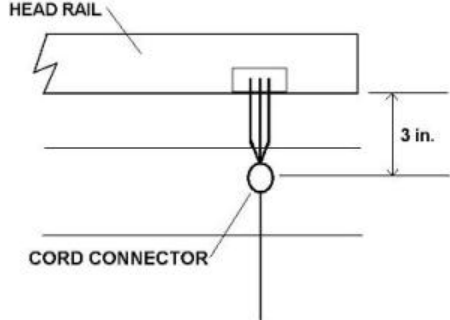
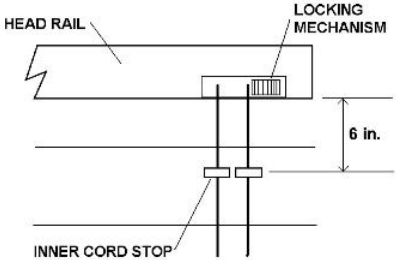
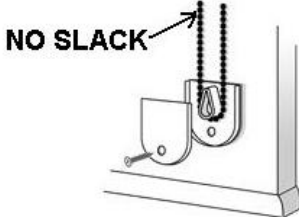
Blind Type	Component	Requirement	Description
Horizontal Blind [or any product with a conventional cord lift system]	Operating Cord	separate cords with separate tassels to avoid the formation of a loop...or	
		break away tassel in loop to remove a cord loop before injury can occur; the break away device can also be in the head rail but none are currently on the market...or	
		cord retraction device to roll up the operating cord and prevent access to a cord loop...or	there are no current products on the market but in theory the device would wind up the operating cord to within 6 inches of the head rail
		cord shear device to remove a cord loop before injury can occur...or	there are no current products on the market but in theory the device would cut the cord loop when a child places his/her neck in the loop
		cord connector that combines multiple cords to a connector with a single pull cord beneath, the connector must be less than 3 inches from the head rail when the blind is fully lowered	
Vertical Blind [or any product with a continuous loop control system]	Operating Cord	inner cord stop that prevents inner cord from being pulled out to form a loop; inner cord stop must be located less than 6 inches from the head rail; a mechanism in the head rail can also be used to prevent the inner cord from being pulled but none are currently on the market	
		tension device must be attached to continuous cord loop or chain; latest 2007 revision requires that the blind be inoperable if the tension device is not installed to the floor or wall	

C. Specific Items of Interest

Incidents involving window covering cords require information on what type of window covering was involved, what type of operating system the product used, which specific part of the cord was involved, how the loop was formed, how the cord was found around victim, year of manufacture of the product, and product conformance to the voluntary standard.

D. Headquarters Contacts

Renae Rauchschalbe (Office of Compliance)	301-504-7664
Caroleene Paul (Division of Mechanical Engineering)	301-504-7540

II. Instructions for Collecting Specific Information

A. Synopsis

Provide a complete and concise account of the incident including the product(s) involved, what part of the product was involved, who was injured, what the injury was, where the incident occurred, and the severity of the injury.

B. Description of the Product (see Appendix A Worksheet)

- What type of window covering was involved?
- Manufacturer and model of product. (information sometimes found inside head rail of product)
- Age of window covering product. When was it purchased? Manufacture date.
- Was the product used to cover a window or was it used some other way? (e.g. room divider)
- What type of operating system did the window covering use?
- Was the inner cord or operating cord involved in the incident?
- Was there a loop and how was it formed?
- What was the length of the loop from the point of suspension?
- What was the distance from the standing surface (floor, bed, etc.) to the bottom of the cord loop?
- What was the condition of the operating cord? Knotted, tied up, tied to something?
- Was the product damaged or modified before the incident? After the incident?
- If the product used a conventional cord lift system, were there inner cord stops installed on the operating cord? If so, how far from the head rail were the inner cord stops located (when the blind is in fully lowered position)?
- If the product used a conventional cord lift system, did the operating cords end in separate tassels or a break away tassel?
- If the product involved a roman shade, did the incident occur in the inner cords that run through the rings located on the back side of the shade? Did the victim pull down on the inner cord to form a loop or did the victim place his/her head between the inner cord and rings attached to shade?
- If the product used a continuous cord loop system, was a tension device present on the product's cord? If so, was the tension device properly installed to the floor or the wall?
- Were any warning hazard labels present on the product at the time of the incident or when the product was purchased? If yes, did the consumer read and understand the labels?
- Copy or photograph the label.

C. Description of Victim (see Appendix A Worksheet)

- What was the victim's date of birth and sex?
- What was the victim's height and weight?
- Did the victim wrap a single cord around his/her neck or did the victim place a loop over his/her head?
- If the victim was found in a cord loop, was it doubled around his/her neck?
- How did the child gain access to the cord? (e.g. climbed on sofa, crib near window, etc.)

D. Description of Accident Environment (see Appendix A Worksheet)

- Which room of the house did the incident occur? What was the layout?
- Was the window covering near furniture or a crib?
- What type of window was being covered by the product?
- What were the dimensions of the window?

III. Instructions for Photographing and/or Diagramming Incident Scene and Factors Related to the Accident.

- Photograph the whole window covering product involved in the incident (photos of exemplar products are only marginally useful--they cannot be used to make any determination on how incident occurred). This may involve photographing the incident sample at the police department.
- Photograph the specific part of the blind involved in the incident (cord, slats, etc.)
- Using a doll, photograph how the victim was found and in what part of the blind cord the victim was found.
- Take close-up photographs of blind cord loop (if present).
- Take close-up photo of operating cord ends (even if not involved in incident -- this helps us determine the age of the product and whether or not it meets the standard).
- Take close-up photo of cords at head rail. Be sure to include inner cord stops if present.
- Take photographs of cord condition -- knots, tangles, tied up to any objects, etc.
- Take photograph of any safety devices (tension device, inner cord stops, etc.) that were present.
- Take photographs of any warning labels.
- Obtain police photos of product and incident area.

IV. Instructions for Obtaining Samples and Documents Related to the Investigation

- Obtain police report.
- Obtain coroners report, or medical examiner's report/death certificate.
 - Was there a ligature mark around the victim's neck?
 - Describe the ligature mark. Did it encircle the neck or did it run ear to ear under the chin?
- Obtain incident sample or exemplar sample.

APPENDIX A

WINDOW BLIND CORD INVESTIGATION WORKSHEET

Window Blind Cord Investigation Worksheet

Headquarters Contacts:

Renaë Rauchschtalbe **301-504-7664**
Caroleene Paul **301-504-7540**

Description of Product

1. What type of window blind was involved? (circle one)

Horizontal Blind Vertical Blind Roman Shade Roll-Up Blind
Pleated/Cellular Shade Drapes Roller Shade Other _____

2. Manufacturer: _____

3. Date of manufacture: _____

4. When were blinds purchased? _____

5. Where were the blinds purchased? _____

6. Who installed the blinds? _____

7. Were the blinds used to cover a window or for some other purpose?

Windows Room Divider Cover Closet Other _____

8. What type of operating system did the window blind use?

Conventional Cord Lift Continuous Cord Lift Cord Loop Lift

9. Was the inner cord or operating cord involved in the incident?

Inner Cord Operating Cord

10. Was a loop in the blind cord involved?

Yes No

11. How was the loop formed?

Part Of Product Design Inner Cord Pulled Out Operating Cord Tangled Or Knotted

Other _____

12. What was the length of the loop?
Please write the length in the diagram.

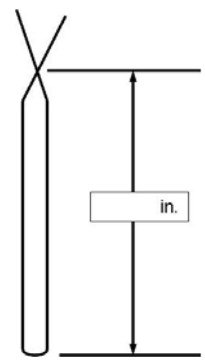

13. What was the distance from the standing surface (floor, bed, sofa, etc.) to the bottom of the cord loop? Please write in the distance in the diagram below. (Diagram shows a vertical blind.)

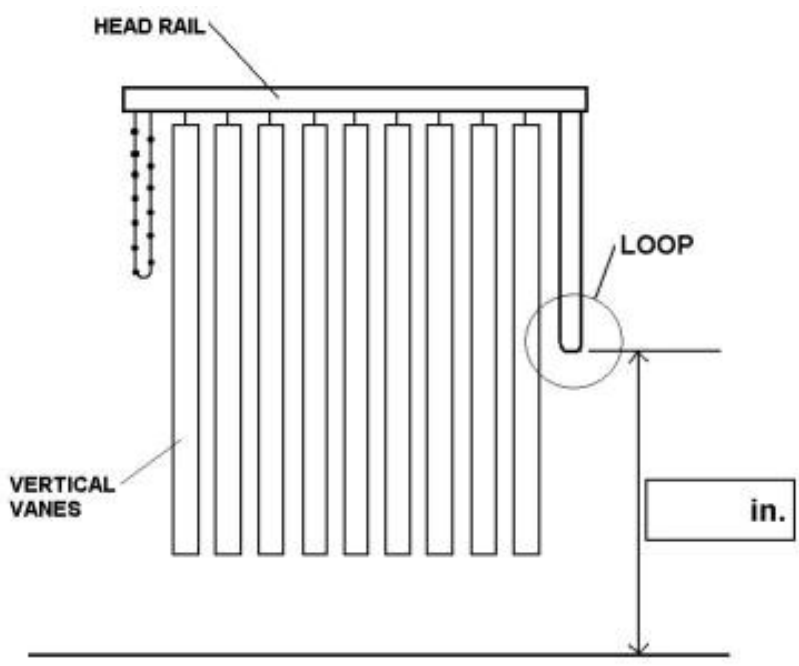

14. What was the condition of the operating cord, even if not involved in the incident?
Unmodified Knotted Tangled Other _____

15. Was the product damaged or modified before the incident?
No Yes, explain _____

16. Was the product damaged or modified after the incident?
No Yes, explain _____

17. If the blinds used a conventional cord lift system, were the inner cord stops installed on the operating cord?
Yes No

18. If inner cord stops were installed, how far from the head rail were the inner cord stops located when the blind is in the fully lowered position? Please write the distance in the diagram below.

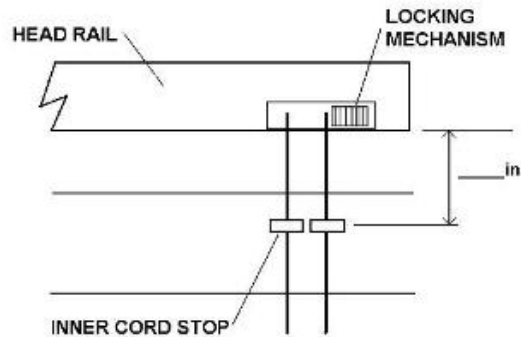

19. If the blinds used a conventional cord lift system, did the operating cords end in a single tassel, separate tassels, or a single break away tassel?

Single Tassel Separate Tassels Breakaway Tassel

20. What was the position of the blinds at the time of the incident?

Fully Raised Fully Lowered Partially Raised/Lowered

21. If the blinds involved were a Roman Shade, did the incident occur in the operating cords or the inner cords on the back side of the shade?

Operating Cords Inner Cords (Backside)

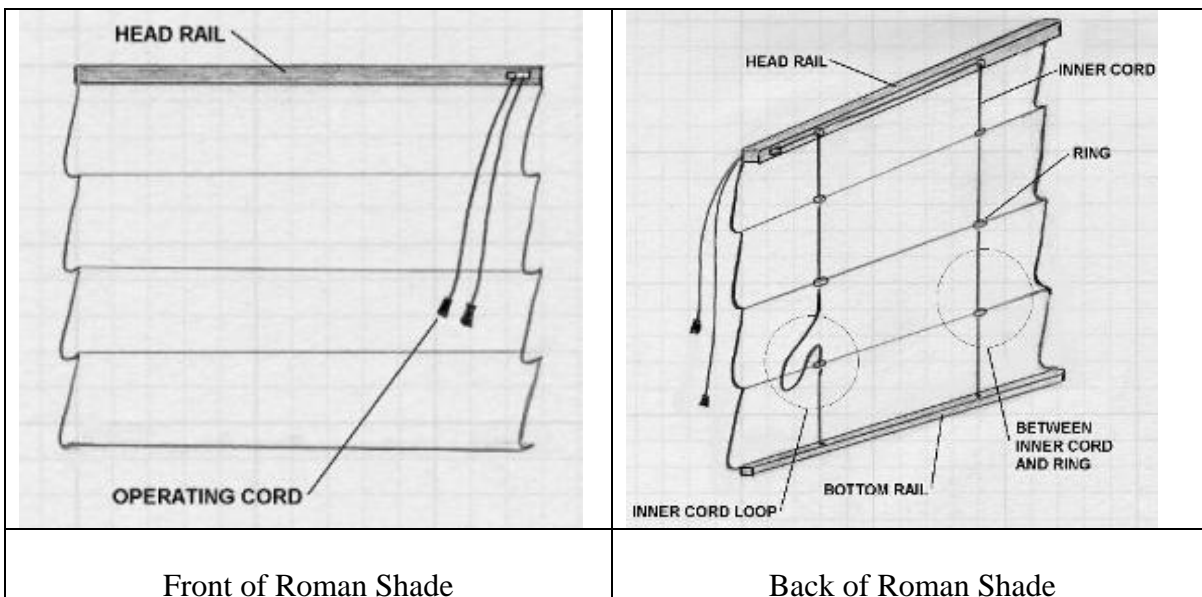

22. If the blinds involved the inner cords of a Roman Shade, did the incident occur in a loop formed by the victim pulling down on the inner cord or did the victim place his/her head between the inner cord and the rings attached to the shade (see Figure above)?

Pulled Down on Inner Cord

Placed Head Between Inner Cord and Ring

23. If the blinds used a continuous cord loop system, was a tension device present on the continuous cord? (see Figure below in Question 24)

Yes

No

24. If a tension device was present, was it installed to the floor or wall so that the cord is taut?

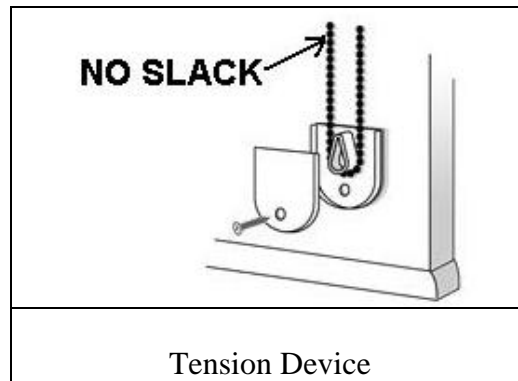

25. Who installed the tension device?

Professional Installer





Consumer

Other _____

26. Were any warning labels present on the product at the time of the incident? Were any warning hang tags present on the product at time of purchase?

Yes

No

 <p>WARNING</p>		<p>Cords and bead chains can loop around a child's neck and STRANGLE.</p> <ul style="list-style-type: none"> • Always keep cords and bead chains out of children's reach. • Move furniture away from cords and bead chains. Children can climb furniture to get to cords.
 <p>ADVERTENCIA</p>		<p>Las cuerdas y cadenas pueden envolverse alrededor del cuello de un niño y ESTRANGULARLO.</p> <ul style="list-style-type: none"> • Mantenga siempre las cadenas y cuerdas fuera del alcance de los niños. • Mueva los muebles lejos de las cuerdas y cadenas. Los niños pueden subirse a los muebles para llegar a las cuerdas.

Example of Warning Label

27. Did the consumer read and understand the warnings?

Yes No Comments _____

Description of Victim

28. What was the victim's date of birth? _____

29. What was the victim's sex? M F

30. What was the victim's height and weight? height = _____ weight = _____

31. Did the victim wrap a single cord around his/her neck or did the victim place a cord loop over his/her head?

Single Cord Cord Loop

32. Was the cord loop wrapped around the victim's neck more than once or was it a straight hang on the victim's neck?

Wrapped Around Neck Straight Hang

33. Was there a ligature mark around the victim's neck? (May need to reference coroner's report)

Yes No

34. Did the ligature mark encircle the neck or did it run ear to ear under the chin?

Encircled Neck Ear to Ear Other _____

Description of Accident Scene

35. In what type of dwelling did the incident occur?

Single Family Home Townhouse Apartment Mobile Home

Other _____

36. Did the incident occur in a home daycare facility?

Yes No

37. Which room in the house did the incident take place? _____

38. What type of window was covered by the product? _____

39. What were the dimensions of the window?

length = _____ inches height = _____ inches width = _____

40. How did the victim access the window covering cord?

41. Was the window blind near furniture or a crib? Yes No

42. If the window blind was near furniture or a crib, what was the distance from the blinds to the furniture or the distance from the blinds to the cribs? Please write in the distance in the diagram below.

