

**INVESTIGATION GUIDELINE**

January 1991

BicyclesI. IntroductionA. Background Information

Each year, there are an estimated one-half million bicycle-related injuries treated in U.S. hospital emergency rooms, based on data from CPSC's National Electronic Injury Surveillance System (NEISS). According to the National Safety Council, there are also about 1,200 deaths related to bicycles annually, about one-third of them children under the age of 15 years. It has been reported that as many as 75 percent of these deaths have been related to head trauma.

A CPSC mandatory standard containing design and performance requirements for bicycles was promulgated in 1975. However, it likely that the products, users, and usage patterns have changed considerably since that time. These factors, coupled with the large number of injuries that continue to occur, highlight the need for a current study to determine the circumstances involved in bicycle-related injuries. This information, in conjunction with relevant exposure data on bicycles and bicycle use, could then be used in future strategies for injury reduction, such as mandatory or voluntary standards activities, or the development and dissemination of information and education materials.

Thus, in FY 91 and 92, the Commission has scheduled a NEISS-based special study to identify the factors contributing to bicycle-related injuries treated in U.S. hospital emergency rooms. All sampled cases will be followed up by telephone investigations. Those in which the victim was wearing a helmet or there was a mechanical or structural failure of the bicycle will be reassigned for on-site visits. The investigation guideline for bicycle helmets (Appendix 107) should also be used when applicable.

B. Product Description

Bicycle can generally be classified under one of the following types: lightweight racing or touring; middleweight, utility, or cruiser; mountain, city, or all-terrain (ATBs); motocross (BMX) or free style; high-rise; or sidewalk. See Figures 1-6. A list of accepted bicycle terminology is provided in Attachment A of this guideline.

1. Lightweight racing or touring

These bicycles are generally made of lighter weight tubing, and have between 3 and 18 speeds. (The number of gears a racer has is determined by multiplying the number of front sprockets by the number of rear sprockets.) The frame is most often in the diamond configuration. The handlebars are usually "dropped" (hand grips on a lower place from the handlebar clamp). The tires are high pressure (75+ pounds per square inch) and narrow (1-1/4 inches). These models normally have no fenders.

2. Middleweight, utility, or cruiser

These bikes are typically made of a heavy gauge of tubing. Tire size is large (2-1/8, 1-3/4, or 1-1/2 inch cross section) and tire pressure is low, typically under 50 psi. Fenders are often present over both tires when the bicycle is new. A single-speed hub is most common, but three-speed models are also sold. The handlebars are upright (not raised or dropped), with hand grips on a slightly elevated plane from the handlebar clamp.

3. Mountain, city, or all-terrain (ATBs)

This fast-growing category of bicycle features upright handlebars, a wide padded seat, and multi-speed gearing. Shift levers are usually mounted on the handlebars. Wheel size ranges from 20 to 26 inches, with tire cross section width from 1-1/2 to 2-1/8 inches. These bikes may have a knobby tire tread pattern to allow for riding both on-road and off-road, on rough terrain.

4. BMX or free-style

The BMX (bicycle motocross) or free-style bicycle is very popular among children. This bicycle has small wheels, usually 20 inches or less, and wide tires (1-1/2 or more inches). While similar to high-rise bicycles (see definition below), BMX's are often more rugged, and have a smaller, more triangular seat. The handlebars are usually high-rise (hand grips on a much higher plane from the handlebar clamp), with a reinforcing crossbar. Most bicycles are single-speed, and may have a coaster brake, hand brakes, or both.

5. High-rise

This model is usually designed for children. Distinguishing features include: high-rise handlebars, banana seat (elongated seat that enables the rider to shift his weight over the rear wheel), small wheels (usually 20 inches or less), and wide tires.

## 6. Sidewalk

These bicycles, with wheels 20 inches or less (and seat height no more than 25 inches, with the seat adjusted to its highest position), are designed primarily for small children. Sidewalk bicycles are often equipped with training wheels when new. While some sidewalk bikes have a direct chain drive with no brakes, most sidewalk bicycles are equipped with coaster brakes.

### C. Specific Items of Interest

Information is needed on the effectiveness of the CPSC mandatory safety standard for bicycles, as well as on the patterns of hazards associated with bicycle use. Of particular interest are incidents in which there was mechanical or structural failure of the bicycle. The relative levels of safety offered by various designs of bicycle helmets, child carriers, and other accessories are also of interest.

### C. Headquarters Contacts

Deborah Tinsworth, EPHA 492-6470  
John Preston, ESME 492-6494

## II. Instructions for Collecting Specific Information

### A. Synopsis

Provide a brief summary of the accident sequence. Report the type of bicycle involved in the accident. Indicate the factors that contributed to the accident, such as product failure, collision, loss of control, surface hazard, high speed, stunting, etc. Report whether those involved were wearing helmets or not. For data retrieval from the computer, please include the following key words as appropriate: touring, racer, middleweight, utility, cruiser, mountain, city, all-terrain, BMX, free-style, high-rise, sidewalk, break, broke, failure.

### B. Description of the Product

Please obtain the following information:

1. The bicycle type (e.g., BMX, high rise, etc.)
2. The style of handlebars (e.g., "upright" or "straight," as on middleweight or all-terrain bicycles; "highrise," as on a BMX; or "dropped," as on a racer)
3. The number of speeds available (e.g., one, three, twelve, etc.)
4. The type of brakes; i.e., coaster, caliper (specify whether center pull, side pull, or cantilever), or combination. Did the brakes have extension levers? Describe the condition of the brake blocks and cables.

5. The type of wheels (e.g., spoke, plastic, disk)
6. The width, diameter (read information off side wall) and condition of tires. Were they relatively smooth or knobby?
7. The location of shift levers, if present; i.e., down tube, stem, handlebars (specify whether near center, inside grips, or on ends of bars).
8. The pedal type (rubber blocks, rat trap, etc.) and condition.
9. The number, location, color, and condition of reflectors (front, rear, front wheel, rear wheel, pedals, etc.). If reflectors were not present, ask why was so; e.g., removed for racing, not present when bicycle was purchased, etc.
10. Whether there were lights on the bicycle or bicycle operator, and whether they were in use at the time of the accident. Indicate type (generator vs battery), and location (e.g. front or rear of the bike, on the rider, etc.).
11. Whether the bicycle was equipped with a chain guard.
12. The brand, model, and manufacturer of the bicycle.
13. The approximate date of purchase and purchase price. If purchased used, please indicate the length of time the current owner had the bicycle.
14. The type of store from which the bicycle was purchase (e.g. bicycle shop, discount store, department store, etc.)
15. By whom the bicycle was assembled (consumer, retailer, manufacturer, independent assembler, etc.), and the extent of assembly required.
16. The general condition of the bicycle; e.g., like new better than average; abused, rusted, needed overhaul, etc.
17. How the bicycle was usually maintained (andy by whom), how often the maintenance was performed, and what the maintenance consisted of.
18. Any previous problems with the bicycle. If repairs were performed, please describe and report who performed them (e.g., parent, bike shop, etc.). Indicate if the design or structure of the bicycle had been modified or changed in any way.
19. Whether a structural failure was involved. If so, report whether the failure was of a mechanically tightened joint such as a bolt, of a weld, or of the material itself. Photograph the exact spot of the failure, with a close-up of the broken pieces, if possible.

20. If a failure was involved, the brand name and model of the component, and whether it was purchased separately or was original equipment.
21. The frequency and duration of bicycle use for the bike involved, and how the bicycle was used (e.g., off-road dirt bike racing, riding on paved street, etc.)

C. Description of the Incident Environment

Supply information about:

1. The terrain and surface on which the user was riding at the time of the accident.
2. The weather conditions, including temperature, precipitation, and visibility.
3. The condition of the riding surface at the time of the accident (e.g., slick from gravel, water, ice, leaves; uneven with ruts, bumps, potholes; etc.)
4. The presence or absence of pedestrians, animals, other bicycles, or motor vehicles, and their role or involvement in the accident.
5. The location where the accident occurred (.e.g., sidewalk or playground; neighborhood street with low traffic volume; highway or street with high traffic volume; bike path, indicating whether on or separate from roadway' unpaved road; other unpaved surfaces or trails; etc.)
6. Anything in the accident location that would impair the vision of the bicyclist or motorist, if this might have been a contributing factor; e.g., tall bushes at corner, lack of street lighting, truck parked near corner, etc.
7. Time of day lighting condition.

D. Description of the Injured Person(s) and Product Interaction

Include the following:

1. The age, sex, height, and weight of each victim, as well as any other body measurements, physical impairments (including fatigue, and alcohol or drug use), or other factors which might relate to the accident.
2. Whether the victim was the operator of the bicycle, a passenger, or a non-rider.
3. Whether the victim was riding the bike with an infant or young child as a passenger.
4. The victim's and/or other individual's perception of what occurred during the accident sequence, including any factors which appeared to contribute to the accident (e.g., slippery or uneven riding surfaces; collisions with moving or non-moving objects;

something caught in the spokes of the bicycle; bicycle going too fast; operator was performing stunts; part of bicycle broke or didn't work properly; etc.).

5. A description of anything the victim (or others) may have done to contribute to or avoid the accident.
6. If the victim was a passenger, whether he or she was in a child carrier (if so, describe the carrier, and indicate whether or not the victim was wearing a helmet.
7. The user and/or victim's experience with bicycling, particularly within the last 12 months.
8. The user and/or victim's experience with this bicycle.
9. A description of any previous bicycling accidents the user and/or victim was involved in.
10. A description of the victim's clothing at the time of the accident, including footwear.
11. A description of any safety gear such as helmet, gloves, warning bell or horn, reflective clothing, rear view mirror, etc., which were being used at the time of the accident. If a helmet was worn, report manufacturer, brand, and model, if known, and whether the user felt that the helmet had any effect on the severity of the injury. Describe the fit of the helmet, if possible. If the victim was not wearing a helmet, determine if the victim/user owned one, and why it was not being worn at the time of the accident. (Also be sure to refer to the investigative guideline for bicycle helmets, Appendix 107.)
12. Whether the user and/or victim was listening to a cassette player, radio, or other device with earphones at the time of the accident.
13. Whether the user and/or victim was carrying anything at the time of the accident, and where' e.g. in hands, on back, or on bicycle rack, or in front or rear baskets or packs.
14. A description of the nature and severity of any injuries incurred in the accident. If the victim's injury involved the head or face area, please describe the part(s) of the head or face that were injured, the type(s) of injury that occurred, the treatment received at the hospital, and if there were any lasting or permanent effects due to the accident. Note if the victim experienced any symptoms such as blurred vision, headaches, or nausea.

E. Product Safety Standards

For information on mandatory requirements, please refer to the CPSC regulations on bicycles under the Federal Hazardous Substances Act.

III. Instructions for Photographing and/or Diagramming Factors Related to the Investigation

1. Photograph the whole bicycle from both sides, and provide close-ups of the parts specifically involved in the accident or which may have contributed to the accident.
2. If possible, photograph the victim next to (side view) and on the bicycle so we can see the relative sized of the two.
3. Photograph any relevant labeling on bicycles, accessories, or user manual, if available.
4. Photograph the terrain on which the accident took place, if possible.
5. If a motor vehicle was involved, diagram the roadway where the accident took place, including the locations of themotor vehicle and bicycle during the accident sequence.

IV. Instructions for Obtaining Samples and Documents Related to the Investigation

Obtain any police, medical, coroner, or other reports of the accident.

## Attachment A

Definitions: In order to insure that proper terminology is used when describing bicycle features, a list of accepted bicycle terminology is provided below:

- (1) Axle: The threaded rod, located inside the hub, on which the wheel rotates.
- (2) Barrel adjustor: An adjusting screw, located on the brake caliper or brake lever, that changes the relationship of the cable housing length to the length of the brake cable.
- (3) Bicycle: A two-wheel vehicle having a rear drive wheel that is solely human powered.
- (4) Bottom bracket shell (or crank hanger): The part of the bicycle which holds the crank arms (or axle) in the frame and lets them (or it) spin freely.
- (5) Brake cable: A cable that passes through the cable sheath and is attached to the front or rear hand brake lever at one end and the caliper brake mechanism at the other end.
- (6) Brake caliper: A mechanical device mounted near the wheel rims used to apply force to the wheel rim so as to stop or slow the forward motion of the bicycle.
- (7) Brake hand levers: Levers mounted on the handlebars to actuate the front and rear caliper brakes.
- (8) Brake lever clamp: A device that clamps the brake hand lever to the handlebars.
- (9) Brake shoe: (Sometimes referred to as a brake block or brake pad). A piece of material attached to the caliper brake arm used to transmit the braking force to the bicycle rim. The pad material must produce frictional forces when applied to the wheel rim in order for the brakes to work.
- (10) Cable anchor bolt: A clamping device for holding the brake cable to the caliper brake arm.
- (11) Cable hanger: A bracket used in conjunction with a center pull caliper brake system for holding the brake cable barrel adjustor in place.
- (12) Cable housing: The material through which the brake and derailleur gear cables pass.
- (13) Caliper brake system: A brake caliper, a hand-actuated lever, and a cable and sheath assembly designed to transfer the applied force at the hand lever to the brake caliper.
- (14) Chain: A set of inter-connected links used to transmit power from the front sprocket or chain ring(s), to the rear wheel at the rear sprocket(s).



- (15) Chain guard: A device used to shield the front sprocket (s) and chain.
- (16) Chain stays: The section of the frame from the bottom bracket to the rear fork ends.
- (17) Clincher tire (or wired-on tire): A tire which seats closely against the rim's inner surface. Some of these tires have no tubes and are used with either a straight sided rim or a "hooked bead" rim held in place with air pressure.
- (18) Coaster brakes: Foot brakes, actuated by a reverse movement of the bicycle crank, usually found on bicycles with a single front sprocket and a single rear sprocket.
- (19) Control cable: A cable used to transmit forces which shift the bicycle into different speeds.
- (20) Crank arm: A device with pedals attached, located in the crank hanger, which transmits human power to the bicycle's drive mechanism.
- (21) Crank hanger: (see bottom bracket shell).
- (22) Crank set: The part of the bicycle consisting of the crank arms, spindle, drive sprocket and miscellaneous hardware.
- (23) Derailleur: A gear changer, located at the front and/or rear of the bicycle which moves the chain from larger to smaller sprockets or vice versa, thus increasing or decreasing the gear ratio.
- (24) Derailleur cage: A device that holds the rear derailleur idler and jockey roller.
- (25) Down tube: The part of the frame extending from the head tube to the bottom bracket shell.
- (26) Drive train system: A system primarily comprised of a chain, crank, pedals, and sprocket wheels used for transmitting human power to the rear wheel of the bicycle. On multi-speed bicycles, includes derailleurs and/or internal gear hubs.
- (27) Extension levers: See had lever extensions.
- (28) Fenders: The mud guards positioned over the back of the front wheel and front of the back wheel.
- (29) Fork ends or "drop outs": Pieces that are attached to each seat stay, and the chain stay into which the rear wheel axle fits. In the front of the bicycle the fork ends are attached to each fork blade.

- (30) Frame: The primarily structural component of a bicycle, made up of the to tube,
- (31) Freewheel: A device usually on or in the rear hub that permits the rear wheel to go on turning when the pedals are stopped. Also refers to the cluster of sprocket rings (3-7) mounted on the rear hub of many multi-speed bicycles.
- (32) Front fork: The structure holding the front wheel fork ends, which is turned by the handlebars to steer the bicycle. Included in this unit is the fork stem or steer tub (inside the head tube), fork legs, and fork ends.
- (33) Handgrips: The part mounted on the handlebar that is gripped to steer the bicycle (may be foam, plastic, cloth, or leather).
- (34) Handlebar stem: (sometimes referred to as a "gooseneck" or "extension.") Usually a metal piece, the top section of which holds the handlebars while the bottom part is attached to the inside of the fork stem or steer tube.
- (35) Handlebars: The part of the bike used by the rider to control the front wheel. The handlebars may be held in place by a handlebar stem, constructed of a single piece which fits directly into the fork stem.
- (36) Hand lever: A lever on the handlebars which is used to apply the brakes.
- (37) Hand lever extensions: Auxiliary braking levers used on some bicycles with dropped handlebars.
- (38) Headset: A device consisting of washers, bearings and bearing races, which is used to join the fork to the frame.
- (39) Head tube: The tube holding the front fork and fork bearings, into which the top and down tubes are attached.
- (40) Hub: The front or rear wheel part that has spokes attached to its outside and an axle and bearings mounted inside. Rear hub may also contain a coaster brake and an internal gear mechanism.
- (41) Idler roller: (Sometimes called a tension roller) The pulley or roller that idles loosely on the shaft to take up the chain slack. Usually part of a rear derailleur system.
- (42) Jockey rollers: A small sprocket wheel used in the derailleur mechanism for applying tension to the chain.
- (43) Lugs: The metal reinforcements used at the intersection of some frame members. A frame with lugs is a lugged frame.

- (44) Non-pneumatic tires: Tires not having a rubber inner tube, and which are made of solid or semi-solid material.
- (45) Pneumatic tires: Air inflated tires that usually have a rubber inner tube.
- (46) Pedals: The part of the bicycle assembly on which the foot pushes (and/or pulls) in order to transmit power to the bicycle. Pedals attached to crank arms.
- (47) Quick release lever: A mechanism that permits quick removal of the front or rear wheels. Similar levers may also be found on seat post clamps and handlebar clamps for adjustment of these parts of the bicycle.
- (48) Rear derailleur idler: A small sprocket wheel used in the derailleur mechanism for taking up chain slack.
- (49) Reflectors: Devices used to transmit light back towards an emitting source.
- (50) Rim: The wheel, less the spokes and hub, on which the tire is mounted. The rim is the part of the bicycle to which one end of the spokes are attached.
- (51) Seat or saddle: The part of the bicycle on which the operator sits when riding in a normal fashion. Attached to the frame via the seat post.
- (52) Seat mast (or seat tube): The part of the frame into which the seat post is placed and which extends from under the seat to bottom bracket shell.
- (53) Seat post: A tube or rod which is clamped into the seat mast and, to which the seat is clamped or otherwise attached.
- (54) Seat stays: The rear part of the frame extending from the intersection of the top of the seat mast to the rear fork ends.
- (55) Spokes: The wires that are attached to the flanges of the hub at one end, and through the rim at the other end.
- (56) Spoke nipples: The devices which are used to connect the spokes to the rim of spoked-wheel bikes.
- (57) Sprocket: (Chainwheel) A wheel with gear teeth, used to drive the bicycle chain when pedaling.
- (58) Toe clips: The cages and/or straps on the pedals that hold the rider's feet in position.
- (59) Top tube: The frame member between the seat mast and the head tube.

(60) Tubular tire: Also known as the "sew up" tire, incorporates the tire and tube into one unit, and is cemented to the rim.

(61) Wheel locking device: A locknut, nut, and lockwasher; quick release lever; or other device used for preventing the wheel axle from separating from the bicycle frame or fork.

(62) Wheels: Are made up of an axle, a hub with bearings, spokes, spoke nipples, possibly a rim strip, tire and tube. Some wheels are made of plastic and have no metal spokes.

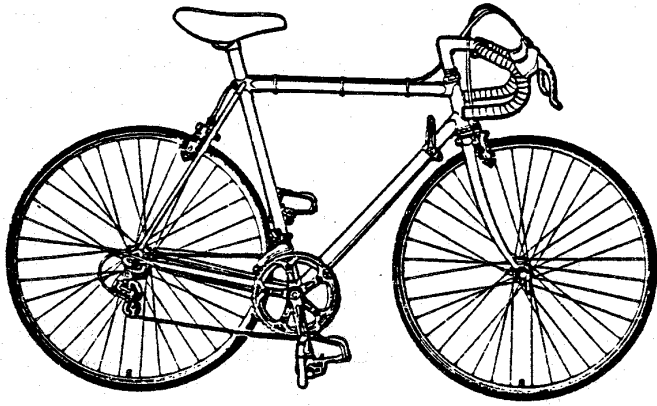

MULTI-SPEED, LIGHTWEIGHT, TOURING OR RACER

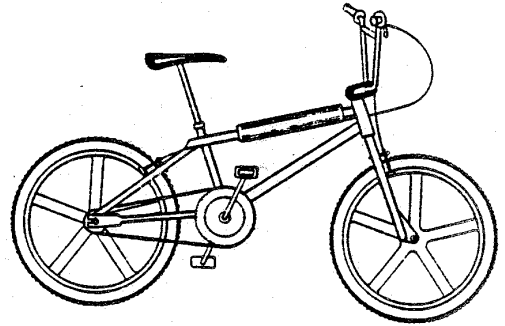

BMX OR FREE-STYLE

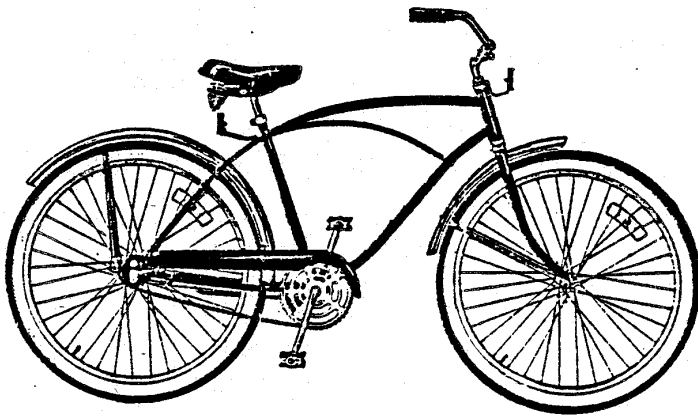

MIDDLEWEIGHT, UTILITY OR CRUISER

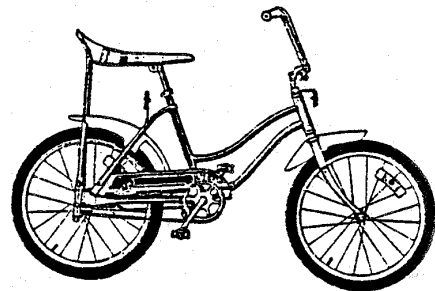

HIGH RISE

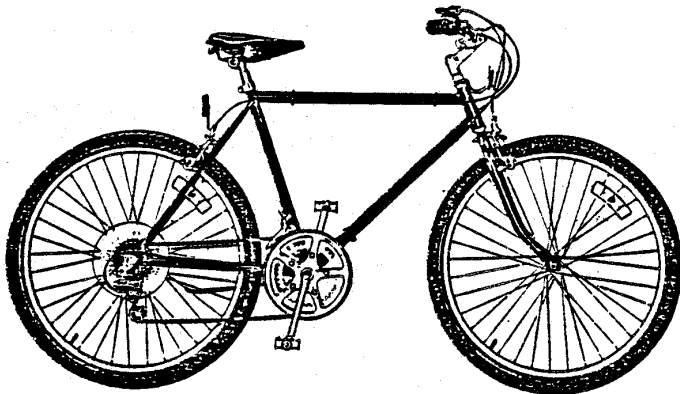

MOUNTAIN, CITY OR ALL-TERRAIN

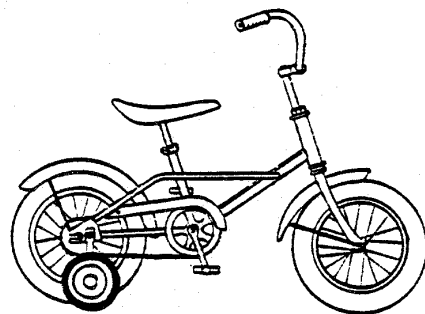

SIDEWALK

FIGURE 1. TYPES OF BICYCLES

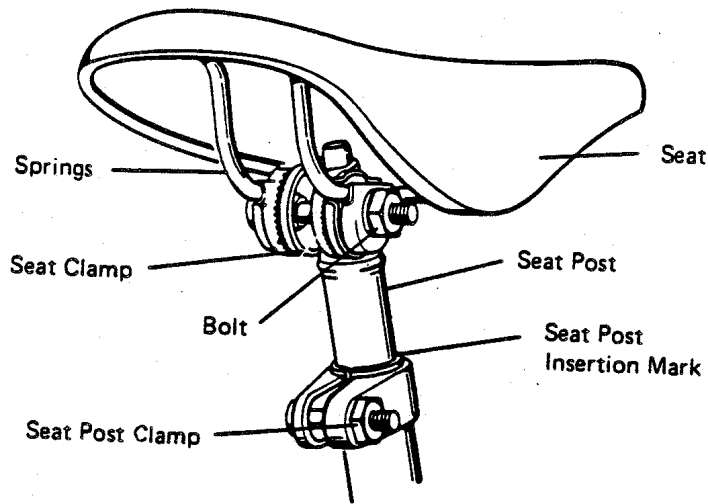

FIGURE 2. SEAT

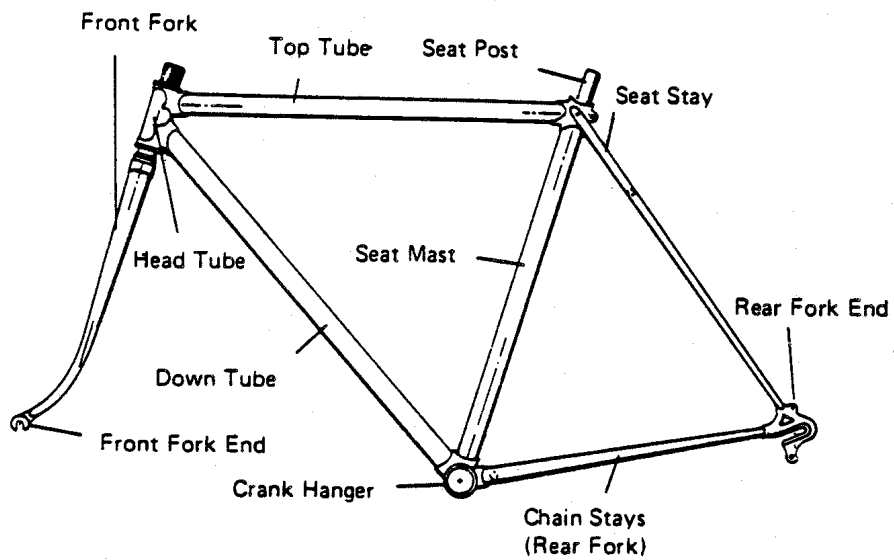
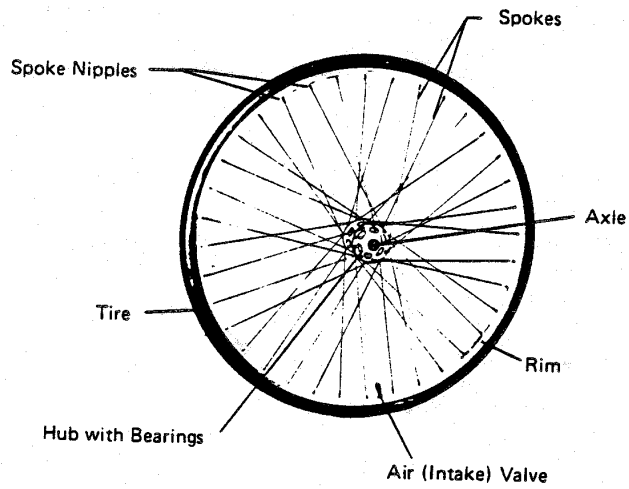
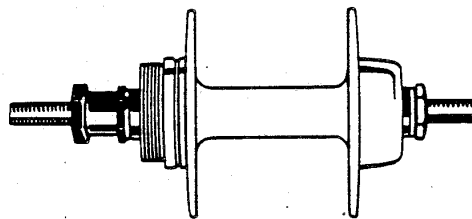

FIGURE 3. FRAME SYSTEM  
(diamond configuration)



Parts of Wheel



Hub

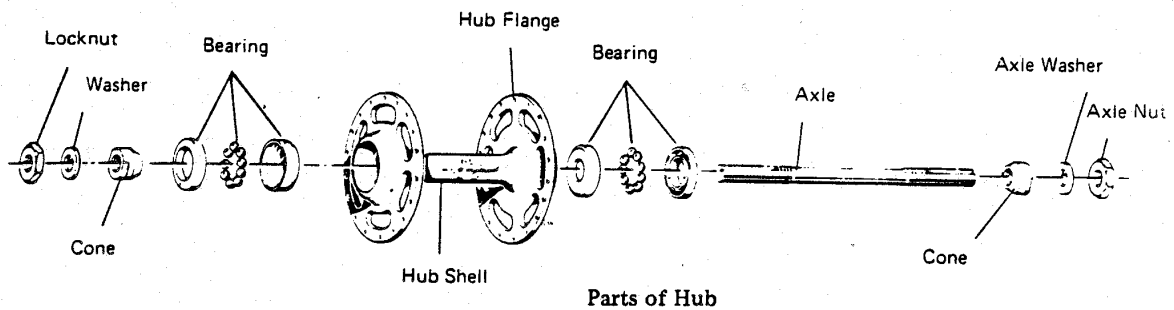

Parts of Hub

FIGURE 4. WHEEL SYSTEM

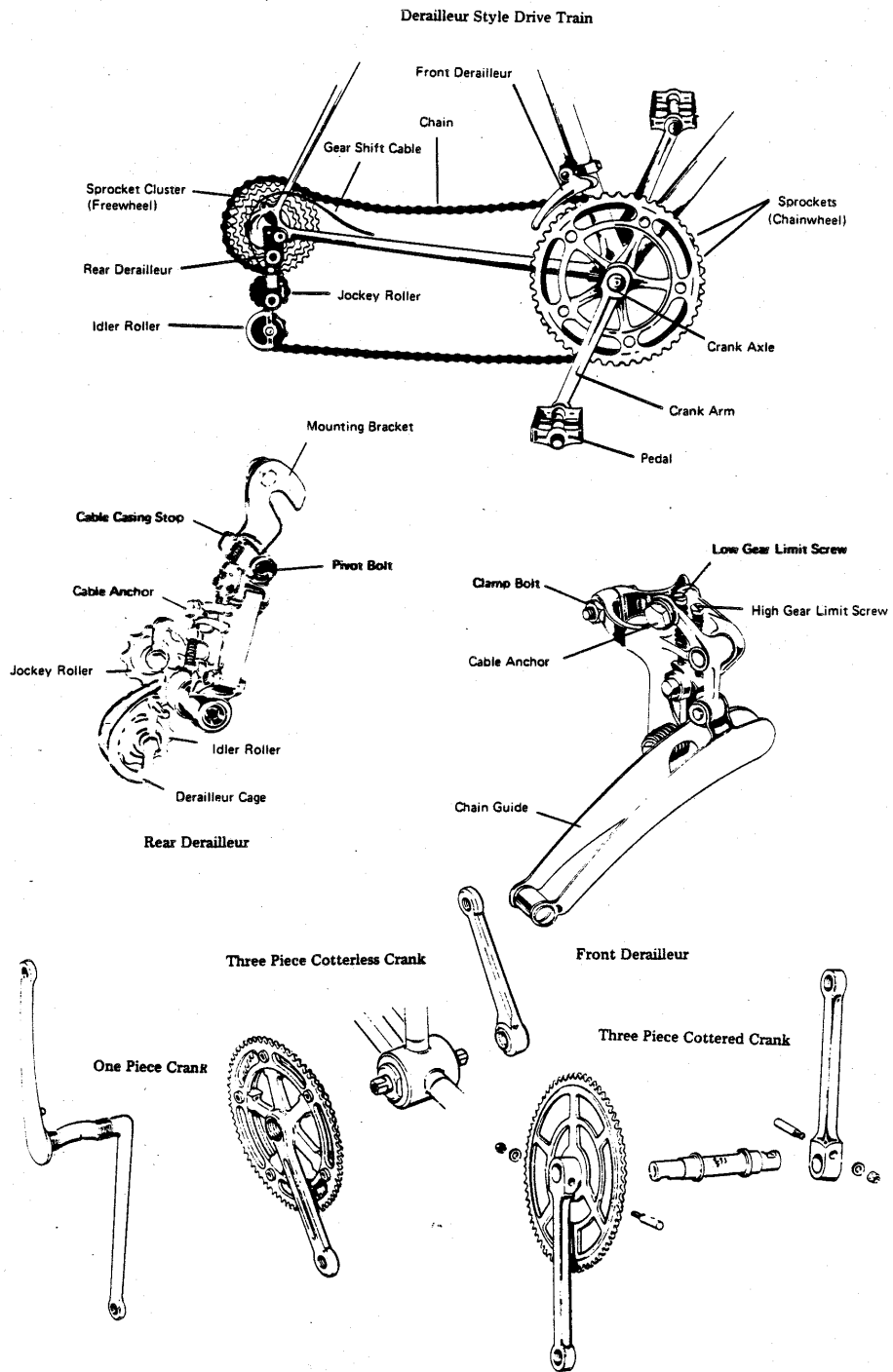
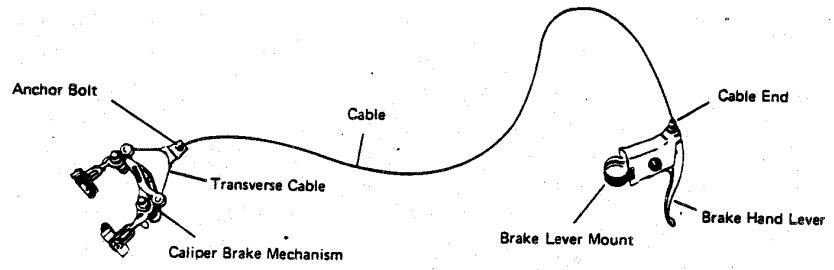
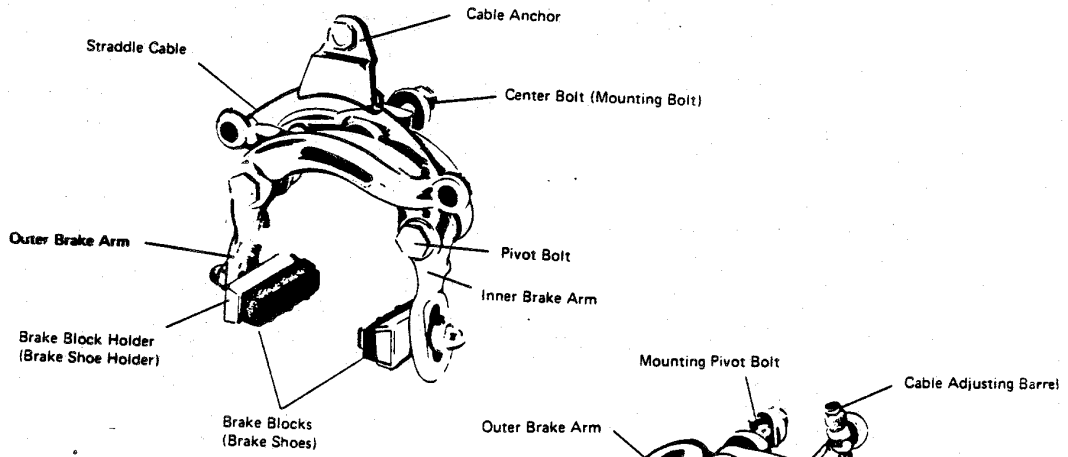

FIGURE 5. DRIVE SYSTEM





**Caliper Braking System**



**Center Pull Caliper Brake**

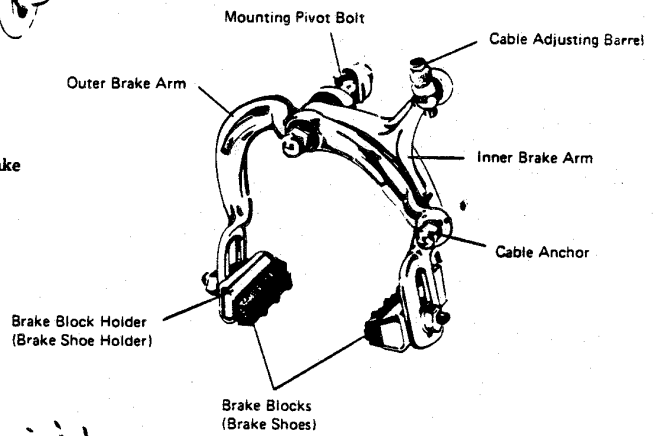

**Side Pull Caliper Brake**

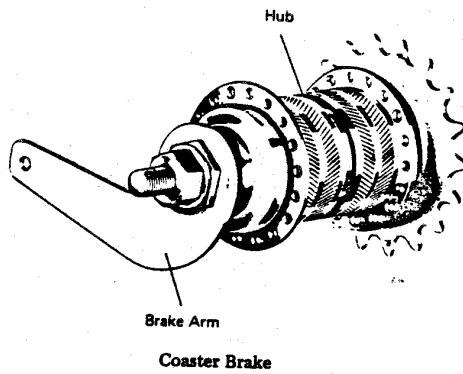

**Coaster Brake**

**FIGURE 6. BRAKE SYSTEM**