

Appendix 110
September 1993

**BABY WALKER INCIDENT
INVESTIGATIVE GUIDELINE**

I. INTRODUCTION

A. Background Information

The Consumer Product Safety Commission (CPSC) has long recognized the hazards associated with baby walkers. Efforts to address injuries associated with these products have included the publication of mandatory safety standards, participation in the development and revision of a voluntary standard, and dissemination of a variety of consumer information materials. A recent review of data on children's hazards through CPSC's Hazard Screening Project suggested baby walker injuries to be a potential area for further study or future project activities.

In 1992, CPSC was petitioned by the Consumer Federation of America (CFA), the American Academy of Pediatrics (AAP), the Washington State Chapter of the AAP, the National Safe Kids Campaign, and Consumers Union to ban baby walkers. The petitioners asserted that baby walkers have been a major source of childhood injury, and that the voluntary safety standard for walkers [developed through the American Society for Testing and Materials (ASTM)] and numerous consumer education efforts (by CPSC and others) have had little or no effect on the number of injuries each year. The petitioners also alleged that walkers caused adverse developmental effects on children.

The Commission voted to deny the petition in April 1993, stating that the record could not support the requested action. However, the staff was directed to develop a project for Commission consideration that would contain recommendations for an appropriate course of action to address the alleged hazards associated with baby walkers. The project was approved at mid-year review. This special study of walker-related injuries is a major part of the project.

Preliminary findings by CPSC staff indicated that the risk of walker-related injuries relative to the number of live births in the U.S. has remained virtually stable since 1984. The literature did not support a conclusion that walkers caused adverse developmental effects. Nevertheless, the CPSC estimates that there were about 27,000 walker-related injuries to children under 15 months of age treated in U.S. hospital emergency rooms in 1991. About 80 percent of these injuries involved falls down steps, stairs, or between levels. About one-third of these injuries could be classified as potentially serious, in that they included fractures, concussions, dislocations, amputations, burns, or internal injuries. In addition, the CPSC staff is aware of about one death per year involving baby walkers.

The goal of this special study is to more fully identify the circumstances involved in baby walker incidents. Information collected will be used to answer the following questions:

1) Can product modifications be developed to address the identified hazards?

2) What portion of the injuries would be addressed by these modifications?

Data collection will continue over a 12-month period. A sample of about 300-400 cases identified through the National Electronic Injury Surveillance System (NEISS) will be followed up by telephone investigations to obtain additional information about the incident. Incidents involving falls down steps or stairs, as well as other incidents for which additional detail is required, will be reassigned for on-site investigation. Analysis of the data is expected to be completed in the spring of FY 1995.

B. Product Description

Baby walkers are described by ASTM as "a mobile (or immobile) unit which enables a child to move forward or sideward while learning to walk." A baby walker generally consists of a fabric seat with leg openings mounted to a rigid plastic deck, often with a feeding tray.

The deck is attached to a base with wheels. Walkers generally can be folded for storage, and may have adjustable seat heights and a bouncing mechanism. Activity toys may be attached to the trays. Some walkers have wheel-lock mechanisms (see figure below).

Illustration of a Typical Baby Walker



C. Specific Items of Interest

Incidents involving falls down steps or stairs are of particular interest, in that they account for the majority of injuries. Information on the width of the doorway or stairway entrance, measured at the narrowest point where the walker would pass through, is critical to determining whether product modifications, such as increasing the diameter of the walker, will be effective in preventing these incidents. It is also critical to determine whether the walker complied with the 1986 ASTM voluntary standard or the 1989 revisions to the standard. Both included safety labeling requirements including warnings about use near stairs, steps, and thresholds. The 1989 revision requires a permanent stairs warning label on each product in a place which will be seen by the consumer when placing the child in the walker, "WARNING: Avoid serious injury. NEVER use near stairs." It is essential to report the age of the walker, as well as the presence, content, and location of warning labels. The manufacturer and model of the walker should be reported whenever available.

For the FY 93-94 special study, a systematic random sample of cases will be selected for follow-up telephone investigation from CPSC Headquarters. A portion of these cases (primarily stair-fall incidents) will be assigned for on-site investigation for further information. A copy of the completed telephone investigation questionnaire (see Attachment 1) will accompany all on-site reassignment messages. Where appropriate, field investigators should make corrections and additions to the information reported on the telephone questionnaire. However, on-site investigations provide invaluable additional descriptive information about the product, victim, and circumstances involved, and therefore should not be limited to the data elements requested on the telephone questionnaire.

D. Headquarters Contact(s)

Joyce McDonald - EPHA - 301-504-7331
Debra Ascone - EPHA - 301-504-7403

II. INSTRUCTIONS FOR COLLECTING SPECIFIC INFORMATION

A. Synopsis

Within the synopsis, report the specific hazard pattern involved, such as falling down a step or stairway, tipping over, contacting a hot surface or liquid, having a finger or limb entrapped or pinched, contacting sharp edges or points, or having the walker collapse. Report the age and sex of the child, type of injury, body part involved, and any lasting or permanent effects.

KEY WORDS: FALL, STEP, STAIR, TIP, BURN, ENTRAP,
PINCH, SHARP, COLLAPSE

B. Description of the Product

- It is important to find out the age of the walker. Determine whether the walker was purchased/received new or used, and the length of time the owner had possession of the product.
- If the walker was purchased or received other than new, report how the walker was obtained (e.g., yard sale, hand-me-down, consignment shop, etc.).
- Report the manufacturer and model of the walker.
- Report the presence, location, and exact wording of any warning labels on the walker and accompanying instructional literature. Describe any graphics present. If possible, document these warnings with photographs.
- Describe the shape of the base upon which the wheels were attached (e.g., round, rectangular, etc.), and report the number of wheels present. If possible, photograph the walker from front, side, and overhead views to illustrate the construction of the walker.
- Describe the general condition of the walker and any damaged or broken parts. State whether the damage was present before the incident or resulted from the incident.

- Describe any safety features present such as wheel-locking mechanisms.

C. Description of the Incident Environment

- Report the type of setting in which the incident occurred. For example, was the walker being used in the child's home, a daycare provider's residence, a daycare center, or some other location?
- Determine whether this was a single family home, a townhouse, an apartment building, a school, or some other type of building.
- Report the specific location in which the incident occurred. For example, did it occur in a kitchen, family room, stairway, or some other area? If the incident started in one room and ended in another, indicate which rooms or locations were involved. If it occurred on a stairway, specify the rooms at the head and the foot of the stairs.
- Specify the approximate time of day of the incident and approximately how many minutes the child was in the walker before the incident happened.
- Determine who was taking care of the child at the time of the incident (e.g., parent, relative, sitter, etc.).
- Did the caregiver see the incident occur? Did any one else witness the incident? Please specify.
- Determine who (other than the child) was in the same room or area at the time of the incident, and what they were doing when it occurred. If known, report about how far they were from the victim.
- Please describe what happened just before, during, and just after the incident.
- Describe any product features or perceived product failures that, in the opinion of the respondent, may have contributed to the incident.
- Describe the role of siblings or other children in the incident, if any.

- If the injury resulted from contact with a hot surface or liquid, describe the source of heat and how the child reached it.
- If the injury resulted from entrapment or pinching, please photograph or diagram the part of the walker involved, and obtain relevant dimensions of the entrapment area.

For incidents specifically involving a tip-over:

- Describe the type of floor or floor covering(s) under the walker throughout the sequence of the incident. If the floor was carpeted, describe the height and density of the pile. Please measure the height of the pile and photograph the carpet.
- If a threshold strip was present, report the material from which it was made (e.g., wood, stone, metal, etc.) and the dimensions of the threshold strip cross-section. Please photograph or provide drawing.

For incidents specifically involving falls down steps or stairs:

- Report the inside width (in inches) of the step or stairway opening. It is important to obtain the narrowest dimension of the opening at the level the walker passed through (close to the floor). Please photograph the opening.
- Describe the step or stair surface(s) and any differences in the surfaces throughout the sequence of events (e.g., top step wood, stairs carpeted, floor at bottom of stairs concrete). If carpet was present, describe the height and density of the pile. Please measure the height of the pile and photograph the carpet.
- Determine if there was a threshold strip on the floor at the top of the stairs. If so, report or describe the material it was made from (e.g., wood, stone, metal, etc.), and its cross-sectional dimensions. Please photograph or diagram.

- Report if there was a door, barrier, or gate at the top of the stairs at the time of the incident. Determine if the door, barrier, or gate is usually closed when the child is using the walker.
- If a gate was present, try to find out how it became opened (e.g., gate was left open or not fastened properly, child unfastened or pushed gate, etc.). Note if there were any problems with the gate installation. Please photograph.
- If no barrier or gate was present at the time of the incident, determine if one has been installed since then.
- If the walker had any safety features such as a wheel-locking mechanism, determine if they were in use at the time of the incident.
- Report the number of steps or stairs travelled by the walker, including the top step or stair.
- Try to find out the orientation of the walker as it started down the steps or stairs. Did it go down forward, backward, or in some other way? Did it remain upright, or did it tumble over during the fall. Was the walker upright or tipped over when it landed?
- Did the child remain in the walker throughout the incident or did the child fall out of the walker?

D. Description of the Injured Person

- Verify the age and sex of the injured child.
- Obtain the approximate height and weight of the child, if available.
- Describe the type of injury and the parts of the body that were involved. Because head injuries are of particular interest, provide as much detail as possible for such injuries (e.g., area involved, severity, symptoms, etc.).
- Describe the type of treatment received at the hospital, and state whether there appear to be any lasting or permanent effects due to the incident.

If the child was admitted for hospitalization, report the length of stay. If the child received any follow-up treatment after the hospital visit, please describe.

E. Product Usage/Exposure

In evaluating possible risks of injury, it is important to examine various elements of the hazard scenario in conjunction with information about the general use of the product. Please report:

- The age of the child when he or she first started using the walker.
- How often the walker was typically used, and how long the child was in the walker for each use. Did this pattern of use change over time? If, so please describe these changes.
- Whether the time spent in the walker was more or less than the time spent crawling.
- The rooms or locations in which the walker was most often used.
- Specific times of day or occasions when the walker was typically used (e.g., when parent was preparing meals).
- Safety precautions generally taken before the child was put in the walker as compared to safety precautions taken before the child was put on the floor (when not in the walker).
- Any functions of the walker that the caregiver considered to be particularly important or useful (e.g. kept the child happy/quiet, helped the child to get exercise, etc.). If safety is reported as an important walker function try to find out the caregiver's rationale.
- Products sometimes used in lieu of the walker (e.g., playpen, high chair, etc.).
- Previous incidents the victim or siblings may have experienced with this or other baby walkers. Describe such incident(s) and note the nature and extent of any injuries that may have resulted.

- Whether the child used the walker since the incident, or would be likely to use it in the future. If not, describe the reasons why (e.g., walker broken, caregiver considers the walker too dangerous, etc.)

F. Product Safety Standards

1. Mandatory Standards

Infant walkers are subject to the banning regulation under 16 CFR 1500.18(a)(6) of the Federal Hazardous Substances Act unless they meet the criteria described under 16 CFR 1500.86(a)(4). Under the 16 CFR 1500.86(a)(4) requirements, infant walkers must be designed to:

- prevent injury from any scissoring, shearing, or pinching when the frame or other components rotate;
- cover coil springs with spaces greater than 0.125 inches;
- guard any holes, slots, cracks greater than 0.125 inches;
- prevent incidental collapse;
- provide the name and address of the manufacturer, packer, distributor, or seller; and
- provide code mark on the article, package container, and on the invoice or shipping records.

In addition, walkers are also subject to the mandatory standards for small parts, 16 CFR 1501; the sharp point technical requirements, 16 CFR 1500.48; the sharp edge technical requirements, 16 CFR 1500.49; and the ban of excess lead-in-paint, 16 CFR 1303.

Hazards not covered by the mandatory regulations could be addressed under Section 15 of the Federal Hazardous Substances Act where appropriate.

2. Voluntary Standard

The ASTM voluntary standard, ASTM F977, Standard Consumer Safety Performance Specification for Infant Walkers, contains performance requirements addressing stability, structural integrity, and occupant retention; test methods; and labeling requirements.

The labeling requirements address instructional literature, product identification, and warnings and/or graphics on the product. The warnings on the walker are to be displayed so that they can be seen during some phase of assembly or product use (see Attachment 2). In general, the required warnings are:

- never leave the child unattended;
- never use near stairs, steps, or thresholds;
- make certain both feet of the child touch the floor; and
- avoid burn injuries, by keeping children away from ranges, radiators, space heaters, and fireplaces.

In an 1989 revision of the voluntary standard, an additional stair warning label was required to be placed on the walker in a place that will be seen by the consumer when placing a child in the walker. The stair warning states:

"WARNING: Avoid serious injury. NEVER use near stairs." The instructional literature is required to include an additional warning that the child "...should always be kept in view while in the walker."

**INSTRUCTIONS FOR PHOTOGRAPHING AND DIAGRAMMING THE
INCIDENT SCENE AND PRODUCT INVOLVED.**

- Please photograph the walker from front, side, and overhead views to illustrate the walker base (e.g., round, rectangular, etc.) and number of wheels.
- Photograph any warning labels and graphics on the walker to illustrate their location and content.
- Diagram the room or area in which the incident occurred to illustrate the path of the walker during the incident sequence. If the incident involved a fall down steps or stairs, diagram the step or stairway opening and provide the inside width (in inches) of the opening at the narrowest dimension (e.g., the inside edges of the door frame) close to the floor.
- Photograph the floor or floor covering(s) present under the walker during the incident.
- If a threshold strip was present in the incident location, photograph and provide a diagram of its cross-sectional dimensions.

**IV. INSTRUCTIONS FOR OBTAINING DOCUMENTS RELATED TO
THE INVESTIGATION**

- Obtain medical records, i.e., emergency room records or hospitalization records.
- If a death occurred, obtain all available medical records and other documentation from the medical examiner or coroner, police, and other knowledgeable parties.

November 4, 1993

Attachment 1

Task Number: _____

Date of Interview: ____ / ____ / ____
YY MM DD

BABY WALKER TELEPHONE QUESTIONNAIRE

1. **HELLO, ASK FOR PARENT (OR GUARDIAN) OF INJURED CHILD. SPECIFY RESPONDENT:**

- 1 Parent
- 2 Grandparent
- 3 Babysitter
- 7 Other; specify: _____

2. **READ:** I'm _____ calling for the U.S. Consumer Product Safety Commission. In cooperation with _____ hospital we're doing a study of baby walker-related injuries. The Commission is interested in learning more about these incidents, so that we can find ways to make walkers safer.

3a. **READ:** I understand that _____ was treated recently at the emergency room for an injury associated with a baby walker. Is that correct?
0 No

INTERVIEWER: END INTERVIEW IF THERE WAS NO INJURY OR INJURY INVOLVED A DIFFERENT PRODUCT; OTHERWISE CONTINUE.

BRIEFLY EXPLAIN REASON FOR NOT CONTINUING (DESCRIBE IF INJURY INVOLVED A DIFFERENT PRODUCT)

1 Yes (CONTINUE)

3b. Are you the person most familiar with the incident?
0 No (INTERVIEWER SEE INSTRUCTIONS BELOW)
1 Yes (CONTINUE)

INTERVIEWER: ASK TO SPEAK WITH PERSON MOST FAMILIAR WITH THE INCIDENT. IF RESPONDENT FOR THE INTERVIEW IS DIFFERENT FROM THAT SPECIFIED IN QUESTION 1, SPECIFY RESPONDENT

IF NECESSARY, SET UP CALL BACK TIME

CALL BACK TIME: _____ A.M. _____ P.M., DAY OF WEEK
PERSON TO CONTACT _____

IF THE PERSON WHO IS MOST FAMILIAR WITH THE INCIDENT IS SOMEONE OTHER THAN THE PARENT (E.G., A BABYSITTER) ASK IF YOU MAY CALL THIS PERSON TO GET INFORMATION AND CONTINUE INTERVIEW, OBTAINING AS MUCH INFORMATION AS POSSIBLE

- 1 No (CONTINUE)
- 2 Yes (CONTINUE)

Name _____ **Relationship To Child** _____

Telephone _____

8 Don't Know

9 Refused

3c. **READ:** Would you answer some questions so that we can find ways to make walkers safer? Of course, your answers will be kept completely confidential. No names are associated with the answers. This interview should take about 20 minutes to complete.

0 No (**ASK IF ANOTHER TIME WOULD BE BETTER AND SET UP A CALL BACK TIME:** _____ AM _____ PM, DAY OF WEEK _____)

1 Yes

4. Can you tell me as accurately as possible the day and month on which this incident occurred?

MONTH _____ DAY _____

IF RESPONSE IS NOT GIVEN IN A MONTH, DAY FORMAT SPECIFY RESPONSE BELOW:

8 Don't know

9 Refused

5. Are you the person who was taking care of _____ (child's name) when the incident happened?

0 No, (**SPECIFY PERSON:** _____)

RELATIONSHIP TO

CHILD: _____ (**SKIP TO 7**)

1 Yes (**CONTINUE**)

6. How well do you remember the incident? Do you remember it..(**READ CHOICES**)

0 Not very vividly

1 Somewhat vividly

2 Moderately vividly

3 Very vividly

4 Exceptionally vividly

INTERVIEWER: IF RESPONDENT HAS NOT INCLUDED WHAT WAS HAPPENING BEFORE THE INCIDENT ASK THEM TO DESCRIBE CIRCUMSTANCES LEADING UP TO THE INCIDENT.

INTERVIEWER: REVIEW THE MAIN POINTS OF THE SUMMARY WITH THE RESPONDENT. ASK IF YOU MISSED ANY IMPORTANT DETAILS. IN RETELLING THE RESPONSE, MAKE SURE THAT IT MAKES SENSE. ASK RESPONDENT TO EXPAND ON PARTS THAT ARE UNCLEAR.

READ: I'd like to ask you some more questions about the area where the incident happened, the walker, and about the injury. If you've already talked about an item that I ask you about, I may repeat it to make sure I haven't missed any important details.

8a. **READ:** First, I would like to ask a few questions about where the incident happened.

Where did the incident happen? For example, was it in the child's home, a daycare center, daycare provider's home or some other location?

- 1 Child's home
- 2 Daycare provider's home
- 3 Daycare center or nursery school
- 7 Other; specify: _____
- 8 Don't know
- 9 Refused

8b. Was this a single family home, a townhouse, an apartment building, a school, or some other place?

- 1 Single family home
- 2 Townhouse
- 3 Apartment building
- 4 School
- 7 Other; specify _____
- 8 Don't Know
- 9 Refused

8c. Is the place where the incident happened a... **(READ LIST)**

- 1 Single level home or place with no basement
- 2 Single level home or place with a basement
- 3 Multi-level home or place with no basement
- 4 Multi-level home or place with a basement
- 5 Other, specify _____
- 8 Don't Know
- 9 Refused

9a. **READ:** In what room(s) or areas did the incident occur? If the incident started in one room or area and ended in another, please tell me all rooms or areas involved. For example, the walker may have started in the kitchen and fallen down a flight of stairs into the basement.

ONLY ONE ROOM OR AREA INVOLVED, SELECT ROOM/AREA:

- 1 Kitchen
- 2 Bedroom
- 3 Family room, dining room, living room
- 4 Hallway or foyer
- 5 Stairway
- 6 Porch or deck
- 7-1 Other outdoor location;
specify:_____
- 7-2 Other; specify:_____
- 8 Don't know
- 9 Refused

MULTIPLE AREAS OR ROOMS INVOLVED:

BEGAN IN ROOM/AREA	PASSED THROUGH ROOMS/AREA(S)	END ROOM/AREA
_____	_____	_____

9b. Is the room or area where the incident happened most often where the walker is used? **(IF MULTIPLE ROOMS/AREAS INVOLVED, CLARIFY THAT THE ROOM WHERE THE INCIDENT STARTED IS THE ROOM IN QUESTION)**

0 No, **(SPECIFY USUAL ROOM(S) AND LOCATION(S))**

Room_____

Location_____

- 1 Yes
- 8 Don't Know
- 9 Refused

10a. Where was the caregiver in relation to _____ (child's name) when the incident happened?_____

- _____
- 8 Don't Know
 - 9 Refused

10b. Did anyone see the incident happen?

- 0 No
- 1 Yes, specify who saw the incident occur and describe where they were in relation to the child.

- _____
- _____
- 8 Don't know
 - 9 Refused

11. During the incident, did _____(child's name)..
(READ CHOICES BELOW, CIRCLE ALL THAT APPLY)
- 1 Fall down a step or stairway
 - 2 Tip-over while in the walker, without a fall down a step or stairway
 - 3 Contact a hot surface or liquid. Specify type (e.g., space heater, iron, coffee pot, etc.):_____
 - 4 Entrap or pinch a finger or limb. Specify area on walker that caused the injury:_____
 - 7 Other; specify:_____
 - 8 Don't know
 - 9 Refused

- TIP-OVERS CONTINUE
- STAIR FALLS SKIP TO Q 13a, PAGE 7
- ALL OTHERS SKIP TO Q 25a, PAGE 10

- 12a. **TIP-OVER INCIDENTS:** What do you think caused the walker to tip over? **(READ ITEMS, CIRCLE ALL THAT APPLY)**

- 1 Uneven floor surfaces; please describe:_____
- 2 Walker seemed unstable; describe:_____
- 7 Other; specify:_____
- 8 Don't know
- 9 Refused

- 12b. Did the walker tip over because of a threshold or doorsill on the floor? That is, was there a raised strip of wood, stone, metal, or other material present on the floor?

- 0 No
- 1 Yes; **ASK:** How high would you say this threshold or doorsill is? **(PROBE FOR A NUMERICAL ANSWER SUCH AS 1/4")**

INTERVIEWER: SKIP TO Q 25a, PAGE 10

13a. **STAIR-FALL INCIDENTS: READ:** Now I'd like you to think about the step or stairway opening where the incident happened.

How wide would you say the step or stairway opening is? To help you estimate, you might keep in mind that the width of a normal front door is about 3 feet. (**SPECIFY UNITS OF MEASUREMENT GIVEN, E.G., INCH, FEET**)

13b. Can you tell me how you came up with that number? In other words, what did you think of when you made your estimate? _____

8 Don't Know
9 Refused

14a. Was there a door at the top of the stairs?

0 No (**SKIP TO QUESTION Q 15a**)
1 Yes; **READ:** Describe the door, was it a swinging, a folding, or a regular door on hinges?

(CONTINUE)

8 Don't know (**SKIP TO Q 15a**)
9 Refused (**SKIP TO Q 15a**)

14b. Was the door open or closed just before the incident:

1 Open (**SKIP TO Q 15a**)
2 Closed (**CONTINUE**)
8 Don't Know (**SKIP TO Q 15a**)
9 Refused (**SKIP TO Q 15a**)

14c. How do you think the door was opened?

1 Door was improperly fastened or closed by an adult
2 Child unfastened or pushed door
3 Latch did not work right
7 Other; specify: _____
8 Don't know
9 Refused

15a. Was there a threshold or doorsill on the floor at the top of the step or stairs where the incident happened? That is, was there a raised strip of wood, stone, metal, or other material present on the floor at the top of the stairs?

0 No (**SKIP TO Q 16**)
1 Yes, describe:

(CONTINUE)

8 Don't know (**SKIP TO Q 16**)
9 Refused (**SKIP TO Q 16**)

15b. How high would you say this threshold or doorsill is?
(**PROBE FOR A NUMERICAL ANSWER SUCH AS 1/4"**)

16. At the time of the incident, was there a "gate" at the top of the stairs?

- 0 No (**SKIP TO Q 19**)
- 1 Yes (**CONTINUE**)
- 8 Don't know (**SKIP TO Q 19**)
- 9 Refused (**SKIP TO Q 19**)

17. Was the gate open or closed just before the incident?

- 1 Open (**SKIP TO Q 19**)
- 2 Closed (**CONTINUE**)
- 8 Don't know (**SKIP TO Q 19**)
- 9 Refused (**SKIP TO Q 19**)

18. How do you think the gate was opened?

- 1 Gate was improperly fastened or closed by an adult
- 2 Child unfastened or pushed gate
- 3 Latch did not work right
- 7 Other; specify: _____
- 8 Don't know
- 9 Refused

19. Had anything else been placed in the area to restrain (for example, a chair, or board) the child from the step or stairway?

- 0 No (**SKIP TO Q 21**)
- 1 Yes, describe restraining item and how it was placed in relation to the step or stairway. (**CONTINUE**)

-
- 8 Don't know (**SKIP TO Q 21**)
 - 9 Refused (**SKIP TO Q 21**)

20. How was _____ (child's name) able to get around this restraining item?

-
- 8 Don't know
 - 9 Refused

- 21a. Now I'd like you to think about the step or stairs where the incident happened.

Describe what the stairs are made of and any covering on the stairs, for example, wood stairs with carpet runner down the middle.

INTERVIEWER: IF THERE ARE MULTIPLE ITEMS ON THE SURFACE OF THE STAIRS, SPECIFY IN "OTHER" THE COMBINATIONS ON THE SURFACE

- 1 Wood
 - 2 Vinyl, linoleum
 - 3 Concrete
 - 4 Carpet
 - 7 Other; (SPECIFY OTHER SURFACE COVERING AND DESCRIBE MULTIPLE COMBINATIONS HERE, LISTING MATERIALS FROM THE CLOSEST TO THE FURTHEST FROM THE WALKER AND CHILD)
-

- 8 Don't know
- 9 Refused

- 21b. Was the surface or covering on the floor at the top of the stairs different from the other steps?
- 0 No
 - 1 Yes; please describe what surface and/or covering and how it is different from the other steps:
-

- 8 Don't know
- 9 Refused

22. On what type of surface, for example, wood floor, cement floor did the child land on when the walker and/or child stopped?
- 1 Wood
 - 2 Vinyl, linoleum
 - 3 Concrete
 - 4 Carpet

7 Other; (SPECIFY OTHER SURFACE COVERING AND DESCRIBE
MULTIPLE COMBINATIONS HERE, E.G., CARPET OVER CEMENT
FLOOR LISTING MATERIALS FROM THE CLOSEST TO THE
FURTHEST FROM THE WALKER AND CHILD)

- 8 Don't know
- 9 Refused

23. What direction was the walker going when it started down the steps--forward, backward, or some other way?

- 1 Forward
- 2 Backward
- 3 Sideways
- 7 Other; specify: _____
- 8 Don't know
- 9 Refused

24. While _____ (child's name) was in the walker, about how many steps did the walker go down?

ENTER NUMBER GIVEN _____*

7 Other; (IF CHILD CAME OUT OF WALKER AND CONTINUED OUT OF THE WALKER DOWN THE STAIRS, DESCRIBE)

- 88 Don't know
- 99 Refused

***ASK THE TOTAL NUMBER OF STAIRS IN STAIRWAY IF CHILD ONLY WENT DOWN PART OF THE STAIRWAY**

TOTAL _____

- 88 Don't Know
- 99 Refused

25a. **ALL HAZARD PATTERNS, CONTINUE HERE.** Next, I have some questions about _____(child's name) injuries.

Please describe the injury and parts of the body that were involved.

25b. How were these injuries treated at the hospital?

25c. After leaving the emergency room or hospital, did _____(child's name) see a doctor or receive any other medical treatment for this injury?

0 No

1 Yes, describe _____

8 Don't Know

9 Refused

25d. Has _____(child's name) fully recovered from (his/her) injuries?

0 No, describe (**ASK: DO YOU EXPECT HIM/HER TO HAVE ANY LASTING OR PERMANENT PHYSICAL PROBLEMS BECAUSE OF THE INCIDENT**)

- 1 Yes, fully recovered
- 8 Don't Know
- 9 Refused

25e. Had _____ (child's name) experienced previous injuries or incidents with this or other baby walkers?

- 0 No
- 1 Yes; please describe and specify when these occurred:

- 8 Don't know
- 9 Refused

26. Now, I'd like you to think about the walker involved in the incident.

In your opinion, was there anything wrong with the walker, like a product feature or some damage to the walker that may have helped to cause the incident?

0 No

1 Yes; please describe: _____

8 Don't know

9 Refused

27. **READ:** Walkers manufactured in recent years are supposed to have safety labels on them. Were there any labels on the walker?

0 No (**SKIP TO Q 29**)

1 Yes (**CONTINUE**)

8 Don't know (**SKIP TO Q 29**)

9 Refused (**SKIP TO Q 29**)

28a. Can you tell me what is written or drawn on the label and what it looked like?

0 No

1 Yes, describe _____

28b. Where were the labels located? (**READ ITEMS, CIRCLE ALL THAT APPLY**)

1 Seat, describe _____

2 Tray, describe _____

3 Base, describe _____

7 Other; specify: _____

8 Don't know

9 Refused

29. If you own the walker, how did you obtain the walker? That is, did you buy it new, buy it used, obtain it as a hand-me-down, or receive it as a gift or obtain it some other way?

Respondent does not own the walker,

specify owner _____ (**SKIP TO 31 a**)

1 Bought new

2 Bought used **ASK:** About how old do you think it is? _____

3 Obtained as hand-me-down **ASK:** About how old do you think it is? _____

4 Received as gift(new)

7 Other; specify:_____

8 Don't know

9 Refused

30. About how long have you (or the owner) had the walker? **IF**

LESS THAN ONE MONTH, SPECIFY AS ONE MONTH.

___ Months

___ Years

88 Don't know

99 Refused

31a. I have just a few more questions. These relate to the general use of the walker by _____ (child's name).

About how old was the child when (he/she) first started using the walker?

____ Months

88 Don't Know

99 Refused

31b. How old is (he/she) now? _____ Months

32a. When the incident happened, was this the first time _____ (child's name) used the walker?

0 No

1 Yes

8 Don't Know

9 Refused

32b. About how often did (he/she) use the walker?

1 Once a week or less

2 Several times a week

3 About once a day

4 More than once a day, estimate about how often _____

7 Other; specify: _____

8 Don't know

9 Refused

33. For each use, about how long did the child typically stay in the walker?

1 Less than 30 minutes

2 About a half an hour to an hour

3 Longer than one hour

7 Other; specify: _____

8 Don't know

9 Refused

34. Now for each question I'd like you to think about the walker's most useful functions.

Do you think it ... (READ EACH ITEM BELOW, CIRCLE ONE RESPONSE FOR EACH QUESTION)

	NO	YES	DK	REF
a. Keeps the child happy/quiet	0	1	8	9
b. Teaches the child to walk	0	1	8	9
c. Helps the child to get exercise	0	1	8	9
d. Gives the child freedom/independence	0	1	8	9
e. Provides a feeding place for the child	0	1	8	9
f. Keeps the child generally safe	0	1	8	9
g. Provides a place to put the child while caregiver is otherwise occupied	0	1	8	9

35. Since the incident, has the child used the walker again?
0 No, specify reason _____
1 Yes
8 Don't know
9 Refused

36. Do you still have the walker in your possession or know where it is located?
0 No
1 Yes, still have walker
2 Yes; walker is located at: _____

8 Don't Know
9 Refused

INTERVIEWER: FOR STAIR OR STEP FALLS CONTINUE, ALL OTHERS SKIP TO Q 39 UNLESS THE WALKER IS NOT IN RESPONDENT'S POSSESSION, THEN SKIP TO Q 41

37. **READ:** It is very important for us to know the width of the stairway opening. This will help us determine if walkers can be changed so they cannot go down stairs.

I would like you to measure, in inches, the narrowest inside width of the stairway opening, at a level near the floor. Would you be willing to do this while I wait?
0 No (CONTINUE)
1 Yes; specify width: _____ feet _____ inches (SKIP TO Q 39 UNLESS WALKER IS NOT IN RESPONDENT'S POSSESSION, THEN Q 41)

38. If this is not convenient to do now, may I call you back later for this information?

0 No (CONTINUE UNLESS WALKER IS NOT IN RESPONDENT'S POSSESSION, THEN Q 41)

1 Yes;

(SET UP CALL BACK TIME) TIME _____ A.M. _____ P.M. _____ DAY _____

(CONTINUE UNLESS WALKER IS NOT IN RESPONDENT'S POSSESSION, THEN Q 41)

39. **READ:** It is very important that we get detailed information about any safety labels on the walker to determine if the manufacturer is meeting the requirements.

INTERVIEWER CHOOSE APPROPRIATE PARAGRAPH:

If you remember seeing a label on the walker, I'd like you to look at the baby walker and tell me where the label is located and what is written or drawn on it. Would you be willing to do this while I wait?

If you don't remember seeing a label on the walker, could you look at the walker again. Sometimes manufacturers put labels under the tray or on the wheel base of the walker. I'd like you to look at the baby walker and tell me if there is a label located in either of these places or anywhere else and what is written or drawn on the label. Would you be willing to do this while I wait?

0 No (CONTINUE)

1 Yes: writing and any graphics on label (NOTE IF THERE IS ANY DAMAGE TO THE LABEL) _____

LOCATION OF LABEL _____

BRAND/MODEL OF WALKER _____ (SKIP TO 41)

40. If this is not convenient to do now, may I call you back later for this information? **(SET UP CALL BACK TIME)**
0 No **(CONTINUE)**
1 Yes; **(SET UP CALL BACK TIME)**_____
41. Thank you very much for your cooperation in this effort to make baby walkers safer. If I missed anything may I call you back?
0 No
1 Yes
8 Don't know



Designation: F 977 - 89

Standard Consumer Safety Performance Specification for Infant Walkers¹

This standard is issued under the fixed designation F 977; the number immediately following the designation indicates the year of original adoption or, in the case of revision, the year of last revision. A number in parentheses indicates the year of last reapproval. A superscript epsilon (ϵ) indicates an editorial change since the last revision or reapproval.

INTRODUCTION

This consumer safety performance specification addresses the walker accidents that were identified by the U.S. Consumer Product Safety Commission.

For the period between January 9, 1976 and March 26, 1982, 294 walker accident cases were reported to the National Electronic Injury Surveillance System (NEISS). Of these in-depth investigations conducted by the Commission, 201 involved injuries to children associated with the following: stability, seating systems, and folding mechanisms. In response to the accident analysis data developed by the Commission, this consumer safety performance specification attempts to minimize the above listed problems. This standard does not cover walkers that are blatantly misused, although warnings and safety instructions are displayed on and with each walker.

This consumer safety performance specification is written within the current state-of-the-art of walker technology. It is intended to be updated whenever substantive information becomes available that necessitates additional requirements or justifies the revision of existing requirements. It shall be reviewed and, if necessary, modified at least once every five years.

1. Scope

1.1 This consumer safety specification establishes performance requirements, test methods, and marking requirements to ensure safe use of the baby walker (see Section 2).

1.2 This consumer safety specification is intended to minimize accidents to children resulting from normal use and reasonably foreseeable misuse or abuse of walkers.

1.3 No walker produced after the approval date of this consumer safety specification shall, either by label or other means, indicate compliance with this specification unless it conforms to all requirements contained herein.

NOTE 1—This consumer safety specification is not intended to address accidents and injuries resulting from the interaction of other persons with the child in the walker or the accidents resulting from abuse and misuse by children over 15 months in age and walking.

NOTE 2—This consumer safety specification is intended to supersede the current existing standard 16 CFR Part 1500.86 (a) (4).²

1.4 The following precautionary caveat pertains only to the test method portion, Section 5, of this consumer safety specification: *This standard may involve hazardous materials, operations, and equipment. This standard does not purport to address all of the safety problems associated with its use. It is the responsibility of the user of this standard to establish appropriate safety and health practices and determine the applicability of regulatory limitations prior to use.*

2. Description of Term Specific to This Standard

2.1 *walker*—a mobile (or immobile) unit that enables a child to move forward or sideward while learning to walk, propelled by the child sitting or standing within the walker, and which is in the manufacturer's recommended use position. The word "walker" pertains to all types such as x-frame, circular, folding, adjustable, bouncer, unless specifically stated otherwise. The word "walker" also includes such common terminology as baby bouncers, walker-jumpers, baby walkers, bouncer-jumpers, etc. Examples of different style walkers can be seen in Fig. 1.

3. General Requirements

3.1 *Wood Parts*, shall be smoothly finished and free of splits, cracks, splinters, and other defects that could lead to failure. This applies before and after testing.

3.2 *Latching or Locking Mechanisms*—Any unit that folds in a collapsed closed position shall have a latching or locking device or other provision in the design that will prevent the unit from accidental folding when placed properly in the manufacturer's intended use position. Walkers with latching or locking devices preventing accidental folding shall be tested in accordance with 5.1. During and upon completion of this test, the unit shall remain locked and upright in its manufacturer's recommended use position.

3.3 *Holes*—Any shaped holes, slots, or cracks that are accessible to toes or fingers through the surface of any rigid material that admits a 0.210-in. (5.33-mm) diameter rod, shall also admit a 0.375-in. (9.52-mm) diameter rod. Holes that have a minimum dimension between 0.210 and 0.375 shall be permissible in any rigid material, providing the depth of penetration is no greater than the minimum dimension of the hole.

¹ This consumer safety performance specification is under the jurisdiction of ASTM Committee F-15 on Consumer Products and is the direct responsibility of Subcommittee F15.50 on Standards Development.

Current edition approved April 11, 1989. Published June 1989. Originally published as F 977 - 86. Last previous edition F 977 - 86¹.

² Available from U. S. Government Printing Office, N. Capital and H Streets, NW, Washington, DC 20401.

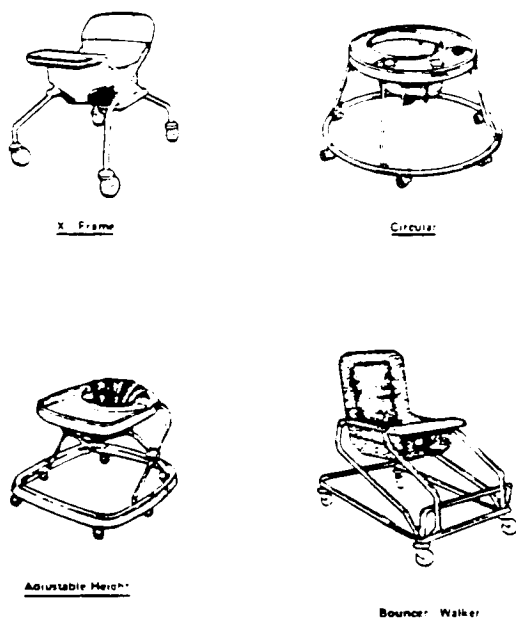

FIG. 1 Illustrations of Four Types of Baby Walkers

3.4 Walkers shall be constructed to minimize the potential for scissoring, shearing, or pinching injuries to the child while in the walker, during normal use, or reasonably foreseeable misuse. A minimum clearance of 0.375 in. (9.5 mm) shall be maintained between adjacent interacting and movable components that may cause such injuries.

3.5 *Coil Springs*—Any exposed coil spring, accessible to the occupant, having or generating a space between successive coils that is greater than 0.210 in. (3.2 mm) during the static load testing (4.2.2) shall be covered or otherwise designed to prevent injuries.

NOTE 3—All finishes and materials used in the construction of products covered under this ASTM Standard must be nonhazardous as defined by the Federal Hazardous Substances Act regulations as they may exist at the time the products are introduced into interstate commerce. Federal Regulations 16 CFR Section 1500.48 (sharp points), 16 CFR Section 1500.49 (sharp edges), 16 CFR Sections 1500.50 through 1500.53 (use and abuse), 16 CFR Part 1501 (small parts) and CFR Part 1303 (lead in paint) are in effect and are administered by the Consumer Product Safety Commission.² These Federal regulations itemized above are *not* part of this ASTM Standard. This information is offered to all parties so that they know these Federal regulations are *mandatory* and are outside the scope of this ASTM Standard.

4. Performance Requirements

4.1 *Stability*:

4.1.1 *Tipping Resistance Against An Immovable Object*—A Minimum Stability Index of 18 shall be required to tip over a walker either forwards or backwards when tested in accordance with 5.2.1.

4.1.2 *Occupant Leaning Over Edge*—A walker shall remain upright (not tip over) when weights are applied forward, and sideward, in accordance with 5.2.2.

4.2 *Structural Integrity*—All tests that cover static and dynamic loading, and support of the occupant, are to be performed on the same product, sequentially and without refurbishing or repositioning of adjustment, if any. At test

conclusion there shall be no failure of seams, breakage of materials, or changes in adjustments that could cause the unit not to support fully the child or create a hazardous condition as defined in Section 3. Maximum slippage of adjustable features, if any, is 1 in. (25.4 mm).

4.2.1 *Dynamic Load*—The occupant support member (seat) shall support a dynamic load when tested in accordance with 5.3.1.

4.2.2 *Static Load*—The walker shall not create a hazardous condition as defined in 3.4 when tested in accordance with 5.3.2.

4.2.3 *Occupant Retention*—The seat of the walker shall be designed so that (1) its lowest adjusted height is not greater than 8.5 in. (216 mm) above the floor when measured in accordance with 7.4, or (2) the leg openings would not permit the passage of a 6-in. weld cap (Fig. 2) as tested in accordance with 5.4.6.

5. Test Methods

5.1 *Latching or Locking Mechanisms* (3.2):

5.1.1 Erect the walker in accordance with the manufacturer's instructions and adjust to the highest and most upright recommended use position.

5.1.2 Position the walker so that the normal folding motion is not impeded.

5.1.3 Apply a force of 10 lbf (44.5 N) in the direction normally associated with folding the walker in accordance with manufacturer's instructions.

5.1.4 Perform this procedure for a total of five times within a 2-min period.

5.2 *Stability Test* (4.1):

5.2.1 *Tipping Resistance Against An Immovable Object* (4.1.1):

5.2.1.1 Establish a horizontal test plane with a piece of 1/2 in. high by 3/4 in. wide (13 by 19 mm) aluminum angle stop thereto. Its length shall be a minimum of 6 in. wider (152 mm) than the width of the walker being tested.

5.2.1.2 Place the walker on the horizontal test plane in the manufacturer's recommended use position. If the walker is adjustable, adjust to its highest use position. If the walker is reclining, place in its most upright position.

5.2.1.3 Affix a six-month CAMI Infant Dummy, Mark II to the walker so that its feet just touch the test plane and its

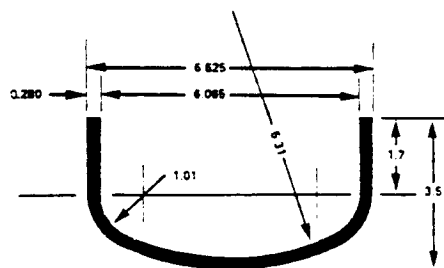

NOTE—Caps furnished to ANSI standards unless otherwise specified. Welding caps are formed from steel plate and are ellipsoidal in shape. The minor axis being equal to one half the major axis radii "R" and "r" closely approximate the actual semi-ellipsoidal shape. All dimensions in inches and are in accordance with ANSI B16.9.

FIG. 2 Nominal 6-in. Weld Cap Weight (Approximately) 6.4 lb

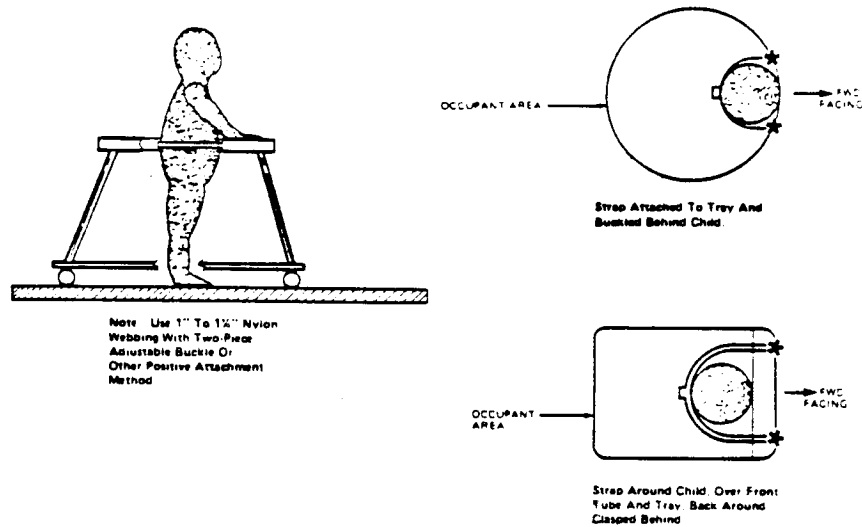

FIG. 3 Placement of CAMI Infant Dummy

abdomen is positioned firmly against the forward edge of the occupant area (see Fig. 3).

NOTE 4—It may be necessary to readjust the walker from its highest use position so that the dummy's feet do touch the floor.

5.2.1.4 Position the walker so that its two most forward wheels are touching but perpendicular to the aluminum stop. For walkers that have offset wheels, place wheels in the most disadvantageous position.

5.2.1.5 Pretension by gradually applying 3 lbf. (13 N) forward horizontal force at a level just below the CAMI II dummy's armpits in a direction perpendicular to the axis connecting the two most forward wheels and centered halfway between the wheels (see Fig. 4). Then increase the horizontal force until the walker tips over forward.

5.2.1.6 Record the distance pulled in inches after pretensioning and the maximum force exerted in pounds (including pretensioning). The sum of the distance pulled and maximum force exerted shall be considered the Stability Index.

5.2.1.7 Without adjusting seat height, place the CAMI Infant Dummy into the walker in a sitting position and adjust it so that it is tightly affixed against the rear of the occupant area. (See Fig. 5)

5.2.1.8 Position the walker so that its two most rearward wheels are touching but perpendicular to the aluminum stop. For walkers that have offset wheels, place wheels in the most disadvantageous position.

5.2.1.9 Pretension by gradually applying a 3-lbf horizontal force in a rearward direction perpendicular to the axis connecting the two most rear wheels and centered between the wheels. Apply the force at a level just below the CAMI II dummy's armpits. Then increase the force until the walker tips over. If the walker has a seat pad whose back is higher than the dummy's armpits, apply the horizontal force at the seat height as that of the Dummy's armpits.

5.2.1.10 Record the distance pulled in inches after

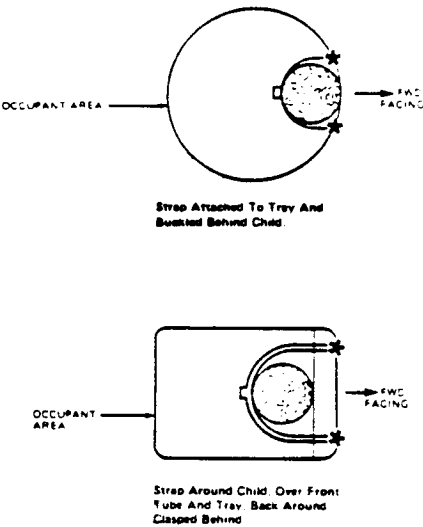

pretensioning and the maximum force exerted in pounds including pretensioning. The sum of the distance pulled and the maximum force exerted shall be considered the stability index.

5.2.2 Occupant Leaning Outward Over Edge of Walker (4.1.2):

5.2.2.1 Position walker in the manufacturer's recommended use position with all wheels on the floor (flat horizontal plane). For walkers that have offset wheels, place wheels in the most disadvantageous position. If the walker is adjustable, adjust to its highest use position.

5.2.2.2 Clamp a 1- by 1-in. (25- by 25-mm) rigid aluminum angle to the uppermost front and rear horizontal frame members of the walker in a direction perpendicular to the axis of the two most forward wheels and centered between the wheels. The length of the aluminum angle should be such that it extends forward at least 12 in. (305 mm) beyond the front edge of the occupant seating area (see Fig. 5).

5.2.2.3 Place a weight of 17 lb (7.7 kg) on the aluminum angle at a distance 1 in. (25.4 mm) less than one-half the difference between the maximum height of the child, 32 in. (813 mm), and the height of the walker at the top edge of the tray adjacent to the seating area (see Fig. 6).

5.2.2.4 Repeat the steps in 5.2.2.1, 5.2.2.2, and 5.2.2.3, except position the aluminum angle in a sideward direction perpendicular to the axis connecting the two most sideward wheels and centered halfway between the wheels. Be sure the aluminum angle extends at least 12 in. (305 mm) beyond the inside edge of the tray or horizontal frame member. Placement of the 17-lb (7.7-kg) to the side shall not cause the walker to tip over.

5.3 Structural Integrity (4.2):

5.3.1 Dynamic Load (4.2.1):

5.3.1.1 Position the walker in the manufacturer's recommended use position with all wheels on the floor (flat

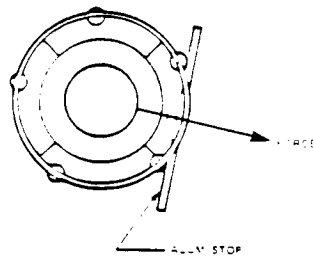

TIP RESISTANCE SETUP

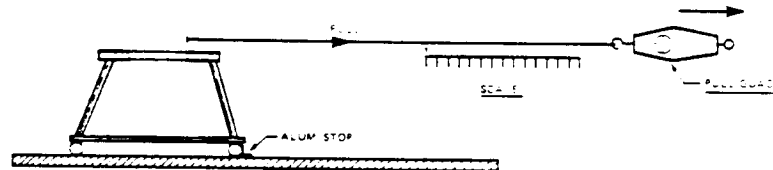

FIG. 4 Tip Resistance Setup

horizontal test plane). If adjustable, adjust to highest and most upright position.

5.3.1.2 Affix to the walker seat a 6- by 6-in. (150- by 150-mm) wood block nominally 1 in. thick. If the unit has a hammock type seat, use a standard 6-in. weld cap, convex surface down, as identified in Fig. 2, attached to the bottom of the test weight.

5.3.1.3 Drop a test weight of 33 lb (15.0 kg), with the weight of the weld cap included, at least a distance of 1 in. (25 mm) for one hundred times.

5.3.1.4 When testing a spring supported adjustable bouncer walker, test with the unit in the highest adjustment position and support the frame so that the dropping of the 33-lb (15.0-kg) weight does not cause the frame to bottom out artificially.

5.3.2 Static Load (4.2.2):

5.3.2.1 Perform the same test as in 5.3.1.1.

5.3.2.2 Center a weight of 90 lb (40.9 kg) for a period of 1 min on a 6- by 6-in. (150- by 150-mm) wood block nominally 1 in. thick affixed to the walker seat. If the unit has a hammock type seat, use a standard 6 in. weld cap, convex surface down, as identified in Fig. 2 instead of the specified wood block. Make weight allowance for the weld cap. If the natural action of a bouncer type walker will not allow the full application of 90 lb (40.9 kg) static load, then restrict the bouncer mechanism by any means possible so that the full static load can be applied to the seat or section of the walker occupied by the child.

5.3.2.3 Position the walker in the manufacturer's recommended use position with all wheels on the floor (flat horizontal test plane). If adjustable, adjust to the lowest use position.

5.3.2.4 Center a weight of 50 lb (22.7 kg) for a period of 1 min on a 6 by 6 in. (150 by 150 mm) wood block nominally 1 in. thick affixed to the walker seat. If the unit has a hammock type seat, use a standard 6 in. weld cap convex

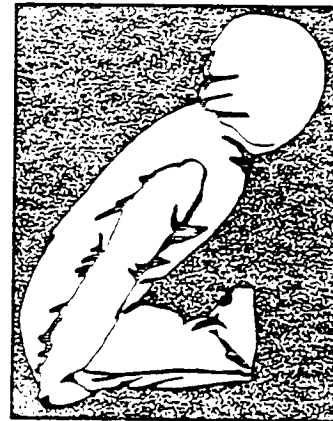

NOTE 1—This CAMI Infant Dummy was constructed in accordance with the Department of Transportation Specification dated April 29, 1975.

NOTE 2—Rowley Scher Repographics, 1216 K St. NW, Washington, DC 20005 (202) 628-6667

FIG. 5 CAMI Infant Dummy—Mark II

surface face down, as identified in Fig. 1 instead of the specified wood block. Make weight allowance for the weld cap. In this test DO NOT restrict the bouncer mechanism from folding or bottoming out.

5.3.3 Observe visually the action of all supporting, locking, and adjusting components to make sure that they do not create a hazardous condition as defined in 3.4.

5.4 Occupant Retention Testing (4.2.3):

5.4.1 Position the walker in the manufacturer's recommended use position with all wheels on the floor (flat horizontal test plane).

5.4.2 Adjust the walker or walker seat so that the seat is at its lowest safe and secure position above the floor or horizontal test plane.

5.4.3 Center a weight of 7.5 lb (3.4 kg) on the seat or a

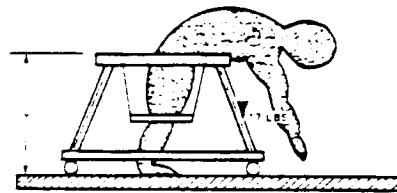
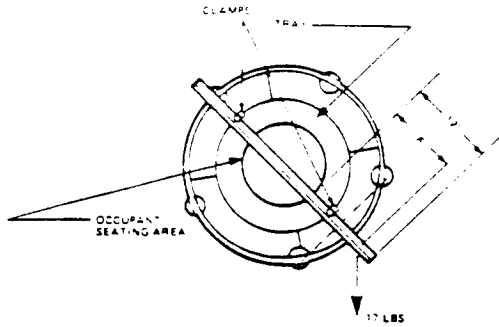

NOTE—X inches depends on height of walker, Y = height of walker tray or uppermost frame member

FIG. 6 Leaning Over Setup

by 6-in. (150- by 150-mm) wood block nominally 1 in. thick and affix it to the seat in such a manner that the weight will not move in relation to the seat. If the unit has a hammock type seat, use a standard 6-in. weld cap. Apply weld cap weight to the 7.5-lb (3.4-kg).

5.4.4 Measure the lowest point on the top surface of the seat from the floor or horizontal test plane.

5.4.5 For spring supported bouncer walkers, adjust the unit to the lowest recommended use position, place the minimum recommended weight in the seat, and measure the seat height as specified in 5.4.4.

5.4.6 If necessary, attempt to pass the outside diameter of a 6-in. weld cap through a leg opening.

6. Instructional Literature

6.1 Instructions will be provided with the walker in a leaflet form and shall be easy to read and understand. These instructions shall clearly include information of assembly, maintenance, cleaning, and use (including folding).

6.2 Warning Statements with The Instructional Literature

6.2.1 If the unit is designed with a restraint, the instructions must advise that the restraint system be used.

6.2.2 The instructions must advise that a **CHILD SHOULD NEVER BE LEFT UNATTENDED AND SHOULD ALWAYS BE KEPT IN VIEW WHILE IN WALKER.**

6.2.3 The instructions must indicate the manufacturer's recommended height, weight, or age, or combination

thereof, of the child for which the walker is intended. If the walker is not intended for use by a child who can already walk unassisted, the instructions shall so state this limitation.

6.2.4 The instructions must include the following statement: "Discontinue using the walker should it become damaged or broken."

7. Product Marking

7.1 Each walker shall have a permanent conspicuous label or marking attached to both the shipping container and the product that identifies the name and address (city, state, and zip code) of either manufacturer, distributor, or seller. A padding label required by law will not be considered permanent.

7.2 A code mark or other identification shall be provided on the walker and on either the package containing the walker or on the shipping container which will identify the date (month and year) of manufacturer and model number permitting future identification. A padding label required by law shall not be used for such identification.

7.2.1 The manufacturer shall change the model number whenever the walker undergoes a significant structural or design modification or a change that affects its conformance with this consumer safety performance specification.

7.3 *Warning Labels*—One or more conspicuous label(s) shall be on each product. The letters of the word "WARNINGS" shall be not less than 1/8 in. high (3.2 mm), and the remainder of the test shall be in letters not less than 3/32 in. high (2.4 mm). The warning label shall be of a contrasting color.

7.3.1 Language or combination of language and graphics shall be used to unambiguously convey the following warnings:

WARNINGS:

Never leave child unattended. Always keep child in view while in walker.

Never use near stairs, steps, thresholds. Check that surfaces are flat and free of objects that may cause tipping-over either indoors or outdoors.

To reduce chance of child slipping out of the seat, check that both feet of child touch the floor and never carry walker with child in it.

To avoid burn injuries, keep child away from ranges, radiators, space heaters, fireplaces, etc.

NOTE 3—The above mentioned label(s) shall be displayed so that it (they) can easily be seen during some phase of assembly or use of the product, or both.

7.4 *Stairs Warning*—A permanent stairs warning label shall be on each product in a place which will be seen by the consumer when placing child in walker. The letters of the word **WARNING** shall be not less than 1/8 in. high (3.2 mm) and the remainder of the text shall be in letters not less than 3/32 in. high (2.4 mm). The label shall be printed in a contrasting color.

7.4.1 Language or combination of language and graphics shall be used to unambiguously convey the following warning:

WARNING: Avoid serious injury. NEVER use near stairs.

The American Society for Testing and Materials takes no position respecting the validity of any patent rights asserted in connection with any item mentioned in this standard. Users of this standard are expressly advised that determination of the validity of any such patent rights, and the risk of infringement of such rights, are entirely their own responsibility.

This standard is subject to revision at any time by the responsible technical committee and must be reviewed every five years and if not revised, either reapproved or withdrawn. Your comments are invited either for revision of this standard or for additional standards and should be addressed to ASTM Headquarters. Your comments will receive careful consideration at a meeting of the responsible technical committee, which you may attend. If you feel that your comments have not received a fair hearing you should make your views known to the ASTM Committee on Standards, 1916 Race St., Philadelphia, PA 19103.

BABY WALKER SPECIAL STUDY
September 1993

TASK NO.: _____ INTERVIEWER ID: _____

HOSPITAL ID: _____

DATE OF ER VISIT: ____/____/____
 YY MM DD

AGE: _____ MONTHS

SEX: 1 MALE
 2 FEMALE

RECORD OF CALLS

<u>DATE</u> YY/MM/DD	<u>DAY OF</u> <u>WEEK</u>	<u>EASTERN TIME</u>	<u>RESULT</u>	<u>SUGGESTED</u> <u>CALL BACK TIME</u>
___/___/___	_____	___:___ AM/PM	_____	___:___ AM/PM
___/___/___	_____	___:___ AM/PM	_____	___:___ AM/PM
___/___/___	_____	___:___ AM/PM	_____	___:___ AM/PM
___/___/___	_____	___:___ AM/PM	_____	___:___ AM/PM
___/___/___	_____	___:___ AM/PM	_____	___:___ AM/PM
___/___/___	_____	___:___ AM/PM	_____	___:___ AM/PM
___/___/___	_____	___:___ AM/PM	_____	___:___ AM/PM
___/___/___	_____	___:___ AM/PM	_____	___:___ AM/PM
___/___/___	_____	___:___ AM/PM	_____	___:___ AM/PM
___/___/___	_____	___:___ AM/PM	_____	___:___ AM/PM
___/___/___	_____	___:___ AM/PM	_____	___:___ AM/PM
___/___/___	_____	___:___ AM/PM	_____	___:___ AM/PM
___/___/___	_____	___:___ AM/PM	_____	___:___ AM/PM
___/___/___	_____	___:___ AM/PM	_____	___:___ AM/PM
___/___/___	_____	___:___ AM/PM	_____	___:___ AM/PM
___/___/___	_____	___:___ AM/PM	_____	___:___ AM/PM

- RESULT CODES: C=COMPLETED
T=TERMINATED
R=REFUSAL
B=LANGUAGE BARRIER
W=WRONG NUMBER
N=NON-WORKING NUMBER
NA=NO ANSWER
LB=LINE BUSY
CB=CALL BACK
LM=LEFT MESSAGE

COMMENTS (ATTEMPTS TO FIND CORRECT PHONE NUMBER, REASONS FOR REFUSAL, ETC.): _____

