

MOCK UP EVALUATION CRITERIA

ROCKLEDGE I AND II CONSOLIDATION

Welcome to the Rockledge I/II Mockup

As you know, NIH is in the process of renovating and restacking two leased buildings located at 6701 and 6705 Rockledge Drive. Fourteen end user groups will occupy the space: National Heart Lung and Blood Institute (NHLBI), National Library of Medicine (NLM), Center for Scientific Review (CSR), and eleven subgroups of the Office of the Director (OD).

To evaluate the office and workstation furniture being considered for this consolidation, mockups have been established on the Rockledge Campus. We invite you to attend the mockup presentations from April 2, 2018 through April 27, 2018 and provide your feedback on the products offered.

The hardcopy survey provided in this handout offer you the opportunity to mark your scores while in the room. **For your scores to count, please input this information into the NIH online survey hosted at**

http://crtkl.qualtrics.com/jfe/form/SV_9nKnIFnQr7t5bRr

Survey instructions:

- Rate the elements in each furniture category using a scale of **1 (low) to 5 (high)**.
- Provide a **separate score for each manufacturer**.

Thank you for participating!

Casegoods (Office Furniture) Survey Card

Please rate the following elements using a scale of **1 (low) to 5 (high)**.

Provide a separate score for each manufacturer.

Category	Haworth	Herman Miller	Teknion
Construction: Quality of product line details	1 2 3 4 5 NA	1 2 3 4 5 NA	1 2 3 4 5 NA
Construction: Quality of glazed panel option(s)	1 2 3 4 5 NA	1 2 3 4 5 NA	1 2 3 4 5 NA
Flexibility: Overhead storage options	1 2 3 4 5 NA	1 2 3 4 5 NA	1 2 3 4 5 NA
Flexibility: Utilizes “kit of parts”	1 2 3 4 5 NA	1 2 3 4 5 NA	1 2 3 4 5 NA
Flexibility: Functionality of storage components	1 2 3 4 5 NA	1 2 3 4 5 NA	1 2 3 4 5 NA
Flexibility: Functionality of adjustable & movable components	1 2 3 4 5 NA	1 2 3 4 5 NA	1 2 3 4 5 NA
Technology: Power/data at the work surface	1 2 3 4 5 NA	1 2 3 4 5 NA	1 2 3 4 5 NA
Technology: Accessibility to outlets below work surface	1 2 3 4 5 NA	1 2 3 4 5 NA	1 2 3 4 5 NA
Wire Management: Ease of accessibility	1 2 3 4 5 NA	1 2 3 4 5 NA	1 2 3 4 5 NA
Wire Management: User-friendliness	1 2 3 4 5 NA	1 2 3 4 5 NA	1 2 3 4 5 NA

Systems Furniture (Workstation) Survey Card

Please rate the following elements using a scale of **1 (low) to 5 (high)**.
Provide a separate score for each manufacturer.

Category	Haworth	Herman Miller	Teknion
Construction: Quality of product line details	1 2 3 4 5 NA	1 2 3 4 5 NA	1 2 3 4 5 NA
Construction: Quality of glazed panel option(s)	1 2 3 4 5 NA	1 2 3 4 5 NA	1 2 3 4 5 NA
Flexibility: Overhead storage options	1 2 3 4 5 NA	1 2 3 4 5 NA	1 2 3 4 5 NA
Flexibility: Utilizes "kit of parts"	1 2 3 4 5 NA	1 2 3 4 5 NA	1 2 3 4 5 NA
Flexibility: Functionality of storage components	1 2 3 4 5 NA	1 2 3 4 5 NA	1 2 3 4 5 NA
Flexibility: Functionality of adjustable & movable components	1 2 3 4 5 NA	1 2 3 4 5 NA	1 2 3 4 5 NA
Technology: Power/data at the work surface	1 2 3 4 5 NA	1 2 3 4 5 NA	1 2 3 4 5 NA
Technology: Accessibility to outlets below work surface	1 2 3 4 5 NA	1 2 3 4 5 NA	1 2 3 4 5 NA
Wire Management: Ease of accessibility	1 2 3 4 5 NA	1 2 3 4 5 NA	1 2 3 4 5 NA
Wire Management: User-friendliness	1 2 3 4 5 NA	1 2 3 4 5 NA	1 2 3 4 5 NA

Task Seating Criteria

(OMB#: 0925-0642; Exp. Date: 05/31/2020)

The following two question sets involve rating ergonomic features of the task and executive chairs. Please reference the diagram below for descriptions of select ergonomic features.

Seat Height

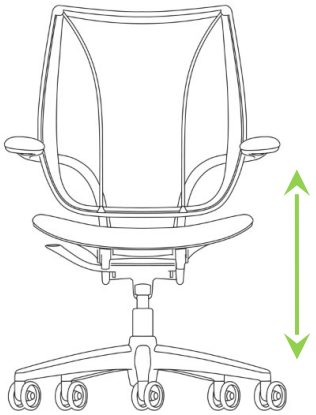

Seat Depth

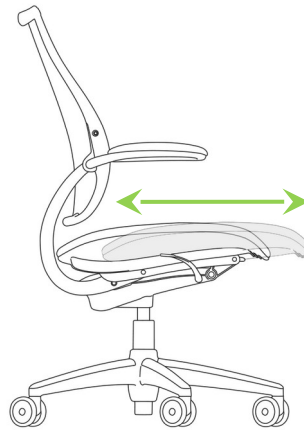

Lumbar Support

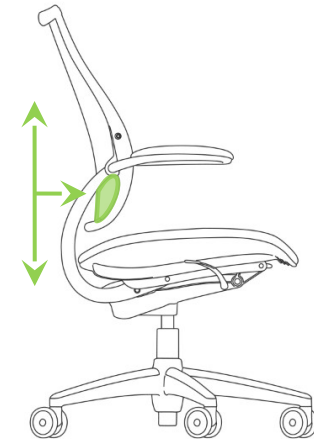

Tilt Function

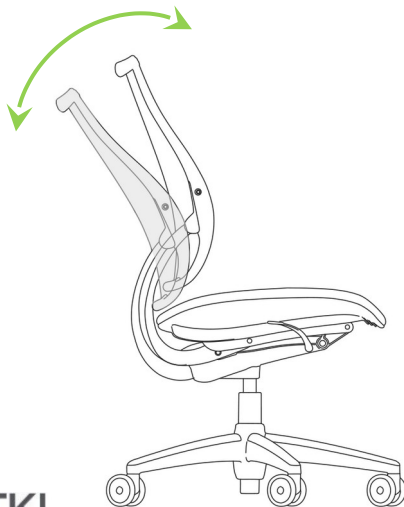

Arm Adjustments

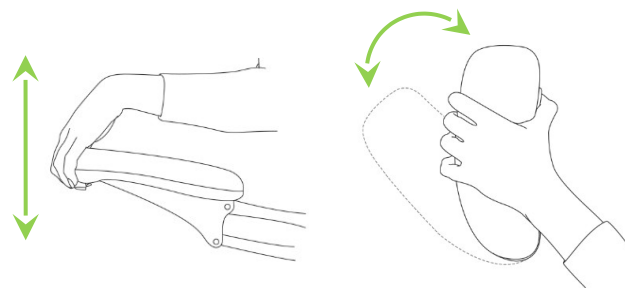

Task Seating – Standard Survey Card

Please rate the following elements using a scale of **1 (low)** to **5 (high)**.

Provide a separate score for each manufacturer.

Features	Haworth	Herman Miller	Humanscale	Teknion
Overall Construction	1 2 3 4 5 NA	1 2 3 4 5 NA	1 2 3 4 5 NA	1 2 3 4 5 NA
Ergonomic Design	1 2 3 4 5 NA	1 2 3 4 5 NA	1 2 3 4 5 NA	1 2 3 4 5 NA
Seat Height Adjustment	1 2 3 4 5 NA	1 2 3 4 5 NA	1 2 3 4 5 NA	1 2 3 4 5 NA
Seat Depth Adjustment	1 2 3 4 5 NA	1 2 3 4 5 NA	1 2 3 4 5 NA	1 2 3 4 5 NA
Lumbar Support	1 2 3 4 5 NA	1 2 3 4 5 NA	1 2 3 4 5 NA	1 2 3 4 5 NA
Tilt Function	1 2 3 4 5 NA	1 2 3 4 5 NA	1 2 3 4 5 NA	1 2 3 4 5 NA
Arm Style	1 2 3 4 5 NA	1 2 3 4 5 NA	1 2 3 4 5 NA	1 2 3 4 5 NA
Arm Adjustment	1 2 3 4 5 NA	1 2 3 4 5 NA	1 2 3 4 5 NA	1 2 3 4 5 NA
Base/Wheels	1 2 3 4 5 NA	1 2 3 4 5 NA	1 2 3 4 5 NA	1 2 3 4 5 NA
180 degree rotation	1 2 3 4 5 NA	1 2 3 4 5 NA	1 2 3 4 5 NA	1 2 3 4 5 NA

Task Seating – Executive Survey Card

Please rate the following elements using a scale of **1 (low) to 5 (high)**.

Provide a separate score for each manufacturer.

Features	Haworth	Herman Miller	Humanscale	Teknion
Overall Construction	1 2 3 4 5 NA	1 2 3 4 5 NA	1 2 3 4 5 NA	1 2 3 4 5 NA
Ergonomic Design	1 2 3 4 5 NA	1 2 3 4 5 NA	1 2 3 4 5 NA	1 2 3 4 5 NA
Seat Height Adjustment	1 2 3 4 5 NA	1 2 3 4 5 NA	1 2 3 4 5 NA	1 2 3 4 5 NA
Seat Depth Adjustment	1 2 3 4 5 NA	1 2 3 4 5 NA	1 2 3 4 5 NA	1 2 3 4 5 NA
Lumbar Support	1 2 3 4 5 NA	1 2 3 4 5 NA	1 2 3 4 5 NA	1 2 3 4 5 NA
Tilt Function	1 2 3 4 5 NA	1 2 3 4 5 NA	1 2 3 4 5 NA	1 2 3 4 5 NA
Arm Style	1 2 3 4 5 NA	1 2 3 4 5 NA	1 2 3 4 5 NA	1 2 3 4 5 NA
Arm Adjustment	1 2 3 4 5 NA	1 2 3 4 5 NA	1 2 3 4 5 NA	1 2 3 4 5 NA
Base/Wheels	1 2 3 4 5 NA	1 2 3 4 5 NA	1 2 3 4 5 NA	1 2 3 4 5 NA
180 degree rotation	1 2 3 4 5 NA	1 2 3 4 5 NA	1 2 3 4 5 NA	1 2 3 4 5 NA

Accessories Survey Card

(OMB#: 0925-0642; Exp. Date: 05/31/2020)

Please rate the following elements using a scale of **1 (low) to 5 (high)**.
Provide a separate score for each manufacturer.

Category	Haworth	Herman Miller	Humanscale	Teknion
Task Light	1 2 3 4 5 NA	1 2 3 4 5 NA	1 2 3 4 5 NA	1 2 3 4 5 NA
Monitor Arm	1 2 3 4 5 NA	1 2 3 4 5 NA	1 2 3 4 5 NA	1 2 3 4 5 NA
Keyboard Tray	1 2 3 4 5 NA	1 2 3 4 5 NA	1 2 3 4 5 NA	1 2 3 4 5 NA
Sit-Stand Desk	1 2 3 4 5 NA	1 2 3 4 5 NA	1 2 3 4 5 NA	1 2 3 4 5 NA
Guest Chair	1 2 3 4 5 NA	1 2 3 4 5 NA	1 2 3 4 5 NA	1 2 3 4 5 NA
	1 2 3 4 5 NA	1 2 3 4 5 NA	1 2 3 4 5 NA	1 2 3 4 5 NA
	1 2 3 4 5 NA	1 2 3 4 5 NA	1 2 3 4 5 NA	1 2 3 4 5 NA

NOTES:

* Task Light required to meet LEED requirements

** Additional options available for some accessories. Add relevant comments in notes portion.

- ***Burden Disclosure***
- Public reporting burden for this collection of information is estimated to average 5 minutes or less per response including the time for reviewing instructions. An agency may not conduct or sponsor, and a person is not required to respond to, a collection of information unless it displays a currently valid OMB control number. Send comments regarding this burden estimate or any other aspect of this collection of information, including suggestions for reducing this burden, to NIH Project Clearance Branch, 6705 Rockledge Drive, MSC 7974, Bethesda, MD 20892-7974, ATTN: PRA. OMB#0925-0642. Do not return the completed form to this address.