



Financial Crimes Enforcement Network (FinCEN)

FinCEN Suspicious Activity Report (FinCEN SAR) Electronic Filing Requirements

XML Schema 2.0

User Guide

DEPARTMENT OF THE TREASURY
FINANCIAL CRIMES ENFORCEMENT NETWORK (FINCEN)

0. Revision History

Version Number	Date	Change Description
1.0	01/26/2018	Initial version
1.1	06/15/2018	<p>3.2 Batch Validation (Form & Fit) Overview</p> <ul style="list-style-type: none"> • Added the following bullet to the list of general schema requirements that all XML batch files must adhere to: <ul style="list-style-type: none"> ○ Element values must not include leading and/or trailing spaces. ○ Element values must not include non-printable characters, such as carriage returns, line feeds, and tabs. ○ Element values must not contain duplicate entries within a single activity unless expressly permitted (<i>for example, a Subject party type may contain one legal name and up to 99 alternate names; therefore, if more than one legal name is recorded for the Subject, the batch file will fail validation and will not be accepted</i>). <p>4. FinCEN SAR XML Element Requirements</p> <ul style="list-style-type: none"> • <u>AssetSubtypeID</u> <ul style="list-style-type: none"> ○ Added the following rejection criteria to the Remarks: "The element contains a value that has already been recorded for the Activity." • <u>ActivityNarrativeSequenceNumber</u> <ul style="list-style-type: none"> ○ Added the following rejection criteria to the Remarks: "The element contains a value that has already been recorded for the Activity." • <u>OrganizationSubtypeID</u> <ul style="list-style-type: none"> ○ Added the following rejection criteria to the Remarks: "The element contains a value that has already been recorded for the Activity." • <u>SuspiciousActivitySubtypeID</u> <ul style="list-style-type: none"> ○ Added the following rejection criteria to the Remarks: "The element contains a value that has already been recorded for the Activity." • <u>PartyName</u> <ul style="list-style-type: none"> ○ Added the following rejection criteria to the Remarks: "More than one legal name is recorded for a party within a single FinCEN SAR Activity." • <u>PartyIdentification</u> <ul style="list-style-type: none"> ○ Added the following rejection criteria to the Remarks: "More than one identification (other than the Form of ID for the Subject) of the same type is recorded for a party within a single FinCEN SAR Activity." • <u>FormTypeCode</u> <ul style="list-style-type: none"> ○ Modified Value Restrictions and Example to correctly display the expected value of "SARX" rather than "FinCEN SARX". • <u>CyberEventIndicatorsTypeCode</u> <ul style="list-style-type: none"> ○ Modified the Value Restrictions by changing the "Other" cyber event indicator type code from "11" to "999". NOTE: This change has also been applied to the EFL_SARXBatchSchema.xsd schema. • <u>ElectronicAddressText</u> <ul style="list-style-type: none"> ○ Modified the Value Restrictions to specify that E-mail addresses should be 50 characters or less while Website (URL) addresses can be up to 517 characters and must contain at least one period. • <u>OrganizationTypeID</u>

		<ul style="list-style-type: none"> ○ Modified the Value Restrictions by changing the "Other" organization type code from "99" to "999". This is consistent with the current XML schema. • <u>OtherIssuerStateText</u> <ul style="list-style-type: none"> ○ Modified the Element Restrictions to include a third bullet that instructs the filer to record the element when "The identification type is Other and the identification was not issued by a national government." In the event that the "Other" identification recorded is a type of national government ID, such as a military ID, then the OtherIssuerStateText should not be recorded; instead, the OtherIssuerCountryText should be recorded identifying the Country where the ID was issued by (or in) associated with the subject. • <u>PartyIdentificationNumberText</u> <ul style="list-style-type: none"> ○ Modified the Value Restrictions to include a statement that "asterisks within the identification number are accepted for the subject's form of identification." This was added to accept Washington State Driver's License numbers containing asterisks. ○ Modified the Description of the Financial Institution Where Activity Occurred for bullet "55. Filing institution identification" to "55. Financial institution identification". ○ Modified the Value Restrictions to include the following for the Transmitter (35) TCC: TCC = 8 characters "equal to "TBSATEST" (when submitting in the BSA E-Filing User Test System) or "PBSA8180" (when submitting in the BSA E-Filing Production System)". • <u>PartyIdentificationTypeCode</u> <ul style="list-style-type: none"> ○ Modified the Description of the Financial Institution Where Activity Occurred (bullet "55. Filing institution identification" to "55. Financial institution identification". • <u>PhoneNumberText</u> <ul style="list-style-type: none"> ○ Modified the Value Restrictions to include the following NOTE for the Transmitter (35): "NOTE: This number must be the same for all FinCEN SARs in the batch file." • <u>RawPartyFullName</u> <ul style="list-style-type: none"> ○ Modified the Element Restrictions to include the following NOTE for the Transmitter Contact (37): "(NOTE: The value recorded must be the name of the individual to be contacted on issues involving the batch file. This entry must be the same for all FinCEN SARs in the batch file.)" ○ Modified the Value Restrictions to include the following note for the Contact Office (8): "(NOTE: This value recorded must be the title of the administrative office (such as Compliance Office) that should be contacted for additional information about the FinCEN SAR.)" • <u>SuspiciousActivity</u> <ul style="list-style-type: none"> ○ Modified the Description by changing the maxOccurs associated with the SuspiciousActivityClassification sub-element from "1" to "99". • Branch Address Elements: <ul style="list-style-type: none"> ○ <u>Party</u> <ul style="list-style-type: none"> ▪ Modified the Element Description by changing the Address minOccurs from "0" to "1". ○ <u>Address</u>
--	--	---

		<ul style="list-style-type: none"> ▪ Modified the Element Description by changing the minOccurs from "1" to "0" for the following: RawCityText, RawStreetAddress1Text, and RawZIPCode. ○ <u>RawCityText</u> <ul style="list-style-type: none"> ▪ Modified the Element Restrictions from "Required. This element must be recorded if the parent element is recorded" to "Record this element for the Branch (46) where activity occurred party type when the city associated with the branch address is known; otherwise, do not record this element." ▪ Removed the following from the Remarks: "The batch submission will be accepted with warnings if any of the following conditions are true: The element is not recorded or does not contain a value." ○ <u>RawStreetAddress1Text</u> <ul style="list-style-type: none"> ▪ Modified the Element Restrictions from "Required. This element must be recorded if the parent element is recorded" to "Record this element for the Branch (46) where activity occurred party type when the street address associated with the branch address is known; otherwise, do not record this element." ▪ Removed the following from the Remarks: "The batch submission will be accepted with warnings if any of the following conditions are true: The element is not recorded or does not contain a value." ○ <u>RawZIPCode</u> <ul style="list-style-type: none"> ▪ Modified the Element Restrictions from "Required. This element must be recorded if the parent element is recorded" to "Record this element for the Branch (46) where activity occurred party type when the ZIP/Postal Code associated with the branch address is known; otherwise, do not record this element." ▪ Removed the following from the Remarks: "The batch submission will be accepted with warnings if any of the following conditions are true: The element is not recorded or does not contain a value." <p>6. FinCEN SAR XML Acknowledgement Format</p> <ul style="list-style-type: none"> • Added the following schema reference to the introductory paragraph: "Please visit https://www.fincen.gov/sites/default/files/schema/base/EFL_BatchAcknowledgementSchema.xsd to access the FinCEN XML 2.0 batch acknowledgement schema file." • Added a more detailed diagram to section 6.1 XML File Structure. • Updated the Acknowledgement file examples. <p>Attachment A – Error Descriptions</p> <ul style="list-style-type: none"> • Updated Fatal error code A19 description from "Unknown file error. Please contact the BSA E-Filing Help Desk for assistance" to "Schema validation failure. The XML file does not conform to the defined schema located at https://www.fincen.gov/base/EFL_SARXBatchSchema.xsd." • Removed Warning error code B8 "The element contains a value that is not valid for the associated party type" (misc.) because it is not associated with any particular field on the FinCEN SAR.
--	--	---

		<ul style="list-style-type: none"> • Updated Fatal error code B9 as follows: "The element is not recorded or does not contain a value." This is due to the fact that error code B7 is triggered if the element is recorded but with no value (i.e. the value is null). • Modified Warning error code C25 to include the following: ...and the county code is US, CA, MX, "or a U.S. Territory." • Removed Warning error code D42 "The element is not recorded or does not contain a value" for Item 70. Branch ID Number. • Removed Fatal error codes G17 "The element is recorded but without a value (i.e. the value is null)" and G18 "The element contains a valid that is not a valid code" because they are duplicates of G14 and G15, which have been updated to be associated with both Transmitter TIN Type and Transmitter Control Code (TCC) Type. • Removed the following Warning error codes associated with the Branch Address sub-elements: <ul style="list-style-type: none"> ○ D40 – The element is not recorded or does not contain a value (RawStreetAddress1Text/69. Street) ○ D43 – The element is not recorded or does not contain a value (RawCityText/71. City) ○ D48 – The element is not recorded or does not contain a value (RawZIPCode/73. ZIP/Postal Code) • Modified Warning error code D46 as follows: "The element is not recorded or does not contain a value when the country is US, CA, MX, or a U.S. Territory. <p>Attachment C – Electronic Filing Institutions</p> <ul style="list-style-type: none"> • Modified the descriptions associated with 4. Continuing Reports as follows: <ul style="list-style-type: none"> ○ Change "Continuing reports should be filed at least every 90-days..." to "Continuing reports should be filed on successive 90-day review periods..." ○ Added the following directly after the above: until the suspicious activity ceases, "but may be filed more frequently if circumstances warrant that. Filers have up to 30 days following the end of a review period to file the continuing report for a total of 120 days of review and filing deadline." • Modified the description associated with 7. Addresses as follows: <ul style="list-style-type: none"> ○ Removed the following reference: "U.S. State and Territory codes must conform to the codes used by the United States Postal Service as documented in ISO 3166-2:US." • Replaced the following 9.6.2 Item Instructions associated with Item 29 (Amount involved in this report) with what is currently recorded: "Item *29 Amount involved in this report: Enter the total dollar amount involved in the suspicious activity for the time period of this report. If the amount is unknown, leave this item blank and check box 29a "Amount unknown." Explain why the dollar amount is unknown in Part V. If some dollar amounts are known while others are unknown, enter the total of all known amounts and explain the unknown amounts in Part V. If there is no amount involved in the suspicious activity, check box 29b "No amount involved." If the FinCEN SAR is a continuing report with box 1c "Continuing activity report" checked, enter only the amount involved for the time period covered by this FinCEN SAR. Do not include amounts from prior FinCEN SARs in Item 29. See General Instruction 9 for information on entering amounts."
--	--	---

Contents

0. Revision History..... iii

Contentsvii

1. Introduction 1

2. FinCEN SAR XML Schema Overview..... 1

 2.1. File Organization 1

 2.1.1. XML declaration (prolog)..... 1

 2.1.2. EFilingBatchXML 1

 2.1.3. Activity 2

 2.1.4. Party..... 3

 2.1.5. SuspiciousActivity..... 4

3. FinCEN SAR XML Batch Reporting Requirements 5

 3.1. Element Definition Overview..... 5

 3.2. Batch Validation (Form & Fit) Overview 6

4. FinCEN SAR XML Element Requirements 6

 4.1. XML declaration/prolog 6

 4.2. EFilingBatchXML Elements 6

 4.3. Activity Elements 8

 4.4. ActivityAssociation Elements 10

 4.5. ActivitySupportDocument Elements..... 13

 4.6. Party Elements..... 14

 4.6.1. PartyName Elements..... 27

 4.6.2. Address Elements..... 35

 4.6.3. PhoneNumber Elements 42

 4.6.4. PartyIdentification Elements..... 45

 4.6.5. OrganizationClassificationTypeSubtype Elements 52

 4.6.6. PartyOccupationBusiness Elements..... 57

 4.6.7. ElectronicAddress Elements..... 58

 4.6.8. PartyAssociation Elements 60

 4.6.9. PartyAccountAssociation Elements 77

 4.7. SuspiciousActivity Elements 84

 4.7.1. SuspiciousActivityClassification Elements..... 87

 4.8. ActivityIPAddress Elements..... 93

 4.9. CyberEventIndicators Elements..... 95

 4.10. Assets Elements 98

 4.11. AssetsAttribute Elements..... 101

4.12.	ActivityNarrativeInformation Elements.....	103
5.	Party Elements by Party Type.....	106
5.1.	Transmitter Party Record Example.....	108
5.2.	Transmitter Contact Party Record Example.....	109
5.3.	Filing Institution Party Record Example.....	109
5.4.	Designated Contact Office Party Record Example.....	110
5.5.	Law Enforcement Agency Party Record Example.....	110
5.6.	Law Enforcement Name Party Record Example.....	110
5.7.	Financial Institution Where Activity Occurred Party Record Example.....	110
5.8.	Branch Where Activity Occurred Party Record Example.....	111
5.9.	Subject Party Record Example.....	112
5.10.	Financial Institution Where Account is Held Party Record Example.....	113
6.	FinCEN SAR XML Acknowledgement Format.....	114
6.1.	XML File Structure.....	114
6.1.1.	XML declaration/prolog.....	114
6.1.2.	EFilingBatchXML.....	114
6.1.3.	EFilingSubmissionXML.....	115
6.1.4.	EFilingActivityXML.....	115
6.1.5.	EFilingActivityErrorXML.....	116
6.2.	Acknowledgement XML Example.....	118
7.	Attachment A – Error Descriptions.....	119
7.1.	Miscellaneous Errors.....	119
7.2.	Document Errors.....	120
7.3.	Subject Information Errors.....	125
7.4.	Financial Institution & Branch Where Activity Occurred Errors.....	128
7.5.	Filing Institution Errors.....	131
7.6.	Attachment & Narrative Errors.....	133
7.7.	Transmitter Errors.....	134
7.8.	Transmitter Contact Errors.....	135
8.	Attachment B – Error Correction Instructions.....	136
9.	Attachment C – Electronic XML Filing Instructions.....	138
9.1.	Confidentiality of FinCEN SARs:.....	138
9.2.	FinCEN SAR Sharing:.....	138
9.3.	Prohibition on Disclosures by Financial Institutions:.....	138
9.4.	Prohibition on Disclosures by Government Authorities:.....	139
9.5.	FinCEN SAR Filing Instructions:.....	139

9.6.	FinCEN SAR Electronic Filing Instructions.....	141
9.6.1.	General Instructions:.....	141
9.6.2.	Item Instructions:.....	146
10.	Attachment D – Secure Data Transfer Mode Filers	169
11.	Attachment E – Supporting Documentation (Attachments)	170

1. Introduction

The FinCEN Suspicious Activity Report (FinCEN SAR) XML Schema 2.0 User Guide outlines the business and validation rules to support the electronic batch transmission of the FinCEN SAR. Electronic filing of this report will be through the Bank Secrecy Act (BSA) E-Filing System operated by the Financial Crimes Enforcement Network (FinCEN). BSA E-Filing users who intend to file the FinCEN SAR batch XML should be familiar with FinCEN regulations, Extensible Markup Language (XML) and the FinCEN XML schemas. For more information, please go to bsae filing.fincen.treas.gov.

2. FinCEN SAR XML Schema Overview

Before you begin submitting your BSA data to FinCEN's BSA E-Filing System (bsae filing.fincen.treas.gov) via XML batch, you must first review the required schemas to assist you with constructing and testing your XML batch file before submitted to FinCEN for processing. These schemas define the requirements by which the FinCEN SAR XML batch file must be constructed, such as which elements are required and which are optional, what are the appropriate values you may enter for certain elements, and what sequence the elements should appear in when building the batch. Please visit https://www.fincen.gov/sites/default/files/schema/base/EFL_FinCEN_SARXBatchSchema.xsd to access the FinCEN XML 2.0 batch schema file.

2.1. File Organization

This section describes the general formatting requirements for FinCEN SAR XML batch reporting. The diagrams that follow provide a visual representation of the XML batch file layout from a high level perspective.

2.1.1. XML declaration (prolog)

The XML declaration specifies the XML version and character encoding used in the file. It must appear on the first line of the file.

2.1.2. EFilingBatchXML

This is the root element and serves as the container for all FinCEN SAR documents recorded in the batch. It must be the first element recorded in the file.

The EFilingBatchXML element is parent to the following complex element(s):

- Activity. This element is the container for each FinCEN SAR document in the batch. All BSA data related to a single FinCEN SAR document must be recorded within the <Activity> element. The number of <Activity> elements will depend on the number of FinCEN SAR documents being reported in the batch.

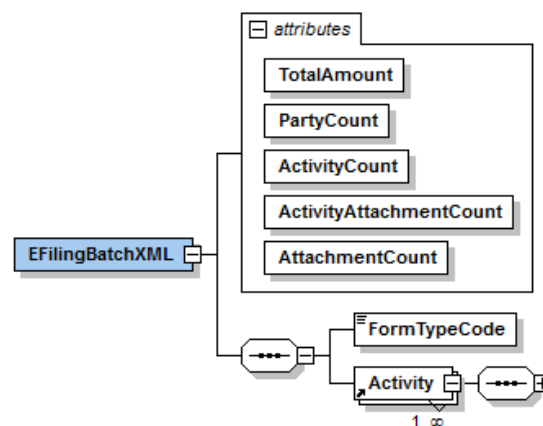

2.1.3. Activity

Each FinCEN SAR document in the batch must begin with the <Activity> element. It identifies all information related to a single FinCEN SAR, including (but not limited to) the transmitter, the reporting financial institution (i.e. filing institution), the financial institution(s) where activity occurred, the subject(s), and suspicious activity details such as the total amount involved, type(s) of suspicious activities, etc. There is no limit to the number of <Activity> elements that may be recorded in the batch; however, the total size of the batch file must not exceed 60MB.

The <Activity> element is parent to the following complex element(s):

- **ActivityAssociation.** This element is the container for the type of filing (i.e. Initial report, Correct/amend prior report, Continuing activity report, and/or Joint filing) for the FinCEN SAR.
- **ActivitySupportDocument.** This element is the container for information about the supporting document as an attachment to the FinCEN SAR being filed.
- **Party.** This element is the container for any person (individual or entity) associated with the FinCEN SAR, specifically, the transmitter [of the batch file], the transmitter contact, the filing institution and contact office, the law enforcement contact agency and point of contact, the financial institution where activity occurred, and the subject. NOTE: The financial institution where an account is held and the branch location where activity occurred are not recorded at the activity level, but rather, within the corresponding party at the activity level that the financial institution and/or branch are associated with.
- **SuspiciousActivity.** This element is the container for information about the suspicious activity, such as the total amount involved and the type of suspicious activity.
- **ActivityIPAddress.** This element is the container for information about IP address involved in the suspicious activity.
- **CyberEventIndicators.** This element is the container for information about cyber event involved in the suspicious activity.
- **Assets.** This element is the container for information about asset involved in the suspicious activity, specifically the product type, instrument type, and/or payment mechanism.
- **AssetsAttribute.** This element is the container for information about the asset attribute involved in the suspicious activity, whether it be a type of commodity, product/instrument, market where traded, and/or CUSIP number.
- **ActivityNarrativeInformation.** This element is the container for information about narrative description associated with the FinCEN SAR.

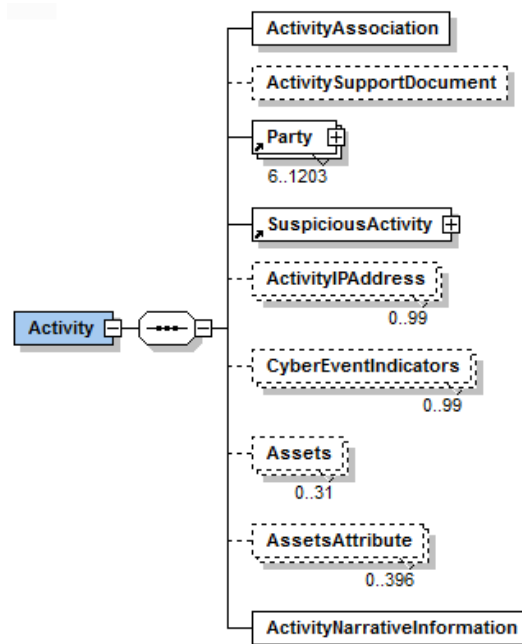

2.1.4. Party

Each FinCEN SAR activity in the batch must include a separate Party element identifying the following persons: Transmitter, Transmitter Contact, Filing Institution, Designated Contact Office, Law Enforcement Agency (if any), Law Enforcement Name (if any), Financial Institution(s) Where Activity Occurred, Branch(s) Where Activity Occurred (if any), and Subject(s) (Note: If reporting account information related to a subject, the financial institution where the account is held will be recorded as a separate Party element as well.). A maximum occurrence of 1203 total Party elements may be recorded at the activity level for each FinCEN SAR activity in the batch. If one or more branches and/or financial institutions where accounts are held are associated with a FinCEN SAR, a maximum of 99 branches and 99 financial institutions (where accounts are held) may be recorded for the FinCEN SAR in addition to the 1203 maximum mentioned above.

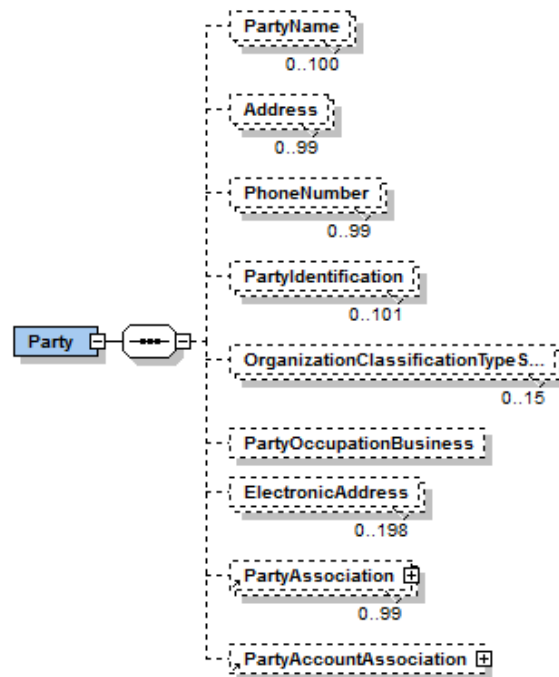

Transmitter (Required)

This is the person (individual or entity) handling the data accumulation and formatting of the batch file. Each FinCEN SAR Activity element in the batch must include a Party element that identifies the batch transmitter. *The batch transmitter should be identical for each FinCEN SAR.* There must be only one occurrence of this party for each FinCEN SAR Activity in the batch.

Transmitter Contact (Required)

This is the official contact for the transmitter. Each FinCEN SAR Activity element in the batch must include a Party element that identifies the point of contact for the batch transmitter. *The transmitter contact should be identical for each FinCEN SAR.* There must be only one occurrence of this party for each FinCEN SAR Activity in the batch.

Filing Institution (Required)

This is the entity responsible for filing the FinCEN SAR, such as a reporting financial institution or a holding or other parent company filling for its subsidiaries. There must be only one occurrence of this party for each FinCEN SAR Activity in the batch. This party corresponds with Part IV of the FinCEN SAR.

Designated Contact Office (Required)

This is the administrative office that should be contacted to obtain additional information about the FinCEN SAR. There must be only one occurrence of this party for each FinCEN SAR Activity in the batch. This party corresponds with Part IV (Items 93-94) of the FinCEN SAR.

LE Contact Agency (if any)

This is the law enforcement agency (if any) that has been informed of the suspicious activity. There may only be one occurrence of this party for each FinCEN SAR Activity in the batch. This party corresponds with Part IV (Item 89) of the FinCEN SAR.

LE Contact Name (if any)

This is the person at law enforcement agency (if any) contacted regarding the suspicious activity. There may only be one occurrence of this party for each FinCEN SAR Activity in the batch. This party corresponds with Part IV (Items 90-92) of the FinCEN SAR.

Financial Institution Where Activity Occurred (Required)

This is the financial institution where the suspicious activity occurred. There must be at least one occurrence (not to exceed 99) of this party for each FinCEN SAR Activity in the batch. This party corresponds with Part III (Items 51-67, 69a). If a branch location associated with the financial institution where activity occurred is also involved, information about the branch should be recorded in a separate party element under the parent element <PartyAssociation> (see PartyAssociation below).

Branch Where Activity Occurred (if any)

This is the branch location where activity occurred. A branch is a location (such as an office or ATM) owned by the financial institution but located separately from the financial institution's headquarters. Generally, a branch operates under the same TIN as the financial institution. No more than 99 branches may be recorded for each FinCEN SAR in the batch. This party corresponds with Part III (Items 68-74) of the FinCEN SAR.

Subject (Required)

This is the subject involved in the suspicious activity. There must be at least one occurrence (not to exceed 999) of this party for each FinCEN SAR Activity in the batch. This party corresponds with Part I (Items 3-28) of the FinCEN SAR. Persons who are victims of the suspicious activity are not subjects and should not be recorded for this party. Victim information, if necessary for a complete description of the suspicious activity, should be recorded in the narrative. If the subject is or all subjects are unknown, record a single party for the subject with "all critical subject information unavailable" indicated and record the nature of the unknown subject(s) in the narrative. If the suspicious activity involves known and unknown subjects, record a separate party for each known subject and record the nature of the unknown subject(s) in the narrative (when there are known subjects involved, do not include a party element for unknown subjects.).

2.1.5. SuspiciousActivity

As the container for information about the details of the suspicious activity, this element identifies information such as the total amount involved and the type of suspicious activity. This element must be recorded after the final Party element is recorded for the FinCEN SAR. There must only be one occurrence of this element for each FinCEN SAR Activity in the batch. This element corresponds with Part II (Items 29-31) of the FinCEN SAR.

Within this element is the sub-element <SuspiciousActivityClassification>, which must be recorded at least once per FinCEN SAR (but no more than 99 total). This element is the container for information about the specific type(s) and subtype(s) of suspicious activity, such as Structuring→"Transaction(s) below CTR threshold", Terrorist financing→"Known or suspended terrorist/terrorist group", etc. This element corresponds with Part II (Items 32-42) of the FinCEN SAR.

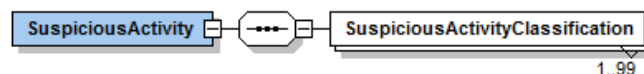

3. FinCEN SAR XML Batch Reporting Requirements

This section describes in detail the reporting requirements for each element in the FinCEN SAR batch.

3.1. Element Definition Overview

Each element in this user guide is defined using the following terms:

Item	Description
Element Name	This is the name that must be used when recording the element.
minOccurs/maxOccurs	This defines the number of times the element can occur for the parent element. <ul style="list-style-type: none"> • MinOccurs. The minimum number of times this element may be recorded for the parent element (e.g. minOccurs=0 means this element is only required under certain conditions while minOccurs=1 means at least one of the element must be recorded for the parent element in the FinCEN SAR.) • MaxOccurs. The maximum number of times this element may be recorded for the parent element (e.g. maxOccurs=999 means this element can occur up to 999 times in the same FinCEN SAR.)
Description	This is the summary description of the element. Also included in the description is a list of sub-elements associated with the element (if applicable) as well as any special requirements for when (and when not) to record the element.
Attribute(s)	This specifies the attribute(s) that are required to be recorded for the element. Note: Various elements contain the SeqNum attribute used to identify the associated element in the batch file. The value recorded for this attribute must be numeric and unique.
Parent Element	This identifies the element's container element. The <Parent> element contains sub elements and is considered a complex element.
Element Restriction(s)	This specifies the requirement level for the element; specifically, under what conditions the element should be recorded: <ul style="list-style-type: none"> • Required. The element must be recorded for the <Parent> element. • Conditionally Required means that the element should only be recorded when certain conditions apply. NOTE: If neither of the above requirement levels are specified in this field, then the element is not required. However, a field that is not required does not mean that it is optional. All fields require an entry when the filer has the relevant data.
Value Restriction(s)	This specifies any requirements and/or restrictions in terms of the value recorded for the element. <ul style="list-style-type: none"> • Required. A value must be recorded for the element. • Conditionally Required. A value may or may not be recorded for the element depending on whether or not certain conditions apply.
Remarks	This specifies any additional information about the element to assist with reporting; including: <ul style="list-style-type: none"> • Reporting conditions that may result in a batch rejection. • Reporting conditions that may result in a batch accepted with warnings.
Example	This provides one or more examples of how to record the element.

3.2. Batch Validation (Form & Fit) Overview

IMPORTANT: FinCEN strongly encourages that filers first test their XML batch files for schema compliance using the schemas available at www.fincen.gov/base. Your batch file should pass schema validation before you attempt to submit to FinCEN; otherwise, it will be at risk of being rejected.

It is important to note that if the batch file does not adhere to the basic format described in this guide in accordance with the FinCEN SAR XML batch schema, then the batch will fail validation and will not be accepted by FinCEN.

Here is a list of general schema requirements that your batch must adhere to in addition to the data requirements described for each element throughout this guide. These schema requirements apply to all elements in the batch:

- Element names must include the prefix "fc2" in both the opening tag and closing tag.
- Element names must be spelled correctly and in the correct case. Do NOT include spaces at the beginning or ending of the element names.
- Elements must have a matching closing tag (which includes a self-closing tag in the event that no value is recorded for the element).
- Elements must be in the correct sequence.
- Elements must be recorded when the minOccurs=1 (or greater than 1).
- Elements must not be recorded more than the maxOccurs value for the associated <Parent> element.
- Element values must not exceed the maximum specified character limit.
- Element values must not include leading and/or trailing spaces.
- Element values must not include non-printable characters, such as carriage returns, line feeds, and tabs.
- Element values must not contain duplicate entries within a single activity unless expressly permitted (*for example, a Subject party type may contain one legal name and up to 99 alternate names; therefore, if more than one legal name is recorded for the Subject, the batch file will fail validation and will not be accepted*).

4. FinCEN SAR XML Element Requirements

The following defines each element in the FinCEN SAR XML batch in the order in which they can be recorded.

4.1. XML declaration/prolog

Element Name:	?xml	minOccurs:	1	maxOccurs:	1
Description:	XML declaration/prolog. This is the XML declaration which specifies the XML version and character encoding used in the file. The XML declaration must appear on the first line of the file.				
Attribute(s):	The following data must be recorded for XML declaration/prolog:				
	Name	Description			
	version	The version number of the XML. The value recorded must be "1.0"			
	encoding	The character encoding, which must be UTF-8, used for the XML. The value recorded must be "UTF-8"			
Parent Element:	n/a				
Element Restriction(s):	This declaration must be recorded.				
Value Restriction(s):	The value provided must adhere to the following requirements: <ul style="list-style-type: none"> • <?xml version="1.0" encoding="UTF-8"?> 				
Remarks:	The batch submission will be <u>rejected</u> if any of the following conditions are true: <ul style="list-style-type: none"> • The XML declaration/prolog is not recorded with the required values (see Value Restriction(s) above) or it is not recorded on the first line of the batch file. 				
Example:	<?xml version="1.0" encoding="UTF-8"?>				

4.2. EFilingBatchXML Elements

Element Name:	EfilingBatchXML	minOccurs:	1	maxOccurs:	1																		
Description:	<p>XML batch (header). This is the container for the contents of the batch file. This element is the root element in the FinCEN SAR XML batch file and the container element for all suspicious activities included in the batch. As the root element, it must be the first element recorded in the file, directly following the XML declaration/prolog. The following sub-elements are associated with this element:</p> <table border="1"> <thead> <tr> <th>Name</th> <th>minOccurs</th> <th>maxOccurs</th> <th>Category</th> </tr> </thead> <tbody> <tr> <td>FormTypeCode</td> <td>1</td> <td>1</td> <td>Simple</td> </tr> <tr> <td>Activity</td> <td>1</td> <td>unbounded</td> <td>Complex</td> </tr> </tbody> </table>					Name	minOccurs	maxOccurs	Category	FormTypeCode	1	1	Simple	Activity	1	unbounded	Complex						
Name	minOccurs	maxOccurs	Category																				
FormTypeCode	1	1	Simple																				
Activity	1	unbounded	Complex																				
Attribute(s)	<p>The following attributes must be recorded for this element:</p> <table border="1"> <thead> <tr> <th>Name</th> <th>Description</th> </tr> </thead> <tbody> <tr> <td>ActivityCount</td> <td>The count of all <Activity> elements in the batch</td> </tr> <tr> <td>TotalAmount</td> <td>The sum of all <TotalSuspiciousAmountText> element amounts recorded in the batch</td> </tr> <tr> <td>PartyCount</td> <td>The count of all <Party> elements in the batch where the <ActivityPartyTypeCode> is equal to "33" (Subject)</td> </tr> <tr> <td>ActivityAttachmentCount</td> <td>The count of all <Activity> elements in the batch where the <OriginalAttachmentFileName> element is recorded with a value referencing the file name of the FinCEN SAR attachment</td> </tr> <tr> <td>AttachmentCount</td> <td>The count of all <OriginalAttachmentFileName> elements in the batch that contain a value referencing the file name of the FinCEN SAR attachment</td> </tr> <tr> <td>xsi:schemaLocation</td> <td>www.fincen.gov/base https://www.fincen.gov/base/EFL_FinCEN SARXBatchSchema.xsd</td> </tr> <tr> <td>xmlns:xsi</td> <td>http://www.w3.org/2001/XMLSchema-instance</td> </tr> <tr> <td>xmlns:fc2</td> <td>www.fincen.gov/base</td> </tr> </tbody> </table>					Name	Description	ActivityCount	The count of all <Activity> elements in the batch	TotalAmount	The sum of all <TotalSuspiciousAmountText> element amounts recorded in the batch	PartyCount	The count of all <Party> elements in the batch where the <ActivityPartyTypeCode> is equal to "33" (Subject)	ActivityAttachmentCount	The count of all <Activity> elements in the batch where the <OriginalAttachmentFileName> element is recorded with a value referencing the file name of the FinCEN SAR attachment	AttachmentCount	The count of all <OriginalAttachmentFileName> elements in the batch that contain a value referencing the file name of the FinCEN SAR attachment	xsi:schemaLocation	www.fincen.gov/base https://www.fincen.gov/base/EFL_FinCEN SARXBatchSchema.xsd	xmlns:xsi	http://www.w3.org/2001/XMLSchema-instance	xmlns:fc2	www.fincen.gov/base
Name	Description																						
ActivityCount	The count of all <Activity> elements in the batch																						
TotalAmount	The sum of all <TotalSuspiciousAmountText> element amounts recorded in the batch																						
PartyCount	The count of all <Party> elements in the batch where the <ActivityPartyTypeCode> is equal to "33" (Subject)																						
ActivityAttachmentCount	The count of all <Activity> elements in the batch where the <OriginalAttachmentFileName> element is recorded with a value referencing the file name of the FinCEN SAR attachment																						
AttachmentCount	The count of all <OriginalAttachmentFileName> elements in the batch that contain a value referencing the file name of the FinCEN SAR attachment																						
xsi:schemaLocation	www.fincen.gov/base https://www.fincen.gov/base/EFL_FinCEN SARXBatchSchema.xsd																						
xmlns:xsi	http://www.w3.org/2001/XMLSchema-instance																						
xmlns:fc2	www.fincen.gov/base																						
Parent Element:	n/a																						
Element Restriction(s):	Required. This element must be recorded.																						
Value Restriction(s):	n/a																						
Remarks:	<p>The batch submission will be <u>rejected</u> if any of the following conditions are true:</p> <ul style="list-style-type: none"> The element is not recorded. One or more of the attributes are missing, incorrectly formatted, or contain an invalid value. The reported attribute count does not match the actual count. 																						
Example:	<pre><fc2:EfilingBatchXML ActivityCount="2" TotalAmount="40000" PartyCount="4" ActivityAttachmentCount="2" AttachmentCount="2" xsi:schemaLocation="www.fincen.gov/base EFL_FinCEN SARXBatchSchema.xsd" xmlns:xsi="http://www.w3.org/2001/XMLSchema-instance" xmlns:fc2="www.fincen.gov/base"></pre>																						

Element Name:	FormTypeCode	minOccurs:	1	maxOccurs:	1
Description:	Form type (code). This element identifies the type of form being reported in the batch.				
Attribute(s)	n/a				
Parent Element:	EfilingBatchXML				
Element Restriction(s):	Required. This element must be recorded.				
Value Restriction(s):	The value provided must equal: SARX				
Remarks:	<p>The batch submission will be <u>rejected</u> if any of the following conditions are true:</p> <ul style="list-style-type: none"> The element is not recorded. The value is null or not equal to FinCEN SARX. 				

Element Name:	FormTypeCode	minOccurs:	1	maxOccurs:	1
Example:	<fc2:FormTypeCode>SARX</fc2:FormTypeCode>				

Element Name:	Activity	See <i>Activity Elements</i> for details.			
---------------	----------	---	--	--	--

4.3. Activity Elements

Element Name:	Activity	minOccurs:	1	maxOccurs:	unbounded																																																				
Description:	<p>Activity (header). This is the container for all information related to the FinCEN SAR. The first <Activity> element in the batch file must directly follow the <FormTypeCode> element. The batch must contain at least one occurrence of this element. There is no maximum occurrence value set for this element; however, the total size of the batch file must not exceed 60MB. The following sub-elements are associated with this element:</p> <table border="1"> <thead> <tr> <th>Name</th> <th>minOccurs</th> <th>maxOccurs</th> <th>Category</th> </tr> </thead> <tbody> <tr> <td>EfilingPriorDocumentNumber</td> <td>0</td> <td>1</td> <td>Simple</td> </tr> <tr> <td>FilingDateText</td> <td>1</td> <td>1</td> <td>Simple</td> </tr> <tr> <td>FilingInstitutionNotetoFinCEN</td> <td>0</td> <td>1</td> <td>Simple</td> </tr> <tr> <td>ActivityAssociation</td> <td>1</td> <td>1</td> <td>Complex</td> </tr> <tr> <td>ActivitySupportDocument</td> <td>0</td> <td>1</td> <td>Complex</td> </tr> <tr> <td>Party</td> <td>6</td> <td>1203</td> <td>Complex</td> </tr> <tr> <td>SuspiciousActivity</td> <td>1</td> <td>1</td> <td>Complex</td> </tr> <tr> <td>ActivityIPAddress</td> <td>0</td> <td>99</td> <td>Complex</td> </tr> <tr> <td>CyberEventIndicators</td> <td>0</td> <td>99</td> <td>Complex</td> </tr> <tr> <td>Assets</td> <td>0</td> <td>31</td> <td>Complex</td> </tr> <tr> <td>AssetsAttribute</td> <td>0</td> <td>396</td> <td>Complex</td> </tr> <tr> <td>ActivityNarrativeInformation</td> <td>1</td> <td>1</td> <td>Complex</td> </tr> </tbody> </table>					Name	minOccurs	maxOccurs	Category	EfilingPriorDocumentNumber	0	1	Simple	FilingDateText	1	1	Simple	FilingInstitutionNotetoFinCEN	0	1	Simple	ActivityAssociation	1	1	Complex	ActivitySupportDocument	0	1	Complex	Party	6	1203	Complex	SuspiciousActivity	1	1	Complex	ActivityIPAddress	0	99	Complex	CyberEventIndicators	0	99	Complex	Assets	0	31	Complex	AssetsAttribute	0	396	Complex	ActivityNarrativeInformation	1	1	Complex
Name	minOccurs	maxOccurs	Category																																																						
EfilingPriorDocumentNumber	0	1	Simple																																																						
FilingDateText	1	1	Simple																																																						
FilingInstitutionNotetoFinCEN	0	1	Simple																																																						
ActivityAssociation	1	1	Complex																																																						
ActivitySupportDocument	0	1	Complex																																																						
Party	6	1203	Complex																																																						
SuspiciousActivity	1	1	Complex																																																						
ActivityIPAddress	0	99	Complex																																																						
CyberEventIndicators	0	99	Complex																																																						
Assets	0	31	Complex																																																						
AssetsAttribute	0	396	Complex																																																						
ActivityNarrativeInformation	1	1	Complex																																																						
Attribute(s)	<p>The following attributes must be recorded for this element:</p> <table border="1"> <thead> <tr> <th>Name</th> <th>Description</th> </tr> </thead> <tbody> <tr> <td>SeqNum</td> <td>The value recorded for this attribute must be numeric and unique. It may contain any numeric value up to 19 characters in length.</td> </tr> </tbody> </table>					Name	Description	SeqNum	The value recorded for this attribute must be numeric and unique. It may contain any numeric value up to 19 characters in length.																																																
Name	Description																																																								
SeqNum	The value recorded for this attribute must be numeric and unique. It may contain any numeric value up to 19 characters in length.																																																								
Parent Element:	EFilingBatchXML																																																								
Element Restriction(s):	Required. This element must be recorded.																																																								
Value Restriction(s):	n/a																																																								
Remarks:	<p>The batch submission will be <u>rejected</u> if any of the following conditions are true:</p> <ul style="list-style-type: none"> The element is not recorded. The element is missing a "SeqNum" attribute. The element contains a "SeqNum" attribute with a duplicate or invalid value. 																																																								
Example:	<pre><fc2:Activity SeqNum="1"> <fc2:EfilingPriorDocumentNumber>31000000000001</fc2:EfilingPriorDocumentNumber> <fc2:FilingDateText>20171101</fc2:FilingDateText> <fc2:FilingInstitutionNotetoFinCEN>Filing institution note to FinCEN</fc2:FilingInstitutionNotetoFinCEN> <fc2:ActivityAssociation SeqNum="2"></pre>																																																								

Element Name:	EfilingPriorDocumentNumber	minOccurs:	0	maxOccurs:	1
Description:	<p>Prior report BSA Identifier (number). This element identifies the BSA Identifier (BSA ID) of the previously-filed FinCEN SAR when filing a correction/amendment and/or a continuing activity report. This element corresponds with the following item(s):</p> <ul style="list-style-type: none"> 1e. Prior report BSA Identification Number <p><i>Please refer to Attachment C for additional information regarding the above item(s).</i></p>				
Attribute(s)	n/a				
Parent Element:	Activity				
Element Restriction(s):	Conditionally Required. Record this element when the FinCEN SAR being filed corrects/amends a prior report and/or is a continuing activity report; otherwise, do not record this element.				
Value Restriction(s):	The value provided must adhere to the following requirements: 14-digit numeric BSA ID (if known); 14 consecutive zeros, i.e. "00000000000000" (if the BSA ID is unknown).				
Remarks:	<p>The batch submission will be <u>accepted with warning</u> if any of the following conditions are true:</p> <ul style="list-style-type: none"> The element is recorded but without a value (i.e. the value is null). The value recorded does not equal 14 numeric characters. The element is not recorded and one or both of the following elements contains a "Y" value: <ul style="list-style-type: none"> <CorrectsAmendsPriorReportIndicator> <ContinuingActivityReportIndicator> The element is recorded (with a valid value) and none of the of the following elements contains a "Y" value: <ul style="list-style-type: none"> <CorrectsAmendsPriorReportIndicator> <ContinuingActivityReportIndicator> 				
Example:	<fc2:EfilingPriorDocumentNumber>31000000000001</fc2:EfilingPriorDocumentNumber>				

Element Name:	FilingDateText	minOccurs:	1	maxOccurs:	1
Description:	<p>Date filed (date). This element identifies the date in which the FinCEN SAR is being filed electronically through FinCEN's BSA E-Filing System. This element corresponds with the following item(s):</p> <ul style="list-style-type: none"> 95. Date filed <p><i>Please refer to Attachment C for additional information regarding the above item(s).</i></p>				
Attribute(s)	n/a				
Parent Element:	Activity				
Element Restriction(s):	Required. This element must be recorded.				
Value Restriction(s):	The value provided must adhere to the following requirements: 8 numeric characters in the format YYYYMMDD where YYYY = year, MM = month, and DD = day. Single digit days or months must be prefaced by a zero.				
Remarks:	<p>The batch submission will be <u>rejected</u> if any of the following conditions are true:</p> <ul style="list-style-type: none"> The element is not recorded. The element is recorded but without a value (i.e. the value is null). The value recorded for the element is not a valid date in the format YYYYMMDD. The value recorded for the element is a date greater than the current date or less than January 1, 2000. 				
Example:	<fc2:FilingDateText>20171101</fc2:FilingDateText>				

Element Name:	FilingInstitutionNotetoFinCEN	minOccurs:	0	maxOccurs:	1
Description:	<p>Filing Institution Note to FinCEN (text). This element allows the filer to alert FinCEN that this FinCEN SAR is being filed in response to a current specific geographic targeting order (GTO) or advisory or other activity. This element corresponds with the following item(s):</p> <ul style="list-style-type: none"> 2. Filing Institution Note to FinCEN <p><i>Please refer to Attachment C for additional information regarding the above item(s).</i></p>				
Attribute(s)	n/a				
Parent Element:	Activity				

Element Name:	FilingInstitutionNotetoFinCEN	minOccurs:	0	maxOccurs:	1
Element Restriction(s):	Record this element when the FinCEN SAR being filed is in response to a current specific geographic targeting order (GTO) or advisory or other activity; otherwise, do not record this element.				
Value Restriction(s):	The value provided must adhere to the following requirements: 50 characters or less				
Remarks:	n/a				
Example:	<fc2:FilingInstitutionNotetoFinCEN>Filing institution note to FinCEN</fc2:FilingInstitutionNotetoFinCEN>				

Element Name:	ActivityAssociation	See <i>ActivityAssociation Elements</i> for details.
---------------	---------------------	--

Element Name:	ActivitySupportDocument	See <i>ActivitySupportDocument Elements</i> for details.
---------------	-------------------------	--

Element Name:	Party	See <i>Party Elements</i> for details.
---------------	-------	--

Element Name:	SuspiciousActivity	See <i>SuspiciousActivity Elements</i> for details.
---------------	--------------------	---

Element Name:	ActivityIPAddress	See <i>ActivityIPAddress Elements</i> for details.
---------------	-------------------	--

Element Name:	CyberEventIndicators	See <i>CyberEventIndicators Elements</i> for details.
---------------	----------------------	---

Element Name:	Assets	See <i>Assets Elements</i> for details.
---------------	--------	---

Element Name:	AssetsAttribute	See <i>AssetsAttribute Elements</i> for details.
---------------	-----------------	--

Element Name:	ActivityNarrativeInformation	See <i>ActivityNarrativeInformation Elements</i> for details.
---------------	------------------------------	---

4.4. ActivityAssociation Elements

Element Name:	ActivityAssociation	minOccurs:	1	maxOccurs:	1																				
Description:	<p>Type of filing (header). This element is the container for information about the type of filing associated with the FinCEN SAR. The following sub-elements are associated with this element:</p> <table border="1"> <thead> <tr> <th>Name</th> <th>minOccurs</th> <th>maxOccurs</th> <th>Category</th> </tr> </thead> <tbody> <tr> <td>ContinuingActivityReportIndicator</td> <td>0</td> <td>1</td> <td>Simple</td> </tr> <tr> <td>CorrectsAmendsPriorReportIndicator</td> <td>0</td> <td>1</td> <td>Simple</td> </tr> <tr> <td>InitialReportIndicator</td> <td>0</td> <td>1</td> <td>Simple</td> </tr> <tr> <td>JointReportIndicator</td> <td>0</td> <td>1</td> <td>Simple</td> </tr> </tbody> </table> <p><i>*At least one of the above sub-elements must be recorded.</i></p> <p>This element corresponds with the following item(s):</p> <ul style="list-style-type: none"> • 1. Type of filing <ul style="list-style-type: none"> ○ 1a. Initial report 					Name	minOccurs	maxOccurs	Category	ContinuingActivityReportIndicator	0	1	Simple	CorrectsAmendsPriorReportIndicator	0	1	Simple	InitialReportIndicator	0	1	Simple	JointReportIndicator	0	1	Simple
Name	minOccurs	maxOccurs	Category																						
ContinuingActivityReportIndicator	0	1	Simple																						
CorrectsAmendsPriorReportIndicator	0	1	Simple																						
InitialReportIndicator	0	1	Simple																						
JointReportIndicator	0	1	Simple																						

Element Name:	ActivityAssociation	minOccurs:	1	maxOccurs:	1				
	<ul style="list-style-type: none"> o 1b. Correct/Amend prior report o 1c. Continuing activity report o 1d. Joint report <p><i>Please refer to Attachment C for additional information regarding the above item(s).</i></p>								
Attribute(s)	<p>The following attributes must be recorded for this element:</p> <table border="1"> <thead> <tr> <th>Name</th> <th>Description</th> </tr> </thead> <tbody> <tr> <td>SeqNum</td> <td>The value recorded for this attribute must be numeric and unique. It may contain any numeric value up to 19 characters in length.</td> </tr> </tbody> </table>					Name	Description	SeqNum	The value recorded for this attribute must be numeric and unique. It may contain any numeric value up to 19 characters in length.
Name	Description								
SeqNum	The value recorded for this attribute must be numeric and unique. It may contain any numeric value up to 19 characters in length.								
Parent Element:	Activity								
Element Restriction(s):	Required. This element must be recorded.								
Value Restriction(s):	n/a								
Remarks:	<p>The batch submission will be <u>rejected</u> if any of the following conditions are true:</p> <ul style="list-style-type: none"> • The element is not recorded. • The element is missing a "SeqNum" attribute. • The element contains a "SeqNum" attribute with a duplicate or invalid value. • The element is recorded but none of the following sub-elements are recorded with a "Y" value: <ul style="list-style-type: none"> o <InitialReportIndicator> o <CorrectsAmendsPriorReportIndicator> o <ContinuingActivityReportIndicator> <p>The batch submission will be <u>accepted with warning</u> if any of the following conditions are true:</p> <ul style="list-style-type: none"> • The following sub-element combinations are recorded with a "Y" value: <ul style="list-style-type: none"> o <InitialReportIndicator> AND (<CorrectsAmendsPriorReportIndicator> AND/OR <ContinuingActivityReportIndicator>) 								
Example:	<pre><fc2:ActivityAssociation SeqNum="2"> <fc2:ContinuingActivityReportIndicator>Y</fc2:ContinuingActivityReportIndicator> <fc2:CorrectsAmendsPriorReportIndicator>Y</fc2:CorrectsAmendsPriorReportIndicator> </fc2:ActivityAssociation></pre>								

Element Name:	ContinuingActivityReportIndicator	minOccurs:	0	maxOccurs:	1
Description:	<p>Continuing activity report (indicator). This element declares that the FinCEN SAR being filed continues reporting on a previously-reported suspicious activity. This element corresponds with the following item(s):</p> <ul style="list-style-type: none"> • 1c. Continuing activity report <p><i>Please refer to Attachment C for additional information regarding the above item(s).</i></p>				
Attribute(s)	n/a				
Parent Element:	ActivityAssociation				
Element Restriction(s):	<p>Conditionally Required. Record this element when the FinCEN SAR being filed continues reporting on a previously-reported suspicious activity; otherwise, do not record this element.</p> <p>If this element is recorded, the following elements must also be recorded:</p> <ul style="list-style-type: none"> • <EFilingPriorDocumentNumber> • <CumulativeTotalViolationAmountText> <p>The <ContinuingActivityReportIndicator> element may be recorded on its own or in conjunction with one or both of the following "Type of filing" elements:</p> <ul style="list-style-type: none"> • <CorrectsAmendsPriorReportIndicator> • <JointReportIndicator> 				
Value Restriction(s):	The value provided must adhere to the following requirements: "Y" (to indicate "Continuing activity report")				

Element Name:	ContinuingActivityReportIndicator	minOccurs:	0	maxOccurs:	1
Remarks:	The batch submission will be <u>rejected</u> if any of the following conditions are true: <ul style="list-style-type: none"> The value recorded is not equal to "Y" or not equal to null. 				
Example:	<fc2:ContinuingActivityReportIndicator>Y</fc2:ContinuingActivityReportIndicator>				

Element Name:	CorrectsAmendsPriorReportIndicator	minOccurs:	0	maxOccurs:	1
Description:	Corrects/Amends prior report (indicator). This element declares that the FinCEN SAR being filed corrects or amends a previously-filed FinCEN SAR. This element corresponds with the following item(s): <ul style="list-style-type: none"> 1b. Correct/Amend prior report <p><i>Please refer to Attachment C for additional information regarding the above item(s).</i></p>				
Attribute(s)	n/a				
Parent Element:	ActivityAssociation				
Element Restriction(s):	Conditionally Required. Record this element when the FinCEN SAR being filed corrects or amends a previously-filed FinCEN SAR; otherwise, do not record this element. <p>If this element is recorded, the following element must also be recorded:</p> <ul style="list-style-type: none"> <EFilingPriorDocumentNumber> <p>The <CorrectsAmendsPriorReportIndicator> element may be recorded on its own or in conjunction with one or both of the following "Type if filing" elements:</p> <ul style="list-style-type: none"> <ContinuingActivityReportIndicator> <JointReportIndicator> 				
Value Restriction(s):	The value provided must adhere to the following requirements: "Y" (to indicate "Continuing activity report")				
Remarks:	The batch submission will be <u>rejected</u> if any of the following conditions are true: <ul style="list-style-type: none"> The value recorded is not equal to "Y" or not equal to null. 				
Example:	<fc2:CorrectsAmendsPriorReportIndicator>Y</fc2:CorrectsAmendsPriorReportIndicator>				

Element Name:	InitialReportIndicator	minOccurs:	0	maxOccurs:	1
Description:	Initial report (indicator). This element declares that the FinCEN SAR being filed is the first report filed on the suspicious activity. This element corresponds with the following item(s): <ul style="list-style-type: none"> 1a. Initial report <p><i>Please refer to Attachment C for additional information regarding the above item(s).</i></p>				
Attribute(s)	n/a				
Parent Element:	ActivityAssociation				
Element Restriction(s):	Conditionally Required. Record this element when the FinCEN SAR being filed is the first report filed on the suspicious activity; otherwise, do not record this element. <p>The <InitialReportIndicator> element may be recorded on its own or in conjunction with the following "Type of filing" element:</p> <ul style="list-style-type: none"> <JointReportIndicator> 				
Value Restriction(s):	The value provided must adhere to the following requirements: "Y" (to indicate "Initial report")				
Remarks:	The batch submission will be <u>rejected</u> if any of the following conditions are true: <ul style="list-style-type: none"> The value recorded is not equal to "Y" or not equal to null. 				
Example:	<fc2:InitialReportIndicator>Y</fc2:InitialReportIndicator>				

Element Name:	JointReportIndicator	minOccurs:	0	maxOccurs:	1
Description:	<p>Joint report (indicator). This element declares that the FinCEN SAR is being filed jointly by two or more financial institutions. This element corresponds with the following item(s):</p> <ul style="list-style-type: none"> 1d. Joint report <p><i>Please refer to Attachment C for additional information regarding the above item(s).</i></p>				
Attribute(s)	n/a				
Parent Element:	ActivityAssociation				
Element Restriction(s):	<p>Conditionally Required. Record this element when the FinCEN SAR is being filed jointly by two or more financial institutions; otherwise, do not record this element.</p> <p>The <JointReportIndicator> element must be recorded in conjunction with at least one of the following "Type of filing" element:</p> <ul style="list-style-type: none"> <ContinuingActivityReportIndicator> <CorrectsAmendsPriorReportIndicator> <InitialReportIndicator> <p>Furthermore, the <JointReportIndicator> element should <u>not</u> be recorded if one or more of the following "subject relationship to institution" elements are indicated:</p> <ul style="list-style-type: none"> <DirectorIndicator> <EmployeeIndicator> <OfficerIndicator> <OwnerShareholderIndicator> 				
Value Restriction(s):	The value provided must adhere to the following requirements: "Y" (to indicate "Joint report")				
Remarks:	<p>The batch submission will be rejected if any of the following conditions are true:</p> <ul style="list-style-type: none"> The value recorded is not equal to "Y" or not equal to null. 				
Example:	<fc2:JointReportIndicator>Y</fc2:JointReportIndicator>				

4.5. ActivitySupportDocument Elements

Element Name:	ActivitySupportDocument	minOccurs:	0	maxOccurs:	1								
Description:	<p>Supporting Document (header). This element is the container for information about the supporting document as an attachment to the FinCEN SAR being filed. The contents of the attachment file must be described in the narrative. The attachment file would be most suitable for documenting transaction records that are too numerous to record in the narrative. Do not include any other supporting documentation with the FinCEN SAR. Instead, describe in narrative other supporting documentation not included in the attachment. The following sub-element is associated with this element:</p> <table border="1" data-bbox="443 1335 1385 1413"> <thead> <tr> <th>Name</th> <th>minOccurs</th> <th>maxOccurs</th> <th>Category</th> </tr> </thead> <tbody> <tr> <td>OriginalAttachmentFileName</td> <td>1</td> <td>1</td> <td>Simple</td> </tr> </tbody> </table> <p>This element corresponds with the following item(s):</p> <ul style="list-style-type: none"> Part V. Suspicious Activity Report – Attachment <p><i>Please refer to Attachment C for additional information regarding the above item(s).</i></p>					Name	minOccurs	maxOccurs	Category	OriginalAttachmentFileName	1	1	Simple
Name	minOccurs	maxOccurs	Category										
OriginalAttachmentFileName	1	1	Simple										
Attribute(s)	<p>The following attributes must be recorded for this element:</p> <table border="1" data-bbox="443 1610 1385 1724"> <thead> <tr> <th>Name</th> <th>Description</th> </tr> </thead> <tbody> <tr> <td>SeqNum</td> <td>The value recorded for this attribute must be numeric and unique. It may contain any numeric value up to 19 characters in length.</td> </tr> </tbody> </table>					Name	Description	SeqNum	The value recorded for this attribute must be numeric and unique. It may contain any numeric value up to 19 characters in length.				
Name	Description												
SeqNum	The value recorded for this attribute must be numeric and unique. It may contain any numeric value up to 19 characters in length.												
Parent Element:	Activity												
Element Restriction(s):	Record this element when the FinCEN SAR includes an attachment containing tabular data (such as transaction data) that provides additional suspicious activity information not suitable for inclusion in the narrative; otherwise, do not record this element.												

Element Name:	ActivitySupportDocument	minOccurs:	0	maxOccurs:	1
Value Restriction(s):	n/a				
Remarks:	The batch submission will be rejected if any of the following conditions are true: <ul style="list-style-type: none"> The element is missing a "SeqNum" attribute. The element contains a "SeqNum" attribute with a duplicate or invalid value. 				
Example:	<pre><fc2:ActivitySupportDocument SeqNum="3"> <fc2:OriginalAttachmentFileName>FinCEN SAR_Attachment.csv</fc2:OriginalAttachmentFileName> </fc2:ActivitySupportDocument></pre>				

Element Name:	OriginalAttachmentFileName	minOccurs:	1	maxOccurs:	1
Description:	Attachment file name (text). This element declares the attachment file name included with the FinCEN SAR being filed. This element corresponds with the following item(s): <ul style="list-style-type: none"> Part V. Suspicious Activity Report – Attachment (File name) <i>Please refer to Attachment C for additional information regarding the above item(s).</i>				
Attribute(s)	n/a				
Parent Element:	ActivitySupportDocument				
Element Restriction(s):	Required. This element must be recorded when the associated parent element is recorded.				
Value Restriction(s):	The value provided must adhere to the following requirements: Enter the attachment file name (e.g. FinCEN SAR_Attachment_1.csv). The attachment file must be an MS Excel-compatible comma separated value (CSV) file with a maximum size of 1 megabyte. Include the ".csv" extension at the end of the file name.				
Remarks:	The batch submission will be rejected if any of the following conditions are true: <ul style="list-style-type: none"> The element is recorded with a valid value but there is no corresponding attachment. The batch submission contains an attachment but the <OriginalAttachmentFileName> element of the associated FinCEN SAR within the batch XML is not recorded or the value is null. 				
Example:	<fc2:OriginalAttachmentFileName>FinCEN SAR_Attachment.csv</fc2:OriginalAttachmentFileName>				

4.6. Party Elements

Element Name:	Party	minOccurs:	6	maxOccurs:	1203
Description:	Party (header). This is the container for information about the individual or entity associated with the FinCEN SAR (at the activity level); specifically, the transmitter [of the batch file], the transmitter contact, the filing institution and contact office, the law enforcement contact agency and point of contact, the financial institution where activity occurred, and the subject.				
	The following tables describe all possible sub-elements for each party type at the activity level:				
	Activity party type code definitions 35 = Transmitter 37 = Transmitter Contact 30 = Filing Institution 8 = Contact Office 18 = LE Contact Agency 19 = LE Contact Name 34 = Financial Institution Where Activity Occurred 33 = Subject				
	1. Transmitter Information (Required Batch Transmitter Information)				
	Name	minOccurs	maxOccurs	Content	
	ActivityPartyTypeCode (Code 35)	1	1	Simple	
	PartyName	1	1	Complex	
	Address	1	1	Complex	
	PhoneNumber	1	1	Complex	

Element Name:	Party	minOccurs:	6	maxOccurs:	1203
	PartyIdentification		1	1	Complex
	2. Transmitter Contact Information (Required Batch Transmitter Information)				
	Name	minOccurs	maxOccurs	Content	
	ActivityPartyTypeCode (Code 37)	1	1	Simple	
	PartyName	1	1	Complex	
	3. Filing Institution (Required FinCEN SAR Part IV, Items 75-82, 87)				
	Name	minOccurs	maxOccurs	Content	
	ActivityPartyTypeCode (Code 30)	1	1	Simple	
	PrimaryRegulatorTypeCode (Item 75)	1	1	Simple	
	PartyName (Items 76, 87)	1	2	Complex	
	Address (Items 82-86)	1	1	Complex	
	PartyIdentification (Items 77, 78, 81, 88)	1	3	Complex	
	OrganizationClassificationTypeSubtype (Items 79, 80)	1	15	Complex	
	4. Contact Office (Required FinCEN SAR Part IV, Items 93-94)				
	Name	minOccurs	maxOccurs	Content	
	ActivityPartyTypeCode (Code 8)	1	1	Simple	
	PartyName (Item 93)	1	1	Complex	
	PhoneNumber (Item 94)	1	1	Complex	
	5. LE Contact Agency (if available FinCEN SAR Part IV, Item 89)				
	Name	minOccurs	maxOccurs	Content	
	ActivityPartyTypeCode (Code 18)	1	1	Simple	
	PartyName (Item 89)	1	1	Complex	
	6. LE Contact Name (if available FinCEN SAR Part IV, Items 90-92)				
	Name	minOccurs	maxOccurs	Content	
	ActivityPartyTypeCode (Code 19)	1	1	Simple	
	ContactDateText (Item 92)	0	1	Simple	
	PartyName (Item 90)	0	1	Complex	
	PhoneNumber (Item 91)	0	1	Complex	
	7. Financial Institution Where Activity Occurred (Required FinCEN SAR Part III, Items 51-66, 69a, 68/69/70-74 if a Branch is involved)				
	Name	minOccurs	maxOccurs	Content	
	ActivityPartyTypeCode (Code 34)	1	1	Simple	
	LossToFinancialAmountText (Item 67)	0	1	Simple	
	NoBranchActivityInvolvedIndicator (Item 69a)	0	1	Simple	
	PayLocationIndicator (Item 56b)	0	1	Simple	
	PrimaryRegulatorTypeCode (Item 52)	1	1	Simple	
	SellingLocationIndicator (Item 56a)	0	1	Simple	
	SellingPayingLocationIndicator (Item 56c)	0	1	Simple	

Element Name:	Party	minOccurs:	6	maxOccurs:	1203																																																																																												
	PartyName (Items 57, 58)		1	2	Complex																																																																																												
	Address (Items 61-65)		1	1	Complex																																																																																												
	PartyIdentification (Items 55, 59, 60, 66)		1	3	Complex																																																																																												
	OrganizationClassificationTypeSubtype (Items 51, 53, 54)		1	12	Complex																																																																																												
	PartyAssociation (Items 68, 69, 70-74)		0	1	Complex																																																																																												
	8. Subject (Required FinCEN SAR Part I, Items 3-28)																																																																																																
	<table border="1"> <thead> <tr> <th>Name</th> <th>minOccurs</th> <th>maxOccurs</th> <th>Content</th> </tr> </thead> <tbody> <tr> <td>ActivityPartyTypeCode</td> <td>1</td> <td>1</td> <td>Simple</td> </tr> <tr> <td>AdmissionConfessionNoIndicator (Item 23b)</td> <td>0</td> <td>1</td> <td>Simple</td> </tr> <tr> <td>AdmissionConfessionYesIndicator (Item 23a)</td> <td>0</td> <td>1</td> <td>Simple</td> </tr> <tr> <td>*AllCriticalSubjectInformationUnavailableIndicator(Item 3b)</td> <td>0</td> <td>1</td> <td>Simple</td> </tr> <tr> <td>BirthDateUnknownIndicator (Item 19a)</td> <td>0</td> <td>1</td> <td>Simple</td> </tr> <tr> <td>BothPurchaserSenderPayeeReceiveIndicator (Item 28c)</td> <td>0</td> <td>1</td> <td>Simple</td> </tr> <tr> <td>FemaleGenderIndicator (Item 8b)</td> <td>0</td> <td>1</td> <td>Simple</td> </tr> <tr> <td>IndividualBirthDateText (Item 19)</td> <td>0</td> <td>1</td> <td>Simple</td> </tr> <tr> <td>MaleGenderIndicator (Item 8a)</td> <td>0</td> <td>1</td> <td>Simple</td> </tr> <tr> <td>NoKnownAccountInvolvedIndicator (Item 27a)</td> <td>0</td> <td>1</td> <td>Simple</td> </tr> <tr> <td>PartyAsEntityOrganizationIndicator (Item 3a)</td> <td>0</td> <td>1</td> <td>Simple</td> </tr> <tr> <td>PayeeReceiverIndicator (Item 28b)</td> <td>0</td> <td>1</td> <td>Simple</td> </tr> <tr> <td>PurchaserSenderIndicator (Item 28a)</td> <td>0</td> <td>1</td> <td>Simple</td> </tr> <tr> <td>UnknownGenderIndicator (Item 8c)</td> <td>0</td> <td>1</td> <td>Simple</td> </tr> <tr> <td>*PartyName (Items 4-7, 9)</td> <td>1</td> <td>100</td> <td>Complex</td> </tr> <tr> <td>*Address (Items 11-15)</td> <td>1</td> <td>99</td> <td>Complex</td> </tr> <tr> <td>PhoneNumber (Items 20, 21)</td> <td>0</td> <td>99</td> <td>Complex</td> </tr> <tr> <td>*PartyIdentification (Items 16-18)</td> <td>2</td> <td>100</td> <td>Complex</td> </tr> <tr> <td>PartyOccupationBusiness (Item 10)</td> <td>0</td> <td>1</td> <td>Complex</td> </tr> <tr> <td>ElectronicAddress (Item 22)</td> <td>0</td> <td>198</td> <td>Complex</td> </tr> <tr> <td>PartyAssociation (Items 24-26)</td> <td>0</td> <td>99</td> <td>Complex</td> </tr> <tr> <td>**PartyAccountAssociation (Items 27)</td> <td>0</td> <td>99</td> <td>Complex</td> </tr> </tbody> </table>					Name	minOccurs	maxOccurs	Content	ActivityPartyTypeCode	1	1	Simple	AdmissionConfessionNoIndicator (Item 23b)	0	1	Simple	AdmissionConfessionYesIndicator (Item 23a)	0	1	Simple	*AllCriticalSubjectInformationUnavailableIndicator(Item 3b)	0	1	Simple	BirthDateUnknownIndicator (Item 19a)	0	1	Simple	BothPurchaserSenderPayeeReceiveIndicator (Item 28c)	0	1	Simple	FemaleGenderIndicator (Item 8b)	0	1	Simple	IndividualBirthDateText (Item 19)	0	1	Simple	MaleGenderIndicator (Item 8a)	0	1	Simple	NoKnownAccountInvolvedIndicator (Item 27a)	0	1	Simple	PartyAsEntityOrganizationIndicator (Item 3a)	0	1	Simple	PayeeReceiverIndicator (Item 28b)	0	1	Simple	PurchaserSenderIndicator (Item 28a)	0	1	Simple	UnknownGenderIndicator (Item 8c)	0	1	Simple	*PartyName (Items 4-7, 9)	1	100	Complex	*Address (Items 11-15)	1	99	Complex	PhoneNumber (Items 20, 21)	0	99	Complex	*PartyIdentification (Items 16-18)	2	100	Complex	PartyOccupationBusiness (Item 10)	0	1	Complex	ElectronicAddress (Item 22)	0	198	Complex	PartyAssociation (Items 24-26)	0	99	Complex	**PartyAccountAssociation (Items 27)	0	99	Complex
Name	minOccurs	maxOccurs	Content																																																																																														
ActivityPartyTypeCode	1	1	Simple																																																																																														
AdmissionConfessionNoIndicator (Item 23b)	0	1	Simple																																																																																														
AdmissionConfessionYesIndicator (Item 23a)	0	1	Simple																																																																																														
*AllCriticalSubjectInformationUnavailableIndicator(Item 3b)	0	1	Simple																																																																																														
BirthDateUnknownIndicator (Item 19a)	0	1	Simple																																																																																														
BothPurchaserSenderPayeeReceiveIndicator (Item 28c)	0	1	Simple																																																																																														
FemaleGenderIndicator (Item 8b)	0	1	Simple																																																																																														
IndividualBirthDateText (Item 19)	0	1	Simple																																																																																														
MaleGenderIndicator (Item 8a)	0	1	Simple																																																																																														
NoKnownAccountInvolvedIndicator (Item 27a)	0	1	Simple																																																																																														
PartyAsEntityOrganizationIndicator (Item 3a)	0	1	Simple																																																																																														
PayeeReceiverIndicator (Item 28b)	0	1	Simple																																																																																														
PurchaserSenderIndicator (Item 28a)	0	1	Simple																																																																																														
UnknownGenderIndicator (Item 8c)	0	1	Simple																																																																																														
*PartyName (Items 4-7, 9)	1	100	Complex																																																																																														
*Address (Items 11-15)	1	99	Complex																																																																																														
PhoneNumber (Items 20, 21)	0	99	Complex																																																																																														
*PartyIdentification (Items 16-18)	2	100	Complex																																																																																														
PartyOccupationBusiness (Item 10)	0	1	Complex																																																																																														
ElectronicAddress (Item 22)	0	198	Complex																																																																																														
PartyAssociation (Items 24-26)	0	99	Complex																																																																																														
**PartyAccountAssociation (Items 27)	0	99	Complex																																																																																														
	<p><i>*In the event that all critical subject information is unavailable, the elements PartyName, Address, and PartyIdentification become minOccurs "0" and should not be recorded; however, if the subject has one or more known alternative names (which is not considered critical information), the PartyName element would be recorded for each known subject alternative name (max 99).</i></p> <p><i>**While Item 27 is associated with the subject, many of the elements associated with this item are reported within the Financial Institution Where Account is Held (41) party type, which is nested within the Subject (33) party type. Please refer to the Party Elements (Account Level) for more details.</i></p>																																																																																																
Attribute(s)	<p>The following attributes must be recorded for this element:</p> <table border="1"> <thead> <tr> <th>Name</th> <th>Description</th> </tr> </thead> <tbody> <tr> <td>SeqNum</td> <td>The value recorded for this attribute must be numeric and unique. It may contain any numeric value up to 19 characters in length.</td> </tr> </tbody> </table>					Name	Description	SeqNum	The value recorded for this attribute must be numeric and unique. It may contain any numeric value up to 19 characters in length.																																																																																								
Name	Description																																																																																																
SeqNum	The value recorded for this attribute must be numeric and unique. It may contain any numeric value up to 19 characters in length.																																																																																																
Parent Element:	Activity																																																																																																
Element Restriction(s):	Required. This element must be recorded.																																																																																																

Element Name:	Party	minOccurs:	6	maxOccurs:	1203																														
	<p>The following table describes the minimum and maximum reporting requirements per FinCEN SAR document by party type (at the activity level):</p> <table border="1"> <thead> <tr> <th>Party type</th> <th>minOccurs</th> <th>maxOccurs</th> </tr> </thead> <tbody> <tr> <td>Transmitter</td> <td>1</td> <td>1</td> </tr> <tr> <td>Transmitter Contact</td> <td>1</td> <td>1</td> </tr> <tr> <td>Filing Institution</td> <td>1</td> <td>1</td> </tr> <tr> <td>Filing Institution Contact Office</td> <td>1</td> <td>1</td> </tr> <tr> <td>Law Enforcement Agency</td> <td>0</td> <td>1</td> </tr> <tr> <td>Law Enforcement Name</td> <td>0</td> <td>1</td> </tr> <tr> <td>Financial Institution Where Activity Occurred</td> <td>1</td> <td>99</td> </tr> <tr> <td>Subject</td> <td>1</td> <td>999</td> </tr> <tr> <td colspan="2" style="text-align: center;"><i>Total (per document)</i></td> <td>1104</td> </tr> </tbody> </table>					Party type	minOccurs	maxOccurs	Transmitter	1	1	Transmitter Contact	1	1	Filing Institution	1	1	Filing Institution Contact Office	1	1	Law Enforcement Agency	0	1	Law Enforcement Name	0	1	Financial Institution Where Activity Occurred	1	99	Subject	1	999	<i>Total (per document)</i>		1104
Party type	minOccurs	maxOccurs																																	
Transmitter	1	1																																	
Transmitter Contact	1	1																																	
Filing Institution	1	1																																	
Filing Institution Contact Office	1	1																																	
Law Enforcement Agency	0	1																																	
Law Enforcement Name	0	1																																	
Financial Institution Where Activity Occurred	1	99																																	
Subject	1	999																																	
<i>Total (per document)</i>		1104																																	
Value Restriction(s):	n/a																																		
Remarks:	<p>The batch submission will be <u>rejected</u> if any of the following conditions are true:</p> <ul style="list-style-type: none"> • The element is not recorded or is incorrectly formatted. • The element is missing a "SeqNum" attribute. • The element contains a "SeqNum" attribute with a duplicate or invalid value. • The following party types are not recorded or exceed the maximum occurrence for the FinCEN SAR: <ul style="list-style-type: none"> ○ Transmitter (1 occurrence) ○ Transmitter Contact (1 occurrence) ○ Filing Institution (1 occurrence) ○ Designated Contact Office (1 occurrence) ○ Financial Institution Where Activity Occurred (no more than 99) ○ Subject (no more than 999) • One or both of the following party types are recorded more than once for the FinCEN SAR: <ul style="list-style-type: none"> ○ Law Enforcement Agency ○ Law Enforcement Name 																																		
Example:	See Part Elements by Party Type for detailed examples...																																		

Element Name:	ActivityPartyTypeCode	minOccurs:	1	maxOccurs:	1																
Description:	Party type (code). This element identifies the type of party associated with the FinCEN SAR.																				
Attribute(s)	n/a																				
Parent Element:	Party																				
Element Restriction(s):	Required. This element must be recorded for each <Party> element regardless of party type.																				
Value Restriction(s):	<p>The value provided must adhere to the following requirements:</p> <table border="1"> <thead> <tr> <th>Code</th> <th>Description</th> </tr> </thead> <tbody> <tr> <td>35</td> <td>Transmitter</td> </tr> <tr> <td>37</td> <td>Transmitter Contact</td> </tr> <tr> <td>30</td> <td>Filing Institution</td> </tr> <tr> <td>8</td> <td>Designated Contact Office</td> </tr> <tr> <td>18</td> <td>Law Enforcement Agency</td> </tr> <tr> <td>19</td> <td>Law Enforcement Name</td> </tr> <tr> <td>34</td> <td>Financial Institution Where Activity Occurred</td> </tr> </tbody> </table>					Code	Description	35	Transmitter	37	Transmitter Contact	30	Filing Institution	8	Designated Contact Office	18	Law Enforcement Agency	19	Law Enforcement Name	34	Financial Institution Where Activity Occurred
Code	Description																				
35	Transmitter																				
37	Transmitter Contact																				
30	Filing Institution																				
8	Designated Contact Office																				
18	Law Enforcement Agency																				
19	Law Enforcement Name																				
34	Financial Institution Where Activity Occurred																				

Element Name:	ActivityPartyTypeCode	minOccurs:	1	maxOccurs:	1
	33 Subject				
Remarks:	The batch submission will be <u>rejected</u> if any of the following conditions are true: <ul style="list-style-type: none"> The element is not recorded. The element is recorded but with no value (i.e. the value is null). The element contains an invalid value. 				
Example:	<fc2:ActivityPartyTypeCode>30</fc2:ActivityPartyTypeCode>				

Element Name:	AdmissionConfessionNoIndicator	minOccurs:	0	maxOccurs:	1
Description:	Corroborative statement to filer: No (indicator). This element declares that the subject individual has made no corroborative statement to the filer. This element corresponds with the following item(s): <ul style="list-style-type: none"> 23b. Corroborative statement to filer (No) <i>Please refer to Attachment C for additional information regarding the above item(s).</i>				
Attribute(s)	n/a				
Parent Element:	Party				
Element Restriction(s):	Record this element when the party type is associated with the Subject (33), the subject is an individual, and the subject made no corroborative statement to the filer admitting to involvement in or otherwise substantiating the suspicious activity; otherwise, do not record this element. Do not record this element if the subject is an entity.				
Value Restriction(s):	The value provided must adhere to the following requirements: "Y" (to indicate "No" to Corroborative statement to filer)				
Remarks:	The batch submission will be <u>rejected</u> if any of the following conditions are true: <ul style="list-style-type: none"> The element is recorded for a party type that is not applicable to this data (see Element Restrictions for more information). The value recorded is not equal to "Y" or not equal to null. 				
Example:	<fc2:AdmissionConfessionNoIndicator>Y</fc2:AdmissionConfessionNoIndicator>				

Element Name:	AdmissionConfessionYesIndicator	minOccurs:	0	maxOccurs:	1
Description:	Corroborative statement to filer: Yes (indicator). This element declares that the subject individual has made a statement to the filer admitting to involvement in or otherwise substantiating the suspicious activity. This element corresponds with the following item(s): <ul style="list-style-type: none"> 23c. Corroborative statement to filer (Yes) <i>Please refer to Attachment C for additional information regarding the above item(s).</i>				
Attribute(s)	n/a				
Parent Element:	Party				
Element Restriction(s):	Record this element when the party type is associated with the Subject (33), the subject is an individual, and the subject has made a statement to the filer admitting to involvement in or otherwise substantiating the suspicious activity; otherwise, do not record this element. Do not record this element if the subject is an entity.				
Value Restriction(s):	The value provided must adhere to the following requirements: "Y" (to indicate "Yes" to Corroborative statement to filer)				
Remarks:	The batch submission will be <u>rejected</u> if any of the following conditions are true: <ul style="list-style-type: none"> The element is recorded for a party type that is not applicable to this data (see Element Restrictions for more information). The value recorded is not equal to "Y" or not equal to null. 				
Example:	<fc2:AdmissionConfessionYesIndicator>Y</fc2:AdmissionConfessionYesIndicator>				

Element Name:	AllCriticalSubjectInformationUnavailableIndicator	minOccurs:	0	maxOccurs:	1
Description:	<p>All critical subject information unavailable (indicator). This element declares that all critical subject information is unavailable. This element corresponds with the following item(s):</p> <ul style="list-style-type: none"> 3b. Check if all critical* subject information is unavailable (does not include item *27) <p><i>Please refer to Attachment C for additional information regarding the above item(s).</i></p>				
Attribute(s)	n/a				
Parent Element:	Party				
Element Restriction(s):	<p>Record this element when the party type is associated with the Subject (33) and all critical* subject information is unavailable with the exception of Item 27 "Financial Institution TIN and account number(s) affected that are related to the subject"; otherwise, do not record this element.</p> <p>*Refer to Attachment C (Item Instructions) to identify all critical items associated with the subject.</p>				
Value Restriction(s):	The value provided must adhere to the following requirements: "Y" (to indicate "All critical subject information unavailable")				
Remarks:	<p>The batch submission will be <u>rejected</u> if any of the following conditions are true:</p> <ul style="list-style-type: none"> The element is recorded for a party type that is not applicable to this data (see Element Restrictions for more information). The value recorded is not equal to "Y" or not equal to null. 				
Example:	<fc2:AllCriticalSubjectInformationUnavailableIndicator>Y</fc2:AllCriticalSubjectInformationUnavailableIndicator>				

Element Name:	BirthDateUnknownIndicator	minOccurs:	0	maxOccurs:	1
Description:	<p>Date of birth (date). This element identifies the date of birth associated with the subject. This element corresponds with the following item(s):</p> <ul style="list-style-type: none"> 19a. Date of birth (unknown) <p><i>Please refer to Attachment C for additional information regarding the above item(s).</i></p>				
Attribute(s)	n/a				
Parent Element:	Party				
Element Restriction(s):	<p>Record this element when the party type is associated with the Subject (33), the subject is an individual, and the date of birth is unknown*; otherwise, do not record this element.</p> <p>*If the subject is an individual and the date of birth is known, record the <IndividualBirthDateText> element with the birth date and do not record the <BirthDateUnknownIndicator> element.</p>				
Value Restriction(s):	The value provided must adhere to the following requirements: "Y" (to indicate date of birth unknown)				
Remarks:	<p>The batch submission will be <u>rejected</u> if any of the following conditions are true:</p> <ul style="list-style-type: none"> The element is recorded for a party type that is not applicable to this data (see Element Restrictions for more information). The value recorded is not equal to "Y" or not equal to null. 				
Example:	<fc2:BirthDateUnknownIndicator>Y</fc2:BirthDateUnknownIndicator>				

Element Name:	BothPurchaserSenderPayeeReceiveIndicator	minOccurs:	0	maxOccurs:	1
Description:	<p>This element declares that the subject was both a purchaser/sender of the financial instrument(s) or product(s) involved in the suspicious activity and payee/receiver of the instrument(s) or product(s) involved in the suspicious activity. This element corresponds with the following item(s):</p> <ul style="list-style-type: none"> 28c. Subject's role in suspicious activity (both Purchaser/Sender and Payee/Receiver) <p><i>Please refer to Attachment C for additional information regarding the above item(s).</i></p>				
Attribute(s)	n/a				
Parent Element:	Party				

Element Name:	BothPurchaserSenderPayeeReceiveIndicator	minOccurs:	0	maxOccurs:	1
Element Restriction(s):	Record this element when the party type is associated with the Subject (33) and the subject was both the payee/receiver and purchaser/sender of the instrument(s) or product(s) involved in the suspicious activity; otherwise, do not record this element.				
Value Restriction(s):	The value provided must adhere to the following requirements: "Y" (to indicate both Purchaser/Sender and Payee/Receiver)				
Remarks:	<p>The batch submission will be <u>rejected</u> if any of the following conditions are true:</p> <ul style="list-style-type: none"> The element is recorded for a party type that is not applicable to this data (see Element Restrictions for more information). The value recorded is not equal to "Y" or not equal to null. <p>The batch submission will be <u>accepted with warning</u> if any of the following conditions are true:</p> <ul style="list-style-type: none"> More than one role is recorded for the Subject. 				
Example:	<fc2:BothPurchaserSenderPayeeReceiveIndicator>Y</fc2:BothPurchaserSenderPayeeReceiveIndicator>				

Element Name:	ContactDateText	minOccurs:	0	maxOccurs:	1
Description:	<p>Law enforcement contact date (date). This element identifies the most-recent date the law enforcement agency was contacted about the suspicious activity. This element corresponds with the following item(s):</p> <ul style="list-style-type: none"> 92. LE contact date <p><i>Please refer to Attachment C for additional information regarding the above item(s).</i></p>				
Attribute(s)	n/a				
Parent Element:	Party				
Element Restriction(s):	Record this element when the party type is associated with the LE Contact Name (19) and the most-recent date the law enforcement agency was contacted about the suspicious activity is available; otherwise, do not record this element.				
Value Restriction(s):	The value provided must adhere to the following requirements: 8 numeric characters in the format YYYYMMDD where YYYY = year, MM = month, and DD = day. Single digit days or months must be prefaced by a zero.				
Remarks:	<p>The batch submission will be <u>rejected</u> if any of the following conditions are true:</p> <ul style="list-style-type: none"> The element is recorded for a party type that is not applicable to this data (see Element Restrictions for more information). The value recorded for the element is not in the required format (YYYYMMDD). 				
Example:	<fc2:ContactDateText>20171105</fc2:ContactDateText>				

Element Name:	FemaleGenderIndicator	minOccurs:	0	maxOccurs:	1
Description:	<p>Gender: Female (indicator). This element declares that the gender of the subject is female. This element corresponds with the following item(s):</p> <ul style="list-style-type: none"> 8b. Gender (female) <p><i>Please refer to Attachment C for additional information regarding the above item(s).</i></p>				
Attribute(s)	n/a				
Parent Element:	Party				
Element Restriction(s):	Record this element when the party type is associated with the Subject (33), the subject is an individual, and subject's gender is female; if the subject's gender is male or unknown, or the subject is an entity, do not record this element.				
Value Restriction(s):	The value provided must adhere to the following requirements: "Y" (to indicate female gender)				
Remarks:	<p>The batch submission will be <u>rejected</u> if any of the following conditions are true:</p> <ul style="list-style-type: none"> The element is recorded for a party type that is not applicable to this data (see Element Restrictions for more information). The value recorded is not equal to "Y" or not equal to null. 				

Element Name:	FemaleGenderIndicator	minOccurs:	0	maxOccurs:	1
Description:	The batch submission will be <u>accepted with warnings</u> if any of the following conditions are true: <ul style="list-style-type: none"> • More than one gender is recorded for the Subject. • The gender is not specified for the individual Subject. • The gender "female" is specified for the entity Subject. 				
Example:	<fc2:FemaleGenderIndicator>Y</fc2:FemaleGenderIndicator>				

Element Name:	IndividualBirthDateText	minOccurs:	0	maxOccurs:	1
Description:	Date of birth unknown (indicator). This element declares that the date of birth associated with the subject is unknown. This element corresponds with the following item(s): <ul style="list-style-type: none"> • 19. Date of birth <i>Please refer to Attachment C for additional information regarding the above item(s).</i>				
Attribute(s)	n/a				
Parent Element:	Party				
Element Restriction(s):	Record this element when the party type is associated with the Subject (33), the subject is an individual, and the date of birth is known*; otherwise, do not record this element. *If the subject is an individual and the date of birth is unknown, record the <BirthDateUnknownIndicator> element with a "Y" value and do not record the <IndividualBirthDateText> element.				
Value Restriction(s):	The value provided must adhere to the following requirements: 8 numeric characters in the format YYYYMMDD where YYYY = year, MM = month, and DD = day. Single digit days or months must be prefaced by a zero. If the birth day and/or month is unknown, enter "00" for the unknown day or month. For example, a date of birth with an unknown day in February 1978 would be entered as 19780200. Do not enter zeros for the year if the year is unknown.				
Remarks:	The batch submission will be <u>rejected</u> if any of the following conditions are true: <ul style="list-style-type: none"> • The element is recorded for a party type that is not applicable to this data (see Element Restrictions for more information). The batch submission will be <u>accepted with warning</u> if any of the following conditions are true: <ul style="list-style-type: none"> • The value recorded for the element is not in the required format (YYYYMMDD). • The element is not recorded for the individual Subject and both <AllCriticalSubjectInformationUnavailableIndicator> or <BirthDateUnknownIndicator> do not contain a "Y" value. • The date of birth recorded is less than January 1, 1900. 				
Example:	<fc2:IndividualBirthDateText>19801025</fc2:IndividualBirthDateText>				

Element Name:	LossToFinancialAmountText	minOccurs:	0	maxOccurs:	1
Description:	Loss to financial institution (amount). This element identifies the dollar amount loss to the financial institution because of the suspicious activity. This element corresponds with the following item(s): <ul style="list-style-type: none"> • 67. Loss to financial institution (if applicable) <i>Please refer to Attachment C for additional information regarding the above item(s).</i>				
Attribute(s)	n/a				
Parent Element:	Party				
Element Restriction(s):	Record this element when the party type is associated with the Financial institution where activity occurred (34) and the institution has suffered a loss as a result of the suspicious activity; otherwise, do not record this element.				
Value Restriction(s):	The value provided must adhere to the following requirements: 1-15 numeric characters (without leading zeros) denominated in whole U.S. Dollars. The amount entered in this element cannot be zero and cannot be greater than the amount recorded in the <TotalSuspiciousAmountText> element. Do not include non-numeric characters.				

Element Name:	LossToFinancialAmountText	minOccurs:	0	maxOccurs:	1
	NOTE: If some losses are known and other losses unknown, enter the total of known losses as of the date of filing. If the FinCEN SAR is a continuing activity report, enter in the <LossToFinancialAmountText> element the loss amount for the current FinCEN SAR and record in the narrative the total aggregated losses for all FinCEN SARs filed on the suspicious activity.				
Remarks:	<p>The batch submission will be <u>rejected</u> if any of the following conditions are true:</p> <ul style="list-style-type: none"> The element is recorded for a party type that is not applicable to this data (see Element Restrictions for more information). <p>The batch submission will be <u>accepted with warning</u> if any of the following conditions are true:</p> <ul style="list-style-type: none"> The amount recorded contains one or more non-numeric characters. The amount recorded is equal to zero. The amount recorded is greater than the amount involved in the report. 				
Example:	<fc2:LossToFinancialAmountText>15000</fc2:LossToFinancialAmountText>				

Element Name:	MaleGenderIndicator	minOccurs:	0	maxOccurs:	1
Description:	Gender: Male (indicator). This element declares that the gender of the subject is male. This element corresponds with the following item(s):				
	<ul style="list-style-type: none"> 8a. Gender (male) <p><i>Please refer to Attachment C for additional information regarding the above item(s).</i></p>				
Attribute(s)	n/a				
Parent Element:	Party				
Element Restriction(s):	Record this element when the party type is associated with the Subject (33), the subject is an individual, and subject's gender is male; if the subject's gender is female or unknown, or the subject is an entity, do not record this element.				
Value Restriction(s):	The value provided must adhere to the following requirements: "Y" (to indicate male gender)				
Remarks:	<p>The batch submission will be <u>rejected</u> if any of the following conditions are true:</p> <ul style="list-style-type: none"> The element is recorded for a party type that is not applicable to this data (see Element Restrictions for more information). The value recorded is not equal to "Y" or not equal to null. <p>The batch submission will be <u>accepted with warnings</u> if any of the following conditions are true:</p> <ul style="list-style-type: none"> More than one gender is recorded for the Subject. The gender is not specified for the individual Subject. The gender "male" is specified for the entity Subject. 				
Example:	<fc2:MaleGenderIndicator>Y</fc2:MaleGenderIndicator>				

Element Name:	NoBranchActivityInvolvedIndicator	minOccurs:	0	maxOccurs:	1
Description:	No branch involved (indicator). This element declares that there is no branch location involved in the suspicious activity for the associated financial institution where activity occurred. This element corresponds with the following item(s):				
	<ul style="list-style-type: none"> 69a. No branch activity involved <p><i>Please refer to Attachment C for additional information regarding the above item(s).</i></p>				
Attribute(s)	n/a				
Parent Element:	Party				
Element Restriction(s):	Record this element when the party type is associated with the Financial Institution Where Activity Occurred (34) and no branch was involved in the suspicious activity (or the branch country is unknown); otherwise, do not record this element. If this element is recorded, do not record a party type associated with the Branch Where Activity Occurred (46) for the associated Financial Institution (34).				
Value Restriction(s):	The value provided must adhere to the following requirements: "Y" (to indicate "No branch activity involved")				

Element Name:	NoBranchActivityInvolvedIndicator	minOccurs:	0	maxOccurs:	1
Remarks:	<p>The batch submission will be <u>rejected</u> if any of the following conditions are true:</p> <ul style="list-style-type: none"> The element is recorded for a party type that is not applicable to this data (see Element Restrictions for more information). The value recorded is not equal to "Y" or not equal to null. <p>The batch submission will be <u>accepted with warnings</u> if any of the following conditions are true:</p> <ul style="list-style-type: none"> This element is recorded with a "Y" value for the Financial institution (34) but one or more Branch (46) party type locations are also recorded. The party type associated with the branch where activity occurred is not recorded and "no branch activity involved" is not indicated. 				
Example:	<fc2:NoBranchActivityInvolvedIndicator>Y</fc2:NoBranchActivityInvolvedIndicator>				

Element Name:	NoKnownAccountInvolvedIndicator	minOccurs:	0	maxOccurs:	1
Description:	<p>No known account involved (indicator). This element declares that no account related to the subject is involved in the suspicious activity. This element corresponds with the following item(s):</p> <ul style="list-style-type: none"> 27a. No known account involved <p><i>Please refer to Attachment C for additional information regarding the above item(s).</i></p>				
Attribute(s)	n/a				
Parent Element:	Party				
Element Restriction(s):	Record this element when the party type is associated with the Subject (33) and no account related to the subject is involved in the suspicious activity; otherwise, do not record this element.				
Value Restriction(s):	The value provided must adhere to the following requirements: "Y" (to indicate "No known account involved")				
Remarks:	<p>The batch submission will be <u>rejected</u> if any of the following conditions are true:</p> <ul style="list-style-type: none"> The element is recorded for a party type that is not applicable to this data (see Element Restrictions for more information). The value recorded is not equal to "Y" or not equal to null. <p>The batch submission will be accepted with warning if any of the following conditions are true:</p> <ul style="list-style-type: none"> The element is recorded with a "Y" value and the <PartyAccountAssociation> element is also recorded. The element is not recorded and the <PartyAccountAssociation element is also not recorded. 				
Example:	<fc2:NoKnownAccountInvolvedIndicator>Y</fc2:NoKnownAccountInvolvedIndicator>				

Element Name:	PartyAsEntityOrganizationIndicator	minOccurs:	0	maxOccurs:	1
Description:	<p>Entity (indicator). This element declares that the subject is an entity. This element corresponds with the following item(s):</p> <ul style="list-style-type: none"> 3a. Check if entity <p><i>Please refer to Attachment C for additional information regarding the above item(s).</i></p>				
Attribute(s)	n/a				
Parent Element:	Party				
Element Restriction(s):	Record this element when the party type is associated with the Subject (33) and the subject is an entity; otherwise, do not record this element.				
Value Restriction(s):	The value provided must adhere to the following requirements: "Y" (to indicate that the subject is an entity)				
Remarks:	<p>The batch submission will be <u>rejected</u> if any of the following conditions are true:</p> <ul style="list-style-type: none"> The element is recorded for a party type that is not applicable to this data (see Element Restrictions for more information). The value recorded is not equal to "Y" or not equal to null. 				
Example:	<fc2:PartyAsEntityOrganizationIndicator>Y</fc2:PartyAsEntityOrganizationIndicator>				

Element Name:	PayeeReceiverIndicator	minOccurs:	0	maxOccurs:	1
Description:	Payee/Receiver (indicator). This element declares that the subject was the payee or receiver of the instrument(s) or product(s). This element corresponds with the following item(s): <ul style="list-style-type: none"> 28b. Subject's role in suspicious activity (Payee/Receiver) <i>Please refer to Attachment C for additional information regarding the above item(s).</i>				
Attribute(s)	n/a				
Parent Element:	Party				
Element Restriction(s):	Record this element when the party type is associated with the Subject (33) and the subject was the payee or receiver of the instrument(s) or product(s) involved in the suspicious activity; otherwise, do not record this element.				
Value Restriction(s):	The value provided must adhere to the following requirements: "Y" (to indicate Payee/Receiver)				
Remarks:	The batch submission will be <u>rejected</u> if any of the following conditions are true: <ul style="list-style-type: none"> The element is recorded for a party type that is not applicable to this data (see Element Restrictions for more information). The value recorded is not equal to "Y" or not equal to null. The batch submission will be <u>accepted with warning</u> if any of the following conditions are true: <ul style="list-style-type: none"> More than one role is recorded for the Subject. 				
Example:	<fc2:PayeeReceiverIndicator>Y</fc2:PayeeReceiverIndicator>				

Element Name:	PayLocationIndicator	minOccurs:	0	maxOccurs:	1
Description:	Paying location (indicator). This element declares that the customer received payment from the financial institution where activity occurred for the products or instruments recorded in the FinCEN SAR. This element corresponds with the following item(s): <ul style="list-style-type: none"> 56b. Financial institution's role in transaction (Paying location) <i>Please refer to Attachment C for additional information regarding the above item(s).</i>				
Attribute(s)	n/a				
Parent Element:	Party				
Element Restriction(s):	Record this element when the party type is associated with the Financial Institution Where Activity Occurred (34) and the customer received payment from the Financial Institution (34) for the recorded products or instruments; otherwise, do not record this element.				
Value Restriction(s):	The value provided must adhere to the following requirements: "Y" (to indicate "Paying location")				
Remarks:	The batch submission will be <u>rejected</u> if any of the following conditions are true: <ul style="list-style-type: none"> The element is recorded for a party type that is not applicable to this data (see Element Restrictions for more information). The value recorded is not equal to "Y" or not equal to null. 				
Example:	<fc2:PayLocationIndicator>Y</fc2:PayLocationIndicator>				

Element Name:	PrimaryRegulatorTypeCode	minOccurs:	0	maxOccurs:	1
Description:	Primary regulator type (code). This element identifies the primary federal regulator or BSA examiner of the financial institution where activity occurred as well as the filing institution. This element corresponds with the following item(s): <ul style="list-style-type: none"> Financial Institution Where Activity Occurred: 52. Primary Federal Regulator Filing Institution: 75. Primary Federal Regulator <i>Please refer to Attachment C for additional information regarding the above item(s).</i>				
Attribute(s)	n/a				
Parent Element:	Party				

Element Name:	PrimaryRegulatorTypeCode	minOccurs:	0	maxOccurs:	1																				
Element Restriction(s):	Conditionally Required. This element must be recorded for the following party types; otherwise, do not record this element: <ul style="list-style-type: none"> Financial Institution Where Activity Occurred (34) Filing Institution (30) 																								
Value Restriction(s):	The value provided must adhere to the following requirements: <table border="1" style="margin-left: 20px;"> <thead> <tr> <th>Code</th> <th>Description</th> </tr> </thead> <tbody> <tr> <td>9</td> <td>CFTC (Commodities Futures Trading Commission)</td> </tr> <tr> <td>1</td> <td>Federal Reserve</td> </tr> <tr> <td>2</td> <td>FDIC (Federal Deposit Insurance Corporation)</td> </tr> <tr> <td>13</td> <td>FHFA (Federal Housing Finance Agency)</td> </tr> <tr> <td>7</td> <td>IRS (Internal Revenue Service)</td> </tr> <tr> <td>3</td> <td>NCUA (National Credit Union Administration)</td> </tr> <tr> <td>4</td> <td>OCC (Office of the Comptroller of the Currency)</td> </tr> <tr> <td>6</td> <td>SEC (Securities and Exchange Commission)</td> </tr> <tr> <td>99</td> <td>Not Applicable</td> </tr> </tbody> </table>					Code	Description	9	CFTC (Commodities Futures Trading Commission)	1	Federal Reserve	2	FDIC (Federal Deposit Insurance Corporation)	13	FHFA (Federal Housing Finance Agency)	7	IRS (Internal Revenue Service)	3	NCUA (National Credit Union Administration)	4	OCC (Office of the Comptroller of the Currency)	6	SEC (Securities and Exchange Commission)	99	Not Applicable
Code	Description																								
9	CFTC (Commodities Futures Trading Commission)																								
1	Federal Reserve																								
2	FDIC (Federal Deposit Insurance Corporation)																								
13	FHFA (Federal Housing Finance Agency)																								
7	IRS (Internal Revenue Service)																								
3	NCUA (National Credit Union Administration)																								
4	OCC (Office of the Comptroller of the Currency)																								
6	SEC (Securities and Exchange Commission)																								
99	Not Applicable																								
Remarks:	The batch submission will be <u>rejected</u> if any of the following conditions are true: <ul style="list-style-type: none"> The element is recorded for a party type that is not applicable to this data (see Element Restrictions for more information). The element is not recorded for the approved party type (see Element Restrictions for more information). The element is recorded but with no value (i.e. the value is null). The element contains an invalid value. 																								
Example:	<fc2:PrimaryRegulatorTypeCode>4</fc2:PrimaryRegulatorTypeCode>																								

Element Name:	PurchaserSenderIndicator	minOccurs:	0	maxOccurs:	1
Description:	Purchaser/Sender (indicator). This element declares that the subject purchased or sent the financial instrument(s) or product(s) involved in the suspicious activity. This element corresponds with the following item(s): <ul style="list-style-type: none"> 28a. Subject's role in suspicious activity (Purchaser/Sender) <i>Please refer to Attachment C for additional information regarding the above item(s).</i>				
Attribute(s)	n/a				
Parent Element:	Party				
Element Restriction(s):	Record this element when the party type is associated with the Subject (33) and the subject purchased or sent the financial instrument(s) or product(s) involved in the suspicious activity; otherwise, do not record this element.				
Value Restriction(s):	The value provided must adhere to the following requirements: "Y" (to indicate Purchaser/Sender)				
Remarks:	The batch submission will be <u>rejected</u> if any of the following conditions are true: <ul style="list-style-type: none"> The element is recorded for a party type that is not applicable to this data (see Element Restrictions for more information). The value recorded is not equal to "Y" or not equal to null. The batch submission will be <u>accepted with warning</u> if any of the following conditions are true: <ul style="list-style-type: none"> More than one role is recorded for the Subject. 				
Example:	<fc2:PurchaserSenderIndicator>Y</fc2:PurchaserSenderIndicator>				

Element Name:	SellingLocationIndicator	minOccurs:	0	maxOccurs:	1
Description:	Selling location (indicator). This element declares that the customer purchased at the financial institution where activity occurred the products or instruments recorded in the FinCEN SAR. This element corresponds with the following item(s): <ul style="list-style-type: none"> 56a. Financial Institution's role in transaction: Selling location <i>Please refer to Attachment C for additional information regarding the above item(s).</i>				
Attribute(s)	n/a				
Parent Element:	Party				
Element Restriction(s):	Record this element when the party type is associated with the Financial Institution Where Activity Occurred (34) and the customer purchased at the financial institution (34) the recorded products or instruments; otherwise, do not record this element.				
Value Restriction(s):	The value provided must adhere to the following requirements: "Y" (to indicate "Selling location")				
Remarks:	The batch submission will be <u>rejected</u> if any of the following conditions are true: <ul style="list-style-type: none"> The element is recorded for a party type that is not applicable to this data (see Element Restrictions for more information). The value recorded is not equal to "Y" or not equal to null. 				
Example:	<fc2:SellingLocationIndicator>Y</fc2:SellingLocationIndicator>				

Element Name:	SellingPayingLocationIndicator	minOccurs:	0	maxOccurs:	1
Description:	Selling and Paying location (indicator). This element declares that the financial institution where activity occurred was both a paying and selling location for the products or instruments recorded in the FinCEN SAR. This element corresponds with the following item(s): <ul style="list-style-type: none"> 56c. Financial Institution's role in transaction: Both Selling and Paying location <i>Please refer to Attachment C for additional information regarding the above item(s).</i>				
Attribute(s)	n/a				
Parent Element:	Party				
Element Restriction(s):	Record this element when the party type is associated with the Financial Institution Where Activity Occurred (34) and the financial institution was both the selling and paying location for the recorded products or instruments; otherwise, do not record this element.				
Value Restriction(s):	The value provided must adhere to the following requirements: "Y" (to indicate both Selling and Paying location)				
Remarks:	The batch submission will be <u>rejected</u> if any of the following conditions are true: <ul style="list-style-type: none"> The element is recorded for a party type that is not applicable to this data (see Element Restrictions for more information). The value recorded is not equal to "Y" or not equal to null. 				
Example:	<fc2:SellingPayingLocationIndicator>Y</fc2:SellingPayingLocationIndicator>				

Element Name:	UnknownGenderIndicator	minOccurs:	0	maxOccurs:	1
Description:	Gender: Unknown (indicator). This element declares that the gender of the subject is unknown. This element corresponds with the following item(s): <ul style="list-style-type: none"> 8c. Gender (unknown) <i>Please refer to Attachment C for additional information regarding the above item(s).</i>				
Attribute(s)	n/a				
Parent Element:	Party				
Element Restriction(s):	Record this element when the party type is associated with the Subject (33), the subject is an individual, and subject's gender is unknown; if the subject's gender is known, or the subject is an entity, do not record this element.				

Element Name:	UnknownGenderIndicator	minOccurs:	0	maxOccurs:	1
Value Restriction(s):	The value provided must adhere to the following requirements: "Y" (to indicate unknown gender)				
Remarks:	<p>The batch submission will be <u>rejected</u> if any of the following conditions are true:</p> <ul style="list-style-type: none"> The element is recorded for a party type that is not applicable to this data (see Element Restrictions for more information). The value recorded is not equal to "Y" or not equal to null. <p>The batch submission will be <u>accepted with warnings</u> if any of the following conditions are true:</p> <ul style="list-style-type: none"> More than one gender is recorded for the Subject. The gender is not specified for the individual Subject. The gender "unknown" is specified for the entity Subject. 				
Example:	<fc2:UnknownGenderIndicator>Y</fc2:UnknownGenderIndicator>				

Element Name:	PartyName	See <i>PartyName Elements</i> for details.
---------------	-----------	--

Element Name:	Address	See <i>Address Elements</i> for details.
---------------	---------	--

Element Name:	PhoneNumber	See <i>PhoneNumber Elements</i> for details.
---------------	-------------	--

Element Name:	PartyIdentification	See <i>PartyIdentification Elements</i> for details.
---------------	---------------------	--

Element Name:	OrganizationClassificationTypeSubtype	See <i>OrganizationClassificationTypeSubtype Elements</i> for details.
---------------	---------------------------------------	--

Element Name:	PartyOccupationBusiness	See <i>PartyOccupationBusiness Elements</i> for details.
---------------	-------------------------	--

Element Name:	ElectronicAddress	See <i>ElectronicAddress Elements</i> for details.
---------------	-------------------	--

Element Name:	PartyAssociation	See <i>PartyAssociation Elements</i> for details.
---------------	------------------	---

Element Name:	PartyAccountAssociation	See <i>PartyAccountAssociation Elements</i> for details.
---------------	-------------------------	--

4.6.1. PartyName Elements

Element Name:	PartyName	minOccurs:	0	maxOccurs:	100
Description:	Party name (header). This is the container for information about the name of the party. The party name can be a legal name, doing business as (DBA) name, or also known as (AKA) name depending on the party type identified.				

Element Name:	PartyName	minOccurs:	0	maxOccurs:	100																																																																																				
<p>The following sub-element is associated with this element:</p> <div style="background-color: #e1f5fe; padding: 10px; text-align: center;"> <p>Activity party type code definitions</p> <p>35 = Transmitter 37 = Transmitter Contact 30 = Filing Institution 8 = Contact Office 18 = LE Contact Agency 19 = LE Contact Name 34 = Financial Institution Where Activity Occurred 33 = Subject</p> </div> <ol style="list-style-type: none"> 1. Transmitter Information: Legal name (Required) <table border="1" style="width: 100%; border-collapse: collapse;"> <thead> <tr> <th style="background-color: #e1f5fe;">Name</th> <th>minOccurs</th> <th>maxOccurs</th> <th>Content</th> </tr> </thead> <tbody> <tr> <td>PartyNameTypeCode (Code L)</td> <td style="text-align: center;">1</td> <td style="text-align: center;">1</td> <td>Simple</td> </tr> <tr> <td>RawPartyFullName</td> <td style="text-align: center;">1</td> <td style="text-align: center;">1</td> <td>Simple</td> </tr> </tbody> </table> 2. Transmitter Contact Information: Legal name (Required) <table border="1" style="width: 100%; border-collapse: collapse;"> <thead> <tr> <th style="background-color: #e1f5fe;">Name</th> <th>minOccurs</th> <th>maxOccurs</th> <th>Content</th> </tr> </thead> <tbody> <tr> <td>PartyNameTypeCode (Code L)</td> <td style="text-align: center;">1</td> <td style="text-align: center;">1</td> <td>Simple</td> </tr> <tr> <td>RawPartyFullName</td> <td style="text-align: center;">1</td> <td style="text-align: center;">1</td> <td>Simple</td> </tr> </tbody> </table> 3. Filing Institution Information: <ol style="list-style-type: none"> a. Legal name (Required FinCEN SAR Part IV, Items 76) <table border="1" style="width: 100%; border-collapse: collapse;"> <thead> <tr> <th style="background-color: #e1f5fe;">Name</th> <th>minOccurs</th> <th>maxOccurs</th> <th>Content</th> </tr> </thead> <tbody> <tr> <td>PartyNameTypeCode (Code L)</td> <td style="text-align: center;">1</td> <td style="text-align: center;">1</td> <td>Simple</td> </tr> <tr> <td>RawPartyFullName (Item 76)</td> <td style="text-align: center;">1</td> <td style="text-align: center;">1</td> <td>Simple</td> </tr> </tbody> </table> b. Alternate name (if applicable FinCEN SAR Part IV, Item 87) <table border="1" style="width: 100%; border-collapse: collapse;"> <thead> <tr> <th style="background-color: #e1f5fe;">Name</th> <th>minOccurs</th> <th>maxOccurs</th> <th>Content</th> </tr> </thead> <tbody> <tr> <td>PartyNameTypeCode (Code AKA or DBA)</td> <td style="text-align: center;">1</td> <td style="text-align: center;">1</td> <td>Simple</td> </tr> <tr> <td>RawPartyFullName (Item 87)</td> <td style="text-align: center;">1</td> <td style="text-align: center;">1</td> <td>Simple</td> </tr> </tbody> </table> 4. Contact Office: Legal name (Required FinCEN SAR Part IV, Items 93) <table border="1" style="width: 100%; border-collapse: collapse;"> <thead> <tr> <th style="background-color: #e1f5fe;">Name</th> <th>minOccurs</th> <th>maxOccurs</th> <th>Content</th> </tr> </thead> <tbody> <tr> <td>PartyNameTypeCode (Code L)</td> <td style="text-align: center;">1</td> <td style="text-align: center;">1</td> <td>Simple</td> </tr> <tr> <td>RawPartyFullName (Item 93)</td> <td style="text-align: center;">1</td> <td style="text-align: center;">1</td> <td>Simple</td> </tr> </tbody> </table> 5. LE Contact Agency: Legal name (if applicable FinCEN SAR Part IV, Item 89) <table border="1" style="width: 100%; border-collapse: collapse;"> <thead> <tr> <th style="background-color: #e1f5fe;">Name</th> <th>minOccurs</th> <th>maxOccurs</th> <th>Content</th> </tr> </thead> <tbody> <tr> <td>PartyNameTypeCode (Code L)</td> <td style="text-align: center;">1</td> <td style="text-align: center;">1</td> <td>Simple</td> </tr> <tr> <td>RawPartyFullName (Item 89)</td> <td style="text-align: center;">1</td> <td style="text-align: center;">1</td> <td>Simple</td> </tr> </tbody> </table> 6. LE Contact Name: Legal name (if applicable FinCEN SAR Part IV, Items 90) <table border="1" style="width: 100%; border-collapse: collapse;"> <thead> <tr> <th style="background-color: #e1f5fe;">Name</th> <th>minOccurs</th> <th>maxOccurs</th> <th>Content</th> </tr> </thead> <tbody> <tr> <td>PartyNameTypeCode (Code L)</td> <td style="text-align: center;">1</td> <td style="text-align: center;">1</td> <td>Simple</td> </tr> <tr> <td>RawPartyFullName (Item 90)</td> <td style="text-align: center;">1</td> <td style="text-align: center;">1</td> <td>Simple</td> </tr> </tbody> </table> 7. Financial Institution Where Activity Occurred: <ol style="list-style-type: none"> a. Legal name/unknown (Required FinCEN SAR Part III, Item 57) 						Name	minOccurs	maxOccurs	Content	PartyNameTypeCode (Code L)	1	1	Simple	RawPartyFullName	1	1	Simple	Name	minOccurs	maxOccurs	Content	PartyNameTypeCode (Code L)	1	1	Simple	RawPartyFullName	1	1	Simple	Name	minOccurs	maxOccurs	Content	PartyNameTypeCode (Code L)	1	1	Simple	RawPartyFullName (Item 76)	1	1	Simple	Name	minOccurs	maxOccurs	Content	PartyNameTypeCode (Code AKA or DBA)	1	1	Simple	RawPartyFullName (Item 87)	1	1	Simple	Name	minOccurs	maxOccurs	Content	PartyNameTypeCode (Code L)	1	1	Simple	RawPartyFullName (Item 93)	1	1	Simple	Name	minOccurs	maxOccurs	Content	PartyNameTypeCode (Code L)	1	1	Simple	RawPartyFullName (Item 89)	1	1	Simple	Name	minOccurs	maxOccurs	Content	PartyNameTypeCode (Code L)	1	1	Simple	RawPartyFullName (Item 90)	1	1	Simple
Name	minOccurs	maxOccurs	Content																																																																																						
PartyNameTypeCode (Code L)	1	1	Simple																																																																																						
RawPartyFullName	1	1	Simple																																																																																						
Name	minOccurs	maxOccurs	Content																																																																																						
PartyNameTypeCode (Code L)	1	1	Simple																																																																																						
RawPartyFullName	1	1	Simple																																																																																						
Name	minOccurs	maxOccurs	Content																																																																																						
PartyNameTypeCode (Code L)	1	1	Simple																																																																																						
RawPartyFullName (Item 76)	1	1	Simple																																																																																						
Name	minOccurs	maxOccurs	Content																																																																																						
PartyNameTypeCode (Code AKA or DBA)	1	1	Simple																																																																																						
RawPartyFullName (Item 87)	1	1	Simple																																																																																						
Name	minOccurs	maxOccurs	Content																																																																																						
PartyNameTypeCode (Code L)	1	1	Simple																																																																																						
RawPartyFullName (Item 93)	1	1	Simple																																																																																						
Name	minOccurs	maxOccurs	Content																																																																																						
PartyNameTypeCode (Code L)	1	1	Simple																																																																																						
RawPartyFullName (Item 89)	1	1	Simple																																																																																						
Name	minOccurs	maxOccurs	Content																																																																																						
PartyNameTypeCode (Code L)	1	1	Simple																																																																																						
RawPartyFullName (Item 90)	1	1	Simple																																																																																						

Element Name:	PartyName	minOccurs:	0	maxOccurs:	100				
	Name		minOccurs	maxOccurs	Content				
	EntityLastNameUnknownIndicator (Code Y)		0	1	Simple				
	PartyNameTypeCode (Code L)		1	1	Simple				
	RawPartyFullName (Item 57)		0	1	Simple				
	<p><i>*If unknown is indicated, the corresponding element whose value is unknown should not be recorded; otherwise, the unknown indicator element should not be recorded.</i></p> <p>b. Alternate name (if applicable FinCEN SAR Part III, Item 58)</p>								
	Name		minOccurs	maxOccurs	Content				
	PartyNameTypeCode (Code AKA or DBA)		1	1	Simple				
	RawPartyFullName (Item 58)		1	1	Simple				
	<p>8. Subject</p> <p>a. Legal name/unknown (Conditionally Required FinCEN SAR Part I, Items 4-7)</p>								
	Name		minOccurs	maxOccurs	Content				
	EntityLastNameUnknownIndicator (Item 4a)		0	1	Simple				
	FirstNameUnknownIndicator (Item 5a)		0	1	Simple				
	PartyNameTypeCode (Code L)		1	1	Simple				
	RawEntityIndividualLastName (Item 4)		0	1	Simple				
	RawIndividualFirstName (Item 5)		0	1	Simple				
	RawIndividualMiddleName (Item 6)		0	1	Simple				
	RawIndividualNameSuffixText (Item 7)		0	1	Simple				
	<p><i>*If unknown is indicated, the corresponding element whose value is unknown should not be recorded; otherwise, the unknown indicator element should not be recorded. In the event that all critical subject information is unavailable, do not record the <PartyName> element for the Subject (33) unless recording the subjects alternative name (if known).</i></p> <p>b. Alternate name (if applicable FinCEN SAR Part I, Item 9)</p>								
	Name		minOccurs	maxOccurs	Content				
	PartyNameTypeCode (Code AKA or DBA)		1	1	Simple				
	RawPartyFullName (Item 58)		1	1	Simple				
Attribute(s)	<p>The following attributes must be recorded for this element:</p> <table border="1"> <thead> <tr> <th>Name</th> <th>Description</th> </tr> </thead> <tbody> <tr> <td>SeqNum</td> <td>The value recorded for this attribute must be numeric and unique. It may contain any numeric value up to 19 characters in length.</td> </tr> </tbody> </table>					Name	Description	SeqNum	The value recorded for this attribute must be numeric and unique. It may contain any numeric value up to 19 characters in length.
Name	Description								
SeqNum	The value recorded for this attribute must be numeric and unique. It may contain any numeric value up to 19 characters in length.								
Parent Element:	Party								
Element Restriction(s):	<p>Required. This element must be recorded for all party types (Activity Level) with the following exception:</p> <ul style="list-style-type: none"> In the event that all critical subject information is unavailable, do not record this element for the Subject (33) unless recording the subject's alternative name (if known). <p>The following table describes the minimum and maximum reporting requirements per party type (at the activity level):</p>								

Element Name:	PartyName	minOccurs:	0	maxOccurs:	100
	Party type	Legal (min-max)	Alternate (min-max)		
	Transmitter	1-1	n/a		
	Transmitter Contact	1-1	n/a		
	Filing Institution	1-1	0-1		
	Filing Institution Contact Office	1-1	n/a		
	Law Enforcement Agency	0-1	n/a		
	Law Enforcement Name	0-1	n/a		
	Financial Institution Where Activity Occurred	1-1	0-99		
	Subject*	0-1	0-99		
	*In the event that all critical subject information is unavailable, do not record the <PartyName> element for the Subject (33) unless recording the subjects alternative name (if known).				
Value Restriction(s):	n/a				
Remarks:	<p>The batch submission will be rejected if any of the following conditions are true:</p> <ul style="list-style-type: none"> The element is recorded for a party type that is not applicable to this data (see Element Restrictions for more information). The element is missing a "SeqNum" attribute. The element contains a "SeqNum" attribute with a duplicate or invalid value. <p>The batch submission will be accepted with warning if any of the following conditions are true:</p> <ul style="list-style-type: none"> The element is not recorded for the Subject (33) legal name and <AllCriticalSubjectInformationUnavailableIndicator> does not contain a "Y" value. More than one legal name is recorded for a party within a single FinCEN SAR Activity. 				
Example:	<pre><fc2:PartyName SeqNum="62"> <fc2:FirstNameUnknownIndicator>Y</fc2:FirstNameUnknownIndicator> <fc2:PartyNameTypeCode>L</fc2:PartyNameTypeCode> <fc2:RawEntityIndividualLastName>Mann</fc2:RawEntityIndividualLastName> <fc2:RawIndividualMiddleName>Randy</fc2:RawIndividualMiddleName> <fc2:RawIndividualNameSuffixText>Junior</fc2:RawIndividualNameSuffixText> </fc2:PartyName></pre>				

Element Name:	EntityLastNameUnknownIndicator	minOccurs:	0	maxOccurs:	1
Description:	<p>Entity name or Individual last name unknown (indicator). This element declares that the person legal name (if entity) or last name (if individual) is unknown. This element corresponds with the following item(s):</p> <ul style="list-style-type: none"> Subject: 4a. Individual's last name or entity's legal name (unknown) Financial Institution Where Activity Occurred: 57a. Legal name of Financial Institution (unknown) <p>Please refer to Attachment C for additional information regarding the above item(s).</p>				
Attribute(s)	n/a				
Parent Element:	PartyName				
Element Restriction(s):	<p>Conditionally Required. Record this element for the following party types and conditions; otherwise, do not record this element:</p> <ul style="list-style-type: none"> Subject (33), the <PartyNameTypeCode> is "L" (legal), and the legal entity/last name of the subject is unknown. Financial institution where activity occurred (34), the <PartyNameTypeCode> is "L" (legal), and the institution legal name (entity or individual) is unknown. 				
Value Restriction(s):	The value provided must adhere to the following requirements: "Y" (to indicate entity/last name unknown)				

Element Name:	EntityLastNameUnknownIndicator	minOccurs:	0	maxOccurs:	1
Remarks:	The batch submission will be rejected if any of the following conditions are true: <ul style="list-style-type: none"> The element is recorded for a party type that is not applicable to this data (see Element Restrictions for more information). The value recorded is not equal to "Y" or not equal to null. 				
Example:	<fc2:EntityLastNameUnknownIndicator>Y</fc2:EntityLastNameUnknownIndicator>				

Element Name:	FirstNameUnknownIndicator	minOccurs:	0	maxOccurs:	1
Description:	Individual first name unknown (indicator). This element declares that the first name of the subject is unknown. This element corresponds with the following item(s): <ul style="list-style-type: none"> 5a. First name (unknown) <i>Please refer to Attachment C for additional information regarding the above item(s).</i>				
Attribute(s)	n/a				
Parent Element:	PartyName				
Element Restriction(s):	Conditionally Required. Record this element for the Subject (33) party type when the <PartyNameTypeCode> is "L" (legal) and the first name of the subject is unknown; otherwise, do not record this element.				
Value Restriction(s):	The value provided must adhere to the following requirements: "Y" (to indicate first name unknown)				
Remarks:	The batch submission will be rejected if any of the following conditions are true: <ul style="list-style-type: none"> The element is recorded for a party type that is not applicable to this data (see Element Restrictions for more information). The value recorded is not equal to "Y" or not equal to null. 				
Example:	<fc2:FirstNameUnknownIndicator>Y</fc2:FirstNameUnknownIndicator>				

Element Name:	PartyNameTypeCode	minOccurs:	1	maxOccurs:	1
Description:	Party name type (code). This element identifies the type of name recorded for the party; specifically, legal name, doing business as (DBA) name, or also known as (AKA) name. This element corresponds with the following item(s): <ul style="list-style-type: none"> Transmitter <ul style="list-style-type: none"> Name (legal) Transmitter Contact <ul style="list-style-type: none"> Name (legal) Filing Institution <ul style="list-style-type: none"> 76. Filer name (legal) 87. Alternate name (dba/aka) 89. LE contact agency (legal) 90. LE contact name (legal) 93. Designated contact office (legal) Financial Institution Where Activity Occurred <ul style="list-style-type: none"> 57. Legal name of financial institution (legal) 58. Alternate name (dba/aka) Subject: <ul style="list-style-type: none"> 4. Individual's last name or entity's legal name (legal) 9. Alternate name (dba/aka) <i>Please refer to Attachment C for additional information regarding the above item(s).</i>				
Attribute(s)	n/a				
Parent Element:	PartyName				
Element Restriction(s):	Required. This element must be recorded.				
Value Restriction(s):	The value provided must adhere to the following requirements: Identify the party name type by recording the appropriate code from the list below:				

Element Name:	PartyNameTypeCode	minOccurs:	1	maxOccurs:	1								
	<table border="1"> <thead> <tr> <th>Code</th> <th>Description</th> </tr> </thead> <tbody> <tr> <td>L</td> <td>Legal</td> </tr> <tr> <td>DBA</td> <td>Doing Business As*</td> </tr> <tr> <td>AKA</td> <td>Also Known As*</td> </tr> </tbody> </table>	Code	Description	L	Legal	DBA	Doing Business As*	AKA	Also Known As*				
Code	Description												
L	Legal												
DBA	Doing Business As*												
AKA	Also Known As*												
	<p>*DBA and AKA name types may only be used for the following party types:</p> <ul style="list-style-type: none"> Filing Institution (30) Financial Institution Where Activity Occurred (34) Subject (33) 												
Remarks:	<p>The batch submission will be <u>rejected</u> if any of the following conditions are true:</p> <ul style="list-style-type: none"> The element is not recorded. The element is recorded but with no value (i.e. the value is null). The element contains an invalid value. The element is recorded with a value that is not approved for the associated party type (see Value Restrictions for more information). 												
Example:	<fc2:PartyNameTypeCode>L</fc2:PartyNameTypeCode>												

Element Name:	RawEntityIndividualLastName	minOccurs:	0	maxOccurs:	1
Description:	<p>Entity name or Individual last name (text). This element identifies the subject's legal name, whether it be the legal name of the entity or the last name of the individual. This element corresponds with the following item(s):</p> <ul style="list-style-type: none"> 4. Individual's last name or entity's legal name <p><i>Please refer to Attachment C for additional information regarding the above item(s).</i></p>				
Attribute(s)	n/a				
Parent Element:	PartyName				
Element Restriction(s):	<p>Conditionally Required. Record this element when the party type is associated with the Subject (33), the <PartyNameTypeCode> is "L" (legal), and the entity/last name of the subject is known*; otherwise, do not record this element.</p> <p>*If the entity/last name of the subject is unknown, record the <EntityLastNameUnknownIndicator> element with the value "Y" and do not record the <RawEntityIndividualLastName> element.</p>				
Value Restriction(s):	The value provided must adhere to the following requirements: 150 characters or less				
Remarks:	<p>The batch submission will be <u>rejected</u> if any of the following conditions are true:</p> <ul style="list-style-type: none"> The element is recorded for a party type that is not applicable to this data (see Element Restrictions for more information). <p>The batch submission will be <u>accepted with warning</u> if any of the following conditions are true:</p> <ul style="list-style-type: none"> The element is not recorded or does not contain a value for the Subject and unknown is not indicated. 				
Example:	<fc2:RawEntityIndividualLastName>Mann</fc2:RawEntityIndividualLastName>				

Element Name:	RawIndividualFirstName	minOccurs:	0	maxOccurs:	1
Description:	<p>Individual first name (text). This element identifies the first name of the subject. This element corresponds with the following item(s):</p> <ul style="list-style-type: none"> 5. First name <p><i>Please refer to Attachment C for additional information regarding the above item(s).</i></p>				
Attribute(s)	n/a				
Parent Element:	PartyName				

Element Name:	RawIndividualFirstName	minOccurs:	0	maxOccurs:	1
Element Restriction(s):	Conditionally Required. Record this element when the party type is associated with the Subject (33), the <PartyNameTypeCode> is "L" (legal), the subject is an individual, and the first name is known*; otherwise, do not record this element. *If the subject is an individual and the first name is unknown, record the <FirstNameUnknownIndicator> with the value "Y" and do not record the following elements: <ul style="list-style-type: none"> • <RawIndividualFirstName> • <PartyAsEntityOrganizationIndicator> 				
Value Restriction(s):	The value provided must adhere to the following requirements: 35 characters or less				
Remarks:	The batch submission will be <u>rejected</u> if any of the following conditions are true: <ul style="list-style-type: none"> • The element is recorded for a party type that is not applicable to this data (see Element Restrictions for more information). The batch submission will be <u>accepted with warning</u> if any of the following conditions are true: <ul style="list-style-type: none"> • The element is not recorded or does not contain a value for an individual Subject and unknown is not indicated. 				
Example:	<fc2:RawIndividualFirstName>Will</fc2:RawIndividualFirstName>				

Element Name:	RawIndividualMiddleName	minOccurs:	0	maxOccurs:	1
Description:	Individual middle name (text). This element identifies the middle name of the subject. This element corresponds with the following item(s): <ul style="list-style-type: none"> • 6. Middle name <i>Please refer to Attachment C for additional information regarding the above item(s).</i>				
Attribute(s)	n/a				
Parent Element:	PartyName				
Element Restriction(s):	Record this element when the party type is associated with the Subject (33), the <PartyNameTypeCode> is "L" (legal), the subject is an individual, and the middle name is known*; otherwise, do not record this element. *If the subject is an individual and the middle name is unknown, this element (along with the <PartyAsEntityOrganizationIndicator> element) should not be recorded.				
Value Restriction(s):	The value provided must adhere to the following requirements: 35 characters or less				
Remarks:	The batch submission will be <u>rejected</u> if any of the following conditions are true: <ul style="list-style-type: none"> • The element is recorded for a party type that is not applicable to this data (see Element Restrictions for more information). 				
Example:	<fc2:RawIndividualMiddleName>Randy</fc2:RawIndividualMiddleName>				

Element Name:	RawIndividualNameSuffixText	minOccurs:	0	maxOccurs:	1
Description:	Individual suffix name (text). This element identifies the suffix name of the subject. This element corresponds with the following item(s): <ul style="list-style-type: none"> • 7. Suffix <i>Please refer to Attachment C for additional information regarding the above item(s).</i>				
Attribute(s)	n/a				
Parent Element:	PartyName				
Element Restriction(s):	Record this element when the party type is associated with the Subject (33), the <PartyNameTypeCode> is "L" (legal), the subject is an individual, and the suffix name is known*; otherwise, do not record this element. *If the subject is an individual and the suffix name is unknown, this element (along with the <PartyAsEntityOrganizationIndicator> element) should not be recorded.				
Value Restriction(s):	The value provided must adhere to the following requirements: 35 characters or less				

Element Name:	RawIndividualNameSuffixText	minOccurs:	0	maxOccurs:	1
Remarks:	The batch submission will be <u>rejected</u> if any of the following conditions are true: <ul style="list-style-type: none"> The element is recorded for a party type that is not applicable to this data (see Element Restrictions for more information). 				
Example:	<fc2:RawIndividualNameSuffixText>Junior</fc2:RawIndividualNameSuffixText>				

Element Name:	RawPartyFullName	minOccurs:	0	maxOccurs:	1
Description:	<p>Party full name (text). This element identifies the full name of the party, whether it be the legal name if the institution, or DBA/AKA name of the institution or individual. This element corresponds with the following item(s):</p> <ul style="list-style-type: none"> Transmitter <ul style="list-style-type: none"> Name (legal) Transmitter Contact <ul style="list-style-type: none"> Name (legal) Filing Institution <ul style="list-style-type: none"> 76. Filer name (legal) 87. Alternate name (dba/aka) 89. LE contact agency (legal) 90. LE contact name (legal) 93. Designated contact office (legal) Financial Institution Where Activity Occurred <ul style="list-style-type: none"> 57. Legal name of financial institution (legal) 58. Alternate name (dba/aka) Subject: <ul style="list-style-type: none"> 9. Alternate name (dba/aka) <p><i>Please refer to Attachment C for additional information regarding the above item(s).</i></p>				
Attribute(s)	n/a				
Parent Element:	PartyName				
Element Restriction(s):	<p>Conditionally Required. Record this element for the following party types and conditions:</p> <ul style="list-style-type: none"> The PartyNameTypeCode is "L" (legal) and the party type is associated with: <ul style="list-style-type: none"> Transmitter (35) Transmitter Contact (37) (NOTE: The value recorded must be the name of the individual to be contacted on issues involving the batch file. This entry must be the same for all FinCEN SARs in the batch file.) Filing Institution (30) Designated Contact Office (8) (NOTE: This value recorded must be the title of the administrative office (such as Compliance Office) that should be contacted for additional information about the FinCEN SAR.) LE Contact Agency (18) LE Contact Name (19) Financial Institution Where Activity Occurred (34) and the legal name is known. If the Financial Institution (34) legal name is unknown, record the <EntityLastNameUnknownIndicator> element with the value "Y" and do not record the <RawPartyFullName> element. The PartyNameTypeCode is "DBA" or "AKA" and the party type is associated with: <ul style="list-style-type: none"> Filing institution* (30) Financial Institution Where Activity Occurred* (34) Subject* (33) <p>*If there is no DBA or AKA name for the above party types, only record the <PartyName> element associated with the legal name.</p>				
Value Restriction(s):	The value provided must adhere to the following requirements: 150 characters or less				
Remarks:	The batch submission will be <u>rejected</u> if any of the following conditions are true: <ul style="list-style-type: none"> The element is recorded for a party type that is not applicable to this data (see Element Restrictions for more information). 				

Element Name:	RawPartyFullName	minOccurs:	0	maxOccurs:	1
	<ul style="list-style-type: none"> The element is not recorded for the financial institution where activity occurred legal name and unknown is not indicated. The element is not recorded with a value for the designated contact office. <p>The batch submission will be <u>accepted with warning</u> if any of the following conditions are true:</p> <ul style="list-style-type: none"> The element is recorded with a value for the financial institution where activity occurred legal name and unknown is indicated. The element is not recorded for the filing institution. 				
Example:	<pre><fc2:PartyName SeqNum="46"> <fc2:PartyNameTypeCode>L</fc2:PartyNameTypeCode> <fc2:RawPartyFullName>Union Bank of California</fc2:RawPartyFullName> </fc2:PartyName></pre>				

4.6.2. Address Elements

Element Name:	Address	minOccurs:	0	maxOccurs:	99																																																																
Description:	<p>Address (header). This is the container for information about the address of the party.</p> <p>The following sub-element is associated with this element:</p> <div style="background-color: #e1f5fe; padding: 10px; text-align: center;"> <p>Activity party type code definitions 35 = Transmitter 30 = Filing Institution 34 = Financial Institution Where Activity Occurred 33 = Subject</p> </div> <ol style="list-style-type: none"> Transmitter Information: Address (Required) <table border="1" style="width: 100%; border-collapse: collapse;"> <thead> <tr> <th>Name</th> <th>minOccurs</th> <th>maxOccurs</th> <th>Content</th> </tr> </thead> <tbody> <tr> <td>RawCityText</td> <td>1</td> <td>1</td> <td>Simple</td> </tr> <tr> <td>RawCountryCodeText</td> <td>1</td> <td>1</td> <td>Simple</td> </tr> <tr> <td>RawStateCodeText</td> <td>1</td> <td>1</td> <td>Simple</td> </tr> <tr> <td>RawStreetAddress1Text</td> <td>1</td> <td>1</td> <td>Simple</td> </tr> <tr> <td>RawZIPCode</td> <td>1</td> <td>1</td> <td>Simple</td> </tr> </tbody> </table> Filing Institution Information: Address (Required FinCEN SAR Part IV, Items 82-86) <table border="1" style="width: 100%; border-collapse: collapse;"> <thead> <tr> <th>Name</th> <th>minOccurs</th> <th>maxOccurs</th> <th>Content</th> </tr> </thead> <tbody> <tr> <td>RawCityText (Item 83)</td> <td>1</td> <td>1</td> <td>Simple</td> </tr> <tr> <td>RawCountryCodeText (Item 86)</td> <td>1</td> <td>1</td> <td>Simple</td> </tr> <tr> <td>RawStateCodeText (Item 84)</td> <td>1</td> <td>1</td> <td>Simple</td> </tr> <tr> <td>RawStreetAddress1Text (Item 82)</td> <td>1</td> <td>1</td> <td>Simple</td> </tr> <tr> <td>RawZIPCode (Item 85)</td> <td>1</td> <td>1</td> <td>Simple</td> </tr> </tbody> </table> Financial Institution Where Activity Occurred: Address/Unknown (Required FinCEN SAR Part III, Items 61-65) <table border="1" style="width: 100%; border-collapse: collapse;"> <thead> <tr> <th>Name</th> <th>minOccurs</th> <th>maxOccurs</th> <th>Content</th> </tr> </thead> <tbody> <tr> <td>CityUnknownIndicator (Item 62a)</td> <td>0</td> <td>1</td> <td>Simple</td> </tr> <tr> <td>CountryCodeUnknownIndicator (Item 65a)</td> <td>0</td> <td>1</td> <td>Simple</td> </tr> <tr> <td>RawCityText (Item 62)</td> <td>0</td> <td>1</td> <td>Simple</td> </tr> </tbody> </table> 					Name	minOccurs	maxOccurs	Content	RawCityText	1	1	Simple	RawCountryCodeText	1	1	Simple	RawStateCodeText	1	1	Simple	RawStreetAddress1Text	1	1	Simple	RawZIPCode	1	1	Simple	Name	minOccurs	maxOccurs	Content	RawCityText (Item 83)	1	1	Simple	RawCountryCodeText (Item 86)	1	1	Simple	RawStateCodeText (Item 84)	1	1	Simple	RawStreetAddress1Text (Item 82)	1	1	Simple	RawZIPCode (Item 85)	1	1	Simple	Name	minOccurs	maxOccurs	Content	CityUnknownIndicator (Item 62a)	0	1	Simple	CountryCodeUnknownIndicator (Item 65a)	0	1	Simple	RawCityText (Item 62)	0	1	Simple
Name	minOccurs	maxOccurs	Content																																																																		
RawCityText	1	1	Simple																																																																		
RawCountryCodeText	1	1	Simple																																																																		
RawStateCodeText	1	1	Simple																																																																		
RawStreetAddress1Text	1	1	Simple																																																																		
RawZIPCode	1	1	Simple																																																																		
Name	minOccurs	maxOccurs	Content																																																																		
RawCityText (Item 83)	1	1	Simple																																																																		
RawCountryCodeText (Item 86)	1	1	Simple																																																																		
RawStateCodeText (Item 84)	1	1	Simple																																																																		
RawStreetAddress1Text (Item 82)	1	1	Simple																																																																		
RawZIPCode (Item 85)	1	1	Simple																																																																		
Name	minOccurs	maxOccurs	Content																																																																		
CityUnknownIndicator (Item 62a)	0	1	Simple																																																																		
CountryCodeUnknownIndicator (Item 65a)	0	1	Simple																																																																		
RawCityText (Item 62)	0	1	Simple																																																																		

Element Name:	Address	minOccurs:	0	maxOccurs:	99																																												
	RawCountryCodeText (Item 65)		0	1	Simple																																												
	RawStateCodeText (Item 63)		0	1	Simple																																												
	RawStreetAddress1Text (Item 61)		0	1	Simple																																												
	RawZIPCode (Item 64)		0	1	Simple																																												
	StreetAddressUnknownIndicator (Item 61a)		0	1	Simple																																												
	ZIPCodeUnknownIndicator (Item 64a)		0	1	Simple																																												
	<p><i>*If unknown is indicated, the corresponding element whose value is unknown should not be recorded; otherwise, the unknown indicator element should not be recorded.</i></p> <p>4. Subject: Address/Unknown* (Conditionally Required FinCEN SAR Part I, Items 11-15)</p> <table border="1"> <thead> <tr> <th>Name</th> <th>minOccurs</th> <th>maxOccurs</th> <th>Content</th> </tr> </thead> <tbody> <tr> <td>CityUnknownIndicator (Item 12a)</td> <td>0</td> <td>1</td> <td>Simple</td> </tr> <tr> <td>CountryCodeUnknownIndicator (Item 15a)</td> <td>0</td> <td>1</td> <td>Simple</td> </tr> <tr> <td>RawCityText (Item 12)</td> <td>0</td> <td>1</td> <td>Simple</td> </tr> <tr> <td>RawCountryCodeText (Item 15)</td> <td>0</td> <td>1</td> <td>Simple</td> </tr> <tr> <td>RawStateCodeText (Item 13)</td> <td>0</td> <td>1</td> <td>Simple</td> </tr> <tr> <td>RawStreetAddress1Text (Item 11)</td> <td>0</td> <td>1</td> <td>Simple</td> </tr> <tr> <td>RawZIPCode (Item 14)</td> <td>0</td> <td>1</td> <td>Simple</td> </tr> <tr> <td>StateCodeUnknownIndicator (Item 13a)</td> <td>0</td> <td>1</td> <td>Simple</td> </tr> <tr> <td>StreetAddressUnknownIndicator (Item 11a)</td> <td>0</td> <td>1</td> <td>Simple</td> </tr> <tr> <td>ZIPCodeUnknownIndicator (Item 14a)</td> <td>0</td> <td>1</td> <td>Simple</td> </tr> </tbody> </table> <p><i>*If unknown is indicated, the corresponding element whose value is unknown should not be recorded; otherwise, the unknown indicator element should not be recorded. In the event that all critical subject information is unavailable, do not record the <Address> element for the Subject (33).</i></p>					Name	minOccurs	maxOccurs	Content	CityUnknownIndicator (Item 12a)	0	1	Simple	CountryCodeUnknownIndicator (Item 15a)	0	1	Simple	RawCityText (Item 12)	0	1	Simple	RawCountryCodeText (Item 15)	0	1	Simple	RawStateCodeText (Item 13)	0	1	Simple	RawStreetAddress1Text (Item 11)	0	1	Simple	RawZIPCode (Item 14)	0	1	Simple	StateCodeUnknownIndicator (Item 13a)	0	1	Simple	StreetAddressUnknownIndicator (Item 11a)	0	1	Simple	ZIPCodeUnknownIndicator (Item 14a)	0	1	Simple
Name	minOccurs	maxOccurs	Content																																														
CityUnknownIndicator (Item 12a)	0	1	Simple																																														
CountryCodeUnknownIndicator (Item 15a)	0	1	Simple																																														
RawCityText (Item 12)	0	1	Simple																																														
RawCountryCodeText (Item 15)	0	1	Simple																																														
RawStateCodeText (Item 13)	0	1	Simple																																														
RawStreetAddress1Text (Item 11)	0	1	Simple																																														
RawZIPCode (Item 14)	0	1	Simple																																														
StateCodeUnknownIndicator (Item 13a)	0	1	Simple																																														
StreetAddressUnknownIndicator (Item 11a)	0	1	Simple																																														
ZIPCodeUnknownIndicator (Item 14a)	0	1	Simple																																														
Attribute(s)	<p>The following attributes must be recorded for this element:</p> <table border="1"> <thead> <tr> <th>Name</th> <th>Description</th> </tr> </thead> <tbody> <tr> <td>SeqNum</td> <td>The value recorded for this attribute must be numeric and unique. It may contain any numeric value up to 19 characters in length.</td> </tr> </tbody> </table>					Name	Description	SeqNum	The value recorded for this attribute must be numeric and unique. It may contain any numeric value up to 19 characters in length.																																								
Name	Description																																																
SeqNum	The value recorded for this attribute must be numeric and unique. It may contain any numeric value up to 19 characters in length.																																																
Parent Element:	Party																																																
Element Restriction(s):	<p>Required. This element must be recorded for the following party types (activity level):</p> <table border="1"> <thead> <tr> <th>Party type</th> <th>Address (min-max)</th> </tr> </thead> <tbody> <tr> <td>Transmitter</td> <td>1-1</td> </tr> <tr> <td>Filing Institution</td> <td>1-1</td> </tr> <tr> <td>Financial Institution Where Activity Occurred</td> <td>1-1</td> </tr> <tr> <td>Subject*</td> <td>0-99</td> </tr> </tbody> </table> <p><i>*In the event that all critical subject information is unavailable, do not record the <Address> element for the Subject (33).</i></p>					Party type	Address (min-max)	Transmitter	1-1	Filing Institution	1-1	Financial Institution Where Activity Occurred	1-1	Subject*	0-99																																		
Party type	Address (min-max)																																																
Transmitter	1-1																																																
Filing Institution	1-1																																																
Financial Institution Where Activity Occurred	1-1																																																
Subject*	0-99																																																
Value Restriction(s):	n/a																																																
Remarks:	<p>The batch submission will be <u>rejected</u> if any of the following conditions are true:</p> <ul style="list-style-type: none"> The element is recorded for a party type that is not applicable to this data (see Element Restrictions for more information). The element is missing a "SeqNum" attribute. The element contains a "SeqNum" attribute with a duplicate or invalid value. 																																																

Element Name:	Address	minOccurs:	0	maxOccurs:	99
	The batch submission will be <u>accepted with warning</u> if any of the following conditions are true: <ul style="list-style-type: none"> The element is not recorded for the subject address and <AllCriticalSubjectInformationUnavailableIndicator> does not contain a "Y" value. The element is recorded for the subject address and <AllCriticalSubjectInformationUnavailableIndicator> contains a "Y" value. 				
Example:	<pre><fc2:Address SeqNum="48"> <fc2:CityUnknownIndicator>Y</fc2:CityUnknownIndicator> <fc2:RawCountryCodeText>US</fc2:RawCountryCodeText> <fc2:RawStateCodeText>VA</fc2:RawStateCodeText> <fc2:RawStreetAddress1Text>987 Rocky Road</fc2:RawStreetAddress1Text> <fc2:RawZIPCode>87598</fc2:RawZIPCode> </fc2:Address></pre>				

Element Name:	CityUnknownIndicator	minOccurs:	0	maxOccurs:	1
Description:	City unknown (indicator). This element declares that the city associated with the address of the party is unknown. This element corresponds with the following item(s): <ul style="list-style-type: none"> 12a. City (unknown): Subject 62a. City (unknown): Financial Institution Where Activity Occurred <i>Please refer to Attachment C for additional information regarding the above item(s).</i>				
Attribute(s)	n/a				
Parent Element:	Address				
Element Restriction(s):	Conditionally Required. Record this element when the city is unknown* for the following party types: <ul style="list-style-type: none"> Financial institution where activity occurred (34) Subject (33) *If the city is known, record the <RawCityText> element with city name and do not record the <CityUnknownIndicator> element.				
Value Restriction(s):	The value provided must adhere to the following requirements: "Y" (to indicate city unknown)				
Remarks:	The batch submission will be <u>rejected</u> if any of the following conditions are true: <ul style="list-style-type: none"> The element is recorded for a party type that is not applicable to this data (see Element Restrictions for more information). The value recorded is not equal to "Y" or not equal to null. 				
Example:	<fc2:CityUnknownIndicator>Y</fc2:CityUnknownIndicator>				

Element Name:	CountryCodeUnknownIndicator	minOccurs:	0	maxOccurs:	1
Description:	Country unknown (indicator). This element declares that country associated with the address of the party is unknown. This element corresponds with the following item(s): <ul style="list-style-type: none"> 15a. Country Code (unknown): Subject 65a. Country Code (unknown): Financial Institution Where Activity Occurred <i>Please refer to Attachment C for additional information regarding the above item(s).</i>				
Attribute(s)	n/a				
Parent Element:	Address				
Element Restriction(s):	Conditionally Required. Record this element when the country is unknown* for the following party types: <ul style="list-style-type: none"> Financial institution where activity occurred (34) Subject (33) *If the country is known, record the <RawCountryCodeText> element with the ISO 3166-2 country code and do not record the <CountryCodeUnknownIndicator> element.				
Value Restriction(s):	The value provided must adhere to the following requirements: "Y" (to indicate country unknown)				

Element Name:	CountryCodeUnknownIndicator	minOccurs:	0	maxOccurs:	1
Remarks:	The batch submission will be <u>rejected</u> if any of the following conditions are true: <ul style="list-style-type: none"> The element is recorded for a party type that is not applicable to this data (see Element Restrictions for more information). The value recorded is not equal to "Y" or not equal to null. 				
Example:	<fc2:CountryCodeUnknownIndicator>Y</fc2:CountryCodeUnknownIndicator>				

Element Name:	RawCityText	minOccurs:	0	maxOccurs:	1
Description:	City (text). This element identifies the city associated with the address of the party. This element corresponds with the following item(s): <ul style="list-style-type: none"> Transmitter: City Subject: 12. City Financial Institution Where Activity Occurred: 62. City Filing Institution: 83. City <i>Please refer to Attachment C for additional information regarding the above item(s).</i>				
Attribute(s)	n/a				
Parent Element:	Address				
Element Restriction(s):	Required. This element must be recorded for the following party types: <ul style="list-style-type: none"> Transmitter (35) Filing institution (30) Conditionally Required. Record this element when the city is known* for the following party types: <ul style="list-style-type: none"> Subject (33) Financial institution where activity occurred (34) *If the city is unknown, record the <CityUnknownIndicator> element with the value "Y" and do not record the <RawCityText> element.				
Value Restriction(s):	The value provided must adhere to the following requirements: 50 characters or less.				
Remarks:	The batch submission will be <u>rejected</u> if any of the following conditions are true: <ul style="list-style-type: none"> The element is recorded for a party type that is not applicable to this data (see Element Restrictions for more information). The batch submission will be <u>accepted with warning</u> if any of the following conditions are true: <ul style="list-style-type: none"> The element is not recorded or does not contain a value for the subject or the financial institution where activity occurred and unknown is not indicated. The element is not recorded or does not contain a value for the transmitter or filing institution. 				
Example:	<fc2:RawCityText>Tysons Corner</fc2:RawCityText>				

Element Name:	RawCountryCodeText	minOccurs:	0	maxOccurs:	1
Description:	Country (code). This element identifies the country associated with the party. This element corresponds with the following item(s): <ul style="list-style-type: none"> Transmitter: Country Code Subject: 15. Country Code Financial Institution Where Activity Occurred: 65. Country Code Filing Institution: 86. Country Code <i>Please refer to Attachment C for additional information regarding the above item(s).</i>				
Attribute(s)	n/a				
Parent Element:	Address				
Element Restriction(s):	Required. This element must be recorded for the following party types: <ul style="list-style-type: none"> Transmitter (35) Filing institution (30) 				

Element Name:	RawCountryCodeText	minOccurs:	0	maxOccurs:	1
	Conditionally Required. Record this element when the country is known* for the following party types: <ul style="list-style-type: none"> • Subject (33) • Financial institution where activity occurred (34) *If the country is unknown, record the <CountryCodeUnknownIndicator> element with the value "Y" and do not record the <RawCountryCodeText> element.				
Value Restriction(s):	The value provided must adhere to the following requirements: Country codes (including U.S. Territory codes) must adhere to the two-letter country codes found in ISO 3166-2.				
Remarks:	The batch submission will be <u>rejected</u> if any of the following conditions are true: <ul style="list-style-type: none"> • The element is recorded for a party type that is not applicable to this data (see Element Restrictions for more information). • The value recorded is not a valid country code. The batch submission will be <u>accepted with warning</u> if any of the following conditions are true: <ul style="list-style-type: none"> • The element is not recorded or does not contain a value for the transmitter or filing institution. • The element is not recorded or does not contains a value for the subject or the financial institution where activity occurred and unknown is not indicated. • State code and country code mismatch when U.S. Territory is recorded. 				
Example:	<fc2:RawCountryCodeText>US</fc2:RawCountryCodeText>				

Element Name:	RawStateCodeText	minOccurs:	0	maxOccurs:	1
Description:	State/Territory/Province (code). This element identifies the state/territory/province associated with the address of the party when the corresponding country is equal to US (United States), CA (Canada), MX (Mexico), or a U.S. Territory. This element corresponds with the following item(s): <ul style="list-style-type: none"> • Transmitter: State • Subject: 13. State • Financial Institution Where Activity Occurred: 63. State • Filing Institution: 84. State <i>Please refer to Attachment C for additional information regarding the above item(s).</i>				
Attribute(s)	n/a				
Parent Element:	Address				
Element Restriction(s):	Conditionally Required. Record this element for the following party types when the corresponding country is US (United States), CA (Canada), MX (Mexico), or a U.S. Territory*; otherwise, do not record this element: <ul style="list-style-type: none"> • Transmitter (35) • Filing institution (30) • Subject (33) and the state is known** • Financial institution where activity occurred (34) *If the country is a U.S. Territory, record the same U.S. Territory code for the state. **If the subject's state is unknown, record the <StateCodeUnknownIndicator> element with the value "Y" and do not record the <RawStateCodeText> element.				
Value Restriction(s):	The value provided must adhere to the following requirements: United States state/territory codes must adhere to the two-letter codes used by the United States Postal Service when the country is equal to US or a U.S. Territory. If a U.S. Territory is recorded for the country, it must also be recorded for the state. Canadian province/territory codes must adhere to the two-letter codes used by the Canadian Post Corporation when the country is equal to CA. Mexican state/federal district codes must adhere to the standards of ISO 3166-2:MX when the country is equal to MX.				
Remarks:	The batch submission will be <u>rejected</u> if any of the following conditions are true: <ul style="list-style-type: none"> • The element is recorded for a party type that is not applicable to this data (see Element Restrictions for more information). • The value recorded is not a valid state code. The batch submission will be <u>accepted with warning</u> if any of the following conditions are true: <ul style="list-style-type: none"> • The element is not recorded or does not contain a value for the transmitter or filing institution when the country is US, CA, MX, or a U.S. Territory. 				

Element Name:	RawStateCodeText	minOccurs:	0	maxOccurs:	1
	<ul style="list-style-type: none"> The element is not recorded or does not contains a value for the subject or the financial institution where activity occurred when the country is US, CA, or MX, and unknown is not indicated. The element contains a value and the country is not US, CA, MX, or a U.S. Territory. State code and country code mismatch when U.S. Territory is recorded. 				
Example:	<fc2:RawStateCodeText>VA</fc2:RawStateCodeText>				

Element Name:	RawStreetAddress1Text	minOccurs:	0	maxOccurs:	1
Description:	<p>Street address (text). This element identifies the street address of the party. This element corresponds with the following item(s):</p> <ul style="list-style-type: none"> Transmitter: Street Address Subject: 11. Street Address Financial Institution Where Activity Occurred: 61. Street Address Filing Institution: 82. Street Address <p><i>Please refer to Attachment C for additional information regarding the above item(s).</i></p>				
Attribute(s)	n/a				
Parent Element:	Address				
Element Restriction(s):	<p>Required. This element must be recorded for the following party types:</p> <ul style="list-style-type: none"> Transmitter (35) Filing institution (30) <p>Conditionally Required. Record this element when the street address is known* for the following party types:</p> <ul style="list-style-type: none"> Subject (33) Financial institution where activity occurred (34) <p>*If the street address is unknown, record the <StreetAddressUnknownIndicator> element with the value "Y" and do not record the <RawStreetAddress1Text> element.</p>				
Value Restriction(s):	The value provided must adhere to the following requirements: 100 characters or less				
Remarks:	<p>The batch submission will be <u>rejected</u> if any of the following conditions are true:</p> <ul style="list-style-type: none"> The element is recorded for a party type that is not applicable to this data (see Element Restrictions for more information). <p>The batch submission will be <u>accepted with warning</u> if any of the following conditions are true:</p> <ul style="list-style-type: none"> The element is not recorded or does not contain a value for the subject or the financial institution where activity occurred and unknown is not indicated. The element is not recorded or does not contain a value for the transmitter or filing institution. 				
Example:	<fc2:RawStreetAddress1Text>987 Rocky Road</fc2:RawStreetAddress1Text>				

Element Name:	RawZIPCode	minOccurs:	0	maxOccurs:	1
Description:	<p>ZIP/Postal Code (text). This element identifies the ZIP Code or foreign postal code associated with the address of the party. This element corresponds with the following item(s):</p> <ul style="list-style-type: none"> Transmitter: ZIP/Postal Code Subject: 14. ZIP/Postal Code Financial Institution Where Activity Occurred: 64. ZIP/Postal Code Filing Institution: 85. ZIP/Postal Code <p><i>Please refer to Attachment C for additional information regarding the above item(s).</i></p>				
Attribute(s)	n/a				
Parent Element:	Address				
Element Restriction(s):	Required. This element must be recorded for the following party types:				

Element Name:	RawZIPCode	minOccurs:	0	maxOccurs:	1
	<ul style="list-style-type: none"> • Transmitter (35) • Filing institution (30) Conditionally Required. Record this element when the ZIP/Postal Code is known* for the following party types: <ul style="list-style-type: none"> • Subject (33) • Financial institution where activity occurred (34) *If the ZIP/Postal Code is unknown, record the <ZIPCodeUnknownIndicator> element with the value "Y" and do not record the <RawZIPCode> element.				
Value Restriction(s):	The value provided must adhere to the following requirements: For a U.S. address (including U.S. Territories): 5 or 9 numeric character entry; 9 numeric character entry cannot end with four zeros or four nines. For a non-U.S. address: 9 (or less) character entry. Do not include punctuation or formatting such as hyphens, periods, and spaces within the value entry				
Remarks:	The batch submission will be rejected if any of the following conditions are true: <ul style="list-style-type: none"> • The element is recorded for a party type that is not applicable to this data (see Element Restrictions for more information). • The value recorded contains punctuation or formatting. The batch submission will be accepted with warning if any of the following conditions are true: <ul style="list-style-type: none"> • The element is not recorded or does not contain a value for the subject or the financial institution where activity occurred and unknown is not indicated. • The element is not recorded or does not contain a value for the transmitter or filing institution. • The value recorded is not equal to 5 or 9 numeric characters, is a 9-digit value ending in four zeros or four nines, and the corresponding country is equal to US or a U.S. Territory code. 				
Example:	<fc2:RawZIPCode>87598</fc2:RawZIPCode>				

Element Name:	StateCodeUnknownIndicator	minOccurs:	0	maxOccurs:	1
Description:	State unknown (indicator). This element declares that state associated with the address of the party is unknown when the corresponding country is equal to US (United States), CA (Canada), or MX (Mexico). This element corresponds with the following item(s): <ul style="list-style-type: none"> • 13a. State (unknown) <i>Please refer to Attachment C for additional information regarding the above item(s).</i>				
Attribute(s)	n/a				
Parent Element:	Address				
Element Restriction(s):	Conditionally Required. Record this element for the Subject (33) party type when the state is unknown* and the corresponding country is US (United States), CA (Canada), or MX (Mexico); otherwise, do not record this element. *If the subject's state is known, record the <RawStateCodeText> element with ISO 3166-2 state code and do not record the <StateCodeUnknownIndicator> element.				
Value Restriction(s):	The value provided must adhere to the following requirements: "Y" (to indicate state unknown)				
Remarks:	The batch submission will be rejected if any of the following conditions are true: <ul style="list-style-type: none"> • The element is recorded for a party type that is not applicable to this data (see Element Restrictions for more information). • The value recorded is not equal to "Y" or not equal to null. 				
Example:	<fc2:StateCodeUnknownIndicator>Y</fc2:StateCodeUnknownIndicator>				

Element Name:	StreetAddressUnknownIndicator	minOccurs:	0	maxOccurs:	1
Description:	Street address unknown (indicator). This element declares that the street address of the party is unknown. This element corresponds with the following item(s): <ul style="list-style-type: none"> • Subject: 11a. Address (unknown) 				

Element Name:	StreetAddressUnknownIndicator	minOccurs:	0	maxOccurs:	1
	<ul style="list-style-type: none"> Financial Institution Where Activity Occurred: 61a. Address (unknown) <i>Please refer to Attachment C for additional information regarding the above item(s).</i>				
Attribute(s)	n/a				
Parent Element:	Address				
Element Restriction(s):	Conditionally Required. Record this element when the street address is unknown* for the following party types: <ul style="list-style-type: none"> Subject (33) Financial institution where activity occurred (34) *If the street address is known, record the <RawStreetAddress1Text> element with street address and do not record the <StreetAddressUnknownIndicator> element.				
Value Restriction(s):	The value provided must adhere to the following requirements: "Y" (to indicate street address unknown)				
Remarks:	The batch submission will be rejected if any of the following conditions are true: <ul style="list-style-type: none"> The element is recorded for a party type that is not applicable to this data (see Element Restrictions for more information). The value recorded is not equal to "Y" or not equal to null. 				
Example:	<fc2:StreetAddressUnknownIndicator>Y</fc2:StreetAddressUnknownIndicator>				

Element Name:	ZIPCodeUnknownIndicator	minOccurs:	0	maxOccurs:	1
Description:	ZIP/Postal Code unknown (indicator). This element declares that the ZIP Code or foreign postal code associated with the address of the party is unknown. This element corresponds with the following item(s): <ul style="list-style-type: none"> Subject: 14a. ZIP/Postal Code (unknown) Financial Institution Where Activity Occurred: 64a. ZIP/Postal Code (unknown) <i>Please refer to Attachment C for additional information regarding the above item(s).</i>				
Attribute(s)	n/a				
Parent Element:	Address				
Element Restriction(s):	Conditionally Required. Record this element when the ZIP/Postal Code is unknown* for the following party types: <ul style="list-style-type: none"> Subject (33) Financial institution where activity occurred (34) *If the ZIP/Postal Code is known, record the <RawZIPCode> element with the code and do not record the <ZIPCodeUnknownIndicator> element.				
Value Restriction(s):	The value provided must adhere to the following requirements: "Y" (to indicate ZIP/Postal code unknown)				
Remarks:	The batch submission will be rejected if any of the following conditions are true: <ul style="list-style-type: none"> The element is recorded for a party type that is not applicable to this data (see Element Restrictions for more information). The value recorded is not equal to "Y" or not equal to null. 				
Example:	<fc2:ZIPCodeUnknownIndicator>Y</fc2:ZIPCodeUnknownIndicator>				

4.6.3. PhoneNumber Elements

Element Name:	PhoneNumber	minOccurs:	0	maxOccurs:	99
Description:	Telephone number (header). This is the container for information about the telephone number of the party.				

Element Name:	PhoneNumber	minOccurs:	0	maxOccurs:	99																
	The following sub-element is associated with this element:																				
	Activity party type code definitions 35 = Transmitter 8 = Contact Office 19 = LE Contact Name 33 = Subject																				
	1. Transmitter Information: Telephone (Required)																				
	<table border="1"> <thead> <tr> <th>Name</th> <th>minOccurs</th> <th>maxOccurs</th> <th>Content</th> </tr> </thead> <tbody> <tr> <td>PhoneNumberText</td> <td>1</td> <td>1</td> <td>Simple</td> </tr> </tbody> </table>					Name	minOccurs	maxOccurs	Content	PhoneNumberText	1	1	Simple								
Name	minOccurs	maxOccurs	Content																		
PhoneNumberText	1	1	Simple																		
	2. Contact Office: Telephone (Required FinCEN SAR Part IV, Item 94)																				
	<table border="1"> <thead> <tr> <th>Name</th> <th>minOccurs</th> <th>maxOccurs</th> <th>Content</th> </tr> </thead> <tbody> <tr> <td>PhoneNumberExtensionText (Item 94a)</td> <td>0</td> <td>1</td> <td>Simple</td> </tr> <tr> <td>PhoneNumberText (Item 94)</td> <td>1</td> <td>1</td> <td>Simple</td> </tr> </tbody> </table>					Name	minOccurs	maxOccurs	Content	PhoneNumberExtensionText (Item 94a)	0	1	Simple	PhoneNumberText (Item 94)	1	1	Simple				
Name	minOccurs	maxOccurs	Content																		
PhoneNumberExtensionText (Item 94a)	0	1	Simple																		
PhoneNumberText (Item 94)	1	1	Simple																		
	3. LE Contact Name: Telephone (If applicable FinCEN SAR Part IV, Item 91)																				
	<table border="1"> <thead> <tr> <th>Name</th> <th>minOccurs</th> <th>maxOccurs</th> <th>Content</th> </tr> </thead> <tbody> <tr> <td>PhoneNumberExtensionText (Item 91a)</td> <td>0</td> <td>1</td> <td>Simple</td> </tr> <tr> <td>PhoneNumberText (Item 91)</td> <td>0</td> <td>1</td> <td>Simple</td> </tr> </tbody> </table>					Name	minOccurs	maxOccurs	Content	PhoneNumberExtensionText (Item 91a)	0	1	Simple	PhoneNumberText (Item 91)	0	1	Simple				
Name	minOccurs	maxOccurs	Content																		
PhoneNumberExtensionText (Item 91a)	0	1	Simple																		
PhoneNumberText (Item 91)	0	1	Simple																		
	4. Subject: Telephone (If available FinCEN SAR Part I, Item 21)																				
	<table border="1"> <thead> <tr> <th>Name</th> <th>minOccurs</th> <th>maxOccurs</th> <th>Content</th> </tr> </thead> <tbody> <tr> <td>PhoneNumberExtensionText (Item 21a)</td> <td>0</td> <td>1</td> <td>Simple</td> </tr> <tr> <td>PhoneNumberText (Item 21)</td> <td>0</td> <td>1</td> <td>Simple</td> </tr> <tr> <td>PhoneNumberTypeCode (Item 20)</td> <td>0</td> <td>1</td> <td>Simple</td> </tr> </tbody> </table>					Name	minOccurs	maxOccurs	Content	PhoneNumberExtensionText (Item 21a)	0	1	Simple	PhoneNumberText (Item 21)	0	1	Simple	PhoneNumberTypeCode (Item 20)	0	1	Simple
Name	minOccurs	maxOccurs	Content																		
PhoneNumberExtensionText (Item 21a)	0	1	Simple																		
PhoneNumberText (Item 21)	0	1	Simple																		
PhoneNumberTypeCode (Item 20)	0	1	Simple																		
Attribute(s)	The following attributes must be recorded for this element:																				
	<table border="1"> <thead> <tr> <th>Name</th> <th>Description</th> </tr> </thead> <tbody> <tr> <td>SeqNum</td> <td>The value recorded for this attribute must be numeric and unique. It may contain any numeric value up to 19 characters in length.</td> </tr> </tbody> </table>					Name	Description	SeqNum	The value recorded for this attribute must be numeric and unique. It may contain any numeric value up to 19 characters in length.												
Name	Description																				
SeqNum	The value recorded for this attribute must be numeric and unique. It may contain any numeric value up to 19 characters in length.																				
Parent Element:	Party																				
Element Restriction(s):	Required. This element must be recorded for the following party types (activity level):																				
	<table border="1"> <thead> <tr> <th>Party type</th> <th>Telephone (min-max)</th> </tr> </thead> <tbody> <tr> <td>Transmitter</td> <td>1-1</td> </tr> <tr> <td>Contact Office</td> <td>1-1</td> </tr> <tr> <td>LE Contact Name</td> <td>0-1</td> </tr> <tr> <td>Subject</td> <td>0-99</td> </tr> </tbody> </table>					Party type	Telephone (min-max)	Transmitter	1-1	Contact Office	1-1	LE Contact Name	0-1	Subject	0-99						
Party type	Telephone (min-max)																				
Transmitter	1-1																				
Contact Office	1-1																				
LE Contact Name	0-1																				
Subject	0-99																				
Value Restriction(s):	n/a																				
Remarks:	The batch submission will be <u>rejected</u> if any of the following conditions are true: <ul style="list-style-type: none"> The element is recorded for a party type that is not applicable to this data (see Element Restrictions for more information). The element is missing a "SeqNum" attribute. 																				

Element Name:	PhoneNumber	minOccurs:	0	maxOccurs:	99
	<ul style="list-style-type: none"> The element contains a "SeqNum" attribute with a duplicate or invalid value. 				
Example:	<pre><fc2:PhoneNumber SeqNum="67"> <fc2:PhoneNumberExtensionText>5584</fc2:PhoneNumberExtensionText> <fc2:PhoneNumberText>6194760276</fc2:PhoneNumberText> <fc2:PhoneNumberTypeCode>R</fc2:PhoneNumberTypeCode> </fc2:PhoneNumber></pre>				

Element Name:	PhoneNumberExtensionText	minOccurs:	0	maxOccurs:	1
Description:	<p>Telephone extension (text). This element identifies the telephone extension associated with the telephone number of the party (if known). This element corresponds with the following item(s):</p> <ul style="list-style-type: none"> Subject: 21a. Phone number extension (if any) LE Contact Name: 91a. LE contact phone number extension (if any) Contact Office: 94a. Designated contact office phone number extension (if any) <p><i>Please refer to Attachment C for additional information regarding the above item(s).</i></p>				
Attribute(s)	n/a				
Parent Element:	PhoneNumber				
Element Restriction(s):	<p>Record this element when the telephone number extension is known for the following party types; otherwise, do not record this element:</p> <ul style="list-style-type: none"> Subject (33) LE Contact Name (19) Contact Office (8) 				
Value Restriction(s):	The value provided must adhere to the following requirements: 6 numeric characters or less				
Remarks:	<p>The batch submission will be <u>rejected</u> if any of the following conditions are true:</p> <ul style="list-style-type: none"> The element is recorded for a party type that is not applicable to this data (see Element Restrictions for more information). 				
Example:	<fc2:PhoneNumberExtensionText> 5584</fc2:PhoneNumberExtensionText>				

Element Name:	PhoneNumberText	minOccurs:	0	maxOccurs:	1
Description:	<p>Telephone number (text). This element identifies the telephone number of the party. This element corresponds with the following item(s):</p> <ul style="list-style-type: none"> Transmitter: Phone number Subject: 21. Phone number LE Contact Name: 91. LE contact phone number Contact Office: 94. Designated contact office phone number <p><i>Please refer to Attachment C for additional information regarding the above item(s).</i></p>				
Attribute(s)	n/a				
Parent Element:	PhoneNumber				
Element Restriction(s):	<p>Record this element for the following party types and circumstances; otherwise, do not record this element:</p> <ul style="list-style-type: none"> Transmitter (35)Contact Office (8) Subject (33) and the telephone number is known LE Contact Name (19) and the telephone number is known 				
Value Restriction(s):	<p>The value provided must adhere to the following requirements by party type:</p> <ul style="list-style-type: none"> Transmitter (35) <ul style="list-style-type: none"> 10 numeric characters; not all same digit (such as all 0's or all 9's). NOTE: This number must be the same for all FinCEN SARs in the batch file. Contact Office (8) / Subject (3) / LE Contact Name (19) <ul style="list-style-type: none"> 16 numeric characters or less; not all same digit (such as all 0's or all 9's) 				

Element Name:	PhoneNumberText	minOccurs:	0	maxOccurs:	1
	Do not include punctuation or formatting such as hyphens, periods, and spaces within the value entry regardless of party type.				
Remarks:	<p>The batch submission will be rejected if any of the following conditions are true:</p> <ul style="list-style-type: none"> The element is recorded for a party type that is not applicable to this data (see Element Restrictions for more information). <p>The batch submission will be accepted with warning if any of the following conditions are true:</p> <ul style="list-style-type: none"> The element is not recorded or does not contain a value for the designated contact office. 				
Example:	<fc2:PhoneNumberText>6194760276</fc2:PhoneNumberText>				

Element Name:	PhoneNumberTypeCode	minOccurs:	0	maxOccurs:	1										
Description:	<p>Telephone number type (code). This element identifies the telephone number type associated with the subject. This element corresponds with the following item(s):</p> <ul style="list-style-type: none"> 20. Phone number – type <ul style="list-style-type: none"> a. Home b. Work c. Mobile d. Fax <p><i>Please refer to Attachment C for additional information regarding the above item(s).</i></p>														
Attribute(s)	n/a														
Parent Element:	PhoneNumber														
Element Restriction(s):	Record this element for the Subject (33) party type when a phone number is recorded with the <PhoneNumberText> element; otherwise, do not record this element.														
Value Restriction(s):	<p>The value provided must adhere to the following requirements: Identify the phone number type by recording the appropriate code from the list below:</p> <table border="1"> <thead> <tr> <th>Code</th> <th>Description</th> </tr> </thead> <tbody> <tr> <td>R</td> <td>Residence (Home)</td> </tr> <tr> <td>W</td> <td>Work</td> </tr> <tr> <td>M</td> <td>Mobile</td> </tr> <tr> <td>F</td> <td>Fax</td> </tr> </tbody> </table>					Code	Description	R	Residence (Home)	W	Work	M	Mobile	F	Fax
Code	Description														
R	Residence (Home)														
W	Work														
M	Mobile														
F	Fax														
Remarks:	<p>The batch submission will be rejected if any of the following conditions are true:</p> <ul style="list-style-type: none"> The element is recorded for a party type that is not applicable to this data (see Element Restrictions for more information). The value recorded is an invalid code. 														
Example:	<fc2:PhoneNumberTypeCode>R</fc2:PhoneNumberTypeCode>														

4.6.4. PartyIdentification Elements

Element Name:	PartyIdentification	minOccurs:	0	maxOccurs:	100
Description:	<p>Party identification (header). This is the container for information about the identification associated with the party.</p> <p>The following sub-element is associated with this element:</p> <div style="background-color: #e1f5fe; padding: 10px; text-align: center;"> <p>Activity party type code definitions 35 = Transmitter 30 = Filing Institution 34 = Financial Institution Where Activity Occurred 33 = Subject</p> </div>				

Element Name:	PartyIdentification	minOccurs:	0	maxOccurs:	100																																																																																								
<p>1. Transmitter Information</p> <p>a. Transmitter Control Code (TCC) (Required)</p> <table border="1"> <thead> <tr> <th>Name</th> <th>minOccurs</th> <th>maxOccurs</th> <th>Content</th> </tr> </thead> <tbody> <tr> <td>PartyIdentificationNumberText</td> <td>1</td> <td>1</td> <td>Simple</td> </tr> <tr> <td>PartyIdentificationTypeCode (Code 28)</td> <td>1</td> <td>1</td> <td>Simple</td> </tr> </tbody> </table> <p>b. Taxpayer Identification Number (TIN) (Required)</p> <table border="1"> <thead> <tr> <th>Name</th> <th>minOccurs</th> <th>maxOccurs</th> <th>Content</th> </tr> </thead> <tbody> <tr> <td>PartyIdentificationNumberText</td> <td>1</td> <td>1</td> <td>Simple</td> </tr> <tr> <td>PartyIdentificationTypeCode (Code 4)</td> <td>1</td> <td>1</td> <td>Simple</td> </tr> </tbody> </table> <p>2. Filing Institution</p> <p>a. TIN (EIN, SSN/ITIN, Foreign) (Required FinCEN SAR Part IV, Item 77-78)</p> <table border="1"> <thead> <tr> <th>Name</th> <th>minOccurs</th> <th>maxOccurs</th> <th>Content</th> </tr> </thead> <tbody> <tr> <td>PartyIdentificationNumberText (Item 77)</td> <td>1</td> <td>1</td> <td>Simple</td> </tr> <tr> <td>PartyIdentificationTypeCode (Item 78)</td> <td>1</td> <td>1</td> <td>Simple</td> </tr> </tbody> </table> <p>b. Filing institution identification (CRD, IARD, etc.) (if applicable FinCEN SAR Part IV, Item 81)</p> <table border="1"> <thead> <tr> <th>Name</th> <th>minOccurs</th> <th>maxOccurs</th> <th>Content</th> </tr> </thead> <tbody> <tr> <td>PartyIdentificationNumberText (Item 81)</td> <td>1</td> <td>1</td> <td>Simple</td> </tr> <tr> <td>PartyIdentificationTypeCode (Item 81)</td> <td>1</td> <td>1</td> <td>Simple</td> </tr> </tbody> </table> <p>c. Internal control/file number (if available FinCEN SAR Part IV, Item 88)</p> <table border="1"> <thead> <tr> <th>Name</th> <th>minOccurs</th> <th>maxOccurs</th> <th>Content</th> </tr> </thead> <tbody> <tr> <td>PartyIdentificationNumberText (Item 88)</td> <td>1</td> <td>1</td> <td>Simple</td> </tr> <tr> <td>PartyIdentificationTypeCode (Code 29)</td> <td>1</td> <td>1</td> <td>Simple</td> </tr> </tbody> </table> <p>3. Financial Institution Where Activity Occurred</p> <p>a. TIN (EIN, SSN/ITIN, Foreign) (Required FinCEN SAR Part III, Item 59-60)</p> <table border="1"> <thead> <tr> <th>Name</th> <th>minOccurs</th> <th>maxOccurs</th> <th>Content</th> </tr> </thead> <tbody> <tr> <td>PartyIdentificationNumberText (Item 59)</td> <td>0</td> <td>1</td> <td>Simple</td> </tr> <tr> <td>PartyIdentificationTypeCode (Item 60)</td> <td>1</td> <td>1</td> <td>Simple</td> </tr> <tr> <td>TINUnknownIndicator (Item 59a)</td> <td>0</td> <td>1</td> <td>Simple</td> </tr> </tbody> </table> <p><i>*If unknown is indicated, the corresponding element whose value is unknown should not be recorded; otherwise, the unknown indicator element should not be recorded.</i></p> <p>b. Financial institution identification (CRD, IARD, etc.) (if applicable FinCEN SAR Part III, Item 55)</p> <table border="1"> <thead> <tr> <th>Name</th> <th>minOccurs</th> <th>maxOccurs</th> <th>Content</th> </tr> </thead> <tbody> <tr> <td>PartyIdentificationNumberText (Item 55)</td> <td>1</td> <td>1</td> <td>Simple</td> </tr> <tr> <td>PartyIdentificationTypeCode (Item 55)</td> <td>1</td> <td>1</td> <td>Simple</td> </tr> </tbody> </table> <p>c. Internal control/file number (if available FinCEN SAR Part III, Item 66)</p>						Name	minOccurs	maxOccurs	Content	PartyIdentificationNumberText	1	1	Simple	PartyIdentificationTypeCode (Code 28)	1	1	Simple	Name	minOccurs	maxOccurs	Content	PartyIdentificationNumberText	1	1	Simple	PartyIdentificationTypeCode (Code 4)	1	1	Simple	Name	minOccurs	maxOccurs	Content	PartyIdentificationNumberText (Item 77)	1	1	Simple	PartyIdentificationTypeCode (Item 78)	1	1	Simple	Name	minOccurs	maxOccurs	Content	PartyIdentificationNumberText (Item 81)	1	1	Simple	PartyIdentificationTypeCode (Item 81)	1	1	Simple	Name	minOccurs	maxOccurs	Content	PartyIdentificationNumberText (Item 88)	1	1	Simple	PartyIdentificationTypeCode (Code 29)	1	1	Simple	Name	minOccurs	maxOccurs	Content	PartyIdentificationNumberText (Item 59)	0	1	Simple	PartyIdentificationTypeCode (Item 60)	1	1	Simple	TINUnknownIndicator (Item 59a)	0	1	Simple	Name	minOccurs	maxOccurs	Content	PartyIdentificationNumberText (Item 55)	1	1	Simple	PartyIdentificationTypeCode (Item 55)	1	1	Simple
Name	minOccurs	maxOccurs	Content																																																																																										
PartyIdentificationNumberText	1	1	Simple																																																																																										
PartyIdentificationTypeCode (Code 28)	1	1	Simple																																																																																										
Name	minOccurs	maxOccurs	Content																																																																																										
PartyIdentificationNumberText	1	1	Simple																																																																																										
PartyIdentificationTypeCode (Code 4)	1	1	Simple																																																																																										
Name	minOccurs	maxOccurs	Content																																																																																										
PartyIdentificationNumberText (Item 77)	1	1	Simple																																																																																										
PartyIdentificationTypeCode (Item 78)	1	1	Simple																																																																																										
Name	minOccurs	maxOccurs	Content																																																																																										
PartyIdentificationNumberText (Item 81)	1	1	Simple																																																																																										
PartyIdentificationTypeCode (Item 81)	1	1	Simple																																																																																										
Name	minOccurs	maxOccurs	Content																																																																																										
PartyIdentificationNumberText (Item 88)	1	1	Simple																																																																																										
PartyIdentificationTypeCode (Code 29)	1	1	Simple																																																																																										
Name	minOccurs	maxOccurs	Content																																																																																										
PartyIdentificationNumberText (Item 59)	0	1	Simple																																																																																										
PartyIdentificationTypeCode (Item 60)	1	1	Simple																																																																																										
TINUnknownIndicator (Item 59a)	0	1	Simple																																																																																										
Name	minOccurs	maxOccurs	Content																																																																																										
PartyIdentificationNumberText (Item 55)	1	1	Simple																																																																																										
PartyIdentificationTypeCode (Item 55)	1	1	Simple																																																																																										

Element Name:	PartyIdentification	minOccurs:	0	maxOccurs:	100																																																								
<table border="1"> <thead> <tr> <th>Name</th> <th>minOccurs</th> <th>maxOccurs</th> <th>Content</th> </tr> </thead> <tbody> <tr> <td>PartyIdentificationNumberText (Item 66)</td> <td>1</td> <td>1</td> <td>Simple</td> </tr> <tr> <td>PartyIdentificationTypeCode (Code 29)</td> <td>1</td> <td>1</td> <td>Simple</td> </tr> </tbody> </table> <p>4. Subject</p> <p>a. TIN/Unknown* (EIN, SSN/ITIN, Foreign) (Conditionally Required FinCEN SAR Part I, Item 16-17)</p> <table border="1"> <thead> <tr> <th>Name</th> <th>minOccurs</th> <th>maxOccurs</th> <th>Content</th> </tr> </thead> <tbody> <tr> <td>PartyIdentificationNumberText (Item 16)</td> <td>0</td> <td>1</td> <td>Simple</td> </tr> <tr> <td>PartyIdentificationTypeCode (Item 17)</td> <td>1</td> <td>1</td> <td>Simple</td> </tr> <tr> <td>TINUnknownIndicator (Item 16a)</td> <td>0</td> <td>1</td> <td>Simple</td> </tr> </tbody> </table> <p><i>*If unknown is indicated, the corresponding element whose value is unknown should not be recorded; otherwise, the unknown indicator element should not be recorded.</i></p> <p>b. Form of identification/Unknown* (Driver's license, Passport, etc.) (Conditionally Required FinCEN SAR Part I, Item 18)</p> <table border="1"> <thead> <tr> <th>Name</th> <th>minOccurs</th> <th>maxOccurs</th> <th>Content</th> </tr> </thead> <tbody> <tr> <td>IdentificationPresentUnknownIndicator (Item 18a)</td> <td>0</td> <td>1</td> <td>Simple</td> </tr> <tr> <td>OtherIssuerCountryText (Item 18g)</td> <td>0</td> <td>1</td> <td>Simple</td> </tr> <tr> <td>OtherIssuerStateText (Item 18f)</td> <td>0</td> <td>1</td> <td>Simple</td> </tr> <tr> <td>OtherPartyIdentificationTypeText (Item 18z)</td> <td>0</td> <td>1</td> <td>Simple</td> </tr> <tr> <td>PartyIdentificationNumberText (Item 18e)</td> <td>0</td> <td>1</td> <td>Simple</td> </tr> <tr> <td>PartyIdentificationTypeCode (Item 18b-d,z)</td> <td>0</td> <td>1</td> <td>Simple</td> </tr> </tbody> </table> <p><i>*If unknown is indicated for the subject form of identification, the above subsequent elements should not be recorded; Unless all information related to the subject form of identification is unknown, the unknown indicator element should not be recorded.</i></p>	Name	minOccurs	maxOccurs	Content	PartyIdentificationNumberText (Item 66)	1	1	Simple	PartyIdentificationTypeCode (Code 29)	1	1	Simple	Name	minOccurs	maxOccurs	Content	PartyIdentificationNumberText (Item 16)	0	1	Simple	PartyIdentificationTypeCode (Item 17)	1	1	Simple	TINUnknownIndicator (Item 16a)	0	1	Simple	Name	minOccurs	maxOccurs	Content	IdentificationPresentUnknownIndicator (Item 18a)	0	1	Simple	OtherIssuerCountryText (Item 18g)	0	1	Simple	OtherIssuerStateText (Item 18f)	0	1	Simple	OtherPartyIdentificationTypeText (Item 18z)	0	1	Simple	PartyIdentificationNumberText (Item 18e)	0	1	Simple	PartyIdentificationTypeCode (Item 18b-d,z)	0	1	Simple					
	Name	minOccurs	maxOccurs	Content																																																									
	PartyIdentificationNumberText (Item 66)	1	1	Simple																																																									
	PartyIdentificationTypeCode (Code 29)	1	1	Simple																																																									
	Name	minOccurs	maxOccurs	Content																																																									
	PartyIdentificationNumberText (Item 16)	0	1	Simple																																																									
	PartyIdentificationTypeCode (Item 17)	1	1	Simple																																																									
	TINUnknownIndicator (Item 16a)	0	1	Simple																																																									
	Name	minOccurs	maxOccurs	Content																																																									
	IdentificationPresentUnknownIndicator (Item 18a)	0	1	Simple																																																									
OtherIssuerCountryText (Item 18g)	0	1	Simple																																																										
OtherIssuerStateText (Item 18f)	0	1	Simple																																																										
OtherPartyIdentificationTypeText (Item 18z)	0	1	Simple																																																										
PartyIdentificationNumberText (Item 18e)	0	1	Simple																																																										
PartyIdentificationTypeCode (Item 18b-d,z)	0	1	Simple																																																										
Attribute(s)	The following attributes must be recorded for this element: <table border="1"> <thead> <tr> <th>Name</th> <th>Description</th> </tr> </thead> <tbody> <tr> <td>SeqNum</td> <td>The value recorded for this attribute must be numeric and unique. It may contain any numeric value up to 19 characters in length.</td> </tr> </tbody> </table>					Name	Description	SeqNum	The value recorded for this attribute must be numeric and unique. It may contain any numeric value up to 19 characters in length.																																																				
Name	Description																																																												
SeqNum	The value recorded for this attribute must be numeric and unique. It may contain any numeric value up to 19 characters in length.																																																												
Parent Element:	Party																																																												
Element Restriction(s):	Required. This element must be recorded for the following party types (activity level): <table border="1"> <thead> <tr> <th>Party type</th> <th>TCC (min-max)</th> <th>TIN (min-max)</th> <th>Form of ID (min-max)</th> <th>ICN (min-max)</th> </tr> </thead> <tbody> <tr> <td>Transmitter</td> <td>1-1</td> <td>1-1</td> <td>n/a</td> <td>n/a</td> </tr> <tr> <td>Filing Institution</td> <td>n/a</td> <td>1-1</td> <td>0-1</td> <td>0-1</td> </tr> <tr> <td>Financial Institution Where Activity Occurred</td> <td>n/a</td> <td>1-1</td> <td>0-1</td> <td>0-1</td> </tr> <tr> <td>Subject*</td> <td>n/a</td> <td>0-1</td> <td>0-99</td> <td>n/a</td> </tr> </tbody> </table> <p><i>*In the event that all critical subject information is unavailable, do not record the <PartyIdentification> element for the Subject (33).</i></p>					Party type	TCC (min-max)	TIN (min-max)	Form of ID (min-max)	ICN (min-max)	Transmitter	1-1	1-1	n/a	n/a	Filing Institution	n/a	1-1	0-1	0-1	Financial Institution Where Activity Occurred	n/a	1-1	0-1	0-1	Subject*	n/a	0-1	0-99	n/a																															
Party type	TCC (min-max)	TIN (min-max)	Form of ID (min-max)	ICN (min-max)																																																									
Transmitter	1-1	1-1	n/a	n/a																																																									
Filing Institution	n/a	1-1	0-1	0-1																																																									
Financial Institution Where Activity Occurred	n/a	1-1	0-1	0-1																																																									
Subject*	n/a	0-1	0-99	n/a																																																									
Value Restriction(s):	n/a																																																												
Remarks:	The batch submission will be <u>rejected</u> if any of the following conditions are true: <ul style="list-style-type: none"> The element is recorded for a party type that is not applicable to this data (see Element Restrictions for more information). 																																																												

Element Name:	PartyIdentification	minOccurs:	0	maxOccurs:	100
	<ul style="list-style-type: none"> The element is missing a "SeqNum" attribute. The element contains a "SeqNum" attribute with a duplicate or invalid value. <p>The batch submission will be accepted with warning if any of the following conditions are true:</p> <ul style="list-style-type: none"> The element is not recorded or does not contain a value for the Subject TIN and <AllCriticalSubjectInformationUnavailableIndicator> does not contain a "Y" value. The element is not recorded or does not contain a value for the Subject Form of Identification and <AllCriticalSubjectInformationUnavailableIndicator> does not contain a "Y" value. More than one identification (other than the Form of ID for the Subject) of the same type is recorded for a party within a single FinCEN SAR Activity. 				
Example:	<pre><fc2:PartyIdentification SeqNum="69"> <fc2:OtherIssuerCountryText>US</fc2:OtherIssuerCountryText> <fc2:OtherIssuerStateText>CA</fc2:OtherIssuerStateText> <fc2:OtherPartyIdentificationTypeText>Student ID</fc2:OtherPartyIdentificationTypeText> <fc2:PartyIdentificationNumberText>660623559</fc2:PartyIdentificationNumberText> <fc2:PartyIdentificationTypeCode>999</fc2:PartyIdentificationTypeCode> </fc2:PartyIdentification></pre>				

Element Name:	IdentificationPresentUnknownIndicator	minOccurs:	0	maxOccurs:	1
Description:	<p>Identification unknown (indicator). This element declares that the form of identification used to verify the identity of the subject is unknown. This element corresponds with the following item(s):</p> <ul style="list-style-type: none"> 18a. Form of identification for subject (unknown) <p><i>Please refer to Attachment C for additional information regarding the above item(s).</i></p>				
Attribute(s)	n/a				
Parent Element:	PartyIdentification				
Element Restriction(s):	Record this element when all information related to the Subject (33) form of identification is unknown; otherwise, do not record this element.				
Value Restriction(s):	The value provided must adhere to the following requirements: "Y" (to indicate Identification unknown)				
Remarks:	<p>The batch submission will be rejected if any of the following conditions are true:</p> <ul style="list-style-type: none"> The element is recorded for a party type that is not applicable to this data (see Element Restrictions for more information). The value recorded is not equal to "Y" or not equal to null. 				
Example:	<pre><fc2:IdentificationPresentUnknownIndicator>Y</fc2:IdentificationPresentUnknownIndicator></pre>				

Element Name:	OtherIssuerCountryText	minOccurs:	0	maxOccurs:	1
Description:	<p>Identification issuing country (code). This element identifies the country where the identification was issued by (or in) associated with the subject. This element corresponds with the following item(s):</p> <ul style="list-style-type: none"> 18g. Form of identification for subject – Issuing Country <p><i>Please refer to Attachment C for additional information regarding the above item(s).</i></p>				
Attribute(s)	n/a				
Parent Element:	PartyIdentification				
Element Restriction(s):	Record this element for the Subject (33) party type when the following conditions are true; otherwise, do not record this element:				
	<ul style="list-style-type: none"> The identification type is Passport or Alien registration The identification type is Driver's license/state ID or Other, and the country the identification was issued in is known 				
Value Restriction(s):	The value provided must adhere to the following requirements: Country codes (including U.S. Territory codes) must adhere to the two-letter country codes found in ISO 3166-2.				
Remarks:	The batch submission will be rejected if any of the following conditions are true:				

Element Name:	OtherIssuerCountryText	minOccurs:	0	maxOccurs:	1
	<ul style="list-style-type: none"> The element is recorded for a party type that is not applicable to this data (see Element Restrictions for more information). <p>The batch submission will be <u>accepted with warning</u> if any of the following conditions are true:</p> <ul style="list-style-type: none"> The element is not recorded or does not contain a value for the Subject when the form of identification is Passport or Alien registration. The element contains a value and identification unknown is indicated. The element contains a value that is not a valid country code State code and country code mismatch when U.S. Territory is recorded 				
Example:	<fc2:OtherIssuerCountryText>US</fc2:OtherIssuerCountryText>				

Element Name:	OtherIssuerStateText	minOccurs:	0	maxOccurs:	1
Description:	<p>Identification issuing state (code). This element identifies the state where the identification was issued by (or in) associated with the subject. This element corresponds with the following item(s):</p> <ul style="list-style-type: none"> 18f. Form of identification for subject – Issuing State <p><i>Please refer to Attachment C for additional information regarding the above item(s).</i></p>				
Attribute(s)	n/a				
Parent Element:	PartyIdentification				
Element Restriction(s):	<p>Record this element for the Subject (33) party type when the following conditions are true; otherwise, do not record this element:</p> <ul style="list-style-type: none"> The identification type is Driver's license/state ID and the corresponding country is US, CA, MX, or a U.S. Territory The identification type is Other and the identification was issued by or in a known state/province/territory of the U.S., a U.S. Territory, Canada, or Mexico. The identification type is Other and the identification was not issues by a national government. 				
Value Restriction(s):	<p>The value provided must adhere to the following requirements: United States state/territory codes must adhere to the two-letter codes used by the United States Postal Service when the country is equal to US or a U.S. Territory. If a U.S. Territory is recorded for the country, it must also be recorded for the state. Canadian province/territory codes must adhere to the two-letter codes used by the Canadian Post Corporation when the country is equal to CA. Mexican state/federal district codes must adhere to the standards of ISO 3166-2:MX when the country is equal to MX.</p>				
Remarks:	<p>The batch submission will be <u>rejected</u> if any of the following conditions are true:</p> <ul style="list-style-type: none"> The element is recorded for a party type that is not applicable to this data (see Element Restrictions for more information). <p>The batch submission will be <u>accepted with warning</u> if any of the following conditions are true:</p> <ul style="list-style-type: none"> The element is not recorded or does not contain a value for the Subject when the form of identification is Driver's license/State ID. The element contains a value and identification unknown is indicated. The element contains a value that is not a valid state code. State code and country code mismatch when U.S. Territory is recorded. 				
Example:	<fc2:OtherIssuerStateText>CA</fc2:OtherIssuerStateText>				

Element Name:	OtherPartyIdentificationTypeText	minOccurs:	0	maxOccurs:	1
Description:	<p>Identification type other description (text). This element identifies the other identification type associated with the party. This element corresponds with the following item(s):</p> <ul style="list-style-type: none"> 18z. Form of identification for subject – Other (description) <p><i>Please refer to Attachment C for additional information regarding the above item(s).</i></p>				
Attribute(s)	n/a				
Parent Element:	PartyIdentification				

Element Name:	OtherPartyIdentificationTypeText	minOccurs:	0	maxOccurs:	1
Element Restriction(s):	Record this element for the Subject (33) party type and "Other" is declared for the form of identification type; otherwise, do not record this element.				
Value Restriction(s):	The value provided must adhere to the following requirements: 50 characters or less				
Remarks:	<p>The batch submission will be <u>rejected</u> if any of the following conditions are true:</p> <ul style="list-style-type: none"> The element is recorded for a party type that is not applicable to this data (see Element Restrictions for more information). <p>The batch submission will be <u>accepted with warning</u> if any of the following conditions are true:</p> <ul style="list-style-type: none"> The element is not recorded or does not contain a value for the Subject when the form of identification is Other. The element contains a value and identification unknown is indicated. 				
Example:	<fc2:OtherPartyIdentificationTypeText>Student ID</fc2:OtherPartyIdentificationTypeText>				

Element Name:	PartyIdentificationNumberText	minOccurs:	0	maxOccurs:	1
Description:	<p>Identification number (text). This element identifies the form of identification number associated with the party. This element corresponds with the following item(s):</p> <ul style="list-style-type: none"> Transmitter <ul style="list-style-type: none"> Transmitter Control Code (TCC) number Taxpayer Identification Number (TIN) number Filing Institution <ul style="list-style-type: none"> 77. TIN (EIN, SSN/ITIN, Foreign) number 81. Filing institution identification (CRD, IARD, etc.) number (if known) 88. Internal control/file number (if known) Financial Institution Where Activity Occurred <ul style="list-style-type: none"> 59. TIN (EIN, SSN/ITIN, Foreign) number (if known) 55. Financial institution identification (CRD, IARD, etc.) number (if known) 66. Internal control/file number (if known) Subject <ul style="list-style-type: none"> 16. TIN (EIN, SSN/ITIN, Foreign) number (if known) 18. Form of identification (Driver's license/State ID, Passport, etc.) number (if known) <p><i>Please refer to Attachment C for additional information regarding the above item(s).</i></p>				
Attribute(s)	n/a				
Parent Element:	PartyIdentification				
Element Restriction(s):	Conditionally Required. Record this element for the above party types and conditions, otherwise, do not record this element. If unknown is indicated for the Financial Institution TIN or the Subject TIN, record the corresponding unknown element with a "Y" value and do not record this element. For Form of Identification do not record this element when unknown is indicated but only record the corresponding unknown element with a "Y" when all Form of Identification data are unknown.				
Value Restriction(s):	<p>The value provided must adhere to the following requirements by party type:</p> <ul style="list-style-type: none"> Transmitter (35) <ul style="list-style-type: none"> TCC = 8 characters equal to "TBSATEST" (when submitting in the BSA E-Filing User Test System) or "PBSA8180" (when submitting in the BSA E-Filing Production System) TIN = 25 characters or less Filing institution (30) and Financial institution where activity occurred (34) <ul style="list-style-type: none"> EIN/SSN/ITIN = 9 numeric characters Foreign TIN = 25 characters or less Identification number (CRD, IARD, etc.) = 10 characters or less Internal Control Number = 20 characters or less Subject (33) <ul style="list-style-type: none"> EIN/SSN/ITIN = 9 numeric characters 				

Element Name:	PartyIdentificationNumberText	minOccurs:	0	maxOccurs:	1
	<ul style="list-style-type: none"> o Foreign TIN = 25 characters or less o Identification (Driver's license, Passport, etc.) = 24 characters or less <p>All identification numbers must be entered as a single alpha/numeric text string without formatting or special characters such as, for example, spaces, hyphens, or periods; however, asterisks within the identification number are accepted for the subject's form of identification. Cannot be consecutive string of the same number or an incremental string such as 123456789.</p>				
Remarks:	<p>The batch submission will be <u>rejected</u> if any of the following conditions are true:</p> <ul style="list-style-type: none"> • The element is recorded for a party type that is not applicable to this data (see Element Restrictions for more information). • The element is not recorded or does not contain a value for the filing institution TIN. • The element is not recorded or does not contain a value for the financial institution where activity occurred TIN and unknown is not indicated. <p>The batch submission will be <u>accepted with warning</u> if any of the following conditions are true:</p> <ul style="list-style-type: none"> • The value recorded for the EIN or SSN/ITIN is an invalid number string. • The element contains a value for the subject form of identification and unknown is indicated. 				
Example:	<fc2:PartyIdentificationNumberText>660623559</fc2:PartyIdentificationNumberText>				

Element Name:	PartyIdentificationTypeCode	minOccurs:	0	maxOccurs:	1																																		
Description:	<p>Identification type (code). This element identifies the type of identification associated with the party. This element corresponds with the following item(s):</p> <ul style="list-style-type: none"> • Transmitter <ul style="list-style-type: none"> o Transmitter Control Code (TCC) type o Taxpayer Identification Number (TIN) type • Filing Institution <ul style="list-style-type: none"> o 78. TIN (EIN, SSN/ITIN, Foreign) type o 81. Filing institution identification (CRD, IARD, etc.) type o 88. Internal control/file number type • Financial Institution Where Activity Occurred <ul style="list-style-type: none"> o 60. TIN (EIN, SSN/ITIN, Foreign) type o 55. Financial institution identification (CRD, IARD, etc.) type o 66. Internal control/file number type • Subject <ul style="list-style-type: none"> o 17. TIN (EIN, SSN/ITIN, Foreign) type o 18. Form of identification (Driver's license/State ID, Passport, etc.) type <p><i>Please refer to Attachment C for additional information regarding the above item(s).</i></p>																																						
Attribute(s)	n/a																																						
Parent Element:	PartyIdentification																																						
Element Restriction(s):	Required. This element must be recorded for the above party types/conditions; otherwise, do not record this element.																																						
Value Restriction(s):	<p>The value provided must adhere to the following requirements: Identify the identification type by recording the appropriate code from the list below (by party type at the activity level):</p> <table border="1"> <thead> <tr> <th rowspan="2">Code</th> <th rowspan="2">Description</th> <th colspan="4">Party Type (Code)</th> </tr> <tr> <th>35</th> <th>30</th> <th>34</th> <th>33</th> </tr> </thead> <tbody> <tr> <td>4</td> <td>Taxpayer Identification Number (TIN)</td> <td>•</td> <td></td> <td></td> <td></td> </tr> <tr> <td>28</td> <td>Transmitter Control Code (TCC)</td> <td>•</td> <td></td> <td></td> <td></td> </tr> <tr> <td>2</td> <td>Employer Identification Number (EIN)</td> <td></td> <td>•</td> <td>•</td> <td>•</td> </tr> <tr> <td>1</td> <td>Social Security Number (SSN)/Individual Taxpayer Identification Number (ITIN)</td> <td></td> <td>•</td> <td>•</td> <td>•</td> </tr> </tbody> </table>					Code	Description	Party Type (Code)				35	30	34	33	4	Taxpayer Identification Number (TIN)	•				28	Transmitter Control Code (TCC)	•				2	Employer Identification Number (EIN)		•	•	•	1	Social Security Number (SSN)/Individual Taxpayer Identification Number (ITIN)		•	•	•
Code	Description	Party Type (Code)																																					
		35	30	34	33																																		
4	Taxpayer Identification Number (TIN)	•																																					
28	Transmitter Control Code (TCC)	•																																					
2	Employer Identification Number (EIN)		•	•	•																																		
1	Social Security Number (SSN)/Individual Taxpayer Identification Number (ITIN)		•	•	•																																		

Element Name:	PartyIdentificationTypeCode	minOccurs:	0	maxOccurs:	1	
	9	Foreign Taxpayer Identification Number (TIN)		•	•	•
	10	Central Registration Depository (CRD) number		•	•	
	11	Investment Adviser Registration (IARD) number		•	•	
	12	National Futures Association (NFA ID) number		•	•	
	14	Research, Statistics, Supervision, and Discount (RSSD) number		•	•	
	13	Securities and Exchange Commission (SEC) number		•	•	
	32	National Association of Insurance Commissioners (NAIC) number		•	•	
	33	National Mortgage Licensing System (NMLS) number		•	•	
	29	Internal control/file number		•	•	
	5	Driver's license/State ID				•
	6	Passport				•
	7	Alien registration				•
	999	Other Identification				•
Remarks:	The batch submission will be <u>rejected</u> if any of the following conditions are true: <ul style="list-style-type: none"> • The element is not recorded and the <PartyIdentificationNumberText> contains a value. • The element contains a value not equal to one of the approved codes listed above. • The element is recorded but without a value (i.e. the value is null). • The element contains a value that is not valid for the associated party type. 					
Example:	<fc2:PartyIdentificationTypeCode>999</fc2:PartyIdentificationTypeCode>					

Element Name:	TINUnknownIndicator	minOccurs:	0	maxOccurs:	1
Description:	TIN unknown (indicator). This element declares that the TIN associated with the party is unknown. This element corresponds with the following item(s): <ul style="list-style-type: none"> • Subject: 16a. TIN (unknown) • Financial Institution Where Activity Occurred: 59a. TIN (unknown) Please refer to Attachment C for additional information regarding the above item(s).				
Attribute(s)	n/a				
Parent Element:	PartyIdentification				
Element Restriction(s):	Conditionally Required. Record this element for the Financial institution where activity occurred (34) and Subject (33) part types when the TIN is unknown; otherwise, do not record this element.				
Value Restriction(s):	The value provided must adhere to the following requirements: "Y" (to indicate TIN unknown)				
Remarks:	The batch submission will be <u>rejected</u> if any of the following conditions are true: <ul style="list-style-type: none"> • The element is recorded for a party type that is not applicable to this data (see Element Restrictions for more information). • The value recorded is not equal to "Y" or not equal to null. 				
Example:	<fc2:PartyIdentification SeqNum="69"> <fc2:TINUnknownIndicator>Y</fc2:TINUnknownIndicator> </fc2:PartyIdentification>				

4.6.5. OrganizationClassificationTypeSubtype Elements

Element Name:	OrganizationClassificationTypeSubtype	minOccurs:	0	maxOccurs:	15
Description:	Institution type/subtype (header). This is the container form information about the type and subtype of institution associated with the party.				

Element Name:	OrganizationClassificationTypeSubtype	minOccurs:	0	maxOccurs:	15																																								
	<p>The following sub-element is associated with this element:</p> <div style="background-color: #e1f5fe; padding: 10px; text-align: center;"> <p>Activity party type code definitions 30 = Filing Institution 34 = Financial Institution Where Activity Occurred</p> </div> <ol style="list-style-type: none"> Filing Institution Information: Type of financial institution (Required FinCEN SAR Part IV, Items 79-80) <table border="1" style="width: 100%; border-collapse: collapse;"> <thead> <tr> <th style="background-color: #e1f5fe;">Name</th> <th>minOccurs</th> <th>maxOccurs</th> <th>Content</th> </tr> </thead> <tbody> <tr> <td>OrganizationSubtypeID (Item 80a-n, z)</td> <td style="text-align: center;">0</td> <td style="text-align: center;">1</td> <td>Simple</td> </tr> <tr> <td>OrganizationTypeID (Item 79a-g, z)</td> <td style="text-align: center;">1</td> <td style="text-align: center;">1</td> <td>Simple</td> </tr> <tr> <td>OtherOrganizationSubTypeText (Item 80z)</td> <td style="text-align: center;">0</td> <td style="text-align: center;">1</td> <td>Simple</td> </tr> <tr> <td>OtherOrganizationTypeText (Item 79z)</td> <td style="text-align: center;">0</td> <td style="text-align: center;">1</td> <td>Simple</td> </tr> </tbody> </table> Financial Institution Where Activity Occurred: Type of financial institution (Required FinCEN SAR Part III, Items 51, 53-54) <table border="1" style="width: 100%; border-collapse: collapse;"> <thead> <tr> <th style="background-color: #e1f5fe;">Name</th> <th>minOccurs</th> <th>maxOccurs</th> <th>Content</th> </tr> </thead> <tbody> <tr> <td>OrganizationSubtypeID (Items 53a-c, z / 54a-k, z)</td> <td style="text-align: center;">0</td> <td style="text-align: center;">1</td> <td>Simple</td> </tr> <tr> <td>OrganizationTypeID (Item 51a-g, z)</td> <td style="text-align: center;">1</td> <td style="text-align: center;">1</td> <td>Simple</td> </tr> <tr> <td>OtherOrganizationSubTypeText (Items 53z / 54z)</td> <td style="text-align: center;">0</td> <td style="text-align: center;">1</td> <td>Simple</td> </tr> <tr> <td>OtherOrganizationTypeText (Item 51z)</td> <td style="text-align: center;">0</td> <td style="text-align: center;">1</td> <td>Simple</td> </tr> </tbody> </table> 					Name	minOccurs	maxOccurs	Content	OrganizationSubtypeID (Item 80a-n, z)	0	1	Simple	OrganizationTypeID (Item 79a-g, z)	1	1	Simple	OtherOrganizationSubTypeText (Item 80z)	0	1	Simple	OtherOrganizationTypeText (Item 79z)	0	1	Simple	Name	minOccurs	maxOccurs	Content	OrganizationSubtypeID (Items 53a-c, z / 54a-k, z)	0	1	Simple	OrganizationTypeID (Item 51a-g, z)	1	1	Simple	OtherOrganizationSubTypeText (Items 53z / 54z)	0	1	Simple	OtherOrganizationTypeText (Item 51z)	0	1	Simple
Name	minOccurs	maxOccurs	Content																																										
OrganizationSubtypeID (Item 80a-n, z)	0	1	Simple																																										
OrganizationTypeID (Item 79a-g, z)	1	1	Simple																																										
OtherOrganizationSubTypeText (Item 80z)	0	1	Simple																																										
OtherOrganizationTypeText (Item 79z)	0	1	Simple																																										
Name	minOccurs	maxOccurs	Content																																										
OrganizationSubtypeID (Items 53a-c, z / 54a-k, z)	0	1	Simple																																										
OrganizationTypeID (Item 51a-g, z)	1	1	Simple																																										
OtherOrganizationSubTypeText (Items 53z / 54z)	0	1	Simple																																										
OtherOrganizationTypeText (Item 51z)	0	1	Simple																																										
Attribute(s)	<p>The following attributes must be recorded for this element:</p> <table border="1" style="width: 100%; border-collapse: collapse;"> <thead> <tr> <th style="background-color: #e1f5fe;">Name</th> <th>Description</th> </tr> </thead> <tbody> <tr> <td>SeqNum</td> <td>The value recorded for this attribute must be numeric and unique. It may contain any numeric value up to 19 characters in length.</td> </tr> </tbody> </table>					Name	Description	SeqNum	The value recorded for this attribute must be numeric and unique. It may contain any numeric value up to 19 characters in length.																																				
Name	Description																																												
SeqNum	The value recorded for this attribute must be numeric and unique. It may contain any numeric value up to 19 characters in length.																																												
Parent Element:	Party																																												
Element Restriction(s):	<p>Required. This element must be recorded for the following party types (activity level):</p> <table border="1" style="width: 100%; border-collapse: collapse;"> <thead> <tr> <th style="background-color: #e1f5fe;">Party type</th> <th style="background-color: #e1f5fe;">Institution type/subtype (min-max)</th> </tr> </thead> <tbody> <tr> <td>Filing Institution</td> <td style="text-align: center;">1-15</td> </tr> <tr> <td>Financial Institution Where Activity Occurred</td> <td style="text-align: center;">1-12</td> </tr> </tbody> </table> <p>*If the Filing institution (30) and/or Financial institution where activity occurred (34) is a Securities and Futures institution (or individual) and the institution/individual can be classified as more than one type of Securities and Futures institution, the <OrganizationClassificationTypeSubtype> element may be recorded multiple times in order to identify all of the associated Securities and Futures subtypes (in which case each occurrence would identify the same type of institution with the applicable subtype); however, if the type of institution is not equal to Securities and Futures, then the <OrganizationClassificationTypeSubtype> should only be recorded once per these party types.</p>					Party type	Institution type/subtype (min-max)	Filing Institution	1-15	Financial Institution Where Activity Occurred	1-12																																		
Party type	Institution type/subtype (min-max)																																												
Filing Institution	1-15																																												
Financial Institution Where Activity Occurred	1-12																																												
Value Restriction(s):	n/a																																												
Remarks:	<p>The batch submission will be <u>rejected</u> if any of the following conditions are true:</p> <ul style="list-style-type: none"> The element is recorded for a party type that is not applicable to this data (see Element Restrictions for more information). The element is missing a "SeqNum" attribute. The element contains a "SeqNum" attribute with a duplicate or invalid value. 																																												

Element Name:	OrganizationClassificationTypeSubtype	minOccurs:	0	maxOccurs:	15
	The batch submission will be <u>accepted with warning</u> if any of the following conditions are true: <ul style="list-style-type: none"> The element is not recorded for the Financial institution where activity occurred and/or the Filing institution. 				
Example:	<pre><fc2:OrganizationClassificationTypeSubtype SeqNum="52"> <fc2:OrganizationSubtypeID>533</fc2:OrganizationSubtypeID> <fc2:OrganizationTypeID>5</fc2:OrganizationTypeID> </fc2:OrganizationClassificationTypeSubtype></pre>				

Element Name:	OrganizationSubtypeID	minOccurs:	0	maxOccurs:	1																																																																		
Description:	Institution subtype (code). This element identifies the specific type of gaming or securities/futures institution. This element corresponds with the following item(s): <ul style="list-style-type: none"> Filing institution <ul style="list-style-type: none"> 80a-n, z. Type of Securities and Futures institution or individual Financial institution where activity occurred <ul style="list-style-type: none"> 53a-c, z. Type of Gaming institution 54a-k, z. Type of Securities and Futures institution or individual <i>Please refer to Attachment C for additional information regarding the above item(s).</i>																																																																						
Attribute(s)	n/a																																																																						
Parent Element:	OrganizationClassificationTypeSubtype																																																																						
Element Restriction(s):	Conditionally Required. Record this element for the following party types and conditions; otherwise, do not record this element: <ul style="list-style-type: none"> Filing institution (30) and the type of institution is Securities/Futures (5) Financial institution where activity occurred (34) and the type of institution is either Casino/Card club (1) or Securities/Futures (5) 																																																																						
Value Restriction(s):	The value provided must adhere to the following requirements: <ul style="list-style-type: none"> If the party type is associated with the Filing institution (30) or Filing institution where activity occurred (34) and the type of institution is Securities/Futures (5), then select from the list of codes to describe the institution subtype: <table border="1" data-bbox="441 1167 1409 1852"> <thead> <tr> <th rowspan="2">Code</th> <th rowspan="2">Description</th> <th colspan="2">Party Type (Code)</th> </tr> <tr> <th>30</th> <th>34</th> </tr> </thead> <tbody> <tr><td>535</td><td>Clearing broker-securities</td><td>•</td><td>•</td></tr> <tr><td>534</td><td>CPO/CTA</td><td>•</td><td></td></tr> <tr><td>541</td><td>Execution-only broker securities</td><td>•</td><td>•</td></tr> <tr><td>508</td><td>Futures Commission Merchant</td><td>•</td><td>•</td></tr> <tr><td>504</td><td>Holding Company</td><td>•</td><td>•</td></tr> <tr><td>513</td><td>Introducing broker-commodity</td><td>•</td><td>•</td></tr> <tr><td>540</td><td>Introducing broker-securities</td><td>•</td><td>•</td></tr> <tr><td>514</td><td>Investment adviser</td><td>•</td><td>•</td></tr> <tr><td>539</td><td>Investment company</td><td>•</td><td>•</td></tr> <tr><td>533</td><td>Retail foreign exchange dealer</td><td>•</td><td>•</td></tr> <tr><td>542</td><td>Self-clearing broker-securities</td><td>•</td><td>•</td></tr> <tr><td>528</td><td>SRO futures</td><td>•</td><td></td></tr> <tr><td>529</td><td>SRO securities</td><td>•</td><td></td></tr> <tr><td>503</td><td>Subsidiary of financial/bank holding company</td><td>•</td><td>•</td></tr> <tr><td>5999</td><td>Other</td><td>•</td><td>•</td></tr> </tbody> </table>					Code	Description	Party Type (Code)		30	34	535	Clearing broker-securities	•	•	534	CPO/CTA	•		541	Execution-only broker securities	•	•	508	Futures Commission Merchant	•	•	504	Holding Company	•	•	513	Introducing broker-commodity	•	•	540	Introducing broker-securities	•	•	514	Investment adviser	•	•	539	Investment company	•	•	533	Retail foreign exchange dealer	•	•	542	Self-clearing broker-securities	•	•	528	SRO futures	•		529	SRO securities	•		503	Subsidiary of financial/bank holding company	•	•	5999	Other	•	•
Code	Description	Party Type (Code)																																																																					
		30	34																																																																				
535	Clearing broker-securities	•	•																																																																				
534	CPO/CTA	•																																																																					
541	Execution-only broker securities	•	•																																																																				
508	Futures Commission Merchant	•	•																																																																				
504	Holding Company	•	•																																																																				
513	Introducing broker-commodity	•	•																																																																				
540	Introducing broker-securities	•	•																																																																				
514	Investment adviser	•	•																																																																				
539	Investment company	•	•																																																																				
533	Retail foreign exchange dealer	•	•																																																																				
542	Self-clearing broker-securities	•	•																																																																				
528	SRO futures	•																																																																					
529	SRO securities	•																																																																					
503	Subsidiary of financial/bank holding company	•	•																																																																				
5999	Other	•	•																																																																				

Element Name:	OrganizationSubtypeID	minOccurs:	0	maxOccurs:	1										
	<ul style="list-style-type: none"> If the party type is associated with the Financial institution where activity occurred (34) and the type of institution is Casino/Card club (1), then select from the list of codes to describe the institution subtype: <table border="1"> <thead> <tr> <th>Code</th> <th>Description</th> </tr> </thead> <tbody> <tr> <td>101</td> <td>State casino</td> </tr> <tr> <td>102</td> <td>Tribal casino</td> </tr> <tr> <td>103</td> <td>Card club</td> </tr> <tr> <td>1999</td> <td>Other</td> </tr> </tbody> </table>					Code	Description	101	State casino	102	Tribal casino	103	Card club	1999	Other
Code	Description														
101	State casino														
102	Tribal casino														
103	Card club														
1999	Other														
Remarks:	<p>The batch submission will be <u>rejected</u> if any of the following conditions are true:</p> <ul style="list-style-type: none"> The element is recorded but without a value (i.e. the value is null). The element contains a value not equal to one of the approved codes listed above. The element contains a value but the institution type is not equal to Casino/Card club or Securities and Futures. The value recorded conflicts with the institution type recorded (e.g. State Casino recorded for Securities and Futures institution) The element is not recorded for the filing institution and the institution type is equal to Securities and Futures. The element is not recorded for the financial institution where activity occurred and the institution type is equal to Casino/Card club or Securities and Futures. The element contains a value that has already been recorded for the Activity. 														
Example:	<fc2:OrganizationSubtypeID>103</fc2:OrganizationSubtypeID>														

Element Name:	OrganizationTypeID	minOccurs:	1	maxOccurs:	1																		
Description:	<p>Institution type (code). This element identifies the type of institution. This element corresponds with the following item(s):</p> <ul style="list-style-type: none"> 79a-g, z. Type of financial institution: Filing institution 51a-g, z. Type of financial institution: Financial institution where activity occurred <p><i>Please refer to Attachment C for additional information regarding the above item(s).</i></p>																						
Attribute(s)	n/a																						
Parent Element:	OrganizationClassificationTypeSubtype																						
Element Restriction(s):	Required. This element must be recorded when the parent element is recorded.																						
Value Restriction(s):	<p>The value provided must adhere to the following requirements: Identify the institution type by recording the appropriate code from the list below:</p> <table border="1"> <thead> <tr> <th>Code</th> <th>Description</th> </tr> </thead> <tbody> <tr> <td>1</td> <td>Casino/Card club</td> </tr> <tr> <td>2</td> <td>Depository institution</td> </tr> <tr> <td>3</td> <td>Insurance company</td> </tr> <tr> <td>4</td> <td>MSB (Money Service Business)</td> </tr> <tr> <td>5</td> <td>Securities/Futures</td> </tr> <tr> <td>11</td> <td>Loan or Finance Company</td> </tr> <tr> <td>12</td> <td>Housing GSE (Government Sponsored Enterprise)</td> </tr> <tr> <td>999</td> <td>Other</td> </tr> </tbody> </table>					Code	Description	1	Casino/Card club	2	Depository institution	3	Insurance company	4	MSB (Money Service Business)	5	Securities/Futures	11	Loan or Finance Company	12	Housing GSE (Government Sponsored Enterprise)	999	Other
Code	Description																						
1	Casino/Card club																						
2	Depository institution																						
3	Insurance company																						
4	MSB (Money Service Business)																						
5	Securities/Futures																						
11	Loan or Finance Company																						
12	Housing GSE (Government Sponsored Enterprise)																						
999	Other																						
Remarks:	The batch submission will be rejected if any of the following conditions are true:																						

Element Name:	OrganizationTypeID	minOccurs:	1	maxOccurs:	1
	<ul style="list-style-type: none"> The element is recorded but without a value (i.e. the value is null). The element contains a value not equal to one of the approved codes listed above. 				
Example:	<fc2:OrganizationTypeID>1</fc2:OrganizationTypeID>				

Element Name:	OtherOrganizationSubTypeText	minOccurs:	0	maxOccurs:	1
Description:	<p>Institution subtype other (description). This element identifies the other type of gaming or securities/futures institution. This element corresponds with the following item(s):</p> <ul style="list-style-type: none"> Filing institution <ul style="list-style-type: none"> 80z. Type of Securities and Futures institution or individual (other description) Financial institution where activity occurred <ul style="list-style-type: none"> 53z. Type of Gaming institution (other description) 54z. Type of Securities and Futures institution or individual (other description) <p><i>Please refer to Attachment C for additional information regarding the above item(s).</i></p>				
Attribute(s)	n/a				
Parent Element:	OrganizationClassificationTypeSubtype				
Element Restriction(s):	<p>Conditionally Required. Record this element for the following party types and conditions; otherwise, do not record this element:</p> <ul style="list-style-type: none"> Filing institution (30), the type of institution is Securities/Futures (5), and the <OrganizationSubTypeID> element contains the value "5999" (Other) Financial institution where activity occurred (34) and: <ul style="list-style-type: none"> The type of institution is Casino/Card club (1) and the <OrganizationSubTypeID> element contains the value "1999" (Other) The type of institution is Securities/Futures (5) and the <OrganizationSubTypeID> element contains the value "5999" (Other) 				
Value Restriction(s):	The value provided must adhere to the following requirements: 50 characters or less.				
Remarks:	<p>The batch submission will be <u>accepted with warning</u> if any of the following conditions are true:</p> <ul style="list-style-type: none"> The element is not recorded or does not contain a value and the institution subtype is equal to Other. The element is recorded with a value but the institution subtype is not equal to Other. 				
Example:	<fc2:OtherOrganizationSubTypeText>other description</fc2:OtherOrganizationSubTypeText>				

Element Name:	OtherOrganizationTypeText	minOccurs:	0	maxOccurs:	1
Description:	<p>Institution type other (description). This element identifies the description of the other gaming or securities/futures institution. This element corresponds with the following item(s):</p> <ul style="list-style-type: none"> 79z. Type of financial institution: Filing institution (other description) 51z. Type of financial institution: Financial institution where activity occurred (other description) <p><i>Please refer to Attachment C for additional information regarding the above item(s).</i></p>				
Attribute(s)	n/a				
Parent Element:	OrganizationClassificationTypeSubtype				
Element Restriction(s):	<p>Conditionally Required. Record this element for the following party types and conditions; otherwise, do not record this element:</p> <ul style="list-style-type: none"> Filing institution (30) and the <OrganizationTypeID> element contains the value "999" (Other) Financial institution where activity occurred (34) and the <OrganizationTypeID> element contains the value "999" (Other) 				
Value Restriction(s):	The value provided must adhere to the following requirements: 50 characters or less.				
Remarks:	The batch submission will be <u>accepted with warning</u> if any of the following conditions are true:				

Element Name:	OtherOrganizationTypeText	minOccurs:	0	maxOccurs:	1
	<ul style="list-style-type: none"> The element is not recorded or does not contain a value and the institution type is equal to Other. The element is recorded with a value but the institution type is not equal to Other. 				
Example:	<fc2:OtherOrganizationTypeText>other description</fc2:OtherOrganizationTypeText>				

4.6.6. PartyOccupationBusiness Elements

Element Name:	PartyOccupationBusiness	minOccurs:	0	maxOccurs:	1												
Description:	<p>Occupation or type of business (header). This is the container for information about the occupation or type of business of the subject.</p> <p>The following sub-element is associated with this element:</p> <div style="background-color: #e1f5fe; padding: 10px; text-align: center;"> <p>Activity party type code definitions 33 = Subject</p> </div> <p>1. Subject: Occupation or type of business (if available FinCEN SAR Part I, Item 10/10a)</p> <table border="1" style="width: 100%; border-collapse: collapse;"> <thead> <tr> <th style="width: 60%;">Name</th> <th style="width: 10%;">minOccurs</th> <th style="width: 10%;">maxOccurs</th> <th style="width: 20%;">Content</th> </tr> </thead> <tbody> <tr> <td>NAICSCode (Item 10a)</td> <td style="text-align: center;">0</td> <td style="text-align: center;">1</td> <td>Simple</td> </tr> <tr> <td>OccupationBusinessText (Item 10)</td> <td style="text-align: center;">0</td> <td style="text-align: center;">1</td> <td>Simple</td> </tr> </tbody> </table> <p><i>*If the <PartyOccupationBusiness> element is recorded for the Subject (33), then at least one of the above elements should be recorded with a valid value.</i></p>					Name	minOccurs	maxOccurs	Content	NAICSCode (Item 10a)	0	1	Simple	OccupationBusinessText (Item 10)	0	1	Simple
Name	minOccurs	maxOccurs	Content														
NAICSCode (Item 10a)	0	1	Simple														
OccupationBusinessText (Item 10)	0	1	Simple														
Attribute(s)	<p>The following attributes must be recorded for this element:</p> <table border="1" style="width: 100%; border-collapse: collapse;"> <thead> <tr> <th style="width: 20%;">Name</th> <th>Description</th> </tr> </thead> <tbody> <tr> <td>SeqNum</td> <td>The value recorded for this attribute must be numeric and unique. It may contain any numeric value up to 19 characters in length.</td> </tr> </tbody> </table>					Name	Description	SeqNum	The value recorded for this attribute must be numeric and unique. It may contain any numeric value up to 19 characters in length.								
Name	Description																
SeqNum	The value recorded for this attribute must be numeric and unique. It may contain any numeric value up to 19 characters in length.																
Parent Element:	Party																
Element Restriction(s):	Record this element when the occupation/type of business and/or NAICS Code is known for the Subject (33) party type; otherwise, do not record this element.																
Value Restriction(s):	n/a																
Remarks:	<p>The batch submission will be <u>rejected</u> if any of the following conditions are true:</p> <ul style="list-style-type: none"> The element is recorded for a party type that is not applicable to this data (see Element Restrictions for more information). The element is missing a "SeqNum" attribute. The element contains a "SeqNum" attribute with a duplicate or invalid value. 																
Example:	<pre><fc2:PartyOccupationBusiness SeqNum="72"> <fc2:NAICSCode>7548</fc2:NAICSCode> <fc2:OccupationBusinessText>Mechanic</fc2:OccupationBusinessText> </fc2:PartyOccupationBusiness></pre>																

Element Name:	NAICSCode	minOccurs:	0	maxOccurs:	1
Description:	<p>NAICS Code (text). This element identifies the North American Industry Classification System (NAICS) code for the occupation or type of business of the subject. This element corresponds with the following item(s):</p> <ul style="list-style-type: none"> 10a. NAICS Code: Subject <p><i>Please refer to Attachment C for additional information regarding the above item(s).</i></p>				

Element Name:	NAICSCode	minOccurs:	0	maxOccurs:	1
Attribute(s)	n/a				
Parent Element:	PartyOccupationBusiness				
Element Restriction(s):	Record this element when known and the party type is associated with the Subject (33); otherwise, do not record this element.				
Value Restriction(s):	The value provided must adhere to the following requirements: 3-6 digit numeric characters. Use the list of NAICS Codes authorized for use in the FinCEN SAR located on the BSA E-Filing Web Site (http://bsaeiling.fincen.treas.gov) or from the U.S. Census Bureau NAICS list. Select a code that most closely relates to the occupation or type of business recorded for the subject in the <OccupationBusinessText> element.				
Remarks:	n/a				
Example:	<fc2:NAICSCode>7548</fc2:NAICSCode>				

Element Name:	OccupationBusinessText	minOccurs:	0	maxOccurs:	1
Description:	Occupation or type of business (description). This element identifies the description of the occupation, profession, or type of business of the subject. This element corresponds with the following item(s): <ul style="list-style-type: none"> 10. Occupation or type of business: Subject <i>Please refer to Attachment C for additional information regarding the above item(s).</i>				
Attribute(s)	n/a				
Parent Element:	PartyOccupationBusiness				
Element Restriction(s):	Record this element when the party type is associated with the Subject (33) and the subject's occupation, profession, or type of business is known; otherwise, do not record this element.				
Value Restriction(s):	The value provided must adhere to the following requirements: 30 characters or less				
Remarks:	n/a				
Example:	<fc2:OccupationBusinessText>Mechanic</fc2:OccupationBusinessText>				

4.6.7. ElectronicAddress Elements

Element Name:	ElectronicAddress	minOccurs:	0	maxOccurs:	198																				
Description:	<p>Electronic address (header). This is the container for information about the subject's e-mail address or website URL (Uniform Resource Locator).</p> <p>The following sub-element is associated with this element:</p> <div style="background-color: #e1f5fe; padding: 10px; text-align: center;"> <p>Activity party type code definitions 33 = Subject</p> </div> <ol style="list-style-type: none"> 1. Subject: <ol style="list-style-type: none"> a. E-mail address (if available FinCEN SAR Part I, Item 22) <table border="1" style="width: 100%; border-collapse: collapse;"> <thead> <tr> <th style="width: 60%;">Name</th> <th style="width: 10%;">minOccurs</th> <th style="width: 10%;">maxOccurs</th> <th style="width: 20%;">Content</th> </tr> </thead> <tbody> <tr> <td>ElectronicAddressText (Item 22)</td> <td style="text-align: center;">1</td> <td style="text-align: center;">1</td> <td>Simple</td> </tr> <tr> <td>ElectronicAddressTypeCode (Code E)</td> <td style="text-align: center;">1</td> <td style="text-align: center;">1</td> <td>Simple</td> </tr> </tbody> </table> <p><i>*If the <ElectronicAddress> element is recorded for the Subject's (33) e-mail address, then the above elements should be recorded with a valid value for each.</i></p> b. Website (URL) address (if available FinCEN SAR Part I, Item 22a) <table border="1" style="width: 100%; border-collapse: collapse;"> <thead> <tr> <th style="width: 60%;">Name</th> <th style="width: 10%;">minOccurs</th> <th style="width: 10%;">maxOccurs</th> <th style="width: 20%;">Content</th> </tr> </thead> <tbody> <tr> <td>ElectronicAddressText (Item 22a)</td> <td style="text-align: center;">1</td> <td style="text-align: center;">1</td> <td>Simple</td> </tr> </tbody> </table> 					Name	minOccurs	maxOccurs	Content	ElectronicAddressText (Item 22)	1	1	Simple	ElectronicAddressTypeCode (Code E)	1	1	Simple	Name	minOccurs	maxOccurs	Content	ElectronicAddressText (Item 22a)	1	1	Simple
Name	minOccurs	maxOccurs	Content																						
ElectronicAddressText (Item 22)	1	1	Simple																						
ElectronicAddressTypeCode (Code E)	1	1	Simple																						
Name	minOccurs	maxOccurs	Content																						
ElectronicAddressText (Item 22a)	1	1	Simple																						

Element Name:	ElectronicAddress	minOccurs:	0	maxOccurs:	198						
	ElectronicAddressTypeCode (Code U)		1	1	Simple						
	*If the <ElectronicAddress> element is recorded for the Subject's (33) website URL address, then the above elements should be recorded with a valid value for each.										
Attribute(s)	The following attributes must be recorded for this element:										
	<table border="1"> <thead> <tr> <th>Name</th> <th>Description</th> </tr> </thead> <tbody> <tr> <td>SeqNum</td> <td>The value recorded for this attribute must be numeric and unique. It may contain any numeric value up to 19 characters in length.</td> </tr> </tbody> </table>					Name	Description	SeqNum	The value recorded for this attribute must be numeric and unique. It may contain any numeric value up to 19 characters in length.		
Name	Description										
SeqNum	The value recorded for this attribute must be numeric and unique. It may contain any numeric value up to 19 characters in length.										
Parent Element:	Party										
Element Restriction(s):	Record this element for the Subject (33) party type when the e-mail address and/or website URL address is known; otherwise, do not record this element.										
	The following table describes the minimum and maximum reporting requirements for this element:										
	<table border="1"> <thead> <tr> <th>Party type</th> <th>E-mail (min-max)</th> <th>URL (min-max)</th> </tr> </thead> <tbody> <tr> <td>Subject</td> <td>0-99</td> <td>0-99</td> </tr> </tbody> </table>					Party type	E-mail (min-max)	URL (min-max)	Subject	0-99	0-99
Party type	E-mail (min-max)	URL (min-max)									
Subject	0-99	0-99									
Value Restriction(s):	n/a										
Remarks:	The batch submission will be <u>rejected</u> if any of the following conditions are true: <ul style="list-style-type: none"> The element is recorded for a party type that is not applicable to this data (see Element Restrictions for more information). The element is missing a "SeqNum" attribute. The element contains a "SeqNum" attribute with a duplicate or invalid value. 										
Example:	<pre><fc2:ElectronicAddress SeqNum="74"> <fc2:ElectronicAddressText>will.mann@gmail.com</fc2:ElectronicAddressText> <fc2:ElectronicAddressTypeCode>E</fc2:ElectronicAddressTypeCode> </fc2:ElectronicAddress> <fc2:ElectronicAddress SeqNum="75"> <fc2:ElectronicAddressText>https://www.will_mann.org/</fc2:ElectronicAddressText> <fc2:ElectronicAddressTypeCode>U</fc2:ElectronicAddressTypeCode> </fc2:ElectronicAddress></pre>										

Element Name:	ElectronicAddressText	minOccurs:	1	maxOccurs:	1
Description:	Electronic address (text). This element identifies the subject's email address or website URL (Uniform Resource Locator) address. This element corresponds with the following item(s): <ul style="list-style-type: none"> Subject <ul style="list-style-type: none"> 22. E-mail address (if available) 22a. Website (URL) address (if available) <i>Please refer to Attachment C for additional information regarding the above item(s).</i>				
Attribute(s)	n/a				
Parent Element:	ElectronicAddress				
Element Restriction(s):	Record this element when the parent element is recorded.				
Value Restriction(s):	The value provided must adhere to the following requirements: <ul style="list-style-type: none"> E-mail address: 50 characters or less; the value must contain the "@" sign followed by at least one period (e.g. richardroephd@college.edu) Website (URL) address: 517 characters or less; the values should contain at least one period. 				
Remarks:	The batch submission will be <u>accepted with warning</u> if any of the following conditions are true: <ul style="list-style-type: none"> The value recorded for the element is not a valid email address or URL format. 				

Element Name:	ElectronicAddressText	minOccurs:	1	maxOccurs:	1
Example:	<pre><fc2:ElectronicAddress SeqNum="74"> <fc2:ElectronicAddressText>richardroephd@college.edu</fc2:ElectronicAddressText> <fc2:ElectronicAddressTypeCode>E</fc2:ElectronicAddressTypeCode> </fc2:ElectronicAddress> <fc2:ElectronicAddress SeqNum="75"> <fc2:ElectronicAddressText>https://www.will_mann.org/</fc2:ElectronicAddressText> <fc2:ElectronicAddressTypeCode>U</fc2:ElectronicAddressTypeCode> </fc2:ElectronicAddress></pre>				

Element Name:	ElectronicAddressTypeCode	minOccurs:	1	maxOccurs:	1						
Description:	<p>Electronic address type (code). This element identifies the type of electronic address recorded for the subject; specifically whether it is an email address or a website URL (Uniform Resource Locator) address. This element corresponds with the following item(s):</p> <ul style="list-style-type: none"> • Subject <ul style="list-style-type: none"> ○ 22. E-mail address type ○ 22a. Website (URL) type <p><i>Please refer to Attachment C for additional information regarding the above item(s).</i></p>										
Attribute(s)	n/a										
Parent Element:	ElectronicAddress										
Element Restriction(s):	Record this element when the parent element is recorded.										
Value Restriction(s):	<p>The value provided must adhere to the following requirements: Identify the electronic address type by recording the appropriate code from the list below:</p> <table border="1" style="margin-left: 20px;"> <thead> <tr> <th>Code</th> <th>Description</th> </tr> </thead> <tbody> <tr> <td>E</td> <td>E-mail address</td> </tr> <tr> <td>U</td> <td>Website (URL) address</td> </tr> </tbody> </table>					Code	Description	E	E-mail address	U	Website (URL) address
Code	Description										
E	E-mail address										
U	Website (URL) address										
Remarks:	<p>The batch submission will be <u>rejected</u> if any of the following conditions are true:</p> <ul style="list-style-type: none"> • The element is not recorded or does not contain a value (i.e. the value is null). • The value recorded is an invalid code. 										
Example:	<pre><fc2:ElectronicAddress SeqNum="74"> <fc2:ElectronicAddressText>richardroephd@college.edu</fc2:ElectronicAddressText> <fc2:ElectronicAddressTypeCode>E</fc2:ElectronicAddressTypeCode> </fc2:ElectronicAddress> <fc2:ElectronicAddress SeqNum="75"> <fc2:ElectronicAddressText>https://www.will_mann.org/</fc2:ElectronicAddressText> <fc2:ElectronicAddressTypeCode>U</fc2:ElectronicAddressTypeCode> </fc2:ElectronicAddress></pre>										

4.6.8. PartyAssociation Elements

Element Name:	PartyAssociation	minOccurs:	0	maxOccurs:	99
Description:	<p>Party association (header). This is the container for information about the subject's relationship to the institution recorded in the FinCEN SAR.</p> <p>The following tables describe all possible sub-elements for each activity level party type:</p> <div style="background-color: #e1f5fe; padding: 10px; text-align: center;"> <p>Activity party type code definitions 33 = Subject 34 = Financial institution where activity occurred</p> </div>				

Element Name:	PartyAssociation	minOccurs:	0	maxOccurs:	99																																																																																								
	<p>1. Subject: Relationship of subject to an institution recorded in Part III or IV (FinCEN SAR Part I, Items 24-26)</p> <table border="1"> <thead> <tr> <th>Name</th> <th>minOccurs</th> <th>maxOccurs</th> <th>Content</th> </tr> </thead> <tbody> <tr><td>AccountantIndicator (Item 24b)</td><td>0</td><td>1</td><td>Simple</td></tr> <tr><td>ActionTakenDateText (Item 26)</td><td>0</td><td>1</td><td>Simple</td></tr> <tr><td>AgentIndicator (Item 24c)</td><td>0</td><td>1</td><td>Simple</td></tr> <tr><td>AppraiserIndicator (Item 24d)</td><td>0</td><td>1</td><td>Simple</td></tr> <tr><td>AttorneyIndicator (Item 24e)</td><td>0</td><td>1</td><td>Simple</td></tr> <tr><td>BorrowerIndicator (Item 24f)</td><td>0</td><td>1</td><td>Simple</td></tr> <tr><td>CustomerIndicator (Item 24g)</td><td>0</td><td>1</td><td>Simple</td></tr> <tr><td>DirectorIndicator (Item 24h)</td><td>0</td><td>1</td><td>Simple</td></tr> <tr><td>EmployeeIndicator (Item 24i)</td><td>0</td><td>1</td><td>Simple</td></tr> <tr><td>NoRelationshipToInstitutionIndicator (Item 24j)</td><td>0</td><td>1</td><td>Simple</td></tr> <tr><td>OfficerIndicator (Item 24k)</td><td>0</td><td>1</td><td>Simple</td></tr> <tr><td>OtherPartyAssociationTypeText (Item 24z)</td><td>0</td><td>1</td><td>Simple</td></tr> <tr><td>OtherRelationshipIndicator (Item 24z)</td><td>0</td><td>1</td><td>Simple</td></tr> <tr><td>OwnerShareholderIndicator (Item 24l)</td><td>0</td><td>1</td><td>Simple</td></tr> <tr><td>RelationshipContinuesIndicator (Item 25a)</td><td>0</td><td>1</td><td>Simple</td></tr> <tr><td>ResignedIndicator (Item 25d)</td><td>0</td><td>1</td><td>Simple</td></tr> <tr><td>SubjectRelationshipFinancialInstitutionTINText (Item 24a)</td><td>0</td><td>1</td><td>Simple</td></tr> <tr><td>SuspendedBarredIndicator (Item 24c)</td><td>0</td><td>1</td><td>Simple</td></tr> <tr><td>TerminatedIndicator (Item 25b)</td><td>0</td><td>1</td><td>Simple</td></tr> </tbody> </table> <p><i>*If the <PartyAssociation> element is recorded for the Subject (33), then at least one of the above relationship indicator elements should be recorded with a valid value.</i></p> <p>2. Financial institution where activity occurred: Branch location (FinCEN SAR Part III, Items 68, 69, 70-74)</p> <table border="1"> <thead> <tr> <th>Name</th> <th>minOccurs</th> <th>maxOccurs</th> <th>Content</th> </tr> </thead> <tbody> <tr> <td>Party (Items 68, 69, 70-74)</td> <td>0</td> <td>99</td> <td>Complex</td> </tr> </tbody> </table>					Name	minOccurs	maxOccurs	Content	AccountantIndicator (Item 24b)	0	1	Simple	ActionTakenDateText (Item 26)	0	1	Simple	AgentIndicator (Item 24c)	0	1	Simple	AppraiserIndicator (Item 24d)	0	1	Simple	AttorneyIndicator (Item 24e)	0	1	Simple	BorrowerIndicator (Item 24f)	0	1	Simple	CustomerIndicator (Item 24g)	0	1	Simple	DirectorIndicator (Item 24h)	0	1	Simple	EmployeeIndicator (Item 24i)	0	1	Simple	NoRelationshipToInstitutionIndicator (Item 24j)	0	1	Simple	OfficerIndicator (Item 24k)	0	1	Simple	OtherPartyAssociationTypeText (Item 24z)	0	1	Simple	OtherRelationshipIndicator (Item 24z)	0	1	Simple	OwnerShareholderIndicator (Item 24l)	0	1	Simple	RelationshipContinuesIndicator (Item 25a)	0	1	Simple	ResignedIndicator (Item 25d)	0	1	Simple	SubjectRelationshipFinancialInstitutionTINText (Item 24a)	0	1	Simple	SuspendedBarredIndicator (Item 24c)	0	1	Simple	TerminatedIndicator (Item 25b)	0	1	Simple	Name	minOccurs	maxOccurs	Content	Party (Items 68, 69, 70-74)	0	99	Complex
Name	minOccurs	maxOccurs	Content																																																																																										
AccountantIndicator (Item 24b)	0	1	Simple																																																																																										
ActionTakenDateText (Item 26)	0	1	Simple																																																																																										
AgentIndicator (Item 24c)	0	1	Simple																																																																																										
AppraiserIndicator (Item 24d)	0	1	Simple																																																																																										
AttorneyIndicator (Item 24e)	0	1	Simple																																																																																										
BorrowerIndicator (Item 24f)	0	1	Simple																																																																																										
CustomerIndicator (Item 24g)	0	1	Simple																																																																																										
DirectorIndicator (Item 24h)	0	1	Simple																																																																																										
EmployeeIndicator (Item 24i)	0	1	Simple																																																																																										
NoRelationshipToInstitutionIndicator (Item 24j)	0	1	Simple																																																																																										
OfficerIndicator (Item 24k)	0	1	Simple																																																																																										
OtherPartyAssociationTypeText (Item 24z)	0	1	Simple																																																																																										
OtherRelationshipIndicator (Item 24z)	0	1	Simple																																																																																										
OwnerShareholderIndicator (Item 24l)	0	1	Simple																																																																																										
RelationshipContinuesIndicator (Item 25a)	0	1	Simple																																																																																										
ResignedIndicator (Item 25d)	0	1	Simple																																																																																										
SubjectRelationshipFinancialInstitutionTINText (Item 24a)	0	1	Simple																																																																																										
SuspendedBarredIndicator (Item 24c)	0	1	Simple																																																																																										
TerminatedIndicator (Item 25b)	0	1	Simple																																																																																										
Name	minOccurs	maxOccurs	Content																																																																																										
Party (Items 68, 69, 70-74)	0	99	Complex																																																																																										
Attribute(s)	<p>The following attributes must be recorded for this element:</p> <table border="1"> <thead> <tr> <th>Name</th> <th>Description</th> </tr> </thead> <tbody> <tr> <td>SeqNum</td> <td>The value recorded for this attribute must be numeric and unique. It may contain any numeric value up to 19 characters in length.</td> </tr> </tbody> </table>					Name	Description	SeqNum	The value recorded for this attribute must be numeric and unique. It may contain any numeric value up to 19 characters in length.																																																																																				
Name	Description																																																																																												
SeqNum	The value recorded for this attribute must be numeric and unique. It may contain any numeric value up to 19 characters in length.																																																																																												
Parent Element:	Party																																																																																												
Element Restriction(s):	<p>Record this element for the Subject (33) party type in order to describe the relationship of the subject to the filing institution and/or the financial institution(s) where activity occurred; otherwise, do not record this element. If the subject has no relationship with any of the above institutions, record a single <PartyAssociation> element for the subject where the element <NoRelationshipToInstitutionIndicator> is recorded with a "Y" value and the TIN of the filing institution is recorded for the <SubjectRelationshipFinancialInstitutionTINText> element. The <NoRelationshipToInstitutionIndicator> element should not be recorded for the subject if a relationship exists with any institution recorded in Part III or IV, even when there is no relationship with other institutions.</p>																																																																																												
Value Restriction(s):	n/a																																																																																												

Element Name:	PartyAssociation	minOccurs:	0	maxOccurs:	99
Remarks:	<p>The batch submission will be <u>rejected</u> if any of the following conditions are true:</p> <ul style="list-style-type: none"> The element is recorded for a party type that is not applicable to this data (see Element Restrictions for more information). The element is missing a "SeqNum" attribute. The element contains a "SeqNum" attribute with a duplicate or invalid value. <p>The batch submission will be accepted with warning if any of the following conditions are true:</p> <ul style="list-style-type: none"> The element is recorded but at least one indicator identifying the type of relationship is not recorded with a "Y" value. . 				
Example:	<pre><fc2:PartyAssociation SeqNum="77"> <fc2:AccountantIndicator>Y</fc2:AccountantIndicator> <fc2:ActionTakenDateText>20170905</fc2:ActionTakenDateText> <fc2:ResignedIndicator>Y</fc2:ResignedIndicator> <fc2:SubjectRelationshipFinancialInstitutionTINText>458789856</fc2:SubjectRelationshipFinancialInstitutionTINText> </fc2:PartyAssociation></pre>				

Element Name:	AccountantIndicator	minOccurs:	0	maxOccurs:	1
Description:	<p>Accountant (indicator). This element declares that the subject's relationship to the institution can be described as "Accountant." This element corresponds with the following item(s):</p> <ul style="list-style-type: none"> 24b. Relationship of subject to institution: Accountant <p><i>Please refer to Attachment C for additional information regarding the above item(s).</i></p>				
Attribute(s)	n/a				
Parent Element:	PartyAssociation				
Element Restriction(s):	Record this element when it describes the relationship of the subject (33) to the institution TIN recorded in the <SubjectRelationshipFinancialInstitutionTINText> element; otherwise, do not record this element.				
Value Restriction(s):	The value provided must adhere to the following requirements: "Y" (to indicate Accountant)				
Remarks:	<p>The batch submission will be <u>rejected</u> if any of the following conditions are true:</p> <ul style="list-style-type: none"> The element is recorded for a party type that is not applicable to this data (see Element Restrictions for more information). The value recorded is not equal to "Y" or not equal to null. 				
Example:	<fc2:AccountantIndicator>Y</fc2:AccountantIndicator>				

Element Name:	ActionTakenDateText	minOccurs:	0	maxOccurs:	1
Description:	<p>Action date (date). This element identifies the date on which the action was taken in the event that the relationship no longer continues between the subject and the institution. This element corresponds with the following item(s):</p> <ul style="list-style-type: none"> 26. Relationship of subject to institution: Action date <p><i>Please refer to Attachment C for additional information regarding the above item(s).</i></p>				
Attribute(s)	n/a				
Parent Element:	PartyAssociation				
Element Restriction(s):	Record this element when the party type is associated with the Subject (33) and the status of the subject relationship to the institution TIN recorded for the <SubjectRelationshipFinancialInstitutionTINText> element has been identified as Terminated, Suspended/barred, or Resigned; otherwise, do not record this element.				
Value Restriction(s):	The value provided must adhere to the following requirements: 8 numeric characters in the format YYYYMMDD where YYYY = year, MM = month, and DD = day. Single digit days or months must be prefaced by a zero.				
Remarks:	The batch submission will be <u>rejected</u> if any of the following conditions are true:				

Element Name:	ActionTakenDateText	minOccurs:	0	maxOccurs:	1
	<ul style="list-style-type: none"> The element is recorded for a party type that is not applicable to this data (see Element Restrictions for more information). <p>The batch submission will be <u>accepted with warning</u> if any of the following conditions are true:</p> <ul style="list-style-type: none"> The element is not recorded or does not contain a value and the status of the relationship is Terminated, Suspended/barred, or Resigned. The element is recorded with a valid value but the status of the relationship is not equal to Terminated, Suspended/barred, or Resigned. The value recorded for the element is not in the required format (YYYYMMDD). 				
Example:	<fc2:ActionTakenDateText>20170905</fc2:ActionTakenDateText>				

Element Name:	AgentIndicator	minOccurs:	0	maxOccurs:	1
Description:	<p>Agent (indicator). This element declares that the subject's relationship to the institution can be described as "Agent." This element corresponds with the following item(s):</p> <ul style="list-style-type: none"> 24c. Relationship of subject to institution: Agent <p><i>Please refer to Attachment C for additional information regarding the above item(s).</i></p>				
Attribute(s)	n/a				
Parent Element:	PartyAssociation				
Element Restriction(s):	Record this element when it describes the relationship of the subject (33) to the institution TIN recorded in the <SubjectRelationshipFinancialInstitutionTINText> element; otherwise, do not record this element.				
Value Restriction(s):	The value provided must adhere to the following requirements: "Y" (to indicate Agent)				
Remarks:	<p>The batch submission will be <u>rejected</u> if any of the following conditions are true:</p> <ul style="list-style-type: none"> The element is recorded for a party type that is not applicable to this data (see Element Restrictions for more information). The value recorded is not equal to "Y" or not equal to null. 				
Example:	<fc2:AgentIndicator>Y</fc2:AgentIndicator>				

Element Name:	AppraiserIndicator	minOccurs:	0	maxOccurs:	1
Description:	<p>Appraiser (indicator). This element declares that the subject's relationship to the institution can be described as "Appraiser." This element corresponds with the following item(s):</p> <ul style="list-style-type: none"> 24d. Relationship of subject to institution: Appraiser <p><i>Please refer to Attachment C for additional information regarding the above item(s).</i></p>				
Attribute(s)	n/a				
Parent Element:	PartyAssociation				
Element Restriction(s):	Record this element when it describes the relationship of the subject (33) to the institution TIN recorded in the <SubjectRelationshipFinancialInstitutionTINText> element; otherwise, do not record this element.				
Value Restriction(s):	The value provided must adhere to the following requirements: "Y" (to indicate Appraiser)				
Remarks:	<p>The batch submission will be <u>rejected</u> if any of the following conditions are true:</p> <ul style="list-style-type: none"> The element is recorded for a party type that is not applicable to this data (see Element Restrictions for more information). The value recorded is not equal to "Y" or not equal to null. 				
Example:	<fc2:AppraiserIndicator>Y</fc2:AppraiserIndicator>				

Element Name:	AttorneyIndicator	minOccurs:	0	maxOccurs:	1
Description:	<p>Attorney (indicator). This element declares that the subject's relationship to the institution can be described as "Attorney." This element corresponds with the following item(s):</p>				

Element Name:	AttorneyIndicator	minOccurs:	0	maxOccurs:	1
	<ul style="list-style-type: none"> 24e. Relationship of subject to institution: Attorney <i>Please refer to Attachment C for additional information regarding the above item(s).</i>				
Attribute(s)	n/a				
Parent Element:	PartyAssociation				
Element Restriction(s):	Record this element when it describes the relationship of the subject (33) to the institution TIN recorded in the <SubjectRelationshipFinancialInstitutionTINText> element; otherwise, do not record this element.				
Value Restriction(s):	The value provided must adhere to the following requirements: "Y" (to indicate Attorney)				
Remarks:	The batch submission will be <u>rejected</u> if any of the following conditions are true: <ul style="list-style-type: none"> The element is recorded for a party type that is not applicable to this data (see Element Restrictions for more information). The value recorded is not equal to "Y" or not equal to null. 				
Example:	<fc2:AttorneyIndicator>Y</fc2:AttorneyIndicator>				

Element Name:	BorrowerIndicator	minOccurs:	0	maxOccurs:	1
Description:	Borrower (indicator). This element declares that the subject's relationship to the institution can be described as "Borrower." This element corresponds with the following item(s): <ul style="list-style-type: none"> 24f. Relationship of subject to institution: Borrower <i>Please refer to Attachment C for additional information regarding the above item(s).</i>				
Attribute(s)	n/a				
Parent Element:	PartyAssociation				
Element Restriction(s):	Record this element when it describes the relationship of the subject (33) to the institution TIN recorded in the <SubjectRelationshipFinancialInstitutionTINText> element; otherwise, do not record this element.				
Value Restriction(s):	The value provided must adhere to the following requirements: "Y" (to indicate Borrower)				
Remarks:	The batch submission will be <u>rejected</u> if any of the following conditions are true: <ul style="list-style-type: none"> The element is recorded for a party type that is not applicable to this data (see Element Restrictions for more information). The value recorded is not equal to "Y" or not equal to null. 				
Example:	<fc2:BorrowerIndicator>Y</fc2:BorrowerIndicator>				

Element Name:	CustomerIndicator	minOccurs:	0	maxOccurs:	1
Description:	Customer (indicator). This element declares that the subject's relationship to the institution can be described as "Customer." This element corresponds with the following item(s): <ul style="list-style-type: none"> 24g. Relationship of subject to institution: Customer <i>Please refer to Attachment C for additional information regarding the above item(s).</i>				
Attribute(s)	n/a				
Parent Element:	PartyAssociation				
Element Restriction(s):	Record this element when it describes the relationship of the subject (33) to the institution TIN recorded in the <SubjectRelationshipFinancialInstitutionTINText> element; otherwise, do not record this element.				
Value Restriction(s):	The value provided must adhere to the following requirements: "Y" (to indicate Customer)				
Remarks:	The batch submission will be <u>rejected</u> if any of the following conditions are true: <ul style="list-style-type: none"> The element is recorded for a party type that is not applicable to this data (see Element Restrictions for more information). The value recorded is not equal to "Y" or not equal to null. 				
Example:	<fc2:CustomerIndicator>Y</fc2:CustomerIndicator>				

Element Name:	DirectorIndicator	minOccurs:	0	maxOccurs:	1
Description:	<p>Director (indicator). This element declares that the subject's relationship to the institution can be described as "Director." This element corresponds with the following item(s):</p> <ul style="list-style-type: none"> 24h. Relationship of subject to institution: Director <p><i>Please refer to Attachment C for additional information regarding the above item(s).</i></p>				
Attribute(s)	n/a				
Parent Element:	PartyAssociation				
Element Restriction(s):	Record this element when it describes the relationship of the subject (33) to the institution TIN recorded in the <SubjectRelationshipFinancialInstitutionTINText> element; otherwise, do not record this element.				
Value Restriction(s):	The value provided must adhere to the following requirements: "Y" (to indicate Director)				
Remarks:	<p>The batch submission will be <u>rejected</u> if any of the following conditions are true:</p> <ul style="list-style-type: none"> The element is recorded for a party type that is not applicable to this data (see Element Restrictions for more information). The value recorded is not equal to "Y" or not equal to null. <p>The batch submission will be <u>accepted with warning</u> if any of the following conditions are true:</p> <ul style="list-style-type: none"> The element is recorded with a "Y" value for the subject and <JointReportIndicator> contains a "Y" value. 				
Example:	<fc2:DirectorIndicator>Y</fc2:DirectorIndicator>				

Element Name:	EmployeeIndicator	minOccurs:	0	maxOccurs:	1
Description:	<p>Employee (indicator). This element declares that the subject's relationship to the institution can be described as "Employee." This element corresponds with the following item(s):</p> <ul style="list-style-type: none"> 24i. Relationship of subject to institution: Employee <p><i>Please refer to Attachment C for additional information regarding the above item(s).</i></p>				
Attribute(s)	n/a				
Parent Element:	PartyAssociation				
Element Restriction(s):	Record this element when it describes the relationship of the subject (33) to the institution TIN recorded in the <SubjectRelationshipFinancialInstitutionTINText> element; otherwise, do not record this element.				
Value Restriction(s):	The value provided must adhere to the following requirements: "Y" (to indicate Employee)				
Remarks:	<p>The batch submission will be <u>rejected</u> if any of the following conditions are true:</p> <ul style="list-style-type: none"> The element is recorded for a party type that is not applicable to this data (see Element Restrictions for more information). The value recorded is not equal to "Y" or not equal to null. <p>The batch submission will be <u>accepted with warning</u> if any of the following conditions are true:</p> <ul style="list-style-type: none"> The element is recorded with a "Y" value for the subject and <JointReportIndicator> contains a "Y" value. 				
Example:	<fc2:EmployeeIndicator>Y</fc2:EmployeeIndicator>				

Element Name:	NoRelationshipToInstitutionIndicator	minOccurs:	0	maxOccurs:	1
Description:	<p>No relationship to institution (indicator). This element declares that the subject has no relationship with any of the financial institutions recorded in the FinCEN SAR. This element corresponds with the following item(s):</p> <ul style="list-style-type: none"> 24j. Relationship of subject to institution: No relationship to institution <p><i>Please refer to Attachment C for additional information regarding the above item(s).</i></p>				
Attribute(s)	n/a				
Parent Element:	PartyAssociation				

Element Name:	NoRelationshipToInstitutionIndicator	minOccurs:	0	maxOccurs:	1
Element Restriction(s):	Record this element when the party type is associated with the Subject (33) and the subject does not have a relationship with filing institution or financial institution(s) where activity occurred*; otherwise, do not record this element.				
Value Restriction(s):	The value provided must adhere to the following requirements: "Y" (to indicate "No relationship to an institution")				
Remarks:	<p>The batch submission will be <u>rejected</u> if any of the following conditions are true:</p> <ul style="list-style-type: none"> The element is recorded for a party type that is not applicable to this data (see Element Restrictions for more information). The value recorded is not equal to "Y" or not equal to null. 				
Example:	<fc2:NoRelationshipToInstitutionIndicator>Y</fc2:NoRelationshipToInstitutionIndicator>				

Element Name:	OfficerIndicator	minOccurs:	0	maxOccurs:	1
Description:	<p>Officer (indicator). This element declares that the subject's relationship to the institution can be described as "Officer." This element corresponds with the following item(s):</p> <ul style="list-style-type: none"> 24k Relationship of subject to institution: Officer <p><i>Please refer to Attachment C for additional information regarding the above item(s).</i></p>				
Attribute(s)	n/a				
Parent Element:	PartyAssociation				
Element Restriction(s):	Record this element when it describes the relationship of the subject (33) to the institution TIN recorded in the <SubjectRelationshipFinancialInstitutionTINText> element; otherwise, do not record this element.				
Value Restriction(s):	The value provided must adhere to the following requirements: "Y" (to indicate Officer)				
Remarks:	<p>The batch submission will be <u>rejected</u> if any of the following conditions are true:</p> <ul style="list-style-type: none"> The element is recorded for a party type that is not applicable to this data (see Element Restrictions for more information). The value recorded is not equal to "Y" or not equal to null. <p>The batch submission will be <u>accepted with warning</u> if any of the following conditions are true:</p> <ul style="list-style-type: none"> The element is recorded with a "Y" value for the subject and <JointReportIndicator> contains a "Y" value. 				
Example:	<fc2:OfficerIndicator>Y</fc2:OfficerIndicator>				

Element Name:	OtherPartyAssociationTypeText	minOccurs:	0	maxOccurs:	1
Description:	<p>Other relationship (description). This element declares that the subject's relationship to the institution is not covered by any of pre-defined options. This element corresponds with the following item(s):</p> <ul style="list-style-type: none"> 24z. Relationship of subject to institution: Other (description) <p><i>Please refer to Attachment C for additional information regarding the above item(s).</i></p>				
Attribute(s)	n/a				
Parent Element:	PartyAssociation				
Element Restriction(s):	Record this element when the party type is associated with the Subject (33) and the <OtherRelationshipIndicator> element contains a "Y" value; otherwise, do not record this element.				
Value Restriction(s):	The value provided must adhere to the following requirements: 50 characters or less.				
Remarks:	<p>The batch submission will be <u>rejected</u> if any of the following conditions are true:</p> <ul style="list-style-type: none"> The element is recorded for a party type that is not applicable to this data (see Element Restrictions for more information). <p>The batch submission will be <u>accepted with warning</u> if any of the following conditions are true:</p> <ul style="list-style-type: none"> The element is not recorded or does not contain a value and Other is indicated. The element is recorded with a value and Other is not indicated. 				
Example:	<fc2:OtherPartyAssociationTypeText>Other description</fc2:OtherPartyAssociationTypeText>				

Element Name:	OtherRelationshipIndicator	minOccurs:	0	maxOccurs:	1
Description:	<p>Other relationship (indicator). This element describes the other type of relationship between the subject and the institution. This element corresponds with the following item(s):</p> <ul style="list-style-type: none"> 24z. Relationship of subject to institution: Other (indicator) <p><i>Please refer to Attachment C for additional information regarding the above item(s).</i></p>				
Attribute(s)	n/a				
Parent Element:	PartyAssociation				
Element Restriction(s):	Record this element when it describes the relationship of the subject (33) to the institution TIN recorded in the <SubjectRelationshipFinancialInstitutionTINText> element cannot be categorized by one of the pre-defined indicator elements; otherwise, do not record this element. If this element is recorded with a "Y" value, please ensure a brief description of the relationship type is recorded in the <OtherPartyAssociationTypeText> element.				
Value Restriction(s):	The value provided must adhere to the following requirements: "Y" (to indicate "Other relationship")				
Remarks:	<p>The batch submission will be <u>rejected</u> if any of the following conditions are true:</p> <ul style="list-style-type: none"> The element is recorded for a party type that is not applicable to this data (see Element Restrictions for more information). The value recorded is not equal to "Y" or not equal to null. 				
Example:	<fc2:OtherRelationshipIndicator>Y</fc2:OtherRelationshipIndicator>				

Element Name:	OwnerShareholderIndicator	minOccurs:	0	maxOccurs:	1
Description:	<p>Owner or controlling shareholder (indicator). This element declares that the subject's relationship to the institution can be described as "Owner or controlling shareholder." This element corresponds with the following item(s):</p> <ul style="list-style-type: none"> 24l. Relationship of subject to institution: Owner or Controlling Shareholder <p><i>Please refer to Attachment C for additional information regarding the above item(s).</i></p>				
Attribute(s)	n/a				
Parent Element:	PartyAssociation				
Element Restriction(s):	Record this element when it describes the relationship of the subject (33) to the institution TIN recorded in the <SubjectRelationshipFinancialInstitutionTINText> element; otherwise, do not record this element.				
Value Restriction(s):	The value provided must adhere to the following requirements: "Y" (to indicate "Owner or controlling shareholder")				
Remarks:	<p>The batch submission will be <u>rejected</u> if any of the following conditions are true:</p> <ul style="list-style-type: none"> The element is recorded for a party type that is not applicable to this data (see Element Restrictions for more information). The value recorded is not equal to "Y" or not equal to null. <p>The batch submission will be <u>accepted with warning</u> if any of the following conditions are true:</p> <ul style="list-style-type: none"> The element is recorded with a "Y" value for the subject and <JointReportIndicator> contains a "Y" value. 				
Example:	<fc2:OwnerShareholderIndicator>Y</fc2:OwnerShareholderIndicator>				

Element Name:	RelationshipContinuesIndicator	minOccurs:	0	maxOccurs:	1
Description:	<p>Relationship continues (indicator). This element declares that the status of the subject's relationship to the institution can be described as "Relationship continues." This element corresponds with the following item(s):</p> <ul style="list-style-type: none"> 25a. Relationship status of subject to institution: Relationship continues <p><i>Please refer to Attachment C for additional information regarding the above item(s).</i></p>				

Element Name:	RelationshipContinuesIndicator	minOccurs:	0	maxOccurs:	1
Attribute(s)	n/a				
Parent Element:	PartyAssociation				
Element Restriction(s):	Record this element for the Subject (33) party type when it best describes the status of the relationship when the subject's relationship to the institution TIN recorded for the <SubjectRelationshipFinancialInstitutionTINText> element has been identified as Director, Employee, Officer, or Owner/Controlling Shareholder; otherwise, do not record this element.				
Value Restriction(s):	The value provided must adhere to the following requirements: "Y" (to indicate "Relationship continues")				
Remarks:	<p>The batch submission will be <u>rejected</u> if any of the following conditions are true:</p> <ul style="list-style-type: none"> The element is recorded for a party type that is not applicable to this data (see Element Restrictions for more information). The value recorded is not equal to "Y" or not equal to null. <p>The batch submission will be accepted with warning if any of the following conditions are true:</p> <ul style="list-style-type: none"> The element is recorded with a valid value but the type of relationship is not equal to Director, Employee, Officer, or Owner/Controlling Shareholder. The element is not recorded or does not contain a value and the type of relationship is equal to Director, Employee, Officer, and/or Owner/Controlling Shareholder. 				
Example:	<fc2:RelationshipContinuesIndicator>Y</fc2:RelationshipContinuesIndicator>				

Element Name:	ResignedIndicator	minOccurs:	0	maxOccurs:	1
Description:	<p>Resigned (indicator). This element declares that the status of the subject's relationship to the institution can be described as "Resigned." This element corresponds with the following item(s):</p> <ul style="list-style-type: none"> 25d. Relationship status of subject to institution: Resigned <p><i>Please refer to Attachment C for additional information regarding the above item(s).</i></p>				
Attribute(s)	n/a				
Parent Element:	PartyAssociation				
Element Restriction(s):	Record this element for the Subject (33) party type when it best describes the status of the relationship when the subject's relationship to the institution TIN recorded for the <SubjectRelationshipFinancialInstitutionTINText> element has been identified as Director, Employee, Officer, or Owner/Controlling Shareholder; otherwise, do not record this element.				
Value Restriction(s):	The value provided must adhere to the following requirements: "Y" (to indicate Resigned)				
Remarks:	<p>The batch submission will be <u>rejected</u> if any of the following conditions are true:</p> <ul style="list-style-type: none"> The element is recorded for a party type that is not applicable to this data (see Element Restrictions for more information). The value recorded is not equal to "Y" or not equal to null. <p>The batch submission will be accepted with warning if any of the following conditions are true:</p> <ul style="list-style-type: none"> The element is recorded with a valid value but the type of relationship is not equal to Director, Employee, Officer, or Owner/Controlling Shareholder. The element is not recorded or does not contain a value and the type of relationship is equal to Director, Employee, Officer, and/or Owner/Controlling Shareholder. 				
Example:	<fc2:ResignedIndicator>Y</fc2:ResignedIndicator>				

Element Name:	SubjectRelationshipFinancialInstitutionTINText	minOccurs:	0	maxOccurs:	1
Description:	<p>Institution TIN (text). This element identifies the TIN of the institution recorded in the FinCEN SAR that the subject has a relationship with. This element corresponds with the following item(s):</p> <ul style="list-style-type: none"> 24a. Relationship of subject to institution: Institution TIN <p><i>Please refer to Attachment C for additional information regarding the above item(s).</i></p>				
Attribute(s)	n/a				

Element Name:	SubjectRelationshipFinancialInstitutionTINText	minOccurs:	0	maxOccurs:	1
Parent Element:	PartyAssociation				
Element Restriction(s):	Record this element for the Subject (33) party type in order to identify the TIN (if known) associated with the filing institution or financial institution where activity occurred in which the subject has a relationship with; otherwise, do not record this element. If the subject has no relationship with any of these institutions, record the TIN of the filing institution for this element and record a "Y" value for the <NoRelationshipToInstitutionIndicator> element.				
Value Restriction(s):	The value provided must adhere to the following requirements: 25 characters or less. The number recorded must match the TIN recorded for the filing institution or the financial institution where activity occurred.				
Remarks:	<p>The batch submission will be <u>rejected</u> if any of the following conditions are true:</p> <ul style="list-style-type: none"> The element is recorded for a party type that is not applicable to this data (see Element Restrictions for more information). The value recorded does not match the TIN for the Filing institution or the Financial institution where the activity occurred. 				
Example:	<fc2:SubjectRelationshipFinancialInstitutionTINText>458789856</fc2:SubjectRelationshipFinancialInstitutionTINText>				

Element Name:	SuspendedBarredIndicator	minOccurs:	0	maxOccurs:	1
Description:	<p>Suspended/Barred (indicator). This element declares that the status of the subject's relationship to the institution can be described as "Suspended/Barred." This element corresponds with the following item(s):</p> <ul style="list-style-type: none"> 25c. Relationship status of subject to institution: Suspended/barred <p><i>Please refer to Attachment C for additional information regarding the above item(s).</i></p>				
Attribute(s)	n/a				
Parent Element:	PartyAssociation				
Element Restriction(s):	Record this element for the Subject (33) party type when it best describes the status of the relationship when the subject's relationship to the institution TIN recorded for the <SubjectRelationshipFinancialInstitutionTINText> element has been identified as Director, Employee, Officer, or Owner/Controlling Shareholder; otherwise, do not record this element.				
Value Restriction(s):	The value provided must adhere to the following requirements: "Y" (to indicate Suspended/Barred)				
Remarks:	<p>The batch submission will be <u>rejected</u> if any of the following conditions are true:</p> <ul style="list-style-type: none"> The element is recorded for a party type that is not applicable to this data (see Element Restrictions for more information). The value recorded is not equal to "Y" or not equal to null. <p>The batch submission will be accepted with warning if any of the following conditions are true:</p> <ul style="list-style-type: none"> The element is recorded with a valid value but the type of relationship is not equal to Director, Employee, Officer, or Owner/Controlling Shareholder. The element is not recorded or does not contain a value and the type of relationship is equal to Director, Employee, Officer, and/or Owner/Controlling Shareholder. 				
Example:	<fc2:SuspendedBarredIndicator>Y</fc2:SuspendedBarredIndicator>				

Element Name:	TerminatedIndicator	minOccurs:	0	maxOccurs:	1
Description:	<p>Terminated (indicator). This element declares that the status of the subject's relationship to the institution can be described as "Terminated." This element corresponds with the following item(s):</p> <ul style="list-style-type: none"> 25d. Relationship status of subject to institution: Terminated <p><i>Please refer to Attachment C for additional information regarding the above item(s).</i></p>				
Attribute(s)	n/a				
Parent Element:	PartyAssociation				

Element Name:	TerminatedIndicator	minOccurs:	0	maxOccurs:	1
Element Restriction(s):	Record this element for the Subject (33) party type when it best describes the status of the relationship when the subject's relationship to the institution TIN recorded for the <SubjectRelationshipFinancialInstitutionTINText> element has been identified as Director, Employee, Officer, or Owner/Controlling Shareholder; otherwise, do not record this element.				
Value Restriction(s):	The value provided must adhere to the following requirements: "Y" (to indicate Terminated)				
Remarks:	<p>The batch submission will be <u>rejected</u> if any of the following conditions are true:</p> <ul style="list-style-type: none"> The element is recorded for a party type that is not applicable to this data (see Element Restrictions for more information). The value recorded is not equal to "Y" or not equal to null. <p>The batch submission will be accepted with warning if any of the following conditions are true:</p> <ul style="list-style-type: none"> The element is recorded with a valid value but the type of relationship is not equal to Director, Employee, Officer, or Owner/Controlling Shareholder. The element is not recorded or does not contain a value and the type of relationship is equal to Director, Employee, Officer, and/or Owner/Controlling Shareholder. 				
Example:	<fc2:TerminatedIndicator>Y</fc2:TerminatedIndicator>				

Element Name:	Party	See <i>Party Elements</i> (below) for details.
---------------	-------	--

4.6.8.1. Party Elements

The following Party element (and associated sub-elements) corresponds with the Part III Branch location where activity occurred. In the event that the FinCEN SAR involves branch locations, up to 99 branch locations may be reported; otherwise, this Party element should not be recorded.

Element Name:	Party	minOccurs:	0	maxOccurs:	99																												
Description:	<p>Party (header). This is the container for information about the individual or entity associated with the FinCEN SAR; specifically, the branch location where activity occurred.</p> <p>The following tables describe all possible sub-elements for the Branch (46) party type:</p> <div style="background-color: #e1f5fe; padding: 10px; text-align: center;"> <p>Activity party type code definitions 46 = Branch location where activity occurred</p> </div> <ol style="list-style-type: none"> Financial institution where activity occurred: Branch location (FinCEN SAR Part III, Items 68, 69, 70-74) <table border="1" style="width: 100%; border-collapse: collapse;"> <thead> <tr> <th style="background-color: #e1f5fe;">Name</th> <th>minOccurs</th> <th>maxOccurs</th> <th>Content</th> </tr> </thead> <tbody> <tr> <td>ActivityPartyTypeCode (Code 46)</td> <td style="text-align: center;">1</td> <td style="text-align: center;">1</td> <td>Simple</td> </tr> <tr> <td>PayLocationIndicator (Item 68b)</td> <td style="text-align: center;">0</td> <td style="text-align: center;">1</td> <td>Simple</td> </tr> <tr> <td>SellingLocationIndicator (Item 68a)</td> <td style="text-align: center;">0</td> <td style="text-align: center;">1</td> <td>Simple</td> </tr> <tr> <td>SellingPayingLocationIndicator (Item 68c)</td> <td style="text-align: center;">0</td> <td style="text-align: center;">1</td> <td>Simple</td> </tr> <tr> <td>Address (Items 69, 71-74)</td> <td style="text-align: center;">1</td> <td style="text-align: center;">1</td> <td>Complex</td> </tr> <tr> <td>PartyIdentification (Item 70)</td> <td style="text-align: center;">0</td> <td style="text-align: center;">1</td> <td>Complex</td> </tr> </tbody> </table>					Name	minOccurs	maxOccurs	Content	ActivityPartyTypeCode (Code 46)	1	1	Simple	PayLocationIndicator (Item 68b)	0	1	Simple	SellingLocationIndicator (Item 68a)	0	1	Simple	SellingPayingLocationIndicator (Item 68c)	0	1	Simple	Address (Items 69, 71-74)	1	1	Complex	PartyIdentification (Item 70)	0	1	Complex
Name	minOccurs	maxOccurs	Content																														
ActivityPartyTypeCode (Code 46)	1	1	Simple																														
PayLocationIndicator (Item 68b)	0	1	Simple																														
SellingLocationIndicator (Item 68a)	0	1	Simple																														
SellingPayingLocationIndicator (Item 68c)	0	1	Simple																														
Address (Items 69, 71-74)	1	1	Complex																														
PartyIdentification (Item 70)	0	1	Complex																														
Attribute(s)	<p>The following attributes must be recorded for this element:</p> <table border="1" style="width: 100%; border-collapse: collapse;"> <thead> <tr> <th style="background-color: #e1f5fe;">Name</th> <th>Description</th> </tr> </thead> <tbody> <tr> <td>SeqNum</td> <td>The value recorded for this attribute must be numeric and unique. It may contain any numeric value up to 19 characters in length.</td> </tr> </tbody> </table>					Name	Description	SeqNum	The value recorded for this attribute must be numeric and unique. It may contain any numeric value up to 19 characters in length.																								
Name	Description																																
SeqNum	The value recorded for this attribute must be numeric and unique. It may contain any numeric value up to 19 characters in length.																																

Element Name:	Party	minOccurs:	0	maxOccurs:	99
Parent Element:	PartyAssociation				
Element Restriction(s):	Record this element if the associated financial institution has a branch involved in the suspicious activity; otherwise, do not record this element. A branch is a location (such as an office or ATM) owned by the financial institution but located separately from the financial institution's headquarters. Generally, a branch operates under the same TIN as the financial institution. Up to 99 branches may be recorded for a single FinCEN SAR.				
Value Restriction(s):	n/a				
Remarks:	The batch submission will be <u>rejected</u> if any of the following conditions are true: <ul style="list-style-type: none"> • The element is missing a "SeqNum" attribute. • The element contains a "SeqNum" attribute with a duplicate or invalid value. • More than 99 branches are recorded for the FinCEN SAR. 				
Example:	See Part Elements by Party Type for a detailed example...				

Element Name:	ActivityPartyTypeCode	minOccurs:	1	maxOccurs:	1				
Description:	Party type (code). This element identifies the type of party associated with the FinCEN SAR; specifically, the branch where activity occurred.								
Attribute(s)	n/a								
Parent Element:	Party								
Element Restriction(s):	Required. This element must be recorded for each <Party> element regardless of party type.								
Value Restriction(s):	The value provided must adhere to the following requirements: <table border="1" data-bbox="443 926 943 1010"> <thead> <tr> <th>Code</th> <th>Description</th> </tr> </thead> <tbody> <tr> <td>46</td> <td>Branch where activity occurred</td> </tr> </tbody> </table>					Code	Description	46	Branch where activity occurred
Code	Description								
46	Branch where activity occurred								
Remarks:	The batch submission will be <u>rejected</u> if any of the following conditions are true: <ul style="list-style-type: none"> • The element is not recorded. • The element is recorded but with no value (i.e. the value is null). • The element contains a value not equal to "46". 								
Example:	<fc2:ActivityPartyTypeCode>46</fc2:ActivityPartyTypeCode>								

Element Name:	PayLocationIndicator	minOccurs:	0	maxOccurs:	1
Description:	Paying location (indicator). This element declares that the customer received payment from the branch for the products or instruments recorded in the FinCEN SAR. This element corresponds with the following item(s): <ul style="list-style-type: none"> • 68b. Branch's role in transaction (Paying location) <i>Please refer to Attachment C for additional information regarding the above item(s).</i>				
Attribute(s)	n/a				
Parent Element:	Party				
Element Restriction(s):	Record this element when the party type is associated with the Branch Where Activity Occurred (46) and the customer received payment from the branch (46) for the recorded products or instruments; otherwise, do not record this element.				
Value Restriction(s):	The value provided must adhere to the following requirements: "Y" (to indicate "Paying location")				
Remarks:	The batch submission will be <u>rejected</u> if any of the following conditions are true: <ul style="list-style-type: none"> • The element is recorded for a party type that is not applicable to this data (see Element Restrictions for more information). • The value recorded is not equal to "Y" or not equal to null. The batch submission will be <u>accepted with warnings</u> if any of the following conditions are true: <ul style="list-style-type: none"> • More than one role is recorded for the branch's role in the transaction. 				

Element Name:	PayLocationIndicator	minOccurs:	0	maxOccurs:	1
Example:	<fc2:PayLocationIndicator>Y</fc2:PayLocationIndicator>				

Element Name:	SellingLocationIndicator	minOccurs:	0	maxOccurs:	1
Description:	Selling location (indicator). This element declares that the branch sold the products or instruments recorded in the FinCEN SAR. This element corresponds with the following item(s): <ul style="list-style-type: none"> 68a. Branch's role in transaction (Selling location) <i>Please refer to Attachment C for additional information regarding the above item(s).</i>				
Attribute(s)	n/a				
Parent Element:	Party				
Element Restriction(s):	Record this element when the party type is associated with the Branch Where Activity Occurred (46) and the branch sold the recorded products or instruments; otherwise, do not record this element.				
Value Restriction(s):	The value provided must adhere to the following requirements: "Y" (to indicate "Selling location")				
Remarks:	The batch submission will be <u>rejected</u> if any of the following conditions are true: <ul style="list-style-type: none"> The element is recorded for a party type that is not applicable to this data (see Element Restrictions for more information). The value recorded is not equal to "Y" or not equal to null. The batch submission will be <u>accepted with warnings</u> if any of the following conditions are true: <ul style="list-style-type: none"> More than one role is recorded for the branch's role in the transaction. 				
Example:	<fc2:SellingLocationIndicator>Y</fc2:SellingLocationIndicator>				

Element Name:	SellingPayingLocationIndicator	minOccurs:	0	maxOccurs:	1
Description:	Selling and Paying location (indicator). This element declares that the branch was both a paying and selling location for the products or instruments recorded in the FinCEN SAR. This element corresponds with the following item(s): <ul style="list-style-type: none"> 68c. Branch's role in transaction (both Selling and Paying location) <i>Please refer to Attachment C for additional information regarding the above item(s).</i>				
Attribute(s)	n/a				
Parent Element:	Party				
Element Restriction(s):	Record this element when the party type is associated with the Branch Where Activity Occurred (46) and the branch was both the selling and paying location for the recorded products or instruments; otherwise, do not record this element.				
Value Restriction(s):	The value provided must adhere to the following requirements: "Y" (to indicate both Selling and Paying location)				
Remarks:	The batch submission will be <u>rejected</u> if any of the following conditions are true: <ul style="list-style-type: none"> The element is recorded for a party type that is not applicable to this data (see Element Restrictions for more information). The value recorded is not equal to "Y" or not equal to null. The batch submission will be <u>accepted with warnings</u> if any of the following conditions are true: <ul style="list-style-type: none"> More than one role is recorded for the branch's role in the transaction. 				
Example:	<fc2:SellingPayingLocationIndicator>Y</fc2:SellingPayingLocationIndicator>				

Element Name:	Address	See <i>Address Elements</i> (below) for details.
---------------	---------	--

Element Name:	PartyIdentification	See <i>PartyIdentification Elements</i> (below) for details.
---------------	---------------------	--

4.6.8.1.1. Address Elements

Element Name:	Address	minOccurs:	1	maxOccurs:	99																								
Description:	<p>Address (header). This is the container for information about the address of the party; specifically, the branch where activity occurred. The following tables describe all possible sub-elements for the Branch (46) party type:</p> <p>1. Branch: Address (FinCEN SAR Part III, Items 69, 71-74)</p> <table border="1"> <thead> <tr> <th>Name</th> <th>minOccurs</th> <th>maxOccurs</th> <th>Content</th> </tr> </thead> <tbody> <tr> <td>RawCityText</td> <td>0</td> <td>1</td> <td>Simple</td> </tr> <tr> <td>RawCountryCodeText</td> <td>1</td> <td>1</td> <td>Simple</td> </tr> <tr> <td>RawStateCodeText</td> <td>0</td> <td>1</td> <td>Simple</td> </tr> <tr> <td>RawStreetAddress1Text</td> <td>0</td> <td>1</td> <td>Simple</td> </tr> <tr> <td>RawZIPCode</td> <td>0</td> <td>1</td> <td>Simple</td> </tr> </tbody> </table> <p><i>*If the <Address> element is recorded for the Branch (46) party type, then the <RawCountryCodeText> must contain a value in addition to any other known address elements.</i></p>					Name	minOccurs	maxOccurs	Content	RawCityText	0	1	Simple	RawCountryCodeText	1	1	Simple	RawStateCodeText	0	1	Simple	RawStreetAddress1Text	0	1	Simple	RawZIPCode	0	1	Simple
Name	minOccurs	maxOccurs	Content																										
RawCityText	0	1	Simple																										
RawCountryCodeText	1	1	Simple																										
RawStateCodeText	0	1	Simple																										
RawStreetAddress1Text	0	1	Simple																										
RawZIPCode	0	1	Simple																										
Attribute(s)	<p>The following attributes must be recorded for this element:</p> <table border="1"> <thead> <tr> <th>Name</th> <th>Description</th> </tr> </thead> <tbody> <tr> <td>SeqNum</td> <td>The value recorded for this attribute must be numeric and unique. It may contain any numeric value up to 19 characters in length.</td> </tr> </tbody> </table>					Name	Description	SeqNum	The value recorded for this attribute must be numeric and unique. It may contain any numeric value up to 19 characters in length.																				
Name	Description																												
SeqNum	The value recorded for this attribute must be numeric and unique. It may contain any numeric value up to 19 characters in length.																												
Parent Element:	Party																												
Element Restriction(s):	Required. This element must be recorded when the parent element is recorded for the branch location.																												
Value Restriction(s):	n/a																												
Remarks:	<p>The batch submission will be <u>rejected</u> if any of the following conditions are true:</p> <ul style="list-style-type: none"> The element is missing a "SeqNum" attribute. The element contains a "SeqNum" attribute with a duplicate or invalid value. <p>The batch submission will be <u>accepted with warnings</u> if any of the following conditions are true:</p> <ul style="list-style-type: none"> The element is not recorded for the branch location. 																												
Example:	<pre><fc2:Address SeqNum="59"> <fc2:RawCityText>Cityville</fc2:RawCityText> <fc2:RawCountryCodeText>US</fc2:RawCountryCodeText> <fc2:RawStateCodeText>VA</fc2:RawStateCodeText> <fc2:RawStreetAddress1Text> 123 Address Way</fc2:RawStreetAddress1Text> <fc2:RawZIPCode> 547898856</fc2:RawZIPCode> </fc2:Address></pre>																												

Element Name:	RawCityText	minOccurs:	0	maxOccurs:	1
Description:	<p>City (text). This element identifies the city associated with the address of the branch. This element corresponds with the following item(s):</p> <ul style="list-style-type: none"> Branch: 71. City <p><i>Please refer to Attachment C for additional information regarding the above item(s).</i></p>				
Attribute(s)	n/a				
Parent Element:	Address				
Element Restriction(s):	Record this element for the Branch (46) where activity occurred party type when the city associated with the branch address is known; otherwise, do not record this element.				
Value Restriction(s):	The value provided must adhere to the following requirements: 50 characters or less				

Element Name:	RawCityText	minOccurs:	0	maxOccurs:	1
Remarks:	<ul style="list-style-type: none"> None 				
Example:	<fc2:RawCityText>Rockville</fc2:RawCityText>				

Element Name:	RawCountryCodeText	minOccurs:	1	maxOccurs:	1
Description:	Country (code). This element identifies the country associated with the branch. This element corresponds with the following item(s): <ul style="list-style-type: none"> Branch: 74. Country <i>Please refer to Attachment C for additional information regarding the above item(s).</i>				
Attribute(s)	n/a				
Parent Element:	Address				
Element Restriction(s):	Required. This element must be recorded if the parent element is recorded.				
Value Restriction(s):	The value provided must adhere to the following requirements: Country codes (including U.S. Territory codes) must adhere to the two-letter country codes found in ISO 3166-2.				
Remarks:	The batch submission will be <u>rejected</u> if any of the following conditions are true: <ul style="list-style-type: none"> The value recorded is not a valid country code. The batch submission will be <u>accepted with warning</u> if any of the following conditions are true: <ul style="list-style-type: none"> The element is not recorded or does not contain a value. State code and country code mismatch when U.S. Territory is recorded. 				
Example:	<fc2:RawCountryCodeText>US</fc2:RawCountryCodeText>				

Element Name:	RawStateCodeText	minOccurs:	0	maxOccurs:	1
Description:	State/Territory/Province (code). This element identifies the state/territory/province associated with the address of the branch when the corresponding country is equal to US (United States), CA (Canada), MX (Mexico), or a U.S. Territory. This element corresponds with the following item(s): <ul style="list-style-type: none"> Branch: 72. State <i>Please refer to Attachment C for additional information regarding the above item(s).</i>				
Attribute(s)	n/a				
Parent Element:	Address				
Element Restriction(s):	Record this element for the Branch (46) where activity occurred party type and the corresponding country is US (United States), CA (Canada), MX (Mexico), or a U.S. Territory*; otherwise, do not record this element. *If the country is a U.S. Territory, record the same U.S. Territory code for the state.				
Value Restriction(s):	The value provided must adhere to the following requirements: United States state/territory codes must adhere to the two-letter codes used by the United States Postal Service when the country is equal to US or a U.S. Territory. If a U.S. Territory is recorded for the country, it must also be recorded for the state. Canadian province/territory codes must adhere to the two-letter codes used by the Canadian Post Corporation when the country is equal to CA. Mexican state/federal district codes must adhere to the standards of ISO 3166-2:MX when the country is equal to MX.				
Remarks:	The batch submission will be <u>rejected</u> if any of the following conditions are true: <ul style="list-style-type: none"> The value recorded is not a valid country code. The batch submission will be <u>accepted with warning</u> if any of the following conditions are true: <ul style="list-style-type: none"> The element contains a value and the country is not US, CA, MX, or a U.S. Territory. The element is not recorded or does not contain a value when the country is US, CA, MX, or a U.S. Territory. State code and country code mismatch when U.S. Territory is recorded. 				
Example:	<fc2:RawStateCodeText>VA</fc2:RawStateCodeText>				

Element Name:	RawStreetAddress1Text	minOccurs:	0	maxOccurs:	1
Description:	<p>Street address (text). This element identifies the street address of the branch. This element corresponds with the following item(s):</p> <ul style="list-style-type: none"> Branch: 69. Street Address <p><i>Please refer to Attachment C for additional information regarding the above item(s).</i></p>				
Attribute(s)	n/a				
Parent Element:	Address				
Element Restriction(s):	Record this element for the Branch (46) where activity occurred party type when the street address associated with the branch address is known; otherwise, do not record this element.				
Value Restriction(s):	The value provided must adhere to the following requirements: 100 characters or less				
Remarks:	<ul style="list-style-type: none"> None 				
Example:	<fc2:RawStreetAddress1Text> 123 Address Way</fc2:RawStreetAddress1Text>				

Element Name:	RawZIPCode	minOccurs:	0	maxOccurs:	1
Description:	<p>ZIP/Postal Code (text). This element identifies the ZIP Code or foreign postal code associated with the address of the branch. This element corresponds with the following item(s):</p> <ul style="list-style-type: none"> Branch: 73. ZIP/Postal Code <p><i>Please refer to Attachment C for additional information regarding the above item(s).</i></p>				
Attribute(s)	n/a				
Parent Element:	Address				
Element Restriction(s):	Record this element for the Branch (46) where activity occurred party type when the ZIP/Postal Code associated with the branch address is known; otherwise, do not record this element.				
Value Restriction(s):	The value provided must adhere to the following requirements: For a U.S. address (including U.S. Territories): 5 or 9 numeric character entry; 9 numeric character entry cannot end with four zeros or four nines. For a non-U.S. address: 9 (or less) character entry. Do not include punctuation or formatting such as hyphens, periods, and spaces within the value entry				
Remarks:	<ul style="list-style-type: none"> None 				
Example:	<fc2:RawZIPCode> 547898856</fc2:RawZIPCode>				

4.6.8.1.2. PartyIdentification Elements

Element Name:	PartyIdentification	minOccurs:	0	maxOccurs:	1												
Description:	<p>Party identification (header). This is the container for information about the identification associated with the branch, specifically, the Research, Statistics, Supervision, and Discount (RSSD) number.</p> <p>The following tables describe all possible sub-elements for the Branch (46) party type:</p> <ol style="list-style-type: none"> Branch: RSSD number (FinCEN SAR Part III, Item 70) <table border="1" data-bbox="443 1556 1421 1682"> <thead> <tr> <th>Name</th> <th>minOccurs</th> <th>maxOccurs</th> <th>Content</th> </tr> </thead> <tbody> <tr> <td>PartyIdentificationNumberText (Item 70)</td> <td>1</td> <td>1</td> <td>Simple</td> </tr> <tr> <td>PartyIdentificationTypeCode (Item 70)</td> <td>1</td> <td>1</td> <td>Simple</td> </tr> </tbody> </table> <p><i>*If the <PartyIdentification> element is recorded for the Branch (46) party type, then the above elements must contain a valid value for each.</i></p>					Name	minOccurs	maxOccurs	Content	PartyIdentificationNumberText (Item 70)	1	1	Simple	PartyIdentificationTypeCode (Item 70)	1	1	Simple
Name	minOccurs	maxOccurs	Content														
PartyIdentificationNumberText (Item 70)	1	1	Simple														
PartyIdentificationTypeCode (Item 70)	1	1	Simple														
Attribute(s)	<p>The following attributes must be recorded for this element:</p> <table border="1" data-bbox="443 1795 1385 1837"> <thead> <tr> <th>Name</th> <th>Description</th> </tr> </thead> <tbody> <tr> <td> </td> <td> </td> </tr> </tbody> </table>					Name	Description										
Name	Description																

Element Name:	PartyIdentification	minOccurs:	0	maxOccurs:	1
	SeqNum	The value recorded for this attribute must be numeric and unique. It may contain any numeric value up to 19 characters in length.			
Parent Element:	Party				
Element Restriction(s):	Record this element if the RSSD number is known for the Branch (46) party type; otherwise, do not record this element.				
Value Restriction(s):	n/a				
Remarks:	The batch submission will be <u>rejected</u> if any of the following conditions are true: <ul style="list-style-type: none"> The element is missing a "SeqNum" attribute. The element contains a "SeqNum" attribute with a duplicate or invalid value. 				
Example:	<pre><fc2:PartyIdentification SeqNum="60"> <fc2:PartyIdentificationNumberText>445564615654</fc2:PartyIdentificationNumberText> <fc2:PartyIdentificationTypeCode>14</fc2:PartyIdentificationTypeCode> </fc2:PartyIdentification></pre>				

Element Name:	PartyIdentificationNumberText	minOccurs:	1	maxOccurs:	1
Description:	Identification number (text). This element identifies the RSSD number associated with the branch. This element corresponds with the following item(s): <ul style="list-style-type: none"> Branch: 70. RSSD number <i>Please refer to Attachment C for additional information regarding the above item(s).</i>				
Attribute(s)	n/a				
Parent Element:	PartyIdentification				
Element Restriction(s):	Required. This element must be recorded if the parent element is recorded.				
Value Restriction(s):	The value provided must adhere to the following requirements: 20 numeric characters or less				
Remarks:	The batch submission will be <u>accepted with warning</u> if any of the following conditions are true: <ul style="list-style-type: none"> The element is not recorded or does not contain a value. 				
Example:	<pre><fc2:PartyIdentificationNumberText>445564615654</fc2:PartyIdentificationNumberText></pre>				

Element Name:	PartyIdentificationTypeCode	minOccurs:	1	maxOccurs:	1
Description:	Identification type (code). This element identifies the type of identification number associated with the branch as an "RSSD" number. This element corresponds with the following item(s): <ul style="list-style-type: none"> Branch: 70. RSSD number <i>Please refer to Attachment C for additional information regarding the above item(s).</i>				
Attribute(s)	n/a				
Parent Element:	PartyIdentification				
Element Restriction(s):	Required. This element must be recorded if the parent element is recorded.				
Value Restriction(s):	The value provided must adhere to the following requirements: "14" (to identify the number recorded as the RSSD number)				
Remarks:	The batch submission will be <u>rejected</u> if any of the following conditions are true: <ul style="list-style-type: none"> The element is not recorded or does not contain a value The value recorded is not equal to "14". 				
Example:	<pre><fc2:PartyIdentificationTypeCode>14</fc2:PartyIdentificationTypeCode></pre>				

ALERT: This is the end of the elements associated with the Part III Branch location where activity occurred. The following PartyAccountAssociation element corresponds with the Subject party type only.

4.6.9. PartyAccountAssociation Elements

The following PartyAccountAssociation element (and associated sub-elements) corresponds with the Part I Item 27 Financial institution TIN and account number(s) affected that are related to the subject. This element should not be recorded for the subject in the event that there are no known accounts involved related to the subject (in which case the NoKnownAccountInvolvedIndicator element would be recorded with a "Y" value for the subject). Please refer to the Item 27 Item Instructions (Attachment C) for additional information.

Element Name:	PartyAccountAssociation	minOccurs:	0	maxOccurs:	1												
Description:	<p>Party account association (header). This is the container element for information about the financial institution and account(s) related to the subject.</p> <p>The following sub-element is associated with this element:</p> <div style="border: 1px solid black; background-color: #e1f5fe; padding: 5px; text-align: center;"> <p>Activity party type code definitions 33 = Subject</p> </div> <ol style="list-style-type: none"> Subject: Financial institution TIN and account number(s) affected that are related to the subject (if any) (FinCEN SAR Part I, Item 27b-e) <table border="1" style="width: 100%; border-collapse: collapse;"> <thead> <tr style="background-color: #e1f5fe;"> <th>Name</th> <th>minOccurs</th> <th>maxOccurs</th> <th>Content</th> </tr> </thead> <tbody> <tr> <td>PartyAccountAssociationTypeCode (Code 7)</td> <td style="text-align: center;">1</td> <td style="text-align: center;">1</td> <td>Simple</td> </tr> <tr> <td>Party (Items 27b-e)</td> <td style="text-align: center;">1</td> <td style="text-align: center;">99</td> <td>Complex</td> </tr> </tbody> </table> <p><i>*If the <PartyAccountAssociation> element is recorded for the Subject (33), then the above elements must be recorded.</i></p>					Name	minOccurs	maxOccurs	Content	PartyAccountAssociationTypeCode (Code 7)	1	1	Simple	Party (Items 27b-e)	1	99	Complex
Name	minOccurs	maxOccurs	Content														
PartyAccountAssociationTypeCode (Code 7)	1	1	Simple														
Party (Items 27b-e)	1	99	Complex														
Attribute(s)	<p>The following attributes must be recorded for this element:</p> <table border="1" style="width: 100%; border-collapse: collapse;"> <thead> <tr style="background-color: #e1f5fe;"> <th>Name</th> <th>Description</th> </tr> </thead> <tbody> <tr> <td>SeqNum</td> <td>The value recorded for this attribute must be numeric and unique. It may contain any numeric value up to 19 characters in length.</td> </tr> </tbody> </table>					Name	Description	SeqNum	The value recorded for this attribute must be numeric and unique. It may contain any numeric value up to 19 characters in length.								
Name	Description																
SeqNum	The value recorded for this attribute must be numeric and unique. It may contain any numeric value up to 19 characters in length.																
Parent Element:	Party																
Element Restriction(s):	Conditionally Required. Record this element for the Subject (33) party type when information about account(s) involved in the suspicious activity (related to the subject) exist; otherwise do not record this element and record the <NoKnownAccountInvolvedIndicator> element with a "Y" value. An account is related to a subject if the subject owns the account, has control over the account, or conducted activity in or through an account the subject does not own or control.																
Value Restriction(s):	n/a																
Remarks:	<p>The batch submission will be rejected if any of the following conditions are true:</p> <ul style="list-style-type: none"> The element is recorded for a party type that is not applicable to this data (see Element Restrictions for more information). The element is missing a "SeqNum" attribute. The element contains a "SeqNum" attribute with a duplicate or invalid value. <p>The batch submission will be accepted with warning if any of the following conditions are true:</p> <ul style="list-style-type: none"> The element is recorded but the <NoKnownAccountInvolvedIndicator> element is also recorded with a "Y" value. The element is not recorded and the <NoKnownAccountInvolvedIndicator> element is not recorded with a "Y" value. 																
Example:	<pre><fc2:PartyAccountAssociation SeqNum="79"> <fc2:PartyAccountAssociationTypeCode>7</fc2:PartyAccountAssociationTypeCode> </fc2:Party SeqNum="80"></pre>																

Element Name:	PartyAccountAssociationTypeCode	minOccurs:	1	maxOccurs:	1
Description:	Party account association type (code). This element is for FinCEN purposes only.				
Attribute(s)	n/a				
Parent Element:	PartyAccountAssociation				
Element Restriction(s):	Required. This element must be recorded when the parent element is recorded.				
Value Restriction(s):	The value provided must adhere to the following requirements: "7" (to link the subject to the account)				
Remarks:	The batch submission will be <u>rejected</u> if any of the following conditions are true: <ul style="list-style-type: none"> The element is not recorded or does not contain a value. The value recorded is not equal to "7". 				
Example:	<fc2:PartyAccountAssociationTypeCode>7</fc2:PartyAccountAssociationTypeCode>				

Element Name:	Party	See <i>Party Elements (below)</i> for details.
---------------	-------	--

4.6.9.1. Party Elements

The following Party element (and associated sub-elements) corresponds with the Part I Item 27 Financial institution TIN and account number(s) affected that are related to the subject. Unless there are no known accounts involved related to a subject (in which case the NoKnownAccountInvolvedIndicator element is recorded with a "Y" value for the subject and, as a result, the PartyAccountAssociation element is not recorded), up to 99 financial institutions' where account(s) are held may be reported for each subject. Please refer to the Item 27 Item Instructions (Attachment C) for additional information.

Element Name:	Party	minOccurs:	1	maxOccurs:	99																				
Description:	Party (header). This is the container for information about the financial institution in which the account related to the subject is held. The following sub-element is associated with this element: <div style="background-color: #e1f5fe; padding: 5px; text-align: center;"> Activity party type code definitions 41 = Financial institution where account is held </div> <ol style="list-style-type: none"> Subject: Financial institution TIN (FinCEN SAR Part I, Item 27b-c) <table border="1" style="width: 100%; border-collapse: collapse;"> <thead> <tr> <th style="width: 60%;">Name</th> <th style="width: 10%;">minOccurs</th> <th style="width: 10%;">maxOccurs</th> <th style="width: 20%;">Content</th> </tr> </thead> <tbody> <tr> <td>ActivityPartyTypeCode (Code 41)</td> <td style="text-align: center;">1</td> <td style="text-align: center;">1</td> <td>Simple</td> </tr> <tr> <td>NonUSFinancialInstitutionIndicator (Item 27b)</td> <td style="text-align: center;">0</td> <td style="text-align: center;">1</td> <td>Simple</td> </tr> <tr> <td>PartyIdentification (Item 27c)</td> <td style="text-align: center;">0</td> <td style="text-align: center;">1</td> <td>Complex</td> </tr> <tr> <td>Account (Item 27 d-e)</td> <td style="text-align: center;">0</td> <td style="text-align: center;">99</td> <td>Complex</td> </tr> </tbody> </table>					Name	minOccurs	maxOccurs	Content	ActivityPartyTypeCode (Code 41)	1	1	Simple	NonUSFinancialInstitutionIndicator (Item 27b)	0	1	Simple	PartyIdentification (Item 27c)	0	1	Complex	Account (Item 27 d-e)	0	99	Complex
Name	minOccurs	maxOccurs	Content																						
ActivityPartyTypeCode (Code 41)	1	1	Simple																						
NonUSFinancialInstitutionIndicator (Item 27b)	0	1	Simple																						
PartyIdentification (Item 27c)	0	1	Complex																						
Account (Item 27 d-e)	0	99	Complex																						
Attribute(s)	The following attributes must be recorded for this element: <table border="1" style="width: 100%; border-collapse: collapse; margin-top: 5px;"> <thead> <tr> <th style="width: 20%;">Name</th> <th>Description</th> </tr> </thead> <tbody> <tr> <td>SeqNum</td> <td>The value recorded for this attribute must be numeric and unique. It may contain any numeric value up to 19 characters in length.</td> </tr> </tbody> </table>					Name	Description	SeqNum	The value recorded for this attribute must be numeric and unique. It may contain any numeric value up to 19 characters in length.																
Name	Description																								
SeqNum	The value recorded for this attribute must be numeric and unique. It may contain any numeric value up to 19 characters in length.																								
Parent Element:	PartyAccountAssociation																								
Element Restriction(s):	Required. This element must be recorded when the parent element is recorded.																								
Value Restriction(s):	n/a																								
Remarks:	The batch submission will be <u>rejected</u> if any of the following conditions are true: <ul style="list-style-type: none"> The element is not recorded. 																								

Element Name:	Party	minOccurs:	1	maxOccurs:	99
	<ul style="list-style-type: none"> The element is missing a "SeqNum" attribute. The element contains a "SeqNum" attribute with a duplicate or invalid value. More than 99 Financial Institutions Where Account is Held are recorded for the FinCEN SAR. 				
Example:	See Part Elements by Party Type for a detailed example...				

Element Name:	ActivityPartyTypeCode	minOccurs:	1	maxOccurs:	1				
Description:	Party type (code). This element identifies the type of party associated with the FinCEN SAR; specifically the financial institution where the account is held.								
Attribute(s)	n/a								
Parent Element:	Party								
Element Restriction(s):	Required. This element must be recorded for each <Party> element regardless of party type.								
Value Restriction(s):	The value provided must adhere to the following requirements:								
	<table border="1"> <thead> <tr> <th>Code</th> <th>Description</th> </tr> </thead> <tbody> <tr> <td>41</td> <td>Financial institution where account is held</td> </tr> </tbody> </table>					Code	Description	41	Financial institution where account is held
Code	Description								
41	Financial institution where account is held								
Remarks:	The batch submission will be <u>rejected</u> if any of the following conditions are true: <ul style="list-style-type: none"> The element is not recorded. The element is recorded but with no value (i.e. the value is null). The element contains a value not equal to "41". 								
Example:	<fc2:ActivityPartyTypeCode>41</fc2:ActivityPartyTypeCode>								

Element Name:	NonUSFinancialInstitutionIndicator	minOccurs:	0	maxOccurs:	1
Description:	Non-U.S. financial institution (indicator). This element declares that the account is located at a foreign financial institution. This element corresponds with the following item(s): <ul style="list-style-type: none"> 27b. Non-U.S. financial institution <i>Please refer to Attachment C for additional information regarding the above item(s).</i>				
Attribute(s)	n/a				
Parent Element:	Party				
Element Restriction(s):	Record this element when the Financial institution where the account is held (41) party type and the location of the institution is not within the U.S. or a U.S. Territory; otherwise, do not record this element.				
Value Restriction(s):	The value provided must adhere to the following requirements: "Y" (to indicate "Non U.S. financial institution")				
Remarks:	The batch submission will be <u>rejected</u> if any of the following conditions are true: <ul style="list-style-type: none"> The value recorded is not equal to "Y" or not equal to null. 				
Example:	<fc2:NonUSFinancialInstitutionIndicator>Y</fc2:NonUSFinancialInstitutionIndicator>				

Element Name:	PartyIdentification	See <i>PartyIdentification Elements (below)</i> for details.			
---------------	---------------------	--	--	--	--

Element Name:	Account	See <i>Account Elements (below)</i> for details.			
---------------	---------	--	--	--	--

4.6.9.1.1. PartyIdentification Elements

Element Name:	PartyIdentification	minOccurs:	0	maxOccurs:	1
Description:	Party identification (header). This is the container for information about the TIN associated with the financial institution in which the account is held.				

Element Name:	PartyIdentification	minOccurs:	0	maxOccurs:	1												
	<p>The following sub-element is associated with this element:</p> <div style="border: 1px solid black; padding: 5px; margin: 5px 0;"> <p style="text-align: center;">Activity party type code definitions</p> <p style="text-align: center;">41 = Financial institution where account is held</p> </div> <p>1. Subject: Financial institution TIN (FinCEN SAR Part I, Item 27c)</p> <table border="1" style="width: 100%; border-collapse: collapse;"> <thead> <tr> <th style="text-align: left;">Name</th> <th style="text-align: center;">minOccurs</th> <th style="text-align: center;">maxOccurs</th> <th style="text-align: left;">Content</th> </tr> </thead> <tbody> <tr> <td>PartyIdentificationNumberText (Item 27c)</td> <td style="text-align: center;">1</td> <td style="text-align: center;">1</td> <td>Simple</td> </tr> <tr> <td>PartyIdentificationTypeCode (Code 4)</td> <td style="text-align: center;">1</td> <td style="text-align: center;">1</td> <td>Simple</td> </tr> </tbody> </table>					Name	minOccurs	maxOccurs	Content	PartyIdentificationNumberText (Item 27c)	1	1	Simple	PartyIdentificationTypeCode (Code 4)	1	1	Simple
Name	minOccurs	maxOccurs	Content														
PartyIdentificationNumberText (Item 27c)	1	1	Simple														
PartyIdentificationTypeCode (Code 4)	1	1	Simple														
Attribute(s)	<p>The following attributes must be recorded for this element:</p> <table border="1" style="width: 100%; border-collapse: collapse;"> <thead> <tr> <th style="text-align: left;">Name</th> <th style="text-align: left;">Description</th> </tr> </thead> <tbody> <tr> <td>SeqNum</td> <td>The value recorded for this attribute must be numeric and unique. It may contain any numeric value up to 19 characters in length.</td> </tr> </tbody> </table>					Name	Description	SeqNum	The value recorded for this attribute must be numeric and unique. It may contain any numeric value up to 19 characters in length.								
Name	Description																
SeqNum	The value recorded for this attribute must be numeric and unique. It may contain any numeric value up to 19 characters in length.																
Parent Element:	Party																
Element Restriction(s):	Record this element when the TIN of the financial institution where the account is held is known; otherwise, do not record this element.																
Value Restriction(s):	n/a																
Remarks:	<p>The batch submission will be <u>rejected</u> if any of the following conditions are true:</p> <ul style="list-style-type: none"> The element is missing a "SeqNum" attribute. The element contains a "SeqNum" attribute with a duplicate or invalid value. 																
Example:	<pre><fc2:PartyIdentification SeqNum="81"> <fc2:PartyIdentificationNumberText>458789856</fc2:PartyIdentificationNumberText> <fc2:PartyIdentificationTypeCode>4</fc2:PartyIdentificationTypeCode> </fc2:PartyIdentification></pre>																

Element Name:	PartyIdentificationNumberText	minOccurs:	1	maxOccurs:	1
Description:	<p>Identification number (text). This element identifies the Taxpayer Identification Number (TIN) associated with the financial institution in which the account is held. This element corresponds with the following item(s):</p> <ul style="list-style-type: none"> 27c. Financial Institution TIN related to subject <p><i>Please refer to Attachment C for additional information regarding the above item(s).</i></p>				
Attribute(s)	n/a				
Parent Element:	PartyIdentification				
Element Restriction(s):	Required. Record this element if the parent element is recorded.				
Value Restriction(s):	The value provided must adhere to the following requirements: 25 characters or less. Identification numbers must be entered as a single alpha/numeric text string without formatting or special characters such as, for example, spaces, hyphens, or periods. Cannot be consecutive string of the same number or an incremental string such as 123456789.				
Remarks:	<p>The batch submission will be <u>accepted with warning</u> if any of the following conditions are true:</p> <ul style="list-style-type: none"> The element is not recorded or does not contain a value. 				
Example:	<pre><fc2:PartyIdentificationNumberText>458789856</fc2:PartyIdentificationNumberText></pre>				

Element Name:	PartyIdentificationTypeCode	minOccurs:	1	maxOccurs:	1
Description:	Identification type (code). This element identifies the type of identification number associated with financial institution in which the account is held as a "TIN." This element corresponds with the following item(s): <ul style="list-style-type: none"> • 27c. Financial Institution TIN type related to subject Please refer to Attachment C for additional information regarding the above item(s).				
Attribute(s)	n/a				
Parent Element:	PartyIdentification				
Element Restriction(s):	Required. Record this element if the parent element is recorded.				
Value Restriction(s):	The value provided must adhere to the following requirements: "4" (to indicate TIN)				
Remarks:	The batch submission will be <u>rejected</u> if any of the following conditions are true: <ul style="list-style-type: none"> • The element is not recorded or does not contain a value. • The value recorded does not equal "4". 				
Example:	<fc2:PartyIdentificationTypeCode>4</fc2:PartyIdentificationTypeCode>				

4.6.9.1.2. Account Elements

Element Name:	Account	minOccurs:	0	maxOccurs:	99												
Description:	Account (header). This is the container for information about the account (held at the corresponding financial institution) involved in the suspicious activity related to the recorded subject. <p>The following sub-element is associated with this element:</p> <div style="background-color: #e1f5fe; padding: 10px; text-align: center;"> Activity party type code definitions 41 = Financial institution where account is held </div> <ol style="list-style-type: none"> Subject: Financial institution TIN (FinCEN SAR Part I, Item 27 d-e) <table border="1" style="width: 100%; border-collapse: collapse;"> <thead> <tr> <th style="width: 60%;">Name</th> <th style="width: 10%;">minOccurs</th> <th style="width: 10%;">maxOccurs</th> <th style="width: 20%;">Content</th> </tr> </thead> <tbody> <tr> <td>AccountNumberText (Item 27d)</td> <td style="text-align: center;">1</td> <td style="text-align: center;">1</td> <td>Simple</td> </tr> <tr> <td>PartyAccountAssociation (Item 27e)</td> <td style="text-align: center;">1</td> <td style="text-align: center;">1</td> <td>Complex</td> </tr> </tbody> </table>					Name	minOccurs	maxOccurs	Content	AccountNumberText (Item 27d)	1	1	Simple	PartyAccountAssociation (Item 27e)	1	1	Complex
Name	minOccurs	maxOccurs	Content														
AccountNumberText (Item 27d)	1	1	Simple														
PartyAccountAssociation (Item 27e)	1	1	Complex														
Attribute(s)	The following attributes must be recorded for this element: <table border="1" style="width: 100%; border-collapse: collapse;"> <thead> <tr> <th style="width: 20%;">Name</th> <th>Description</th> </tr> </thead> <tbody> <tr> <td>SeqNum</td> <td>The value recorded for this attribute must be numeric and unique. It may contain any numeric value up to 19 characters in length.</td> </tr> </tbody> </table>					Name	Description	SeqNum	The value recorded for this attribute must be numeric and unique. It may contain any numeric value up to 19 characters in length.								
Name	Description																
SeqNum	The value recorded for this attribute must be numeric and unique. It may contain any numeric value up to 19 characters in length.																
Parent Element:	Party																
Element Restriction(s):	Record this element for the Financial institution where the account is held (41) party type when the account number involved in the suspicious activity (related to the subject*) is known**; otherwise do not record this element. <p>*An account is related to a subject if the subject owns the account, has control over the account, or conducted activity in or through an account the subject does not own or control.</p> <p>**If the filer is aware that the subject has an account involved in the suspicious activity with the recorded financial institution but the account number is unknown, record the <PartyIdentificationNumberText> element with the TIN of the financial institution (41) party type and</p>																

Element Name:	Account	minOccurs:	0	maxOccurs:	99
	do not record the <Account> element. Provide an explanation for the missing account number in the narrative.				
Value Restriction(s):	n/a				
Remarks:	The batch submission will be <u>rejected</u> if any of the following conditions are true: <ul style="list-style-type: none"> The element is missing a "SeqNum" attribute. The element contains a "SeqNum" attribute with a duplicate or invalid value. 				
Example:	<pre><fc2:Account SeqNum="82"> <fc2:AccountNumberText>1502417873</fc2:AccountNumberText> <fc2:PartyAccountAssociation SeqNum="83"></pre>				

Element Name:	AccountNumberText	minOccurs:	1	maxOccurs:	1
Description:	Account number (text). This element identifies the account number involved in the suspicious activity related to the recorded subject. This element corresponds with the following item(s): <ul style="list-style-type: none"> 27d. Account number <i>Please refer to Attachment C for additional information regarding the above item(s).</i>				
Attribute(s)	n/a				
Parent Element:	Account				
Element Restriction(s):	Required. This element must be recorded when the <Account> parent element is recorded.				
Value Restriction(s):	The value provided must adhere to the following requirements: 40 characters or less				
Remarks:	The batch submission will be <u>accepted with warning</u> if any of the following conditions are true: <ul style="list-style-type: none"> The element is not recorded or does not contain a value. 				
Example:	<fc2:AccountNumberText>1502417873</fc2:AccountNumberText>				

Element Name:	PartyAccountAssociation	See <i>PartyAccountAssociation Elements (below)</i> for details.			
---------------	-------------------------	--	--	--	--

4.6.9.1.3. PartyAccountAssociation Elements

Element Name:	PartyAccountAssociation	minOccurs:	1	maxOccurs:	1												
Description:	Party account association (header). This is the container for creating the association of the account to the Financial institution where the account is held, as well as indicating whether or not the account is closed. <p>The following sub-element is associated with this element:</p> <div style="background-color: #e1f5fe; padding: 10px; text-align: center;"> <p>Activity party type code definitions</p> <p>41 = Financial institution where account is held</p> </div> <ol style="list-style-type: none"> Subject: Financial institution TIN and account number(s) affected that are related to the subject (if any) (FinCEN SAR Part I, Item 27e) <table border="1" style="width: 100%; border-collapse: collapse;"> <thead> <tr> <th style="width: 60%;">Name</th> <th style="width: 10%;">minOccurs</th> <th style="width: 10%;">maxOccurs</th> <th style="width: 20%;">Content</th> </tr> </thead> <tbody> <tr> <td>AccountClosedIndicator</td> <td style="text-align: center;">0</td> <td style="text-align: center;">1</td> <td>Simple</td> </tr> <tr> <td>PartyAccountAssociationTypeCode (Code 5)</td> <td style="text-align: center;">1</td> <td style="text-align: center;">1</td> <td>Simple</td> </tr> </tbody> </table>					Name	minOccurs	maxOccurs	Content	AccountClosedIndicator	0	1	Simple	PartyAccountAssociationTypeCode (Code 5)	1	1	Simple
Name	minOccurs	maxOccurs	Content														
AccountClosedIndicator	0	1	Simple														
PartyAccountAssociationTypeCode (Code 5)	1	1	Simple														
Attribute(s)	The following attributes must be recorded for this element: <table border="1" style="width: 100%; border-collapse: collapse;"> <thead> <tr> <th style="width: 20%;">Name</th> <th style="width: 80%;">Description</th> </tr> </thead> <tbody> <tr> <td> </td> <td> </td> </tr> </tbody> </table>					Name	Description										
Name	Description																

Element Name:	PartyAccountAssociation	minOccurs:	1	maxOccurs:	1
	SeqNum	The value recorded for this attribute must be numeric and unique. It may contain any numeric value up to 19 characters in length.			
Parent Element:	Account				
Element Restriction(s):	Required. This element must be recorded when the parent element is recorded.				
Value Restriction(s):	n/a				
Remarks:	<p>The batch submission will be <u>rejected</u> if any of the following conditions are true:</p> <ul style="list-style-type: none"> • The element is not recorded. • The element is missing a "SeqNum" attribute. • The element contains a "SeqNum" attribute with a duplicate or invalid value. 				
Example:	<pre><fc2:PartyAccountAssociation SeqNum="83"> <fc2:AccountClosedIndicator>Y</fc2:AccountClosedIndicator> <fc2:PartyAccountAssociationTypeCode>5</fc2:PartyAccountAssociationTypeCode> </fc2:PartyAccountAssociation></pre>				

Element Name:	AccountClosedIndicator	minOccurs:	0	maxOccurs:	1
Description:	<p>Account closed (indicator). This element declares that the recorded account is closed. This element corresponds with the following item(s):</p> <ul style="list-style-type: none"> • 27e. Account closed <p><i>Please refer to Attachment C for additional information regarding the above item(s).</i></p>				
Attribute(s)	n/a				
Parent Element:	PartyAccountAssociation				
Element Restriction(s):	Record this element for the Financial institution where the account is held (41) party type when the associated account is closed; otherwise, do not record this element.				
Value Restriction(s):	The value provided must adhere to the following requirements: "Y" (to indicate "Account closed")				
Remarks:	<p>The batch submission will be <u>rejected</u> if any of the following conditions are true:</p> <ul style="list-style-type: none"> • The element contains a value not equal to "Y" or null. 				
Example:	<pre><fc2:AccountClosedIndicator>Y</fc2:AccountClosedIndicator></pre>				

Element Name:	PartyAccountAssociationTypeCode	minOccurs:	1	maxOccurs:	1
Description:	Party account association type (code). This element is for FinCEN purposes only.				
Attribute(s)	n/a				
Parent Element:	PartyAccountAssociation				
Element Restriction(s):	Required. This element must be recorded when the parent element is recorded.				
Value Restriction(s):	The value provided must adhere to the following requirements: "5" (to link the Financial institution to the account)				
Remarks:	<p>The batch submission will be <u>rejected</u> if any of the following conditions are true:</p> <ul style="list-style-type: none"> • The element is not recorded or does not contain a value. • The value recorded is not equal to "5". 				
Example:	<pre><fc2:PartyAccountAssociationTypeCode>5</fc2:PartyAccountAssociationTypeCode></pre>				

ALERT: This is the end of the elements associated with the Part I Item 27 Financial institution TIN and account number(s) affected that are related to the subject. The following SuspiciousActivity element corresponds with the FinCEN SAR activity.

4.7. SuspiciousActivity Elements

Element Name:	SuspiciousActivity	minOccurs:	1	maxOccurs:	1																																
Description:	<p>Suspicious Activity (header). This element is the container for information about the suspicious activity, such as the total amount involved and the type of suspicious activity.</p> <p>The following sub-element is associated with this element:</p> <table border="1"> <thead> <tr> <th>Name</th> <th>minOccurs</th> <th>maxOccurs</th> <th>Category</th> </tr> </thead> <tbody> <tr> <td>AmountUnknownIndicator (Item 29a)</td> <td>0</td> <td>1</td> <td>Simple</td> </tr> <tr> <td>CumulativeTotalViolationAmountText (Item 31)</td> <td>0</td> <td>1</td> <td>Simple</td> </tr> <tr> <td>NoAmountInvolvedIndicator (Item 29b)</td> <td>0</td> <td>1</td> <td>Simple</td> </tr> <tr> <td>SuspiciousActivityFromDateText (Item 30a)</td> <td>1</td> <td>1</td> <td>Simple</td> </tr> <tr> <td>SuspiciousActivityToDateText (Item 30b)</td> <td>0</td> <td>1</td> <td>Simple</td> </tr> <tr> <td>TotalSuspiciousAmountText (Item 29)</td> <td>0</td> <td>1</td> <td>Simple</td> </tr> <tr> <td>SuspiciousActivityClassification (Items 32-42)</td> <td>1</td> <td>99</td> <td>Complex</td> </tr> </tbody> </table> <p>Please refer to Attachment C for additional information regarding the above item(s).</p>					Name	minOccurs	maxOccurs	Category	AmountUnknownIndicator (Item 29a)	0	1	Simple	CumulativeTotalViolationAmountText (Item 31)	0	1	Simple	NoAmountInvolvedIndicator (Item 29b)	0	1	Simple	SuspiciousActivityFromDateText (Item 30a)	1	1	Simple	SuspiciousActivityToDateText (Item 30b)	0	1	Simple	TotalSuspiciousAmountText (Item 29)	0	1	Simple	SuspiciousActivityClassification (Items 32-42)	1	99	Complex
Name	minOccurs	maxOccurs	Category																																		
AmountUnknownIndicator (Item 29a)	0	1	Simple																																		
CumulativeTotalViolationAmountText (Item 31)	0	1	Simple																																		
NoAmountInvolvedIndicator (Item 29b)	0	1	Simple																																		
SuspiciousActivityFromDateText (Item 30a)	1	1	Simple																																		
SuspiciousActivityToDateText (Item 30b)	0	1	Simple																																		
TotalSuspiciousAmountText (Item 29)	0	1	Simple																																		
SuspiciousActivityClassification (Items 32-42)	1	99	Complex																																		
Attribute(s)	<p>The following attributes must be recorded for this element:</p> <table border="1"> <thead> <tr> <th>Name</th> <th>Description</th> </tr> </thead> <tbody> <tr> <td>SeqNum</td> <td>The value recorded for this attribute must be numeric and unique. It may contain any numeric value up to 19 characters in length.</td> </tr> </tbody> </table>					Name	Description	SeqNum	The value recorded for this attribute must be numeric and unique. It may contain any numeric value up to 19 characters in length.																												
Name	Description																																				
SeqNum	The value recorded for this attribute must be numeric and unique. It may contain any numeric value up to 19 characters in length.																																				
Parent Element:	Activity																																				
Element Restriction(s):	Required. This element must be recorded.																																				
Value Restriction(s):	n/a																																				
Remarks:	<p>The batch submission will be <u>rejected</u> if any of the following conditions are true:</p> <ul style="list-style-type: none"> The element is not recorded. The element is missing a "SeqNum" attribute. The element contains a "SeqNum" attribute with a duplicate or invalid value. 																																				
Example:	<pre><fc2:SuspiciousActivity SeqNum="123"> <fc2:SuspiciousActivityFromDateText>20171001</fc2:SuspiciousActivityFromDateText> <fc2:SuspiciousActivityToDateText>20171030</fc2:SuspiciousActivityToDateText> <fc2:TotalSuspiciousAmountText>20000</fc2:TotalSuspiciousAmountText> <fc2:SuspiciousActivityClassification SeqNum="124"> <fc2:OtherSuspiciousActivityTypeText>other type of suspicious activity description</fc2:OtherSuspiciousActivityTypeText> <fc2:SuspiciousActivitySubTypeID>915</fc2:SuspiciousActivitySubTypeID> <fc2:SuspiciousActivityTypeID>9</fc2:SuspiciousActivityTypeID> </fc2:SuspiciousActivityClassification></pre>																																				

Element Name:	AmountUnknownIndicator	minOccurs:	0	maxOccurs:	1
Description:	<p>Amount unknown (indicator). This element declares that the total dollar amount involved in the FinCEN SAR for the time period being reported is unknown. This element corresponds with the following item(s):</p> <ul style="list-style-type: none"> 29a. Amount involved in this report (unknown) <p>Please refer to Attachment C for additional information regarding the above item(s).</p>				
Attribute(s)	n/a				
Parent Element:	SuspiciousActivity				
Element Restriction(s):	Record this element when the dollar amount involved in the FinCEN SAR being filed is unknown; otherwise, do not record this element. If unknown, provide an explanation as to why the dollar amount is unknown in narrative. If some dollar amounts are known while others are unknown, do not record the				

Element Name:	AmountUnknownIndicator	minOccurs:	0	maxOccurs:	1
	AmountUnknownIndicator element; instead, record the total of all known amounts in the TotalSuspiciousAmountText element and provide an explanation for the unknown amounts in the narrative.				
Value Restriction(s):	The value provided must adhere to the following requirements: "Y" (to indicate "Amount unknown")				
Remarks:	The batch submission will be <u>rejected</u> if any of the following conditions are true: <ul style="list-style-type: none"> The value recorded is not equal to "Y" or not equal to null. 				
Example:	<fc2:AmountUnknownIndicator>Y</fc2:AmountUnknownIndicator>				

Element Name:	CumulativeTotalViolationAmountText	minOccurs:	0	maxOccurs:	1
Description:	Cumulative amount (amount). This element identifies the cumulative amount (in whole U.S. dollars) involved in the suspicious activity. The cumulative amount represents the total amount involved in all FinCEN SARs filed on the suspicious activity, including the current FinCEN SAR being filed. This element corresponds with the following item(s): <ul style="list-style-type: none"> 31. Cumulative amount (only if continuing activity report is indicated) <i>Please refer to Attachment C for additional information regarding the above item(s).</i>				
Attribute(s)	n/a				
Parent Element:	SuspiciousActivity				
Element Restriction(s):	Conditionally Required. Record the CumulativeTotalViolationAmountText element if the FinCEN SAR being filed is a continuing activity report (i.e. the ContinuingActivityReportIndicator element is recorded with a "Y" value); otherwise, do not record this element.				
Value Restriction(s):	The value provided must adhere to the following requirements: 1-15 numeric characters (without leading zeros) denominated in whole U.S. Dollars. If the cumulative dollar amount is unknown because all dollar amounts are unknown or no dollar amount is involved, enter zero ("0") and provide an explanation in the narrative. If some dollar amounts are known while others are unknown, enter the total of all known amounts and explain the nature of the unknown amounts in the narrative.				
Remarks:	The batch submission will be <u>accepted with warnings</u> if any of the following conditions are true: <ul style="list-style-type: none"> The value recorded contains one or more non-numeric characters. The element is not recorded or does not contain a value and continuing activity report is indicated. The element is recorded with a value and continuing activity report is not indicated. The amount recorded is less than the total amount recorded for <TotalSuspiciousAmountText> 				
Example:	<fc2:CumulativeTotalViolationAmountText>30000</fc2:CumulativeTotalViolationAmountText>				

Element Name:	NoAmountInvolvedIndicator	minOccurs:	0	maxOccurs:	1
Description:	No amount involved (indicator). This element declares that there is no amount involved in the suspicious activity. This element corresponds with the following item(s): <ul style="list-style-type: none"> 29b. No amount involved <i>Please refer to Attachment C for additional information regarding the above item(s).</i>				
Attribute(s)	n/a				
Parent Element:	SuspiciousActivity				
Element Restriction(s):	Record this element when there is no amount involved in the suspicious activity; otherwise, do not record this element.				
Value Restriction(s):	The value provided must adhere to the following requirements: "Y" (to indicate "No amount involved")				
Remarks:	The batch submission will be <u>rejected</u> if any of the following conditions are true: <ul style="list-style-type: none"> The value recorded is not equal to "Y" or not equal to null. 				
Example:	<fc2:NoAmountInvolvedIndicator>Y</fc2:NoAmountInvolvedIndicator>				

Element Name:	SuspiciousActivityFromDateText	minOccurs:	1	maxOccurs:	1
Description:	Date or start date of suspicious activity. This element identifies either the date on which the suspicious activity occurred (in the event that the suspicious activity occurred on a single day) or the earliest date of suspicious activity (in the event that that suspicious activity occurred on multiple days). This element corresponds with the following item(s): <ul style="list-style-type: none"> 30a. Date or date range (from) of suspicious activity <i>Please refer to Attachment C for additional information regarding the above item(s).</i>				
Attribute(s)	n/a				
Parent Element:	SuspiciousActivity				
Element Restriction(s):	Required. This element must be recorded.				
Value Restriction(s):	The value provided must adhere to the following requirements: 8 numeric characters in the format YYYYMMDD where YYYY = year, MM = month, and DD = day. Single digit days or months must be prefaced by a zero. If the exact date(s) of the suspicious activity is (are) unknown, enter a date range that the filer believes will encompass the date(s) of the suspicious activity. Explain the nature of this date range in the narrative. If the FinCEN SAR involves continuing activity, enter only the date range covered by this FinCEN SAR. Record in the narrative the aggregated date range of all FinCEN SARs filed on the continuing suspicious activity.				
Remarks:	The batch submission will be <u>accepted with warning</u> if any of the following conditions are true: <ul style="list-style-type: none"> The element is not recorded or does not contain a value. The value recorded for the element is not in the required format (YYYYMMDD). The value recorded is greater than the date recorded for <SuspiciousActivityToDateText>. 				
Example:	<fc2:SuspiciousActivityFromDateText>20171001</fc2:SuspiciousActivityFromDateText>				

Element Name:	SuspiciousActivityToDateText	minOccurs:	0	maxOccurs:	1
Description:	End date of suspicious activity (when different from the start date). This element identifies the most-recent date of suspicious activity (in the event that that suspicious activity occurred on multiple days). This element corresponds with the following item(s): <ul style="list-style-type: none"> 30b. Date range (to) of suspicious activity <i>Please refer to Attachment C for additional information regarding the above item(s).</i>				
Attribute(s)	n/a				
Parent Element:	SuspiciousActivity				
Element Restriction(s):	Record this element when the suspicious activity occurred on multiple days (in which case this element will record the most-recent date of suspicious activity); otherwise, do not record this element.				
Value Restriction(s):	The value provided must adhere to the following requirements: 8 numeric characters in the format YYYYMMDD where YYYY = year, MM = month, and DD = day. Single digit days or months must be prefaced by a zero. If the exact date(s) of the suspicious activity is (are) unknown, enter a date range that the filer believes will encompass the date(s) of the suspicious activity. Explain the nature of this date range in the narrative. If the FinCEN SAR involves continuing activity, enter only the date range covered by this FinCEN SAR. Record in the narrative the aggregated date range of all FinCEN SARs filed on the continuing suspicious activity.				
Remarks:	The batch submission will be <u>accepted with warning</u> if any of the following conditions are true: <ul style="list-style-type: none"> The value recorded for the element is not in the required format (YYYYMMDD). 				
Example:	<fc2:SuspiciousActivityToDateText>20171030</fc2:SuspiciousActivityToDateText>				

Element Name:	TotalSuspiciousAmountText	minOccurs:	0	maxOccurs:	1
Description:	Total amount involved (amount). This element identifies the total amount (in whole U.S. dollars) involved in the suspicious activity for the time period of the report. This element corresponds with the following item(s): <ul style="list-style-type: none"> 29. Amount involved in this report 				

Element Name:	TotalSuspiciousAmountText	minOccurs:	0	maxOccurs:	1
	<i>Please refer to Attachment C for additional information regarding the above item(s).</i>				
Attribute(s)	n/a				
Parent Element:	SuspiciousActivity				
Element Restriction(s):	Record this element when there is an amount involved in the FinCEN SAR and some or all of the dollar amounts are known. Otherwise, do not record this element and instead, record either the AmountUnknownIndicator element with a "Y" value if the entire amount is unknown, or the NoAmountInvolvedIndicator element with a "Y" value if there is no amount involved in the FinCEN SAR. If some dollar amounts are known while others are unknown, do not record the AmountUnknownIndicator element; instead, record the total of all known amounts in the TotalSuspiciousAmountText element and provide an explanation for the unknown amounts in the narrative.				
Value Restriction(s):	The value provided must adhere to the following requirements: 1-15 numeric characters (without leading zeros) denominated in whole U.S. Dollars.				
Remarks:	The batch submission will be <u>accepted with warnings</u> if any of the following conditions are true: <ul style="list-style-type: none"> • The value recorded contains one or more non-numeric characters. • The element is not recorded or does not contain a value and unknown or no amount involved in not indicated. • The element is recorded with a value and unknown or no amount involved is indicated. 				
Example:	<fc2:TotalSuspiciousAmountText>20000</fc2:TotalSuspiciousAmountText>				

Element Name:	SuspiciousActivityClassification	See <i>SuspiciousActivityClassification Elements (below)</i> for details.
---------------	----------------------------------	---

4.7.1. SuspiciousActivityClassification Elements

Element Name:	SuspiciousActivityClassification	minOccurs:	1	maxOccurs:	99																
Description:	Suspicious activity classification (header). This element is the container for information about the specific type of suspicious activity. The following sub-element is associated with this element: <table border="1" data-bbox="443 1232 1385 1381"> <thead> <tr> <th>Name</th> <th>minOccurs</th> <th>maxOccurs</th> <th>Category</th> </tr> </thead> <tbody> <tr> <td>OtherSuspiciousActivityTypeText</td> <td>0</td> <td>1</td> <td>Simple</td> </tr> <tr> <td>SuspiciousActivitySubtypeID</td> <td>1</td> <td>1</td> <td>Simple</td> </tr> <tr> <td>SuspiciousActivityTypeID</td> <td>1</td> <td>1</td> <td>Simple</td> </tr> </tbody> </table> This element corresponds with the following item(s): <ul style="list-style-type: none"> • 32. Structuring (32a – 32e, 32z) • 33. Terrorist financing (33a, 33z) • 34. Fraud (34a – 34m, 34z) • 35. Gaming activities (35a – 35d, 35z) • 36. Money Laundering (36a – 36m, 36z) • 37. Identification/Documentation (37a – 37f, 37z) • 38. Other suspicious activities (38a – 38s, 38z) • 39. Insurance (39a – 39f, 39z) • 40. Securities/Futures/Options (40a – 40e, 40z) • 41. Mortgage fraud (41a – 41e, 41z) • 42. Cyber event (42a – 42b, 42z) <i>Please refer to Attachment C for additional information regarding the above item(s).</i>					Name	minOccurs	maxOccurs	Category	OtherSuspiciousActivityTypeText	0	1	Simple	SuspiciousActivitySubtypeID	1	1	Simple	SuspiciousActivityTypeID	1	1	Simple
Name	minOccurs	maxOccurs	Category																		
OtherSuspiciousActivityTypeText	0	1	Simple																		
SuspiciousActivitySubtypeID	1	1	Simple																		
SuspiciousActivityTypeID	1	1	Simple																		
Attribute(s)	The following attributes must be recorded for this element: <table border="1" data-bbox="443 1860 1385 1896"> <thead> <tr> <th>Name</th> <th>Description</th> </tr> </thead> <tbody> <tr> <td></td> <td></td> </tr> </tbody> </table>					Name	Description														
Name	Description																				

Element Name:	SuspiciousActivityClassification	minOccurs:	1	maxOccurs:	99
	SeqNum	The value recorded for this attribute must be numeric and unique. It may contain any numeric value up to 19 characters in length.			
Parent Element:	SuspiciousActivity				
Element Restriction(s):	Required. This element must be recorded.				
Value Restriction(s):	n/a				
Remarks:	The batch submission will be <u>rejected</u> if any of the following conditions are true: <ul style="list-style-type: none"> • The element is not recorded. • The element is missing a "SeqNum" attribute. • The element contains a "SeqNum" attribute with a duplicate or invalid value. 				
Example:	<pre><fc2:SuspiciousActivityClassification SeqNum="125"> <fc2:SuspiciousActivitySubtypeID>806</fc2:SuspiciousActivitySubtypeID> <fc2:SuspiciousActivityTypeID>8</fc2:SuspiciousActivityTypeID> </fc2:SuspiciousActivityClassification></pre>				

Element Name:	OtherSuspiciousActivityTypeText	minOccurs:	0	maxOccurs:	1
Description:	Suspicious activity other (description). This element identifies the other description of the suspicious activity in the event that a type/category of activity applies (i.e. Structuring, Terrorist financing, etc.) but none of the subtype options apply. This element corresponds with the following item(s): <ul style="list-style-type: none"> • 32z - 42z. Other description of the suspicious activity subtype <i>Please refer to Attachment C for additional information regarding the above item(s).</i>				
Attribute(s)	n/a				
Parent Element:	SuspiciousActivityClassification				
Element Restriction(s):	Conditionally Required. Record this element when the type of suspicious activity is recorded as "Other" (i.e. <SuspiciousActivitySubtypeID> contains any of the following codes: 1999,3999,4999,5999,6999,7999,8999,9999,10999,11999,12999); otherwise, do not record this element.				
Value Restriction(s):	The value provided must adhere to the following requirements: 50 characters or less				
Remarks:	The batch submission will be <u>accepted with warning</u> if any of the following conditions are true: <ul style="list-style-type: none"> • The element is not recorded or does not contain a value and the subtype of suspicious activity is equal to Other. • The element is recorded with a value but the subtype of suspicious activity is not equal to Other. 				
Example:	<pre><fc2:OtherSuspiciousActivityTypeText>other type of suspicious activity description</fc2:OtherSuspiciousActivityTypeText></pre>				

Element Name:	SuspiciousActivitySubtypeID	minOccurs:	1	maxOccurs:	1
Description:	Suspicious activity subtype (code). This element identifies the suspicious activity subtype, such as the specific type of structuring or specific type of gaming activity. This element corresponds with the <u>subtype</u> options associated with the following item(s): <ul style="list-style-type: none"> • 32. Structuring (32a – 32e, 32z) • 33. Terrorist financing (33a, 33z) • 34. Fraud (34a – 34m, 34z) • 35. Gaming activities (35a – 35d, 35z) • 36. Money Laundering (36a – 36m, 36z) • 37. Identification/Documentation (37a – 37f, 37z) • 38. Other suspicious activities (38a – 38s, 38z) • 39. Insurance (39a – 39f, 39z) • 40. Securities/Futures/Options (40a – 40e, 40z) • 41. Mortgage fraud (41a – 41e, 41z) 				

Element Name:	SuspiciousActivitySubtypeID	minOccurs:	1	maxOccurs:	1																																																		
	<ul style="list-style-type: none"> 42. Cyber event (42a – 42b, 42z) <p><i>Please refer to Attachment C for additional information regarding the above item(s).</i></p>																																																						
Attribute(s)	n/a																																																						
Parent Element:	SuspiciousActivityClassification																																																						
Element Restriction(s):	Required. This element must be recorded.																																																						
Value Restriction(s):	<p>The value provided must adhere to the following requirements:</p> <ul style="list-style-type: none"> Record the subtype code from the lists below to identify the specific suspicious activity subtype for the following: <ul style="list-style-type: none"> Structuring (1) <table border="1" data-bbox="444 604 1422 915"> <thead> <tr> <th>Code</th> <th>Description</th> </tr> </thead> <tbody> <tr> <td>111</td> <td>Alters or cancels transaction to avoid BSA recordkeeping requirement</td> </tr> <tr> <td>112</td> <td>Alters or cancels transaction to avoid CTR requirement</td> </tr> <tr> <td>106</td> <td>Suspicious inquiry by customer regarding BSA reporting or recordkeeping requirements</td> </tr> <tr> <td>113</td> <td>Transaction(s) below BSA recordkeeping threshold</td> </tr> <tr> <td>114</td> <td>Transaction(s) below CTR threshold</td> </tr> <tr> <td>1999</td> <td>Other</td> </tr> </tbody> </table> Terrorist financing (7) <table border="1" data-bbox="444 1012 1422 1136"> <thead> <tr> <th>Code</th> <th>Description</th> </tr> </thead> <tbody> <tr> <td>701</td> <td>Known or suspected terrorist/terrorist organization</td> </tr> <tr> <td>7999</td> <td>Other</td> </tr> </tbody> </table> Fraud (3) <table border="1" data-bbox="444 1232 1422 1835"> <thead> <tr> <th>Code</th> <th>Description</th> </tr> </thead> <tbody> <tr> <td>320</td> <td>ACH</td> </tr> <tr> <td>322</td> <td>Advance fee</td> </tr> <tr> <td>321</td> <td>Business loan</td> </tr> <tr> <td>301</td> <td>Check</td> </tr> <tr> <td>304</td> <td>Consumer Loan</td> </tr> <tr> <td>305</td> <td>Credit/Debit Card</td> </tr> <tr> <td>323</td> <td>Healthcare/Public or private health insurance</td> </tr> <tr> <td>308</td> <td>Mail</td> </tr> <tr> <td>309</td> <td>Mass-marketing</td> </tr> <tr> <td>324</td> <td>Ponzi scheme</td> </tr> <tr> <td>310</td> <td>Pyramid scheme</td> </tr> <tr> <td>325</td> <td>Securities fraud</td> </tr> <tr> <td>312</td> <td>Wire transfer</td> </tr> <tr> <td>3999</td> <td>Other</td> </tr> </tbody> </table> Gaming activities (12) 					Code	Description	111	Alters or cancels transaction to avoid BSA recordkeeping requirement	112	Alters or cancels transaction to avoid CTR requirement	106	Suspicious inquiry by customer regarding BSA reporting or recordkeeping requirements	113	Transaction(s) below BSA recordkeeping threshold	114	Transaction(s) below CTR threshold	1999	Other	Code	Description	701	Known or suspected terrorist/terrorist organization	7999	Other	Code	Description	320	ACH	322	Advance fee	321	Business loan	301	Check	304	Consumer Loan	305	Credit/Debit Card	323	Healthcare/Public or private health insurance	308	Mail	309	Mass-marketing	324	Ponzi scheme	310	Pyramid scheme	325	Securities fraud	312	Wire transfer	3999	Other
Code	Description																																																						
111	Alters or cancels transaction to avoid BSA recordkeeping requirement																																																						
112	Alters or cancels transaction to avoid CTR requirement																																																						
106	Suspicious inquiry by customer regarding BSA reporting or recordkeeping requirements																																																						
113	Transaction(s) below BSA recordkeeping threshold																																																						
114	Transaction(s) below CTR threshold																																																						
1999	Other																																																						
Code	Description																																																						
701	Known or suspected terrorist/terrorist organization																																																						
7999	Other																																																						
Code	Description																																																						
320	ACH																																																						
322	Advance fee																																																						
321	Business loan																																																						
301	Check																																																						
304	Consumer Loan																																																						
305	Credit/Debit Card																																																						
323	Healthcare/Public or private health insurance																																																						
308	Mail																																																						
309	Mass-marketing																																																						
324	Ponzi scheme																																																						
310	Pyramid scheme																																																						
325	Securities fraud																																																						
312	Wire transfer																																																						
3999	Other																																																						

Element Name:	SuspiciousActivitySubtypeID	minOccurs:	1	maxOccurs:	1																													
	<table border="1"> <thead> <tr> <th>Code</th> <th>Description</th> </tr> </thead> <tbody> <tr> <td>1201</td> <td>Chip walking</td> </tr> <tr> <td>1202</td> <td>Minimal gaming with large transactions</td> </tr> <tr> <td>1203</td> <td>Suspicious use of counter checks or markers</td> </tr> <tr> <td>1204</td> <td>Unknown source of chips</td> </tr> <tr> <td>12999</td> <td>Other</td> </tr> </tbody> </table>	Code	Description	1201	Chip walking	1202	Minimal gaming with large transactions	1203	Suspicious use of counter checks or markers	1204	Unknown source of chips	12999	Other																					
Code	Description																																	
1201	Chip walking																																	
1202	Minimal gaming with large transactions																																	
1203	Suspicious use of counter checks or markers																																	
1204	Unknown source of chips																																	
12999	Other																																	
	<ul style="list-style-type: none"> ○ Money Laundering (8) 																																	
	<table border="1"> <thead> <tr> <th>Code</th> <th>Description</th> </tr> </thead> <tbody> <tr> <td>801</td> <td>Exchanges small bills for large bills or vice versa</td> </tr> <tr> <td>824</td> <td>Funnel account</td> </tr> <tr> <td>820</td> <td>Suspicious concerning the physical condition of funds</td> </tr> <tr> <td>821</td> <td>Suspicious concerning the source of funds</td> </tr> <tr> <td>804</td> <td>Suspicious designation of beneficiaries, assignees or joint owners</td> </tr> <tr> <td>805</td> <td>Suspicious EFT/wire transfers</td> </tr> <tr> <td>822</td> <td>Suspicious exchange of currencies</td> </tr> <tr> <td>806</td> <td>Suspicious receipt of government payments/benefits</td> </tr> <tr> <td>807</td> <td>Suspicious use of multiple accounts</td> </tr> <tr> <td>808</td> <td>Suspicious use of noncash monetary instruments</td> </tr> <tr> <td>809</td> <td>Suspicious use of third-party transactions (straw-man)</td> </tr> <tr> <td>823</td> <td>Trade Based Money Laundering/Black Market Peso Exchange</td> </tr> <tr> <td>812</td> <td>Transaction out of pattern for customer(s)</td> </tr> <tr> <td>8999</td> <td>Other</td> </tr> </tbody> </table>	Code	Description	801	Exchanges small bills for large bills or vice versa	824	Funnel account	820	Suspicious concerning the physical condition of funds	821	Suspicious concerning the source of funds	804	Suspicious designation of beneficiaries, assignees or joint owners	805	Suspicious EFT/wire transfers	822	Suspicious exchange of currencies	806	Suspicious receipt of government payments/benefits	807	Suspicious use of multiple accounts	808	Suspicious use of noncash monetary instruments	809	Suspicious use of third-party transactions (straw-man)	823	Trade Based Money Laundering/Black Market Peso Exchange	812	Transaction out of pattern for customer(s)	8999	Other			
Code	Description																																	
801	Exchanges small bills for large bills or vice versa																																	
824	Funnel account																																	
820	Suspicious concerning the physical condition of funds																																	
821	Suspicious concerning the source of funds																																	
804	Suspicious designation of beneficiaries, assignees or joint owners																																	
805	Suspicious EFT/wire transfers																																	
822	Suspicious exchange of currencies																																	
806	Suspicious receipt of government payments/benefits																																	
807	Suspicious use of multiple accounts																																	
808	Suspicious use of noncash monetary instruments																																	
809	Suspicious use of third-party transactions (straw-man)																																	
823	Trade Based Money Laundering/Black Market Peso Exchange																																	
812	Transaction out of pattern for customer(s)																																	
8999	Other																																	
	<ul style="list-style-type: none"> ○ Identification / Documentation (4) 																																	
	<table border="1"> <thead> <tr> <th>Code</th> <th>Description</th> </tr> </thead> <tbody> <tr> <td>401</td> <td>Changes spelling or arrangement of name</td> </tr> <tr> <td>402</td> <td>Multiple individuals with same or similar identities</td> </tr> <tr> <td>403</td> <td>Provided questionable or false documentation</td> </tr> <tr> <td>409</td> <td>Provided questionable or false identification</td> </tr> <tr> <td>404</td> <td>Refused or avoided request for documentation</td> </tr> <tr> <td>405</td> <td>Single individual with multiple identities</td> </tr> <tr> <td>4999</td> <td>Other</td> </tr> </tbody> </table>	Code	Description	401	Changes spelling or arrangement of name	402	Multiple individuals with same or similar identities	403	Provided questionable or false documentation	409	Provided questionable or false identification	404	Refused or avoided request for documentation	405	Single individual with multiple identities	4999	Other																	
Code	Description																																	
401	Changes spelling or arrangement of name																																	
402	Multiple individuals with same or similar identities																																	
403	Provided questionable or false documentation																																	
409	Provided questionable or false identification																																	
404	Refused or avoided request for documentation																																	
405	Single individual with multiple identities																																	
4999	Other																																	
	<ul style="list-style-type: none"> ○ Other suspicious activities (9) 																																	
	<table border="1"> <thead> <tr> <th>Code</th> <th>Description</th> </tr> </thead> <tbody> <tr> <td>920</td> <td>Account takeover</td> </tr> <tr> <td>901</td> <td>Bribery or gratuity</td> </tr> <tr> <td>917</td> <td>Counterfeit Instrument (other)</td> </tr> </tbody> </table>	Code	Description	920	Account takeover	901	Bribery or gratuity	917	Counterfeit Instrument (other)																									
Code	Description																																	
920	Account takeover																																	
901	Bribery or gratuity																																	
917	Counterfeit Instrument (other)																																	

Element Name:	SuspiciousActivitySubtypeID	minOccurs:	1	maxOccurs:	1																		
	<table border="1"> <tr><td>1001</td><td>Appraisal fraud</td></tr> <tr><td>1006</td><td>Foreclosure/Short sale fraud</td></tr> <tr><td>1003</td><td>Loan Modification fraud</td></tr> <tr><td>1007</td><td>Origination fraud</td></tr> <tr><td>10999</td><td>Other</td></tr> </table> <ul style="list-style-type: none"> ○ Cyber event (11) <table border="1"> <thead> <tr><th>Code</th><th>Description</th></tr> </thead> <tbody> <tr><td>1101</td><td>Against financial institution(s)</td></tr> <tr><td>1102</td><td>Against financial institution customer(s)</td></tr> <tr><td>11999</td><td>Other</td></tr> </tbody> </table>	1001	Appraisal fraud	1006	Foreclosure/Short sale fraud	1003	Loan Modification fraud	1007	Origination fraud	10999	Other	Code	Description	1101	Against financial institution(s)	1102	Against financial institution customer(s)	11999	Other				
1001	Appraisal fraud																						
1006	Foreclosure/Short sale fraud																						
1003	Loan Modification fraud																						
1007	Origination fraud																						
10999	Other																						
Code	Description																						
1101	Against financial institution(s)																						
1102	Against financial institution customer(s)																						
11999	Other																						
Remarks:	<p>The batch submission will be <u>rejected</u> if any of the following conditions are true:</p> <ul style="list-style-type: none"> • The element is not recorded. • The element is recorded but without a value (i.e. the value is null). • The element contains a value not equal to one of the approved codes listed above. • The element contains a value that is not appropriate for the type of suspicious activity recorded. • The element contains a value that has already been recorded for the Activity. 																						
Example:	<fc2:SuspiciousActivitySubtypeID>601</fc2:SuspiciousActivitySubtypeID>																						

Element Name:	SuspiciousActivityTypeID	minOccurs:	1	maxOccurs:	1										
Description:	<p>Suspicious activity type (code). This element identifies the type/category of suspicious activity, such as Structuring, Terrorist financing, Fraud, etc. This element corresponds with the following item(s):</p> <ul style="list-style-type: none"> • 32. Structuring • 33. Terrorist financing • 34. Fraud • 35. Gaming activities • 36. Money Laundering • 37. Identification/Documentation • 38. Other suspicious activities • 39. Insurance • 40. Securities/Futures/Options • 41. Mortgage fraud • 42. Cyber event <p><i>Please refer to Attachment C for additional information regarding the above item(s).</i></p>														
Attribute(s)	n/a														
Parent Element:	SuspiciousActivityClassification														
Element Restriction(s):	Required. This element must be recorded.														
Value Restriction(s):	<p>The value provided must adhere to the following requirements:</p> <ul style="list-style-type: none"> • Record the type code from the list below to identify the specific suspicious activity type: <table border="1"> <thead> <tr><th>Code</th><th>Description</th></tr> </thead> <tbody> <tr><td>1</td><td>Structuring</td></tr> <tr><td>7</td><td>Terrorist financing</td></tr> <tr><td>3</td><td>Fraud</td></tr> <tr><td>12</td><td>Gaming activities</td></tr> </tbody> </table>					Code	Description	1	Structuring	7	Terrorist financing	3	Fraud	12	Gaming activities
Code	Description														
1	Structuring														
7	Terrorist financing														
3	Fraud														
12	Gaming activities														

Element Name:	SuspiciousActivityTypeID	minOccurs:	1	maxOccurs:	1														
	<table border="1"> <tr><td>8</td><td>Money Laundering</td></tr> <tr><td>4</td><td>Identification / Documentation</td></tr> <tr><td>9</td><td>Other suspicious activities</td></tr> <tr><td>5</td><td>Insurance</td></tr> <tr><td>6</td><td>Securities/Futures/Options</td></tr> <tr><td>10</td><td>Mortgage fraud</td></tr> <tr><td>11</td><td>Cyber event</td></tr> </table>	8	Money Laundering	4	Identification / Documentation	9	Other suspicious activities	5	Insurance	6	Securities/Futures/Options	10	Mortgage fraud	11	Cyber event				
8	Money Laundering																		
4	Identification / Documentation																		
9	Other suspicious activities																		
5	Insurance																		
6	Securities/Futures/Options																		
10	Mortgage fraud																		
11	Cyber event																		
Remarks:	The batch submission will be rejected if any of the following conditions are true: <ul style="list-style-type: none"> • The element is not recorded. • The element is recorded but without a value (i.e. the value is null). • The element contains a value not equal to one of the approved codes listed above. 																		
Example:	<fc2:SuspiciousActivityTypeID>6</fc2:SuspiciousActivityTypeID>																		

4.8. ActivityIPAddress Elements

Element Name:	ActivityIPAddress	minOccurs:	0	maxOccurs:	99																
Description:	IP Address (header). This element is the container for information about IP address involved in the suspicious activity. An explanation of the IP address must be recorded in the narrative as well. <p>The following sub-element is associated with this element:</p> <table border="1"> <thead> <tr> <th>Name</th> <th>minOccurs</th> <th>maxOccurs</th> <th>Category</th> </tr> </thead> <tbody> <tr> <td>ActivityIPAddressDateText</td> <td>0</td> <td>1</td> <td>Simple</td> </tr> <tr> <td>ActivityIPAddressTimeStampText</td> <td>0</td> <td>1</td> <td>Simple</td> </tr> <tr> <td>IPAddressText</td> <td>1</td> <td>1</td> <td>Simple</td> </tr> </tbody> </table> <p>This element corresponds with the following item(s):</p> <ul style="list-style-type: none"> • 43. IP Address (if available) <ul style="list-style-type: none"> ○ 43a. Date (YYYYMMDD) ○ 43b. Timestamp (UCT) (HH:MM:SS) <p><i>Please refer to Attachment C for additional information regarding the above item(s).</i></p>					Name	minOccurs	maxOccurs	Category	ActivityIPAddressDateText	0	1	Simple	ActivityIPAddressTimeStampText	0	1	Simple	IPAddressText	1	1	Simple
Name	minOccurs	maxOccurs	Category																		
ActivityIPAddressDateText	0	1	Simple																		
ActivityIPAddressTimeStampText	0	1	Simple																		
IPAddressText	1	1	Simple																		
Attribute(s)	The following attributes must be recorded for this element: <table border="1"> <thead> <tr> <th>Name</th> <th>Description</th> </tr> </thead> <tbody> <tr> <td>SeqNum</td> <td>The value recorded for this attribute must be numeric and unique. It may contain any numeric value up to 19 characters in length.</td> </tr> </tbody> </table>					Name	Description	SeqNum	The value recorded for this attribute must be numeric and unique. It may contain any numeric value up to 19 characters in length.												
Name	Description																				
SeqNum	The value recorded for this attribute must be numeric and unique. It may contain any numeric value up to 19 characters in length.																				
Parent Element:	Activity																				
Element Restriction(s):	Record this element when the IP address of the subject’s electronic internet based contact with the financial institution is known; otherwise, do not record this element. If reporting an IP address in connection with a cyber-event, do not record this element; instead, record the IP address within the <CyberEventIndicators> section.																				
Value Restriction(s):	n/a																				
Remarks:	The batch submission will be rejected if any of the following conditions are true: <ul style="list-style-type: none"> • The element is missing a “SeqNum” attribute. • The element contains a “SeqNum” attribute with a duplicate or invalid value. 																				
Example:	<fc2:ActivityIPAddress SeqNum="126"> <fc2:ActivityIPAddressDateText>20171101</fc2:ActivityIPAddressDateText>																				

Element Name:	ActivityIPAddress	minOccurs:	0	maxOccurs:	99
	<pre><fc2:ActivityIPAddressTimeStampText/> <fc2:IPAddressText>166.123.216.61</fc2:IPAddressText> </fc2:ActivityIPAddress></pre>				

Element Name:	ActivityIPAddressDateText	minOccurs:	0	maxOccurs:	1
Description:	<p>IP address (date). This element identifies the date of the activity associated with the reported IP address. This element corresponds with the following item(s):</p> <ul style="list-style-type: none"> 43a. IP Address (Date) <p><i>Please refer to Attachment C for additional information regarding the above item(s).</i></p>				
Attribute(s)	n/a				
Parent Element:	ActivityIPAddress				
Element Restriction(s):	Record this element to identify the date of the first instance of the reported IP Address (if known); otherwise, do not record this element.				
Value Restriction(s):	The value provided must adhere to the following requirements: 8 numeric characters in the format YYYYMMDD where YYYY = year, MM = month, and DD = day. Single digit days or months must be prefaced by a zero.				
Remarks:	<p>The batch submission will be <u>accepted with warning</u> if any of the following conditions are true:</p> <ul style="list-style-type: none"> The value recorded for the element is not in the required format (YYYYMMDD). 				
Example:	<fc2:ActivityIPAddressDateText>20171101</fc2:ActivityIPAddressDateText>				

Element Name:	ActivityIPAddressTimeStampText	minOccurs:	0	maxOccurs:	1
Description:	<p>IP address (timestamp). This element identifies the UTC time of the first instance of the reported IP address. This element corresponds with the following item(s):</p> <ul style="list-style-type: none"> 43b. IP Address (Timestamp) <p><i>Please refer to Attachment C for additional information regarding the above item(s).</i></p>				
Attribute(s)	n/a				
Parent Element:	ActivityIPAddress				
Element Restriction(s):	Record this element to identify the Coordinated Universal Time (UCT) associated with the first instance of the reported IP Address (if known); otherwise, do not record this element.				
Value Restriction(s):	The value provided must adhere to the following requirements: UCT time must be in the format "HH:MM:SS" where HH = hour (00-23), MM = minutes (00-59), and SS = second (00-59). Single digit times must be prefaced by a zero.				
Remarks:	<p>The batch submission will be <u>accepted with warning</u> if any of the following conditions are true:</p> <ul style="list-style-type: none"> The value recorded for the element is not in the required format (HH:MM:SS). 				
Example:	<fc2:ActivityIPAddressTimeStampText>05:13:55</fc2:ActivityIPAddressTimeStampText>				

Element Name:	IPAddressText	minOccurs:	1	maxOccurs:	1
Description:	<p>IP address (text). This element identifies the IP address of the subject's electronic internet based contact with the financial institution. example, this may be the IP address used to log into the institution's online banking page or the IP address used to access an institution's mobile application. This element corresponds with the following item(s):</p> <ul style="list-style-type: none"> 43. IP Address (if available) <p><i>Please refer to Attachment C for additional information regarding the above item(s).</i></p>				
Attribute(s)	n/a				
Parent Element:	ActivityIPAddress				

Element Name:	IPAddressText	minOccurs:	1	maxOccurs:	1
Element Restriction(s):	Required. This element must be recorded if the parent element is recorded.				
Value Restriction(s):	<p>The value provided must adhere to the following requirements: If the IP address is IPv4, use a variation of the format nnn.nnn.nnn.nnn (n = number) with periods between the segments. First set of numbers must be values between 1-255 (inclusive); second, third and fourth set of numbers must be values between 0-255 (inclusive).</p> <p>If the IP address is IPv6, use a variation of the format cccc:cccc:cccc:cccc:cccc:cccc:cccc:cccc (c = character, IPv6 is alphanumeric in some segments) with colons between the segments.</p>				
Remarks:	<p>The batch submission will be <u>accepted with warning</u> if any of the following conditions are true:</p> <ul style="list-style-type: none"> The value recorded for the element is not in the required format (see Value Restrictions for format requirements). 				
Example:	<fc2:IPAddressText>166.123.216.61</fc2:IPAddressText>				

4.9. CyberEventIndicators Elements

Element Name:	CyberEventIndicators	minOccurs:	0	maxOccurs:	99																								
Description:	<p>Cyber Event (header). This element is the container for information about cyber event involved in the suspicious activity. An explanation of the cyber event must be recorded in the narrative as well.</p> <p>The following sub-element is associated with this element:</p> <table border="1"> <thead> <tr> <th>Name</th> <th>minOccurs</th> <th>maxOccurs</th> <th>Category</th> </tr> </thead> <tbody> <tr> <td>CyberEventDateText</td> <td>0</td> <td>1</td> <td>Simple</td> </tr> <tr> <td>CyberEventIndicatorsTypeCode</td> <td>1</td> <td>1</td> <td>Simple</td> </tr> <tr> <td>CyberEventTimeStampText</td> <td>0</td> <td>1</td> <td>Simple</td> </tr> <tr> <td>CyberEventTypeOtherText</td> <td>0</td> <td>1</td> <td>Simple</td> </tr> <tr> <td>EventValueText</td> <td>1</td> <td>1</td> <td>Simple</td> </tr> </tbody> </table> <p>This element corresponds with the following item(s):</p> <ul style="list-style-type: none"> 44. Cyber Event Indicators (44a-j, z) <p><i>Please refer to Attachment C for additional information regarding the above item(s).</i></p>					Name	minOccurs	maxOccurs	Category	CyberEventDateText	0	1	Simple	CyberEventIndicatorsTypeCode	1	1	Simple	CyberEventTimeStampText	0	1	Simple	CyberEventTypeOtherText	0	1	Simple	EventValueText	1	1	Simple
Name	minOccurs	maxOccurs	Category																										
CyberEventDateText	0	1	Simple																										
CyberEventIndicatorsTypeCode	1	1	Simple																										
CyberEventTimeStampText	0	1	Simple																										
CyberEventTypeOtherText	0	1	Simple																										
EventValueText	1	1	Simple																										
Attribute(s)	<p>The following attributes must be recorded for this element:</p> <table border="1"> <thead> <tr> <th>Name</th> <th>Description</th> </tr> </thead> <tbody> <tr> <td>SeqNum</td> <td>The value recorded for this attribute must be numeric and unique. It may contain any numeric value up to 19 characters in length.</td> </tr> </tbody> </table>					Name	Description	SeqNum	The value recorded for this attribute must be numeric and unique. It may contain any numeric value up to 19 characters in length.																				
Name	Description																												
SeqNum	The value recorded for this attribute must be numeric and unique. It may contain any numeric value up to 19 characters in length.																												
Parent Element:	Activity																												
Element Restriction(s):	Record this element when the suspicious activity involves one or more types of cyber events; otherwise, do not record this element.																												
Value Restriction(s):	n/a																												
Remarks:	<p>The batch submission will be <u>rejected</u> if any of the following conditions are true:</p> <ul style="list-style-type: none"> The element is missing a "SeqNum" attribute. The element contains a "SeqNum" attribute with a duplicate or invalid value. 																												
Example:	<pre><fc2:CyberEventIndicators SeqNum="128"> <fc2:CyberEventDateText>20171101</fc2:CyberEventDateText> <fc2:CyberEventIndicatorsTypeCode>1</fc2:CyberEventIndicatorsTypeCode> <fc2:CyberEventTimeStampText>11:05:45</fc2:CyberEventTimeStampText> <fc2:EventValueText>166.123.216.61</fc2:EventValueText> </fc2:CyberEventIndicators></pre>																												

Element Name:	CyberEventDateText	minOccurs:	0	maxOccurs:	1
Description:	<p>Cyber event (date). This element identifies the date of the first instance of the reported cyber event, specifically, when reporting a Command and Control IP address or Suspicious IP Address. This element corresponds with the following item(s):</p> <ul style="list-style-type: none"> • 44a2. Date associated with Command and Control IP Address • 44h2. Date associated with Suspicious IP Address <p><i>Please refer to Attachment C for additional information regarding the above item(s).</i></p>				
Attribute(s)	n/a				
Parent Element:	CyberEventIndicators				
Element Restriction(s):	<p>Record this element to identify the date associated with the following cyber events (if known); otherwise, do not record this element:</p> <ul style="list-style-type: none"> • Command and Control IP Address • Suspicious IP Address 				
Value Restriction(s):	<p>The value provided must adhere to the following requirements: 8 numeric characters in the format YYYYMMDD where YYYY = year, MM = month, and DD = day. Single digit days or months must be prefaced by a zero.</p>				
Remarks:	<p>The batch submission will be <u>rejected</u> if any of the following conditions are true:</p> <ul style="list-style-type: none"> • The element is recorded for a cyber event type that is not applicable to this data (see Element Restrictions for more information). <p>The batch submission will be <u>accepted with warning</u> if any of the following conditions are true:</p> <ul style="list-style-type: none"> • The value recorded for the element is not in the required format (YYYYMMDD). 				
Example:	<fc2:CyberEventDateText>20171101</fc2:CyberEventDateText>				

Element Name:	CyberEventIndicatorsTypeCode	minOccurs:	1	maxOccurs:	1																								
Description:	<p>Cyber event indicator type (code). This element identifies the cyber event indicator type. This element corresponds with the following item(s):</p> <ul style="list-style-type: none"> • 44a-j, z. Cyber Event Indicator <p><i>Please refer to Attachment C for additional information regarding the above item(s).</i></p>																												
Attribute(s)	n/a																												
Parent Element:	CyberEventIndicators																												
Element Restriction(s):	Required. This element must be recorded if the parent element is recorded.																												
Value Restriction(s):	<p>The value provided must adhere to the following requirements:</p> <ul style="list-style-type: none"> • Record the type of cyber event indicator from the list below: <table border="1" data-bbox="443 1354 1133 1837"> <thead> <tr> <th>Code</th> <th>Description</th> </tr> </thead> <tbody> <tr> <td>1</td> <td>Command and control IP address</td> </tr> <tr> <td>2</td> <td>Command and control URL/domain</td> </tr> <tr> <td>3</td> <td>Malware MD5, Malware SHA-1, or Malware SHA-256</td> </tr> <tr> <td>4</td> <td>Media Access Control (MAC) Address</td> </tr> <tr> <td>5</td> <td>Port</td> </tr> <tr> <td>6</td> <td>Suspicious e-mail address</td> </tr> <tr> <td>7</td> <td>Suspicious file name</td> </tr> <tr> <td>8</td> <td>Suspicious IP address</td> </tr> <tr> <td>9</td> <td>Suspicious URL/domain</td> </tr> <tr> <td>10</td> <td>Targeted system</td> </tr> <tr> <td>999</td> <td>Other</td> </tr> </tbody> </table>					Code	Description	1	Command and control IP address	2	Command and control URL/domain	3	Malware MD5, Malware SHA-1, or Malware SHA-256	4	Media Access Control (MAC) Address	5	Port	6	Suspicious e-mail address	7	Suspicious file name	8	Suspicious IP address	9	Suspicious URL/domain	10	Targeted system	999	Other
Code	Description																												
1	Command and control IP address																												
2	Command and control URL/domain																												
3	Malware MD5, Malware SHA-1, or Malware SHA-256																												
4	Media Access Control (MAC) Address																												
5	Port																												
6	Suspicious e-mail address																												
7	Suspicious file name																												
8	Suspicious IP address																												
9	Suspicious URL/domain																												
10	Targeted system																												
999	Other																												

Element Name:	CyberEventIndicatorsTypeCode	minOccurs:	1	maxOccurs:	1
Remarks:	The batch submission will be <u>rejected</u> if any of the following conditions are true: <ul style="list-style-type: none"> The element is not recorded or does not contain a value. The value recorded is invalid. 				
Example:	<fc2:CyberEventIndicatorsTypeCode>1</fc2:CyberEventIndicatorsTypeCode>				

Element Name:	CyberEventTimeStampText	minOccurs:	0	maxOccurs:	1
Description:	Cyber event (timestamp). This element identifies the UTC time of the first instance of the reported cyber event, specifically, when reporting a Command and Control IP address or Suspicious IP Address. This element corresponds with the following item(s): <ul style="list-style-type: none"> 44a2. Timestamp associated with Command and Control IP Address 44h2. Timestamp associated with Suspicious IP Address <i>Please refer to Attachment C for additional information regarding the above item(s).</i>				
Attribute(s)	n/a				
Parent Element:	CyberEventIndicators				
Element Restriction(s):	Record this element to identify the Coordinated Universal Time (UCT) associated with the first instance of the following cyber events (if known); otherwise, do not record this element: <ul style="list-style-type: none"> Command and Control IP Address Suspicious IP Address 				
Value Restriction(s):	The value provided must adhere to the following requirements: UCT time must be in the format "HH:MM:SS" where HH = hour (00-23), MM = minutes (00-59), and SS = second (00-59). Single digit times must be prefaced by a zero.				
Remarks:	The batch submission will be <u>rejected</u> if any of the following conditions are true: <ul style="list-style-type: none"> The element is recorded for a cyber event type that is not applicable to this data (see Element Restrictions for more information). The batch submission will be <u>accepted with warning</u> if any of the following conditions are true: <ul style="list-style-type: none"> The value recorded for the element is not in the required format (HH:MM:SS). 				
Example:	<fc2:CyberEventTimeStampText>11:05:45</fc2:CyberEventTimeStampText>				

Element Name:	CyberEventTypeOtherText	minOccurs:	0	maxOccurs:	1
Description:	Cyber event other (description). This element identifies the description of the other type of reported cyber event. This element corresponds with the following item(s): <ul style="list-style-type: none"> 44z2. Text description of other value <i>Please refer to Attachment C for additional information regarding the above item(s).</i>				
Attribute(s)	n/a				
Parent Element:	CyberEventIndicators				
Element Restriction(s):	Conditionally Required. Record this element when the type of cyber event is recorded as "Other" (i.e. <CyberEventIndicatorsTypeCode> contains the value "11" code); otherwise, do not record this element.				
Value Restriction(s):	The value provided must adhere to the following requirements: 50 characters or less				
Remarks:	The batch submission will be <u>accepted with warnings</u> if any of the following conditions are true: <ul style="list-style-type: none"> The element is not recorded or does not contain a value and the <CyberEventIndicatorsTypeCode> is equal to "11" Other. The element is recorded with a value and the <CyberEventIndicatorsTypeCode> is not equal to "11" Other. 				
Example:	<fc2:CyberEventTypeOtherText>Other description</fc2:CyberEventTypeOtherText>				

Element Name:	EventValueText	minOccurs:	1	maxOccurs:	1
Description:	<p>Cyber event (value). This element identifies the event value associated with the reported cyber event. This element corresponds with the following item(s):</p> <ul style="list-style-type: none"> 44a-j, z. Cyber Event Indicator <p><i>Please refer to Attachment C for additional information regarding the above item(s).</i></p>				
Attribute(s)	n/a				
Parent Element:	CyberEventIndicators				
Element Restriction(s):	Required. This element must be recorded if the parent element is recorded.				
Value Restriction(s):	<p>The value provided must adhere to the following requirements: 4000 characters or less; must be in the following format based on these specific types of cyber events:</p> <ul style="list-style-type: none"> Command and Control/Suspicious IP Addresses: If the IP address is IPv4, use a variation of the format nnn.nnn.nnn.nnn (n = number) with periods between the segments. First set of numbers must be values between 1-255 (inclusive); second, third and fourth set of numbers must be values between 0-255 (inclusive). If the IP address is IPv6, use a variation of the format cccc:cccc:cccc:cccc:cccc:cccc:cccc:cccc (c = character, IPv6 is alphanumeric in some segments) with colons between the segments. URL/Domain names: Must contain at least one period, no spaces, cannot begin or end with a dash. Media Access Control (MAC) Addresses: Must be in the format XX:XX:XX:XX:XX:XX Email Addresses: Must contain @ symbol and at least one period following the @ symbol. 				
Remarks:	<p>The batch submission will be <u>accepted with warnings</u> if any of the following conditions are true:</p> <ul style="list-style-type: none"> The element is not recorded or does not contain. The value recorded is not valid based on the type of cyber event (see Value Restrictions for format requirements). 				
Example:	<fc2:EventValueText>166.123.216.61</fc2:EventValueText>				

4.10. Assets Elements

Element Name:	Assets	minOccurs:	0	maxOccurs:	31																
Description:	<p>Asset (header). This element is the container for information about asset involved in the suspicious activity, specifically the product type, instrument type, and/or payment mechanism.</p> <p>The following sub-elements are associated with this element:</p> <table border="1"> <thead> <tr> <th>Name</th> <th>minOccurs</th> <th>maxOccurs</th> <th>Category</th> </tr> </thead> <tbody> <tr> <td>AssetSubtypeID (Items 45a-t, z / 46a-i, z)</td> <td>1</td> <td>1</td> <td>Simple</td> </tr> <tr> <td>AssetTypeID (Items 45, 46)</td> <td>1</td> <td>1</td> <td>Simple</td> </tr> <tr> <td>OtherAssetSubtypeText (Items 45z, 46z)</td> <td>0</td> <td>1</td> <td>Simple</td> </tr> </tbody> </table> <p>This element corresponds with the following item(s):</p> <ul style="list-style-type: none"> 45. Product type(s) involved in suspicious activity (45a-t, z) 46. Instrument type(s)/payment mechanism(s) involved in suspicious activity (46a-I, z) <p><i>Please refer to Attachment C for additional information regarding the above item(s).</i></p>					Name	minOccurs	maxOccurs	Category	AssetSubtypeID (Items 45a-t, z / 46a-i, z)	1	1	Simple	AssetTypeID (Items 45, 46)	1	1	Simple	OtherAssetSubtypeText (Items 45z, 46z)	0	1	Simple
Name	minOccurs	maxOccurs	Category																		
AssetSubtypeID (Items 45a-t, z / 46a-i, z)	1	1	Simple																		
AssetTypeID (Items 45, 46)	1	1	Simple																		
OtherAssetSubtypeText (Items 45z, 46z)	0	1	Simple																		
Attribute(s)	<p>The following attributes must be recorded for this element:</p> <table border="1"> <thead> <tr> <th>Name</th> <th>Description</th> </tr> </thead> <tbody> <tr> <td>SeqNum</td> <td>The value recorded for this attribute must be numeric and unique. It may contain any numeric value up to 19 characters in length.</td> </tr> </tbody> </table>					Name	Description	SeqNum	The value recorded for this attribute must be numeric and unique. It may contain any numeric value up to 19 characters in length.												
Name	Description																				
SeqNum	The value recorded for this attribute must be numeric and unique. It may contain any numeric value up to 19 characters in length.																				
Parent Element:	Activity																				
Element Restriction(s):	Record this element when a product type, instrument type, and/or payment mechanism, was involved in the suspicious activity; otherwise, do not record this element.																				

Element Name:	Assets	minOccurs:	0	maxOccurs:	31								
	<p>If multiple product/instrument types and/or payment mechanisms were involved in the suspicious activity, record a separate instance of this element to identify each one that applies. The following table describes the min/max number of occurrences this element may be recorded for item 45 (product type) and item 46 (instrument type/payment mechanism):</p> <table border="1"> <thead> <tr> <th>Sub-types associated with the following types:</th> <th>min-max</th> </tr> </thead> <tbody> <tr> <td>Item 45. Product type (AssetTypeID=5)</td> <td>0-21</td> </tr> <tr> <td>Item 46. Instrument type/Payment mechanism (AssetTypeID=6)</td> <td>0-10</td> </tr> <tr> <td style="text-align: right;">Total</td> <td>0-31</td> </tr> </tbody> </table>					Sub-types associated with the following types:	min-max	Item 45. Product type (AssetTypeID=5)	0-21	Item 46. Instrument type/Payment mechanism (AssetTypeID=6)	0-10	Total	0-31
Sub-types associated with the following types:	min-max												
Item 45. Product type (AssetTypeID=5)	0-21												
Item 46. Instrument type/Payment mechanism (AssetTypeID=6)	0-10												
Total	0-31												
Value Restriction(s):	n/a												
Remarks:	<p>The batch submission will be <u>rejected</u> if any of the following conditions are true:</p> <ul style="list-style-type: none"> The element is missing a "SeqNum" attribute. The element contains a "SeqNum" attribute with a duplicate or invalid value. 												
Example:	<pre><fc2:Assets SeqNum="130"> <fc2:AssetSubTypeID>2</fc2:AssetSubTypeID> <fc2:AssetTypeID>5</fc2:AssetTypeID> </fc2:Assets></pre>												

Element Name:	AssetSubTypeID	minOccurs:	1	maxOccurs:	1																												
Description:	<p>Asset subtype (code). This element identifies the specific type of asset involved in the suspicious activity, such as Bonds/Notes if a product type is involved, or Bank/cashier's check if an instrument/payment mechanism is involved. This element corresponds with the following item(s):</p> <ul style="list-style-type: none"> 45a-t, z. Product type(s) involved in suspicious activity 46a-i, z. Instrument type(s)/payment mechanism(s) involved in suspicious activity <p><i>Please refer to Attachment C for additional information regarding the above item(s).</i></p>																																
Attribute(s)	n/a																																
Parent Element:	Assets																																
Element Restriction(s):	Required. This element must be recorded if the parent element is recorded.																																
Value Restriction(s):	<p>The value provided must adhere to the following requirements:</p> <ul style="list-style-type: none"> Item 45. Product type (AssetTypeID=5) <table border="1"> <thead> <tr> <th>Code</th> <th>Description</th> </tr> </thead> <tbody> <tr><td>2</td><td>Bonds/Notes</td></tr> <tr><td>3</td><td>Commercial mortgage</td></tr> <tr><td>4</td><td>Commercial paper</td></tr> <tr><td>5</td><td>Credit card</td></tr> <tr><td>6</td><td>Debit card</td></tr> <tr><td>46</td><td>Deposit Account</td></tr> <tr><td>7</td><td>Forex transactions</td></tr> <tr><td>8</td><td>Futures/Options on futures</td></tr> <tr><td>9</td><td>Hedge fund</td></tr> <tr><td>11</td><td>Home equity line of credit</td></tr> <tr><td>10</td><td>Home equity loan</td></tr> <tr><td>12</td><td>Insurance/Annuity products</td></tr> <tr><td>47</td><td>Microcap securities</td></tr> </tbody> </table>					Code	Description	2	Bonds/Notes	3	Commercial mortgage	4	Commercial paper	5	Credit card	6	Debit card	46	Deposit Account	7	Forex transactions	8	Futures/Options on futures	9	Hedge fund	11	Home equity line of credit	10	Home equity loan	12	Insurance/Annuity products	47	Microcap securities
Code	Description																																
2	Bonds/Notes																																
3	Commercial mortgage																																
4	Commercial paper																																
5	Credit card																																
6	Debit card																																
46	Deposit Account																																
7	Forex transactions																																
8	Futures/Options on futures																																
9	Hedge fund																																
11	Home equity line of credit																																
10	Home equity loan																																
12	Insurance/Annuity products																																
47	Microcap securities																																

Element Name:	AssetSubtypeID	minOccurs:	1	maxOccurs:	1																																					
	<table border="1"> <tr><td>13</td><td>Mutual fund</td></tr> <tr><td>14</td><td>Options on securities</td></tr> <tr><td>16</td><td>Prepaid access</td></tr> <tr><td>17</td><td>Residential mortgage</td></tr> <tr><td>18</td><td>Security futures products</td></tr> <tr><td>19</td><td>Stocks</td></tr> <tr><td>20</td><td>Swap, hybrid, or other derivative</td></tr> <tr><td>30</td><td>Other</td></tr> </table> <ul style="list-style-type: none"> Item 46. Instrument type/Payment mechanism (AssetTypeID=6) <table border="1"> <thead> <tr> <th>Code</th> <th>Description</th> </tr> </thead> <tbody> <tr><td>31</td><td>Bank/Cashier's check</td></tr> <tr><td>32</td><td>Foreign currency</td></tr> <tr><td>33</td><td>Funds transfer</td></tr> <tr><td>34</td><td>Gaming instruments</td></tr> <tr><td>35</td><td>Government payment</td></tr> <tr><td>36</td><td>Money orders</td></tr> <tr><td>37</td><td>Personal/Business check</td></tr> <tr><td>38</td><td>Travelers checks</td></tr> <tr><td>39</td><td>U.S. Currency</td></tr> <tr><td>41</td><td>Other</td></tr> </tbody> </table>	13	Mutual fund	14	Options on securities	16	Prepaid access	17	Residential mortgage	18	Security futures products	19	Stocks	20	Swap, hybrid, or other derivative	30	Other	Code	Description	31	Bank/Cashier's check	32	Foreign currency	33	Funds transfer	34	Gaming instruments	35	Government payment	36	Money orders	37	Personal/Business check	38	Travelers checks	39	U.S. Currency	41	Other			
13	Mutual fund																																									
14	Options on securities																																									
16	Prepaid access																																									
17	Residential mortgage																																									
18	Security futures products																																									
19	Stocks																																									
20	Swap, hybrid, or other derivative																																									
30	Other																																									
Code	Description																																									
31	Bank/Cashier's check																																									
32	Foreign currency																																									
33	Funds transfer																																									
34	Gaming instruments																																									
35	Government payment																																									
36	Money orders																																									
37	Personal/Business check																																									
38	Travelers checks																																									
39	U.S. Currency																																									
41	Other																																									
Remarks:	The batch submission will be <u>rejected</u> if any of the following conditions are true: <ul style="list-style-type: none"> The element is not recorded. The element is recorded but without a value (i.e. the value is null). The element contains a value not equal to one of the approved codes listed above. The element contains a value that is not appropriate for the type of asset recorded. The element contains a value that has already been recorded for the Activity. 																																									
Example:	<fc2:AssetSubtypeID>2</fc2:AssetSubtypeID>																																									

Element Name:	AssetTypeID	minOccurs:	1	maxOccurs:	1						
Description:	Asset type (code). This element identifies the type/category of assets, specifically whether it is associated with a product type or instrument/payment mechanism. This element corresponds with the following item(s): <ul style="list-style-type: none"> 45. Product type(s) involved in suspicious activity 46. Instrument type(s)/payment mechanism(s) involved in suspicious activity <i>Please refer to Attachment C for additional information regarding the above item(s).</i>										
Attribute(s)	n/a										
Parent Element:	Assets										
Element Restriction(s):	Required. This element must be recorded if the parent element is recorded.										
Value Restriction(s):	The value provided must adhere to the following requirements: <table border="1"> <thead> <tr> <th>Code</th> <th>Description</th> </tr> </thead> <tbody> <tr> <td>5</td> <td>Product type(s) involved in suspicious activity</td> </tr> <tr> <td>6</td> <td>Instrument type(s)/payment mechanism(s) involved in suspicious activity</td> </tr> </tbody> </table>					Code	Description	5	Product type(s) involved in suspicious activity	6	Instrument type(s)/payment mechanism(s) involved in suspicious activity
Code	Description										
5	Product type(s) involved in suspicious activity										
6	Instrument type(s)/payment mechanism(s) involved in suspicious activity										

Element Name:	AssetTypeID	minOccurs:	1	maxOccurs:	1
Remarks:	The batch submission will be rejected if any of the following conditions are true: <ul style="list-style-type: none"> The element is not recorded. The element is recorded but without a value (i.e. the value is null). The element contains a value not equal to one of the approved codes listed above. 				
Example:	<fc2:AssetTypeID>5</fc2:AssetTypeID>				

Element Name:	OtherAssetSubtypeText	minOccurs:	0	maxOccurs:	1
Description:	Asset other (description). This element identifies the description of the other type of reported asset subtype. This element corresponds with the following item(s): <ul style="list-style-type: none"> 45z. Product type(s) (other description) 46z. Instrument type(s)/payment mechanism(s) (other description) Please refer to Attachment C for additional information regarding the above item(s).				
Attribute(s)	n/a				
Parent Element:	Assets				
Element Restriction(s):	Conditionally Required. Record this element to provide a description of the other product/instrument type/payment mechanism when the <AssetSubtypeID> element contains the values "30" or "41"; otherwise, do not record this element.				
Value Restriction(s):	The value provided must adhere to the following requirements: 50 characters or less.				
Remarks:	The batch submission will be accepted with warnings if any of the following conditions are true: <ul style="list-style-type: none"> The element is not recorded or does not contain a value and Other is indicated for the <AssetSubtypeID> element. The element is recorded with a value and Other is not indicated for the <AssetSubtypeID> element. 				
Example:	<fc2:OtherAssetSubtypeText>other instrument type description</fc2:OtherAssetSubtypeText>				

4.11. AssetsAttribute Elements

Element Name:	AssetsAttribute	minOccurs:	0	maxOccurs:	396												
Description:	Asset Attribute (header). This element is the container for information about the asset attribute involved in the suspicious activity, whether it be a type of commodity, product/instrument, market where traded, and/or CUSIP number. <p>The following sub-elements are associated with this element:</p> <table border="1"> <thead> <tr> <th>Name</th> <th>minOccurs</th> <th>maxOccurs</th> <th>Category</th> </tr> </thead> <tbody> <tr> <td>AssetAttributeDescriptionText (Items 47-50)</td> <td>1</td> <td>1</td> <td>Simple</td> </tr> <tr> <td>AssetAttributeTypeID (Items 47-50)</td> <td>1</td> <td>1</td> <td>Simple</td> </tr> </tbody> </table> This element corresponds with the following item(s): <ul style="list-style-type: none"> 47. Commodity type (if applicable) 48. Product/Instrument description (if needed) 49. Market where traded 50. CUSIP number Please refer to Attachment C for additional information regarding the above item(s).					Name	minOccurs	maxOccurs	Category	AssetAttributeDescriptionText (Items 47-50)	1	1	Simple	AssetAttributeTypeID (Items 47-50)	1	1	Simple
Name	minOccurs	maxOccurs	Category														
AssetAttributeDescriptionText (Items 47-50)	1	1	Simple														
AssetAttributeTypeID (Items 47-50)	1	1	Simple														
Attribute(s)	The following attributes must be recorded for this element: <table border="1"> <thead> <tr> <th>Name</th> <th>Description</th> </tr> </thead> <tbody> <tr> <td></td> <td></td> </tr> </tbody> </table>					Name	Description										
Name	Description																

Element Name:	AssetsAttribute	minOccurs:	0	maxOccurs:	396												
	SeqNum	The value recorded for this attribute must be numeric and unique. It may contain any numeric value up to 19 characters in length.															
Parent Element:	Activity																
Element Restriction(s):	<p>Record this element when the suspicious activity involves any of the following: Commodity type, product/instrument, market where traded, and/or CUSIP number; otherwise, do not record this element.</p> <p>No more than 99 occurrences of each asset attribute type mentioned above may be recorded for the FinCEN SAR:</p> <table border="1"> <thead> <tr> <th>Attribute types</th> <th>min-max</th> </tr> </thead> <tbody> <tr> <td>Item 47. Commodity type (if applicable)</td> <td>0-99</td> </tr> <tr> <td>Item 48. Product/Instrument description (if needed)</td> <td>0-99</td> </tr> <tr> <td>Item 49. Market where traded</td> <td>0-99</td> </tr> <tr> <td>Item 50. CUSIP number</td> <td>0-99</td> </tr> <tr> <td style="text-align: right;">Total</td> <td>0-396</td> </tr> </tbody> </table>					Attribute types	min-max	Item 47. Commodity type (if applicable)	0-99	Item 48. Product/Instrument description (if needed)	0-99	Item 49. Market where traded	0-99	Item 50. CUSIP number	0-99	Total	0-396
Attribute types	min-max																
Item 47. Commodity type (if applicable)	0-99																
Item 48. Product/Instrument description (if needed)	0-99																
Item 49. Market where traded	0-99																
Item 50. CUSIP number	0-99																
Total	0-396																
Value Restriction(s):	n/a																
Remarks:	<p>The batch submission will be <u>rejected</u> if any of the following conditions are true:</p> <ul style="list-style-type: none"> The element is missing a "SeqNum" attribute. The element contains a "SeqNum" attribute with a duplicate or invalid value. 																
Example:	<pre><fc2:AssetsAttribute SeqNum="134"> <fc2:AssetAttributeDescriptionText>Commodity type description</fc2:AssetAttributeDescriptionText> <fc2:AssetAttributeTypeID>2</fc2:AssetAttributeTypeID> </fc2:AssetsAttribute></pre>																

Element Name:	AssetAttributeDescriptionText	minOccurs:	1	maxOccurs:	1
Description:	<p>Asset attribute other (description). This element provides a description of the reported asset attribute involved in the suspicious activity. This element corresponds with the following item(s):</p> <ul style="list-style-type: none"> 47. Commodity type (if applicable) 48. Product/Instrument description (if needed) 49. Market where traded 50. CUSIP number <p><i>Please refer to Attachment C for additional information regarding the above item(s).</i></p>				
Attribute(s)	n/a				
Parent Element:	AssetsAttribute				
Element Restriction(s):	Required. This element must be recorded if the parent element is recorded.				
Value Restriction(s):	<p>The value provided must adhere to the following requirements:</p> <ul style="list-style-type: none"> Commodity type description: 50 characters or less Instrument/Product description: 50 characters or less Market where traded: 3-5 letter code for the market where a recorded commodity was traded. Use only the ISO 10383 Exchange/Market Identifier Codes (MIC) found at http://www.iso15022.org/MIC/homepageMIC.htm. CUSIP Number: 12 characters or less to identify the CUSIP number of a recorded securities product (such as stocks and bonds) involved in the suspicious. 				
Remarks:	<p>The batch submission will be <u>accepted with warnings</u> if any of the following conditions are true:</p> <ul style="list-style-type: none"> The element is not recorded or the element is recorded but with no value. The value recorded is not valid based on the type of asset attribute (see Value Restrictions for format requirements). 				

Element Name:	AssetAttributeDescriptionText	minOccurs:	1	maxOccurs:	1
Example:	<fc2:AssetAttributeDescriptionText>Commodity type description</fc2:AssetAttributeDescriptionText>				

Element Name:	AssetAttributeTypeID	minOccurs:	1	maxOccurs:	1										
Description:	<p>Asset attribute type (code). This element identifies the type/category of asset attribute, specifically whether it is a type of commodity, product/instrument, market where traded, or CUSIP number. This element corresponds with the following item(s):</p> <ul style="list-style-type: none"> • 47. Commodity type (if applicable) • 48. Product/Instrument description (if needed) • 49. Market where traded • 50. CUSIP number <p><i>Please refer to Attachment C for additional information regarding the above item(s).</i></p>														
Attribute(s)	n/a														
Parent Element:	AssetsAttribute														
Element Restriction(s):	Required. This element must be recorded if the parent element is recorded.														
Value Restriction(s):	<p>The value provided must adhere to the following requirements:</p> <table border="1"> <thead> <tr> <th>Code</th> <th>Description</th> </tr> </thead> <tbody> <tr> <td>2</td> <td>Commodity type</td> </tr> <tr> <td>3</td> <td>Product/Instrument type</td> </tr> <tr> <td>4</td> <td>Market where traded</td> </tr> <tr> <td>1</td> <td>CUSIP number</td> </tr> </tbody> </table>					Code	Description	2	Commodity type	3	Product/Instrument type	4	Market where traded	1	CUSIP number
Code	Description														
2	Commodity type														
3	Product/Instrument type														
4	Market where traded														
1	CUSIP number														
Remarks:	<p>The batch submission will be <u>rejected</u> if any of the following conditions are true:</p> <ul style="list-style-type: none"> • The element is not recorded. • The element is recorded but without a value (i.e. the value is null). • The element contains a value not equal to one of the approved codes listed above. 														
Example:	<fc2:AssetAttributeTypeID>2</fc2:AssetAttributeTypeID>														

4.12. ActivityNarrativeInformation Elements

Element Name:	ActivityNarrativeInformation	minOccurs:	1	maxOccurs:	5												
Description:	<p>Narrative (header). This element is the container for information about narrative description associated with the FinCEN SAR.</p> <p>The following sub-elements are associated with this element:</p> <table border="1"> <thead> <tr> <th>Name</th> <th>minOccurs</th> <th>maxOccurs</th> <th>Category</th> </tr> </thead> <tbody> <tr> <td>ActivityNarrativeSequenceNumber</td> <td>1</td> <td>1</td> <td>Simple</td> </tr> <tr> <td>ActivityNarrativeText</td> <td>1</td> <td>1</td> <td>Simple</td> </tr> </tbody> </table> <p>This element corresponds with the following item(s):</p> <ul style="list-style-type: none"> ○ Part V. Suspicious Activity Report – Narrative <p><i>Please refer to Attachment C for additional information regarding the above item(s).</i></p>					Name	minOccurs	maxOccurs	Category	ActivityNarrativeSequenceNumber	1	1	Simple	ActivityNarrativeText	1	1	Simple
Name	minOccurs	maxOccurs	Category														
ActivityNarrativeSequenceNumber	1	1	Simple														
ActivityNarrativeText	1	1	Simple														
Attribute(s)	<p>The following attributes must be recorded for this element:</p> <table border="1"> <thead> <tr> <th>Name</th> <th>Description</th> </tr> </thead> <tbody> <tr> <td>SeqNum</td> <td>The value recorded for this attribute must be numeric and unique. It may contain any numeric value up to 19 characters in length.</td> </tr> </tbody> </table>					Name	Description	SeqNum	The value recorded for this attribute must be numeric and unique. It may contain any numeric value up to 19 characters in length.								
Name	Description																
SeqNum	The value recorded for this attribute must be numeric and unique. It may contain any numeric value up to 19 characters in length.																
Parent Element:	Activity																

Element Name:	ActivityNarrativeInformation	minOccurs:	1	maxOccurs:	5
Element Restriction(s):	Required. This element must be recorded.				
Value Restriction(s):	n/a				
Remarks:	The batch submission will be <u>rejected</u> if any of the following conditions are true: <ul style="list-style-type: none"> • The element is not recorded. • The element is missing a "SeqNum" attribute. • The element contains a "SeqNum" attribute with a duplicate or invalid value. 				
Example:	<pre><fc2:ActivityNarrativeInformation SeqNum="136"> <fc2:ActivityNarrativeSequenceNumber>1</fc2:ActivityNarrativeSequenceNumber> <fc2:ActivityNarrativeText>Text narrative text</fc2:ActivityNarrativeText> </fc2:ActivityNarrativeInformation></pre>				

Element Name:	ActivityNarrativeSequenceNumber	minOccurs:	1	maxOccurs:	1												
Description:	Narrative (sequence number). This element identifies the sequence in which the narrative text should be constructed in the event that multiple ActivityNarrativeInformation element blocks are needed to record the entire narrative. For example, if the narrative text is 5,000 characters in length, there should be two instances of the ActivityNarrativeInformation element block, where the first instance contains ActivityNarrativeSequenceNumber ">1<" followed by the first 4,000 characters of the narrative description in the ActivityNarrativeText element; in order to record the remaining 1,000 characters of the narrative description, a second instance of the ActivityNarrativeInformation element block should be recorded where the ActivityNarrativeSequenceNumber is ">2<" followed by the remaining 1,000 characters of the narrative description in the ActivityNarrativeText element.																
Attribute(s)	n/a																
Parent Element:	ActivityNarrativeInformation																
Element Restriction(s):	Required. This element must be recorded when the parent element is recorded.																
Value Restriction(s):	The value provided must adhere to the following requirements: <table border="1" data-bbox="443 1136 1300 1381"> <thead> <tr> <th>Code</th> <th>Description</th> </tr> </thead> <tbody> <tr> <td>1</td> <td>First block of narrative text (character set 1-4000)</td> </tr> <tr> <td>2</td> <td>Second block of narrative text (character set 4001-8000, if needed)</td> </tr> <tr> <td>3</td> <td>Third block of narrative text (character set 8001-12000, if needed)</td> </tr> <tr> <td>4</td> <td>Fourth block of narrative text (character set 12001-16000, if needed)</td> </tr> <tr> <td>5</td> <td>Fifth block of narrative text (character set 16001-20000, if needed)</td> </tr> </tbody> </table>					Code	Description	1	First block of narrative text (character set 1-4000)	2	Second block of narrative text (character set 4001-8000, if needed)	3	Third block of narrative text (character set 8001-12000, if needed)	4	Fourth block of narrative text (character set 12001-16000, if needed)	5	Fifth block of narrative text (character set 16001-20000, if needed)
Code	Description																
1	First block of narrative text (character set 1-4000)																
2	Second block of narrative text (character set 4001-8000, if needed)																
3	Third block of narrative text (character set 8001-12000, if needed)																
4	Fourth block of narrative text (character set 12001-16000, if needed)																
5	Fifth block of narrative text (character set 16001-20000, if needed)																
Remarks:	The batch submission will be <u>rejected</u> if any of the following conditions are true: <ul style="list-style-type: none"> • The element is not recorded or does not contain a value. • The value recorded is not equal to a valid code. • The element contains a value that has already been recorded for the Activity. 																
Example:	<pre><fc2:ActivityNarrativeSequenceNumber>1</fc2:ActivityNarrativeSequenceNumber></pre>																

Element Name:	ActivityNarrativeText	minOccurs:	1	maxOccurs:	1
Description:	Narrative (description). This element records the narrative description associated with the suspicious activity. The narrative must provide a clear, complete, and concise description of the activity, including what was unusual or irregular that caused suspicion. This description should include data from Parts I through III only when that data are necessary for a complete understanding of the suspicious activity. Filers should include any other information necessary to explain the nature and circumstances of the suspicious activity				
Attribute(s)	n/a				

Element Name:	ActivityNarrativeText	minOccurs:	1	maxOccurs:	1
Parent Element:	ActivityNarrativeInformation				
Element Restriction(s):	Required. This element must be recorded when the parent element is recorded.				
Value Restriction(s):	The value provided must adhere to the following requirements: 4000 characters or less				
Remarks:	The batch submission will be <u>rejected</u> if any of the following conditions are true: <ul style="list-style-type: none"> The element is not recorded or does not contain a value. 				
Example:	<fc2:ActivityNarrativeText>Text narrative text</fc2:ActivityNarrativeText>				

5. Party Elements by Party Type

The <Party> element is comprised of various elements and sub-elements that apply to specific party types (i.e. Transmitter, financial institution where activity occurred, etc.). The chart below describes at a high level the party elements that apply to each party type.

Activity party type code definitions										
35 = Transmitter 37 = Transmitter Contact 30 = Filing Institution 8 = Contact Office 18 = LE Contact Agency										
19 = LE Contact Name 34 = Financial Institution Where Activity Occurred										
46 = Branch Where Activity Occurred 33 = Subject 41 = Financial Institution Where Account is Held										
Element name	35	37	30	8	18	19	34	46	33	41
<Party SeqNum="">	•	•	•	•	•	•	•		•	
<ActivityPartyTypeCode/>	•	•	•	•	•	•	•		•	
<AdmissionConfessionNoIndicator/>									•	
<AdmissionConfessionYesIndicator/>									•	
<AllCriticalSubjectInformationUnavailableIndicator/>									•	
<BirthDateUnknownIndicator/>									•	
<BothPurchaserSenderPayeeReceiveIndicator/>									•	
<ContactDateText/>						•				
<FemaleGenderIndicator/>									•	
<IndividualBirthDateText/>									•	
<LossToFinancialAmountText/>							•			
<MaleGenderIndicator/>									•	
<NoBranchActivityInvolvedIndicator/>							•			
<NoKnownAccountInvolvedIndicator/>									•	
<NonUSFinancialInstitutionIndicator/>									•	
<PartyAsEntityOrganizationIndicator/>									•	
<PayeeReceiverIndicator/>									•	
<PayLocationIndicator/>							•			
<PrimaryRegulatorTypeCode/>			•				•			
<PurchaserSenderIndicator/>									•	
<SellingLocationIndicator/>							•			
<SellingPayingLocationIndicator/>							•			
<UnknownGenderIndicator/>									•	
<PartyName SeqNum="">	•	•	•	•	•	•	•		•	
<EntityLastNameUnknownIndicator/>							•		•	
<FirstNameUnknownIndicator/>									•	
<PartyNameTypeCode/>	•	•	•	•	•	•	•		•	
<RawEntityIndividualLastName/>									•	
<RawIndividualFirstName/>									•	
<RawIndividualMiddleName/>									•	
<RawIndividualNameSuffixText/>									•	
<RawPartyFullName/>	•	•	•	•	•	•	•		•	
</PartyName>	•	•	•	•	•	•	•		•	
<Address SeqNum="">	•		•				•		•	
<CityUnknownIndicator/>							•		•	
<CountryCodeUnknownIndicator/>							•		•	
<RawCityText/>	•		•				•		•	
<RawCountryCodeText/>	•		•				•		•	
<RawStateCodeText/>	•		•				•		•	
<RawStreetAddress1Text/>	•		•				•		•	
<RawZIPCode/>	•		•				•		•	
<StateCodeUnknownIndicator/>									•	
<StreetAddressUnknownIndicator/>							•		•	
<ZIPCodeUnknownIndicator/>							•		•	
</Address>	•		•				•		•	

Element name	35	37	30	8	18	19	34	46	33	41
<PhoneNumber SeqNum="">	•			•		•			•	
<PhoneNumberExtensionText/>				•		•			•	
<PhoneNumberText/>	•			•		•			•	
<PhoneNumberTypeCode/>									•	
</PhoneNumber>	•			•		•			•	
<PartyIdentification SeqNum="">	•		•				•		•	
<IdentificationPresentUnknownIndicator/>									•	
<OtherIssuerCountryText/>									•	
<OtherIssuerStateText/>									•	
<OtherPartyIdentificationTypeText/>									•	
<PartyIdentificationNumberText/>	•		•				•		•	
<PartyIdentificationTypeCode/>	•		•				•		•	
<TINUnknownIndicator/>							•		•	
</PartyIdentification>	•		•				•		•	
<OrganizationClassificationTypeSubtype SeqNum="">			•				•			
<OrganizationSubtypeID/>			•				•			
<OrganizationTypeID/>			•				•			
<OtherOrganizationSubTypeText/>			•				•			
<OtherOrganizationTypeText/>			•				•			
</OrganizationClassificationTypeSubtype>			•				•			
<PartyOccupationBusiness SeqNum="">									•	
<NAICSCode/>									•	
<OccupationBusinessText/>									•	
</PartyOccupationBusiness>									•	
<ElectronicAddress SeqNum="">									•	
<ElectronicAddressText/>									•	
<ElectronicAddressTypeCode/>									•	
</ElectronicAddress>									•	
<PartyAssociation SeqNum="">							•		•	
<AccountantIndicator/>									•	
<ActionTakenDateText/>									•	
<AgentIndicator/>									•	
<AppraiserIndicator/>									•	
<AttorneyIndicator/>									•	
<BorrowerIndicator/>									•	
<CustomerIndicator/>									•	
<DirectorIndicator/>									•	
<EmployeeIndicator/>									•	
<NoRelationshipToInstitutionIndicator/>									•	
<OfficerIndicator/>									•	
<OtherPartyAssociationTypeText/>									•	
<OtherRelationshipIndicator/>									•	
<OwnerShareholderIndicator/>									•	
<RelationshipContinuesIndicator/>									•	
<ResignedIndicator/>									•	
<SubjectRelationshipFinancialInstitutionTINText/>									•	
<SuspendedBarredIndicator/>									•	
<TerminatedIndicator/>									•	
<Party SeqNum="">							•	•		
<ActivityPartyTypeCode/>							•	•		
<PayLocationIndicator/>							•	•		
<SellingLocationIndicator/>							•	•		
<SellingPayingLocationIndicator/>							•	•		
<Address SeqNum="">							•	•		
<RawCityText/>							•	•		
<RawCountryCodeText/>							•	•		
<RawStateCodeText/>							•	•		

Element name	35	37	30	8	18	19	34	46	33	41
<RawStreetAddress1Text/>							●	●		
<RawZIPCode/>							●	●		
</Address>							●	●		
<PartyIdentification SeqNum="">							●	●		
<PartyIdentificationNumberText/>							●	●		
<PartyIdentificationTypeCode/>							●	●		
</PartyIdentification>							●	●		
</Party>							●	●		
</PartyAssociation>							●		●	
<PartyAccountAssociation SeqNum="">									●	
<PartyAccountAssociationTypeCode/>									●	
<Party SeqNum="">									●	●
<ActivityPartyTypeCode/>									●	●
<NonUSFinancialInstitutionIndicator/>									●	●
<PartyIdentification SeqNum="">									●	●
<PartyIdentificationNumberText/>									●	●
<PartyIdentificationTypeCode/>									●	●
</PartyIdentification>									●	●
<Account SeqNum="">									●	●
<AccountNumberText/>									●	●
<PartyAccountAssociation SeqNum="">									●	●
<AccountClosedIndicator/>									●	●
<PartyAccountAssociationTypeCode/>									●	●
</PartyAccountAssociation>									●	●
</Account>									●	●
</Party>									●	●
</PartyAccountAssociation>									●	
</Party>	●	●	●	●	●	●	●		●	

5.1. Transmitter Party Record Example

Party Type	Transmitter	minOccurs:	1	maxOccurs:	1
35	<pre> <fc2:Party SeqNum="4"> <fc2:ActivityPartyTypeCode>35</fc2:ActivityPartyTypeCode> <fc2:PartyName SeqNum="5"> <fc2:PartyNameTypeCode>L</fc2:PartyNameTypeCode> <fc2:RawPartyFullName>Transmitter legal name</fc2:RawPartyFullName> </fc2:PartyName> <fc2:Address SeqNum="6"> <fc2:RawCityText>Transmitter city</fc2:RawCityText> <fc2:RawCountryCodeText>US</fc2:RawCountryCodeText> <fc2:RawStateCodeText>VA</fc2:RawStateCodeText> <fc2:RawStreetAddress1Text>Transmitter street address</fc2:RawStreetAddress1Text> <fc2:RawZIPCode>22113</fc2:RawZIPCode> </fc2:Address> <fc2:PhoneNumber SeqNum="7"> <fc2:PhoneNumberText>7217894455</fc2:PhoneNumberText> </fc2:PhoneNumber> <fc2:PartyIdentification SeqNum="8"> <fc2:PartyIdentificationNumberText>458985215</fc2:PartyIdentificationNumberText> <fc2:PartyIdentificationTypeCode>4</fc2:PartyIdentificationTypeCode> </fc2:PartyIdentification> <fc2:PartyIdentification SeqNum="9"> <fc2:PartyIdentificationNumberText>PBSA1234</fc2:PartyIdentificationNumberText> <fc2:PartyIdentificationTypeCode>28</fc2:PartyIdentificationTypeCode> </fc2:PartyIdentification> </fc2:Party> </pre>				

Party Type	Transmitter	minOccurs:	1	maxOccurs:	1
	</fc2:Party>				

5.2. Transmitter Contact Party Record Example

Party Type	Transmitter Contact	minOccurs:	1	maxOccurs:	1
37	<pre><fc2:Party SeqNum="10"> <fc2:ActivityPartyTypeCode>37</fc2:ActivityPartyTypeCode> <fc2:PartyName SeqNum="11"> <fc2:PartyNameTypeCode>L</fc2:PartyNameTypeCode> <fc2:RawPartyFullName>Transmitter contact legal name</fc2:RawPartyFullName> </fc2:PartyName> </fc2:Party></pre>				
	</fc2:Party>				

5.3. Filing Institution Party Record Example

Party Type	Filing Institution	minOccurs:	1	maxOccurs:	1
30	<pre><fc2:Party SeqNum="12"> <fc2:ActivityPartyTypeCode>30</fc2:ActivityPartyTypeCode> <fc2:PrimaryRegulatorTypeCode>7</fc2:PrimaryRegulatorTypeCode> <fc2:PartyName SeqNum="13"> <fc2:PartyNameTypeCode>L</fc2:PartyNameTypeCode> <fc2:RawPartyFullName>Filer name</fc2:RawPartyFullName> </fc2:PartyName> <fc2:PartyName SeqNum="14"> <fc2:PartyNameTypeCode>DBA</fc2:PartyNameTypeCode> <fc2:RawPartyFullName>Alternate name</fc2:RawPartyFullName> </fc2:PartyName> <fc2:Address SeqNum="15"> <fc2:RawCityText>Rockville</fc2:RawCityText> <fc2:RawCountryCodeText>US</fc2:RawCountryCodeText> <fc2:RawStateCodeText>MD</fc2:RawStateCodeText> <fc2:RawStreetAddress1Text>123 Viers Mill Road</fc2:RawStreetAddress1Text> <fc2:RawZIPCode>20905</fc2:RawZIPCode> </fc2:Address> <fc2:PartyIdentification SeqNum="16"> <fc2:PartyIdentificationNumberText>125478965</fc2:PartyIdentificationNumberText> <fc2:PartyIdentificationTypeCode>2</fc2:PartyIdentificationTypeCode> </fc2:PartyIdentification> <fc2:PartyIdentification SeqNum="17"> <fc2:PartyIdentificationNumberText>5558789654</fc2:PartyIdentificationNumberText> <fc2:PartyIdentificationTypeCode>10</fc2:PartyIdentificationTypeCode> </fc2:PartyIdentification> <fc2:PartyIdentification SeqNum="18"> <fc2:PartyIdentificationNumberText>451256558</fc2:PartyIdentificationNumberText> <fc2:PartyIdentificationTypeCode>29</fc2:PartyIdentificationTypeCode> </fc2:PartyIdentification> <fc2:OrganizationClassificationTypeSubtype SeqNum="19"> <fc2:OrganizationSubtypeID>535</fc2:OrganizationSubtypeID> <fc2:OrganizationTypeID>5</fc2:OrganizationTypeID> </fc2:OrganizationClassificationTypeSubtype> <fc2:OrganizationClassificationTypeSubtype SeqNum="20"> <fc2:OrganizationSubtypeID>529</fc2:OrganizationSubtypeID> <fc2:OrganizationTypeID>5</fc2:OrganizationTypeID> </fc2:OrganizationClassificationTypeSubtype> </fc2:Party></pre>				
	</fc2:Party>				

5.4. Designated Contact Office Party Record Example

Party Type	Designated Contact Office	minOccurs:	1	maxOccurs:	1
8	<pre><fc2:Party SeqNum="26"> <fc2:ActivityPartyTypeCode>8</fc2:ActivityPartyTypeCode> <fc2:PartyName SeqNum="27"> <fc2:PartyNameTypeCode>L</fc2:PartyNameTypeCode> <fc2:RawPartyFullName>Designated contact office</fc2:RawPartyFullName> </fc2:PartyName> <fc2:PhoneNumber SeqNum="28"> <fc2:PhoneNumberExtensionText>1234</fc2:PhoneNumberExtensionText> <fc2:PhoneNumberText>4157653838</fc2:PhoneNumberText> </fc2:PhoneNumber> </fc2:Party> <fc2:Party SeqNum="29"></pre>				

5.5. Law Enforcement Agency Party Record Example

Party Type	Law Enforcement Agency	minOccurs:	0	maxOccurs:	1
18	<pre><fc2:Party SeqNum="21"> <fc2:ActivityPartyTypeCode>18</fc2:ActivityPartyTypeCode> <fc2:PartyName SeqNum="22"> <fc2:PartyNameTypeCode>L</fc2:PartyNameTypeCode> <fc2:RawPartyFullName>LE Contact Agency</fc2:RawPartyFullName> </fc2:PartyName> </fc2:Party> </fc2:Party></pre>				

5.6. Law Enforcement Name Party Record Example

Party Type	Law Enforcement Name	minOccurs:	0	maxOccurs:	1
19	<pre><fc2:Party SeqNum="23"> <fc2:ActivityPartyTypeCode>19</fc2:ActivityPartyTypeCode> <fc2:ContactDateText>20171105</fc2:ContactDateText> <fc2:PartyName SeqNum="24"> <fc2:PartyNameTypeCode>L</fc2:PartyNameTypeCode> <fc2:RawPartyFullName>LE Contact Name</fc2:RawPartyFullName> </fc2:PartyName> <fc2:PhoneNumber SeqNum="25"> <fc2:PhoneNumberExtensionText>5432</fc2:PhoneNumberExtensionText> <fc2:PhoneNumberText>7039051234</fc2:PhoneNumberText> </fc2:PhoneNumber> </fc2:Party> <fc2:Party SeqNum="26"></pre>				

5.7. Financial Institution Where Activity Occurred Party Record Example

Party Type	Financial Institution Where Activity Occurred	minOccurs:	1	maxOccurs:	99
34	<pre><fc2:Party SeqNum="29"> <fc2:ActivityPartyTypeCode>34</fc2:ActivityPartyTypeCode> <fc2:LossToFinancialAmountText>15000</fc2:LossToFinancialAmountText> <fc2:NoBranchActivityInvolvedIndicator>Y</fc2:NoBranchActivityInvolvedIndicator> <fc2:PayLocationIndicator>Y</fc2:PayLocationIndicator> <fc2:PrimaryRegulatorTypeCode>4</fc2:PrimaryRegulatorTypeCode> <fc2:PartyName SeqNum="30"> <fc2:PartyNameTypeCode>L</fc2:PartyNameTypeCode> <fc2:RawPartyFullName>Union Bank of California</fc2:RawPartyFullName> </fc2:PartyName></pre>				

Party Type	Financial Institution Where Activity Occurred	minOccurs:	1	maxOccurs:	99
	<pre> <fc2:PartyName SeqNum="31"> <fc2:PartyNameTypeCode>DBA</fc2:PartyNameTypeCode> <fc2:RawPartyFullName>Doing Business As Name</fc2:RawPartyFullName> </fc2:PartyName> <fc2:Address SeqNum="32"> <fc2:CityUnknownIndicator>Y</fc2:CityUnknownIndicator> <fc2:CountryCodeUnknownIndicator>Y</fc2:CountryCodeUnknownIndicator> <fc2:RawStreetAddress1Text>987 Rocky Road</fc2:RawStreetAddress1Text> <fc2:StreetAddressUnknownIndicator>Y</fc2:StreetAddressUnknownIndicator> <fc2:ZIPCodeUnknownIndicator>Y</fc2:ZIPCodeUnknownIndicator> </fc2:Address> <fc2:PartyIdentification SeqNum="33"> <fc2:PartyIdentificationNumberText>458789856</fc2:PartyIdentificationNumberText> <fc2:PartyIdentificationTypeCode>2</fc2:PartyIdentificationTypeCode> </fc2:PartyIdentification> <fc2:PartyIdentification SeqNum="34"> <fc2:PartyIdentificationNumberText>5589887789</fc2:PartyIdentificationNumberText> <fc2:PartyIdentificationTypeCode>10</fc2:PartyIdentificationTypeCode> </fc2:PartyIdentification> <fc2:PartyIdentification SeqNum="35"> <fc2:PartyIdentificationNumberText>4578958658</fc2:PartyIdentificationNumberText> <fc2:PartyIdentificationTypeCode>29</fc2:PartyIdentificationTypeCode> </fc2:PartyIdentification> <fc2:OrganizationClassificationTypeSubtype SeqNum="36"> <fc2:OrganizationSubtypeID>533</fc2:OrganizationSubtypeID> <fc2:OrganizationTypeID>5</fc2:OrganizationTypeID> </fc2:OrganizationClassificationTypeSubtype> <fc2:OrganizationClassificationTypeSubtype SeqNum="37"> <fc2:OrganizationSubtypeID>5999</fc2:OrganizationSubtypeID> <fc2:OrganizationTypeID>5</fc2:OrganizationTypeID> <fc2:OtherOrganizationSubTypeText>other S/F institution description</fc2:OtherOrganizationSubTypeText> </fc2:OrganizationClassificationTypeSubtype> <fc2:PartyAssociation SeqNum="38"> <fc2:Party SeqNum="39"> <fc2:ActivityPartyTypeCode>46</fc2:ActivityPartyTypeCode> ... </fc2:Party> </fc2:PartyAssociation> </fc2:Party> <fc2:PartyAssociation SeqNum="38"> </pre>				

5.8. Branch Where Activity Occurred Party Record Example

Party Type	Branch Where Activity Occurred	minOccurs:	0	maxOccurs:	99
46	<pre> <fc2:Party SeqNum="39"> <fc2:ActivityPartyTypeCode>46</fc2:ActivityPartyTypeCode> <fc2:SellingLocationIndicator>Y</fc2:SellingLocationIndicator> <fc2:Address SeqNum="40"> <fc2:RawCityText>Cityville</fc2:RawCityText> <fc2:RawCountryCodeText>US</fc2:RawCountryCodeText> <fc2:RawStateCodeText>VA</fc2:RawStateCodeText> <fc2:RawStreetAddress1Text>123 Address Way</fc2:RawStreetAddress1Text> <fc2:RawZIPCode>547898856</fc2:RawZIPCode> </fc2:Address> <fc2:PartyIdentification SeqNum="41"> <fc2:PartyIdentificationNumberText>445564615654</fc2:PartyIdentificationNumberText> <fc2:PartyIdentificationTypeCode>14</fc2:PartyIdentificationTypeCode> </pre>				

Party Type	Branch Where Activity Occurred	minOccurs:	0	maxOccurs:	99
	</fc2:PartyIdentification> </fc2:Party> <fc2:Party SeqNum="42">				

5.9. Subject Party Record Example

Party Type	Subject	minOccurs:	1	maxOccurs:	999
33	<fc2:Party SeqNum="61"> <fc2:ActivityPartyTypeCode>33</fc2:ActivityPartyTypeCode> <fc2:AdmissionConfessionYesIndicator>Y</fc2:AdmissionConfessionYesIndicator> <fc2:BothPurchaserSenderPayeeReceiveIndicator>Y</fc2:BothPurchaserSenderPayeeReceiveIndicator> > <fc2:FemaleGenderIndicator>Y</fc2:FemaleGenderIndicator> <fc2:IndividualBirthDateText>19801025</fc2:IndividualBirthDateText> <fc2:PartyName SeqNum="62"> <fc2:PartyNameTypeCode>L</fc2:PartyNameTypeCode> <fc2:RawEntityIndividualLastName>Mann</fc2:RawEntityIndividualLastName> <fc2:RawIndividualFirstName>Janice</fc2:RawIndividualFirstName> </fc2:PartyName> <fc2:PartyName SeqNum="63"> <fc2:PartyNameTypeCode>AKA</fc2:PartyNameTypeCode> <fc2:RawPartyFullName>Janda</fc2:RawPartyFullName> </fc2:PartyName> <fc2:PartyName SeqNum="64"> <fc2:PartyNameTypeCode>AKA</fc2:PartyNameTypeCode> <fc2:RawPartyFullName>Jan</fc2:RawPartyFullName> </fc2:PartyName> <fc2:Address SeqNum="65"> <fc2:CityUnknownIndicator>Y</fc2:CityUnknownIndicator> <fc2:CountryCodeUnknownIndicator>Y</fc2:CountryCodeUnknownIndicator> <fc2:StateCodeUnknownIndicator>Y</fc2:StateCodeUnknownIndicator> <fc2:StreetAddressUnknownIndicator>Y</fc2:StreetAddressUnknownIndicator> <fc2:ZIPCodeUnknownIndicator>Y</fc2:ZIPCodeUnknownIndicator> </fc2:Address> <fc2:PhoneNumber SeqNum="66"> <fc2:PhoneNumberText>6194760276</fc2:PhoneNumberText> <fc2:PhoneNumberTypeCode>R</fc2:PhoneNumberTypeCode> </fc2:PhoneNumber> <fc2:PhoneNumber SeqNum="67"> <fc2:PhoneNumberExtensionText>5584</fc2:PhoneNumberExtensionText> <fc2:PhoneNumberText>6589784589</fc2:PhoneNumberText> <fc2:PhoneNumberTypeCode>W</fc2:PhoneNumberTypeCode> </fc2:PhoneNumber> <fc2:PartyIdentification SeqNum="68"> <fc2:IdentificationPresentUnknownIndicator>Y</fc2:IdentificationPresentUnknownIndicator> <fc2:OtherIssuerCountryText>US</fc2:OtherIssuerCountryText> <fc2:OtherIssuerStateText>CA</fc2:OtherIssuerStateText> <fc2:OtherPartyIdentificationTypeText>Student ID</fc2:OtherPartyIdentificationTypeText> <fc2:PartyIdentificationNumberText>660623559</fc2:PartyIdentificationNumberText> <fc2:PartyIdentificationTypeCode>999</fc2:PartyIdentificationTypeCode> </fc2:PartyIdentification> <fc2:PartyIdentification SeqNum="69"> <fc2:TINUnknownIndicator>Y</fc2:TINUnknownIndicator> </fc2:PartyIdentification> <fc2:PartyOccupationBusiness SeqNum="70"> <fc2:NAICSCode>7548</fc2:NAICSCode> <fc2:OccupationBusinessText>Mechanic</fc2:OccupationBusinessText>				

Party Type	Subject	minOccurs:	1	maxOccurs:	999
	<pre> </fc2:PartyOccupationBusiness> <fc2:ElectronicAddress SeqNum="71"> <fc2:ElectronicAddressText>jan@gmail.com</fc2:ElectronicAddressText> <fc2:ElectronicAddressTypeCode>E</fc2:ElectronicAddressTypeCode> </fc2:ElectronicAddress> <fc2:ElectronicAddress SeqNum="72"> <fc2:ElectronicAddressText>janda.org</fc2:ElectronicAddressText> <fc2:ElectronicAddressTypeCode>U</fc2:ElectronicAddressTypeCode> </fc2:ElectronicAddress> <fc2:PartyAssociation SeqNum="73"> <fc2:NoRelationshipToInstitutionIndicator>Y</fc2:NoRelationshipToInstitutionIndicator> <fc2:SubjectRelationshipFinancialInstitutionTINText>458789856</fc2:SubjectRelationshipFinancialInsti tutionTINText> </fc2:PartyAssociation> <fc2:PartyAccountAssociation SeqNum="74"> <fc2:PartyAccountAssociationTypeCode>7</fc2:PartyAccountAssociationTypeCode> <fc2:Party SeqNum="75"> <fc2:ActivityPartyTypeCode>41</fc2:ActivityPartyTypeCode> ... </fc2:Party> </fc2:PartyAccountAssociation> </fc2:Party> <fc2:Party SeqNum="75"> </pre>				

5.10. Financial Institution Where Account is Held Party Record Example

Party Type	Financial Institution Where Account is Held	minOccurs:	0	maxOccurs:	99
41	<pre> <fc2:Party SeqNum="75"> <fc2:ActivityPartyTypeCode>41</fc2:ActivityPartyTypeCode> <fc2:NonUSFinancialInstitutionIndicator>Y</fc2:NonUSFinancialInstitutionIndicator> <fc2:PartyIdentification SeqNum="76"> <fc2:PartyIdentificationNumberText>458789856</fc2:PartyIdentificationNumberText> <fc2:PartyIdentificationTypeCode>4</fc2:PartyIdentificationTypeCode> </fc2:PartyIdentification> <fc2:Account SeqNum="77"> <fc2:AccountNumberText>1502417873</fc2:AccountNumberText> <fc2:PartyAccountAssociation SeqNum="78"> <fc2:AccountClosedIndicator>Y</fc2:AccountClosedIndicator> <fc2:PartyAccountAssociationTypeCode>5</fc2:PartyAccount- AssociationTypeCode> </fc2:PartyAccountAssociation> </fc2:Account> <fc2:Account SeqNum="79"> <fc2:AccountNumberText>5477887896</fc2:AccountNumberText> <fc2:PartyAccountAssociation SeqNum="80"> <fc2:AccountClosedIndicator>Y</fc2:AccountClosedIndicator> <fc2:PartyAccountAssociationTypeCode>5</fc2:PartyAccount- AssociationTypeCode> </fc2:PartyAccountAssociation> </fc2:Account> </fc2:Party> <fc2:Party SeqNum="86"> </pre>				

6. FinCEN SAR XML Acknowledgement Format

The FinCEN SAR XML batch acknowledgement file defined below is provided in XML format. The acknowledgement file will contain a BSA Identifier and any corresponding acknowledgement errors associated with each FinCEN SAR <Activity> element received in the batch submission. Please visit https://www.fincen.gov/sites/default/files/schema/base/EFL_BatchAcknowledgementSchema.xsd to access the FinCEN XML 2.0 batch acknowledgement schema file.

6.1. XML File Structure

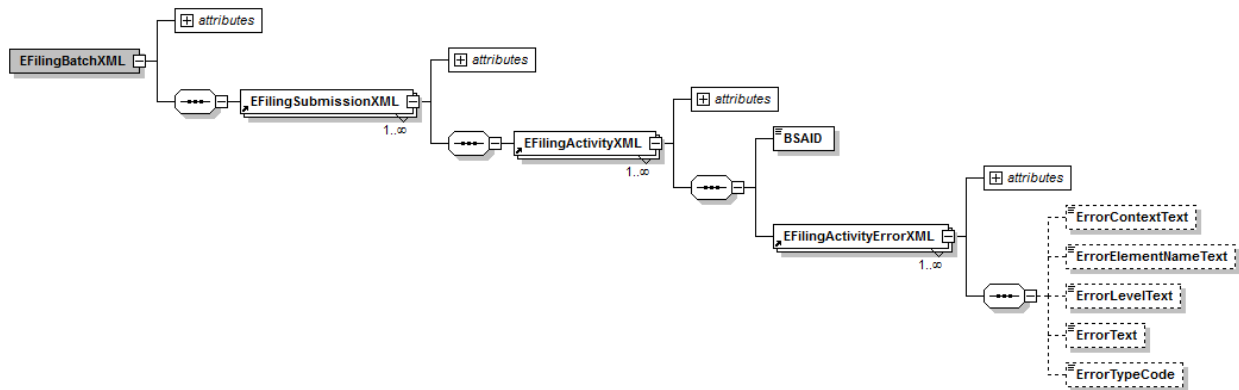

6.1.1. XML declaration/prolog

The XML declaration appears on the first line of the acknowledgement file.

Element Name:	?xml	minOccurs:	1	maxOccurs:	1
Description:	XML declaration/prolog. This is the XML declaration which specifies the XML version and character encoding used in the file.				
Attribute(s):	version. The version number of the XML. The value recorded will be "1.0" encoding. The character encoding used for the XML. The value recorded will be "UTF-8"				
Parent Element:	n/a				
Element Restriction(s)	This declaration will always be recorded on the first line of the file.				
Value Restriction(s):	The value provided will be: <ul style="list-style-type: none"> <?xml version="1.0" encoding="UTF-8"?> 				
Remarks:	none				
Example:	<?xml version="1.0" encoding="UTF-8"?>				

6.1.2. EFilingBatchXML

The <EFilingBatchXML> element is the first element recorded in the file and is considered the root element.

Element Name:	EFilingBatchXML	minOccurs:	1	maxOccurs:	1
Description:	Batch acknowledgement (header). This is the container for the contents of the batch acknowledgement file. This element is parent to the following sub-elements: EFilingSubmissionXML * NOTE: Elements marked with an asterisk * contain sub-elements.				

Attribute(s):	SeqNum (this is a sequential number assigned by FinCEN to identify the corresponding element in the associated batch file) StatusCode (this will have a value of "A" to indicate "Acknowledged")
Parent Element:	n/a (this is the root element in the acknowledgment file)
Element Restriction(s):	This element will always be recorded.
Value Restriction(s):	n/a
Remarks:	n/a
Example:	<EFilingBatchXML SeqNum="1" StatusCode="A">

6.1.3. EFilingSubmissionXML

The <EFilingSubmissionXML> element directly follows the <EFilingBatchXML> root element. This element is for FinCEN use only.

Element Name:	EFilingSubmissionXML	minOccurs:	1	maxOccurs:	1
Description:	Submission acknowledgement (header). This is the container for all FinCEN SAR <Activity> elements recorded in the associated batch submission. This element is parent to the following sub-elements: EFilingActivityXML *				
	NOTE: Elements marked with an asterisk * contain sub-elements.				
Attribute(s):	xmlns (this will always be www.fincen.gov/base) SeqNum (this is a sequential number assigned by FinCEN to identify the corresponding element in the associated batch file) StatusCode (this will have a value of "A" to indicate "Acknowledged")				
Parent Element:	EFilingBatchXML				
Element Restriction(s):	This element will always be recorded.				
Value Restriction(s):	n/a				
Remarks:	This element is for FinCEN use only.				
Example:	<EFilingSubmissionXML xmlns="www.fincen.gov/base" SeqNum="1" StatusCode="A">				

6.1.4. EFilingActivityXML

Each <EFilingActivityXML> element in the batch acknowledgement file corresponds with each FinCEN SAR <Activity> element recorded in the original batch submission along with the sequence number (SeqNum) attribute value.

Element Name:	EFilingActivityXML	minOccurs:	1	maxOccurs:	unbounded
Description:	Activity acknowledgement (header). This is the container for acknowledgement information for each FinCEN SAR <Activity> element recorded in the associated batch submission. This element is parent to the following sub-elements: BSAID EFilingActivityErrorXML *				
	NOTE: Elements marked with an asterisk * contain sub-elements.				
Attribute(s):	SeqNum (this sequential number matches the value recorded in the associated batch submission)				

Parent Element:	EfilingSubmissionXML
Value Restriction(s):	n/a
Remarks:	none
Example:	<pre><EfilingActivityXML SeqNum="1"> <BSAID>31000055053784</BSAID> <EfilingActivityErrorXML SeqNum="1"/> </EfilingActivityXML></pre>

Element Name:	BSAID	minOccurs:	1	maxOccurs:	1
Description:	Activity acknowledgement BSA Identifier (text). This element identifies the BSA Identifier (BSA ID) assigned by FinCEN to the FinCEN SAR document.				
Attribute(s):	n/a				
Parent Element:	EfilingActivityXML				
Value Restriction(s):	14 characters (numeric only)				
Remarks:	none				
Example:	<BSAID>31000055053784</BSAID>				

6.1.5. EfilingActivityErrorXML

There will be at least one <EfilingActivityErrorXML> element for each <EfilingActivityXML> element in the batch acknowledgement file.

Element Name:	EfilingActivityErrorXML	minOccurs:	1	maxOccurs:	unbounded
Description:	<p>Activity acknowledgement error (header). This is the container for error information generated during processing of the associated batch submission related to the FinCEN SAR activity.</p> <p>This element is parent to the following sub-elements:</p> <ul style="list-style-type: none"> ErrorContextText ErrorElementNameText ErrorLevelText ErrorText ErrorTypeCode 				
Attribute(s):	SeqNum (this is a sequential number assigned by FinCEN)				
Parent Element:	EfilingActivityXML				
Value Restriction(s):	n/a				
Remarks:	If there are no errors identified for the FinCEN SAR activity, then the <EfilingActivityErrorXML> element will be recorded with a self-closing tag (e.g. <EfilingActivityErrorXML SeqNum="1"/>) and this element will not be recorded.				
Example:	<pre><EfilingActivityErrorXML SeqNum="1"> <ErrorContextText>EfilingBatchXML/Activity[1]/Party[25]/PartyIdentification[49]/PartyIdentificationNumberText</ErrorContextText> <ErrorElementNameText>PartyIdentificationNumberText</ErrorElementNameText> <ErrorLevelText>WARN</ErrorLevelText> <ErrorText>The value recorded for the EIN or SSN/ITIN is an invalid number string.</ErrorText> <ErrorTypeCode>C21</ErrorTypeCode> </EfilingActivityErrorXML> <EfilingActivityErrorXML SeqNum="2"></pre>				

<pre> <ErrorContextText>EFilingBatchXML/Activity[1]/Party[78]/PartyName[84]/RawIndividualFirstN ame</ErrorContextText> <ErrorElementNameText>RawIndividualFirstName</ErrorElementNameText> <ErrorLevelText>WARN</ErrorLevelText> <ErrorText>The element is not recorded or does not contain a value for an individual Subject and unknown is not indicated.</ErrorText> <ErrorTypeCode>C4</ErrorTypeCode> </EFilingActivityErrorXML> </pre>

Element Name:	ErrorContextText	minOccurs:	0	maxOccurs:	1
Description:	Acknowledgement error type (text). This element identifies the element location (within the associated batch submission) that triggered the error by identifying the name and sequence number of the element's <Parent> element.				
Attribute(s):	n/a				
Parent Element:	EFilingActivityErrorXML				
Value Restriction(s):	1-4000 characters				
Remarks:	If there are no errors identified for the FinCEN SAR activity, then the <EFilingActivityErrorXML> element will be recorded with a self-closing tag (e.g. <EFilingActivityErrorXML SeqNum="1"/>) and this element will not be recorded.				
Example:	<ErrorContextText>EFilingBatchXML/Activity[1]/Party[25]/PartyIdentification[49]/PartyIdentificationNumberText</ErrorContextText>				

Element Name:	ErrorElementNameText	minOccurs:	0	maxOccurs:	1
Description:	Element acknowledgement error association (text). This element identifies the element name from the associated batch submission that triggered the error.				
Attribute(s):	n/a				
Parent Element:	EFilingActivityErrorXML				
Value Restriction(s):	1-512 characters				
Remarks:	If there are no errors identified for the FinCEN SAR activity, then the <EFilingActivityErrorXML> element will be recorded with a self-closing tag (e.g. <EFilingActivityErrorXML SeqNum="1"/>) and this element will not be recorded.				
Example:	<ErrorElementNameText>PartyIdentificationNumberText</ErrorElementNameText>				

Element Name:	ErrorLevelText	minOccurs:	0	maxOccurs:	1
Description:	Acknowledgement error severity level (text). This element identifies the level of severity associated with the error.				
Attribute(s):	n/a				
Parent Element:	EFilingActivityErrorXML				
Value Restriction(s):	1-50 characters				
Remarks:	If there are no errors identified for the FinCEN SAR activity, then the <EFilingActivityErrorXML> element will be recorded with a self-closing tag (e.g. <EFilingActivityErrorXML SeqNum="1"/>) and this element will not be recorded.				
Example:	<ErrorLevelText>WARN</ErrorLevelText>				

Element Name:	ErrorText	minOccurs:	0	maxOccurs:	1
---------------	-----------	------------	---	------------	---

Description:	Acknowledgement error description (text). This element identifies the description of the error.
Attribute(s):	n/a
Parent Element:	EfilingActivityErrorXML
Value Restriction(s):	1-525 characters
Remarks:	If there are no errors identified for the FinCEN SAR activity, then the <EfilingActivityErrorXML> element will be recorded with a self-closing tag (e.g. <EfilingActivityErrorXML SeqNum="1"/>) and this element will not be recorded.
Example:	<ErrorText>The value recorded for the EIN or SSN/ITIN is an invalid number string.</ErrorText>

Element Name:	ErrorTypeCode	minOccurs:	0	maxOccurs:	1
Description:	Acknowledgement error type (code). This element identifies the code associated with the error.				
Attribute(s):	n/a				
Parent Element:	EfilingActivityErrorXML				
Value Restriction(s):	1-50 characters				
Remarks:	If there are no errors identified for the FinCEN SAR activity, then the <EfilingActivityErrorXML> element will be recorded with a self-closing tag (e.g. <EfilingActivityErrorXML SeqNum="1"/>) and this element will not be recorded.				
Example:	<ErrorTypeCode>C4</ErrorTypeCode>				

6.2. Acknowledgement XML Example

The following is a sample FinCEN SAR acknowledgement XML generated by FinCEN and delivered to the batch filer.

File type	FinCEN SAR XML Batch Acknowledgement (Sample)
Example:	<pre> <?xml version="1.0" encoding="UTF-8"?> <EfilingBatchXML xmlns="www.fincen.gov/base" SeqNum="1" StatusCode="A"> <EfilingSubmissionXML SeqNum="1" StatusCode="A"> <EfilingActivityXML SeqNum="1"> <BSAID>31000055053784</BSAID> <EfilingActivityErrorXML SeqNum="1"> <ErrorContextText>EfilingBatchXML/Activity[1]/Party[25]/PartyIdentification[49]/PartyIdentificationNumberText</ErrorContextText> <ErrorElementNameText>PartyIdentificationNumberText</ErrorElementNameText> <ErrorLevelText>WARN</ErrorLevelText> <ErrorText>The value recorded for the EIN or SSN/ITIN is an invalid number string.</ErrorText> <ErrorTypeCode>C21</ErrorTypeCode> </EfilingActivityErrorXML> <EfilingActivityErrorXML SeqNum="2"> <ErrorContextText>EfilingBatchXML/Activity[1]/Party[78]/PartyName[84]/RawIndividualFirstName</ErrorContextText> <ErrorElementNameText>RawIndividualFirstName</ErrorElementNameText> <ErrorLevelText>WARN</ErrorLevelText> <ErrorText>The element is not recorded or does not contain a value for an individual Subject and unknown is not indicated.</ErrorText> <ErrorTypeCode>C4</ErrorTypeCode> </EfilingActivityErrorXML> </EfilingActivityXML> <EfilingActivityXML SeqNum="2"> <BSAID>31000055053785</BSAID> <EfilingActivityErrorXML SeqNum="1"/> </EfilingActivityXML> <EfilingActivityXML SeqNum="3"> <BSAID>31000055053786</BSAID> <EfilingActivityErrorXML SeqNum="1"/> </EfilingActivityXML> </EfilingSubmissionXML> </EfilingBatchXML> </pre>

	</E filingSubmissionXML> </E filingBatchXML>
Notes:	The sample above consists of three (3) FinCEN SAR activities based on the original FinCEN SAR batch submission: <ul style="list-style-type: none"> • Each FinCEN SAR from the original batch submission is associated with a <E filingActivityXML> element • Each FinCEN SAR receives a unique BSA Identifier (BSA ID) • FinCEN SAR (BSA ID: 31000055053784) contains two errors (C21 & C4) • FinCEN SAR (BSA ID: 31000055053785) contains no errors • FinCEN SAR (BSA ID: 31000055053786) contains no errors

7. Attachment A – Error Descriptions

The following table lists the errors that your batch may receive as a result of missing or invalid data formatting. FinCEN strongly encourages that filers first test their XML batch files for schema compliance using the schemas available at www.fincen.gov/base. Your batch file should pass schema validation before you attempt to submit to FinCEN. As a result, this table does not include all possible schema validation errors, as these will be handled by your XML software during testing. Your batch file must pass schema validation before attempting to submit to FinCEN via BSA E-Filing; otherwise, it will be rejected.

Error Level

Fatal

Batch rejection

These errors are related to the batch format and must be resolved before attempting to resubmit the batch.

Primary Warning

Batch acceptance with warning(s) classified as primary data errors

These errors violate electronic filing requirements or report instructions and so degrade FinCEN SAR data quality that they must be corrected (along with warning errors) as a correction/amendment. Error codes marked with an asterisk () are primary warnings.*

Warning

Batch acceptance with warning(s) classified as secondary data errors.

These errors that violate electronic filing requirements or report instructions but have a lesser impact on FinCEN SAR data quality.

7.1. Miscellaneous Errors

These errors can occur throughout the batch file:

Code	Error Text	Severity	Associated Element(s)	Form Reference
A0	The XML declaration/prolog is not recorded with the required values or it is not recorded on the first line of the batch file.	Fatal	Misc.	Misc.
A1	The element is not recorded for the required party type.	Warning	Misc.	Misc.
A2	The critical element is not recorded for the required party type.	Fatal	Misc.	Misc.
A3	The element is recorded for an inappropriate party type.	Fatal	Misc.	Misc.
A4	The critical element is not recorded.	Fatal	Misc.	Misc.
A5	The element is not recorded.	Warning	Misc.	Misc.
A6	The element exceeds the maximum occurrence threshold.	Fatal	Misc.	Misc.
A7	The element is missing a "SeqNum" attribute	Fatal	Misc.	Misc.
A8	The element contains a "SeqNum" attribute with a duplicate or invalid value	Fatal	Misc.	Misc.

Code	Error Text	Severity	Associated Element(s)	Form Reference
A9	One or more of the attributes are missing, incorrectly formatted, or contain an invalid value	Fatal	Misc.	Misc.
A10	The reported total count of all activities in the batch does not match the actual count.	Fatal	Misc.	Misc.
A11	The reported sum of all total amounts recorded in the batch does not match the actual amount.	Fatal	Misc.	Misc.
A12	The reported count of the total number of parties in the batch does not match the actual count.	Fatal	Misc.	Misc.
A13	The reported count of activities containing an attachment does not match the actual count.	Fatal	Misc.	Misc.
A14	The reported count of attachments does not match the actual count.	Fatal	Misc.	Misc.
A15	Cannot continue processing the submitted file because of previous errors encountered.	Fatal	Misc.	Misc.
A16	One, or more, invalid characters were present in the submitted file.	Fatal	Misc.	Misc.
A17	The namespace prefix for the element is invalid.	Fatal	Misc.	Misc.
A18	Unexpected element sequence. The element is not allowed at this location.	Fatal	Misc.	Misc.
A19	Schema validation failure. The XML file does not conform to the defined schema located at https://www.fincen.gov/base/EFL_SARXBatchSchema.xsd .	Fatal	Misc.	Misc.
A20	This submission cannot be accepted because it contains significant errors. Please fix and resubmit the file.	Fatal	Misc.	Misc.
A21	This submission has been accepted and will be processed by FinCEN, however it contains some errors which need to be corrected once this submission has been acknowledged.	Warning	Misc.	Misc.
A23	The value recorded is not appropriate for the associated party type.	Fatal	Misc.	Misc.
A24	Unknown is indicated for data that is provided.	Warning	Misc.	Misc.
A25	Unknown is indicated for data that is provided and unknown is not a valid response.	Fatal	Misc.	Misc.
A27	The element recorded conflicts with one or more recorded elements.	Fatal	Misc.	Misc.
A29	The value recorded does not contain an associated type.	Fatal	Misc.	Misc.
A30	The value is missing or invalid.	Fatal	Misc.	Misc.

7.2. Document Errors

These errors can occur at the FinCEN SAR document level:

Code	Error Text	Severity	Associated Element(s)	Form Reference
B0	The value recorded is not equal to "Y" or not equal to null.	Fatal	All indicator elements	Misc.
B1	The element is not recorded.	Fatal	PartyNameTypeCode	Misc.
B2	The element is recorded but with no value (i.e. the value is null).	Fatal	PartyNameTypeCode	Misc.
B3	The element contains an invalid code.	Fatal	PartyNameTypeCode	Misc.
B4	The element is recorded with a value that is not approved for the associated party type (see Value Restrictions for more information).	Fatal	PartyNameTypeCode	Misc.
B5	The element is not recorded and the <PartyIdentificationNumberText> contains a value.	Fatal	PartyIdentificationTypeCode	Misc.
B6	The element contains an invalid code.	Fatal	PartyIdentificationTypeCode	Misc.
B7	The element is recorded but with no value (i.e. the value is null).	Fatal	PartyIdentificationTypeCode	Misc.
B9	The element is not recorded.	Fatal	PartyIdentificationTypeCode	Misc.
B10	The element is not recorded.	Fatal	ActivityPartyTypeCode	Misc.
B11	The element is recorded but with no value (i.e. the value is null).	Fatal	ActivityPartyTypeCode	Misc.
B12	The element contains an invalid code.	Fatal	ActivityPartyTypeCode	Misc.
B13	The element is not recorded.	Fatal	ActivityAssociation	1. Type of Filing
B14	The element is recorded but none of the following sub-elements are recorded with a "Y" value: InitialReportIndicator, CorrectsAmendsPriorReportIndicator, and ContinuingActivityReportIndicator.	Fatal	ActivityAssociation	1. Type of Filing
B15	InitialReportIndicator contains a "Y" value and either/both of the following elements also contain a "Y" value: CorrectsAmendsPriorReportIndicator, ContinuingActivityReportIndicator.	Warning	ActivityAssociation	1. Type of Filing
B16*	The element is not recorded and the filing type is corrects/amends prior report and/or continuing activity report.	Warning	EFilingPriorDocumentNumber	01e. Type of Filing: e. Prior report BSA Identification Number if items 1b or 1c are checked
B17*	The element is recorded but without a value (i.e. the value is null).	Warning	EFilingPriorDocumentNumber	01e. Type of Filing: e. Prior report BSA Identification Number if items 1b or 1c are checked
B18*	The element is recorded with a valid value but the filing type is not corrects/amends prior report and/or continuing activity report.	Warning	EFilingPriorDocumentNumber	01e. Type of Filing: e. Prior report BSA Identification Number if items 1b or 1c are checked
B19*	The value recorded does not equal 14 numeric characters.	Warning	EFilingPriorDocumentNumber	01e. Type of Filing: e. Prior report BSA Identification Number if items 1b or 1c are checked
B20	The value recorded contains one or more non-numeric characters.	Warning	TotalSuspiciousAmountText	29. Amount involved in this report
B21	The element is not recorded or does not contain a value and unknown or no amount involved is not indicated.	Warning	TotalSuspiciousAmountText	29. Amount involved in this report

Code	Error Text	Severity	Associated Element(s)	Form Reference
B22*	The element is recorded with a value while unknown and/or no amount involved is indicated.	Warning	TotalSuspiciousAmountText	29. Amount involved in this report
B23*	The element is not recorded or does not contain a value.	Warning	SuspiciousActivityFromDateText	30a. Date or date range of suspicious activity (From)
B24*	The value recorded for the element is not in the required format (YYYYMMDD).	Warning	SuspiciousActivityFromDateText	30a. Date or date range of suspicious activity (From)
B25	The value recorded is greater than the date recorded for SuspiciousActivityToDateText.	Warning	SuspiciousActivityFromDateText	30a. Date or date range of suspicious activity (From)
B26*	The value recorded for the element is not in the required format (YYYYMMDD).	Warning	SuspiciousActivityToDateText	30b. Date or date range of suspicious activity (To)
B27*	The value recorded contains one or more non-numeric characters.	Warning	CumulativeTotalViolationAmountText	31. Cumulative amount
B28*	The element is not recorded or does not contain a value and continuing activity report is indicated.	Warning	CumulativeTotalViolationAmountText	31. Cumulative amount
B29	The element is recorded with a value and continuing activity report is not indicated.	Warning	CumulativeTotalViolationAmountText	31. Cumulative amount
B30	The cumulative amount recorded is less than the total amount recorded for TotalSuspiciousAmountText.	Warning	CumulativeTotalViolationAmountText	31. Cumulative amount
B31	The element is not recorded.	Fatal	SuspiciousActivity	32-42. Suspicious Activity Information
B32	The element is not recorded.	Fatal	SuspiciousActivityClassification	32-42. Suspicious Activity Classification
B33	The element is not recorded.	Fatal	SuspiciousActivityTypeID	32-42. Suspicious Activity: Type (ACH, Ponzi scheme, Chip walking, etc.)
B34	The element is recorded but without a value (i.e. the value is null).	Fatal	SuspiciousActivityTypeID	32-42. Suspicious Activity: Type (ACH, Ponzi scheme, Chip walking, etc.)
B35	The element contains an invalid code.	Fatal	SuspiciousActivityTypeID	32-42. Suspicious Activity: Type (ACH, Ponzi scheme, Chip walking, etc.)
B36	The element is not recorded.	Fatal	SuspiciousActivitySubtypeID	32a-42z. Suspicious Activity: Subtype (Structuring, Terrorist financing, Cyber event, etc.)
B37	The element is recorded but without a value (i.e. the value is null).	Fatal	SuspiciousActivitySubtypeID	32a-42z. Suspicious Activity: Subtype (Structuring, Terrorist financing, Cyber event, etc.)
B38	The element contains an invalid code.	Fatal	SuspiciousActivitySubtypeID	32a-42z. Suspicious Activity: Subtype (Structuring, Terrorist financing, Cyber event, etc.)
B39	The element contains a value that is not appropriate for the type of suspicious activity recorded.	Fatal	SuspiciousActivitySubtypeID	32a-42z. Suspicious Activity: Subtype (Structuring, Terrorist financing, Cyber event, etc.)
B40	The element is not recorded or does not contain a value and the subtype of suspicious activity is equal to Other.	Warning	OtherSuspiciousActivityTypeText	32z-42z. Suspicious Activity: Other Type Description

Code	Error Text	Severity	Associated Element(s)	Form Reference
B41	The element is recorded with a value but the subtype of suspicious activity is not equal to Other.	Warning	OtherSuspiciousActivityTypeText	32z-42z. Suspicious Activity: Other Type Description
B42*	The value recorded for the element is not in the required format (see Value Restrictions for format requirements).	Warning	IPAddressText	43. IP Address: Address
B43*	The value recorded for the element is not in the required format (YYYYMMDD).	Warning	ActivityIPAddressDateText	43a. IP Address: Date
B44*	The value recorded for the element is not in the required format (HH:MM:SS).	Warning	ActivityIPAddressTimeStampText	43b. IP Address: Timestamp
B45	The element is not recorded or does not contain.	Warning	EventValueText	44a1-j1,z1. Cyber Event Indicator: Event value
B46	The value recorded is not valid based on the type of cyber event (see Value Restrictions for format requirements).	Warning	EventValueText	44a1-j1,z2. Cyber Event Indicator: Event value
B47	The element is recorded for a cyber-event type that is not applicable to this data (see Element Restrictions for more information).	Fatal	CyberEventDataText	44a2,h2. Cyber Event Indicator: Date
B48*	The value recorded for the element is not in the required format (YYYYMMDD).	Warning	CyberEventDataText	44a2,h3. Cyber Event Indicator: Date
B49*	The element is recorded for a cyber-event type that is not applicable to this data (see Element Restrictions for more information).	Fatal	CyberEventTimeStampText	44a3,h3. Cyber Event Indicator: Timestamp
B50	The value recorded for the element is not in the required format (HH:MM:SS).	Warning	CyberEventTimeStampText	44a3,h4. Cyber Event Indicator: Timestamp
B51	The element is not recorded or does not contain a value.	Fatal	CyberEventIndicatorsTypeCode	44a-j,z. Cyber Event Indicator: Type (Command and Control IP address, Targeted system, etc.)
B52	The element contains an invalid code.	Fatal	CyberEventIndicatorsTypeCode	44a-j,z. Cyber Event Indicator: Type (Command and Control IP address, Targeted system, etc.)
B53	The element is not recorded or does not contain a value and the <CyberEventIndicatorsTypeCode> is equal to "11" Other.	Warning	CyberEventTypeOtherText	44z. Cyber Event Indicator: Other Description
B54	The element is recorded with a value and the <CyberEventIndicatorsTypeCode> is not equal to "11" Other.	Warning	CyberEventTypeOtherText	44z. Cyber Event Indicator: Other Description
B55	The element is not recorded.	Fatal	AssetTypeID	45/46. Assets: Type (45. Financial product) (46. Financial instrument/payment mechanism)
B56	The element is recorded but without a value (i.e. the value is null).	Fatal	AssetTypeID	45/46. Assets: Type (45. Financial product) (46. Financial instrument/payment mechanism)

Code	Error Text	Severity	Associated Element(s)	Form Reference
B57	The element contains an invalid code.	Fatal	AssetTypeID	45/46. Assets: Type (45. Financial product) (46. Financial instrument/payment mechanism)
B58	The element is not recorded.	Fatal	AssetSubtypeID	45a-t,z/46a-i,z. Assets: Subtype (45. Bonds/Notes, Microcap securities, etc.) (46. Bank/cashier's check, Funds transfer, etc.)
B59	The element is recorded but without a value (i.e. the value is null).	Fatal	AssetSubtypeID	45a-t,z/46a-i,z. Assets: Subtype (45. Bonds/Notes, Microcap securities, etc.) (46. Bank/cashier's check, Funds transfer, etc.)
B60	The element contains an invalid code.	Fatal	AssetSubtypeID	45a-t,z/46a-i,z. Assets: Subtype (45. Bonds/Notes, Microcap securities, etc.) (46. Bank/cashier's check, Funds transfer, etc.)
B61	The element contains a value that is not appropriate for the type of asset recorded.	Fatal	AssetSubtypeID	45a-t,z/46a-i,z. Assets: Subtype (45. Bonds/Notes, Microcap securities, etc.) (46. Bank/cashier's check, Funds transfer, etc.)
B62	The element is not recorded or does not contain a value and Other is indicated for the <AssetSubtypeID> element.	Warning	OtherAssetSubtypeText	45z/46z. Assets: Subtype Other Description
B63	The element is recorded with a value and Other is not indicated for the <AssetSubtypeID> element.	Warning	OtherAssetSubtypeText	45z/46z. Assets: Subtype Other Description
B64	The element is not recorded or does not contain a value.	Warning	AssetAttributeDescriptionText	47-50. Assets Attribute: Value/Description
B65	The value recorded is not valid based on the type of asset attribute (see Value Restrictions for format requirements).	Warning	AssetAttributeDescriptionText	47-50. Assets Attribute: Value/Description
B66	The element is not recorded.	Fatal	AssetAttributeTypeID	47-50. Assets Attribute: Type (Commodity, Product/Instrument, Market where traded, or CUSIP)
B67	The element is recorded but without a value (i.e. the value is null).	Fatal	AssetAttributeTypeID	47-50. Assets Attribute: Type (Commodity, Product/Instrument, Market where traded, or CUSIP)
B68	The element contains an invalid code.	Fatal	AssetAttributeTypeID	47-50. Assets Attribute: Type (Commodity, Product/Instrument, Market where traded, or CUSIP)
B69	The element is not recorded.	Fatal	FilingDateText	95. Date filed

Code	Error Text	Severity	Associated Element(s)	Form Reference
B70	The element is recorded but without a value (i.e. the value is null).	Fatal	FilingDateText	95. Date filed
B71	The value recorded for the element is a date greater than the current date or less than January 1, 2000.	Fatal	FilingDateText	95. Date filed
B72	The value recorded for the element is not a valid date in the format YYYYMMDD.	Fatal	FilingDateText	95. Date filed

7.3. Subject Information Errors

These errors can occur at the FinCEN SAR document level associated with the Part I Subject Information:

Code	Error Text	Severity	Associated Element(s)	Form Reference
C0	The party type associated with the subject is not recorded.	Fatal	Party	Subject Information
C1	The party type associated with the subject exceeds the maximum occurrence for the FinCEN SAR.	Fatal	Party	Subject Information
C2*	The element is not recorded for the subject and <AllCriticalSubjectInformationUnavailableIndicator> does not contain a "Y" value.	Warning	PartyName	4-7. Name
C3*	The element is not recorded or does not contain a value for the subject and unknown is not indicated.	Warning	RawEntityIndividualLastName	4. Name: Entity/Last
C4	The element is not recorded or does not contain a value for an individual subject and unknown is not indicated.	Warning	RawIndividualFirstName	5. Name: First
C5	The gender is not specified for the individual subject.	Warning	FemaleGenderIndicator MaleGenderIndicator UnknownGenderIndicator	08a-c. Gender
C6	More than one gender is recorded for the subject.	Warning	FemaleGenderIndicator MaleGenderIndicator UnknownGenderIndicator	08a-c. Gender
C53	A gender indicator element is recorded with a "Y" value for the entity subject.	Warning	FemaleGenderIndicator MaleGenderIndicator UnknownGenderIndicator PartyAsEntityOrganizationIndicator	08a-c. Gender 03a. Check if entity
C7	The element is not recorded for the subject and <AllCriticalSubjectInformationUnavailableIndicator> does not contain a "Y" value.	Warning	Address	11-15. Address
C8	The element is not recorded or does not contain a value and unknown is not indicated.	Warning	RawStreetAddress1Text	11. Address: Street
C9	The element is not recorded or does not contain a value and unknown is not indicated.	Warning	RawCityText	12. Address: City
C10	The element contains an invalid state code.	Fatal	RawStateCodeText	13. Address: State
C11	The element is not recorded or does not contain a value when the	Warning	RawStateCodeText	13. Address: State

Code	Error Text	Severity	Associated Element(s)	Form Reference
	country is US, CA, or MX, and unknown is not indicated.			
C12	The element contains a value and the country is not US, CA, MX, or a U.S. Territory.	Warning	RawStateCodeText	13. Address: State
C13	State code and country code mismatch when a U.S. Territory is recorded.	Warning	RawCountryCodeText RawStateCodeText	13, 15. Address: State, Country
C14	The value recorded contains punctuation or formatting.	Fatal	RawZIPCode	14. Address: ZIP/Postal Code
C15	The element is not recorded or does not contain a value and unknown is not indicated.	Warning	RawZIPCode	14. Address: ZIP/Postal Code
C16	The value recorded is not equal to 5 or 9 numeric characters, is a 9-digit value ending in four zeros or four nines, and the corresponding country is equal to US or a U.S. Territory code.	Warning	RawZIPCode	14. Address: ZIP/Postal Code
C17	The element contains an invalid country code.	Fatal	RawCountryCodeText	15. Address: Country
C18	The element is not recorded or does not contain a value and unknown is not indicated.	Warning	RawCountryCodeText	15. Address: Country
C19*	The element is not recorded for the subject TIN and <AllCriticalSubjectInformationUnavailableIndicator> does not contain a "Y" value.	Warning	PartyIdentification	16-17. TIN
C20	The element is not recorded or does not contain a value and unknown is not indicated.	Fatal	PartyIdentificationNumberText	16. TIN: Number
C21*	The value recorded for the EIN or SSN/ITIN is an invalid number string.	Warning	PartyIdentificationNumberText	16. TIN: Number
C54	The element is not recorded or does not contain a valid value.	Fatal	PartyIdentificationTypeCode	17. TIN: Type
C22	The element is not recorded or does not contain a value for the subject Form of Identification and <AllCriticalSubjectInformationUnavailableIndicator> does not contain a "Y" value.	Warning	PartyIdentification	18. Form of ID
C23	The element contains a value and unknown is indicated.	Warning	PartyIdentificationNumberText	18e. Form of ID: Number
C24	The value recorded for the form of identification number is an invalid number string.	Warning	PartyIdentificationNumberText	18e. Form of ID: Number
C25	The element is not recorded or does not contain a value, the form of identification is Driver's license/State ID, and the country code is US, CA, MX, or a U.S. Territory.	Warning	OtherIssuerStateText	18f. Form of ID: Issuing State
C26	The element contains a value and identification unknown is indicated.	Warning	OtherIssuerStateText	18f. Form of ID: Issuing State
C27	The element contains an invalid state code.	Warning	OtherIssuerStateText	18f. Form of ID: Issuing State
C28	State code and country code mismatch when U.S. Territory is recorded.	Warning	OtherIssuerCountryText OtherIssuerStateText	18f,g. Form of ID: Issuing State/Country

Code	Error Text	Severity	Associated Element(s)	Form Reference
C29	The element is not recorded or does not contain a value and the form of identification is Passport or Alien registration.	Warning	OtherIssuerCountryText	18g. Form of ID: Issuing Country
C30	The element contains a value and identification unknown is indicated.	Warning	OtherIssuerCountryText	18g. Form of ID: Issuing Country
C31	The element contains an invalid country code.	Warning	OtherIssuerCountryText	18g. Form of ID: Issuing Country
C32	The element is not recorded or does not contain a value and the form of identification is Other.	Warning	OtherPartyIdentificationTypeText	18z. Form of ID: Type - Other Description
C33	The element contains a value and identification unknown is indicated.	Warning	OtherPartyIdentificationTypeText	18z. Form of ID: Type - Other Description
C34	The value recorded for the element is not in the required format (YYYYMMDD).	Warning	IndividualBirthDateText	19. Date of birth: Date
C35	The element is not recorded for the individual subject and <AllCriticalSubjectInformationUnavailableIndicator> and <BirthDateUnknownIndicator> do not contain a "Y" value.	Warning	IndividualBirthDateText	19. Date of birth: Date
C36	The date of birth recorded is less than January 1, 1900.	Warning	IndividualBirthDateText	19. Date of birth: Date
C37	The element contains an invalid code.	Fatal	PhoneNumberTypeCode	20a-d. Phone: Type (a. Home, b. Work, c. Mobile, d. Fax)
C38	The value recorded for the element is not a valid email address or URL format.	Warning	ElectronicAddressText	22,22a. E-Address: Address
C39	The element is not recorded or does not contain a value (i.e. the value is null).	Fatal	ElectronicAddressTypeCode	22,22a. E-Address: Type Indicator
C40	The element contains an invalid code.	Fatal	ElectronicAddressTypeCode	22,22a. E-Address: Type Indicator
C41*	The element is not recorded or at least one indicator identifying the type of relationship is not recorded with a "Y" value.	Warning	PartyAssociation	24. Subject Relationship to FI (relationship type indicators)
C42	The value recorded does not match the TIN for the filing institution or a financial institution where the activity occurred.	Fatal	SubjectRelationshipFinancialInstitutionTINText	24a. Subject Relationship to FI: Institution TIN
C43	The element is not recorded or does not contain a value and Other is indicated.	Warning	OtherPartyAssociationTypeText	24z. Subject Relationship to FI: Other description
C44	The element is recorded with a value and Other is not indicated.	Warning	OtherPartyAssociationTypeText	24z. Subject Relationship to FI: Other description
C45	The element is not recorded or does not contain a value and the status of the relationship is Terminated, Suspended/barred, or Resigned.	Warning	ActionTakenDateText	26. Subject Relationship to FI: Action date
C46	The value recorded for the element is not in the required format (YYYYMMDD).	Warning	ActionTakenDateText	26. Subject Relationship to FI: Action date
C55	The element is recorded with a valid value but the status of the relationship is not equal to	Warning	ActionTakenDateText	26. Subject Relationship to FI: Action date

Code	Error Text	Severity	Associated Element(s)	Form Reference
	Terminated, Suspended/barred, or Resigned.			
C56	The element is recorded with a valid value but the type of relationship is not equal to Director, Employee, Officer, or Owner/Controlling Shareholder.	Warning	RelationshipContinuesIndicator; ResignedIndicator; SuspendedBarredIndicator; TerminatedIndicator	25. Subject Relationship to FI: Status of relationship
C57	The element is not recorded or does not contain a value and the type of relationship is equal to Director, Employee, Officer, and/or Owner/Controlling Shareholder.	Warning	RelationshipContinuesIndicator; ResignedIndicator; SuspendedBarredIndicator; TerminatedIndicator	25. Subject Relationship to FI: Status of relationship
C47	The NoKnownAccountInvolvedIndicator element is recorded with a "Y" value but the PartyAccountAssociation element is also recorded.	Warning	NoKnownAccountInvolvedIndicator PartyAccountAssociation Account	27. Related FI TIN/Account(s)/No known accounts involved
C48	The NoKnownAccountInvolvedIndicator element is not recorded and the PartyAccountAssociation element is also not recorded.	Warning	NoKnownAccountInvolvedIndicator PartyAccountAssociation Account	27. Related FI TIN/Account(s)/No known accounts involved
C49	The element is not recorded or does not contain a value.	Fatal	PartyAccountAssociationType Code	27. Account: Party Association Type (Subject Identifier)
C50	The element contains an invalid code.	Fatal	PartyAccountAssociationType Code	27. Account: Party Association Type (Subject Identifier)
C51	More than one role is recorded for the subject.	Warning	BothPurchaserSenderPayeeReceiveIndicator PayeeReceiverIndicator PurchaserSenderIndicator	28a-c. Subject role in transaction
C52*	Subject relationship to institution is categorized as Director, Employee, Officer, and/or Owner/Controlling Shareholder, and Joint report is indicated.	Warning	ActivityAssociation (DirectorIndicator, EmployeeIndicator, OfficerIndicator, OwnerShareholderIndicator); PartyAssociation (JointReportIndicator)	24h/i/k/l. Subject relationship to institution; 1d. Joint report

7.4. Financial Institution & Branch Where Activity Occurred Errors

These errors can occur at the FinCEN SAR document level associated with the Part III Financial Institution Where Activity Occurred Information, as well as the Branch location (if any):

Code	Error Text	Severity	Associated Element(s)	Form Reference
D0	The party type associated with the financial institution where activity occurred is not recorded.	Fatal	Party	FI Where Activity Occurred
D1	The party type associated with the financial institution where activity occurred exceeds the maximum occurrence for the FinCEN SAR.	Fatal	Party	FI Where Activity Occurred
D2	The element is not recorded.	Fatal	OrganizationClassificationType Subtype	51, 53-54. Institution Type/Subtype

Code	Error Text	Severity	Associated Element(s)	Form Reference
D3	The element is not recorded or does not contain a value (i.e. the value is null).	Fatal	OrganizationTypeID	51a-g,z. Institution Type
D4	The element contains an invalid code.	Fatal	OrganizationTypeID	51a-g,z. Institution Type
D5	The element is not recorded or does not contain a value and the institution type is equal to Other.	Warning	OtherOrganizationTypeText	51z. Institution Type Other Description
D6	The element is recorded with a value but the institution type is not equal to Other.	Warning	OtherOrganizationTypeText	51z. Institution Type Other Description
D7	The element is not recorded.	Fatal	PrimaryRegulatorTypeCode	52a-i. Primary Federal Regulator
D8	The element is recorded but with no value (i.e. the value is null).	Fatal	PrimaryRegulatorTypeCode	52a-i. Primary Federal Regulator
D9	The element contains an invalid code.	Fatal	PrimaryRegulatorTypeCode	52a-i. Primary Federal Regulator
D10	The element is not recorded or does not contain a value (i.e. the value is null) and the institution type is equal to Casino/Card club or Securities and Futures.	Fatal	OrganizationSubtypeID	53a-c,z 54a-k,z. Institution Subtype: Gaming Institution, Institution Subtype: Securities/Futures Institution
D11	The element contains an invalid code.	Fatal	OrganizationSubtypeID	53a-c,z 54a-k,z. Institution Subtype: Gaming Institution, Institution Subtype: Securities/Futures Institution
D12	The element contains a value but the institution type is not equal to Casino/Card club or Securities and Futures.	Fatal	OrganizationSubtypeID	53a-c,z 54a-k,z. Institution Subtype: Gaming Institution, Institution Subtype: Securities/Futures Institution
D14	The value recorded conflicts with the institution type recorded (e.g. State Casino recorded for Securities and Futures institution)	Fatal	OrganizationSubtypeID	53a-c,z 54a-k,z. Institution Subtype: Gaming Institution, Institution Subtype: Securities/Futures Institution
D15	The element is not recorded or does not contain a value and the institution subtype is equal to Other.	Warning	OtherOrganizationSubTypeText	53z 54z. Institution Subtype Other: Gaming Institution Description Institution Subtype Other: Securities/Futures Institution Description
D16	The element is recorded with a value but the institution subtype is not equal to Other.	Warning	OtherOrganizationSubTypeText	53z 54z. Institution Subtype Other: Gaming Institution Description Institution Subtype Other:

Code	Error Text	Severity	Associated Element(s)	Form Reference
				Securities/Futures Institution Description
D17	The element is not recorded or does not contain a value and unknown is not indicated.	Fatal	PartyIdentificationNumberText	55h. Institution ID: Number
D51	More than one role is recorded for the financial institution's role in transaction.	Warning	PayLocationIndicator SellingLocationIndicator SellingPayingLocationIndicator	56a-b. Role in transaction
D18	The element is not recorded or does not contain a value and unknown is not indicated.	Fatal	RawPartyFullName	57. Name: Legal name of FI
D19	The element is recorded with a value for the legal name and unknown is indicated.	Warning	RawPartyFullName	57. Name: Legal name of FI
D20	The element is not recorded or does not contain a value and unknown is not indicated.	Fatal	PartyIdentificationNumberText	59. TIN: Number
D21*	The value recorded for the EIN or SSN/ITIN is an invalid number string.	Warning	PartyIdentificationNumberText	59. TIN: Number
D52	The element is not recorded or does not contain a valid value.	Fatal	PartyIdentificationTypeCode	60. TIN: Type
D22	The element is not recorded or does not contain a value and unknown is not indicated.	Warning	RawStreetAddress1Text	61. Address: Address/Street
D23	The element is not recorded or does not contain a value and unknown is not indicated.	Warning	RawCityText	62. Address: City
D24	The element contains an invalid state code.	Fatal	RawStateCodeText	63. Address: State
D25	The element is not recorded or does not contain a value when the country is US, CA, MX, or a U.S. Territory.	Warning	RawStateCodeText	63. Address: State
D26	The element contains a value and the country is not US, CA, MX, or a U.S. Territory.	Warning	RawStateCodeText	63. Address: State
D27	State code and country code mismatch when U.S. Territory is recorded.	Warning	RawCountryCodeText RawStateCodeText	63, 65. Address: State, Country
D28	The value recorded contains punctuation or formatting.	Fatal	RawZIPCode	64. Address: ZIP/Postal Code
D29	The element is not recorded or does not contain a value and unknown is not indicated.	Warning	RawZIPCode	64. Address: ZIP/Postal Code
D30	The value recorded is not equal to 5 or 9 numeric characters, is a 9-digit value ending in four zeros or four nines, and the corresponding country is equal to US or a U.S. Territory code.	Warning	RawZIPCode	64. Address: ZIP/Postal Code
D31	The element contains an invalid country code.	Fatal	RawCountryCodeText	65. Address: Country
D32	The element is not recorded or does not contain a value and unknown is not indicated.	Warning	RawCountryCodeText	65. Address: Country
D33	The loss to financial institution amount recorded contains one or more non-numeric characters.	Warning	LossToFinancialAmountText	67. Loss to financial institution (amount)

Code	Error Text	Severity	Associated Element(s)	Form Reference
D53	The loss to financial institution amount recorded is equal to zero.	Warning	LossToFinancialAmountText	67. Loss to financial institution (amount)
D34	The loss to financial institution amount recorded is greater than the amount recorded for <TotalSuspiciousAmountText>	Warning	LossToFinancialAmountText	67. Loss to financial institution (amount)
D35	The element is recorded but no relationship indicator is recorded with a "Y" value.	Warning	PartyAssociation	67. FI/Branch Party Association
D36	This element is recorded with a "Y" value for the Financial institution (34) but one or more Branch (46) party type locations are also recorded.	Warning	NoBranchActivityInvolvedIndicator	69a. No branch activity involved indicator
D37	The party type associated with the branch where activity occurred is not recorded and "no branch activity involved" is not indicated.	Warning	Party	Branch Location
D38	The party type associated with the branch where activity occurred exceeds the maximum occurrence for the FinCEN SAR.	Fatal	Party	Branch Location
D39	More than one role is recorded for the branch's role in the transaction.	Warning	PayLocationIndicator SellingLocationIndicator SellingPayingLocationIndicator	68a-c. Role in transaction
D41	The element is not recorded for the Branch and <NoBranchActivityInvolvedIndicator> does not contain a "Y" value.	Warning	Address	69, 71-74. Address
D44	The element contains an invalid state code.	Fatal	RawStateCodeText	72. Address: State
D45	The element contains a value and the country is not US, CA, MX, or a U.S. Territory.	Warning	RawStateCodeText	72. Address: State
D46	The element is not recorded or does not contain a value when the country is a U.S. Territory.	Warning	RawStateCodeText	72. Address: State
D47	State code and country code mismatch when U.S. Territory is recorded.	Warning	RawCountryCodeText RawStateCodeText	72, 74. Address: State, Country
D49	The element contains an invalid country code.	Fatal	RawCountryCodeText	74. Address: Country
D50	The element is not recorded or does not contain a value.	Warning	RawCountryCodeText	74. Address: Country

7.5. Filing Institution Errors

These errors can occur at the FinCEN SAR document level associated with the Part IV Filing Institution Information:

Code	Error Text	Severity	Associated Element(s)	Form Reference
E0	The party type associated with the filing institution is not recorded.	Fatal	Party	Filing Institution

Code	Error Text	Severity	Associated Element(s)	Form Reference
E1	The party type associated with the filing institution exceeds the maximum occurrence for the FinCEN SAR.	Fatal	Party	Filing Institution
E2	The element is not recorded.	Fatal	PrimaryRegulatorTypeCode	75a-i, z. Primary Federal Regulator
E3	The element is recorded but with no value (i.e. the value is null).	Fatal	PrimaryRegulatorTypeCode	75a-i, z. Primary Federal Regulator
E4	The element contains an invalid code.	Fatal	PrimaryRegulatorTypeCode	75a-i, z. Primary Federal Regulator
E5*	The element is not recorded.	Warning	RawPartyFullName	76. Name: Legal name
E6*	The element is recorded but with no value (i.e. the value is null).	Warning	RawPartyFullName	76. Name: Legal name
E7	The element is not recorded or does not contain a value for the filing institution TIN.	Fatal	PartyIdentificationNumberText	77. TIN: Number
E9*	The value recorded for the EIN or SSN/ITIN is an invalid number string.	Warning	PartyIdentificationNumberText	77. TIN: Number
E46	The element is not recorded or does not contain a valid value.	Fatal	PartyIdentificationTypeCode	78. TIN: Type
E10	The element is not recorded.	Fatal	OrganizationClassificationTypeSubtype	79, 80. Institution Type/Subtype
E11	The element is not recorded or does not contain a value (i.e. the value is null).	Fatal	OrganizationTypeID	79a-g,z. Institution Type
E12	The element contains an invalid code.	Fatal	OrganizationTypeID	79a-g,z. Institution Type
E13	The element is not recorded or does not contain a value and the institution type is equal to Other.	Warning	OtherOrganizationTypeText	79z. Institution Type Other Description
E14	The element is recorded with a value but the institution type is not equal to Other.	Warning	OtherOrganizationTypeText	79z. Institution Type Other Description
E15	The element is not recorded or does not contain a value (i.e. the value is null) and the institution type is equal to Securities and Futures.	Fatal	OrganizationSubTypeID	80a-n,z. Institution Subtype: Securities/Futures Institution
E16	The element contains an invalid code.	Fatal	OrganizationSubTypeID	80a-n,z. Institution Subtype: Securities/Futures Institution
E17	The element contains a value but the institution type is not equal to Securities and Futures.	Fatal	OrganizationSubTypeID	80a-n,z. Institution Subtype: Securities/Futures Institution
E19	The value recorded conflicts with the institution type recorded (e.g. State Casino recorded for Securities and Futures institution)	Fatal	OrganizationSubTypeID	80a-n,z. Institution Subtype: Securities/Futures Institution
E20	The element is recorded with a value but the institution subtype is not equal to Other.	Warning	OtherOrganizationSubTypeText	80z. Institution Subtype Other: Securities/Futures Institution Description
E47	The element is not recorded or does not contain a value and the institution subtype is equal to Other.	Warning	OtherOrganizationSubTypeText	80z. Institution Subtype Other: Securities/Futures Institution Description
E21	The element is not recorded or does not contain a value for the filing institution identification number.	Fatal	PartyIdentificationNumberText	81h. Institution ID: Number
E22	The value recorded for the identification number is an invalid number string.	Warning	PartyIdentificationNumberText	81h. Institution ID: Number

Code	Error Text	Severity	Associated Element(s)	Form Reference
E24	The element is not recorded or does not contain a value for the filing institution.	Warning	RawStreetAddress1Text	82. Address: Address/Street
E26	The element is not recorded or does not contain a value for the filing institution.	Warning	RawCityText	83. Address: City
E27	The element contains an invalid state code.	Fatal	RawStateCodeText	84. Address: State
E28	The element is not recorded or does not contain a value for the filing institution when the country is US, CA, MX, or a U.S. Territory.	Warning	RawStateCodeText	84. Address: State
E30	The element contains a value and the country is not US, CA, MX, or a U.S. Territory.	Warning	RawStateCodeText	84. Address: State
E31	State code and country code mismatch when U.S. Territory is recorded.	Warning	RawCountryCodeText RawStateCodeText	8486. Address
E32	The value recorded contains punctuation or formatting.	Fatal	RawZIPCode	85. Address: ZIP/Postal Code
E34	The element is not recorded or does not contain a value for the filing institution.	Warning	RawZIPCode	85. Address: ZIP/Postal Code
E35	The value recorded is not equal to 5 or 9 numeric characters, is a 9-digit value ending in four zeros or four nines, and the corresponding country is equal to US or a U.S. Territory code.	Warning	RawZIPCode	85. Address: ZIP/Postal Code
E36	The element contains an invalid country code.	Fatal	RawCountryCodeText	86. Address: Country
E37	The element is not recorded or does not contain a value for the filing institution.	Warning	RawCountryCodeText	86. Address: Country
E39	The party type associated with the designated contact office is not recorded.	Fatal	Party	93. Designated Contact Office
E40	The party type associated with the designated contact office exceeds the maximum occurrence for the FinCEN SAR.	Fatal	Party	93. Designated Contact Office
E41	The element is not recorded or does not contain a value for the Designated contact office.	Fatal	RawPartyFullName	93. Name: Legal name
E42	The element is not recorded or does not contain a value for the designated contact office.	Warning	PhoneNumberText	94. Phone: Number
E43	The party type associated with the LE contact agency exceeds the maximum occurrence for the FinCEN SAR.	Fatal	Party	89. LE Contact Agency
E44	The party type associated with the LE contact name exceeds the maximum occurrence for the FinCEN SAR.	Fatal	Party	90. LE Contact Name
E45	The value recorded for the element is not in the required format (YYYYMMDD).	Fatal	ContactDateText	92. LE contact date

7.6. Attachment & Narrative Errors

These errors can occur at the FinCEN SAR document level associated with the Part V Attachment & Narrative Information:

Code	Error Text	Severity	Associated Element(s)	Form Reference
F0	The batch submission contains an attachment but the <OriginalAttachmentFileName> element is not recorded or does not contain a value.	Fatal	OriginalAttachmentFileName	FinCEN SAR Attachment
F1	The element is recorded with a valid value but there is no corresponding attachment.	Fatal	OriginalAttachmentFileName	FinCEN SAR Attachment
F2	The element is not recorded.	Fatal	ActivityNarrativeInformation	Narrative
F3	The element is not recorded or does not contain a value.	Fatal	ActivityNarrativeSequenceNumber	Narrative: Sequence Number
F4	The element contains an invalid code.	Fatal	ActivityNarrativeSequenceNumber	Narrative: Sequence Number
F5	The element is not recorded or does not contain a value.	Fatal	ActivityNarrativeText	Narrative: Value/Description

7.7. Transmitter Errors

These errors can occur at the FinCEN SAR document level associated with Transmitter of the batch:

Code	Error Text	Severity	Associated Element(s)	Form Reference
G0	A required party associated with the transmitter is missing.	Fatal	Party	NA
G1	The report contains more than one party associated with the transmitter.	Fatal	Party	NA
G2	The element is not recorded or does not contain a value	Warning	Transmitter Name	NA
G3	The element is not recorded or does not contain a value	Warning	Transmitter Address	NA
G4	The element is not recorded or does not contain a value	Warning	Transmitter City	NA
G5	The element is not recorded or does not contain a value and unknown is not indicated.	Warning	Transmitter State	NA
G6	The element contains a value that is not a valid code	Warning	Transmitter State	NA
G7	The element is not recorded or does not contain a value	Warning	Transmitter ZIP/Postal Code	NA
G8	The value recorded contains one or more non-numeric characters or is in an invalid format and the country is US	Warning	Transmitter ZIP/Postal Code	NA
G9	The element is not recorded or does not contain a value	Warning	Transmitter Country	NA
G10	The element contains a value that is not a valid code	Warning	Transmitter Country	NA
G11	State code and country code mismatch when U.S. Territory is recorded	Warning	Transmitter Country	NA
G12	The element contains an invalid number string for a US TIN	Warning	Transmitter Taxpayer Identification Number (TIN)	NA
G13	The element is not recorded or does not contain a value	Warning	Transmitter Taxpayer Identification Number (TIN)	NA

Code	Error Text	Severity	Associated Element(s)	Form Reference
G14	The element is recorded but without a value (i.e. the value is null).	Fatal	Transmitter Taxpayer Identification Number (TIN) or Control Code (TCC) Type	NA
G15	The element contains a value that is not a valid code	Fatal	Transmitter Taxpayer Identification Number (TIN) or Control Coe (TCC) Type	NA
G16	The Transmitter Control Code (TCC) specified in the file is not a valid TCC. For production, the TCC must begin with "P" and for User Test, it must be equal to "TBSATEST".	Fatal	Transmitter Control Code (TCC) Number	NA
G19	The value recorded for the element contains non-numeric characters	Warning	Transmitter Telephone Number	NA
G20	The element is not recorded or does not contain a value (i.e. the value is null).	Warning	Transmitter Telephone Number	NA

7.8. Transmitter Contact Errors

These errors can occur at the FinCEN SAR document level associated with contact person for the Transmitter of the batch:

Code	Error Text	Severity	Associated Element(s)	Form Reference
H0	A required party associated with the transmitter contact is missing.	Fatal	Party	NA
H1	The report contains more than one party associated with the transmitter contact.	Fatal	Party	NA
H2	The element is not recorded or does not contain a value	Warning	Transmitter Contact Name	NA

8. Attachment B – Error Correction Instructions

This attachment identifies the requirements and procedures for correcting FinCEN SAR errors reported to batch filers during the FinCEN SAR acknowledgement process.

Error Categories:

There are two main categories of errors identified in batch files: Schema validation errors that result in automatic rejection of the batch file and data errors that represent errors in data entered for individual elements but may not result in a rejection.

Schema validation errors prevent the batch file from being processed and are considered fatal errors. An example of a schema validation error is a missing required element or an element sequence that does not match the schema. An example of a data error is a required element that contains no value. Data errors are classified as primary or secondary warnings, depending on their importance. Primary warnings are file errors that violate electronic filing requirements or instructions and so degrade FinCEN SAR data quality that they must be corrected. Primary warnings make it difficult for regulators, analysts, and law enforcement investigators to locate the FinCEN SARs in the database or identify the nature and circumstances of the suspicious activity. Examples of such warnings include blank last names or legal names, missing financial institution Employer Identification Numbers, or an invalid entry in the suspicious activity date field. Attachment A – Error Descriptions identifies primary errors by adding an asterisk (*) to the error code.

Secondary warnings are data errors that violate electronic filing requirements or instructions but have a lesser impact on FinCEN SAR data quality. Examples of secondary errors are ZIP Codes that end in four zeros (e.g. 123450000), missing dates of birth, or invalid telephone numbers.

Correction Requirements:

Filers should immediately correct and resubmit a batch file rejected for fatal errors when notified by FinCEN the batch file was not accepted.

When an accepted batch file contains FinCEN SARs with primary warning errors, those FinCEN SARs must be re-filed as a corrected report with the primary errors and any secondary errors corrected. FinCEN SARs that contain only secondary errors need not be corrected. FinCEN requires that filers prevent all reported errors in their future filings. FinCEN recommends that data error corrections be made no later than 30 days after receiving error notifications. Furthermore, FinCEN recommends that filers remedy any systemic problems in their electronic submissions within 30 days of receiving error notifications. If technical issues prevent filers from implementing corrections within these time frames, filers should notify FinCEN by writing to:

Financial Crimes Enforcement Network
Office of Domestic Liaison
Data Quality Assessments
P.O. Box 39
Vienna, VA 22183

This correspondence should explain the technical issues involved that prevent meeting the time frame, provide an estimate of when the issues will be resolved, and include a contact name and telephone number.

Correction Procedures:

FinCEN SAR batch files are rejected when they contain fatal format errors. Filers must correct all fatal errors identified in the batch file and resubmit the batch file to BSA E-Filing. Because they were not accepted by FinCEN, initial report FinCEN SARs in the re-submitted batch file are still initial reports. Do not identify FinCEN SARs from a rejected batch file as Amended reports unless they originally were filed as Amended reports.

If errors involve accepted with warning errors in the FinCEN SARs of an accepted batch file, filers should correct all errors and file amended reports on the affected FinCEN SARs using the following procedures:

- Make the corrections to all errors in the FinCEN SARs in the accepted batch file.

- Record "Y" in the <CorrectsAmendsPriorReportIndicator> element under the <Activity Association> element in each FinCEN SAR to be corrected.
- Record in the <EFilingPriorDocumentNumber> element under the <Activity> element the BSA Identifier (from the FinCEN SAR Acknowledgement) that was assigned to the FinCEN SAR being corrected.
- Ensure that the <FilingDateText> element contains a new date.
- Complete all other data in the FinCEN SAR in their entirety.
- Retransmit the corrected FinCEN SAR in a new batch file. Do not re-transmit the original batch file because this will cause duplicate database entries on any FinCEN SARs that were not corrected.

9. Attachment C – Electronic XML Filing Instructions

Safe Harbor: Federal law (31 U.S.C. 5318(g)(3)) provides financial institutions complete protection from civil liability for all reports of suspicious transactions made to appropriate authorities, including supporting documentation, regardless of whether such reports are filed pursuant to a regulatory requirement or on a voluntary basis. Specifically, the law provides that a financial institution, and its directors, officers, employees, and agents, that make a disclosure of any possible violation of law or regulation, including in connection with the preparation of suspicious activity reports, “shall not be liable to any person under any law or regulation of the United States, any constitution, law, or regulation of any State or political subdivision of any State, or under any contract or other legally enforceable agreement (including any arbitration agreement), for such disclosure or for any failure to provide notice of such disclosure to the person who is the subject of such disclosure or any other person identified in the disclosure.”

9.1. Confidentiality of FinCEN SARs:

A FinCEN Suspicious Activity Report (FinCEN SAR), and any information that would reveal the existence of the FinCEN SAR (collectively, “FinCEN SAR information”), is confidential, and may not be disclosed except as specified in 31 U.S.C. 5318(g)(2) and in FinCEN’s regulations (31 CFR Chapter X).

9.2. FinCEN SAR Sharing:

FinCEN, the Federal Banking Regulators, the Securities and Exchange Commission (SEC), and the Commodity Futures Trading Commission (CFTC) have concluded that any depository institution, broker-dealer in securities, futures commission merchant, and introducing broker in commodities may share the FinCEN SAR, or any information that would reveal the existence of the FinCEN SAR, with its head office or parent entity (whether domestic or foreign). (See “Interagency Guidance on Sharing Suspicious Activity Reports with Head Offices and Controlling Companies,” January 20, 2006 and “Guidance on Sharing of Suspicious Activity Reports by Securities Broker-Dealers, Futures Commission Merchants, and Introducing Brokers in Commodities,” January 20, 2006.)

In addition, any depository institution, broker-dealer in securities, futures commission merchant, introducing broker in commodities, or casino that has filed a FinCEN SAR may share the FinCEN SAR, or any information that would reveal the existence of the FinCEN SAR, with an affiliate, as defined in FinCEN guidance (respectively, FIN-2010-G006 “Sharing Suspicious Activity Reports by Depository Institutions with Certain U.S. Affiliates,” Nov. 23, 2010; FIN-2010-G005, “Sharing Suspicious Activity Reports by Securities Broker-Dealers, Mutual Funds, Futures Commission Merchants, and Introducing Brokers in Commodities with Certain U.S. Affiliates;” FIN-2017-G001, “Sharing Suspicious Activity Reports with U.S. Parents and Affiliates of Casinos,” January 4, 2017), provided the affiliate is subject to a FinCEN SAR regulation. The sharing of FinCEN SARs with head offices and affiliates facilitates the identification of suspicious transactions taking place through the depository institution’s affiliates that are subject to a FinCEN SAR rule. Therefore, such sharing within the depository institution’s corporate organizational structure is consistent with the purposes of Title II of the BSA.

9.3. Prohibition on Disclosures by Financial Institutions:

Federal law (31 U.S.C. 5318(g)(2)) provides that a financial institution, and its directors, officers, employees, and agents who, pursuant to any statutory or regulatory authority or on a voluntary basis, report suspicious transactions to the government, may not notify any person involved in the transaction that the transaction has been reported. Provided that no person involved in the suspicious activity is notified, 31 CFR Chapter X clarifies that the following activity does not constitute a prohibited disclosure:

- Disclosure of FinCEN SAR information to certain governmental authorities or other examining authorities that are otherwise entitled by law to receive FinCEN SAR information or to examine for or investigate suspicious activity;
- Disclosure of the underlying facts, transactions, and documents upon which a FinCEN SAR is based; and
- For those institutions regulated by a federal functional regulator (federal bank regulatory agencies, the SEC, and the CFTC), the sharing of FinCEN SAR information within an institution’s corporate organizational

structure, for purposes that are consistent with the Bank Secrecy Act, as determined by regulation or guidance.

9.4. Prohibition on Disclosures by Government Authorities:

Federal law (31 U.S.C. 5318(g)(2)) also provides that an officer or employee of any Federal, state, local, tribal, or territorial government within the United States who has knowledge that such report was made, may not disclose to any person involved in the transaction that the transaction has been reported, other than as necessary to fulfill the official duties of such officer or employee. FinCEN's regulations clarify that "official duties" must be consistent with Title II of the Bank Secrecy Act and shall not include the disclosure of a FinCEN SAR, or any information that would reveal the existence of a FinCEN SAR, in response to a request for disclosure of non-public information or a request for use in a private legal proceeding, including a request pursuant to 31 CFR § 1.111.

9.5. FinCEN SAR Filing Instructions:

1. Who Must File: Certain financial institutions operating in the United States shall file with FinCEN, to the extent and in the manner required by 31 CFR Chapter X and 12 CFR §§ 21.11, 163.180, 208.62, 353.3, and 748.1, a report of any suspicious transaction relevant to a possible violation of law or regulation. The following financial institutions are required to file a FinCEN SAR: Banks (31 CFR §1020.320) including Bank and Financial Holding Companies (12 CFR § 225.4); Casinos and Card Clubs (31 CFR § 1021.320); Money Services Businesses (31 CFR § 1022.320); Brokers or Dealers in Securities (31 CFR § 1023.320); Mutual Funds (31 CFR § 1024.320); Insurance Companies (31 CFR § 1025.320); Futures Commission Merchants and Introducing Brokers in Commodities (31 CFR § 1026.320); Residential Mortgage Lenders and Originators (31 CFR § 1029.320), and Housing Government Sponsored Enterprises (31 CFR § 1030.320).

2. Filing Deadlines: A FinCEN SAR shall be filed no later than 30 calendar days after the date of the initial detection by the reporting financial institution of facts that may constitute a basis for filing a report. If no suspect is identified on the date of such initial detection, a financial institution may delay filing a FinCEN SAR for an additional 30 calendar days to identify a suspect, but in no case shall reporting be delayed more than 60 calendar days after the date of such initial detection. In situations involving violations that require immediate attention, such as terrorist financing or ongoing money laundering schemes, the financial institution shall immediately notify by telephone an appropriate law enforcement authority in addition to filing timely a FinCEN SAR. Financial institutions wishing voluntarily to report suspicious transactions that may relate to terrorist activity may call FinCEN's Financial Institutions Hotline at 1-866-556-3974 in addition to filing timely a FinCEN SAR.

3. Filing Requirements for Financial Institutions: A financial institution must report any transaction that requires reporting under the terms of 31 CFR Chapter X if the transaction is conducted or attempted by, at, or through the financial institution and involves or aggregates at least \$5,000 (\$2,000 for money services businesses, except as provided in Section 6 of this document) and the financial institution knows, suspects, or has reason to suspect that the transaction or pattern of transactions of which the transaction is a part:

- Involves funds derived from illegal activity or is intended or conducted in order to hide or disguise funds or assets derived from illegal activity (including, without limitation, the ownership, nature, source, location, or control of such funds or assets) as part of a plan to violate or evade any Federal law or regulation or to avoid any transaction reporting requirement under Federal law or regulation;
- Is designed, whether through structuring or other means, to evade any requirement of 31 CFR Chapter X or any other regulation promulgated under the Bank Secrecy Act, Public Law 91-508, as amended, codified at 12 U.S.C 1829b, 12 U.S.C. 1951-1959, and 31 U.S.C. 5311-5332.
- Has no business or apparent lawful purpose or is not the sort in which the particular customer would normally be expected to engage, and the financial institution knows of no reasonable explanation for the transaction after examining the available facts, including the background and possible purpose of the transaction, or
- Involves the use of the financial institution to facilitate criminal activity.

4. Additional Filing Instructions for Banks: In addition to the above requirements, a bank (as defined in 31 CFR § 1010.100) must file a FinCEN SAR for activity (as required by 31 CFR § 1020.320 and 12 CFR §§ 21.11, 163.180, 208.62, 353.3, and 748.1) involving:

- **Insider abuse involving any amount.** Whenever the bank detects any known or suspected Federal criminal violations, or pattern of criminal violations, committed or attempted against the financial institution or involving a transaction or transactions conducted through the financial institution, where the bank believes that it was either an actual or potential victim of a criminal violation, or series of criminal violations, or that the bank was used to facilitate a criminal transaction, and the bank has a substantial basis for identifying one of its directors, officers, employees, agents or other institution-affiliated parties as having committed or aided in the commission of a criminal act regardless of the amount involved in the violation.
- **Violations aggregating \$5,000 or more where a suspect can be identified.** Whenever the bank detects any known or suspected Federal criminal violation, or pattern of criminal violations, committed or attempted against the bank or involving a transaction or transactions conducted through the bank and involving or aggregating \$5,000 or more in funds or other assets, where the bank believes that it was either an actual or potential victim of a criminal violation, or series of criminal violations, or that the bank was used to facilitate a criminal transaction, and the bank has a substantial basis for identifying a possible suspect or group of suspects. If it is determined prior to filing this report that the identified suspect or group of suspects has used an "alias," then information regarding the true identity of the suspect or group of suspects, as well as alias identifiers, such as drivers' licenses or social security numbers, addresses and telephone numbers, must be reported.
- **Violations aggregating \$25,000 or more regardless of a potential suspect.** Whenever the bank detects any known or suspected Federal criminal violation, or pattern of criminal violations, committed or attempted against the bank or involving a transaction or transactions conducted through the bank and involving or aggregating \$25,000 or more in funds or other assets, where the bank believes that it was either an actual or potential victim of a criminal violation, or series of criminal violations, or that the bank was used to facilitate a criminal transaction, even though there is no substantial basis for identifying a possible suspect or group of suspects.

5. Voluntary FinCEN SAR Filings: Financial institutions may also file with FinCEN a report of any suspicious transaction that it believes is relevant to the possible violation of any law or regulation but whose reporting is not required by 31 CFR Chapter X. A voluntary filing does not relieve a financial institution from the responsibility of complying with any other reporting requirements imposed by the SEC, the CFTC, a self-regulatory organization (SRO) (as defined in section 3(a)(26) of the Securities Exchange Act of 1934, 15 U.S.C. 78c (a)(26)), or any Registered Futures Association (RFA) or Registered Entity (RE) (as these terms are defined in the Commodity Exchange Act, 7 U.S.C. 21 and 7 U.S.C. 1a(29)).

6. Exceptions: The following are exceptions to the FinCEN SAR reporting requirements:

- A bank, casino, broker or dealer in securities (BD), futures commission merchant (FCM), or introducing broker in commodities (IB-C) is not required to file a FinCEN SAR for a robbery or burglary committed or attempted against the financial institution when the robbery or burglary is reported to appropriate law enforcement authorities.
- A FinCEN SAR is not required to be filed for lost, missing, counterfeit, or stolen securities that are reported pursuant to the requirements of 17 CFR § 240.17f-1.
- A BD is not required to file a FinCEN SAR on violations of any of the Federal securities laws or the rules of a SRO by the BD or any of its officers, directors, employees or other registered representatives, other than a violation of 17 CFR § 240.17a-8 or 17 CFR § 405.4, so long as such violation is appropriately reported to the SEC or an SRO.
- An FCM or an IB-C, or any of its officers, directors, employees or associated persons, is not required to file a FinCEN SAR for a violation of the Commodity Exchange Act (7 U.S.C. 1 *et seq.*), the regulations of the CFTC (17 CFR Chapter 1), or the rules of any RFA or RE (as those terms are defined in the Commodity Exchange Act, 7 U.S.C. 21 and 7 U.S.C. 1a(29)), as long as such violation is appropriately reported to the CFTC, an RFA, or RE. This exception does not apply to violations of 17 CFR § 42.2.

- An insurance company is not required to report the submission to it of false or fraudulent information to obtain a policy or make a claim, unless the company has reason to believe that that the false or fraudulent submission relates to money laundering or terrorist financing.
- An issuer of money orders or traveler's checks is not required to report a transaction or pattern of transactions when the transactions were identified through a review of clearance records or other similar records and the transaction amount or aggregated transaction amount involves funds or other assets of less than \$5,000.

7. Additional Reporting: The Bank Secrecy Act requires financial institutions to file a Currency Transaction Report (CTR) in accordance with the Department of the Treasury's implementing regulations (31 CFR § 1010.310) whenever a currency transaction exceeds \$10,000. If a currency transaction exceeds \$10,000 and is otherwise reportable as suspicious activity, the institution must file both a CTR (reporting the currency transaction) and a FinCEN SAR (reporting the suspicious activity). If a currency transaction is \$10,000 or less and is otherwise reportable as a suspicious activity, the institution should only file a FinCEN SAR. Appropriate records must be maintained in each case. Residential Mortgage Lenders and Originators are required to file Form 8300, Report of Cash Payments Over \$10,000 Received in a Trade or Business, instead of a CTR.

9.6. FinCEN SAR Electronic Filing Instructions

9.6.1. General Instructions:

1. **Filing Reports:** This report must be E-filed through the Financial Crime Enforcement Network (FinCEN) BSA E-Filing System. Go to <http://bsaefiling.fincen.treas.gov> to register if not already registered. Financial institutions that file reports individually will use FinCEN's discrete FinCEN SAR to file their reports. Financial institutions that use batch filing or system-to-system filing to transmit multiple reports must transmit files that conform to the requirements of FinCEN's "General Specifications for Electronic Filing in XML format of Bank Secrecy Act (BSA) Reports" (General Specifications) and "FinCEN Suspicious Activity Report (FinCEN SAR) XML Filing Requirements."
2. **Recording Information:** Complete each FinCEN SAR by providing as much information as possible. Although all items should be completed fully and accurately, items marked with an asterisk (*) must be completed even when the required data are unknown. Filers must follow the electronic filing instructions for these items by providing the required data or, if instructions permit, by checking the box "Unknown" to indicate that the required data was unknown. Items that do not begin with an asterisk must be completed if the data are known and will be left blank if the data are unknown. If an item's instructions differ from the General Instructions the item's instructions must be followed. These instructions supersede all prior FinCEN SAR instructions and FinCEN guidance on use of special responses in FinCEN SAR items when the data are unknown or not available in an electronic filing. Therefore, the use of special responses such as "UNKNOWN," "NONE," "NOT APPLICABLE," or "XX" and their variants is prohibited in the FinCEN SAR.

NOTE: Throughout these instructions the phrases "check box" and "select option" or similar wording is used to denote checking an appropriate box or selecting a drop-down list option in certain data items on the discrete FinCEN SAR. These are deemed equivalent to instructions in the XML Filing Requirements to enter appropriate codes or responses in the same data items in XML-format transmission files. For example, the requirement to check box 1 "Initial report" in the discrete FinCEN SAR is the equivalent of entering "Y" in XML element <InitialReportIndicator>.

NOTE: Throughout these instructions there are requirements to complete items multiple times in a discrete FinCEN SAR if the filer has multiple entries for that item. This is deemed equivalent to completing multiple XML elements for that item in the XML Filing Requirements. For example, these instructions direct filers to complete multiple Item 6 "Alternate name" fields if the filer has knowledge of multiple alternate names for a subject. This is equivalent to a batch filer recording multiple XML <PartyName> elements and appropriate sub-elements for the same subject.

3. **Corrected/Amended Reports:** A corrected report on a previously-filed FinCEN SAR or prior FinCEN SAR version must be filed whenever errors are discovered in the data reported in that FinCEN SAR. An amended report must be filed on a previously-filed FinCEN SAR or prior FinCEN SAR versions whenever new data about a reported suspicious activity is discovered and circumstances will not justify filing a continuing report (see General Instruction 4). Both corrected and amended reports must be completed in their entirety, with the necessary corrections or amendments made to the data. In both cases box 1b “Correct/Amend prior report” must be checked. If known, the prior report’s BSA Identifier (BSA ID) must be entered in field 1e. If the prior report’s BSA ID is unknown, field 1e should be zero-filled. All corrections or amendments must be described completely at the beginning of the Part V Suspicious Activity Information – Narrative section. If a FinCEN SAR is filed to correct or amend a prior FinCEN SAR version, the FinCEN SAR must be completed in its entirety. This includes FinCEN SAR items that apply to the suspicious activity but were not present on the prior FinCEN SAR version. FinCEN SAR items not on the prior FinCEN SAR version need not be described in the narrative. BSA IDs are provided in acknowledgement records sent to member financial institutions by the BSA E-Filing System.
4. **Continuing Reports:** A continuing report may be filed on suspicious activity that continues after an initial FinCEN SAR is filed. Continuing reports should be filed on successive 90-day review periods until the suspicious activity ceases, but may be filed more frequently if circumstances warrant that. Filers have up to 30 days following the end of a review period to file the continuing report for a total of 120 days of review and filing deadline. Continuing reports must be completed in their entirety, including the information about all subjects involved in the suspicious activity and all financial institutions where the activity occurred. The continuing report Part V narrative should include all details of the suspicious activity for the 90-day period encompassed by the report, and only such data from prior reports as is necessary to understand the activity. Do not reproduce the narratives from prior reports in the continuing report. Provide both the dollar amount involved in the suspicious activity for the 90-day period in Item 29 and the cumulative dollar amount for the current and prior related reports in Item 31. If continuing losses are involved for a financial institution recorded in Part III, record the 90-day loss in Item 67 and the cumulative loss in Part V.
5. **Joint Report:** A FinCEN SAR may be jointly filed when two or more distinct financial institutions recorded in Part III “Information about Financial Institution Where Activity Occurred” collaborate in filing a single FinCEN SAR on suspicious activity involving all of the collaborating financial institutions. Financial institutions are “distinct” for this purpose when they are different legal entities; a financial institution is not distinct from its own branches. Joint filing of a single FinCEN SAR is prohibited when any of the Part I “Subject Information” subjects of the would-be jointly filed FinCEN SAR have a box in Item 24 checked that identifies the subject as a director, employee, officer, or owner/controlling shareholder of the filing institution or a would-be joint filer. In that case separate FinCEN SARs must be filed by each institution. To be a jointly-filed FinCEN SAR, box 1d “Joint report” must be checked. In addition, the filing institution listed in Part IV “Filing Institution Contact Information” must identify in Part V “Suspicious Activity Information – Narrative” which Part III “Information about Financial Institution Where Activity Occurred” institutions are joint filers. The filing institution must include joint filer contact information in Part V, along with a description of the information provided by each joint filer. Record joint filer information in Part III Items 51 through 65 and joint filer branch information in Part III Items 68 through 74. Filing a joint FinCEN SAR does not relieve joint filers of the responsibility to report information about the suspicious activity that was not included in the joint filing. A filing institution cannot designate another institution as a joint filer unless the designated joint filer is aware of and approves the FinCEN SAR filing in its entirety. A filer that designates another institution as a joint filer without gaining that institution’s agreement to the joint filing and approval of the contents of the joint filing may have committed a willful violation of the Bank Secrecy Act, if the improper designation leads to the disclosure of the FinCEN SAR filing to a person not entitled to information about the filing. Both filers and joint filers are required to keep copies of the FinCEN SAR and their own supporting documentation for five (5) years after the date of filing.
6. **Supporting Documentation:** Filers can include a single Microsoft Excel compatible comma separated values (CSV) file with no more than one megabyte of data as an attachment to the FinCEN SAR. The contents of this file must be described in Part V. This file would be most suitable for documenting transaction records that are too numerous to record in Part V. Do not include any other supporting documentation with the FinCEN SAR. Instead, describe in Part V other supporting documentation not included in the file. Filers must retain all supporting documentation or a business record equivalent for five (5) years from the date of the

report (31 CFR § 1010.430). All supporting documentation (such as copies of instruments; receipts; sale, transaction or clearing records; photographs; and surveillance audio or video recordings) must be made available to appropriate authorities upon request. See Attachment D for information on attaching comma separated (.CSV) files to a FinCEN SAR filing.

7. **Addresses:** For addresses in the U.S., Canada, or Mexico enter the permanent street address, city, two or three letter state/territory/province code, ZIP Code or foreign postal code, and two-letter country code or U.S. Territory code for the individual or entity recorded in Part I, Part III, or Part IV. Provide the apartment number or suite number, if known, following the street address. A non-location address such as a post office box or rural route number should be used only if no other street address information is available. ZIP Codes must be five or nine digits. ZIP Codes and foreign postal codes must be entered without formatting or special characters such as spaces or hyphens. For example, the ZIP Code 12345-6120 would be entered as 123456120. The foreign postal code HKW 702 would be entered HKW702. When an address is in a U.S. Territory the territory code must be entered in the state and country fields. For other foreign addresses enter the street address, city, postal code, and two letter country code or address equivalents. Leave the state item blank, including the "Unknown box" when provided. If a foreign address contains address information that does not conform to the FinCEN SAR address format, record equivalent address information in the FinCEN SAR address items (except state) and ignore non-conforming data. The complete foreign address should be recorded in the FinCEN SAR's Part V narrative section. Complete any address item that is known, even if the entire address is not known. No abbreviations are permitted in city names, which must be completely spelled out. A U.S. city name must match the city name used by the U.S. Postal Service for the associated state and ZIP Code. U.S. State codes must conform to the codes used by the United States Postal Service as documented in ISO 3166-2:US. Canadian province and territory codes must conform to the codes used by the Canadian Post Corporation as documented in ISO 3166-2:CA. Mexican state and federal district codes must conform to ISO 3166-2:MX. Country codes and U.S. Territory Codes must conform to the codes documented in ISO 3166-2. The ISO lists are available through the International Standards Organization.
8. **Telephone Numbers:** Record all telephone numbers, both foreign and domestic, as a single number string without formatting or special characters such as parentheses or hyphens. For example, a number in the format (NNN) NNN-NNNN would be recorded as NNNNNNNNNN. Indicate the type of telephone number provided (home, work, mobile, or fax) by checking the appropriate box. Provide the telephone extension number if known. Telephone numbers that are part of the North American Numbering Plan used by the U.S., Canada, many Caribbean countries, and current/former U.S. Pacific island protectorates must consist of an area code and seven-digit telephone number. Other foreign telephone numbers should include the country number code. If only a partial telephone number is known record that number in the phone number item and explain in Part V that the entry is a partial number.
9. **Identifying Numbers:** Enter all identifying numbers as a single text string without formatting or special characters such as hyphens or periods. An identifying number in the format NNN-NN-NNNN would be entered as NNNNNNNNNN. Such numbers include account numbers, alien registration numbers, CRD, CUSIP®, driver's license numbers, state identifications, EINs, IARDs ITINs, passport numbers, RSSDs, SEC IDs, and SSNs.
10. **Monetary Amounts:** Record all monetary amounts in U.S. Dollars rounded up to the next whole dollar. The amount \$5,265.25 would be rounded up to \$5,266. If the amount involves a foreign currency, record the currency name, amount, and country of origin in Part V. When converting a foreign currency to U.S. Dollars use an exchange rate for the date or dates the foreign currency was involved in the suspicious activity.
11. **Prohibited Words and Phrases:** Do not use the following words or variations of these words in text fields, other than in Part V:
 - a. AKA
 - b. COMPUTER GENERATED
 - c. CUSTOMER
 - d. DBA
 - e. NON CUSTOMER
 - f. NONE
 - g. NOT APPLICABLE
 - h. OTHER
 - i. SAME

- j. SAME AS ABOVE
 - k. SEE ABOVE
 - l. SEE NARRATIVE
 - m. SIGNATURE CARD
 - n. T/A
 - o. UNKNOWN
 - p. VARIOUS
 - q. XX
12. **Name Editing Instructions:** Because many names do not consist of a single first name, middle name, and last name, care must be taken to ensure these names are entered properly in the BSA FinCEN SAR. This is especially important when there are separate fields for the last name, first name, and middle name. Some names have multiple surnames (family names) or multiple given names that do not include a middle name. Others may not be written in [first name] [middle name] [last name] order. Multiple surnames must be entered in the last name field. For example, Hispanic names may be written in the order of given name, father's last name, and mother's last name, e.g., "Juan Vega Santiago." Thus the surname "VEGA SANTIAGO" would be entered in the last name field with "JUAN" entered in the first name field. Some Hispanic surnames consist of three names (e.g., father's last name, mother's last name, and husband's father's last name in the case of a married woman). In that case all three would be entered in a last name field. Hispanic names do not have middle names, so a multiple Hispanic given name such as "Rosa Maria" would be recorded in the first name field. In some cultures names consist of multiple first names and a single family name, not necessarily in (first name) (last name) order. For example, the Korean name "Kim, Chun Nam" consists of the family name "Kim" and the first name "Chun Nam" separated by a comma and space. There is no middle name. In this case "KIM" would be entered in the last name field and "CHUN NAM" would be entered in the first name field. Nothing is entered in the middle name field. When an individual name is entered in a single name field it should be entered in [first name] [middle name] [last name] order regardless of any foreign naming conventions. Thus, "Kim, Chun Nam" would be entered as "CHUN NAM KIM" in a single name field. Punctuation and special characters should be used in names only when they are part of the name. For example, the period in "Expedia.Com" should be included because it is part of the name. Entry of middle initials is permitted when a middle name is unknown. Do not include a period after a middle initial when the initial represents a name abbreviation. Abbreviations in names are prohibited unless an abbreviation is part of a legal name or the name is unknown. A name suffix may be abbreviated, i.e. Junior can be JR, Senior can be SR, the Third can be III, etc.
13. **Reporting Cyber Events:** Cyber events directly affecting the financial institution or the financial institution's customer are occurring on an ever-increasing basis. Since the implementation of the new FinCEN SAR in 2011, a significant number of FinCEN SARs have been filed to record the events with the data being recorded in Part V, the FinCEN SAR Narrative. The data collected and submitted has provided law enforcement with valuable leads and insight into this emerging field. A review of the data reported indicates that prompt retrieval of cyber event information is a critical step in combating malicious cyber activity. To facilitate and support prompt identification and retrieval of malicious cyber event information, specific cyber fields (42, 43, and 44) have been added to Part II, the Suspicious Activity Information section of the FinCEN SAR. These fields are not meant to be exhaustive or to replace attachments. Use of these fields to highlight selected information (that may also be in attachments) can assist law enforcement in identifying key indicators. Due to the growing prevalence and technological sophistication of cyber-enabled financial crime, FinCEN encourages financial institutions to develop a basic understanding of what comprises a cyber event. Being familiar with selected key vocabulary is essential in describing these cyber events to law enforcement. Completion of cyber event fields 42 to 44 is not mandatory, but is encouraged where financial institutions have sufficient capacity to do so. While use of the fields may not be mandatory, filing on certain cyber events and cyber-enabled financial crime may be mandatory under existing filing requirements—see FinCEN Advisory FIN-2016-A005 for more information.
- A principal source of cyber related information will be the financial institutions' internal technology department or external technology contractor. FinCEN recognizes that institutions have varying familiarity with and access to cyber-related information in their compliance departments and therefore encourages the involvement of available IT resources on an ongoing basis. Financial institutions should review established internal departmental protocols to ensure prompt review and reporting of cyber event information.

Reporting cyber event information is not a new requirement and financial institutions are expected to report this information when available. To assist institutions in identifying when to use the new cyber fields, FinCEN is providing the examples below. Please note that these examples highlight instances where an institution may be limited in its ability to identify cyber-related information due to limits in cyber expertise or resource availability. Each example is an acceptable and appropriate use of these fields.

Example 1.

Bank A is told by its customer, ABC Corp, that a recent wire payment issued from its account was fraudulent. Bank A is told that fraudsters imitated the CEO of ABC Corp.'s e-mail to instruct ABC employees to wire funds from ABC's accounts at Bank A to an account at Bank B. ABC Corp tells Bank A that these fraudulent e-mails were made to look like the CEO used the e-mail address CEO@ABCcorp.co instead of the legitimate CEO@ABCcorp.com. These fraudulent e-mails appeared to be instructing employees to issue urgent payments to one of ABC's suppliers for \$300,000. Bank A recognizes this as a Business E-mail Compromise (BEC) scheme. In the FinCEN SAR narrative, Bank A describes the incident and mentions the term "BEC Fraud" and FinCEN advisory FIN-2016-A003.

Bank A places the following information in the new fixed fields on the FinCEN SAR form:

Item 42: Cyber Event

b. Against Financial Institution Customer(s) [check box]

Field 44f. Suspicious e-mail address

44f1. Event value: CEO@ABCcorp.com

Example 2.

Bank A is told by its customer, ABC Corp, that a recent wire payment issued from its account was fraudulent. Bank A is told by its customer that the CEO of ABC Corp.'s e-mail was hacked and used to instruct ABC employees to wire funds from ABC's accounts at Bank A to an account at Bank B. ABC Corp tells Bank A that these e-mails were made to look like the CEO was instructing employees to issue payments to ABC's suppliers for \$300,000. No additional technical information was provided to Bank A. Bank A recognizes this as a Business E-mail Compromise (BEC) scheme. In the FinCEN SAR narrative, Bank A describes the incident and mentions the term "BEC Fraud" and FinCEN advisory FIN-2016-A003.

Bank A places the following information in the new fixed fields on the FinCEN SAR form:

Item 42: Cyber Event

b. Against Financial Institution Customer(s) [check box]

Item 44: BLANK

Example 3.

Bank C identifies a cyber incident that targeted Bank C's own systems, resulting in access to Bank C's payment systems and an attempted transfer of \$1 million through Bank C's 123-wire system. Bank C's compliance team asks its IT department for additional technical information related to this incident, and whether there were any key indicators associated with the event. The IT department is still gathering information, but has identified one piece of relevant malware and the IP address that relayed instructions to attempt the \$1 million funds transfer. They also have a .csv file containing possibly related technical information that Bank C decides to include as an attachment.

Bank C files a FinCEN SAR with the following information in the new fixed fields:

Item 42: Cyber Event

a. Against Financial Institution [check box]

Field 44a. Command & Control IP Address

44a1. Event value: 127.0.0.1
 44a2. Date (2017/01/01)
 44a3. UTC Time (00:00:01)
 Field 44c. Malware MD5, Malware SHA-1, Malware SHA-256:
 44c1Event value: 9e107d9d372bb6826bd81d3542a419d6
 Field 44j. Targeted System:
 44j1. Event value: 123-wire

Example 4.

Bank D identifies an incident that targeted Bank D's own systems, resulting in access to Bank D's payment systems and an attempted transfer of \$50,000 through Bank D's 123-wire system. Bank D's compliance team asks its IT department for additional technical information related to this incident, and whether there were any key indicators associated with the event. Bank D's IT department confirms that the incident was a cyber event against Bank D, but is unable to spend resources locating additional information due to their necessary focus on continuity of business operations. Bank D files a FinCEN SAR based on the available information.

Bank D files a FinCEN SAR with the following information in the fixed fields:

Item 42: Cyber Event
 a. Against Financial Institution [check box]
 Field 44j. Targeted System:
 44j1. Event Indicator value: 123-wire

Example 5.

Bank E is told by its customer that a fraudulent wire was sent from their online banking account. The customer does not know how fraudsters gained access to their account. Bank D is able to identify the record of the fraudulent wire and when it occurred. Bank D's compliance department asks its IT department for IP log information associated with the targeted customer's account at the time of the fraudulent wire transfer. The IT department is able to provide the information from their logs.

Bank E files a FinCEN SAR with the following information in the new fixed fields:

Item 43:
 a. IP address: 127.0.0.1
 b. Date: 2017-01-30
 c. UTC Time: 00:00:01

9.6.2. Item Instructions:

NOTE: Critical fields are identified with the * symbol in front of the data element number.

----- Type of Filing -----

*1. Type of filing (*check all that apply*)

- a. Initial report
- b. Correct/Amend prior report
- c. Continuing activity report
- d. Joint report
- e. Prior report BSA Identification Number if items 1b or 1c are checked

Item *1 Type of filing: Check box 1a "Initial report" if this is the first report filed on the suspicious activity. Check box 1b "Correct/Amend prior report" if the report corrects or amends a previously-filed FinCEN SAR. See General Instruction 3 for additional instructions on filing corrected or amended SARs. Check box 1c "Continuing activity report" if the FinCEN SAR continues reporting on previously-reported suspicious activity. If the FinCEN SAR corrects a

previously-filed continuing activity report, both 1b and 1c must be checked. See General Instruction 4 for additional instructions on filing continuing activity reports. Check box 1d "Joint report" if a FinCEN SAR of any filing type is filed jointly by two or more financial institutions. See General Instruction 5 for additional instructions on filing joint reports. If box 1b or 1c is checked, the prior report's BSA Identifier (BSA ID) must be recorded in field 1e. Enter 14 zeros if the prior report BSA ID is unknown.

2. Filing Institution Note to FinCEN

Item 2, Filing Institution Note to FinCEN: This 50 character field is provided for the filer to alert FinCEN that this FinCEN SAR is being filed in response to a current specific geographic targeting order (GTO) or advisory or other activity. If completing for a GTO or advisory enter the GTO or advisory title/reference. Provide a brief description of the other activity. Leave Item 2 blank if the FinCEN SAR does not relate to a GTO, advisory, or other targeted activity.

----- Part I Subject Information -----

Part I Subject Information: Complete a Part I section on each known subject involved in the suspicious activity. Persons who are victims of the suspicious activity are not subjects and should not be recorded in a Part I section. Victim information, if necessary for a complete description of the suspicious activity, should be recorded in Part V. If the subject is or all subjects are unknown, complete a single Part I record with box 2b checked to show that all subject information was unavailable for critical Items 4, 5, 11, 12, 13, 14, 15, 17, and 18. These critical items (denoted with an asterisk "**") except Item 24 must be blank. Record the nature of the unknown subject(s) in Part V. If the suspicious activity involves known and unknown subjects, complete a Part I section on each known subject and record the nature of the unknown subject(s) in Part V. Do not complete Part I records on the unknown subjects when there are known subjects.

3. Check:

- a. If entity
- b. If all critical* subject information is unavailable (does not include item *25)

Item 3a Check if entity: Check box 3a if the person described in Part I is an entity and not an individual. Item 3b Check if all critical subject information is unavailable: Check box 3b if the information in Part I is unavailable for all critical subject items except Item 25. These critical items (4, 5, 11, 12, 13, 14, 15, 17, and 18) and their associated "Unknown" fields must be left blank.

* 4. Individual's last name or entity's legal name

- a. (check if) unknown

Item *4 Individual's last name or entity's legal name: Enter the individual's last name or the entity's legal name. The legal name is the name on the articles of incorporation or other document that established the entity. Do not abbreviate names unless an abbreviation is part of the legal name. Item 4 and box 4a "Unknown" must be blank if box 3b is checked. Leave item 4 blank and check box 4a "Unknown" if the individual's last name or the entity's legal name is unknown and box 3b is not checked.

* 5. First name

- a. (check if) unknown

Item *5 First name: Enter the individual's first name. If the first name is unknown leave item 5 blank and check box 5a "Unknown." Leave Item 5 and box 5a "Unknown" blank if box 3a or 3b is checked.

6. Middle name

Item 6 Middle name/initial: Enter the individual's middle name or initial. Leave this item blank if the middle name or initial is unknown or box 3a is checked.

7. Suffix

Item 7 Suffix name: Enter the individual's suffix such as JR, SR, III, etc. Leave this item blank if the suffix is unknown or the individual's legal name does not include a suffix.

8. Gender

- a. Male
- b. Female
- c. Unknown

Item 8 Gender: Select options 8a Male or 8b Female if individual's gender is known. Select option 8c "Unknown" if the individual's gender is unknown. Leave Item 8 blank if the subject is an entity. Item 8 (Gender) does not create an obligation for a financial institution to collect this data when such collection would be in conflict with the financial institution's obligations under any other federal law.

9. Alternate name, e.g., AKA if individual; DBA/ trade name if entity.

Item 9 Alternate name: Enter the individual's also known as (AKA) name or the entity's doing business as (DBA) name if different from the name entered in Items 4-6. Do not include the acronyms AKA or DBA with the name. Multiple Item 9 fields may be completed if multiple subject alternate names are known.

10. Occupation or type of business

- a. NAICS Code

Item 10 Occupation or type of business: Record the occupation, profession, or type of business of the individual or entity recorded in Part I. Use specific descriptions such as doctor, carpenter, attorney, used car dealership, plumber, truck driver, hardware store, etc. Do not use non-descriptive items such as businessman, merchant, retailer, retired, or self-employed. If words like self-employed, unemployed, or retired are used, add the current or former profession if known (e.g. self-employed building contractor, retired teacher, or unemployed carpenter). If the occupation or business activity can be described in more detail, include the additional information in Part V.

Item 10a NAICS Code: select the North American Industry Classification System (NAICS) code for the occupation or type of business entered in Item 10. Batch filers should only enter codes from the list of NAICS Codes authorized for use in the FinCEN SAR and located on the BSA E- Filing Web Site (<http://bsaeifiling.fincen.treas.gov/main.html>) or from the U.S. Census Bureau NAICS list at <https://www.census.gov/cgi-bin/sssd/naics/naicsrch?chart=2017>. If the Census Bureau list is used filers cannot substitute a sector code (such as 11 Agriculture, Forestry, Fishing and Hunting) for an actual three to six number NAICS Code (such as 11114 Wheat Farming).

Items *11 - *14 Subject address items: Enter the subject's permanent street address, city, two or three letter state/territory/province code (U.S./Canada/Mexico only), ZIP Code or foreign postal code, and two letter country or U.S. Territory code. Complete any address item that is known, even if the complete address is unknown. If an address item is unknown, leave that item blank and check box 11a "Unknown." If box 3b is checked all address items and check boxes must be blank. See General Instruction 7 for additional information on entering addresses. Multiple sets of address fields may be completed if multiple present and past subject addresses are known.

*11. Address

- a. (check if) unknown

*12. City

- a. (check if) unknown

13. State

- a. (check if) unknown

*14. ZIP/Postal Code

- a. (check if) unknown

*15. Country Code

- a. (check if) unknown

*16. TIN (enter number in space provided and check appropriate type below)

- b. (check if) unknown

Item *16 TIN: Enter the subject's U.S. taxpayer identification number (TIN) or foreign equivalent without formatting or punctuation. If the number is unknown, check box 16a "Unknown" and leave Item 16 blank. Leave item 16 and box 16a "Unknown" blank if box 3b is checked. See General Instruction 9 for information on entering identifying numbers.

17. TIN type

- a. EIN
- b. SSN-ITIN
- c. Foreign

Item 17 TIN type: Identify the type of TIN recorded in Item 16. Select option 17a "EIN" if the subject has a U.S. Employer Identification Number (EIN). Box 3a "If entity" must be checked because an EIN is assigned only to an entity. Select option 17b "SSN-ITIN" if the subject has a U.S. Social Security Number (SSN) or Individual Taxpayer Identification Number (ITIN). Select option 17c "Foreign" if the subject has a foreign TIN of any type. Box 3a must be checked if the foreign subject is an entity. If 17c is checked, record in Part V the name of the country that issued the foreign TIN. Enter the subject's TIN type if known even if the actual TIN is unknown and Item 16a "Unknown" is checked. If a 9-digit TIN is entered in Item 17 but the TIN type is unknown, select option 17a "EIN" if the subject is an entity and option 17b "SSN-ITIN" if the subject is an individual. TINs that are not 9 digits are presumed to be foreign, so option 17c "Foreign" would be selected.

* 18. Form of identification for subject:

- a. (check if) unknown
- b. Driver's license/state ID
- c. Passport
- d. Alien registration
- e. Number
- f. Issuing State
- g. Country
- z. Other (and specify type in space provided)

Item *18 Form of identification: Enter in Item 18 the information used to identify the individual or entity. Select option 18b if the identification was a driver's license or state ID, 18c if the identification was a passport or 18d if the identification was an alien registration. Select option 18z if a different identification was provided and describe that identification in the "Other" text field. "Other" identification could include such things as an entity's business license or incorporation documents, corporate ID cards, local government ID cards, etc. Enter the identification number in field 18e "Number." Do not include formatting such as hyphens or periods. Select the appropriate state option in field 18f "Issuing state" if the identification issuer was a U.S., Canadian, or Mexican state, territory, or province. Select the appropriate country option in field 18f "Country" if the issuer was a country. If field 18f "Issuing state" contains an entry, then 18g "Country" must contain "US," "CA," or "MX" as appropriate. Enter the data on the country that issued the ID or where the ID was issued. See General Instruction 7 for information about the codes to enter in state and country items. If the identification issuer does not have a code, select the option for the issuer's country in field 18g. For example, if the issuer was the London Police Department United Kingdom would be selected in 18g. Record the name and nature of the issuer in Part V. Enter all identification data that is available. Check box 18a "Unknown" only if all identification information is unknown but the subject is known. Leave all fields in Item 18 blank if box 3b has been checked. Multiple sets of Item 18 fields may be completed if multiple types of identification for a subject are known. See General Instruction 9 for information on entering identifying numbers.

* 19. Date of birth MM/DD/YYYY

- a. (check if) unknown

Item *19 Date of birth: If the subject is an individual enter the subject's data of birth in Item 19. Filers of FinCEN's discrete FinCEN SAR must use the format MM/DD/YYYY where MM = month, DD = day, and YYYY = year. Batch filers must use the format YYYYMMDD. If the birth day and or month is unknown, enter "00" for the unknown day

or month. For example, a date of birth with an unknown day in February 1978 would be entered as 02/00/1978 in a discrete FinCEN SAR and 19780200 in a batch filed FinCEN SAR. Do not enter zeros for the year if the year is unknown. If the year of birth or the complete date of birth is unknown, check box 19a "Unknown" and leave Item 19 blank. If box 3a or b is checked, Item 19 and box 19a "Unknown" must be blank.

20. Phone number – type

- a. Home
- b. Work
- c. Mobile
- d. Fax

Item 20 Phone number – type: selected the telephone number type that applies to the telephone number recorded in Item "21. Phone Number." If a number is known but the type is unknown leave Item 20 blank. If a number is known but the type is unknown, select option "a. Home" if the subject is an individual and "b. Work" if the subject is an entity. Multiple sets of Item 20, Item 21, and Item 21a fields may be completed if multiple telephone numbers for the subject are known

21. Phone number

- a. Extension (*if any*)

Item 21 Phone number: Enter the subject's U.S. or foreign telephone number with no formatting such as parentheses, spaces, or hyphens. If the telephone number is unknown, leave item 21 blank. See General Instruction 8 for information on entering telephone numbers. Multiple sets of Item 21 and Item 21a fields may be completed if multiple telephone numbers for the subject are known.

Item 21a Ext. (*if any*): Enter the telephone extension associated with the subject's telephone number. Leave Item 21a blank if there is no extension or the extension is unknown.

22. E-mail address (*if available*)

Item 22 E-mail address: Enter the subject's e-mail address if known. Include all formatting, punctuation, and special characters in the e-mail address. Leave Item 22 blank if the e-mail address is unknown. If additional e-mail addresses are known for a subject, complete additional Item 22 fields. An e-mail address must contain the "@" sign and a period in the text following the "@" sign. Examples: [johndoe@business.com](mailto: johndoe@business.com) or [richardroephd@college.edu](mailto: richardroephd@college.edu).

22a. Website (URL) address (*if available*)

Item 22a Website (URL) address: Enter the subject's website URL (Uniform Resource Locator) known. Include all punctuation and special characters present in the URL. If additional URLs are known for a subject, complete an additional Item 22a for each URL. Leave Item 22a blank if the URL is unknown.

23. Corroborative statement to filer?

- a. Yes
- b. No

Item 23 Corroborative statement: Select "Yes" if the subject individual has made a statement to the filer admitting to involvement in or otherwise substantiating the suspicious activity. Record in Part V the nature of the corroborative statement and how it was recorded, i.e. written confession, verbal statement, etc. Select "No" if no corroborative statement was made to the filer. Leave Item 23 blank if the subject is an entity

24. Relationship of the subject to an institution listed in Part III or IV (*check all that apply*)

- a. Institution TIN
- b. Accountant
- c. Agent
- d. Appraiser
- e. Attorney

- f. Borrower
- g. Customer
- h. Director
- i. Employee
- j. No relationship to institution
- k. Officer
- l. Owner or Controlling Shareholder
- z. Other (and specify type in space provided)

Item 24 Relationship of the subject to an institution: If the subject has a relationship with a financial institution or individual listed in Part III or Part IV, enter the financial institution's TIN from Items 55 or 81 in field 23a "Institution EIN." Select all options 24b through 24l (but not 24j no relationship) that describe the relationship. If the relationship is not covered by any of options 24b through 24l, select option 24z "Other" and enter a brief description of the relationship in the "Other" text field. Avoid descriptions that are too general. For example, the entry "broker" should be made more specific by indicating the relationship was "real estate broker," "securities broker," or "mortgage broker." If necessary, describe the relationship more fully in Part V. If the subject has no relationship with any of the financial institutions in Part III or Part IV, record box 24j "No relationship to institution" once for all institutions and enter the Part IV filing institution's EIN in the Item 24 "Institution TIN" field. Do not record box 24j for the subject if a relationship exists with any institution, even when there is no relationship with other institutions." The FinCEN SAR cannot be a joint FinCEN SAR if any of the options 24h "Director," 24i "Employee," 24k "Officer," or 24l "Owner or Controlling Shareholder" have been selected. If the subject had a relationship with a financial institution recorded in Part III but the financial institution's TIN was unknown, record the relationship but leave field 24a blank. If the subject has relationships with multiple Part III and Part IV financial institutions, complete a separate set of Item 24 fields for each financial institution. If more than one of 24h "Director," 24i "Employee," 24k "Officer," or 24l "Owner or Controlling Shareholder" is selected and/or the status or action date is different for each, an Item 24 for each must be completed.

25. If item 24h, i, k, or l is checked, indicate status of relationship

- a. Relationship continues
- b. Terminated
- c. Suspended/barred
- d. Resigned

Item 25. If item 24h, i, k, or l is selected: If any of boxes 24h, 24i, 24k, or 24l are selected, select the appropriate Item 25 option to indicate the status of the relationship. Select option 25a if the relationship continues. Select option 25b if the subject was terminated, 25c if the subject was suspended or barred, or 25d if the subject resigned. If multiple sets of Item 24 fields are completed on a subject, complete an Item 25 field for each set.

26. Action date MM/DD/YYYY if 25 b, c, or d is checked

Item 26 Action date: If any of boxes 25b through 25d have been checked, enter the date the action was taken. The date must be in MM/DD/YYYY format in a discrete FinCEN SAR and in YYYYMMDD format in a batch-filed FinCEN SAR. Leave Item 26 blank if no action was taken. If multiple Item 24 fields were created where box 25b, 25c, or 25d was checked, complete an Item 25 for each Item 24.

* 27. Financial Institution TIN and account number(s) affected that are related to subject, if any.

- a. *(check if)* No known account involved
- b. *(check if)* Non-U.S. financial institution
- c. TIN
- d. account number
- e. *(check if)* closed

Item 27 Financial institution TIN and acct. number(s) affected that are related to the subject, if any: Enter in Item 27 information about any accounts involved in the suspicious activity that are related to the subject recorded in Part I.

Enter account numbers without formatting or special characters such as spaces, hyphens, or periods. See General Instruction 9 for information about entering account numbers in fields. An account is related to a subject if the subject owns the account, has control over the account, or conducted activity in or through an account the subject does not own or control. Check box 27a "No known acct. involved" if no account related to the subject is involved in the suspicious activity. Check box 27b "Non-US Financial Institution" if the account is located at a foreign financial institution. Enter in field 27c the TIN, if known, of the financial institution where the account is held. If the TIN is unknown leave the TIN field blank. Enter the account number involved in field 27d. If the account is closed, check the "Yes" box. If multiple account numbers are involved in the suspicious activity, complete an additional set of account number fields for each account number. Record account numbers involved in the suspicious activity that are related to the subject even if the TIN or name of the financial institution is unknown. If the TIN of a financial institution associated with an account number entered in 27d is unknown, record the institution name and associated account number in Part V (example: "The account number 123654987 is held at First Federal Bank."). If the filer is aware that the subject has an account involved in the suspicious activity with a financial institution listed in Part III but the account number is unknown, record the financial institution TIN in Item 27a but leave the associated account number field blank. Explain the missing account number in Part V. The subject's relationship to any account recorded in Item 27 must be clearly defined in Part V unless the subject is the owner of the account (example: "The subject made unauthorized purchases using a stolen debit card for account 3456789 owned by his aunt.").

28. Subject's role in suspicious activity (*if applicable*)

- a. Purchaser/Sender
- b. Payee/Receiver
- c. Both a & b

Item 28 Subject's role: Record the subject's role in the suspicious activity by selecting the appropriate option. Select option 28a "Purchaser/Sender" if the subject purchased or sent the financial instrument(s) or product(s) involved in the suspicious activity. Select option 28b "Payee/Receiver" if the subject was the payee or receiver of the instrument(s) or product(s). Select option 28c "Both a & b" if the subject was both a purchaser/sender and payee/receiver. Instruments and products are not limited to the instruments and products listed in Items 45 and 46.

Note: Item 28 generally applies to institutions such as MSB's or depository institutions through which the subject conducted transactions involving wire transfers, traveler's checks, money orders, or like products/financial instruments

----- Part II Suspicious Activity Information -----

* 29. Amount involved in this report

- a. (*check if*) Amount unknown
- b. (*check if*) No amount involved

Item *29 Amount involved in this report: Enter the total amount involved in the suspicious activity for the time period of this report. Multiple amounts will be aggregated and the total recorded in Item 29. This requirement applies even when the amounts involve different transaction types, such as when some are deposits and some are withdrawals. All amounts are aggregated and recorded as the total amount. If some amounts are known and some are unknown, the known amounts are aggregated and the total is recorded in Item 29. Unknown amounts are explained in Part V. If the amount or all amounts involved in the suspicious activity are unknown, box 29a "Amount unknown" is checked and the Item 29 amount field will be blank. Explain in Part V why the amount or amounts are unknown. Check box 29b "No amount involved" and leave the amount field blank if the suspicious activity did not involve any monetary amounts. Never enter "0" in the Item 29 amount field under any circumstance. Never enter a small amount such as \$1 or \$5 to complete the amount field when that entry is not the actual amount involved. If the FinCEN SAR is a continuing report with box 1c "Continuing activity report" checked, enter only the total of amounts that are involved for the time period covered by this FinCEN SAR. Do not include amounts from prior FinCEN SARs in Item 29. Prior FinCEN SAR amounts and the current FinCEN SAR total amount are aggregated in Item 31 "Cumulative amount only if box 1c (continuing activity report) is checked." See General Instruction 9 for information on entering amounts.

*30. Date or date range of suspicious activity for this report

- a. From: MM/DD/YYYY
- b. To: MM/DD/YYYY

Item *30 Date or date range of suspicious activity for this report: Enter the suspicious activity date or date range for this report. If the suspicious activity occurred on a single day, enter that date in field 30a "From" and leave field 30b "To" blank. If the suspicious activity occurred on multiple days, enter the earliest date of suspicious activity in field 30a and the most-recent date of suspicious activity in field 30b. If the exact date(s) of the suspicious activity is (are) unknown, enter a date range that the filer believes will encompass the date(s) of the suspicious activity. Explain the nature of this date range in Part V. If the FinCEN SAR involves continuing activity with box 1c "Continuing activity report" checked, enter only the date range covered by this FinCEN SAR. Record in Part V the aggregated date range of all FinCEN SARs filed on the continuing suspicious activity. Use the format MM/DD/YYYY for dates in a discrete FinCEN SAR and the format YYYYMMDD for dates in a batch-filed FinCEN SAR.

31. Cumulative amount only if box 1c (continuing activity report) is checked

Item 31 Cumulative amount: Enter the cumulative amount involved in the suspicious activity in Item 31 if box 1c "Continuing activity report" is checked. The cumulative amount represents the total amount involved in all FinCEN SARs filed on the suspicious activity, including the current FinCEN SAR. If box 1c is checked and the cumulative dollar amount is unknown because all dollar amounts are unknown or no dollar amount is involved, enter zero (0) and explain the entry in Part V. If some dollar amounts are known while others are unknown, enter the total of all known amounts in Item 31 and explain the nature of the unknown amounts in Part V. See General Instruction 10 for information on entering amounts. Leave Item 31 blank if box 1c is not checked.

Items 32 - 41 Types of suspicious activity: Use the suspicious activity category Items 32 through 41 to record the type(s) of suspicious activity being reported. Check all boxes that apply to the suspicious activity. If a category applies but none of the options apply, check the category's box "z Other" and briefly describe the type of suspicious activity in the associated text field. If necessary, explain the type of suspicious activity in more detail in Part V.

Note: Items 32-41 are considered critical. At least one item in 32 to 41 must be checked.

32. Structuring

- a. Alters or cancels transaction to avoid BSA recordkeeping requirement
- b. Alters or cancels transaction to avoid CTR requirement
- c. Suspicious inquiry by customer regarding BSA reporting or recordkeeping requirements
- d. Transaction(s) below BSA recordkeeping threshold
- e. Transaction(s) below CTR threshold
- z. Other (specify type of suspicious activity in space provided)

33. Terrorist financing

- a. Known or suspected terrorist / terrorist organization
- z. Other (specify type of suspicious activity in space provided)

34. Fraud

- a. ACH
- b. Advance fee
- c. Business loan
- d. Check
- e. Consumer loan
- f. Credit/Debit card
- g. Healthcare/Public or private health insurance
- h. Mail
- i. Mass-marketing

- j. Ponzi scheme
- k. Pyramid scheme
- l. Securities fraud
- m. Wire
- z. Other (specify type of suspicious activity in space provided)

35. Gaming activities

- a. Chip walking
- b. Minimal gaming with large transactions
- c. Suspicious use of counter checks or markers
- d. Unknown source of chips
- z. Other (specify type of suspicious activity in space provided)

36. Money laundering

- a. Exchanges small bills for large bills or vice versa
- b. Funnel account
- c. Suspicion concerning the physical condition of funds
- d. Suspicion concerning the source of funds
- e. Suspicious designation of beneficiaries, assignees or joint owners
- f. Suspicious EFT/wire transfers
- g. Suspicious exchange of currencies
- h. Suspicious receipt of government payments/benefits
- i. Suspicious use of multiple accounts
- j. Suspicious use of noncash monetary instruments
- k. Suspicious use of third-party transactors (straw-man)
- l. Trade Based Money Laundering / Black Market Peso Exchange
- m. Transaction out of pattern for customer(s)
- z. Other (specify type of suspicious activity in space provided)

37. Identification / Documentation

- a. Changes spelling or arrangement of name
- b. Multiple individuals with same or similar identities
- c. Provided questionable or false documentation
- d. Provided questionable or false identification.
- e. Refused or avoided request for documentation
- f. Single individual with multiple identities
- z. Other (specify type of suspicious activity in space provided)

38. Other suspicious activities

- a. Account takeover
- b. Bribery or gratuity
- c. Counterfeit instruments
- d. Elder financial exploitation
- e. Embezzlement/theft/disappearance of funds
- f. Forgeries
- g. Human smuggling
- h. Human trafficking
- i. Identity theft

- j. Little or no concern for product performance penalties, fees, or tax consequences
- k. Misuse of position or self-dealing
- l. Suspected public/private corruption (domestic)
- m. Suspected public/private corruption (foreign)
- n. Suspicious use of informal value transfer system
- o. Suspicious use of multiple transaction locations
- p. Transaction with no apparent economic, business, or lawful purpose
- q. Transaction(s) involving foreign high risk jurisdiction
- r. Two or more individuals working together
- s. Unlicensed or unregistered MSB
- z. Other (specify type of suspicious activity in space provided)

39. Insurance

- a. Excessive insurance
- b. Excessive or unusual cash borrowing against policy/annuity
- c. Proceeds sent to or received from unrelated third party
- d. Suspicious life settlement sales insurance (e.g. STOLIs, Viaticals)
- e. Suspicious termination of policy or contract
- f. Unclear or no insurable interest
- z. Other (specify type of suspicious activity in space provided)

40. Securities / Futures / Options

- a. Insider trading
- b. Market manipulation
- c. Misappropriation
- d. Unauthorized pooling
- e. Wash Trading
- z. Other (specify type of suspicious activity in space provided)

41. Mortgage fraud

- a. Application fraud
- b. Appraisal fraud
- c. Foreclosure/Short sale fraud
- d. Loan modification fraud
- e. Origination fraud
- z. Other (specify type of suspicious activity in space provided)

42. Cyber event (If reporting)

- a. Against Financial Institution(s)
- b. Against Financial Institution Customer(s)
- z. Other (specify type of suspicious activity in space provided)

Item 42, Cyber event: Complete item 42 to indicate if the cyber event was directed against the financial institution or its customer/account holder. Events against the institution may include, but not limited to, a digital denial of service (DDoS), an attempt to break (hack) into the financial institutions computer system or an attempt to take over the financial institutions "wire transfer system," the financial institutions website, a Business E-Mail Attack (BEA), etc. Examples of cyber events against the financial institutions customer may include the takeover (or attempted takeover)

of the customer's account, the sending of bogus e-mails that appear to come from the customer directing various financial transactions that do not follow the customers normal account activity, etc.

43. IP Address(es) *(if available, multiples up to 99)*

- a. Date (MM/DD/YYYY)
- b. Time Stamp (UTC) HH:MM:SS

Item 43 IP address: If known, enter the IP address of the subject's electronic internet based contact with the financial institution. For example, this may be the IP address used to log into the institution's online banking page or the IP address used to access an institution's mobile application. In item 43a enter the date (MM/DD/YYYY format) of the activity. In 43b enter the UTC time in (HH:MM:SS format) of the first instance of the reported IP address. Select the (+) sign to report multiple IP address, date and time information. IP address information must be explained in the FinCEN SAR Part V narrative. Batch filers will use the date format YYYYMMDD.

NOTE: If reporting an IP address in connection with a cyber-event, complete item 44.

Item 44. Cyber-event indicator *(multiple entries up to 99)*

Item 44 Cyber-event indicator: Enter the cyber-event indicator by selecting the appropriate indicator from the dropdown list provided and enter the supporting information in the associated text field (an indicator not listed may be entered in the "z" Other text fields. Select the (+) sign to report multiple event indicators. Each cyber-event indicator and its associated text field is limited to 99 entries. Cyber-event indicator information must be explained in the BFinCEN SAR Part V narrative. See General Instruction 13 for additional information on reporting cyber-related events.

44a. Command and Control IP address

44a1 Event value text field (each entry of 44a must have a corresponding event value text field).

44a2 Event value text field (Date associated with the value in 44a1).

44a3 Event value text field (Timestamp associated with the value in 44a1).

44b. Command & Control URL/Domain

44b1 Event value text field. (each entry of 44b must have a corresponding event value text field)

44c. Malware MD5, Malware SHA-1, or Malware SHA-256.

44c1 Event value text field. (each entry of 44c must have a corresponding event value text field)

44d. Media Access Control (MAC) Address

44d1 Event value text field (each entry of 44d must have a corresponding event value text field).

44e. Port

44e1 Event value text field. (each entry of 44e must have a corresponding event value text field)

44f. Suspicious e-mail address

44f1 Event value text field. (each entry of 44f must have a corresponding event value text field)

44g. Suspicious filename

44g1 Event value text field. (each entry of 44g must have a corresponding event value text field)

44h. Suspicious IP Address

44h1 Event value text field. (each entry of 44h must have a corresponding event value text field)

44h2 Event value Date associated with the value in 44h1 (discrete format MM/DD/YYYY and batch format YYYYMMDD).

44h3 Event value Timestamp associated with the value in 44h1.

44i. Suspicious URL/Domain

44i1 Event value text field. (each entry of 44i must have a corresponding event value text field)

44j. Targeted system

44j1 Event value text field. (each entry of 44j must have a corresponding event value text field)

44z. Other

44z Text description of Other value

44z1 Event value text field. (each entry of 44z must have a corresponding event value text field)

45. Were any of the following product type(s) involved in the suspicious activity? Check all that apply:

- a. Bonds/Notes
- b. Commercial mortgage
- c. Commercial paper
- d. Credit card
- e. Debit card
- f. Deposit account
- g. Forex transactions
- h. Futures/Options on futures
- i. Hedge fund
- j. Home equity line of credit
- k. Home equity loan
- l. Insurance/Annuity products
- m. Microcap securities
- n. Mutual fund
- o. Options on securities
- p. Prepaid access
- q. Residential mortgage
- r. Security futures products
- s. Stocks
- t. Swap, hybrid or other derivative
- z. Other (specify type in space provided)

Item 45 Product types involved in suspicious activity: Check all Item 45 boxes that apply to record the product type(s) involved in the suspicious activity. Option 45f "Forex transactions" includes all foreign exchange transactions both on and off-exchange, including futures and options on foreign exchange. Option 45g "Futures/Options on futures" includes futures and options on any "commodity," as that term is defined in Section 1a(4) of the Commodity Exchange Act, including broad-based security indexes. Option 45s "Swap, hybrid or other derivative" includes all derivatives not included above including those traded over-the-counter and off-exchange. If the product type is not covered by options 45a through 45s, check box 45z "Other (list below)" and enter a brief description in the associated text field. If necessary provide a more detailed product type (such as commodity futures contracts, options on commodity futures contracts, commodity options, and OTC agricultural trade options) in Item 48 "Product/instrument description" or in Part V. If there are multiple product types not covered by Item 45, record one in Item 45z "Other (List below)" and all others in Part V.

46. Were any of the following instrument type(s)/payment mechanism(s) involved in the suspicious activity? Check all that apply:

- a. Bank/cashier's check
- b. Foreign currency
- c. Funds transfer
- d. Gaming instruments
- e. Government payment
- f. Money orders
- g. Personal/Business check
- h. Travelers checks
- i. U.S. Currency
- z. Other (specify type in space provided)

Item 46 Instrument types involved in suspicious activity: Check all Item 46 boxes that apply to record the instrument type(s) involved in the suspicious activity. If the instrument type is not covered by options 46a through 46i, check box 46z "Other (List below)" and enter a brief description in the associated text field. If necessary provide a more-detailed description of the instrument type in Part V. If there are multiple instrument types not covered by Item 46, record one in Item 46 "Other (List below)" and all others in Part V.

47. Commodity type (if applicable)

Item 47 Commodity type: If a commodity is involved in the suspicious activity, record the commodity type in Item 47. Multiple Item 47 fields should be completed if multiple commodity types are involved in the suspicious activity.

48. Product/Instrument description (if needed) (multiple entries up to 99)

Item 48 Product description: Provide a description of the product recorded in Item 45 or instrument recorded in Item 46 if necessary for a more-complete understanding of the suspicious activity. Multiple Item 48 fields should be completed if multiple products or instruments requiring a description are involved in the suspicious activity.

49. Market where traded

Item 49 Market where traded: Enter in Item 49 the three to five-letter code for the market where a commodity recorded in Items 45 or 47 was traded. Multiple Item 49 fields should be completed if multiple markets are involved in the suspicious activity. Use only the ISO 10383 Exchange/Market Identifier Codes (MIC) found at <http://www.iso15022.org/MIC/homepageMIC.htm>.

50. CUSIP number

Item 50 CUSIP® number: Enter in Item 50 the CUSIP® (Committee on Uniform Securities Identification Procedures) number of any securities products such as stocks and bonds involved in the suspicious activity. Multiple Item 50 fields should be completed if there are multiple CUSIP numbers for multiple securities products involved in the suspicious activity.

----- Part III Information about Financial Institution Where Activity Occurred -----

Part III records information about the financial institution(s) where the suspicious activity occurred. Complete a separate Part III record on each financial institution involved in the suspicious activity. If box 1d "Joint report" is checked there must be two or more Part III records in the FinCEN SAR, one for the Part IV filing institution or filer subsidiary and one for each joint filer. If a financial institution recorded in Part III has branches involved in the suspicious activity, record the branch information in Items 68 through 74. Information for up to 99 branches can be recorded in a single FinCEN SAR. A branch is a location (such as an office or ATM) owned by the financial institution but located separately from the financial institution's headquarters. If a reporting financial institution has agents where the suspicious activity occurred, a separate Part III must be prepared on each agent. An agent is an independent financial institution (such as a supermarket that sells money orders or an independent insurance agent) that has a contractual relationship with the reporting financial institution to conduct financial transactions. Do not place agent information in branch fields. Generally, a branch operates under the same TIN as the financial institution. An agent has a TIN different from the financial institution. Financial institution as used in Part III includes individuals acting as sole proprietorship financial institutions using their personal Social Security Number (SSN) or Individual Taxpayer Identification Number (ITIN).

*51. Type of financial institution

- a. Casino/Card club
- b. Depository institution
- c. Insurance company
- d. MSB
- e. Securities/Futures
- f. Loan or Finance Company
- g. Housing GSE
- z. Other (specify type of institution in space provided)

Item *51 - Type of financial institution: Select the appropriate type of financial institution that best describes the financial institution recorded in Item 51. If none of those options apply, select "Other" and enter a brief description in the associated text field. If necessary, include a more-detailed description in Part V.

NOTE: If the financial institution is a dealer in precious metals, stones, or jewels, select option "Other" and enter "DEALER IN PRECIOUS METALS STONES JEWELS" in the associated text field.

*52. Primary Federal Regulator

- a. CFTC
- b. Federal Reserve
- c. FDIC
- d. IRS
- e. NCUA
- f. OCC
- g. SEC
- h. Not Applicable

Item *52 Primary federal regulator: Select the appropriate option to identify the primary federal regulator or BSA examiner of the financial institution recorded in Part III. If more than one regulator option could apply, enter the code for the regulator that has primary responsibility for enforcing compliance with the BSA. If Item 51 option "Casino/Card Club," "Insurance Company," or "MSB" was selected, the Item 52 entry must be "Internal Revenue Service (IRS)." If the institution recorded in Part III is subject to U.S. law and none of the other codes apply, select option "Internal Revenue Service (IRS)." If the institution recorded in Part III is not subject to U.S. law, then select option "Not Applicable."

53. If item 51a is checked, indicate type of gaming institution (*check only one*)

- a. State licensed casino
- b. Tribal authorized casino
- c. Card club
- z. Other (specify type of gaming institution in space provided)

Item 53 Gaming institution type: If option 51a was selected indicating the financial institution is a gaming institution such as a casino or card club, record the type of gaming institution by checking the appropriate box. If none of the options 53a through 53c are appropriate, check box 53z "Other" and provide a brief description in the associated text field. If necessary, include a more detailed description in Part V.

54. If item 51e is checked, indicate type of Securities and Futures institution or individual where activity occurred - check the boxes of all types that apply to this report.

- a. Clearing broker – securities
- b. Execution-only broker securities
- c. Futures commission merchant
- d. Holding company
- e. Introducing broker - commodities
- f. Introducing broker - securities
- g. Investment adviser
- h. Investment company
- i. Retail foreign exchange dealer
- j. Self-clearing broker-securities
- k. Subsidiary of financial/bank holding company
- z. Other (specify type of institution or individual in space provided)

Item 54 Securities and futures type: If option 51e was checked indicating the financial institution is part of the securities and futures industries, check all boxes that apply to the reported suspicious activity. If none of options 54a through 54k apply, check box 54z "Other" and record a brief description of the type in the associated text field. Examples of this are commodity pool operator or commodity trading adviser. If necessary, include a more-detailed description in Part V.

55. Financial institution identification number

- a. Central Registration Depository (CRD) number
- b. Investment Adviser Registration Depository (IARD) number
- c. National Futures Association (NFA) number
- d. Research, Statistics, Supervision, and Discount (RSSD) number
- e. Securities and Exchange Commission (SEC) number
- f. National Association of Insurance Commissioners (NAIC Code)
- g. Mortgage (NMLS ID)
- z. Identification number

Item 55 Financial institution identification number: Select the appropriate option if the financial institution recorded in Part III has a Central Registration Depository (CRD) number, an Investment Adviser Registration Depository (IARD) number, a National Futures Association (NFA) number, a Research Statistics Supervision Discount (RSSD) number, National Association of Insurance Commissioners (NAIC Code), Mortgage (NMLS ID) or a Securities and Exchange Commission (SEC) Reporting File Number (RFN). Do not enter an SEC Central Index Key (CIK) number in place of the RFN. Record the number in field 55h. See General Instruction 8 for information on entering identifying numbers.

56. Financial institution's role in transaction (if applicable)

- a. *(check if)* Selling location

- b. *(check if)* Paying location
- c. *(check if)* Both a & b

Item 56 Financial institution role in transaction: Check the box "Selling location" if the customer purchased at the Part III financial institution the products or instruments recorded in Items 45 or 46. Check the box "Paying location" if the customer received payment from the Part III financial institution for the products or instruments recorded in Items 45 or 46. Check the box "Both" if the Part III financial institution was both a paying and selling location for the products or instruments recorded in Items 45 or 46.

Note: Item 56 generally applies to institutions such as MSB's or depository institutions through which the subject conducted transactions involving wire transfers, traveler's checks, money orders, or like products/financial instruments."

*57. Legal name of financial institution

- a. *(check if)* unknown

Item 57 Legal name of financial institution: Enter the legal name of the financial institution as recorded on articles of incorporation or other documents establishing the institution. Record as the legal name the full name of an individual, such as a sole proprietorship, acting as a financial institution. Enter the individual's name in (first name) (middle name) (last name) or equivalent format, e.g. John Jacob Doe or Richard R. Roe II, etc. Check box 57a "Unknown" if the legal name is unknown and leave Item 57 blank.

58. Alternate name, e.g., AKA if individual; DBA/trade name if entity

Item 58 Alternate name: If the financial institution recorded in Item 58 has a separate doing business as (DBA) name, enter that name here. If an individual recorded in Item 58 has a separate also known as (AKA) name, enter that name here also. Do not include the acronyms DBA or AKA with the alternate name.

* 59. TIN

- a. *(check if)* unknown

Item 59 - TIN: Enter the Taxpayer Identification Number (TIN), either U.S. or foreign, of the financial institution or individual recorded in Item 57. See General Instruction 8 for information on entering identifying numbers. Check box 59a "Unknown" if the TIN is unknown and leave Item 59 blank.

60. TIN type

- a. EIN
- b. SSN-ITIN
- c. Foreign

Item 60 TIN type: Select the option for the type of TIN entered in Item 59. If the TIN in Item 59 is unknown and the Item 57 financial institution has a U.S. address, select TIN Type option "EIN" if the financial institution is an entity and "SSN-ITIN" if the financial institution is an individual. If the financial institution has a foreign address and the TIN is unknown, select "Foreign."

Items *61 - *65 Financial institution address items: Enter the financial institution's permanent street address, city, two or three letter state/territory/province code (U.S./Canada/Mexico only), ZIP Code or foreign postal code, and two letter country code. If an address item is unknown, leave that item blank and check the item's "Unknown" box. Leave Item 63 State blank if the state is unknown or the country is not the U.S. or a U.S. Territory, Canada, or Mexico. See General Instruction 6 and the Part III introductory instructions for additional information on entering address data.

*61. Address

- a. *(check if) unknown*

*62. City

- a. *(check if) unknown*

63. State

*64. ZIP/Postal Code

- a. *(check if) unknown*

*65. Country

66. Internal control/file number

Item 66 Internal control/file number: Enter the internal control number or file number, if applicable, assigned to the FinCEN SAR by the financial institution. This number should be unique to the FinCEN SAR if possible, allowing interested parties such as law enforcement or the financial institution to reference the FinCEN SAR without committing a potentially illegal disclosure of FinCEN SAR data.

67 Loss to financial institution *(if applicable)*

Item 67 Loss to financial institution: If the financial institution has suffered a loss because of the suspicious activity, record the amount of loss in Item 67. If some losses are known and other losses unknown, enter the total of known losses as of the date of filing. If the FinCEN SAR is a continuing FinCEN SAR because box 1c was checked, enter the loss amount for the current FinCEN SAR in Item 67 and record in Part V the total aggregated losses for all FinCEN SARs filed on the suspicious activity. The amount entered in this field cannot be zero and cannot be greater than the amount in Item 29 "Amount involved in this report." See General Instruction 10 for information on entering amounts.

68. Branch's role in transaction *(if applicable)*

- a. *(check if) Selling location*
b. *(check if) Paying location*
c. *(check if) Both a & b*

Item 68 Branch's role: Check the box "Selling location" if the branch sold the products or instruments recorded in Items 45 or 46 to a customer. Check the box "Paying location" if a customer received payment from the branch for the products or instruments recorded in Items 45 or 46. Check the box "Both" if the Part III financial institution branch

was both a paying and selling location for the products or instruments recorded in Items 45 or 46. This item must be blank if no branch is involved in the suspicious activity. If multiple branches are involved in the suspicious activity, a separate Item 68 must be prepared for each branch.

Note: Item 68 generally applies to institutions such as MSB's or depository institutions through which the subject conducted transactions involving wire transfers, traveler's checks, money orders, or like products/financial instruments.

Items *69 and 71-74 Branch address items: See the instructions for Items *61 - *65, the Part III introductory instructions, and General Instruction 6 for information on entering branch address data. If a branch address item is unknown, leave that item blank. Item 74 "Country" cannot be blank if any other branch address information is recorded. If no branch was involved in the suspicious activity or the branch country is unknown, check box 69a and leave the branch address items blank. If multiple branches are involved in the suspicious activity, complete a set of branch address items for each branch.

69. Address of branch or office where activity occurred
 a. If no branch activity involved, check this box

70. RSSD number (*of the Branch*)

Item 70 RSSD number: Enter the RSSD (Research Statistics Supervision Discount) number of the branch, if known. If multiple branches are involved in the suspicious activity, complete Item 70 for each branch for which the RSSD number is known.

71. City

72. State

73. ZIP/Postal Code

*74. Country

----- Part IV Filing Institution Contact Information -----

Part IV records information about the lead financial institution, holding company, agency, or other entity that is filing the FinCEN SAR. There must be only one Part IV record in a FinCEN SAR. Do not include information about joint filers in a Part IV record. Joint filer information must be reported in a Part III record. Financial institution as used in Part IV includes individuals acting as sole proprietorship financial institutions using their personal Social Security Number (SSN) or Individual Taxpayer Identification Number (ITIN).

*75. Primary Federal Regulator (*instructions specify banking agencies, SEC, CFTC, IRS*)

- a. Commodities Futures Trading Commission (CFTC)
- b. Federal Reserve Board (FRB)
- c. Federal Deposit Insurance Corporation (FDIC)
- d. Internal Revenue Service (IRS)
- e. National Credit Union Administration (NCUA)
- f. Office of the Comptroller of the Currency (OCC)
- g. Securities and Exchange Commission (SEC)
- h. Federal Housing Finance Agency (FHFA)

- z. Not Applicable.

Item *75 Primary federal regulator: Select the appropriate option from the drop-down list to identify the Primary Federal Regulator or BSA Examiner of the filing institution. If more than one regulator option could apply, select the regulator that has primary responsibility for enforcing compliance with the BSA. If Item 79 option "Casino/Card Club," "Insurance Company," or "MSB" is selected, the Item 75 entry must be "Internal Revenue Service (IRS)." If the financial institution filing the FinCEN SAR is subject to U.S. law and none of the other codes apply, the entry must be "Internal Revenue Service (IRS)." If the FinCEN SAR is being filed by a government agency or if the financial institution filing the FinCEN SAR is not subject to U.S. law, the entry must be "Not Applicable."

*76. Filer name (*Holding company, lead financial institution, or agency, if applicable*).

Item *76 Filer name: Enter the legal name of the filing institution as recorded on articles of incorporation or other documents establishing the institution. Enter the full name of the filer if the filer is an individual, such as a sole proprietorship, acting as a financial institution. If an individual's name is recorded, enter the name in (first name) (middle name) (last name) or equivalent format, e.g. John Jacob Doe or Richard R. Roe II, etc.

*77. TIN

Item *77 - TIN: Enter the Taxpayer Identification Number (TIN), either U.S. or foreign, of the financial institution or individual recorded in Item 76. See General Instruction 8 for information on entering identifying numbers.

*78. TIN type

- a. EIN
- b. SSN/ITIN
- c. Foreign

Item *78 - TIN type: Record the type of TIN entered in Item 77 by selecting the appropriate option.

*79. Type of financial institution

- a. Casino/Card club
- b. Depository institution
- c. Insurance company
- d. MSB
- e. Securities/Futures
- f. Loan or Finance Company
- g. Housing GSE
- z. Other (*specify type of institution in space provided*)

Item *79 - Type of financial institution: Select the appropriate type of financial institution that best describes the filing institution recorded in Item 76. If none of those options apply, select "Other" and enter a brief description in the associated text field. If necessary, include a more-detailed description in Part V.

NOTE: If the financial institution is a dealer in precious metals, stones, or jewels, select option "Other" and enter "DEALER IN PRECIOUS METALS STONES JEWELS" in the associated text field.

80. Type of Securities and Futures institution or individual filing this report - check the boxes of all types that apply to this report.

- a. Clearing broker - securities
- b. CPO/CTA
- c. Execution-only broker securities
- d. Futures commission merchant
- e. Holding company
- f. Introducing broker - commodities
- g. Introducing broker - securities
- h. Investment adviser
- i. Investment company
- j. Retail foreign exchange dealer
- k. Self-clearing broker-securities
- l. SRO Futures
- m. SRO Securities
- n. Subsidiary of financial/bank holding company
- z. Other (specify type of institution or individual in space provided)

Item 80 - Securities and futures type: If option 80e "Securities/Futures" was selected, check all boxes that apply to indicate the type of securities and futures institution that is filing the FinCEN SAR. If none of options 80a through 80n apply, check box 80z "Other" and record a brief description of the type in the associated text field. If necessary, include a more-detailed description in Part V.

81. Filing institution identification number

- a. Central Registration Depository (CRD) number
- b. Investment Adviser Registration Depository (IARD) number
- c. National Futures Association (NFA) number
- d. Research, Statistics, Supervision, and Discount (RSSD) number
- e. Securities and Exchange Commission (SEC) number
- f. National Association of Insurance Commissioners (NAIC Code)
- g. Mortgage (NMLS ID)
- z. Identification number

Item 81 - Filing institution identification number: See instructions for Item 55.

Items 82-86 - Address: See instructions for Items 61 through 65.

*82. Address

* 83. City

*84. State

* 85. ZIP/Postal Code

* 86. Country

87. Alternate name, e.g., AKA if individual; DBA/ trade name if entity. See instructions for Item 58.

88. Internal control/file number: See instructions for Item 66.

89. LE contact agency

Item 89 - LE contact agency: Enter the name of the law enforcement agency, if any, which has been informed of the suspicious activity.

NOTE: If more than one LE agency has been contacted about the suspicious activity, record the information on one agency in Items 89-92 and the information on additional agencies in Part V.

90. LE contact name

Item 90 - LE contact name: Enter the name of the person contacted at the law enforcement agency.

91. LE contact phone number

Item 91 - LE contact phone number: Enter the law enforcement contact telephone number. See General Instruction 7 for information on entering telephone numbers.

91a. Extension (*if any*)

Item 91a - Extension: Enter the extension, if any, of the law enforcement contact telephone number

92. LE contact date

Item 92 – LE contact date: Enter the most-recent date the law enforcement agency was contacted about the suspicious activity. If the agency was contacted on multiple dates, record the earlier contact dates in Part V. Discrete filers will use the format MM/DD/YYYY while batch filers will use the format YYYYMMDD.

*93. Filing institution contact office

Item 93 - Filing institution contact office: Enter the name of the filing institution contact office where additional information about the FinCEN SAR or supporting documentation can be requested. If the FinCEN SAR is jointly filed, enter in Part V the contact office and telephone number information for all Part III joint filers.

***94. Filing institution contact office phone number including area code**

- a. Extension, if any

Item 94 - Filing institution contact office phone number: Enter the contact office telephone number. See General Instruction 7 for additional instructions on entering telephone numbers.

Item 94a - Extension: Enter the extension, if any, of the contact office telephone number.

***95. Date filed**

Item 95 - Date filed: Enter the date the FinCEN SAR is filed. This date will be entered automatically when a discrete FinCEN SAR is electronically filed. Batch filers will report this date in YYYYMMDD format.

----- * Part V Suspicious Activity Information – Narrative -----

The narrative section of the report is critical to understanding the nature and circumstances of the suspicious activity. The care with which the narrative is completed may determine whether the described activity and its possible criminal nature are clearly understood by investigators. Filers must provide a clear, complete, and concise description of the activity, including what was unusual or irregular that caused suspicion. This description should encompass the data provided in Parts I through III, but should include any other information necessary to explain the nature and circumstances of the suspicious activity. Filers should provide any information the filers believe necessary to better enable investigators to understand the reported suspicious activity. Narratives must be completed in English. Filers should use the following checklist as a guide for preparing the narrative:

- If filers have additional information pertaining to items in Parts I through IV this information should be recorded in the narrative and referenced to the item number.
- If this report is a corrected or amended report, complete the report in its entirety with whatever corrections or amendments were required. Describe the corrections or amendments at the beginning of the narrative.
- If this report is a continuing report, describe the circumstances surrounding the suspicious activity for the 90-day period encompassing the report. Include information from prior FinCEN SAR narratives only when it is necessary for an understanding of the nature and circumstances of the suspicious activity. Never include the entire narratives of the prior FinCEN SARs.
- If any item in the report was insufficient for recording all item data held by the filer, or if an item's instructions require entry of additional data or explanation in the narrative, record the additional data referenced by item number in the narrative.
- Information provided in other sections of the FinCEN SAR need not be repeated in the narrative unless necessary to provide a clear and complete description of the suspicious activity.
- Describe the conduct or transaction(s) that caused suspicion. If appropriate, this description should be chronological when the activity involves multiple instances or encompasses more than one day.
- Explain whether any transaction(s) involved were completed or only attempted.
- Explain who benefited and how they benefited, financially or otherwise, from the activity.
- Describe all supporting documentation and retain the documentation for five years. DO NOT include supporting documentation with the FinCEN SAR. (See General Instruction 6.)
- If the FinCEN SAR is jointly-filed, name all joint filers and describe the nature of supporting document held by the joint filers. Provide the contact office name and telephone number for each joint filer.
- Describe and retain any evidence of cover-up or evidence of an attempt to deceive federal or state examiners or others

- Describe and retain any admission or explanation of the activity or transaction(s) provided by the subject(s), witness(s), or other person(s), including to whom and when it was given.
- Indicate where the suspicious activity took place, e.g. branch, cage, gaming pit, agent location, etc.
- Indicate whether the suspicious activity is an isolated incident or related to other activity.
- Indicate whether any U.S. or foreign currency or other negotiable instruments were involved. If foreign currency or other foreign instruments, provide the foreign amount, currency name, and country of origin.
- Indicate if there is any litigation related to the activity by specifying the name of the litigation and court where the action is pending.
- Describe the nature of losses and recoveries related to the suspicious activity, including aggregated losses and recoveries in continuing activity.
- Identify the names of financial institutions associated with account numbers when the financial institution TINs were unknown.
- If the subject is a foreign national provide all available information on the subject's passport(s), visa(s), and other identification. Include identifying data such as issuing date, country, document numbers, issuing authority, and nationality.
- If the suspicious activity involves transfers of funds to or from a foreign country or currency exchanges involving foreign currencies, identify the foreign currency, country of issue, and the source or destination of the funds.
- If a subject involved in the suspicious activity has an insider relationship with a financial institution, describe the subject's position with the financial institution and how that position related to the suspicious activity.
- Provide information on the victims of the suspicious activity only when it is necessary for a complete understanding of the activity. DO NOT record victim information in a Part I Subject Information record.
- Provide information about the financial institution's business policies and practices only if it is necessary for a complete understanding of the suspicious activity. DO NOT include legal disclaimers in the narrative.
- Do not include tabular data in a FinCEN SAR narrative. Such data should be reported in an appropriate comma separated values attachment.

Filers can include with a FinCEN SAR an attachment containing tabular data (such as transaction data) that provides additional suspicious activity information not suitable for inclusion in the narrative. This file must be an MS Excel-compatible comma separated value (CSV) file with a maximum size of 1 megabyte. Discrete FinCEN SAR filers can attach this file by clicking the "Add Attachment" button on the discrete FinCEN SAR header page and following the instructions provided. Batch filers must follow the instructions in Attachment D – Batch Attachments to add CSV files to a batch file.

10.Attachment D – Secure Data Transfer Mode Filers

FinCEN provides the ability for filers to submit the FinCEN SAR XML batch file securely via the Internet using a VPN device or Connect:Direct software. This method of filing is referred to as Secure Data Transfer Mode (SDTM). SDTM allows for a secure, system to system mechanism for transferring batch submissions from your organization's internal server to the BSA E-Filing server. The batch submission process can be automated such that user intervention/involvement is minimized. There is no interaction with the BSA E-Filing system web site for the upload of the batch file but the BSA E-Filing system web site is used to track the status of the submissions.

For filers using this option for filing, SDTM filers can submit a single file containing the FinCEN SAR XML batch data. The file naming convention is as follows:

Submission type: SARXST

Date/Time: This will be a date-time stamp to guarantee filename uniqueness

- Year = YYYY
- Month = MM
- Day = DD
- Hour = hh
- Minute = mm
- Second = ss

Organization name: Custom naming by the submitting organization (e.g. "ABCPreparingFirm")

Extension: xml

Example FinCEN SAR XML batch file name: SARXST.20170609153015.ABCPreparingFirm.xml

Corresponding FinCEN SAR XML batch Acknowledgement file name: This file name will match the corresponding input FinCEN SAR XML batch file name with the text "*.ACKED" appended to the end.

For example: SARXST.20170609153015.ABCPreparingFirm.xml.ACKED

For more information on how to setup an SDTM connection, please refer to the SDTM Requirements documentation available on the BSA E-Filing System secure side, or you may contact the BSA E-Filing Help Desk at 1-866-346-9478 or via email at BSAEFilingHelp@fincen.gov. The Help Desk is available Monday through Friday from 8 a.m. to 6 p.m. EST. Please note that the Help Desk is closed on Federal holidays.

11.Attachment E – Supporting Documentation (Attachments)

Institutions filing electronic FinCEN Suspicious Activity Reports (FinCEN SAR) may, but are not required to, attach a Microsoft Excel-compatible comma separated values (CSV) file (no larger than 1 MB) providing details in tabular form of transactions subject to the suspicious activity discussed in Part V “Narrative Description” of the FinCEN SAR.

NOTE: Please be advised that when entering data into an Excel spreadsheet prior to saving it as a comma separated (.CSV) file, the default behavior for numeric data entered into cells is to convert numeric values over 11 characters into scientific notation. For example, the value of 123456789123 is converted to 1.23457E+11 after entry. When the Excel spreadsheet is saved to a comma separated (.CSV) file, this visible format is retained and when opened the entire original number is not displayed, 123456789123, but rather 1.23457E+11. To avoid this behavior, please ensure that your workbook cells are formatted as text prior to entering data in the cell. This can be accomplished by selecting the column, right clicking the mouse and selecting Format Cells, and then selecting Text under Category, and then OK. This must be done before entering the data, not after.

While the BSA E-Filing System limits the number of attachments for a single FinCEN SAR to one (1) CSV file, batch filers must abide by the following instructions in order to submit attachments for one or more FinCEN SAR within their batch file:

1. Record the supporting document file name for each FinCEN SAR XML within the batch

Record the <ActivitySupportDocument> element, along with the <OriginalAttachmentFileName> sub-element, for each FinCEN SAR Activity within the XML batch associated with an attachment. Record the full name of the corresponding CSV file within the OriginalAttachmentFileName element.

2. Record the counts for the total number of attachments and FinCEN SAR XML activities with attachments with the batch

Record the following attributes and counts within the EFilingBatchXML element in the XML batch:

- ActivityAttachmentCount. The count of all <Activity> elements in the batch where the <OriginalAttachmentFileName> element is recorded with a value referencing the file name of the FinCEN SAR attachment
- AttachmentCount. The count of all <OriginalAttachmentFileName> elements in the batch that contain a value referencing the file name of the FinCEN SAR attachment

3. Include all attachments in a single zip file with the FinCEN SAR XML activity sequence number appended to each attachment file name

- Create a zip file composed of all attachments. When naming the zip file, be sure to use a descriptive file name to help you identify which FinCEN SAR batch your attachment zip file is associated with.
- For each csv attachment file within the zip file, append the corresponding sequence number (i.e. “SeqNum” value associated with the FinCEN SAR Activity in the XML batch as follows:

<FinCEN SAR Activity SeqNum>_<OriginalAttachmentFileName>.csv

For example:

1_BankofUSBatchAttachment.csv

The above example indicates that within the FinCEN SAR XML batch, Activity SeqNum=“1” contains the <OriginalAttachmentFileName> element with the value of “BankofUSBatchAttachment.csv”.

4. Attach the attachments zip file to the FinCEN SAR XML Batch Form prior to submission

Once all required fields are complete and your FinCEN SAR XML batch has been attached to the FinCEN SAR XML Batch Form, locate the Add File button for attachments in order to add your attachment zip file to the FinCEN SAR XML Batch Form. Once the attachment file is attached, you may sign the FinCEN SAR Batch Form with your PIN, save, and submit.

ATTENTION: Secure Data Transfer Mode (SDTM) Filers

Filers who transmit the FinCEN SAR XML batch data via secure server-to-server connection may submit a single ZIP file containing the FinCEN SAR XML batch file along with the corresponding attachment zip file. This single ZIP file is composed of one FinCEN SAR XML batch file and one attachment ZIP file. The attachment ZIP file shall follow the same attachment requirements described above. The single ZIP file name must start with "SARXST." and end with ".ZIP". For example: SARXST.SARXML_batch.ZIP. FinCEN SAR XML SDTM batch files without any attachment shall follow the naming convention described in Attachment D of this guide.