

# GUIDANCE FOR APPLICANTS REQUESTING TO TREAT/DISPOSE OF PCBS USING INCINERATION OR AN ALTERNATIVE METHOD

## A WALK-THROUGH OF THE APPLICATION PROCESS

Office of Resource Conservation and Recovery  
Office of Land and Emergency Management  
U.S. Environmental Protection Agency

October 2019  
EPA530-R-19-005



## **Disclaimer**

This document is intended to be used as an informal reference, and as such, is not a complete statement of all applicable polychlorinated biphenyl (PCB) requirements. This document does not replace or supplant the requirements of the Toxic Substances Control Act (TSCA) PCB regulations. Please refer to the PCB regulations at 40 CFR part 761 for specific regulatory requirements. Also, as indicated by the use of non-mandatory language such as “guidance,” “may,” “should,” and “can,” these materials identify policies and provide suggestions and do not create any new legal obligations or limit or expand obligations under any federal, state, tribal, or local law.

## **Paperwork Reduction Act Notice**

The public burden for using this guidance when applying to treat/dispose of PCB waste using incineration or an alternative method, which is approved under OMB Control No. 2070-0211, is estimated to average 40 hours per applicant. This average is the combination of reading this guidance (estimated to be 27.5 hours per applicant) and filling out the checklists in the appendices of this guidance (estimated to be 12.5 hours per applicant). However, the overall burden on those applying to treat/dispose of PCB waste using incineration or an alternative method is expected to be reduced significantly because this guidance will streamline the approval process. This is captured in a separate ICR, EPA ICR No. 1446.12 (PCBs, Consolidated Reporting and Recordkeeping Requirements found in docket EPA-HQ-OPPT-2017-0647). This document may be useful for those applying to treat/dispose of PCB waste using incineration or an alternative method under 40 CFR 761.70 or 40 CFR 761.60(e).

An agency may not conduct or sponsor, and a person is not required to respond to, a collection of information unless it displays a currently valid OMB control number.

Those treating/disposing of PCB waste using incineration or an alternative method may submit documentation in accordance with this guidance, or as specified in the corresponding regulation. Comments may be submitted to EPA electronically through <http://www.regulations.gov> or by mail to: EPA Docket Center, Environmental Protection Agency, Mail Code 28221T, 1200 Pennsylvania Ave., NW, Washington, DC 20460. You can also send comments to OMB, addressed to “OMB Desk Officer for EPA” and referencing OMB Control No. 2070-0211 (EPA ICR No. 2596.01) via email to [oir\\_submission@omb.eop.gov](mailto:oir_submission@omb.eop.gov). Include docket ID No. EPA-HQ-OLEM-2018-0305 and OMB control number 2070-0211 (EPA ICR No. 2596.01) in any correspondence, but do not submit any other information (e.g., forms, reports, etc.) to these addresses.

### ***Privacy Act Statement***

*None of the information collected for the PCB Program regarding this guidance is considered Personally Identifiable Information (PII) or Confidential Business Information (CBI).*

## Notice

This guidance document was developed by the U.S. Environmental Protection Agency's (EPA) Office of Resource Conservation and Recovery (ORCR) and was funded under EPA Contract No. EP-W-09-024 to update and combine two guidance documents (*Draft Guidelines for Permit Applications and Demonstration Test Plans for PCB Incinerators*, and *Draft Guidelines for Permit Applications and Demonstration Test Plans for PCB Disposal by Non-Thermal Alternative Methods*). For questions about this guidance document, please contact [ORCRPCBs@epa.gov](mailto:ORCRPCBs@epa.gov) or refer to EPA's Regional and Headquarters PCB contact information on EPA's PCB website at [www.epa.gov/pcbs/program-contacts](http://www.epa.gov/pcbs/program-contacts).

# TABLE OF CONTENTS

Section	Page
List of Figures .....	vii
List of Tables.....	vii
Acronyms and Abbreviations.....	ix
Glossary .....	xii
1 Introduction .....	1
1.1 Benefits of this Guidance .....	1
1.2 Organization and How to Use .....	2
2 Summary of Relevant 40 CFR part 761 Regulations .....	4
2.1 General.....	4
2.2 Approval Authority.....	4
2.3 Incinerators.....	6
2.3.1 Liquid PCBs .....	6
2.3.2 Non-liquid PCBs.....	7
2.3.3 Maintenance of Data and Records .....	8
2.3.4 Approval of Incinerators.....	8
2.4 Alternative Methods of Disposal .....	8
2.4.1 Alternative Thermal Destruction Technologies.....	9
2.4.2 Alternative Non-Thermal Destruction/Removal Technologies .....	9
2.5 Other Regulations .....	9
2.5.1 High Efficiency Boilers .....	9
2.5.2 Scrap Metal Recovery Ovens and Smelters .....	10
3 Basic Approval Procedures for the Treatment/Disposal of PCBs Using Incineration or an Alternative Technology .....	11
3.1 Establish Communications with the EPA Approval Writer.....	11
3.2 Research and Development .....	11
3.3 Submittal of Operating Approval Application and Test Plan .....	13
3.4 EPA Review of Operating Approval Application and Test Plan.....	13
3.5 EPA Approval of Test Plan .....	14
3.6 Conducting a Test .....	14
3.7 Submittal of Test Report.....	14
3.8 EPA Review of the Test Report.....	14
3.9 EPA Issues an Operating Approval .....	15
4 Contents of Operating Approval Application .....	16
4.1 Preliminary Steps to an Approval Application .....	16
4.1.1 Early Communication .....	16
4.1.2 Criteria .....	16
4.1.3 Other Important Information for Development of an Approval Application.....	18
4.1.4 Research and Development Applications.....	19
4.1.5 Submitting Confidential Business Information (CBI).....	20
4.1.6 Mobile Treatment Applications .....	21
4.2 Contents of an Operating Approval Application .....	21
4.2.1 Transmittal Letter.....	21
4.2.2 Cover Page .....	22
4.2.3 Approval Application Section I - Summary.....	24
4.2.4 Approval Application Section II - Company .....	

	Organization/Structure/Personnel .....	24
4.2.5	Approval Application Section III - Waste Description .....	25
4.2.6	Approval Application Section IV - Process Engineering Description .....	25
4.2.6.1	General Information.....	25
4.2.6.2	Waste Feed System.....	26
4.2.6.3	Automatic Waste Feed Cutoff System .....	26
4.2.6.4	PCB Destruction/Removal System.....	27
4.2.6.5	Pollution Control System .....	29
4.2.6.6	Compendium of All Process Operating Parameters .....	30
4.2.7	Approval Application Section V - Monitoring and Sampling Plan.....	30
4.2.7.1	Monitoring and Sampling Plan for Incineration and Alternative Thermal Destruction Technologies .....	32
4.2.7.2	Monitoring and Sampling Plan for Alternative Non-Thermal Destruction/Removal Technologies.....	41
4.2.8	Approval Application Section VI - Monitoring Procedures .....	45
4.2.9	Approval Application Section VII - Sampling and Analysis Procedures .....	45
4.2.10	Approval Application Section VIII - Data Recordkeeping and Reporting .....	46
4.2.11	Approval Application Section IX - By-Product Waste Handling and Treatment/Disposal .....	47
4.2.12	Approval Application Section X - Inspection Procedures .....	47
4.2.13	Approval Application Section XI - Spill Prevention, Control, and Countermeasures Plan.....	47
4.2.14	Approval Application Section XII - Safety Plan .....	48
4.2.15	Approval Application Section XIII - Training Plan .....	49
4.2.16	Approval Application Section XIV - Test Plan Summary .....	50
4.2.17	Approval Application Section XV - Test Data or Engineering Performance Calculations .....	50
4.2.18	Approval Application Section XVI - Other Permits and Approvals .....	50
4.2.19	Approval Application Section XVII - Schedule of Events .....	51
4.2.20	Approval Application Section XVIII - Quality Assurance Project Plan.....	51
4.2.21	Approval Application Section XIX - Standard Operating Procedures.....	53
4.2.22	Approval Application Section XX - Closure Plan.....	53
4.3	Financial Assurance Documentation .....	54
4.3.1	Closure Financial Assurance .....	54
4.3.2	Third Party Liability Financial Assurance .....	56
4.3.3	Maintenance of Financial Assurance.....	56
4.3.4	Release of Financial Assurance Obligation.....	56
4.3.5	Transfer of Ownership or Operational Control.....	57
5	Test Plans.....	58
5.1	General.....	58
5.1.1	The Purpose of the Test and General Approach .....	59
5.2	Contents of a Test Plan .....	60
5.2.1	Test Plan Section I - Summary.....	61
5.2.2	Test Plan Section II - Project Organization.....	63
5.2.3	Test Plan Section III - Treatment Process and Facility Information .....	63
5.2.4	Test Plan Section IV - Operating Parameters.....	63
5.2.5	Test Plan Section V - Monitoring and Sampling Plan.....	66

5.2.5.1	Pollutants and Parameters to be Monitored/Sampled during Tests for Incinerators or Alternative Thermal Destruction Technologies.....	68
5.2.5.2	Pollutants and Parameters to be Monitored/Sampled during Tests for Alternative Non-Thermal Destruction/Removal Technologies .....	69
5.2.6	Test Plan Section VI - Monitoring Procedures .....	70
5.2.7	Test Plan Section VII - Sampling and Analysis Procedures .....	70
5.2.8	Test Plan Section VIII - Emergency Procedures .....	72
5.2.9	Test Plan Section IX - Test Data Reporting .....	72
5.2.10	Test Plan Section X - Miscellaneous Tests .....	73
5.2.11	Test Plan Section XI - Waste Handling and Disposal .....	73
5.2.12	Test Plan Section XII - Test Schedule.....	73
5.2.13	Test Plan Section XIII - Quality Assurance Project Plan.....	75
5.2.14	Test Plan Section XIV - Standard Operating Procedures.....	76
6	Conducting and Monitoring a Test .....	77
6.1	Expected Responsibilities During the Test .....	77
6.1.1	EPA's Role .....	77
6.1.2	The Facility's Role.....	78
6.2	Preparing for the Test .....	78
6.3	Three Phases of a Test .....	79
6.3.1	Phase I: Start-up of the Treatment/Disposal Unit.....	79
6.3.2	Phase II: Treatment/Disposal of PCB Waste .....	80
6.3.3	Phase III: Shutdown of the Treatment/Disposal Unit.....	80
6.4	Completed Test .....	80
6.4.1	An Acceptable Test.....	81
6.4.2	Failed Test .....	81
7	Test Report .....	82
7.1	General.....	82
7.2	Contents of Test Reports .....	83
7.2.1	Transmittal Letter.....	83
7.2.2	Cover Page .....	83
7.2.3	Certification Letter .....	84
7.2.4	Test Report Section I - Summary.....	84
7.2.5	Test Report Section II - Process Operation.....	84
7.2.5.1	General Process Operation Information .....	84
7.2.5.2	Pollutants and Parameters Monitored/Sampled during Tests for Incinerators or Alternative Thermal Destruction Technologies.....	87
7.2.5.3	Pollutants and Parameters Monitored/Sampled during Tests for Alternative Non-Thermal Destruction/Removal Technologies .....	88
7.2.5.4	Deviations from the Test Plan.....	89
7.2.6	Test Report Section III - Test Results.....	89
7.2.7	Test Report Section IV - Monitoring and Sampling Procedures .....	90
7.2.8	Test Report Section V - Analytical Procedures .....	90
7.2.9	Test Report Section VI - Quality Assurance Summary.....	91
7.2.10	Test Report Section VII - Visits and Audits .....	91
7.2.11	Test Report Section VIII - Waste Handling and Disposal .....	91
7.2.12	Appendices .....	91
7.3	EPA Review of the Test Report.....	92
7.3.1	Criteria for Evaluating Test Results.....	92

7.3.2	Deficiencies in the Test Report.....	93
7.3.3	Incomplete or Failed Test.....	93
8	Approval Issuance and Renewal.....	95
8.1	Public Comment and Public Participation.....	95
8.2	Operating Approval Contents.....	95
8.2.1	Mobile vs. Fixed-Site Disposal Approvals.....	96
8.2.2	Compliance under an Operating Approval.....	96
8.2.3	Approval Modifications.....	97
8.3	Approval Renewal and Expiration.....	97
8.4	Approval Termination.....	98
9	References.....	99
	Appendix A: Sources for Additional Information.....	100
	Appendix B: Checklists for Completeness of Submittal.....	111
	Appendix C: Monitoring, Sampling, and Analysis Procedures.....	119
	Appendix D: Quality Assurance Project Plan Template.....	133
	Appendix E: Cleanup, Extraction, and Determinative Methods for PCB Aroclors, Homologs, and Congeners.....	146
	Appendix F: Example Checklists for Thermal and Non-Thermal Technologies for Use During the Test.....	150
	Appendix G: PCB Aroclors, Homologs, and Congeners.....	154

## LIST OF FIGURES

<b>Figure</b>	<b>Page</b>
1. Major Steps in the Operating Approval Process.....	12
2. Approval Application Cover Page Example.....	23
3. Example Schematic of Monitoring and Sampling Points for an Incinerator.....	34
4. Example Schematic of Monitoring and Sampling Points for a Thermal Desorber Unit.....	37
5. Example Schematic of Monitoring and Sampling Points for a Chemical Dechlorination Process.....	42
6. Test Plan Cover Page Example.....	62
7. Test Report Cover Page Example.....	85

## LIST OF TABLES

<b>Table</b>	<b>Page</b>
1. Summary of Relevant Approval Authorities.....	5
2. Suggested Format for an Approval Application.....	22
3. Example Summary of Monitoring Parameters for Incinerators.....	35
4. Example Summary of a Sampling Plan for Incinerators.....	36
5. Example Summary of Monitoring Parameters for an Alternative Thermal Destruction Technology.....	38
6. Example Summary of a Sampling Plan for an Alternative Thermal Destruction Technology.....	40
7. Example Summary of Monitoring Parameters for a Chemical Dechlorination Process.....	43
8. Example Summary of a Sampling Plan for a Chemical Dechlorination Process.....	44
9. Suggested Format for a Test Plan.....	61

10.	Example Summary of Test Parameters for an Incinerator .....	65
11.	Example Summary of Test Parameters for a Batch Chemical Dechlorination Process .....	66
12.	Example: Proposed Schedule for an Incineration Test.....	74
13.	Example: Proposed Schedule for an Alternative Method of Treatment/Disposal Test.....	75
14.	Suggested Format for the Test Report.....	83
15.	Example Test Results Summary for Incinerator or Alternative Thermal Destruction Technology .....	86
16.	Example Test Results Summary for an Alternative Non-Thermal Destruction/Removal Technology .....	87
A-1.	Outline of 40 CFR 761 .....	101
B-1.	Example Approval Application Checklist for Thermal and Non-Thermal Methods .....	113
B-2.	Example Checklist for a Test Plan.....	116
B-3.	Example Monitoring and Sampling Parameter Summary to be included in Test Plans for Incinerators or Alternative Thermal Destruction Process.....	117
B-4.	Example Monitoring and Sampling Parameter Supplement for an Alternative Non- Thermal Destruction Process.....	118
C-1.	Summary of Standard Stack Sampling/Monitoring Methods .....	124
E-1.	Summary of Extraction Methods for PCB Samples .....	147
E-2.	Summary of Cleanup Methods for PCB Samples.....	148
E-3.	Summary of Analytical Methods for PCB Samples .....	148
F-1.	Example Checklist for Thermal Alternative Methods for Use During the Test .....	151
F-2.	Example Checklist for Non-Thermal Alternative Methods for Use During the Test.....	153
G-1.	List of PCB Aroclors .....	156
G-2.	List of PCB Homologs.....	157
G-3.	List of PCB Congeners .....	158



## ACRONYMS AND ABBREVIATIONS

µg	Microgram
µg/L	Micrograms per liter
°C	Degrees Celsius
°F	Degrees Fahrenheit
ACFM	Actual cubic feet per minute
ACM	Actual cubic meter
APCD	Air pollution control device
ASTM	American Society for Testing and Materials
Atm	Atmosphere
ATSDR	Agency for Toxic Substances and Disease Registry
Btu	British thermal unit
CAA	Clean Air Act
CARB	California Air Resources Board
CASRN	Chemical abstracts service registry number
CB	Calibration blank
CBI	Confidential business information
CCS	Calibrated check standard
CE	Combustion efficiency
CEMS	Continuous emissions monitoring systems
CFM	Cubic feet per minute
CFR	Code of Federal Regulations
CGC	Capillary gas chromatography
cm	Centimeter
CO	Carbon monoxide
CO <sub>2</sub>	Carbon dioxide
CPR	Cardiopulmonary resuscitation
CWA	Clean Water Act
Demo	Demonstration
DOE	Department of Energy
DOI	Digital object identifier
DOT	Department of Transportation
DQO	Data quality objective
DRE	Destruction and removal efficiency
dscf	Dry standard cubic feet
dscm	Dry standard cubic meter
ECD	Electron capture detector
EIMS	Electron impact mass spectrometry
ELCD	Electrolytic conductivity detector
EPA	U.S. Environmental Protection Agency
ESA	Endangered Species Act
ESP	Electrostatic precipitator
FID	Flame ionization detector
g	Grams
GC	Gas chromatography
GC/ECD	Gas chromatography/Electron capture detector

GC/FID	Gas chromatography/Flame ionization detector
GC/MS	Gas chromatography/Mass spectrometry
GPC	Gel permeation chromatography
gpm	Gallon per minute
gr	Grains
HAP	Hazardous air pollutants
HAZWOPER	Hazardous Waste Operations and Emergency Response
HCl	Hydrochloric acid
HCl/Cl <sub>2</sub>	Hydrogen chloride/chlorine
HPLC	High performance liquid chromatography
HQ	Headquarters
HRGC	High resolution gas chromatography, also termed capillary GC
HRMS	High resolution mass spectrometry
ID	Inner diameter
IERL	Industrial Environmental Research Laboratory
in H <sub>2</sub> O	Inches of water
IR	Infrared
IRM	Information Resource Management
IUPAC	International Union of Pure and Applied Chemistry
kg	Kilogram
L	Liter
LCS	Laboratory control sample
LOC	Level of chlorination
LRMS	Low resolution, electron ionization mass spectrometry
m	Meter
MACT	Maximum Achievable Control Technology
MB	Method blank
mg	Milligram
mg/L	Milligrams per liter
mm Hg	Millimeters of mercury
mm	Millimeter
MODEF	Mineral oil dielectric fluid
MS	Mass spectrometry
NA	Not applicable
NAA	Neutron activation analysis
ND	Not detected
NDIR	Nondispersive infrared
NESHAP	National Emission Standards for Hazardous Air Pollutants
NHPA	National Historic Preservation Act
NIOSH	National Institute for Occupational Safety and Health
NMR	Nuclear magnetic resonance
NO <sub>x</sub>	Oxides of nitrogen
NPDES	National Pollutant Discharge Elimination System
NRC	Nuclear Regulatory Commission
NTIS	National Technical Information Service
O <sub>2</sub>	Oxygen
OLEM	Office of Land and Emergency Management
ORCR	Office of Resource Conservation and Recovery, an office within OLEM

OSHA	Occupational Safety and Health Act
PAH	Polycyclic aromatic hydrocarbons
PCB	Polychlorinated biphenyl(s)
PCDD	Polychlorinated dibenzo-p-dioxin
PCDF	Polychlorinated dibenzofuran
PCS	Pollution control system
PD	Percent difference
PDF	Portable document format
PE	Performance evaluation
PGC	Packed column gas chromatography
pH	Measure of acidity or alkalinity
PM	Particulate matter
POHC	Principal organic hazardous constituent
ppb	Parts per billion
PPE	Personal protective equipment
ppm	Parts per million
ppq	Parts per quadrillion
ppt	Parts per trillion
psi	Pounds per square inch
PT	Proficiency testing
QA	Quality assurance
QAPP	Quality assurance project plan
QC	Quality control
R&D	Research and development
RCRA	Resource Conservation and Recovery Act
RIA	Radioimmunoassay
RIS	Recovery internal standards
RPD	Relative percent difference
RTD	Resistance-thermal detector
SCFM	Standard cubic feet per minute
SDS	Safety data sheet
SIM	Selective ion monitoring
SIS	Surrogate internal standard
SOP	Standard operating procedures
SORS	Stop operations/repair system
SPCC	Spill prevention, control, and countermeasure
SVOC	Semi-volatile organic compound
SW	Solid waste
TBD	To be determined
TCDD	Tetrachlorodibenzodioxin
TCDF	Tetrachlorodibenzofuran
TEQ	Toxic equivalent
TLC	Thin layer chromatography
TSCA	Toxic Substances Control Act
VOC	Volatile organic compounds
VOST	Volatile organic sampling train

## GLOSSARY

As used in this document, all terms not defined herein have the meaning given to them in the Toxic Substances Control Act (TSCA), 15 U.S.C. 2601 *et seq.*, and 40 Code of Federal Regulations (CFR) part 761.

### **Accuracy**

The degree of agreement between an observed value and an accepted reference value. Accuracy includes a combination of random error (precision) and systematic error (bias) components that are due to sampling and analytical operations. Accuracy is monitored through the analysis of quality control (QC) samples.

### **Administrator**

See definition in [40 CFR 761.3](#).

### **Agency**

See definition in [40 CFR 761.3](#).

### **Analyte**

Chemical compound or element that is the subject of an analysis.

### **Approval**

A written authorization issued by Environmental Protection Agency (EPA) to implement the requirements of 40 CFR part 761. An approval incorporates applicable requirements in TSCA and the polychlorinated biphenyl (PCB) regulations, 40 CFR part 761, and establishes specific administrative, safety, and technical standards to which owners and operators of a treatment unit must adhere in order to legally treat PCB waste. An approval may be a test plan approval or an operating approval. This term is synonymous with “permit.”

### **Aroclor**

A commercial mixture of PCBs previously manufactured by Monsanto. Aroclor is one of the most commonly known trade names for PCB mixtures. There are many types of Aroclors and each has a distinguishing suffix number that indicates the degree of chlorination. The numbering standard for the different Aroclors is as follows: The first two digits are usually “12,” which represents a 1200 series product as designated by Monsanto. A 1200 series PCB product is a refined PCB product usually derived from the 1100 series crude PCBs. The second two numbers indicate the percentage of chlorine by mass in the mixture. For example, the name Aroclor 1254 means that the mixture contains approximately 54% chlorine by weight. See [Appendix G](#) for a complete list of Aroclors.

### **Combustion Efficiency (CE)**

A ratio of the actual combustion relative to complete combustion of a fuel.

$$CE = \left[ \frac{C_{CO_2}}{C_{CO_2} + C_{CO}} \right] \times 100$$

Where,

$C_{CO_2}$  = Concentration of carbon dioxide, and  $C_{CO}$  = Concentration of carbon monoxide.

### **Comparability**

A measure of the confidence with which one data set can be compared to another. This is a qualitative assessment and is addressed primarily in sampling design through the use of comparable sampling procedures or, for monitoring programs, through accurate re-sampling of stations over time. In the laboratory, comparability is assured through the use of comparable analytical procedures and ensuring that project staff are trained in the proper application of the procedures.

### **Completeness**

The amount of data collected as compared to the amount needed to ensure that the uncertainty or error is within acceptable limits. The goal for data completeness is 100%.

### **Congener**

For PCBs, any single, unique, well-defined chemical compound in the PCB category. The name of a congener specifies the total number of chlorine substituents, and the position of each chlorine. For example, 4,4'-dichlorobiphenyl is a congener comprising the biphenyl structure with two chlorine substituents, one on each of the #4 carbons of the two rings.

Altogether, there are 209 individual PCB congeners having the molecular formula  $C_{12}H_nCl_{10-n}$ , where  $n = 0-9$ . This definition includes monochlorobiphenyls. See [Appendix G](#) for a complete list of congeners.

### **Continuous Emissions Monitor (CEM)**

An emissions measurement system that is in continuous operation except for system breakdowns, repairs, calibration checks, and zero and span adjustments. See 40 CFR part 60, [Appendix C](#) for additional details.

### **Demonstration (Demo) Test**

A trial to evaluate the systems performance and compliance with applicable regulations, and to establish operating limits; commonly called a trial burn for incinerators. May be referred to simply as “test.” A complete demonstration test or trial burn typically requires three test runs. See [section 6](#) for more information.

## **Destruction and Removal Efficiency (DRE)**

EPA's principle measure of incinerator performance. A 99.9999 percent DRE means that one molecule of an organic compound is released to the air for every million molecules entering the incinerator. For PCBs, DRE is calculated using the following formula:

$$DRE = \left[ \frac{W_{in} - W_{out}}{W_{in}} \right] \times 100$$

Where,

$W_{in}$  = mass feed rate of PCBs in the waste stream feeding the incinerator, and

$W_{out}$  = mass emission rate of PCBs present in exhaust emissions prior to release to the atmosphere.

## **Disposal**

See definition in [40 CFR 761.3](#).

## **Dioxin**

This is the abbreviated or short name for a family of substances that all share a similar chemical structure; tetra-, penta-, hexa-, hepta-, and octa-chlorinated dibenzo dioxins. During certain PCB treatment/disposal processes it is possible to form dioxin byproducts.

## **Facility**

See definition in [40 CFR 761.3](#).

## **Furan**

This is the abbreviated or short name for a family of substances that all share a similar chemical structure; tetra-, penta-, hexa-, hepta-, and octa-chlorinated dibenzo furans. During certain PCB treatment/disposal processes it is possible to form furan byproducts.

## **Gas Residence Time**

The time that combustion gas spends in the destruction zone (area of combustion chamber with the temperature equal to or above that required by the regulations); calculated by dividing the destruction zone volume by the volumetric flow rate at the exit (actual pressure and temperature conditions).

## **High Resolution Gas Chromatography**

Gas-liquid chromatography performed using a capillary column, typically 10-50 meters (m) long x 0.2 millimeter (mm) inner diameter (ID), coated on the interior with a liquid phase.

## **Homolog**

Subcategories of PCB congeners that have equal numbers of chlorine substituents. For example, the tetrachlorobiphenyls are all PCB congeners with exactly 4 chlorine substituents that can be in any arrangement. Altogether, there are 10 homologs. See [Appendix G](#) for completed list of homologs.

## **Isomer**

Any compound that has the same molecular formula, but different positional substitutions. For example, for PCBs, 2,2'-dichlorobiphenyl and 2,3-dichlorobiphenyl are isomeric; 4-chlorobiphenyl and 2,3,4-trichlorobiphenyl are not.

**Liquid**

A substance that has a melting point less than 20°C and does not pass the structural integrity test (> 15% free liquid content).

**Liquid PCBs**

See definition in [40 CFR 761.3](#).

**Mass Spectrometry (MS)**

An analytical technique that ionizes chemical species and sorts the ions based on their mass-to-charge ratio. In simpler terms, a mass spectrum measures the masses within a sample.

**Matrix(ces)**

The component, or components, of a sample other than the analyte of interest. For example, this includes but is not limited to non-PCB components of dielectric fluid, soil, or sludge.

**Method**

A series of techniques or procedures that form a specific, well-defined sampling, chemical analysis, or other procedure for a specified compound(s)/matrix(ces) combination. See SW-846 for EPA developed test methods.

**Method 0010**

A method that outlines the emissions sampling procedure used to determine organic concentrations in stack emissions, including PCBs and Principal Organic Hazardous Constituents (POHCs). These emission levels can then be used to calculate Destruction and Removal Efficiency (DRE) of semi-volatile POHCs, including PCBs, from incineration systems.

**Method 23/0023A**

A method that outlines the procedure used for determining stack emissions of polychlorinated dibenzo-p-dioxins (PCDDs) and polychlorinated dibenzofurans (PCDFs) from stationary sources.

**Method 3540**

A method that outlines the procedure used for extracting nonvolatile and semi-volatile organic compounds from solids such as soils, sludges, and wastes. The Soxhlet extraction process ensures intimate contact of the sample matrix with extraction solvent.

**Method 3550C**

A method that outlines the procedure used for extracting nonvolatile and semi-volatile organic compounds from solids such as soils, sludges, and wastes. The ultrasonic process ensures intimate contact of the sample matrix with the extraction solvent.

**Method 8082A**

A method describing the procedure used to determine the concentrations of PCBs as Aroclors or as individual PCB congeners in extracts using open-tubular, capillary columns with electron capture detectors (ECDs) or electrolytic conductivity detectors (ELCDs). This method also includes extraction method recommendations for various sample matrices.

## National Emission Standards for Hazardous Air Pollutants (NESHAP)

National Emission Standards for Hazardous Air Pollutants (NESHAP) for stationary sources of hazardous air pollutants (HAP) are issued pursuant to Clean Air Act (CAA) Section 112(d). This provision requires EPA to promulgate regulations establishing emission standards for major sources and area sources of Hazardous Air Pollutants (HAPs) listed pursuant to CAA Section 112(c). EPA has identified hazardous waste combustors as major sources of HAP emissions and, consistent with the requirements of CAA Section 112(d), requires hazardous waste combustors to meet HAP emission standard reflecting the performance of the maximum available control technology (MACT). The NESHAP for Hazardous Waste Combustors are codified in 40 CFR Part 63 Subpart EEE.

## Non-liquid PCBs

See definition in [40 CFR 761.3](#).

## Normal Operations / Day-to-Day Operations

Everyday operations of a PCB treatment or disposal unit under specific conditions and processes as described in the facility's operating PCB approval. This would not include operating the unit to treat non-PCB-regulated waste or during the demonstration test or trial burn.

## Operator

The person responsible for the operation of a facility, part of a facility, a treatment unit, or the property the treatment unit stands upon.

## Owner

The person who owns a facility, part of a facility, a treatment unit, or the property the treatment unit stands upon.

## Packed Column Gas Chromatography (PGC)

Gas-liquid chromatography performed using a column, typically 180 centimeters (cm) long x 2 millimeters (mm) ID, packed with a liquid phase on a granular solid support material. Review the method being utilized for more detailed parameters required to conduct gas chromatography (GC).

## Parts Per Billion (ppb)

One part per 1,000,000,000 parts. Also see part per million (ppm).

## Parts Per Million (ppm)

One part per 1,000,000 parts. For gaseous mixtures, a volume/volume (v/v) basis is typically used and:

$$ppm = \frac{mg}{m^3} \times \frac{RT}{MW}$$

Where,

$RT$  (at 0°C and 1 atm) = 22.4 liter/g-mole,

$RT$  (at 25°C and 1 atm) = 24.5 liter/g-mole, and

$MW$  = molecular weight of compound, g/g-mole.

For low concentration aqueous samples, a weight/volume (w/v) basis is most commonly used, where

$1 ppm = 1 mg/L$ . A weight/weight (w/w) basis may also be used for aqueous samples, where

$1 ppm = 1 mg/kg$  (assuming a liquid density of 1 kg/L).



For nonaqueous liquids and solid materials, a weight/weight (w/w) basis is most commonly used, where  $1 \text{ ppm} = 1 \text{ mg/kg}$ .

### **PCB(s)**

See definition in [40 CFR 761.3](#).

### **PCB Item**

See definition in [40 CFR 761.3](#).

### **Percent Recovery**

The percent recovery is a measurement of accuracy, where one value is compared with a known/certified value. The formula for calculating this value is:

$$\text{Percent Recovery} = \frac{\text{amount detected}}{\text{amount expected}} \times 100$$

### **Performance Evaluation (PE) Sample**

PE samples, also known as proficiency testing (PT) samples, are samples of known concentration provided to the facility by EPA for analysis. The laboratory is required to analyze the PE samples according to the appropriate method and report the result of the PE sample analysis. These results are evaluated by EPA personnel for accuracy of analytical results based on known concentration in the PE sample. PE samples should be representative of the types of samples that would be routinely analyzed if an approval is granted to the facility.

### **Polychlorinated Biphenyl (PCB)**

See definition in [40 CFR 761.3](#).

### **Precision**

A measure of agreement among a set of observations or measurements of the same property, obtained under similar conditions. Precision is usually expressed as standard deviation, variance, relative percent difference, or range, in either absolute or relative terms. Precision is monitored through the analysis of QC samples.

### **Principal Manager**

The person responsible for the overall operation of a PCB treatment/disposal unit and typically the primary contact for EPA.

### **Quality Assurance (QA)**

A system for integrating the quality planning, quality assessment, and quality improvement efforts to meet user requirements.

### **Quality Assurance Project Plan (QAPP)**

A document that describes how quality assurance (QA) and quality control (QC) will be conducted and applied to assure that the results obtained are of the type and quality needed and expected.

**Quality Control (QC)**

The routine application of procedures for obtaining prescribed standards of performance in the monitoring and measurement process.

**QC Blank**

A sample processed and analyzed to obtain background concentrations of the analyte(s).

**Relative Percent Difference**

The relative percent difference (RPD) is a measurement of *precision*; it is a comparison of two similar samples (matrix spike/matrix spike duplicate pair, field sample duplicates). The formula for calculating RPD is:

$$RPD = \left| \frac{2 \times (X_1 - X_2)}{(X_1 + X_2)} \right| \times 100$$

where:  $X_1$  is concentration in sample 1  
 $X_2$  is concentration in sample 2

**Representative Sample**

A sample which, to the greatest extent possible, exhibits the average characteristics of the whole population.

**Representativeness**

The degree to which data accurately and precisely reflects the average characteristics of the whole population. This is a qualitative assessment and is addressed primarily in the sample design and procedures that reflect the project goals and processes being sampled. It is ensured in the laboratory through (1) the proper handling, homogenizing, compositing, and storage of samples and (2) analysis within the specified holding times so that the material analyzed reflects the material collected as accurately as possible.

**Residence Time**

The average amount of time spent in a control volume by the particles of a fluid. In the context of this document, for total residence time, the control volume is the PCB treatment train. For reactor residence time, the control volume is the reactor where PCB destruction takes place.

**Shakedown**

A pre-test or set of pre-tests designed and conducted to achieve a state of operational readiness necessary to conduct the trial burn or demonstration test. PCBs should not be introduced to the unit during the shakedown period.

**Solid**

A substance is a solid if its melting point is greater than 20°C and it passes the structural integrity test (> 15% free liquid content).

**SW-846**

See definition in [40 CFR 761.3](#).

## **Test**

This is a general term used to refer to a demonstration test, a trial burn or both. For example, statements that include “trial burn/demonstration test plan” or “trial burn/demonstration test approval” will be referred to as either “test plan” or “test approval.”

## **Test Run**

A full-scale run-through of a PCB treatment/destruction system where PCB waste is introduced to the unit and the unit processes the waste at conditions typically specified in a test approval until the PCBs are either destroyed or removed from the media. A test run demonstrates destruction or removal of PCBs from the media to an acceptable level in a single run-through. A complete demonstration test or trial burn typically requires three test runs. An incomplete test run may occur when unforeseen circumstances, e.g., a power outage, prevents the facility from completing that test run. This typically would invalidate the run, and likely result in the need to repeat the test run. A failed test run may occur when the facility is unable to achieve acceptable treatment levels in the media. See [section 6](#) for more information.

## **Toxic Equivalency (TEQ)**

This is the international method of expressing toxicity equivalence for dioxins and furans as defined in U.S. EPA, Interim Procedures for Estimating Risks Associated with Exposures to Mixtures of Chlorinated Dibenzo-p-dioxins and -dibenzofurans (CDDs and CDFs), 1989. See 40 CFR 63.1201.

## **Treatment**

*Treatment* is a subset of *disposal* as defined in [40 CFR 761.3](#). Specifically, treatment falls under the actions related to destroying, degrading, decontaminating, or confining PCBs and PCB Items.

## **Trial Burn**

A trial to evaluate an incinerator’s performance and compliance with applicable regulations, and to establish operating limits; commonly called a demonstration test for alternative destruction technologies. May be referred to simply as “test.” A complete demonstration test or trial burn typically requires three test runs. See [section 6](#) for more information.

## **TSCA Non-Thermal Destruction/Removal Technologies**

A device which does not use elevated temperatures as the primary means to reduce the concentration of or remove PCBs from PCB waste. These include, but are not limited to, mechanical-chemical destruction, catalytic hydrogenation, and chemical dechlorination. These processes are typically different from thermal destruction technologies. Also, there are a variety of types of non-thermal destruction technologies and they generally operate differently from each other.

## **TSCA Thermal Destruction Technologies**

A device which uses elevated temperatures as the primary means to reduce the concentration of or remove PCBs from PCB waste. These include, but are not limited to, incinerators, infrared incinerators, fluidized beds, fluidized circulating beds, scrap metal recovery ovens, high efficiency boilers, and thermal desorbers. Since most thermal technologies employ high temperature destruction of PCBs, these processes typically have similar requirements, such as air emissions monitoring.

# SECTION 1

## INTRODUCTION

Part 761 in Title 40 of the Code of Federal Regulations (40 CFR part 761) establishes rules on the manufacture, processing, distribution in commerce, use, disposal, storage, and marking of polychlorinated biphenyls (PCBs) and PCB Items.<sup>1</sup> Under these rules, persons (defined at [40 CFR 761.3](#)) disposing of regulated PCBs are required to use approved methods and, in some cases, obtain an approval.<sup>2</sup>

PCB wastes may be disposed of in incinerators that comply with § 761.70 or in facilities approved under § 761.60(e) as achieving a level of performance equivalent to an incinerator approved under § 761.70. Other disposal options are available for many types of PCB waste (e.g., landfills as specified in 40 CFR 761.75), but certain PCB wastes must be disposed of using one of those two options. Alternative disposal methods such as, but not limited to, thermal desorption and chemical dechlorination, reduction, or oxidation may be approved for use under § 761.60(e).

This document provides guidance for persons applying to the U.S. Environmental Protection Agency (EPA) for approval to dispose of PCBs using thermal and non-thermal alternative methods (§ 761.60(e)), and incineration (§ 761.70).<sup>3</sup> This document presents and discusses the format, content, and suggested level of detail for approval applications, trial burn and demonstration (demo) test plans, and trial burn and demo test reports. Note that each technology is unique and that some elements discussed in this guidance document may not be applicable to all technologies.

This guidance only addresses the approval process for the disposal of PCBs under the Toxic Substances Control Act (TSCA). Other federal laws such as the Resource Conservation and Recovery Act (RCRA), Clean Water Act (CWA), Clean Air Act (CAA), and Occupational Safety and Health Act (OSHA) as well as state and local laws may also regulate PCB disposal. Some states have a PCB program with state specific regulations that differ from federal regulation. Satisfying only state requirements does not ensure that a facility has met all federal requirements. Facilities should ensure that they comply with both state and federal requirements.

### 1.1 Benefits of this Guidance

This guidance benefits both applicants and EPA because it clarifies expectations and promotes consistency. The previous guidance documents for incineration (§ 761.70) and alternative methods (§ 761.60(e)) were originally developed in 1986 and decades have passed without any published

---

<sup>1</sup> U.S. Environmental Protection Agency, 1979. “Polychlorinated Biphenyls (PCBs) Manufacturing, Processing, Distribution in Commerce, and Use Prohibitions,” Federal Register, Volume 44, pp. 31514-31568, May 31, 1979.

<sup>2</sup> “Disposal” means intentionally or accidentally to discard, throw away, or otherwise complete or terminate the useful life of PCBs and PCB Items. Disposal includes spills, leaks, and other uncontrolled discharges of PCBs as well as actions related to containing, transporting, destroying, degrading, decontaminating, or confining PCBs and PCB Items ([40 CFR 761.3](#)).

<sup>3</sup> For this document “disposal” includes certain processing activities, as indicated in § 761.20(c)(2)(ii). Under the TSCA regulations, processing activities associated with and facilitating treatment (as defined in 40 CFR 260.10) require a TSCA PCB disposal approval unless they are part of an existing approval or self-implementing activity or are otherwise specifically allowed under the PCB disposal regulations (40 CFR part 761, subpart D), such as through a decontamination activity covered under § 761.70(b) or (c) [see § 761.20(c)(2)(ii)].

updates.<sup>4</sup> As a result, applicants sometimes submit incomplete applications, thus delaying the approval process. The new guidance document combines information from the 1986 guidance documents with current standard practices, policy, and regulation changes that have occurred since 1986. No new requirements or interpretations were created in this guidance. EPA believes that incorporating both 1986 guidance documents and current standard practices into one document will reduce the back-and-forth between the applicant and EPA and reduce the overall time spent on an application.

A few of the benefits of this guidance are:

- Higher quality applications which will reduce revisions to address deficiencies during EPA review;
- A reduction of the overall time to obtain an operating approval;
- An increase in transparency and expectations by incorporating regulatory changes, guidance documents, and policy decisions since 1986;
  - Topics incorporated into this updated guidance include: financial assurance, safety requirements, and Quality Assurance Project Plans (QAPP); and
- Easy-to-use, modern format of the guidance (e.g., the document is now word searchable).

## 1.2 Organization and How to Use

This guidance document is organized such that it walks the applicant through each stage of the approval process. First, a general overview is provided giving the applicant an understanding of EPA procedures, relevant regulations and the steps involved in the approval process ([Sections 2](#) and [3](#)). Detailed guidance is then given regarding preparation and submission of approval applications and test plans ([Sections 4](#) and [5](#)). [Section 6](#) discusses how tests are conducted and, after a completed test, [Section 7](#) helps the applicant prepare and submit a test report. [Section 8](#) discusses the final operating approval and how to modify or renew an existing approval. Lastly, a significant amount of supplemental information is provided in the [appendices](#) to help the applicant through various steps of the approval process.

We recommend applicants initially review this entire guidance and then focus on specific sections as they move through the application process. For example, when an applicant completes their demonstration test, they would use section 7 as an aid to develop their test report. Each section was developed with the appropriate information such that individual sections can be read without having to frequently reference other sections of the guidance, but as a result, some information may appear to be repetitive between multiple sections.

Some discussions in this guidance are separated into thermal and non-thermal sections to help guide the reader toward the requirements and suggestions that would apply to their technology. Thermal destruction technologies generally use high heat (> 500°C) and require air emissions monitoring; this typically includes incineration, desorption with an afterburner, or vitrification. Non-thermal destruction/removal technologies destroy/remove PCBs, typically in the absence of high temperatures, and do not require air emissions monitoring. Non-thermal destruction/removal technologies may include oxidation, catalytic hydrogenation, solvated electron technology, chemical dechlorination processes (i.e., sodium emulsion), or mechanochemical destruction. Applicants should remember that their technology may not fall exclusively into one category. For example, thermal desorption with a condenser or carbon

---

<sup>4</sup> The 1986 guidance documents are “[Draft Guidelines for Permit Applications and Demonstration Test Plans for PCB Incinerators](#),” and “[Draft Guidelines for Permit Applications and Demonstration Test Plans for PCB Disposal by Non-Thermal Alternative Methods](#).”

filter will use slightly elevated temperatures (relative to an incinerator) to remove PCBs from a medium but the PCBs are generally not destroyed in the process. In this example, air emissions monitoring will likely be needed for EPA to determine whether the level of performance is equivalent to an incinerator approved under § 761.70 and this technology does not present an unreasonable risk of injury to health or the environment. However, many of the operating conditions may be different from an incinerator and reviewing only the thermal sections of this guidance may not provide comprehensive guidance. If this is the case, then it is recommended that applicants review both thermal and non-thermal sections of this guidance.

Note that when reading this document, “test” is a general term used to refer to a demonstration test, a trial burn or both. For example, statements that include “trial burn/demonstration test plan” or “trial burn/demonstration test approval” will be referred to as either “test plan” or “test approval.”

## SECTION 2

# SUMMARY OF RELEVANT 40 CFR PART 761 REGULATIONS

This document is intended to provide guidance for obtaining EPA approval for PCB disposal by non-thermal alternative methods (§ 761.60(e)), thermal alternative methods (§ 761.60(e)), and incineration (§ 761.70).<sup>5</sup> This section summarizes pertinent provisions of 40 CFR part 761 related to the disposal of PCBs. Part 761 establishes requirements for the manufacture, processing, distribution in commerce, use, disposal, storage, and marking of PCBs.

### 2.1 General

The storage and disposal of PCBs are addressed in subpart D of 40 CFR 761. In § 761.60 of subpart D, disposal requirements are generally differentiated according to waste type and PCB concentration. See [40 CFR part 761](#) for PCB disposal options and requirements. In [Appendix A](#), Table A-1 presents an outline of the sections of 40 CFR part 761 relevant to this guidance document.

This guidance document only addresses incineration and alternative to incineration PCB approvals, which are issued under §§ 761.60(e) and 761.70. This document does not address disposal, cleanup, or decontamination methods that are allowable without an approval as long as regulatory standards are met, or allowable with an approval other than those issued under §§ 761.60(e) and 761.70. However, in some scenarios, an incinerator or alternative to incineration PCB approval (§§ 761.60(e) or 761.70) may be issued along with a second type of approval not discussed in this guidance document, typically a commercial storage approval (§ 761.65). The applicant should be aware that, while this guidance does not discuss the requirements for a commercial storage approval or other types of approvals, a second approval may be necessary depending on the treatment technology and should be discussed with the approval writer. Furthermore, depending on where the technology will be operated and if a second approval is deemed necessary, it may require coordination between multiple EPA Regions and/or EPA Headquarters (HQ).

**MORE THAN ONE TYPE  
OF APPROVAL MAY BE  
NECESSARY DEPENDING  
ON THE TREATMENT  
TECHNOLOGY**

### 2.2 Approval Authority

The EPA officials with authority to approve PCB disposal methods are stated in § 761.60(e) and (i) and 761.70(a) and (b). The EPA officials granted primary approval authority for PCB disposal activities under § 761.60(e) and 70 are the Director of the Office of Resource Conservation and Recovery (ORCR) and the EPA Regional Administrators. Generally, requests for approval of technologies/methods to be used in more than one EPA Region should be submitted to the Director of ORCR and requests for approval of methods used in only one EPA Region should be submitted to the Regional Administrator. Table 1 summarizes the EPA officials with approval authority for relevant PCB disposal facilities. Addresses and contact information for EPA Headquarters and the 10 EPA Regional offices are available at <https://www.epa.gov/pcbs/program-contacts>.

---

<sup>5</sup> If the treated waste will be sent to a landfill or for further treatment elsewhere, then a different type of approval will likely be required. Contact EPA for more information.

**Table 1. Summary of Relevant Approval Authorities**

<b>Disposal Method Description</b>	<b>Approval Authority<sup>1</sup></b>
Mobile alternative treatment or site-specific stationary alternative treatment of identical design to be used in more than one EPA Region	Director of ORCR (§ 761.60(e))
Mobile alternative treatment or site-specific stationary alternative treatment of identical design to be used in a single EPA Region	EPA Regional Administrators (§ 761.60(e))
Mobile incinerators or site-specific stationary incinerators of identical design to be used in more than one EPA Region	Director of ORCR (§ 761.70(a), (b))
Mobile incinerators or site-specific stationary incinerators of identical design to be used in a single EPA Region	EPA Regional Administrators (§ 761.70(a), (b))
Research and development methods of identical design to be used in more than one EPA Region involving < 500 pounds of PCB material, including activities involving < 500 pounds of PCB material authorized under § 761.60(j), except for self-implementing activities authorized under § 761.60(j)	Director of ORCR (§ 761.60(i))
Research and development methods of identical design to be used within a single EPA Region involving < 500 pounds of PCB material, including activities involving < 500 pounds of PCB material authorized under § 761.60(j), except for self-implementing activities authorized under § 761.60(j)	EPA Regional Administrators (§ 761.60(i))
Research and development methods of identical design involving ≥ 500 pounds of PCB material, including activities involving ≥ 500 pounds of PCB material authorized under § 761.60(j), except for self-implementing activities authorized under § 761.60(j)	Director of ORCR (§ 761.60(i))

<sup>1</sup> Note that the delegated approval authority may change or, in some instances, be delegated to the appropriate division director. Also, the authority to review and approve any aspect of the disposal system may be allocated to the Office of Land and Emergency Management (OLEM) Administrator or to a Regional Administrator. It is recommended that prospective applicants contact the appropriate EPA Region or Headquarters for more information when determining where to submit an application.



## 2.3 Incinerators

Section 761.70 provides performance standards for PCB incinerators. To be approved, incinerators must meet specific requirements (unless EPA waives a requirement in accordance with § 761.70(d)(5)), and must not present an unreasonable risk of injury to health or the environment. Incinerator requirements, including operating parameters, for destruction of liquid and non-liquid PCBs are provided in § 761.70(a) and § 761.70(b), respectively. Section 761.70(c) establishes requirements for maintaining records and § 761.70(d) establishes requirements for obtaining approval of incinerators. Each of these provisions is discussed in the following subsections. Pursuant to § 761.70(d)(4)(ii), additional operating parameters may be included as conditions of the operating approval based on the operating parameters that are observed during any demonstration test. See Table B-3 in [Appendix B](#) for a list of such parameters.

### 2.3.1 Liquid PCBs

Section 761.70(a) establishes the minimum requirements for the destruction of liquid PCBs by incineration. These requirements include the following:

- The introduced liquid shall be maintained for a 2-second dwell time at 1200 degrees Celsius (°C) ( $\pm 100^\circ\text{C}$ ) and 3 percent excess oxygen ( $\text{O}_2$ ) or a 1.5-second dwell time at 1600°C ( $\pm 100^\circ\text{C}$ ) and 2 percent excess  $\text{O}_2$  in the stack gas;
- Combustion efficiency (CE) shall be at least 99.9 percent computed as follows:

$$CE = \left[ \frac{C_{CO_2}}{C_{CO_2} + C_{CO}} \right] \times 100$$

Where,

$C_{CO_2}$  = Concentration of carbon dioxide,  $C_{CO}$  = Concentration of carbon monoxide

- The rate and quantity of PCBs which are fed to the combustion system shall be measured and recorded at regular intervals of no longer than 15 minutes;
- The temperatures of the incineration process shall be continuously measured and recorded. The combustion temperature of the incineration process shall be based on either direct (pyrometer) or indirect (wall thermocouple-pyrometer correlation) temperature readings;
- The flow of PCBs to the incinerator shall stop automatically whenever the temperature drops below the minimum levels required to be maintained for the introduced liquid, specified above;
- Stack emission products shall be monitored for  $\text{O}_2$ , CO,  $\text{CO}_2$ ,  $\text{NO}_x$ , HCl, total chlorinated organic content (RCI), PCBs, and total particulate matter, at a minimum, when:
  - An incinerator is first used for PCB disposal under § 761.70, and
  - An incinerator is first used for PCB disposal after the incinerator has been modified in a manner which may affect the characteristics of the stack emission products;
- Monitoring and recording of combustion products and incineration operations shall be conducted for  $\text{O}_2$  (continuously), CO (continuously), and  $\text{CO}_2$  (periodically at a frequency specified by the Director of ORCR, Regional Administrator, or delegated official), at a minimum, whenever PCBs are being fed to the incinerator;
- The flow of PCBs to the incinerator shall automatically stop whenever there is a failure of the monitoring operations for  $\text{O}_2$ , CO,  $\text{CO}_2$ ; a failure of the PCB rate and quantity measuring and recording equipment; or the excess  $\text{O}_2$  falls below the minimum levels required to be maintained for the introduced liquid, unless a contingency plan indicating alternative measures the incinerator owner/operator would take during such conditions is submitted by the owner/operator

and approved by the EPA Regional Administrator, Director of ORCR, or delegated official; and

- Water scrubbers or an EPA-approved alternative method shall be used for HCl control during PCB incineration and shall meet any performance requirements specified by EPA. The scrubber effluent shall be monitored and shall comply with any applicable effluent or pretreatment standard and any other state and federal laws and regulations.

EPA also generally assesses performance of the following criteria to assure adequate destruction of PCB liquids that is necessary to find no unreasonable risk when reviewing incinerator approval applications:

- Mass air emissions from the incinerator of no greater than 0.001 g PCB/kg of the PCB introduced to obtain a destruction and removal efficiency (DRE) of at least 99.9999% (commonly referred to as “six nines”);
- Measurement of the stack emissions for chlorinated dibenzodioxins and dibenzofurans;<sup>6</sup>
- Particulate matter emission levels of less than or equal to 0.015 grains (gr) per dry standard cubic foot (dscf) when corrected to 7 percent O<sub>2</sub>;
- An hourly rolling average of no greater than 100 ppm CO or an hourly rolling average of no greater than 10 ppm hydrocarbons; and
- PCB concentrations in fly ash (if applicable) and bottom ash (if applicable) of less than or equal to 2 parts per million (ppm) and in scrubber water of less than or equal to 0.5 microgram (µg) per liter (l) for unrestricted use (approximately  $\leq 0.5$  parts per billion [ppb]).

### 2.3.2 Non-liquid PCBs

Section 761.70(b) describes requirements, similar to those for liquid PCBs, for the destruction of non-liquid PCBs, PCB Articles, PCB Equipment, and PCB Containers by incineration (see § 761.3 for definitions). § 761.70(b) requires compliance with § 761.70(a) requirements for the destruction of liquid PCBs by incineration, except: 1) § 761.70(a)(1) combustion criteria do not apply; 2) § 761.70(b) also requires the mass air emissions from the incinerator to be no greater than 0.001 g PCB for every kg of PCB introduced into the incinerator, i.e., the incinerator must achieve a DRE of at least 99.9999%; and 3) the flow of PCBs to the incinerator does not have to automatically stop when the combustion temperature drops below temperatures specified in § 761.70(a)(1) or when excess oxygen falls below the percentage specified in § 761.70(a)(1). Regardless, some of these exceptions may be included by the approval writer to ensure no unreasonable risk of injury to health or the environment for certain sites or situations.

Destruction of non-liquid PCBs, PCB Articles, PCB Equipment, or PCB Containers should meet the following criteria:

- Measurement of the stack emissions for chlorinated dibenzodioxins and dibenzofurans;<sup>7</sup>
- Particulate matter emission levels of less than or equal to 0.015 gr/dscf when corrected to 7 percent O<sub>2</sub>;
- An hourly rolling average of no greater than 100 ppm CO or an hourly rolling average of no greater than 10 ppm hydrocarbons; and

---

<sup>6</sup> Dioxins/furans released in a stack should be < 0.2 ng TEQ/dscm for new sources and < 0.4 ng TEQ/dscm for existing sources as specified 40 CFR 63.1219. However, the standards listed for dioxin and furans may differ than what is stated here based on the treatment and air pollution control devices used. See 40 CFR part 63 for more information.

<sup>7</sup> See previous footnote.

- PCB concentrations in fly ash (if applicable) and bottom ash (if applicable) of less than or equal to 2 ppm and in scrubber water for unrestricted use of less than or equal to 0.5 µg/L (approximately ≤ 0.5 ppb).

### ***2.3.3 Maintenance of Data and Records***

Section 761.70(c) establishes requirements for maintenance of data and records for PCB incinerators. Records shall be maintained according to the provisions established in § 761.180. The required records and associated retention times are discussed in more detail in [section 4.2.10](#) of this document.

### ***2.3.4 Approval of Incinerators***

Section 761.70(d) establishes requirements for an owner or operator to obtain written approval from the EPA officials with authority to approve incineration of PCBs and PCB Items. These requirements include submitting the following documents to the appropriate EPA Headquarters or Regional office: 1) an application for an operating approval; and 2) a trial burn<sup>8</sup> plan, if EPA determines that a trial burn is required following receipt of the operating approval application.

While § 761.70(d)(2) says that EPA will determine if a trial burn is required following receipt of the application for an operating approval, EPA generally requires a trial burn for all incinerator approvals issued under § 761.70 to support a no unreasonable risk determination.<sup>9</sup> Also, applicants may submit their trial burn plan after, with, or before their application but both the application and trial burn plan are typically required prior to EPA issuing approval to conduct the trial burn. If the applicant does not wish to conduct a trial burn then EPA recommends that they discuss this with their approval writer (see [section 3.1](#)). EPA generally asks owners/operators to submit trial burn reports describing the results of trial burns pursuant to § 761.70(d)(3), which enables EPA to “require the owner or operator to submit any other information that the EPA finds to be reasonably necessary to determine whether an incinerator shall be approved.”

The contents of an approval application, a test plan, and test report are presented and discussed in detail in [sections 4](#), [5](#) and [7](#) of this document, respectively. Section 761.70(d) also provides procedures for obtaining waivers from requirements in § 761.70(a) and (b) and for transferring ownership of an approved incinerator, neither of which are discussed in this guidance document.

## **2.4 Alternative Methods of Disposal**

Under § 761.60(e), “any person who is required to incinerate any PCBs and PCB Items under this subpart and who can demonstrate that an alternative method of destroying PCBs and PCB Items exists and that this alternative method can achieve a level of performance equivalent to an incinerator approved under § 761.70 or a high efficiency boiler operating in compliance with § 761.71 shall submit a written request to the Regional Administrator or the Director of the Office of Resource Conservation and Recovery, for a waiver from the incineration requirements of § 761.70 or § 761.71.”

The request shall be sent to either the Regional Administrator or Director of ORCR in accordance with

---

<sup>8</sup> Note that throughout the rest of the guidance “trial burn” is generally referred to as “test” (see discussion in [section 1.2](#)). EPA uses the term “trial burn” in this section for clarity and consistency with the PCB regulations.

<sup>9</sup> According to § 761.70(d)(4)(ii), EPA “may include in an approval any other requirements that EPA finds are necessary to ensure that operation of the incinerator does not present an unreasonable risk of injury to health or the environment from PCBs.”

§§ 761.60(e) and (i). The applicant using a thermal or non-thermal alternative method of disposal must demonstrate 1) that the method can achieve a level of performance equivalent to an incinerator approved under § 761.70 or, for liquid PCB wastes between 50-500 ppm, a high efficiency boiler operating in compliance with § 761.71 and 2) that the method will not present an unreasonable risk of injury to health or the environment. These two requirements should be taken into consideration by the applicant and should be appropriately addressed in the approval application and proven during the test. EPA typically requires a test to be conducted for all alternative technologies to determine there is no unreasonable risk of injury to health or the environment.

#### ***2.4.1 Alternative Thermal Destruction Technologies***

Approvals for alternative thermal technologies typically have similar operating requirements as approvals for incinerators because the measurements of performance are similar. Generally, stack emissions must demonstrate a DRE of PCBs of at least 99.9999 %, combustion efficiency and oxygen requirements may apply, and ash, like all other solid process wastes, must contain less than or equal to 2 ppm PCBs (the detection limit) to be unregulated for disposal. Many other conditions may apply depending on the technology and characteristics of the waste. Any aspect of the process that may pose risks of injury to health or environment should also be addressed in the approval application.

#### ***2.4.2 Alternative Non-Thermal Destruction/Removal Technologies***

Alternative non-thermal methods of PCB destruction/removal often differ significantly from incineration and other thermal treatment processes. For alternative processes that non-thermally destroy/remove PCBs, EPA generally asks the applicant to show that the concentration of PCBs is no more than 2 ppm in the product or the process waste. Any aspect of the process that may pose risks of injury to health or environment should be addressed in the approval application. Examples of such risks include emissions of toxic solvents to the atmosphere and explosion/fire hazards from sodium exposure to moisture or hydrogen release.

### **2.5 Other Regulations**

Applicants should also take into consideration other regulations that may be applicable to their process. For example, states may have more stringent requirements, additional air regulations may apply, water regulations may apply if there is discharge into a body of water, and treatment of radioactive wastes may require input from the Nuclear Regulatory Commission (NRC) and others. It is the responsibility of the applicant to have all the proper permits and approvals prior to operating their treatment or disposal process.

Furthermore, although an operating approval may reference additional requirements of 40 CFR part 761, the approval should not be relied upon for all requirements related to PCBs or the disposal of PCB waste. If the information contained in the approval application or other supporting documents submitted to EPA differs from the conditions specified in the approval, the conditions of the operating approval shall govern.

#### ***2.5.1 High Efficiency Boilers***

High efficiency boilers may be used to burn MODEF (mineral oil dielectric fluid) and other liquids containing a PCB concentration of  $\geq 50$  ppm, but  $< 500$  ppm. Any person using a high efficiency boiler to dispose of such PCB liquids must use a boiler that meets the criteria set forth in § 761.71. The criteria differ depending on the material being burned.

Note that when burning liquids other than MODEF with concentrations of  $\geq 50$  ppm but  $< 500$  ppm PCBs, approval must be obtained from the EPA Region in which the boiler is located, as required in § 761.71(b).

### ***2.5.2 Scrap Metal Recovery Ovens and Smelters***

Any person may dispose of residual PCBs associated with PCB-Contaminated articles regulated for disposal under § 761.60(b), metal surfaces in PCB remediation waste regulated under § 761.61, or metal surfaces in PCB bulk product waste regulated under §§ 761.62(a)(6) and 761.79(c)(6), from which all free-flowing liquids have been removed, in a scrap metal recovery oven or smelter that meets the criteria set forth in § 761.72.

Note that scrap metal recovery ovens and smelters must either have a final permit under RCRA (40 CFR part 266, subpart H and 40 CFR 270.66) or be operating under a valid state air emissions permit which includes a standard for PCBs. Alternatively, the EPA official with approval authority for the EPA Region in which the oven or smelter is located, may make a finding (based on a site-specific risk assessment) that the oven or smelter does not pose an unreasonable risk of injury to health or the environment.

## SECTION 3

# BASIC APPROVAL PROCEDURES FOR THE TREATMENT/DISPOSAL OF PCBs USING INCINERATION OR AN ALTERNATIVE TECHNOLOGY

This section provides an overview of the steps toward obtaining an approval to treat/dispose of PCBs using incineration or an alternative method. Figure 1 shows the major steps in the operating approval process.

### 3.1 Establishing Communications with the EPA Approval Writer

For all approvals covered under this guidance document, the applicant should proactively establish early communications with the appropriate EPA approval writer. This will shift critical discussions to the beginning of the process, so that EPA and the applicant can reach an agreement on critical issues and expectations as early as possible. The applicant and EPA approval writer can discuss any special circumstances, each party's expectations, and procedures for the submission of information. EPA may be able to provide early feedback indicating important considerations, such as public participation or additional sampling/monitoring requirements. Additionally, EPA will gain a better understanding of the goals and constraints of the applicant and their treatment process. Advance notice of submissions will allow the EPA approval writer to schedule the review so that it can be completed in a timely fashion. Furthermore, early and routine communication throughout the application process should minimize EPA requests for additional information, reduce the amount of superfluous information submitted by the facility, and speed up the approval issuance process overall.

### 3.2 Research and Development

A facility seeking to use an uncommon or novel alternative disposal method should consider doing Research and Development (R&D). While R&D may not be a required step in obtaining an operating approval, it may assist in transitioning the treatment/disposal process from conception to commercial operation. Additionally, information from R&D studies can provide a proof of concept for novel or uncommon technologies that do not have established operating parameters for treating PCB waste. If the facility determines that R&D is not needed then they may skip this step. However, it is important to communicate this to EPA prior to developing the operating approval application.

An approval application for R&D activities that are not self-implementing activities (see discussion in section 4.1.4) should follow the same format as an operating approval application (see [section 4.2](#) for the format of an operating approval application). The application also should supply information on the specific objectives of the R&D activity. Due to the limited scope and duration of R&D activities, technical details, monitoring and sampling plans, health and safety plans, etc., do not need to be as extensive as those provided for long-term, full-scale operating approvals. Although the R&D approval application may not have the level of detail of an operating approval application, it should be sufficient to demonstrate that the R&D activity will not present an unreasonable risk of injury to health or the environment.

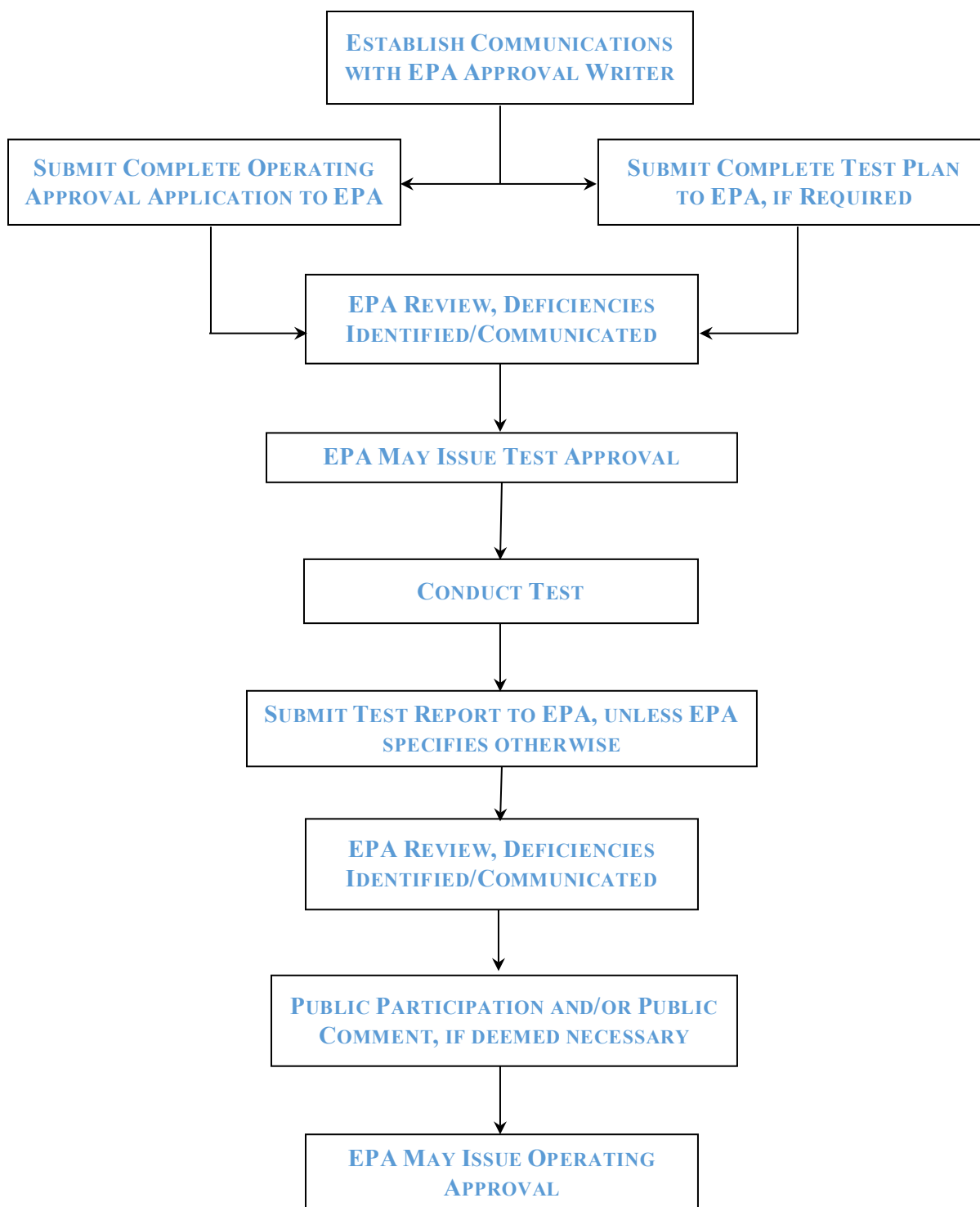

**Figure 1. Major Steps in the Operating Approval Process**

### 3.3 Submittal of Operating Approval Application and Test Plan

Paragraph § 761.70(d)(1) establishes the information that must be included in an approval application to operate a PCB incinerator. EPA suggests that the same information be included in an approval application to operate PCB disposal technologies that are alternatives to an incinerator pursuant to § 761.60(e), as such information is generally needed for EPA to find that the alternative method can achieve a level of performance equivalent to disposal in a § 761.70 incinerator or a § 761.71 high efficiency boiler and will not present an unreasonable risk of injury to health or the environment, as required under § 761.60(e). [Section 4](#) of this document presents EPA's suggested content and format for an application for an operating approval pursuant to § 761.60(e). Table B-1 in [Appendix B](#) provides a checklist to aid the applicant in determining if all requirements and recommendations for an application have been addressed.

**THE APPLICANT SHOULD GIVE CAREFUL CONSIDERATION TO THE DESIGN AND CONDUCT OF THE TEST. THE CONDITIONS CHOSEN FOR THE TEST GENERALLY INFORM THE SELECTION OF REQUIREMENTS IN THE OPERATING APPROVAL.**

As discussed in [section 1.2](#), a trial burn or demonstration test, is generally referred to as a test. A test is typically required prior to issuance of approvals for incinerators or alternative technologies. A test plan is a document prepared specifically for the test, and provides details of how the test will be conducted. [Section 5](#) of this document presents the information that is typically needed to prepare a complete test plan. Table B-2 in [Appendix B](#) provides a checklist to aid the applicant in determining if these items have been addressed in the test plan. Operating approval requirements usually reflect the system's operating conditions during the test. Therefore, the applicant should give careful consideration to the design and conduct of the test. For more information, see discussion in [section 5.1.1](#) regarding the purpose of the test.

The applicant should submit both an operating approval application and a test plan to receive a test approval. The operating approval application and test plan should be separate, complete documents. The operating approval application should be submitted as early as possible. In special circumstances, partial submissions are acceptable if the submission clearly indicates the portions of the application to be submitted later, and if the applicant and EPA approval writer agree that a preliminary review of a partial submission will be productive. The test plan may be submitted before, with, or after the operating approval application. However, a test cannot be conducted before a complete application and test plan are submitted and approved by EPA. While electronic submission of files is preferred, EPA will occasionally request paper copies.

**THE TEST PLAN MAY BE SUBMITTED BEFORE THE APPROVAL APPLICATION.**

Special consideration should be given to figures included in the application and test plan such that, as feasible, they are prepared in a manner that is useable and readable by color-blind people (i.e., figures should be readable in black and white). Symbols with different shapes and/or shading may be used.

### 3.4 EPA Review of Operating Approval Application and Test Plan

EPA reviews the operating approval application and test plan for completeness, accuracy, clarity, and technical viability. If either document is unacceptable, EPA will notify the applicant of any deficiencies, and request submittal of additional information, or data, as needed. The deficiencies should be corrected



in a revised application or test plan, and the revised document(s) should be submitted to EPA. In some cases, this process may need to be repeated more than once. EPA may deny the application if the deficiencies are not addressed within a reasonable period of time.

### 3.5 EPA Approval of Test Plan

After EPA confirms that the operating approval application and test plan are complete, accurate, clear, and technically viable, EPA will issue a test plan approval. A test plan approval is required prior to destroying any PCBs in the unit. The test plan approval will specify a limited amount of PCB-containing material that can be destroyed during the test and other conditions based on the applicant's operating approval application and test plan. The time period for which the test plan approval is valid normally ranges from one to four months. There may need to be public notice of the test plan, and timing of the test should take this into account.

### 3.6 Conducting a Test

A test is scheduled at a date and time agreeable to both the applicant and EPA. It is desirable that EPA have at least 60 days notice prior to the test. The relevant state and local government authorities must be notified at least 30 days prior to conducting the test.<sup>10</sup> Public notice may be required in advance of the test; review your test approval or ask your approval writer for specific public notice requirements.

If any modifications to the test plan are needed prior to the test, the applicant is requested to notify the EPA approval writer in writing at least 14 days prior to the test. See [section 5](#) for more information.

The test should be conducted under conditions simulating the most challenging scenarios expected to be encountered under commercial operations (e.g., highest PCB concentrations expected, highest degree of chlorination, hardest matrix condition to treat, highest porosity, or most organic matter). [Section 6](#) of this document provides more details on conducting a test.

### 3.7 Submittal of Test Report

After a test has been performed, EPA generally asks that a report documenting the test results be prepared and submitted. As noted above, reports for incinerators are generally sought under the authority of § 761.70(d)(3). For alternative treatment methods conducted under § 761.60(e), test reports are sought to evaluate if the level of performance is equivalent to disposal in a § 761.70 incinerator or a § 761.71 high efficiency boiler and will not present an unreasonable risk of injury to health or the environment, as required under § 761.60(e). A test report should be submitted to EPA regardless of whether the technology passes or fails the test. [Section 7](#) of this document provides the format and contents of the report.

### 3.8 EPA Review of the Test Report

Upon receipt of a test report, EPA will conduct a review of the report. If the test report is incomplete or unclear, EPA will notify the applicant that the report is deficient and may request submittal of additional information or data as needed.<sup>11</sup>

---

<sup>10</sup> 40 CFR 761.60(f).

<sup>11</sup> EPA may deny the application if the deficiencies are not addressed within a reasonable period of time.

After review of the test report, EPA may:

- Move forward with drafting an operating approval;
- Deny the operating approval without further consideration;
- Recommend that the applicant submit a R&D approval application in order to provide an opportunity to correct operating deficiencies prior to another test;
- Reschedule the test with the same test plan, which is usually done when minor deficiencies in the operating process cause the problem. The applicant would be requested to provide adequate assurance to the approval writer that deficiencies have been corrected and subsequent test failure is unlikely, that the test would be conducted in a manner that will not present an unreasonable risk of injury to health or the environment, and that no modifications are needed to the treatment system to assure it will be in full compliance with the performance standards; or
- Reschedule the test with a new test plan, which is usually used when major design changes must be made or major operating deficiencies must be corrected before another test can be performed. In such circumstances the facility should submit a revised test plan that reflects design or operational changes such that there is adequate assurance the treatment unit will achieve relevant performance standards. EPA will issue another test plan approval, if warranted.

### **3.9 EPA Issues an Operating Approval**

After receipt of the complete operating approval application and of the test results, EPA may issue a final operating approval that allows the owner/operator to operate the PCB treatment unit(s) in accordance with the terms and conditions in their approval. At a minimum, the final operating approval will specify the type of PCB-containing material that can be processed, an upper limit on PCB concentration in the feed, and an effective period, usually 5 to 10 years from the date of issuance.

Prior to renewal of an operating approval, additional information/testing and/or re-testing of the process is generally required. The operating approval will typically specify when the facility owner/operator should submit an operating renewal application if it wishes to continue treating PCB waste after the expiration date of the approval, and describe the steps to continue the effectiveness of an operating approval pending EPA action on reissuance.<sup>12</sup> EPA will determine if a re-test is required and, if so, then the applicant will be asked to develop a test plan.

---

<sup>12</sup> EPA typically requires a renewal application to be submitted 6 months in advance of the expiration date of the current approval. See [Section 8](#) of this document for more details.

## SECTION 4

# CONTENTS OF AN OPERATING APPROVAL APPLICATION

This section describes the information that should be included in operating approval applications for PCB treatment/disposal activities utilizing incineration or alternative technologies.<sup>13</sup> The minimum required contents of an operating approval application are covered under 40 CFR 761.70(d)(1) for PCB incinerators, and 40 CFR 761.60(e) for alternative technologies. The application should be submitted to the same delegated EPA official as the test plan (see [section 2.2](#) for a more detailed discussion on EPA delegation of authority). While electronic submission of files is preferred, EPA will occasionally request paper copies.

### 4.1 Preliminary Steps to an Approval Application

The subsections below discuss various requirements and suggestions for the applicant to keep in mind prior to and during the development of their operating approval application.

#### 4.1.1 Early Communication

Early communication and a face-to-face meeting with EPA are highly recommended before the applicant begins developing their application, since it is beneficial to both EPA and the applicant. This will shift critical discussions to the front of the process, so that EPA and the applicant communicate and reach an agreement as early as possible. EPA may be able to provide early feedback indicating potential considerations, such as public participation and/or additional sampling/monitoring requirements, should the applicant move forward with the operating approval application. Additionally, EPA will gain a better understanding of the goals and constraints of the applicant and their treatment process. Following the initial meeting between EPA and the applicant, the applicant may contact or arrange a meeting with EPA if help is needed to complete the application.

**COMMUNICATION IS KEY TO A TIMELY REVIEW OF THE APPLICATION AND ISSUANCE OF THE OPERATING APPROVAL**

EPA generally only accepts fully completed applications but may allow the applicant to submit a partial application if it will help minimize the likelihood of an unnecessary or deficient application. If a partial application is submitted, the applicant should clearly identify on the cover page that it is, in fact, a preliminary partial submission of an application. Also, if the document is a partial application, the applicant should clearly identify in the body of the application and table of contents those sections, items, figures/tables, etc. that will be provided later (and when, if known).

#### 4.1.2 Criteria

When developing an operating approval application, it is important to keep in mind regulatory standards, process criteria, and quality assurance/quality control (QA/QC) criteria. The standards listed below will help EPA ensure the alternate disposal method provides PCB destruction equivalent to disposal in a § 761.70 incinerator or a § 761.71 high efficiency boiler and will not present an unreasonable risk of

---

<sup>13</sup> As a reminder, trial burns and demonstration tests are referred to collectively as tests.

injury to health or the environment, as required under § 761.60(e). Individual approvals may include additional criteria not listed below, based on the specific nature of those technologies and processes, that are needed for EPA to make a no unreasonable risk determination.

Regulatory standards include:<sup>14</sup>

- $\leq 2$  ppm PCBs for all matrices (e.g., clean soil or dielectric fluid) except air and water;<sup>15</sup>
- $\geq 99.9999\%$  (six ‘9s’) DREs for PCBs in air emissions;<sup>16</sup>
- For incinerators and some thermal destruction technologies, the requirements, including operating parameters, for destruction of liquid and non-liquid PCBs as specified in § 761.70(a) and § 761.70(b), respectively;<sup>17</sup>
- $< 3$  ppb for water discharged to a treatment works or to navigable waters unless the discharge is in accordance with a PCB discharge limit included in a permit issued under the Clean Water Act;<sup>18</sup>
- $\leq 0.5$  ppb for water for unrestricted use;<sup>19</sup> and
- Any state regulatory standards that may apply.

Additional criteria may include:

- 90-110% isokinetic sampling;<sup>20</sup>
- Limits that may be imposed for other hazardous constituents that may be produced within the treatment process (e.g., buildup of an explosive gas such as H<sub>2</sub>);
- Other air quality standards (e.g., dioxins/furan standards adapted from Clean Air Act MACT standards) may be imposed under TSCA to ensure no unreasonable risk of injury to health or the environment;
  - This may be satisfied through a CAA permit instead, if applicable; and
- Monitoring, sampling, or control of any other aspects of the process that may pose an unreasonable risk of injury to health or environment.<sup>21</sup>

Additional criteria for non-thermal destruction/removal technologies will be dependent on the technology, and due to the variety of non-thermal technologies that exist, it is difficult to create a list of criteria that may be applicable to all non-thermal technologies. However, generally, non-thermal technologies may be requested to meet the criteria discussed above. Air emissions monitoring may not be required if the approval writer determines that no PCBs will be emitted based on the treatment

---

<sup>14</sup> All the regulatory standards listed here may not be applicable depending on method of treatment and disposal. For example, PCB-contaminated solids and liquids may be separated during an approved treatment process where the solids are sent to a TSCA landfill and the liquids are treated to  $\leq 2$  ppm.

<sup>15</sup> Previous guidance has interpreted that “equivalent level of performance” to an incinerator means less than or equal to 2 ppm. See “Guidelines for Permit Applications and Demonstration Test Plans for PCB Disposal by Non-Thermal Alternative Methods” (1986).

<sup>16</sup> 40 CFR 761.70(b)(1).

<sup>17</sup> See [section 2.3](#) of this guidance and § 761.70 for more information on regulatory incinerator requirements. An incinerator must meet all applicable requirements specified in § 761.70(a) and § 761.70(b), unless a waiver from these requirements is obtained pursuant to paragraph § 761.70 (d)(5).

<sup>18</sup> 40 CFR 761.50(a)(3).

<sup>19</sup> 40 CFR 761.30(u)(3).

<sup>20</sup> EPA Method 0010.

<sup>21</sup> Air emissions monitoring may not be required if the approval writer determines that no PCBs will be emitted based on the treatment process. Generally, thermal treatment processes will be required to monitor air emissions. However, non-thermal treatment processes may also be required to monitor air emissions, especially if there is potential for PCBs to volatilize.

process. However, if there is potential for PCBs to volatilize then air monitoring likely will be required.

Quality assurance criteria that EPA may consider are whether:

- Accuracy, precision, and representativeness of the data have been demonstrated;
- All data fall within the 70-130% range of EPA's values;
  - EPA personnel will typically take samples during the test for analysis;
  - EPA may also provide two Performance Evaluation (PE) samples to the applicant which should be analyzed and presented in the test report. One evaluation sample will generally contain PCB values near the concentration at which the feed will be demonstrated. The other evaluation sample will generally be close to the regulatory threshold;
  - Results of the samples collected and analyzed by EPA will be provided to the applicant; and
- Gas chromatograms and QA/QC supporting data validation have been provided.

EPA may also take into consideration other federal requirements, such as:

- National Historic Preservation Act (NHPA);
- Endangered Species Act (ESA); and
- Environmental Justice per Presidential Executive Order 12988.

#### ***4.1.3 Other Important Information for Development of an Approval Application***

Information provided within the approval application is assumed to be representative of the normal day-to-day operations when treating PCB waste, unless clearly specified otherwise. The applicant may request certain operating parameters for a test to be at the outer edges of their anticipated operating envelope (i.e., to test under a worst-case scenario) to ensure they receive an operating approval with conditions that allow them to operate their system at its optimal parameters, particularly when considering normal variability of these parameters. Differences between the day-to-day operation conditions and the test conditions should be discussed either in the application or the test plan. The applicant should clearly explain whether the operating levels proposed for the test will give them an adequate "cushion" between their normally anticipated operating levels and the levels demonstrated during the test which, in most instances, will become levels they cannot exceed during normal operations. The applicant may reference the test plan, if applicable. A more detailed discussion regarding this topic can be found in [section 5.1.1](#).

Note that the applicant may use the same unit to treat either TSCA regulated or non-TSCA regulated materials but the operational parameters specific to treating PCB waste should be provided in the application. Additionally, the applicant may be required to take certain steps (e.g., tank decontamination) prior to treating non-TSCA regulated waste in a unit which previously treated TSCA regulated waste. EPA may request more information on how the unit is used for non-TSCA related activities in order to make a no unreasonable risk determination.

Applicants should also keep in mind that, while it may be helpful to review and understand the requirements seen in other approvals, such requirements may not apply to their operating approval even if they use the same technology. Requirements in operating approvals depend upon many components of the application and observations during the test. For example, some facilities may choose to have an

extensive sampling regime and/or continuous monitoring equipment on all effluent sources after treatment. In such cases, EPA may be more lenient with operating parameter requirements in the approval. In turn, if the applicant chooses to have tight monitoring and operating parameter control over their system with “not to exceed” operating levels/limits then the need for effluent PCB sampling requirements may be reduced, if tested successfully. As an example, an incinerator treating PCB-contaminated oil will not have an effluent stream to sample so their monitoring and operating parameters may be strictly controlled in an operating approval. Whereas, hydrotreaters that treat PCB-contaminated oil have an effluent stream that can be sampled and EPA may be more lenient regarding the operating and monitoring parameters in the operating approval. In the end, EPA will consider the application in its entirety when determining appropriate approval conditions that ensure all regulatory requirements are met and it does not present an unreasonable risk of injury to health or the environment.

The information provided in this section, and this document in general, may not be comprehensive and applicants should or, in some instances, may be required to provide additional information when appropriate. Alternative PCB treatments cover a wide breadth of technologies and attempting to discuss every detail of every potential technology would make this document overwhelming and unreadable. However, this document will guide the applicant through the application process regardless of the technology they use and, at minimum, provide an idea of the information EPA is requesting in the application.

#### ***4.1.4 Research and Development Applications***

A facility seeking to use an uncommon or novel alternative disposal method should consider doing Research and Development (R&D). While R&D may not be a required step in obtaining an operational approval, it may assist in transitioning the treatment/disposal process from conception to commercial operation. Additionally, information from R&D studies can provide a proof of concept for novel or uncommon technologies that do not have established operating parameters for treating PCB waste. If the facility determines that R&D is not needed then they may skip this step. However, it is important to communicate this to EPA prior to developing the operating approval application because EPA may have a limited amount of information on the technology and may request that some information/data to be submitted prior to approving a test plan or an application.

R&D may be conducted without an approval when following the self-implementing guidelines pursuant to § 761.60(j). The self-implementing R&D provision allows less than 500 gallons of liquid PCBs or 70 cubic feet of liquid or non-liquid PCBs to be treated without an approval from EPA if the maximum PCB concentration does not exceed 10,000 ppm (see § 761.60(j)(1)(iii)). Note that there are notification requirements for self-implementing R&D (see § 761.60(j)(1)). When quantities greater than 500 gallons or 70 cubic feet, or concentrations greater than 10,000 ppm are to be treated in an R&D activity, either an approval or a waiver is required (see § 761.60(i) and § 761.60(j) respectively). R&D approvals may be issued for bench-scale, pilot-scale, and full-scale systems, but may not be used in lieu of a § 761.60(e) commercial approval. In other words, the main purpose of treatment operations in an R&D (see § 761.3) device must be to conduct research on the effectiveness of the process to treat/dispose of PCBs and PCB Items, as opposed to solely using the treatment device to treat/destroy PCBs and PCB Items.

Except for activities authorized under the self-implementing provisions for R&D for PCB disposal

(§ 761.60(j)), R&D activities involving less than 500 pounds of PCB material (regardless of PCB concentrations) will be reviewed and approved by the Director of ORCR, Regional Administrator, or delegated official, and R&D activities disposing of 500 pounds or more of PCB material (regardless of PCB concentrations) will be reviewed and approved by the Director of ORCR. Pursuant to § 761.60(j)(3), the authorized EPA official may determine at any time that an R&D PCB disposal approval is required, to ensure that the R&D for PCB disposal activity does not present an unreasonable risk of injury to health or the environment. EPA may limit the number of R&D runs for those R&D activities for which an EPA approval is required.

Approval applications for R&D activities that are not self-implementing activities should consist of all the applicable elements described below in this section (sections [4.2](#) and [4.3](#), except where noted). The R&D application need not contain the detail required for an operating approval application, but should be sufficient to demonstrate that the R&D activity will not present an unreasonable risk of injury to health or the environment. The applicant also should supply information on the specific objectives of the R&D activity. R&D approval applications can be submitted at any time, even if an application for an approval to operate commercially already has been submitted. As previously discussed, prior to developing and submitting an R&D approval application to EPA, the facility should proactively have discussions with the EPA approval writer to determine what types of information will be expected in the R&D approval application. In some cases, EPA may recommend that the applicant submit an operating approval application in lieu of the R&D approval application, depending upon the circumstances involved.

Upon receipt of an R&D approval application, EPA will review the document. If the application is incomplete or contains deficiencies, a notice of deficiencies will be sent to the applicant, who should then revise and resubmit the application. After EPA determines the facility's R&D approval application satisfies all applicable requirements, an R&D approval is issued. Alternatively, EPA may deny the approval application if the application does not satisfy the regulatory requirements, the application's deficiencies are not addressed within a reasonable period of time, or the technology presents an unreasonable risk of injury to health or the environment. In some instances, a draft approval is made available to the public for public comment. If this occurs, EPA will evaluate public comments and then determine whether the R&D approval should be issued with or without modifications, or denied.

The R&D results may be appropriate for inclusion in, for example, an application for an operating or test plan approval for the same technology. To use the results in an operating or test plan approval application, the R&D information should include process information and operating experience. This information should support the finding that full-scale operation of the technology will be equivalent to disposal in a § 761.70 incinerator or a § 761.71 high efficiency boiler and will not present an unreasonable risk of injury to health or the environment, as required under § 761.60(e). There also could be situations where the approval writer encourages or requires the facility to conduct R&D activities, or submit results of R&D activities previously conducted, prior to full scale testing if, for example, the technology is new or the technology has a limited track record with respect to treating their type/quantity of PCB waste.

#### ***4.1.5 Submitting Confidential Business Information (CBI)***

When preparing approval documents for submission to EPA, any information that the facility would like to be considered confidential business information (CBI) (as defined in 40 CFR part 2) should be clearly

identified. If a company's submittal to EPA contains CBI, they should submit one version of the submittal that contains the proprietary information to EPA, marked clearly as CBI, as well as a redacted version for the public and EPA personnel that are not certified to access CBI. The redacted version should not contain the CBI, but rather include a page(s) that clearly states, "Information on the original version sent to EPA has been claimed as confidential business information, and has been redacted from these pages." Contact EPA personnel to receive specific instructions for submitting CBI material.

#### ***4.1.6 Mobile Treatment Applications***

As stated in Table 1, applications for alternative disposal methods that are mobile and would be used in more than one EPA Region, must be submitted to the Director of ORCR at EPA Headquarters. Mobile treatment units present a unique set of challenges, particularly in the areas of public engagement, decontamination, and closure. Mobile treatment units should follow the same guidance in this document provided for stationary treatment units except when otherwise noted. Guidance specifically for mobile treatment units is interspersed throughout this document. For additional guidance, contact the ORCR PCB team at EPA Headquarters ([ORCRPCBs@epa.gov](mailto:ORCRPCBs@epa.gov)).

### **4.2 Contents of an Operating Approval Application**

Table 2 provides a suggested approval application format for incineration and alternative technologies. All subsections in this section apply to both incineration and alternative technologies unless otherwise noted in the subsection headings. [Appendix B](#) provides a checklist to aid the applicant in developing a complete approval application to operate a PCB incinerator or an alternative technology. This checklist is not required and does not need to be submitted to EPA.

In instances where the applicant is submitting a revised test plan, such changes/revisions should be summarized as described in [section 4.2.3](#), and if practicable, a redline/strikeout "compare" version that highlights the revisions should be provided.<sup>22</sup> To help facilitate EPA's review, the applicant is also encouraged to provide a standalone response to comments document that briefly explains/summarizes how each comment was addressed.

In instances where significant deficiencies have been identified by EPA, or the applicant is unclear as to how to address specific deficiencies, the applicant may find it useful to request a meeting or teleconference with the approval writer to best assure the revisions adequately address the comments received. EPA may deny the application if the deficiencies are not addressed within a reasonable period of time.

#### ***4.2.1 Transmittal Letter***

All operating approval applications should be accompanied by a transmittal letter, which summarizes the request for an operating approval and mentions relevant history of the request. If the test plan is being submitted in conjunction with an operating approval application, this should be briefly discussed in the transmittal letter. The transmittal letter of an updated application should summarize how it differs from the previously submitted application.

---

<sup>22</sup> In instances where significant revisions or rewrites have been made, a redline/strikeout compare version may not be practicable or useful.



### 4.2.2 Cover Page

Each approval application should have a cover page, an example of which is shown in Figure 2. If a paper copy is requested by EPA and if the application or the appendices are bound separately (i.e., multiple volumes), the applicant should number each volume in order in the upper right-hand corner of the cover (“Volume m of n”). The cover of each volume should also have all information shown in Figure 2.

**Table 2. Suggested Format for an Operating Approval Application**

<b>Section No.</b>	<b>Section Title</b>
	Approval Application Cover
	Table of Contents
I	Summary
II	Company Organization/Structure/Personnel
III	Waste Description and Analysis Plan
IV	Process Engineering Description
V	Monitoring and Sampling Plan
VI	Monitoring Procedures
VII	Sampling and Analysis Procedures
VIII	Data Recordkeeping and Reporting
IX	By-Product Waste Handling and Disposal
X	Inspection Procedures
XI	Spill Prevention Control and Countermeasures Plan
XII	Safety Plan
XIII	Training Plan
XIV	Test Plan Summary <sup>1</sup>
XV	Test Data or Engineering Performance Calculations
XVI	Other Permits and Approvals
XVII	Schedule of Pre-Operation Events
XVIII	Quality Assurance Project Plan
XIX	Standard Operating Procedures
XX	Closure Plan
	Appendices

<sup>1</sup>For an R&D approval, this section would present the planned research activities.

OPERATING APPROVAL APPLICATION, VERSION #X (IF APPLICABLE) <sup>23</sup>

PCB TREATMENT/DISPOSAL UNIT

*[Type and location of unit]*

*[Name and location of company headquarters if different from above]*

Operating Approval Application Submission Date: *[date]*

Test Plan Submission Date/Anticipated Date: *[date]*

Submitted by:

*[Company name and address]*

*[Principal manager  
and phone number]*

Submitted to:

Director, Office of Resource Conservation and Recovery

Office of Land and Emergency Management

U.S. Environmental Protection Agency

1200 Pennsylvania Avenue, NW

Mail Code 5303P

Washington, DC 20460

[ORCRPCBs@epa.gov](mailto:ORCRPCBs@epa.gov)

OR

If submitted to an EPA Regional office, provide the applicable Region's address listed at [www.epa.gov/pcbs/program-contacts](http://www.epa.gov/pcbs/program-contacts).

**Figure 2. Approval Application Cover Page Example.**

---

<sup>23</sup> If the document is revised and resubmitted to EPA, the applicant should clearly indicate on the cover that the report has been updated (e.g., version 2).

### ***4.2.3 Approval Application Section I - Summary***

The approval application should begin with a short summary presenting the document organization and any pertinent background information, such as a brief description of the company and the technology for which approval is requested. Be sure to discuss any unique aspects of the technology being utilized and point out significant differences, if any, relative to similar processes that are typically used in the industry. Summarize significant operating parameters that will be monitored and the sampling plan. If there are any previous application submissions or if a revision was requested by EPA, briefly discuss any significant changes made. If this is a renewal, briefly discuss past approvals and indicate any significant changes in the renewal application. In addition, the applicant should give a brief overview of their company and the operations at the facility requesting the approval, as applicable.

### ***4.2.4 Approval Application Section II - Company Organization/Structure/Personnel***

The organizational structure for the facility operation should be briefly described. An organizational chart identifying key individuals (position titles and actual personnel, if known) should also be provided. The organizational chart should include the owner, operator, and those personnel directly involved in the project, as well as the company's decision maker(s) for PCB treatment/disposal operations, (e.g., plant manager or superintendent). Relevant contractors should also be included if directly involved with the project. The corporate structure (e.g., relationship of company officers) is only necessary insofar as it affects the chain of command for the PCB treatment/disposal facility.

Personnel to be identified may include:<sup>24</sup>

- Owner (this may be a corporate entity and not necessarily a single person);
- Principal manager;
- Operations supervisor;
- Environmental compliance manager;
- Reviewing engineer;
- Maintenance supervisor;
- Quality assurance officer;
- Safety officer;
- Laboratory technician;
- Person(s) responsible for training;
- Person(s) responsible for demonstration test;
- Person(s) responsible for operation of monitoring system;
- Person(s) responsible for recordkeeping and reporting; and
- Other relevant personnel involved with the project.

---

<sup>24</sup> Personnel do not need to be identified for all of these roles, only those applicable to the organization, and one person may fulfill more than one role.

#### **4.2.5 Approval Application Section III - Waste Description**

A description of the waste(s) the applicant is requesting approval to treat/dispose of in the unit should be provided. This should indicate the characteristic of the waste(s) (e.g., soil, metal, paint, oil) and its phase (non-liquid or liquid). Expected PCB concentration in the waste(s) and known Aroclors, congeners, or homologs should be stated and the applicant should propose PCB feed rates or batch volumes. Include the composition of the waste(s), and discuss any constituents that may affect the treatment efficiency, the protectiveness of the treatment device outputs/effluents, and/or create operational hazards; this may include metals, pH, water, radiation, heating value, viscosity, chlorine concentration, ash, water content, other hazardous contaminants and potentially more.

#### **4.2.6 Approval Application Section IV - Process Engineering Description**

EPA needs sufficient information about the PCB treatment/disposal process to evaluate whether the operation of the system will: 1) comply with applicable PCB standards/requirements; and 2) not present an unreasonable risk of injury to health or the environment. EPA will also consider information from the test plan and the test results when making a decision on an approval.

The operating approval application should include detailed descriptions of the facility, PCB waste/item handling and storage equipment, treatment system process design, operation and anticipated performance, and pollution control equipment design and operation. To this end, the information that may be included in the application is presented in the following subsections as guidance. This is not necessarily all-inclusive; applicants should provide additional information when appropriate.

##### **4.2.6.1 General Information**

The following general information should be presented for the proposed PCB treatment/disposal facility:

- Facility location including site map; this should include a map that clearly shows the proximity of the facility and treatment unit to the surrounding community, water bodies, schools, local businesses, as well as stack height and/or emission points/locations. Include population and census data summaries, ecological receptors, topography maps, elevation of the facility relative to the 100-year flood water elevation, surface water runoff flow pattern, and locations of sewer manholes;
- Layout diagram and description of the treatment unit or mobile unit;
- Description of the theoretical basis for the destruction process;
- Detailed engineering drawings;<sup>25</sup>
- Process flow diagram (schematic diagram of the system) and narrative description;
- Descriptions and location of measurement devices to be used (e.g., flow meters, temperature and pressure measurement devices, weightometer);
- Intended operating locations of the mobile unit(s), if applicable (e.g., types of facilities or sites, specific states and EPA Regions);
- Intended storage location of the mobile unit(s) when not in use, if applicable; and
- Other information necessary for EPA to assess whether the facility or technology poses no unreasonable risk of injury to health or the environment.

---

<sup>25</sup> Provide a table that defines any labels, if they are not clear, for all drawings and diagrams.

#### ***4.2.6.2 Waste Feed System***

Provide a narrative description of the waste feed system (e.g., equipment and procedures for unloading, storage, and transfer of the PCB materials) and operational controls of the system; specifically, the secondary containment (e.g., drains, curbs, berms, total volume) and the systems that prevent/detect leakage and fugitive emissions. Also, describe the waste feed rate measurement method (e.g., pressure drops, flow meters, calibrated peristaltic pumps, scales, conveyor belts, operator observations).

If applicable, describe the waste preparation system such as filtration, distillation, blending with other wastes (including PCB wastes) and/or reagents and solvents, crushing, preheating, shredding, or hammering. Note that § 761.1(b)(5) states that “no person may avoid any provision specifying a PCB concentration by diluting the PCBs, unless otherwise specifically provided.” Any treatment step that involves dilution and/or blending should be specifically approved by EPA.

Determine the waste feed storage capacity, the expected average volume of waste feed stored on-site, and the expected average volume of total waste handled per month. Note that PCB waste storage may require a commercial storage approval pursuant to § 761.65(d). If required, such storage approval could be issued together with the treatment/disposal operating approval or as a separate approval. If the treatment/disposal technology is mobile, provide the waste capacity and average characteristics of waste stored in the mobile unit(s).

#### ***4.2.6.3 Automatic Waste Feed Cutoff System***

Describe the automatic waste feed cutoff system when process conditions deviate beyond the required operational limits that ensure destruction efficiency, compliant emissions, and safe operations, and discuss any time delay between when process conditions deviate beyond the required operational limits and when the feed is stopped. In most cases, waste feed should be ceased immediately upon any operating parameter exceeding allowable limits in the operating approval. The system should detect and record parameters at a frequency adequate to detect when a parameter is out of range, indicating that the waste feed should be cut off. Also, provide procedures to cut off the waste feed line and the whole process in the event of an equipment malfunction, recognizing that, for safety reasons, some process features (e.g., nitrogen blanket to prevent explosion) may not be appropriate to cut off.

Conditions in which a thermal treatment unit’s waste feed is cut off may include the following:

- Reactor/combustion chamber temperature is less than allowable;
- Excess O<sub>2</sub> value is lower than allowable (see requirements in § 761.70 (a)(1)(ii));
- Residence time is lower than allowable;
- Burner flameout occurs;
- CO and CO<sub>2</sub> concentration in exhaust gases are different from ranges allowed in the approval; and
- Other specific process conditions are different from those required by the approval (e.g., scrubber water flow rate is less than allowable);

Conditions in which a non-thermal treatment unit’s waste feed is cut off are generally more process-specific, but may include the following:

- Temperature and pressure are outside allowable ranges;
- Reagent flow rate is lower than allowable;
- Residence time in the reactor is lower than allowable or flow rate is higher than allowable; and

- Potentially other specific process conditions.

#### 4.2.6.4 PCB Destruction/Removal System

This guidance is separated by thermal and non-thermal destruction/removal technologies to help guide the reader toward the requirements that would apply to their technology. Thermal destruction technologies generally use high heat ( $> 500^{\circ}\text{C}$ ) and require air emissions monitoring and treatment process/operating parameter monitoring; this typically includes incineration, thermal desorption, or vitrification. Whereas, non-thermal destruction/thermal technologies destroy/remove PCBs typically in the absence of high temperatures, and do not require air emissions monitoring. This may include oxidation, catalytic hydrogenation, solvated electron technology, chemical dechlorination processes (i.e., sodium emulsion), or mechanochemical destruction. Applicants should remember that their technology may not fall exclusively into one category. For example, thermal desorption with a condenser or carbon filter will use slightly elevated temperatures (relative to an incinerator) to remove PCBs from a medium but the PCBs are generally not destroyed in the process. In this example, air emissions monitoring will likely be needed for EPA to determine whether its level of performance is equivalent to disposal in a § 761.70 incinerator or a § 761.71 high efficiency boiler and will not present an unreasonable risk of injury to health or the environment, as required under § 761.60(e). However, many of the operating conditions may be different from an incinerator and reviewing only the thermal sections of this guidance may not be comprehensive enough. If this is the case, then it is recommended that applicants review both thermal and non-thermal sections of this guidance.<sup>26</sup>

Information for applications specific to thermal destruction treatment systems may include:

- Detailed narrative description of the treatment/disposal unit. Include engineering data (such as chamber volume), temperature, flow rates, etc.;
- Engineering diagrams;
- Design capacity of the system;
- Volume of each reactor/combustion chamber(s);
- Target heating values for waste feed and auxiliary fuel to be used;
- Target feed rate for waste feed and auxiliary fuel to be demonstrated during the test;
- Target exit temperature of gases to be demonstrated during the test;
- Calculations showing the minimum residence time at the treatment temperature;
- Description of how flow rates are regulated so that the specified retention time is maintained;
- Normal operating values, target operating levels during the test, and acceptable ranges for operating parameters for which limits will be established based on levels demonstrated during the test (e.g., chamber temperature and pressure, volumetric flow rate, waste feed rate, retention time, air pollution control device [APCD] operating levels,  $\text{O}_2$ ,  $\text{CO}$ ,  $\text{CO}_2$ );
- Discussion of how operating parameters will be measured during the test and during normal operations (if different). Also, discuss measurement frequencies and averaging periods;<sup>27</sup>
- Expected destruction removal efficiency of this unit, based on design criteria or pilot tests;
- PCB mass balance calculation; and

<sup>26</sup> Note that air emissions monitoring may be different during the test compared to normal operations. The applicant should point out these differences in either the test plan or the application.

<sup>27</sup> It is suggested to discuss operating parameter values, ranges, measurement frequencies, and averaging periods with your approval writer. EPA may have specific requirements to include in the operating approval which will impact how the test is designed and target operating parameter levels are set.

- Information on similarly designed treatment/disposal systems, descriptions/summaries of key differences (if applicable), and their use for treating waste (with summaries of results, if available).

Information for applications specific to non-thermal destruction/removal treatment systems may include:

- Detailed narrative description of the treatment/disposal unit. Include a description of the chemical reactions, stoichiometry, reagents, catalysts, temperature, flow rate, etc.;
- Engineering diagrams;
- Design capacity of the reactor and/or the system;
- List of products and by-products and their expected concentrations;
- Description of reactant/oxidant/fuel/catalyst feed rates and how they are monitored;
- Detailed description of the unique engineering features of the process (e.g., condensers, residence time, heat transfer);
- Description of any regeneration/recycling processes applied in the system;
- Normal operating values, target operating levels during the test, and acceptable ranges for operating parameters for which limits will be established based on levels demonstrated during the test (e.g., chamber temperature and pressure, flow rate, waste feed rate, retention/contact time) being measured;
- Discussion of how operating parameters will be measured during the test and during normal operations (if different). Also, discuss measurement frequencies and averaging periods;<sup>28</sup>
- Expected destruction removal efficiency of this unit, based on design criteria or pilot tests;
- PCB mass balance calculation; and
- Information on similarly designed treatment/disposal systems, descriptions/summaries of key differences (if applicable), and their use for treating waste (with summaries of results, if available).

Remember that the information provided for both thermal and non-thermal destruction/removal technologies should be based on anticipated normal day-to-day operations for destroying/removing PCBs.<sup>29</sup> Target operating values should be included and, when applicable, acceptable operating ranges should also be mentioned. The designed operating parameters of certain components of the system may also be required, especially if the technology is unique or unfamiliar, to ensure no unreasonable risk of injury to health or the environment. If the applicant is requesting a renewal, the operating values may be based on the previous approval unless the applicant is requesting to operate under different operating values.

The operating limits stated in the operating approval for both thermal and non-thermal destruction/removal technologies are typically based on the results of the demonstration test. The applicant should carefully plan their test such that DRE and other standards are met and that the test operating conditions lead to a set of approval conditions that are workable for anticipated day-to-day operations. This is discussed in more detail in [section 5.1.1](#). Exceeding the operating limits stated in the operating approval would result in a violation of the approval, which may result in suspension or termination of the operating approval.

---

<sup>28</sup> It is suggested to discuss operating parameter values, ranges, measurement frequencies, and averaging periods with your approval writer. EPA may have specific requirements to include in the operating approval which will impact how the test is designed and target operating parameter levels are set.

<sup>29</sup> See [section 5.1.1](#) for more information.

#### ***4.2.6.5 Pollution Control System (PCS)***

A complete description of the PCS for process effluents (air emissions, liquid effluents, sludge, solid waste, etc.) should be provided. In addition to providing diagrams of the system, information on the major design parameters, how they affect performance, and how they will be monitored, should be included. Include all parameters that are necessary to be monitored and controlled to assure compliance with regulatory (and subsequent operating approval) requirements. Major design parameters will be dependent on the PCB treatment/disposal system and may include:

- Total effluent flow rate (may be gas or liquid);
- Pressure drop across the system;
- Exhaust gas or liquid temperature after treatment;
- Type and concentration of pollutants (control system inlet and outlet) if available;
- Design pollution removal efficiency (provide basis, including calculation and/or data/info);
- Expected concentration of PCBs that may be captured (e.g., baghouse material);
- Treatment residence time;
- Minimum reactor/combustion chamber temperatures(s);
- Gas temperature ranges within the dry air pollution device (if equipped with a dry air pollution control device); and
- Other parameters, as necessary.

Operating parameters for treatment systems, including associated APCDs, will typically be dependent on the treatment unit design and the APCD used, and may be specific to the target pollutant being controlled (e.g., PCB, particulate matter [PM], dioxin/furan, or HCl emissions). For example, parameters assuring proper PCB destruction efficiency may be different from those operating parameters necessary to control PM emissions. When assessing applicable and appropriate operational parameters, it is suggested that these parameters be identified up front (in both the operating approval application as well as the demo test plan) based on the target pollutant to be controlled.

We note that most TSCA incinerators are also permitted to treat hazardous waste in accordance with the Clean Air Act (CAA) and Resource Conservation and Recovery Act (RCRA) requirements, and the compliance approach described above is currently required under the Clean Air Act for incinerators that treat hazardous waste (see § 63.1209(j) thru (p) for CAA requirements and 40 CFR parts 260 through 270 for RCRA requirements).<sup>30</sup>

As such, permittees of these incinerators are likely already familiar with the compliance approach discussed above. Therefore, operating parameters deemed necessary by the TSCA approval writer may be similar to those already required under RCRA or CAA regulations and would likely not be new or pose additional burden to the facility.

---

<sup>30</sup> Prior to finalizing the Hazardous Waste Combustion MACT standards, EPA also issued a guidance titled: “Operational Parameters for Hazardous Waste Combustion Devices” (EPA/625/R-93/008, October 1993), “Permit Writers Guide to test Burn Data,” EPA/625/6-86/012, (September 1986), as well as “Guidance on Setting Permit Conditions and Reporting Trial Burn Results,” EPA/625/6-89/019). These documents may also be useful when assessing applicable operating parameters that may be necessary to assure compliance with the TSCA PCB emission limitations or to assure the PCB treatment/disposal unit does not present an unreasonable risk of injury to health or the environment.



Below are a few examples of specific pollution control devices and their respective operating parameters:

- **Scrubber** - Scrubber liquid flow rate, pressure drop across mist eliminator, makeup liquid flow rate, nozzle operating pressure, pH of scrubbing liquid, liquid discharge rate, lime or other conditioning agent feed rate, liquid/gas flow rate, and potentially others.
- **Fabric Filter** - Differential static pressure between clean and dirty side, dew point of gases, description of temperature protection device or fabric filter bypass system, air/cloth ratio, bag material (resistant to chemical and physical properties of the stack gas), description of bag cleaning system, system for ash removal, and potentially others.
- **Electrostatic Precipitator (ESP)** - Number of fields, number of transformer-rectifier sets, total plate area, primary voltage, primary current, ESP voltage (secondary), ESP current (secondary), spark rate, description of rapper system, system for ash removal, dust level in hopper indicator, and potentially others.

Information on the normal operating values and acceptable ranges for significant operating variables should be included. If information is available in the form of vendor-supplied performance specifications, it may be substituted. The waste streams of the associated treatment process (e.g., ESP ash, scrubber liquid, incinerator ash, baghouse dust, carbon) should be discussed, including the method for disposing of the waste. Also, provide a description of the warning system, if any, used to signal PCS malfunction.

#### *4.2.6.6 Compendium of All Process Operating Parameters*

Provide a table that lists all measured operating parameters, instrument settings, and control equipment parameters and, for each parameter, provide the target operating value, operating range (i.e., upper and lower boundaries), and averaging time (or indicate if measured instantaneously). All values should be reported in common, consistent units. The application also should describe the action to be taken whenever a parameter deviates outside the control limits. These actions may include adjusting the operating conditions, stopping the PCB feed, shutting down the process, etc. The time allowable for corrective action before shutdown or other actions should be specified.

#### *4.2.7 Approval Application Section V - Monitoring and Sampling Plan*

This section of the application provides the details of the monitoring and sampling to be conducted during normal PCB treatment operations. Any monitoring and sampling activities specific to only the test should be discussed in the test plan (see [section 5.2.5](#)). The applicant should develop a monitoring and sampling plan to monitor process operation and verify that the PCB treatment/disposal achieves the level of performance equivalent to disposal in a § 761.70 incinerator or a § 761.71 high efficiency boiler and will not present an unreasonable risk of injury to health or the environment, as required under § 761.60(e). These plans should also summarize the monitoring and sampling of the emissions, effluent parameters, and pollution control equipment for the specific treatment process. The objective should be to obtain results that are representative of the conditions at which the unit is operating. In cases where samples may not be representative of the conditions at which the unit is operating, a worst-case result should be obtained (i.e., sample when the process is least likely to achieve the required treatment standards). In cases where problems can be anticipated (e.g., instrument failure), contingencies should be included in the monitoring and sampling plan. A tabular format, with narrative explanation, as

necessary, can be used to summarize the monitoring and sampling plan.

Note that information in this section may overlap with information discussed in subsequent sections (i.e., monitoring procedures and sampling procedures, [section 4.2.8](#) and [section 4.2.9](#), respectively). This section is intended to discuss what methods will be used and where/how each will be applied in the treatment process. Discussion of the method itself and how each method is conducted is found in the subsequent sections. There is some overlap between these sections and the applicant may combine the monitoring and sampling plan and methods into one section of their application, but should be sure to review and include applicable information discussed in all three sections within this guidance (sections [4.2.7](#), [4.2.8](#), and [4.2.9](#)). Remember that there are some subtleties between each section, for example, measurement frequency could refer to the frequency used during normal operation, during the demonstration test, or the measurement frequency capabilities of the instrument; all three may be different. Furthermore, the recording frequency may differ from the measurement frequency.

Generally, the monitoring and sampling plan for both thermal and non-thermal destruction/removal technologies should discuss the following basic information:

- Process parameters to be monitored;
- Monitoring locations;
- Monitoring methods;
- Monitoring frequencies;
- Effluent streams to be sampled;
- Sampling locations;
- Sampling methods;
- Sampling frequencies;
- Analysis methods; and
- Acceptable operating limits to meet effluent criteria (see [section 4.1.2](#) for criteria).

There are several parameters that the Agency may require to be monitored and sampled depending on the treatment/disposal unit, such as: waste feed rates, reactor temperature, residence time, emissions, pollution control devices, and others. When discussing the parameters to be monitored and sampled, the application should:

- Present the location and provide a brief description of the system or monitoring/sampling process;
  - Breakdown into discrete activities (e.g., stack emissions, combustion chamber operating parameters, APCD operating parameters, liquid waste, ash, product);
- Discuss the monitoring/sampling objective for each location (e.g., collect a “representative” sample; monitor and record combustion zone temperature; establish APCD operating limits; follow an EPA test protocol; or collect a “worst-case” sample);
- List the substance or property to be monitored/sampled at each location;
  - Monitored parameters may include O<sub>2</sub>, CO, CO<sub>2</sub>, temperature, or pressure;
  - Sampling parameters may include the list of the compounds to be analyzed and media characteristics;
- List the cleanup, extraction, and analytical methods to be used;
- Discuss the monitoring and sampling design for each location. Include a mathematical design or a reference to a standard protocol, as needed;
  - The monitoring design should include the measurement frequency (e.g., every second,

every 15 minutes), averaging time, recording frequency, and any timing delay (e.g., any time between reaching steady-state conditions and when monitoring began);<sup>31</sup>

- Anticipated operating ranges for these monitored parameters should be specified in the process engineering information, as described previously in [section 4.2.6](#);
- A justification may be required if the frequency of measurement/recording times are longer than typical industry standards at the time the application is received by EPA or if the measurement frequency is longer than what EPA believes is needed to prevent an unreasonable risk of injury to health or the environment;
- The sampling design should include the frequency (e.g., once per batch), size (e.g., 100 grams), timing (e.g., at the end of each batch run), number of replicates (e.g., duplicates for 10 percent of the samples or 2 samples, whichever is greater), and the total number of samples should be listed for each sample type;
  - An estimate of the sample representativeness. This may be based on data (e.g., historical data on replicates) or scientific/engineering judgment (e.g., a sample from an actively mixed feed tank could be characterized as representative);
  - Indicate if grab or composite sampling is used at each location and describe the procedure;
  - A justification may be required if the frequency of sampling is longer than typical industry standards at the time the application is received by EPA or if the sampling is less than what EPA believes is needed to prevent an unreasonable risk of injury to health or the environment;
- Include contingencies for action if monitoring data cannot be collected according to plan (e.g., alternative sampling sites or times, an entirely new sampling plan, or repeat tests); and
- Discuss any safety considerations to prevent injury to workers or the local community (e.g., integrity measurements, pressure control measures, measurement of the buildup of hazardous constituents, etc.).

The following subsections differentiate the monitoring and sampling requirements specific to thermal and non-thermal destruction/removal technologies.

#### ***4.2.7.1 Monitoring and Sampling Plan for Incineration and Alternative Thermal Destruction Technologies***

Destruction of PCBs by thermal methods should, at a minimum, follow the requirements established in § 761.70(a). For example, monitoring and recording should be conducted for O<sub>2</sub>, CO, and CO<sub>2</sub> whenever the thermal unit is used to destroy PCBs. Provide the frequency that O<sub>2</sub>, CO, and CO<sub>2</sub> measurements are taken and the interval that a value is recorded.<sup>32</sup>

Pursuant to § 761.70, when a thermal unit is first used to destroy PCBs or following a modification to the incinerator that may affect the characteristics of the stack emission products, monitoring of the stack emission products should be conducted for O<sub>2</sub>, CO, CO<sub>2</sub>, NO<sub>x</sub>, HCl, RCl (residual chloride compounds), PCBs, and total particulate matter. The measurement of these parameters is discussed in [section 5](#) (Test

---

<sup>31</sup> Note that, in some instances there is a difference between a measured value and a recorded value. For example, during continuous emissions monitoring a measured value may be taken every 15 seconds and a value may be recorded every 60 seconds.

<sup>32</sup> See [section 2.3](#) of this guidance for incinerator requirements.

Plans) of this document.

In addition to those required by § 761.70, an applicant should propose any additional monitoring and sampling parameters that are necessary to ensure the operation of the PCB treatment/disposal unit does not present an unreasonable risk of injury to health or the environment and, for an applicant for an alternative technology, to verify that PCB destruction is equivalent to disposal by incineration.<sup>33</sup> The approval writer may determine it necessary for the facility to monitor/sample more parameters during normal operations to assure compliance with PCB regulatory requirements and/or assure operation of the incinerator does not present an unreasonable risk of injury to health or the environment. Additional parameters will vary based on the design of the treatment/disposal unit and associated pollution control systems, as applicable. Example additional operating parameters include, but may not be limited to:

- PCB concentration in the waste feed to calculate the Destruction and Removal Efficiency (DRE);
- Polychlorinated Dibenzo-p-dioxin (PCDD) and Polychlorinated Dibenzofuran (PCDF) (tetra- through octachloro homologs, 2,3,7,8-tetrachlorodibenzodioxin, and 2,3,7,8-tetrachlorodibenzofuran) in the stack emissions; and
- PCB, PCDD, and PCDF concentrations in any solid or liquid wastes generated.

The monitoring and sampling plan also should identify the appropriate combustion system and pollution control system operating parameters that will be monitored and recorded during normal operations (e.g., minimum residence time, batch feed operating parameters, liquid waste atomization parameters, scrubber water flow rate, pressure drop).

A schematic diagram can be used to illustrate the monitoring points; Figures 3 and 4 are examples for an incinerator and a thermal desorber, respectively. The specific location of the sampling point should be discussed briefly in the narrative (e.g., the liquid waste sample will be collected from the feed line just prior to the injection nozzle). Other important parameters of the monitoring plan can be concisely presented in a tabular format; Tables 3 and 4 provide example summary tables of monitoring and sampling parameters for incinerators. Tables 5 and 6 provide summary examples of monitoring and sampling plans for an alternative thermal destruction technology.

Note that in the tables below stop operation/repair system (SORS) means to immediately stop feeding PCB waste into the treatment system and potentially shut the PCB treatment process down for repairs. Batch processes may need to restart the treatment process for the same batch after repairing. The entire system may not need to be shut down but treatment of PCB waste should stop until the system is repaired. Facilities should utilize their automatic waste feed cutoff systems and other standard protocols developed for shutting down their system and/or making repairs.

---

<sup>33</sup> 40 CFR 761.70(d)(4)(ii), 60(e).

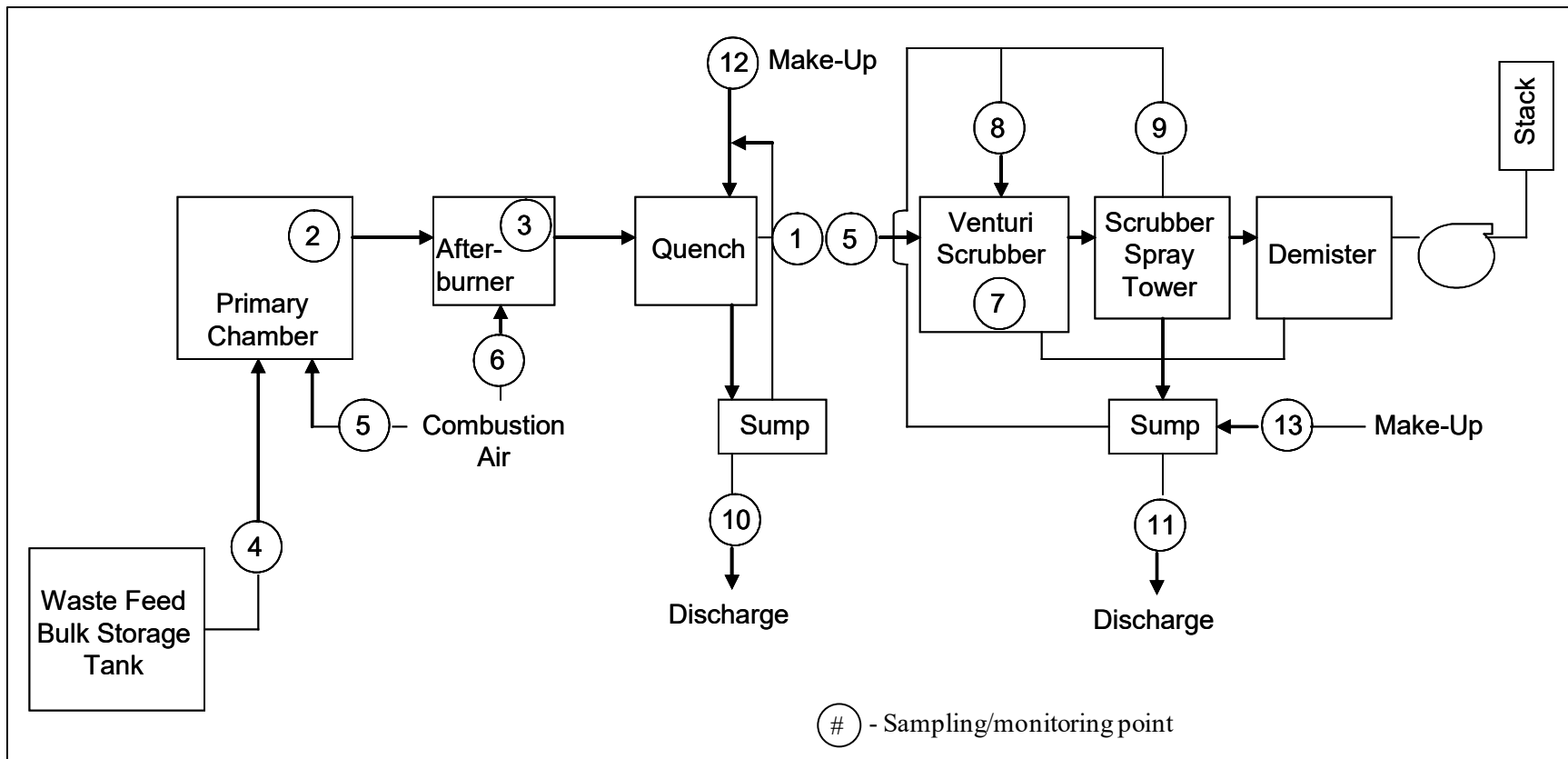

**Figure 3. Example Schematic of Monitoring and Sampling Points for an Incinerator (see Tables 3 and 4 for monitoring and sampling parameters)**

**Table 3. Example Summary of Monitoring Parameters for Incinerators <sup>1</sup>**

DISCLAIMER: This table is only an example and may not capture every relevant parameter, nor is every parameter listed in the table relevant to all technologies. Furthermore, applicants are not required to use this table or submit it to EPA.

Parameter	Method	Frequency	Location	Target Value	Backup to Monitoring Instrument
Oxygen	Continuous emissions monitor (CEM)	[To be determined (TBD)]	1	5.5 %	Stop Operation/Repair System (SORS)
Carbon monoxide (CO)	CEM	[TBD]	1	20 parts per million (ppm)	SORS
Carbon dioxide (CO <sub>2</sub> )	CEM	[TBD]	1	12 %	SORS
Combustion temperature	Shielded thermocouple	[TBD]	2, 3	1250 °C	SORS
Incinerator pressure	Pressure transducer	[TBD]	2, 3	[negative pressure] atm	SORS
Waste feed rate	Volumetric or mass flow meter	[TBD] <sup>2</sup>	4	[TBD] kilograms per hour (kg/hr)	SORS
Residence time	Gas velocity (Annubar <sup>®</sup> )	[TBD]	5, 6	2.2 seconds	SORS
Combustion efficiency	Automated calculation	[TBD]	NA	99.9%	Manual calculation
Venturi pressure drop	Pressure transducer	[TBD]	7	[TBD] inches of water (in H <sub>2</sub> O)	SORS
Venturi scrubber liquid flow	Rotameter	[TBD]	8	[TBD] gallons per minute (gpm)	SORS
Spray tower liquid flow	Rotameter	[TBD]	9	[TBD] gpm	SORS
Quench water discharge	Volumetric flow meter	[TBD]	10	[TBD] gpm	SORS
Scrubber liquid discharge	Volumetric flow meter	[TBD]	11	[TBD] gpm	SORS
Quench water make-up	Volumetric flow meter	[TBD]	12	[TBD] gpm	SORS
Scrubber liquid make-up	Volumetric flow meter	[TBD]	13	[TBD] gpm	SORS
PCB emissions to ambient air	EPA SW-846 Method 0010	[TBD]	NA	99.9999 DRE of PCBs	SORS
Dioxin/Furan emissions to ambient air	EPA SW-846 Method 0023A	[TBD]	NA	[TBD] ppm	SORS

<sup>1</sup> Location points refers to Figure 3.

<sup>2</sup> No less frequent than every 15 minutes. See § 761.70(a)(3).

**Table 4. Example Summary of a Sampling Plan for Incinerators <sup>1</sup>**

DISCLAIMER: This table is only an example and may not capture every relevant parameter, nor is every parameter listed in the table relevant to all technologies. Furthermore, applicants are not required to use this table or submit it to EPA.

Parameter	Sampling/Extraction Method	Sampling Frequency	Location	Analysis parameters	Analysis methods	Target Value	Backup Plan for Sample Collection, Extraction, or Analysis
Waste feed	Composite sample, Method 3540	[To be determined (TBD)]	1	PCB homologs	SW-846 Method 8082	Not applicable (NA)	Hold batch until sample obtained
Ash/Residue	Composite sample, Method 3540	[TBD]	NA	PCB homologs	SW-846 Method 8082	≤ 2 parts per million (ppm)	Hold batch until sample obtained
Quench water discharge	Grab sample, Method 3540	[TBD]	10 and 11	PCB homologs	EPA Method 608	≤ 0.5 parts per billion (ppb)	Hold batch until sample obtained

<sup>1</sup> Location refers to Figure 3.

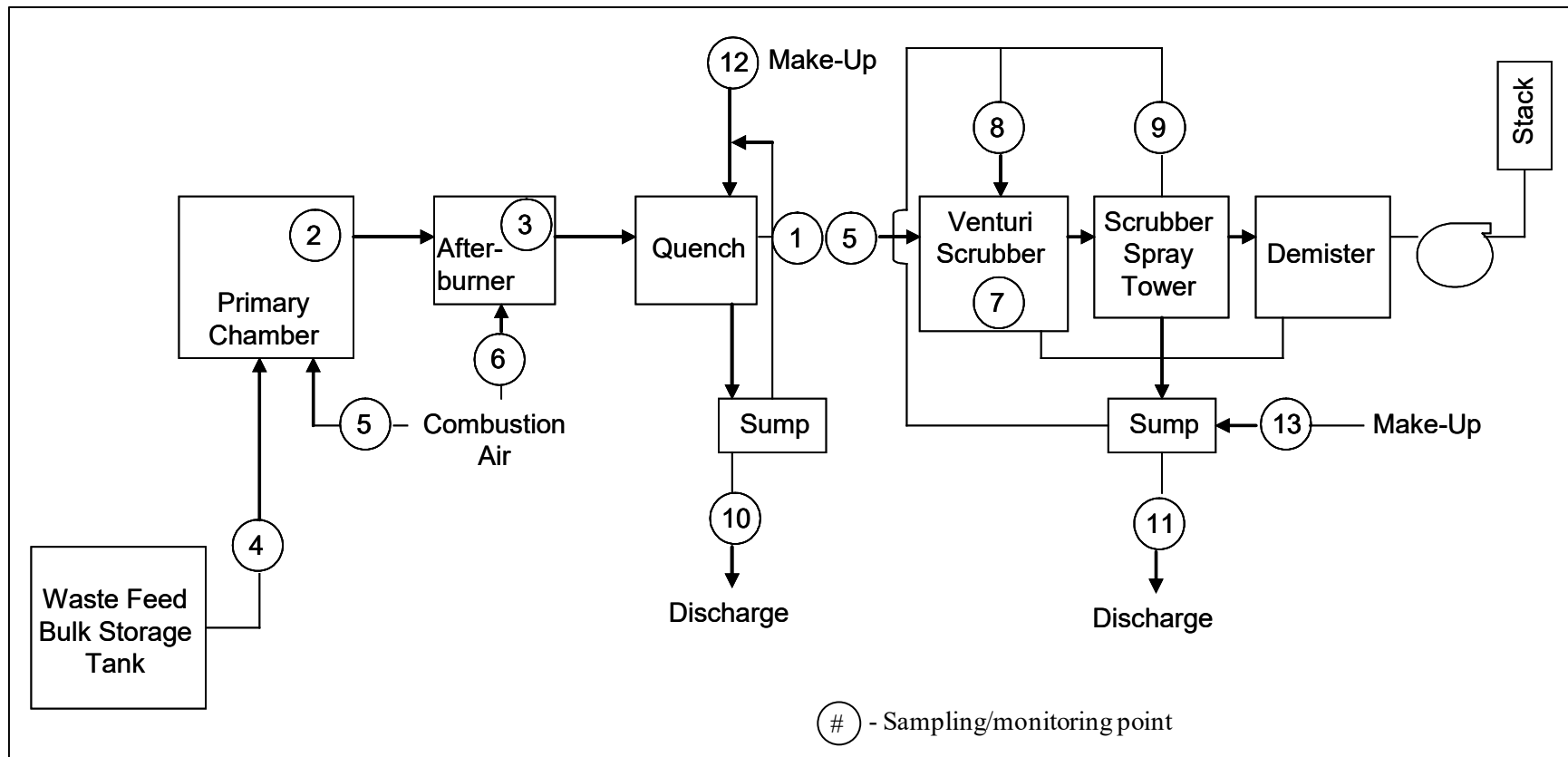

**Figure 4. Example Schematic of Monitoring and Sampling Points for a Thermal Desorber Unit (see Tables 5 and 6 for sampling and monitoring parameters).**



**Table 5. Example Summary of Monitoring Parameters for an Alternative Thermal Destruction Technology <sup>1</sup>**

DISCLAIMER: This table is only an example and may not capture every relevant parameter, nor is every parameter listed in the table relevant to all technologies. Furthermore, applicants are not required to use this table or submit it to EPA.

Parameter	Method	Frequency	Location	Target Value	Backup to Monitoring Instrument
Oxygen	Continuous emissions monitor (CEM)	[TBD]	9	[TBD] %	Stop Operation/Repair System (SORS)
Carbon monoxide (CO)	CEM	[TBD]	9	[TBD] ppm	SORS
Carbon dioxide (CO <sub>2</sub> )	CEM	[TBD]	9	[TBD] %	SORS
Waste feed rate	Volumetric or mass flow meter	[TBD] <sup>2</sup>	1	[TBD] kg/hr	SORS
Dryer temperature	Thermocouple	[TBD]	2, 3	[TBD] °F	Rely on redundant thermocouples. Repair/replace within 1 day or stop operation.
Product temperature	Thermocouple	[TBD]	2, 3	[TBD] °F	Rely on redundant thermocouples. Repair/replace within 1 day or stop operation.
Carrier gas temperature	Thermocouple	[TBD]	2, 3	[TBD] °F	Rely on redundant thermocouples. Repair/replace within 1 day or stop operation.
Dryer internal pressure	Pressure transducer	[TBD]	2, 3	[TBD] in. WC	Rely on local pressure indicator Repair/replace within 1 day or stop operation.
Carrier gas temperature	Thermocouple	[TBD]	Condenser system inlet	[TBD] °F	Replace thermocouple. Rely on local temperature indicator.
Carrier gas temperature	Resistance-Temperature Detector (RTD)	[TBD]	Condenser system outlet	[TBD] °F	Rely on redundant RTD. Repair/replace within 1 day or stop operation.
Gas system differential Pressure	Pressure transducer	[TBD]	Gas System	[TBD] in. WC	Rely on local pressure indicator. Repair/replace within 1 day or stop operation.
Residence time	Gas velocity (Annubar <sup>®</sup> )	[TBD]	2, 3	[TBD] seconds	SORS
Bag house pressure drop	Pressure transducer	[TBD]	4	[TBD] in. WC	SORS
Quench water discharge	Volumetric flow meter	[TBD]	6	[TBD] gpm	SORS
Quench tower liquid flow	Rotameter	[TBD]	7	[TBD] gpm	SORS
Process vent flow	Flow meter	[TBD]	9	[TBD] cfm	Repair or replace meter. Rely on valve position and dryer pressure to control flow.

Table continued from previous page.

Parameter	Method	Frequency	Location	Target Value	Backup to Monitoring Instrument
Nitrogen flow	Flow meter	[TBD]	Nitrogen feed line	[TBD] standard cubic feet per minute (SCFM)	Repair or replace flow meter. Rely on O <sub>2</sub> conc. and dryer pressure to control N <sub>2</sub> flow.
Pre-filter differential pressure	Press indicator	[TBD]	8	[TBD] inches water column (in.WC)	Replace during normal maintenance.
HEPA filter differential pressure	Press indicator	[TBD]	8	[TBD] in.WC	Replace during normal maintenance.
PCB emissions to ambient air	EPA Method 0010	[TBD]	9	[TBD] %	SORS

<sup>1</sup> Location points refers to Figure 4.

<sup>2</sup> But no less frequent than every 15 minutes, consistent with § 761.70(a)(3).

**Table 6. Example Summary of a Sampling Plan for an Alternative Thermal Destruction Technology <sup>1</sup>**

DISCLAIMER: This table is only an example and may not capture every relevant parameter, nor is every parameter listed in the table relevant to all technologies. Furthermore, applicants are not required to use this table or submit it to EPA.

Parameter	Sampling/Extraction Method	Sampling Frequency	Location	Analysis parameters	Analysis methods	Target Value	Backup Plan for Sample Collection, Extraction, or Analysis
Waste feed	Grab sample, EPA Method 3540	[To be determined (TBD)]	1	PCB homologs	EPA Method 8082	Not Applicable (NA)	Hold batch until sample obtained
Water Discharge	Grab sample, EPA Method 3540	[TBD]	6	PCB homologs	EPA Method 608	≤ 0.5 ppb	Hold batch until sample obtained
Treated Stockpile	Composite sample, EPA Method 3540	[TBD]	10	PCB homologs	EPA Method 8082	≤ 2 ppm	Hold batch until sample obtained
Carbon Breakthrough	EPA Method 3540	[TBD, periodically to check for breakthrough]	8	PCB homologs	EPA Method 8082	≤ 2 ppm	Hold batch until sample obtained

<sup>1</sup> Location refers to Figure 4.

#### ***4.2.7.2 Monitoring and Sampling Plan for Alternative Non-Thermal Destruction/Removal Technologies***

A monitoring and sampling plan for non-thermal processes should verify that the PCB treatment/disposal unit achieves a level of performance equivalent to disposal in a § 761.70 incinerator or a § 761.71 high efficiency boiler and will not present an unreasonable risk of injury to health or the environment, as required under § 761.60(e). This may not be straightforward as it will depend on the type of non-thermal treatment unit. At a minimum, this will include measurements of PCBs in the final product and effluent streams (wastewater, filters, vent gas, treated oil, etc.). For separation treatment processes (e.g., carbon filtration) where PCBs are concentrated into a fraction for subsequent treatment/disposal by an approved method, the applicant should propose a set of monitoring and sampling parameters to verify that (a) the residual “clean” fraction contains  $\leq 2$  ppm PCBs (see [section 2.4](#)), (b) levels of PCBs emitted from the system through drains, vents, etc. are within regulatory standards, and (c) the process does not present an unreasonable risk of injury to health or the environment. The monitoring and sampling parameters will depend upon the process design and the waste feed and effluent streams associated with the alternative treatment/disposal method. Process operating parameters that affect performance of the unit (e.g., feed rate, reaction temperature, and pressure) should be monitored and recorded. The applicant should describe all the operating parameters that are necessary to assure compliance with the PCB regulations and to ensure no unreasonable risk of injury to health or the environment in the monitoring and sampling plan. This would include pollution control system operating parameters, if applicable.

A schematic diagram can be used to illustrate the monitoring and sampling locations; Figure 5 is an example. The diagram should depict the specific location of each sampling point and sampling locations should further be discussed in the narrative. Because each alternative method for treatment/disposal of PCBs is uniquely different, the applicant should specify the process parameters that will be monitored and the effluent streams that will be sampled during normal operations. Table 7 is an example of a tabular summary of monitoring parameters for a chemical dechlorination process. Table 8 provides an example of a sampling plan for a chemical dechlorination method.

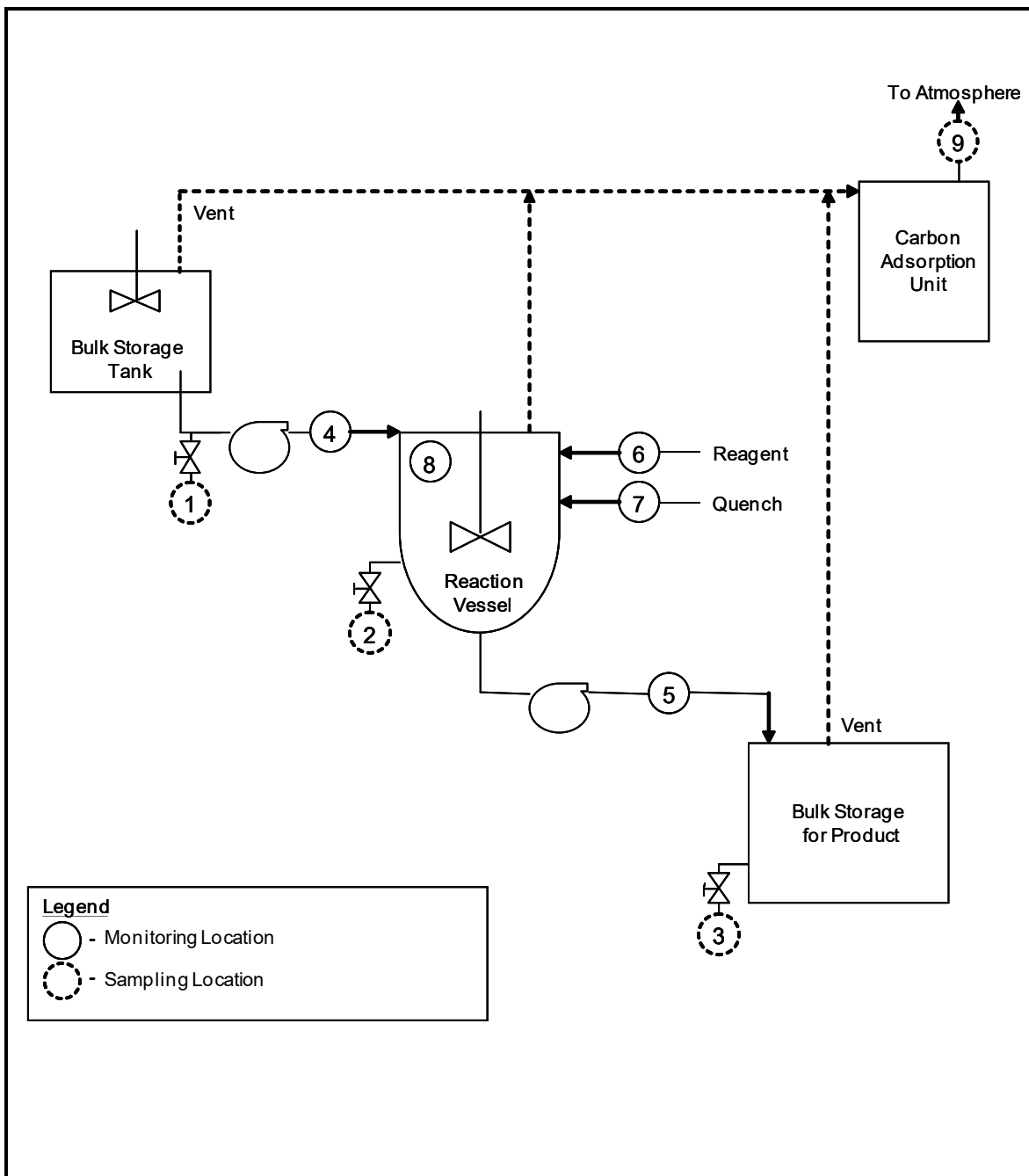

**Figure 5. Example Schematic of Monitoring and Sampling Points for a Chemical Dechlorination Process (see Tables 7 and 8 for monitoring and sampling parameters).**

**Table 7. Example Summary of Monitoring Parameters for a Chemical Dechlorination Process <sup>1</sup>**

DISCLAIMER: This table is only an example and may not capture every relevant parameter, nor is every parameter listed in the table relevant to all technologies. Furthermore, applicants are not required to use this table or submit it to EPA.

Parameter	Method	Frequency	Location <sup>1</sup>	Target Value	Backup to Monitoring Instrument
Waste feed rate	Volumetric or mass flow meter	[To Be Determined (TBD)]	4	[TBD] kg/hr	Stop Operation/Repair System (SORS)
Product flow rate	Volumetric or mass flow meter	[TBD]	5	[TBD] kg/hr	SORS
Reagent feed rate	Volumetric or mass flow meter	[TBD]	6	[TBD] gpm	SORS
Quench feed rate	Volumetric or mass flow meter	[TBD]	7	[TBD] gpm	SORS
Residence time	Manually calculate	[TBD]	NA	[TBD] minutes	Manually Calculate
Reaction vessel pressure	Pressure transducer	[TBD]	8	[TBD] in. WC	SORS
Reaction vessel temperature	Thermocouple	[TBD]	8	[TBD] °F	SORS
Vent emissions	Total hydrocarbon analyzer	[TBD]	9	[TBD]	SORS

<sup>1</sup> Refers to Figure 5.

**Table 8. Example Summary of a Sampling Plan for a Chemical Dechlorination Process <sup>1</sup>**

DISCLAIMER: This table is only an example and may not capture every relevant parameter, nor is every parameter listed in the table relevant to all technologies. Furthermore, applicants are not required to use this table or submit it to EPA.

Parameter	Sampling/Extraction method	Sampling Frequency	Location <sup>1</sup>	Analysis parameters	Analysis methods	Target Value	Backup Plan for Sample Collection, Extraction, or Analysis
Waste feed	Grab sample, EPA Method 3540	[To Be Determined (TBD)]	1-Storage tank line tap	PCB homologs	EPA Method 8082	Not Applicable (NA)	Hold batch until sample obtained
Process product	Grab sample from reactor tap	[TBD]	2-Reactor vessel line tap	PCB homologs	EPA Method 8082	≤ 2 ppm	Hold batch until sample obtained
	Grab sample from storage tank	[TBD]	3-Product storage tank	PCB homologs	EPA Method 8082	≤ 2 ppm	Hold batch until sample obtained

<sup>1</sup> Location refers to Figure 5.

#### 4.2.8 Approval Application Section VI - Monitoring Procedures

For facilities using monitoring systems, a detailed discussion of the monitoring methods that will be used during normal operations should be included in this section of the approval application. The discussion for each monitor that will be used to measure/track/record each parameter may include:

- Type of instrumentation used during normal operations;
  - Manufacturer and model number;
  - Monitor/instrument operational specifications (e.g., range, accuracy, and interferences);
  - Measurement frequency capabilities;
  - Operating temperature range of monitor, if monitor is *in-situ* type;
  - Description of the calibration procedures and frequency;
  - Description of the routine and preventive maintenance procedures and frequency;
- Description of monitor operation;
  - Parameter/pollutants being monitored for normal operations;
  - Monitoring locations, and an explanation why each location was chosen and why it results in representative samples/parameter measurements;
  - Measurement frequency capabilities as compared to the proposed parameter recording frequencies, including a brief description of how the monitor output will be used to assure compliance with the levels demonstrated during the performance test;
  - Description of the data acquisition and recording system for all operating parameters, including a description of how the data acquisition system calculates and records operating parameter levels consistent with the anticipated limitations that will be required based on the levels demonstrated during the performance test;
  - Description of the process to physically extract a sample if the monitor is extractive, including necessary sample conditioning systems (if applicable);
  - Evidence that the monitoring method will generate reliable data (e.g., performance data from a dry run of the system using non-TSCA-regulated waste);
  - Description of the system for triggering automatic feed cutoff, if applicable;
  - Contingency for monitor failure (e.g., install and calibrate second monitor); and
  - Description of any data processing that will be done such as, data reduction procedures, calculations, etc.

#### 4.2.9 Approval Application Section VII - Sampling and Analysis Procedures

A detailed discussion of the sampling and analysis methods to be used during normal operations should be included in this section of the approval application. When “standard methods” will be used, they may be referenced and included as an appendix. However, any deviations from standard procedures should be noted. Furthermore, when the standard method allows different procedural variations to be used, the applicant should be specific as to the procedures that will be followed.

**BE AWARE THAT CERTAIN CHEMICALS, SUCH AS PHTHALATES IN PLASTICS, CAN CAUSE INTERFERENCE IN ANALYSIS. ALSO, SILICONE CAN MAKE PCBs DIFFICULT TO EXTRACT AND EXTENDED EXTRACTION TIMES MAY BE REQUIRED**

A discussion of the sampling and analysis procedure should be provided and may include:

- A summary of the sampling and analytical procedures;



- This may overlap with the procedures discussed in the monitoring and sampling plan, in which case it may be referenced. For more information, see [section 4.2.7](#);
- Be sure to include any information regarding the sampling method that may be missed in the monitoring and sampling plan. For example, the applicant may have indicated they were taking composite samples from a waste pile after treatment. There are many ways to take composite samples; therefore, it is important that the compositing method is discussed in detail in this section;
- Summarize analytical procedures and any procedures used to prepare the sample, including the EPA method numbers and any deviations from the methods, the applicant's method numbers, and whether an on-site laboratory will be used;
- Indicate the sampling locations, and an explanation for why each location was chosen and results in representative samples/parameter measurements;
- Describe how the samples are stored, preserved, and recovered;
- Discuss how samples are transported and how custody is transferred;
- A description of the sampling and analytical equipment/apparatus used to take, transport, extract and analyze a sample;
  - Include the equipment manufacturer and model number;
  - Provide sampling and analytical equipment specifications, if applicable (e.g., range, accuracy, and interferences);
  - Describe how the sampling and analytical equipment is calibrated, standards used, and the frequency with which it is calibrated;
  - Describe any reagents used during sampling and analysis, and discuss how the reagents will be prepared and used;
  - Describe the routine and preventive maintenance procedures and frequency;
- A description of any data processing that will be done, such as data reduction procedures, data validation procedures, calculations, etc.

Specific details of some analytical procedures may be referenced (if a standard published procedure) or included as an appendix (if unpublished or if the publication is not readily available). If needed, include a description of when it is appropriate to analyze for PCBs as homologs or congeners.

[Appendices C](#) and [E](#) of this document provide guidance on monitoring, sampling, and analysis procedures of various matrices and list various sample methods.

#### ***4.2.10 Approval Application Section VIII - Data Recordkeeping and Reporting***

The approval application should explicitly state what data will be recorded (including units), how it will be recorded, how it will be handled by the applicable data system to calculate operating levels in the units/averaging periods that will be established as operating limits based on performance test data, and how the data records will be maintained. Include example calculations, units of measurement, and example record reporting forms and/or description of the electronic data recording system. Sections 761.180(b) and 761.180(c) establish the minimum data record requirements for disposers of PCB waste and incinerator facilities, respectively. Section 761.180(b) requires that each PCB disposal facility maintain annual records on the disposition of all PCBs and PCB Items and prepare and maintain an annual document log. The annual document log must be prepared by July 1 for the previous calendar year. The annual records must include all signed manifests and Certificates of Disposal that have been generated or received at the facility during the calendar year and all records of inspections and cleanups performed in accordance with § 761.65(c)(5). The annual records must be maintained at the facility for

at least three years after the facility is no longer used for the disposal of PCBs and PCB Items. The annual document log must include the information in § 761.180(b)(2). The annual report must briefly summarize the records and annual document log required to be maintained under § 761.180(b)(1) and (b)(2) and must consist of the information in § 761.180(b)(3). (EPA anticipates use of e-Manifest to maintain these documents, once relevant functionality becomes available.)

Section 761.180(c) requires additional records and monitoring for incineration facilities. The information specified in § 761.180(c) must be maintained for a period of five years from the date of collection. (EPA anticipates use of e-Manifest could satisfy the requirements in § 761.180(c), once relevant functionality becomes available.)

#### ***4.2.11 Approval Application Section IX - By-Product Waste Handling and Treatment/Disposal***

The approval application should identify any by-product waste (both PCB and non-PCB) or potential wastes that would need to be sampled/analyzed to determine if they would be considered waste, that will be generated (e.g., in-line filters for the PCB waste feed line, process water, or solid residues generated such as incinerator ash). The application should also discuss how waste that is generated will be handled/stored/disposed, including whether such waste is subject to state or federal regulations, e.g., RCRA.

#### ***4.2.12 Approval Application Section X - Inspection Procedures***

The approval application should identify the routine inspection procedures used to identify problems and malfunctions associated with the facility. Also, the frequency of inspections should be discussed.

Inspection procedures should be identified for items such as:

- Waste feed system;
- Destruction system;
- Waste feed cutoff system;
- Pollution control system;
- Process operation alarms;
- Storage areas;
- Secondary containment areas;
- Spill collection systems (e.g., portable booms); and
- Fire suppression equipment/system.

#### ***4.2.13 Approval Application Section XI - Spill Prevention, Control, and Countermeasures Plan***

Discuss the procedures at the facility that will be used to prevent PCB spills and how to respond to any PCB spills that occur. The regulations stated in 40 CFR part 112 can serve as an example for the spill prevention, control, and countermeasures (SPCC) plan; however, the plan in the approval application need not be in the format or in the detail specified in 40 CFR part 112.<sup>34</sup> Examples of procedures to include in the SPCC plan may include, but are not limited to:

- Secondary containment for any stored PCB wastes and PCB-contaminated by-products (secondary containment of two times the volume of the largest container/article or 25% of the

---

<sup>34</sup> When reading 40 CFR part 112, consider “Oil(s)” to mean “PCB(s)” whenever it appears.

total volume of PCB articles/containers, whichever is greater);

- Spill reporting and cleanup procedures;<sup>35</sup>
- Procedures for storage and transfer operations;
- Information on design elements and inspection procedures used to prevent spills and the planned response to spills, with responsible individuals identified; and
- Reporting requirements, cleanup procedures, and disposal methods for any contaminated residual materials.

#### **4.2.14 Approval Application Section XII - Safety Plan**

The approval application should present a description of a site-specific safety plan that will be initiated to protect workers and the general population from PCB exposure or other health hazards. A copy of the site-specific safety plan should be kept on-site where operations will occur.

The following information may be included in each site-specific safety plan:

- Scope of work (general description of the treatment process and any hazardous materials to be used);
- Project personnel, including roles, responsibilities and qualifications, name of on-site safety coordinator, and name(s) of any on-site cardiopulmonary resuscitation (CPR)/First-Aid certified person(s);
- Emergency contact information, including local authorities (e.g., local fire and police departments) and nearest medical facility that would accept patients contaminated with chemicals;
- Hazard identification (e.g., potential for reactions/fires) and control/mitigation measures;
- Procedures for handling of dangerous and pyrophoric chemicals;
- Required personal protective equipment (PPE);
- Names of all chemicals used at the facility along with approximate quantities and the corresponding safety data sheets (SDS);
- Provide any additional precautions that may be needed to ensure adverse reactions/spills do not occur overnight or during system down/idle times;
- Monitoring methods used such as smoke alarms;
- Discuss the automated fire suppression systems, if applicable;
  - Describe how the fire suppression system is compatible to the waste and treatment system (e.g., sodium fires require specialized equipment);
- Procedures for shutting off equipment in case of an emergency;
- Emergency action plan(s) specifying the following:
  - Contact information – project and property management, and the persons responsible for handling emergencies (with 24-hour a day contact in the event of an emergency), including both phone numbers and email addresses;
  - Plans for coordination with/notification to local emergency responders;
  - Evacuation plan(s);

**SPECIAL SAFETY CONSIDERATIONS  
SHOULD BE GIVEN TOWARD THE  
USE OR BUILDUP OF  
HAZARDOUS/REACTIVE  
COMPOUNDS, SUCH AS SODIUM,  
HYDROGEN, OR HYDROCHLORIC  
ACID**

<sup>35</sup> See 40 CFR 761.125 for more information.

- First aid location(s);
- Eye-wash station location(s);
- Fire extinguisher location(s);
- Location of SDS;
- Flammable storage area(s); and
- Smoking/non-smoking areas.

Locate the treatment operations/equipment at an adequate safety distance so that they will not present an unreasonable risk of injury to health or the environment. For example, a unit with the potential to cause a fire should maintain a minimum distance away from any storage area for flammable or combustible materials (e.g., flammable liquid storage tanks or drums) or any sensitive ecosystem if the treatment unit is operated outdoors. All necessary precautionary measures should be taken to ensure that operations follow the applicable safety and health standards, as required by federal, state and local laws, regulations and ordinances.

Note that, as a condition of the PCB approval, the applicant may be required to report any lost-time injury to the PCB coordinator in the appropriate EPA Regional office by the next business day. Typically, it is a good practice to also draft a report describing the accident and submit it to the ORCR Office Director at EPA Headquarters.

#### ***4.2.15 Approval Application Section XIII - Training Plan***

The approval application should present a description of the training program that will be initiated to assure workers are trained in items appropriate to their jobs. The training plan will ensure that personnel directly involved with operations are familiar with the requirements of the approval.

The following documents should be included in the training plan and made accessible to personnel:

- The operating approval;
- The operating approval application;
- The test approval request and associated test approval issued by EPA;
- The Site-Specific Safety Plan;
- The Spill Prevention, Control and Countermeasure Plan; and
- Sampling and analytical procedures.<sup>36</sup>

Personnel should be trained on the following items:

- The type of PCBs treated and the upper PCB concentration limits which may be treated, including the dangers PCBs present;
- The recordkeeping, notification and reporting requirements, and the location of records and retention times;
- Equipment operation and emergency shutdown procedures and standard operating procedures (all employees should sign and date a statement indicating the employee has read and understood SOPs);
- The handling and/or PCB waste disposal requirements as described in the approval for process waste, and other materials generated during operations;
- The handling of dangerous and pyrophoric chemicals (e.g., sodium or potassium);

---

<sup>36</sup> The sampling and analytical procedures should also be maintained in the laboratory conducting the analyses.

- The safety, operating, and maintenance procedures;
- The procedures for using, inspecting, repairing, and replacing emergency and monitoring equipment, with an emphasis on the fire suppression equipment;
- PCB Spill Cleanup Policy 40 CFR 761 subpart G;
- Sampling and analytical procedures (as needed); and
- The Spill Prevention, Control and Countermeasure Plan.

#### ***4.2.16 Approval Application Section XIV – Test Plan Summary***

This section of the approval application should briefly summarize the applicant’s plans for conducting a test; a separate detailed plan is required prior to conducting a test (see [section 5](#) of this document).

However, summary information that should be presented in this section includes:

- Tentative date (month/year) for the test;
- Tentative location for the test;
- Parameters to be tested;
- Planned duration of each run;
- Number of runs;
- Type and quantity of waste to be used in each run; and
- Expected/actual submittal date of the detailed test plan.

If possible, please display the major operating parameters to be tested in a table, organized by run. This provides a quick reference table that can also be used in the test plan.

#### ***4.2.17 Approval Application Section XV - Test Data or Engineering Performance Calculations***

The applicant should summarize any relevant data from R&D activities, previous tests using either TSCA regulated or non-TSCA regulated waste, or other relevant testing/data, and engineering calculations that support the ability of the system to comply with applicable PCB requirements. Detailed test results need not be presented in this section, but instead may be summarized and provided as an appendix or referenced if already on file with EPA.

#### ***4.2.18 Approval Application Section XVI - Other Permits and Approvals***

Provide a list of other regulatory requirements the treatment/disposal unit is, or will be, subject to and include brief discussions of the permits/approvals, that have been or will be obtained for the disposal unit. Also, identify the permitting agency and the person to contact for additional information (permit writer). Some regulations are self-implementing and, if applicable to the treatment unit, then they should also be mentioned in this section. Relevant approvals/permits/requirements include, but are not limited to:

- Prior or current PCB approvals issued by EPA (Region or Headquarters);
- State or local permits to operate;
- RCRA permits;
- Clean Air Act permits (e.g., Title V permits) or other requirements (e.g., hazardous waste combustion National Emission Standards for Hazardous Air Pollutants (NESHAP));
- National Pollutant Discharge Elimination System (NPDES) permits;
- Nuclear Regulatory Commission (NRC) permits;
- Department of Energy (DOE) permits; and

- Department of Transportation (DOT) permits and/or requirements.

#### **4.2.19 Approval Application Section XVII - Schedule of Events**

Provide a proposed schedule (month and year) for complying with the regulatory requirements associated with approval of the facility. Scheduled items to be addressed may include: beginning construction date and completion date, submittal of test plan, equipment shakedown period, initiation of test, submittal of test results, and initial operating date. A Gantt chart is a useful tool for displaying the proposed schedule of events.

#### **4.2.20 Approval Application Section XVIII - Quality Assurance Project Plan**

Each approval application should include a quality assurance project plan (QAPP) and the plan should be included in the application's appendix. An example template for a QAPP is provided in [Appendix D](#).<sup>37</sup> The QAPP should address all measurement (e.g., monitoring) parameters and data-generating activities (e.g., process monitors and controllers), not just chemical laboratory analysis. This plan should conform to the specifications established in "Guidance for Quality Assurance Project Plans, EPA QA/G-5" (U.S. EPA, 2002). Additional guidance in the preparation of a QAPP is available in "EPA Requirements for Quality Assurance Project Plans" (U.S. EPA, 2001). Note that every technology is different and may require different testing or monitoring. As such, some elements of a QAPP may not be applicable to all technologies, therefore, EPA may require some elements to be included in one QAPP but not another. Where the QAPP repeats information in other submitted documents, a reference to the applicable document and section is sufficient. If the applicant will be using their own on-site laboratory, SOPs for laboratory procedures should be included in the QAPP.

The purpose of the QAPP is to establish a specific program to: (a) help assure that the monitoring data meet specific quality objectives, and (b) routinely assess the quality of the monitoring data. Appropriate quality assurance (QA) is imperative. If the data (physical or chemical measurement) are of unknown quality, then the data are unacceptable and cannot be used to demonstrate that a facility is operating within approval requirements.

A QAPP should include the following content, as applicable:<sup>38</sup>

- *Distribution List*: includes a list of individuals and organizations who play a role in the development or implementation of the QAPP and will receive a copy of the approved QAPP.
- *Problem Definition/Background*: includes a statement of specific problem to be solved, decision to be made or outcome to be achieved; background information.
- *Quality Objectives and Criteria*: includes outputs from the systematic planning process (e.g., data quality objectives [DQOs]); measurement performance or acceptance criteria established (e.g., precision, bias, accuracy, representativeness, comparability, completeness, sensitivity). DQOs are defined using a systematic planning process that defines the quality objectives and the performance criteria. These relate the quality of the data needed to the established limits on the chance of making a decision error.
- *Special Training/Certification*: includes any specialized training certifications needed by personnel; plans for providing, documenting, and assuring this training.

---

<sup>37</sup> It is suggested to check with EPA approval writers in the appropriate region for additional details not included in this QAPP example.

<sup>38</sup> See the following document for more details: "Guidance for Quality Assurance Project Plans, EPA QA/G-5" (U.S. EPA, 2002).

- *Documentation and Records*: includes a list of records to be included in the data report package; list of any other project documents to be produced; information on the final disposition of records and documents, including location and retention schedule.
- *Sampling Process Design (Experimental Design)*: includes a description of the project's experimental design.
- *Sampling and Analytical Methods*: includes a description of sample/data collection procedures and analytical methods; list of equipment needed; identification of performance requirements; description of corrective actions to be taken if problems arise.
- *Sample Handling and Custody*: includes a description of sample handling and transfer requirements for ultimate disposal.
- *Quality Control (QC)*: includes a list of QC activities needed for sampling, analytical or measurement techniques, along with their frequency (e.g., blanks, spikes, calibration check samples, replicates, splits); description of control limits for each QC activity and corrective actions when these are exceeded; and identification of any applicable statistics to be used. Quantitative data quality indicators (DQIs) include accuracy, precision, and completeness. Qualitative DQIs include comparability and representativeness. Definitions of these DQIs are presented in the glossary at the beginning of this document.
- *Instrument/Equipment Testing, Inspection, and Maintenance*: includes a list of equipment and/or systems needing periodic maintenance, testing or inspection, and the schedule for such; description of how inspections and periodic preventive maintenance procedures will be performed and documented; discussion of how critical spare parts will be supplied and stocked; description of how re-inspections will be performed and effectiveness of corrective actions.
- *Instrument/Equipment Calibration and Frequency*: includes a list of all project tools, gauges, instruments, and other sampling, measuring, and test equipment which should be calibrated; description of calibration method and identification of any certified equipment and/or standards to be used; and details of how calibration records will be maintained and traceable to the instrument/equipment.
- *Inspection/Acceptance for Supplies and Consumables*: includes a list of project supplies and consumables that may directly or indirectly affect the quality of the results; the acceptance criteria for them; and identification of those responsible.
- *Non-direct Measurements*: includes identification of any existing data that will be obtained from non-measurement sources, such as literature files and historical databases; description of how you intend to use the data; your acceptance criteria and any limitations for using such data.
- *Data Management*: includes a description of the project data management process; description of or reference to the office's standard record-keeping procedures and document control, data storage, retrieval, and security systems; identification of data handling equipment and procedures to process, compile, and analyze project data; discussion of data handling procedures to detect and correct errors and loss during data processing; examples of any forms or checklists to be used; identification of any specific computer hardware/software performance requirements and how configuration acceptability will be determined; and description of how applicable information resource management (IRM) requirements will be satisfied.
- *Assessments and Response Actions*: includes a description of project assessments planned and a brief discussion of the information expected; approximate schedule for these assessments and their reports; for any self-assessments, identification of potential participants and their relationship within the project organization; for independent assessments, identification of the

organizations and person(s) that will conduct the assessments; and identification of how, when, and to whom the results of each assessment will be reported.

- *Reports to Management*: includes frequency and distribution of reports to inform management of the project's status; and identification of report preparer and recipients, as well as any specific actions or recommendations recipients are expected to make.

#### ***4.2.21 Approval Application Section XIX - Standard Operating Procedures***

Standard operating procedures (SOP) under this guidance refers to general procedures used by the facility when operating their PCB treatment system. SOPs should be a step-by-step guide for:

- starting up and shutting down the treatment system;
- maintaining automated control;
- mobile unit shutdown and decontamination of the unit at each site prior to moving to a new site, if applicable;
- switching to manual operation if automated controls fail;
- emergency shutdown if parameters are out of normal ranges or a leak is detected; and
- other SOPs that may be required.

A summary of the SOPs should be included in this section. Complete SOPs should be included as an appendix to the application and made available to facility operators. Applicants may submit a copy of the process operating manual to satisfy this requirement. SOPs should include sufficient information to replicate the process, but it is not necessary to include every minute detail, such as the use of specific equipment.

Divergence from the SOP during tests or commercial runs should be documented and permanent modifications should be submitted to EPA. For convenience of use, lab procedures should be separate from system operational procedures.

Instructions on SOPs should be part of the applicant's training plan. Each employee should sign and date a statement indicating that the employee has read and understood the SOPs. These signed statements should be kept on-site.

#### ***4.2.22 Approval Application Section XX - Closure Plan***

The TSCA provisions promulgated in § 761.65 require owners and operators of commercial storage facilities to develop a written closure plan identifying steps that shall be taken to close facilities in a manner that eliminates the potential for post-closure releases of PCBs that may present an unreasonable risk of injury to health or the environment. Generally, applicants for PCB treatment/disposal approvals are required to develop a written closure plan. In cases where EPA has determined closure financial assurance is necessary, the Agency recommends applicants look to the PCB commercial storage closure financial assurance provisions at § 761.65(g) to determine what types of mechanisms and specifications are generally acceptable. A closure plan should include provisions for a worst-case scenario closure that could be carried out by a third party.

For stationary facilities, the closure plan should address permanent closure of the facility. For mobile treatment units, the closure plan should address permanent closure of the treatment unit. Mobile unit shutdown at each site prior to moving to a new site is not considered closure, and would be covered in the application as a standard operating procedure (see [section 4.2.21](#)). An acceptable closure plan for



permanent closure should include the following:

- A description of how the PCB storage and handling areas of the facility will be closed in a manner that eliminates the potential for post-closure releases of PCBs into the environment;
- An estimate of the maximum inventory of PCB wastes that could be handled at one time at the facility over its active life and a detailed description of the methods or arrangements to be used during closure for removing, transporting, storing, and disposing of the facility's inventory of PCB waste, including identification of any off-site facilities that will be used (see [section 4.3](#) for a discussion regarding financial assurance of on-site vs. off-site disposal);
- A detailed description of the steps needed to dispose of PCB waste and decontaminate contaminated system components, equipment, structures, and soils during closure in accordance with 40 CFR 761 subpart D;
- A detailed description of other activities necessary during the closure period to ensure that any post-closure releases of PCBs will not present an unreasonable risk of injury to health or the environment;
- A schedule for closure of each area of the facility where PCB waste is stored or handled, including the total time required to close each area of PCB waste storage or handling and the time required for any intervening closure activities;
- A financial assurance statement (see [section 4.3](#) for a more information); and
- The expected year of closure of disposal units and PCB waste storage areas, if a trust fund is chosen as the financial mechanism.

### **4.3 Financial Assurance Documentation**

Prior to issuance of the operating approval, the applicant may be required to submit documentation of financial assurance for closure and third-party liability of the PCB disposal facility. Further, the Agency has discretion to require financial assurance for incineration and alternative disposal methods as a condition of the approval. In general, the Agency believes the requirement to obtain financial assurance for closure and for third party liability is a necessary provision to ensure the operation will not present an unreasonable risk of injury to health or the environment. In addition to reviewing the guidance relating to cost estimates and acceptable financial assurance mechanisms in this section, EPA encourages early consultation with the PCB coordinator prior to obtaining a mechanism to ensure compliance.

#### **4.3.1 Closure Financial Assurance**

If EPA determines that there is a need for financial assurance for closure of the facility, EPA recommends applicants use the regulations for financial assurance for closure of PCB commercial storage facilities as a guide for closure provisions and financial assurance mechanisms that are generally acceptable. These regulations are located at §§ 761.65(d)-(g) and include provisions for acceptable closure plans, cost estimates, and financial assurance instruments.

As a practical matter, closure financial assurance typically requires a written closure plan. The execution of the closure plan forms the basis of the cost estimate which in turn determines the amount of financial assurance needed for closure. In the event EPA determines that closure financial assurance is necessary, the PCB commercial storage regulations governing acceptable closure plans at § 761.65(e) would be appropriate. The provisions promulgated in § 761.65(e) require owners and operators to develop a written closure plan identifying steps that shall be taken to close facilities that eliminate the potential for

post-closure releases of PCBs that may present an unreasonable risk of injury to health or the environment.

Generally, the Agency will find a closure cost estimate prepared in accordance with § 761.65(f) to be acceptable. The provisions in § 761.65(f) require that the closure cost estimate be a detailed estimate, in current dollars, of the cost of the owner operator hiring a third party to close the facility in accordance with its approved closure plan. The closure cost estimate shall be in writing and be certified by the person preparing it using the following certification, as provided in § 761.3:

*“Under civil and criminal penalties of law for the making or submission of false or fraudulent statements or representations (18 U.S.C. 1001 and 15 U.S.C. 2615), I certify that the information contained in or accompanying this document is true, accurate, and complete. As to the identified section(s) of this document for which I cannot personally verify truth and accuracy, I certify as the company official having supervisory responsibility for the persons who, acting under my direct instructions, made the verification that this information is true, accurate, and complete.”*

Note that when calculating the closure cost, the Agency will likely require in the approval that the owner or operator include in the estimate the current market costs for off-site commercial disposal of the facility's maximum estimated inventory of PCB wastes, except that on-site disposal costs may be used if on-site disposal capacity will exist at the facility at all times over the life of the PCB storage facility.<sup>39</sup> If the on-site disposal exception is allowed and the facility is able to dispose of their maximum inventory on-site, they must still consider the cost to hire a third party to use the on-site disposal.<sup>40</sup> Additionally, it is EPA's position that the availability of a facility's on-site disposal process that uses a proprietary, mobile, or technologically complex unit is not guaranteed, and therefore generally should not be used as an input for the closure cost estimate.<sup>41</sup> Closure costs in the case of a proprietary, mobile, or technologically complex unit must then include off-site disposal of the facility's maximum inventory by a third party.

In cases where EPA has determined closure financial assurance is necessary, the Agency recommends applicants look to the PCB commercial storage closure financial assurance provisions at § 761.65(g) to determine what types of mechanisms and specifications are generally acceptable. These provisions reference subpart H of the RCRA regulations at §§ 264.143 and 151. In general, EPA believes these instruments are appropriate for demonstrating closure financial assurance for operators of PCB incinerators and alternative disposal methods and their specifications (including non-cancellation clauses and irrevocability) are necessary provisions. However, not all provisions will necessarily be appropriate in the case of approvals to operate PCB alternative disposal methods under TSCA. It is recommended to consult your PCB approval writer early regarding a facility's specific financial assurance requirements.

---

<sup>39</sup> See 40 CFR 761.65(f)(1)(iii).

<sup>40</sup> See 40 CFR 761.65(f)(1)(ii).

<sup>41</sup> Memorandum: Policy Regarding Use of On-site Disposal Methods When Calculating Financial Assurance Closure Cost Estimates. Signed by Maria J. Doa. OPPT. May 1, 2007.

### ***4.3.2 Third-Party Liability Financial Assurance***

In addition, as part of providing adequate financial assurance for an alternative disposal method approval, the owner or operator may be required to provide financial assurance for the compensation of others for bodily injury and property damage caused by accidents arising from facility operations. The provisions governing third party liability that EPA typically would find acceptable for alternative disposal method approvals can be found at § 264.147 and wording for the corresponding mechanisms can be found at § 264.151. Consultation with the PCB approval writer may be necessary to determine if financial assurance for third-party liability is needed.

### ***4.3.3 Maintenance of Financial Assurance***

At the time of application, the owner or operator should address future maintenance of the closure cost estimate and financial assurance mechanisms. In the case of an incinerator or alternative disposal method approval, EPA believes adjusting the cost estimate for inflation would be necessary to ensure the value of the financial assurance remains equal to the cost of closing the facility and would generally find a cost estimate adjusted for inflation in the manner described in § 761.65(f) to be acceptable. Section 761.65(f) requires that during the active life of the facility, the owner or operator shall annually update the closure cost estimate for inflation 60 days prior to the anniversary date of the establishment of the financial instruments used to demonstrate closure financial responsibility. In cases where a financial test or corporate guarantee is used the closure cost estimate shall be updated for inflation within 30 days of the owner/operator's fiscal year. The provisions for acceptable inflation adjustments at § 761.65(f)(2) state that the inflation factor used is to be derived from the most recent Implicit Price Deflator for the Gross National Product published by the U.S. Department of Commerce. However, EPA recognizes that since those regulations were written, the Department of Commerce has largely shifted to using the Gross Domestic Product. Therefore, EPA typically would accept inflation adjustments using either a deflator based on the Gross National Product or the Gross Domestic Product, as long as the chosen deflator is consistently used.

The requirements for each financial assurance mechanism, as described in §§ 264.143, 147, and 151, include mechanism maintenance which EPA generally finds protective for PCB disposal approvals. In general, maintenance requires the owner or operator to ensure that the face value of financial assurance mechanisms continues to be a sufficient amount to cover closure cost estimates following inflation adjustments. Use of financial test or corporate guarantee mechanisms require annual resubmission of the items demonstrating a firm's ability to pass the financial test and acceptance by EPA.

### ***4.3.4 Release of Financial Assurance Obligation***

Generally, EPA will require the owner/operator to maintain financial assurance until the Agency receives certifications from the owner or operator and an independent registered professional engineer that final closure has been completed in accordance with the approved closure plan. After receiving such certifications, the Regional Administrator or the Director of ORCR will notify the owner or operator in writing that the owner or operator is no longer required to maintain financial assurance, unless there is reason to believe that final closure has not been completed in accordance with the approved closure plan. In such instances, the Regional Administrator or the Director of ORCR will usually provide the owner or operator with a detailed written statement identifying inconsistencies between closure and the closure plan. .

#### ***4.3.5 Transfer of Ownership or Operational Control***

In cases where EPA determined financial assurance was necessary, prior to transfer in ownership or operational control of the disposal facility, the transferee will typically also be required to establish financial assurance as described above. Generally, EPA will approve the transfer under the conditions laid out in § 761.65(j). The conditions at § 761.65(j) ensure adequate financial assurance remains in place. Specifically, the date of transfer usually should be the date the Regional Administrator or the Director of ORCR provides written approval of transfer so that there will be no lapse in financial assurance for the transferred facility. The Regional Administrator or the Director of ORCR will normally approve the transfer, if the transferee has established financial assurance effective as of the date of final approval of the transfer and any deficiencies (e.g., technical operations, closure plans, cost estimates) that EPA has identified in the application have been resolved. EPA will usually provide a final written decision within 90 days of receipt of the financial assurance documentation.

## SECTION 5 TEST PLANS

This section presents the suggested format for a test plan and discusses the information that should be provided.<sup>42</sup> The test plan should be submitted for approval to the delegated EPA official (see [section 2.2](#) for a more detailed discussion on EPA delegation of authority). Contact EPA personnel to receive specific instructions for submitting CBI material (see [section 4.1.5](#) for more information). Following receipt of the test plan, EPA will either approve, require additions or modifications to, or disapprove the test plan. If the test plan is disapproved, EPA will notify the applicant and provide the rationale for the disapproval. A new test plan may be submitted that satisfies the requirements indicated by EPA's comments. Both an application (see [section 4](#)) and a test plan are required before EPA can issue a test approval. The test cannot be conducted until a test approval has been issued by EPA. While the electronic submission of files is preferred, EPA will occasionally request paper copies of the test report. The applicant is encouraged to communicate with EPA early and often during this process to ensure that the approval process is as timely and agreeable as possible.

### 5.1 General

A test plan is a detailed plan for conducting and monitoring the test. Tests conducted under § 761.60(e) encompass a variety of technologies such as those that destroy PCBs (e.g., chemical dechlorination) as well as those that facilitate treatment of PCB waste (e.g., PCBs are captured by carbon filtration which are later disposed at a different facility). EPA recommends including the same types of information in test plans for both incineration and alternative to incineration methods to treat/dispose of PCB waste. The minimum contents required in the test plan, as identified in § 761.70(d)(2)(ii), are as follows:

- Time, date, and location of the test;
- Quantity and type of PCBs and PCB Items to be incinerated or processed during the test;
- Parameters to be monitored and location of sampling points;
- Sampling frequencies, methods, and schedules for sample analyses; and
- Name, address, and qualifications of persons who will review analytical results and other pertinent data, and who will perform a technical evaluation of the effectiveness of the test.

If the company submitted the test plan and/or operating approval to EPA but needs to make a major modification prior to testing, the company should submit revised applications to EPA as soon as possible, but at least 14 days prior to the test or as specified in the test plan approval. Major modifications are modifications to the test plan that would have an impact to the no unreasonable risk determination (e.g., change in feed rate, PCB concentration, or residence time in the reactor). Minor modifications are modifications to the test plan that would have no impact to the no unreasonable risk determination (e.g., change in disposal of process wastes, or if feed will be pumped from 55-gallon drums during the test, in lieu of using a bulk feed storage tank that will be used during normal operation). Minor modifications may only warrant EPA notification prior to implementing the testing change, and shall be documented. Such documentation should be submitted to EPA either prior to the test, or with the test report, depending on when such changes were deemed necessary (e.g., before or after EPA has approved the test plan) or depending on how significant the change is. Also, if events require that the plan be significantly modified during the test, then the approval writer should be contacted immediately to discuss the implications of any modifications.

---

<sup>42</sup> As a reminder, trial burns and demonstration tests are referred to collectively as tests.

Throughout the test, an “event log” should be maintained. This log should be submitted as part of the test report. Note that, in most cases, the test approval will specify what types of changes need prior approval from EPA, and the procedures the company should follow when such changes are necessary.

The remainder of this section provides the suggested format of the test plan and its contents. [Appendix C](#) summarizes and discusses appropriate methods for monitoring and sampling process feed streams (e.g., PCB waste prior to treatment), treatment process effluents, and emissions. Also, [Appendix E](#) provides a list of methods for cleanup, extraction, and determination. As discussed in [section 4](#), the information provided in this section may not be comprehensive and applicants should provide additional information when appropriate.

EPA may provide public notice and comment opportunities on fixed-site disposal test plans. Draft test approvals for fixed-site disposal activities may be posted on EPA’s website during the public comment period, along with additional information about the applicant and the proposed test. During the public notice period, all documents associated with the test approval should be made available to the local community. The public comment period usually lasts thirty (30) days and comments are accepted by email and mail. Additionally, a public participation meeting is often held in the community nearest the facility. This meeting serves to educate the public on the proposed test and provide a listening session to hear community concerns. Public comments will be reviewed and considered prior to making the final decision on issuance of the test approval (also see [section 8](#)).

### ***5.1.1 The Purpose of the Test and General Approach***

The purpose of a test is twofold:

1. To determine whether the proposed unit can meet the applicable standards and operate in a manner that poses no unreasonable risk of injury to health or the environment, and
2. To determine at what operating conditions that a compliant level of performance can be maintained over time during day-to-day operations. Those successful operating conditions are generally set as requirements in the approval.

Thus, it is important for the applicant to understand the relationship between the test and the operating parameter values that will ultimately be set in their approval, and plan accordingly to achieve a set of approval conditions that will be workable for the applicant’s planned day-to-day operation. The applicant should determine which parameters will be set as maximum levels, which will be set as minimum levels, and which will be set as a range (i.e., both maximum and minimum). The applicant also should determine which, if any, parameters will be set based on design specifications rather than the test. The applicant should consider the format of the operating conditions they will have in their operating approval, e.g., whether conditions will be set as absolute levels or with averaging timeframes. Furthermore, the applicant should factor in safety, such as reducing the likelihood of a fire, explosion, or exposure to hazardous substances.

Since the values of most key operating parameters will be set directly from the test, it is advisable for applicants to anticipate the outer edges of their anticipated operating envelope or worst-case scenarios, for example, the highest anticipated concentration of PCBs in the incoming feed, and design the test to achieve those approval conditions. Generally, this entails designating levels of test conditions that are slightly higher for conditions set as maximums and slightly lower for conditions set as minimums, to

allow room for fluctuation.<sup>43</sup>

**A GOOD TEST DESIGN SUPPORTS SMOOTH OPERATIONS AND WORKABLE APPROVAL CONDITIONS, AND MINIMIZES THE NEED FOR MODIFICATIONS OF THE APPROVAL**

Recommended steps for applicants to design test and operating parameters consist of the following:

- Identify key operating parameters that affect the performance of the unit;
- Determine desired approval levels for those parameters, including whether each is a maximum, minimum, or range;
- Propose a method for setting each parameter (e.g., based on demonstrated test conditions or manufacturer’s specifications);
- For each parameter, develop proposed test conditions that are likely to achieve compliance as well as achieve a set of approval operating conditions that support the anticipated operation of the unit;
- Confer on the design with approval writer; and
- Incorporate the results of this planning into the approval application and test plan.

## 5.2 Contents of a Test Plan

Table 9 presents a suggested format for a test plan. Suggested contents of the plan are discussed in the following subsections. Table B-2 of [Appendix B](#) provides a checklist to aid the applicant in determining whether this information has been included in the test plan. This checklist is not required and does not need to be submitted to EPA.

In instances where the applicant is submitting a revised test plan based on comments received from EPA or proposed changes to a previously submitted plan, the applicant should summarize such changes/revisions in [section 5.2.1](#), and if practicable, a redline/strikeout “compare” version that highlights the revisions should be provided.<sup>44</sup> The applicant is also encouraged to provide EPA with a standalone response to comments document that briefly explains/summarizes how each comment was addressed. This may facilitate EPA’s review of the revised plan.

In instances where significant deficiencies have been identified by EPA, or where the applicant is unclear as to how to address specific deficiencies, the applicant may find it useful to request a meeting or teleconference with the approval writer to best assure the revisions adequately address the comments received. EPA may deny the application if the deficiencies are not addressed within a reasonable period of time.

All test plans should be accompanied by a transmittal letter, which summarizes the request for approval to conduct a test and mentions relevant history of the request. If the test plan is being submitted in conjunction with an operating approval renewal application, this should be briefly discussed in the transmittal letter. In this circumstance, the updated plan should summarize how/whether this plan differs

---

<sup>43</sup> See tables 10 and 11 for examples.

<sup>44</sup> In instances where significant revisions or rewrites have been made, a redline/strikeout compare version may not be practicable/useful.

from their previously submitted/approved plan. A suggested cover page format for the test plan is shown in Figure 6. If a paper copy is requested by EPA and if the plan will be bound in multiple volumes, the applicant should number each volume in order in the upper right-hand corner of the cover (“Volume m of n”). The cover of each volume should also have all information shown in Figure 6.

**Table 9. Suggested Format for a Test Plan**

<b>Section No.</b>	<b>Section Title</b>
	Test Plan Cover
	Table of Contents
I	Summary
II	Project Organization
III	Treatment Process and Facility Information
IV	Operating Parameters
V	Monitoring and Sampling Plan
VI	Monitoring Procedures
VII	Sampling and Analysis Procedures
VIII	Emergency Procedures
IX	Test Data Reporting
X	Miscellaneous Tests
XI	Waste Handling and Disposal
XII	Test Schedule
	Quality Assurance Project Plan (addenda to approval application
XIII	QAPP)
	Standard Operating Procedures (addenda to approval application
XIV	SOP)
	Appendices

### ***5.2.1 Test Plan Section I - Summary***

The summary should indicate when, where, and by whom the test will be conducted. A brief background discussion about the treatment/disposal device to be tested should also be provided (e.g., treatment unit description, intended waste feeds, summary of previous tests or operations). Summarize any significant differences in the operation of the treatment unit for the test run relative to day-to-day operations. If there are any previous test plan submissions or revisions requested by EPA, briefly discuss any significant changes made.



TEST PLAN, VERSION #X (IF APPLICABLE)<sup>45</sup>

PCB TREATMENT/DISPOSAL UNIT

*[Type and location of unit]*

*[Name and location of company headquarters if different from above]*

Operating Approval Application Submission Date/Anticipated Date: *[date]*

Test Plan Submission Date: *[date]*

Proposed Test Dates: *[dates]*

Submitted by:

*[Company name and address]*

*[Principal manager  
and phone number]*

Submitted to:

Director, Office of Resource Conservation and Recovery

Office of Land and Emergency Management

U.S. Environmental Protection Agency

1200 Pennsylvania Avenue, NW

Mail Code 5303P

Washington, DC 20460

[ORCRPCBs@epa.gov](mailto:ORCRPCBs@epa.gov)

OR

If submitted to an EPA Regional office, provide the applicable Region's address listed at [www.epa.gov/pcbs/program-contacts](http://www.epa.gov/pcbs/program-contacts).

**Figure 6. Test Plan Cover Page Example.**

<sup>45</sup> If the document is revised and resubmitted to EPA, the applicant should clearly indicate on the cover that the report has been updated (e.g., version 2).

### ***5.2.2 Test Plan Section II - Project Organization***

An organizational chart and narrative description to identify the key personnel for the project should be provided. Identify personnel who have overall responsibility for conducting the test and their relationship to key personnel having overall authority for the operating approval (see [section 4.2.4](#)). This section should specify if responsibilities for certain activities are being contracted out, and, if so, to whom. Key areas of responsibility that should be identified include:

- Facilities manager;
- Principal manager;
- Test coordinator;
- Operations manager;
- Sampling crew chief;
- Monitoring systems operator;
- Analytical manager and key analyst;
- Quality assurance officer; and
- Safety officer.

Qualifications and formal certifications of the key company/contractor personnel who will be operating the system and conducting the sampling, monitoring, and analyses are to be provided with the test plan.

### ***5.2.3 Test Plan Section III - Treatment Process and Facility Information***

This section should provide a general overview of the treatment/disposal process, including a description and a detailed engineering drawing. Explain the provisions established for storage of the wastes prior to and during the test if different from the normal procedures identified in the approval application. This explanation should include a description of the storage facility and any permits that are in place or will need to be in place for use of the storage facility. Detailed information about the process and facility, including health and safety plans, employee training schedules, and recordkeeping, should be in the approval application and may be referenced. An explanation of the PCB waste and/or surrogate material to be used in the test should also be discussed.

### ***5.2.4 Test Plan Section IV - Operating Parameters***

This section presents the operating parameters to be maintained, monitored, and recorded during the test. The proposed parameters and their operating values/ranges should be carefully considered, as they will inform allowable operating parameter values/ranges needed to meet DRE and other standards<sup>46</sup> and, depending on the test results, may be included as limits in the operating approval.<sup>47</sup> If the test plan is submitted in support of a renewal request for operation, this section should highlight how the proposed parameter values differ from those specified in the existing/expiring operating approval. Information that should be presented in the test plan includes:

- Detailed plan for treatment unit operations during the test;
- Process operating parameters (e.g., temperature, pressure) for the treatment unit and associated pollution control devices, anticipated operating ranges/levels of these parameters, frequency of measuring/recording these parameters during the test and day-to-day operations, and the proposed method by which these measurements/recordings will be used to calculate enforceable operational limits;

---

<sup>46</sup> See [section 4.1.2](#) for other standards.

<sup>47</sup> See [section 5.1.1](#) for more information on the purpose of a test.

- Anticipated emissions and/or effluent levels;
- Quantity of PCBs or PCB Items to be fed as waste during the test (e.g., waste feed quantities, concentrations, and feed rate) and a description of the matrix that the PCBs are in (e.g., sediment, oil); and
- Identification of the Aroclor in waste.

A detailed schedule of events that explains the operating parameters that will be maintained during the start-up, operation, and shutdown phases of the test should be included. Sampling times and locations should be highlighted in the monitoring and sampling, discussed in [section 5.2.5](#).

The process operating conditions and anticipated emissions can be summarized in a tabular format. Tables 10 and 11 provide example summaries of test parameters for an incineration system and dechlorination system, respectively. Note that control limits (i.e., acceptable ranges) would be listed in the operating approval, and are based on demonstration of successful treatment at the anticipated levels.

Operating limits stated in the operating approval for both thermal and non-thermal systems are typically based on the results of the demonstration test. The applicant should carefully plan their test such that DRE and other standards<sup>48</sup> are met and that the test operating conditions lead to a set of approval conditions that are workable for their anticipated day-to-day operations.<sup>49</sup> Exceeding the operating limits stated in the operating approval may result in a violation, suspension, or termination of the operating approval.

---

<sup>48</sup> See [section 4.1.2](#) for other standards.

<sup>49</sup> See discussion in [section 5.1.1](#) for more information on the purpose of a test.

**Table 10. Example Summary of Test Parameters for an Incinerator <sup>1,2</sup>**

Parameter	Test Plan Proposed Value	Demonstrated Value <sup>3</sup>	Operating Approval Control Limits <sup>4</sup>
<u>Fuel/Waste Feed</u>			
Waste feed rate (kg/hr)	100	99.7	85 to 115
PCB concentration in feed (mg/kg)	3,500	3,509	< 3,500
Total chlorine in feed (mg/kg)	2,500	2,550	< 2,500
PCB feed rate (kg/hr)	0.35	0.348	0.30 to 0.40
Chlorine feed rate (kg/hr)	0.25	0.254	0.21 to 0.29
Auxiliary fuel feed rate (kg/hr)	15	15.1	NA
Total thermal duty (10 <sup>6</sup> Btu/hr)	4.5	4.55	< 5.0
<u>Combustion Conditions</u>			
Combustion air flow rate (acm/min)	60	61.1	< 65
Residence time (second)	2.2	2.18	> 2.2
Destruction temperature (°C)	1,250	1,271	1,150 to 1,350
Combustion gas O <sub>2</sub> (%)	5	5.05	> 5
Combustion gas CO <sub>2</sub> (%)	12	12.3	NA
Combustion gas CO (ppm)	20	19.2	< 100
<u>Pollution Control</u>			
Scrubber water flow (gpm)	100	97	> 85
Scrubber water (pH)	8.5	8.45	8.0 to 10.0
Venturi water flow (gpm)	75	78	60 to 100
Venturi pressure drop (in H <sub>2</sub> O)	25	27	> 20

<sup>1</sup> DISCLAIMER: This table is only an example and may not capture every relevant parameter, nor is every parameter listed in the table relevant to all technologies. Furthermore, applicants are not required to use this table.

<sup>2</sup> NA means not applicable.

<sup>3</sup> These values are measured or calculated after the test.

<sup>4</sup> Desired values before the test; values can be revised in the test report after the results have been obtained.

**Table 11. Example Summary of Test Parameters for a Batch Chemical Dechlorination Process <sup>1</sup>**

Parameter	Test Plan Proposed Value	Demonstrated Value <sup>2</sup>	Operating Approval Control Limit <sup>3</sup>
<u>Waste Feed</u>			
Batch Weight (kg/batch)	1,000	1,022	850 to 1,100
Batch Weight (gallons/batch)	275	273	250 to 300
PCB concentration in feed (mg/kg)	5,000	5,015	< 5,000
Total chlorine in feed (mg/kg)	3,500	3,512	< 3,500
PCB feed rate (kg/batch)	5	5.05	4.25 to 5.5
Chlorine feed rate (kg/batch)	3.5	3.51	3.0 to 3.9
<u>Operating Conditions</u>			
Batch residence time (hours)	2	2	> 2
Reactor temperature (°C)	40	41.3	35 to 45
Reactor pressure (millimeter of Mercury [mm Hg])	800	800	760 to 880

<sup>1</sup> DISCLAIMER: This table is only an example and may not capture every relevant parameter, nor is every parameter listed in the table relevant to all technologies. Furthermore, applicants are not required to use this table.

<sup>2</sup> These values are measured or calculated after the test.

<sup>3</sup> Desired values before the test; values can be revised in the test report after the results have been obtained.

This section should identify the waste feed that will be used during the test. Indicate the waste type, physical state, heat content (if applicable), and composition of the waste feed including the anticipated PCB concentration. Identify the total quantity of waste feed to be used during the test, and explain how it compares to the waste that will be processed during routine operation (e.g., the same, worst-case condition, mixture of anticipated wastes). Waste feed used in the test should be as similar as possible to the waste feed expected during operation. In situations where the applicant has exhausted all possible sources of suitable PCB waste, EPA will consider use of PCB surrogates, such as 1,2-dichlorobenzene, on a case-by-case basis.

### **5.2.5 Test Plan Section V - Monitoring and Sampling Plan**

This section presents the monitoring and sampling plan for the test. The plan should be detailed and specific to the proposed test to monitor process operation and verify that the PCB treatment/disposal achieves the level of performance equivalent to disposal in a § 761.70 incinerator or a § 761.71 high efficiency boiler and will not present an unreasonable risk of injury to health or the environment, as required under § 761.60(e). The plan should address all monitoring and sampling activities that will be conducted during the test and identify any monitoring or sampling activities that will not be conducted during normal operations. Likewise, any monitoring or sampling activities that will be conducted during normal operations that will not be conducted during the test also should be identified and justified in the test plan. Monitoring and sampling during normal operations should be discussed in detail in the application (see [section 4.2.7](#)). Monitoring and sampling during the test should replicate that of normal operations while the conditions of the test should be worst-case or most challenging relative to normal

operations.<sup>50</sup> A tabular format, with narrative explanation, as necessary, can be used to summarize the monitoring and sampling plan.

The objective of the monitoring and sampling plan should be to obtain results that are representative of the conditions at which the unit is operating. In cases where test samples may not be representative of the conditions at which the unit is operating, a worst-case result should be obtained (i.e., sample when the process is least likely to achieve the required treatment standards). In cases where problems can be anticipated (e.g., instrument failure), contingencies should be included in the monitoring and sampling plan.

Note that information in this section may overlap with information discussed in subsequent sections (i.e., monitoring procedures and sampling procedures, [section 5.2.6](#) and [section 5.2.7](#), respectively). This section is intended to discuss what methods will be used and where/how each will be applied in the treatment process. Discussion of the method itself and how each method is conducted is found in the subsequent sections. There is some overlap between these sections and the applicant may combine the monitoring and sampling plan and methods into one section, but be sure to review and include applicable information discussed in all three sections within this guidance (sections [5.2.5](#), [5.2.6](#), and [5.2.7](#)). Remember that there are some subtleties between each section, for example, measurement frequency could refer to the frequency used during normal operation, during the demonstration test, or the measurement frequency capabilities of the instrument; all three may be different. Furthermore, the recording frequency may differ from the measurement frequency.

The monitoring and sampling plan should include the following elements:

- A description of what is being sampled or monitored (including sampling location). This description should be organized by discrete sampling/monitoring activities (e.g., stack emissions, combustion chamber operating parameters, air pollution control device operating parameters, liquid waste, ash, product);
- The number of test runs, the planned duration of each run, quantity of PCB material to be processed during each run, and overall planned schedule for the entire test for all test conditions. Generally, a minimum of three tests are conducted for each test scenario;
- The objective of the sampling or monitoring for each unit (e.g., collect a “representative” sample; monitor and record combustion zone temperature; establish air pollution control device operating limits; follow an EPA test protocol; or collect a “worst-case” sample);
- The parameters to be tested. List the substance or property being measured, operating parameters, and media;
- The sample analysis method to be used. List the cleanup, extraction, and analytical methods to be used; detailed description of the methods may be presented in this section or an appendix, or a standard protocol may be referenced;
- The sampling or monitoring methodology/approach/criteria for each operating parameter. This may reference a standard protocol (e.g., EPA Reference Method 3, 40 CFR 60).<sup>51</sup> The frequency (e.g., every 15 minutes), size (e.g., 100 grams), timing (e.g., one hour after reaching steady-state conditions), number of replicates (e.g., 10 percent of the samples or 2 samples, whichever is greater, collected in triplicate), number of surrogate-spiked samples, and total number of samples

---

<sup>50</sup> The test is typically designed to be more challenging in order to receive desired operating approval conditions. See [section 5.1.1](#) for more information.

<sup>51</sup> See [Appendix C](#) for more information regarding EPA methods.

should be listed for each sample type. The sample size usually is dictated either by the amount of sample required to detect the analyte or by convenience (e.g., 1 liter for water);

- A justification may be required if the frequency of measurement/recording times are longer than typical industry standards at the time the application is received by EPA or if the measurement frequency is longer than what EPA believes is needed to prevent an unreasonable risk of injury to health or the environment;
- A calibration test protocol for sampling/monitoring devices to be used during the test, including acceptable margins of error and frequency of calibration;
  - Before the test, the facility should certify that its continuous emissions monitors such as oxygen, carbon monoxide, and carbon dioxide, have passed zero drift and span drift tests. EPA may choose to provide an audit cylinder for one or more of these monitors for a performance demonstration during the test;
- An estimate of sample representativeness. This may be based on data (e.g., historical data on replicates) or scientific/engineering judgment (e.g., a sample from an actively mixed feed tank might be characterized as representative);
- Contingencies for action if samples cannot be collected according to the plan (e.g., alternative sampling sites or times, an entirely new sampling plan, or repeat tests); and
- Discussion of safety considerations that prevent the risk of injury to the workers and the local community (e.g., integrity measurements, pressure control measures, measuring of the buildup of hazardous constituents, etc.).

The parameters that typically should be included in the monitoring and sampling plan for an incinerator or alternative method of disposal are discussed in the following subsections.

#### ***5.2.5.1 Pollutants and Parameters to be Monitored/Sampled during Tests for Incinerators or Alternative Thermal Destruction Technologies***

40 CFR 761.70 provides the minimum monitoring and recording requirements for normal incinerator operation, which apply when the unit is tested to demonstrate compliance with the applicable requirements and establish operating limits. These minimum parameters include the following:

- Rate and quantity of waste feed at no longer than 15-minute intervals;
- Reactor/combustion temperature measured on a continuous basis;
- Concentrations of O<sub>2</sub> and CO on a continuous basis, and CO<sub>2</sub> on a periodic basis; and
- Concentrations of NO<sub>x</sub>, HCl, residual Cl, PCBs, and total particulate matter.

In addition to those required by § 761.70, the applicant should propose any additional monitoring and sampling parameters that are necessary to ensure the operation of the PCB treatment/disposal unit does not present an unreasonable risk of injury to health or the environment and, for an applicant for an alternative technology, to verify that PCB destruction is equivalent to disposal by incineration.<sup>52</sup> The approval writer may determine it necessary for the facility to monitor/sample more parameters during the test (and subsequently during normal operations) to assure compliance with PCB regulatory requirements and/or assure operation of the incinerator does not present an unreasonable risk of injury to health or the environment. EPA may find it necessary to include limitations for these operating parameters in the operating approval based on the levels demonstrated during the test. Necessary (additional) parameters will vary based on the design of the treatment/disposal unit and associated pollution control systems, as applicable. Example additional operating parameters include, but may not

---

<sup>52</sup> 40 CFR 761.70(d)(4)(ii), 60(e)

be limited to:

- PCB content of the waste feed to calculate the Destruction and Removal Efficiency (DRE);
- Polychlorinated Dibenzo-p-dioxin (PCDD) and Polychlorinated Dibenzofuran (PCDF) (tetra-through octachloro homologs, 2,3,7,8-tetrachlorodibenzodioxin, and 2,3,7,8-tetrachlorodibenzofuran) in the stack emissions;
- PCB, PCDD, and PCDF concentrations in any solid or liquid wastes generated; and
- Other parameters that demonstrate no unreasonable risk to the safety of the workers and the local community from PCBs, other hazardous chemicals/by-products, or other hazards (e.g., fires or explosions).

The monitoring and sampling plan also should identify the appropriate combustion system and pollution control system operating parameters that will be monitored and recorded during the test to establish operating limits that will be required during day-to-day operations (e.g., minimum residence time, batch feed operating parameters, liquid waste atomization parameters, scrubber water flow rate, pressure drop).

#### ***5.2.5.2 Pollutants and Parameters to be Monitored/Sampled during Tests for Alternative Non-Thermal Destruction/Removal Technologies***

The applicant should propose a set of test monitoring and sampling parameters to verify that the PCB treatment/destruction process: (a) has a level of performance equivalent to disposal in a § 761.70 incinerator or a § 761.71 high efficiency boiler; and (b) does not present an unreasonable risk of injury to health or the environment. At a minimum, this will include measurements of PCBs in the final product and effluent streams (wastewater, filters, vent gas, treated oil, etc.). For separation treatment processes (e.g., thermal desorption, carbon filtration) where PCBs are concentrated into a fraction for subsequent treatment/disposal by an approved method, the applicant should propose a set of monitoring and sampling parameters to verify that (a) the residual “clean” fraction contains  $\leq 2$   $\mu\text{g/g}$  (ppm) PCBs (see [section 2.4](#)), (b) any detectable levels of PCBs emitted from the system through drains, vents, etc. are within regulatory requirements (see [section 4.1.2](#)), and (c) the process does not present an unreasonable risk of injury to health or the environment. The monitoring and sampling parameters will depend upon the process design and the type of waste feed and effluent streams associated with the alternative treatment/disposal method. Process operating parameters that affect the performance of the unit (e.g., feed rate, reaction temperature, and pressure) should be monitored and recorded. The applicant should describe all the operating parameters that are necessary to assure compliance with the PCB regulations and to ensure no unreasonable risk of injury to health or the environment in the monitoring and sampling plan. This would include pollution control system operating parameters, if applicable.

EPA may require applicants to amend the list of pollutants or parameters to be monitored/sampled that they identified in the test plan. For example, EPA may request that additional pollutants, such as PCDDs, PCDFs, and other chlorinated organics, be included in the monitoring and sampling plan.



### **5.2.6 Test Plan Section VI - Monitoring Procedures**

For facilities using monitoring systems, a detailed discussion of the monitoring methods to be used during the test should be included in the test plan. While these procedures have been described in the approval application, the procedures should also be described in the test plan. We suggest that, at a minimum, all monitoring procedures that are specific to the test be included in the test plan. The following information should be included:

- Type of monitoring instrumentation used for the test;
  - Manufacturer and model number;
  - Monitor/instrument operational specifications (e.g., range, accuracy, and interferences);
  - Measurement frequency capabilities;
  - Operating temperature range of monitor, if monitor is *in-situ* type;
  - Description of the calibration procedures and frequency;
  - Provide an explanation if a specific instrument used for the test will not be used during normal operations;
- Description of monitor operation;
  - Discuss which pollutants/parameters will be monitored during the test, normal operations, or both;
  - Monitoring locations, and an explanation for why each location was chosen and results in representative samples/parameter measurements;
  - Provide an explanation if specific parameters monitored during the test will not be monitored during normal operations;
  - Frequency that the parameters will be monitored/recorded including a brief description of how the monitor output will be used to assure compliance;
  - Description of the data acquisition and recording system for all operating parameters, including a description of how the data acquisition system calculates and records operating parameter levels;
  - Description of the process to physically extract a sample if the monitor is extractive, including necessary sample conditioning systems (if applicable);
- Methodology for translating monitoring test results into the operating approval;
  - Proposed methodology to translate monitored test parameters into operating limits, if applicable (e.g., average of the test run averages);
  - Proposed methodology to be used to calculate parameter measurement frequency during normal operations to comply with operating limits that will be included in the operating approval, if applicable; and
  - Describe any data processing that will be done such as, data reduction procedures, calculations, etc.

Brief descriptions of some monitoring procedures typically used for PCB treatment/disposal technologies are presented in [Appendix C](#) and [Appendix E](#) of this document.

### **5.2.7 Test Plan Section VII - Sampling and Analysis Procedures**

Specific details of the sampling and analysis procedures that will be used during the test and that were not previously addressed in the approval application should be included, in detail, in the test plan. This section of the plan should also summarize the methods previously given in the approval application and any additional details or new information available at the time of the test.

EPA's SW-846 methods may be referenced and included as an appendix to the test plan. However, any deviations from standard procedures should be noted. Any modifications to the published procedures or selection from several options given in a procedure should be documented. Furthermore, when the standard method allows different procedural variations to be used, the applicant should be specific as to the procedures that will be followed (e.g., for the measurement of O<sub>2</sub> and CO<sub>2</sub> concentrations in the stack gas by EPA Method 3, will multi-point integrated sampling or single-point grab sampling be used?).

In some instances, the applicant may be asked to demonstrate equivalence between a method they are requesting and either a standard method or an EPA method, such as those found in SW-846. If this is the case, duplicate samples should be collected during the test and analyzed according to both methods (the proposed method and the standard or EPA method). The applicant should present the results in the test report ([section 7](#)) that compare the two methods and discuss how the two methods are equivalent. The applicant should also discuss how the proposed method does not present unreasonable risk of injury to health or the environment.

A discussion of the sampling and analysis procedure should be provided and may include:

- A summary of the sampling and analytical procedures;
  - This may overlap with the procedures discussed in the monitoring and sampling plan, in which case it may be referenced. For more information, see [section 4.2.7](#);
  - Be sure to include any information regarding the sampling method that may be missed in the monitoring and sampling plan. For example, the applicant may have indicated they were taking composite samples from a waste pile after treatment. There are many ways to composite samples; therefore, it is important that the compositing method is discussed in detail in this section;
  - Summarize analytical procedures and any procedures used to prepare the sample, including the EPA method numbers and deviations from the methods, the applicant's method numbers, and whether an on-site laboratory will be used;
  - Indicate the sampling locations, and an explanation for why each location was chosen and why it results in representative samples/parameter measurements;
  - Describe how the samples are stored, preserved, and recovered;
  - Discuss how samples are transported and custody is transferred;
- A description of the sampling and analytical equipment/apparatus used to take, transport, extract and analyze a sample;
  - The equipment manufacturer and model number;
  - Provide sampling and analytical equipment specifications, if applicable (e.g., range, accuracy, and interferences);
  - Describe how the sampling and analytical equipment is calibrated, standards used, and the frequency with which it is calibrated;
  - Describe any reagents used during sampling and analysis and discuss how the reagents will be prepared and used;
  - Describe the routine and preventive maintenance procedures and frequency;
- A description of any data processing that will be done, such as data reduction procedures, data validation procedures, calculations, etc.

Specific details of analytical procedures may be referenced (if standard published procedure) or should be included as an appendix (if unpublished or if the publication is not readily available). If needed,

include a description of when it is appropriate to analyze for PCBs as homologs or congeners.

[Appendices C](#) and [E](#) provide guidance on monitoring, sampling, and analysis procedures for various matrices and list various sample methods.

### ***5.2.8 Test Plan Section VIII - Emergency Procedures***

This section should describe the procedures to follow in the case of emergency situations. The discussion should explain the potential for release during the test and the potential fire hazards associated with the test. A list of emergency contacts and the location of the nearest hospital that is able and willing to treat injuries from hazardous substances should be included along with procedures for shutdown in case of an emergency.

### ***5.2.9 Test Plan Section IX - Test Data Reporting***

Present a summary of the data to be obtained during the test and presented in the final test report. Example calculations and reporting units should be presented. Include information, if applicable, for process data; pollution control system operating data; and the PCB concentrations for the waste feed, effluent waste, product streams, and emissions.

All applicable analytical values should be reported as concentrations, expressed as:

- Percent for O<sub>2</sub> and CO<sub>2</sub>;
- Parts per million for trace gases in air (e.g., CO);
- Micrograms per cubic meter for organics in air (e.g., PCBs);
- Micrograms per liter for water; and
- Micrograms per gram for nonaqueous liquids and solids;

PCB concentrations measured in the stack gas, waste feed, product oil, liquid waste, solids waste and other streams are to be reported. A breakdown of the PCB value by homolog or congener may be useful for certain destruction tests, as this will reveal whether destruction was incomplete, or PCB destruction levels met the performance standards. In many cases for alternative methods of PCB destruction, destruction equivalence to a § 761.70 incinerator has been defined as a measured effluent stream concentration of not greater than 2 ppm.<sup>53</sup> The analytical results may not be reported in terms of Aroclor (or other mixture) concentrations, even if an Aroclor is used to calibrate the instrument (as in the waste feed), unless prior EPA approval is obtained.

PCDDs and PCDFs are to be reported by homolog (e.g., total octachlorodibenzofurans) for the tetra- through octachloro homologs and summed to give total PCDD and PCDF values as a minimum. Concentrations may be calculated on a toxic equivalents (TEQ) basis, which are the units of measurement for reporting under the Clean Air Act NESHAP regulations in 40 CFR part 63, subpart EEE. Separate values should be reported for 2,3,7,8- tetrachlorodibenzodioxin (TCDD) and 2,3,7,8- tetrachlorodibenzofuran (TCDF).

Other contaminants detected should be reported as quantitated, with the sampling and analytical methods used to detect the subject compound listed.

---

<sup>53</sup> Previous guidance has interpreted that “equivalent level of performance” to an incinerator means less than or equal to 2 ppm. See “Guidelines for Permit Applications and Demonstration Test Plans for PCB Disposal by Non-Thermal Alternative Methods” (1986).

### ***5.2.10 Test Plan Section X - Miscellaneous Tests***

The proper operation of the automatic waste feed cutoff and other emergency systems should be demonstrated upon request. Describe the procedures to be used during the test to check operation of alarm and emergency systems, including:

- Automatic waste feed cutoff system;
- Alarm systems (e.g., high temperature); and
- Fire extinguisher system.

These operational checks should be included as part of the test schedule described in [section 5.2.12](#) below. The checks should be conducted with non-TSCA regulated feed and may be conducted prior to, or after testing to minimize downtime during the testing process.

If the facility is permitted under the Resource Conservation and Recovery Act (RCRA), copies of the most recent RCRA performance test that a state or Region has certified as having passed should be provided. Additionally, if the facility is required to have a Clean Air Act Title V permit then copies of the CAA permit should also be provided. EPA will review these permits when evaluating a request for an approval.

### ***5.2.11 Test Plan Section XI - Waste Handling and Disposal***

The test plan should identify any by-product wastes (both PCB and non-PCB) that will be generated (e.g., in-line filters for the PCB waste feed line, samples of feed material, contaminated PPE) and how the wastes will be disposed of. This includes PCB wastes that are, for example, treated in tests and are later determined to not pass the treatment efficiency standards (e.g., oil contaminated with PCBs that cannot be treated to levels less than or equal to 2 ppm).

### ***5.2.12 Test Plan Section XII - Test Schedule***

A detailed schedule of the proposed testing period, including when any shakedown tests will be conducted, should be provided in the test plan. The schedule should be of sufficient detail to determine what activities are planned for each phase of the test. Tables 12 and 13 provide examples of test schedules for incineration and alternative treatment/disposal methods, respectively. The test schedule should be realistic, including sufficient time to address problems that are likely to occur during operation of a new process.

**Table 12. Example: Proposed Schedule for an Incinerator Test <sup>1</sup>**

<b>Day</b>	<b>Tentative Date</b>		<b>Activity</b>
-5	xx/yy/zz	AM/PM	Inventory waste feed
		AM/PM	Begin system shakedown using auxiliary fuel
-4	xx/yy/zz	AM/PM	Continue system shakedown
		AM/PM	Calibrate continuous emissions monitoring system
-3	xx/yy/zz	AM/PM	Continue system shakedown
		AM/PM	Check emergency alarm/cutoff systems
-2	xx/yy/zz	AM/PM	Continue system shakedown
-1	xx/yy/zz	AM/PM	Continue system shakedown
		AM/PM	Continue system shakedown <sup>2</sup>
0	xx/yy/zz	AM/PM	Test crew arrives on-site
		AM/PM	Test equipment set-up
1	xx/yy/zz	AM/PM	Begin PCB destruction
		AM/PM	Emission test No. 1 <sup>3</sup>
2	xx/yy/zz	AM/PM	Emission test No. 2 <sup>3</sup>
			Emission test No. 3
3	xx/yy/zz	AM/PM	Test of emergency systems
			Shut unit down at completion of test according to test plan

<sup>1</sup> **DISCLAIMER:** This table is only an example and may not capture every relevant parameter, nor is every parameter listed in the table relevant to all technologies. Furthermore, applicants are not required to use this table.

<sup>2</sup> System shakedown should continue until system is able to operate without significant downtime (e.g., a minimum 24 hours of operating time without significant downtime is suggested).

<sup>3</sup> Unit will be returned to auxiliary feed at end of each emission test; unit will be switched to PCB waste, prior to starting the next test period.

**Table 13. Example: Proposed Schedule for an Alternative Method of Treatment/Disposal Test <sup>1</sup>**

Day	Tentative Date		Activity
-1	xx/yy/zz	AM/PM	Inventory waste feed
		AM/PM	Begin system shakedown using non-TSCA regulated feed
		AM/PM	Check emergency alarm/cutoff systems
0	xx/yy/zz	AM/PM	Continue system shakedown using non-TSCA regulated feed
		AM/PM	Test crew arrives on-site
		AM/PM	Test equipment set-up
1	xx/yy/zz	AM/PM	Destruction test No. 1
2	xx/yy/zz	AM/PM	Destruction test No. 2
3	xx/yy/zz	AM/PM	Destruction test No. 3
			Test of emergency systems
			Shut unit down at completion of test according to test plan

<sup>1</sup> DISCLAIMER: This table is only an example and may not capture every relevant parameter, nor is every parameter listed in the table relevant to all technologies. Furthermore, applicants are not required to use this table.

### 5.2.13 Test Plan Section XIII - Quality Assurance Project Plan

Each test plan should include a QAPP (see [Appendix D](#) for an optional QAPP template). The applicant may want to contact the Regional office for any region-specific considerations. If an adequate QAPP has been submitted with the approval application (see [section 4.2.20](#)), then only addenda to the QAPP specific to additional sampling, monitoring, and analysis for the test need to be submitted with the test plan. Those portions of the QAPP that apply to normal operations and those that apply only to the test should be clearly identified. In any event, the QAPP, with addenda, should address all measurement parameters (e.g., CO emissions, combustion chamber temperature, destruction vessel temperature, distillation column temperature), not merely PCB sampling and analysis.

Below is a short list of items that should be included in a QAPP specifically for the test (a complete list of items to include in a QAPP, with a description of each, can be found in [section 4.2.20](#)):

- Distribution list and responsibility for QA;
- Quality objectives and criteria (precision, accuracy, completeness, representativeness, and compatibility);
- Sample handling and custody;
- Monitoring design and procedures;
- Sample and analytical design and procedures;
- Quality control;
- Instrument/equipment testing, inspection, and calibration procedures and frequency;
- Data reduction, validation, and reporting;
- Performance and system audits and frequency;
- Preventive maintenance procedures and schedules;

- Data management;
  - Specific routine procedures to assess data precision, accuracy, and completeness;
- Assessments and response actions; and
- QA reports to management.

The QAPP should conform to the specifications established in Guidance for Quality Assurance Project Plans, EPA QA/G-5 (US EPA 2002). Additional guidance in the preparation of QAPPs is available in “EPA Requirements for Quality Assurance Project Plans” (U.S. EPA, 2001).

For most sampling and analysis plans, a minimum of 10 percent or 2 of the samples, whichever is greater, should be collected in triplicate; a minimum of 10 percent or 2 of the samples, whichever is greater, should be quality control (QC) samples; and a minimum of 10 percent or 2 of the samples, whichever is greater, should be QC blanks.

#### ***5.2.14 Test Plan Section XIV - Standard Operating Procedures***

Provide any addenda to the standard operating procedures (SOP) submitted with the approval application (see [section 4.2.21](#)), if necessary. Those portions of the SOP that apply to normal operations and those that apply only to the test should be clearly identified.

## SECTION 6

### CONDUCTING AND MONITORING A TEST

Once EPA has determined that the test plan is satisfactory, the agency will issue approval to the applicant, and a testing date agreeable to both the applicant and EPA will be set.<sup>54</sup> A test approval will generally contain conditions addressing, for example, advance 30-day notification of the test to other appropriate authorities (i.e., EPA regional Administrator, state and local agencies), permissible PCB-containing material(s) to be treated, as well as sampling and analysis, waste disposal, QA, recordkeeping, and reporting requirements applicable to the testing period. The applicant should check with the approval writer to determine if other steps, such as public notice, may be needed prior to test approval.<sup>55</sup> A copy of the test approval should be located on-site and adhered to during the test.

If any modifications to the test plan are needed prior to the test, notify EPA (approval writer) in writing at least 14 days prior to the test or as specified in the test plan approval. Also, if events warrant that the plan be significantly modified during the test, then the approval writer should be contacted immediately to discuss the implications of any modifications.

The test should be conducted under conditions simulating reasonable most challenging operational conditions (e.g., minimum temperatures or maximum flow rates). Operating approval limits/requirements usually reflect the operating conditions during the test. Therefore, as discussed in [section 5](#), the applicant should have given careful consideration to the design and implementation of the test in the test plan.

#### 6.1 Expected Responsibilities During the Test

The following section discusses the anticipated responsibilities of EPA personnel witnessing the test and the suggested responsibilities of the facility personnel/applicant conducting the test.

##### 6.1.1 EPA's Role

When the test begins, EPA's primary role is to observe the test. This may include looking at gauges, instrument panels, control center panels, and other various components of the process. EPA officials may also ask the operators or other facility personnel questions about the process, any sampling to be conducted, or about various control/instrument panels that are monitoring the PCB disposal unit. EPA should be notified prior to collecting any samples because EPA personnel may wish to observe the sample collection. If sampling occurs without EPA knowledge, the sample may be disqualified and the test run may not count if treatment cannot be verified. Due to liability concerns, EPA will not:

- Give any direction or instruction during the test (e.g., suggesting that the temperature should be increased or decreased);
- Touch any components of the system (e.g., valves, buttons or other components);
- Help the operators run the treatment unit. For example, if an operator is assigned to monitor certain gauges and they need to step away temporarily, then the operator should request another operator or a manager to temporarily step in to monitor the gauges. EPA personnel are not responsible for any issue that may arise if the unit is left unattended;
- Touch any of the applicant's sampling equipment or collected samples; or

---

<sup>54</sup> As a reminder, trial burns and demonstration tests are referred to collectively as tests.

<sup>55</sup> See [section 8](#) for more information on public engagement.



- Collect samples on behalf of the facility (though EPA may request that the facility operators collect duplicate samples on behalf of EPA).

EPA reserves the right to end the test and leave the facility at any point. Reasons for ending a test may include:

- Runs cannot be completed after three attempts;
- PCBs are not sufficiently destroyed or removed from the media based on preliminary data after three attempts;
- Steady-state conditions could not be achieved after two days;
- Equipment failure occurs and it cannot be repaired within two days;
- Unexplained data quality or operational parameter monitoring issues occur during the test;
- Hazardous conditions occur at the facility (e.g., fire or explosion occurs); and/or
- Another disruptive event, such as a natural disaster (e.g., hurricane, earthquake, or tornado) or a power outage, occurs at the facility.

### **6.1.2 The Facility's Role**

The primary roles of the facility personnel conducting the test are to ensure they are operating the treatment unit as stated in the conditions of the test approval issued by EPA and communicating with EPA personnel witnessing the test. If the facility cannot meet the conditions stated in the approval, then it is strongly suggested that the facility personnel notify EPA as soon as possible. If significant delays occur during the test and EPA is not made aware of the issues causing the delay in a timely matter, then EPA personnel may leave and effectively end the test. Discussing any issues that arise during the test with EPA in a timely fashion may allow for a quicker resolution so that future test runs have acceptable results. Also, if needed, EPA personnel may allow for modifications of the test approval during the test.

Important items that the facility operators or personnel should communicate to on-site EPA personnel during the test are:

- Various stages of the treatment process (e.g., start-up, achieving steady-state, adding PCB waste);
- Regular reports on the operational performance of the unit;
  - Current operational measurements (e.g., temperature, pressure);
  - Air emissions monitoring performance (e.g. preliminary isokinetic calculations);
  - Sample results, if there is a quick turnaround for results;
- Any sample collection related to the test run (which may be witnessed by EPA personnel);
- Any required notification, as stated in the approved test plan; and
- Any issues that have occurred during the test.

An “event log” should be maintained throughout the test and submitted as part of the test report.

## **6.2 Preparing for the Test**

In advance of the test, the principal manager should ensure that the facility is prepared for testing of the PCB treatment unit. All instruments, controls, devices, etc., should be in working order and calibrated. All continuous emissions monitors such as oxygen, carbon monoxide, and carbon dioxide should pass zero drift and span drift tests. EPA may provide an audit cylinder for one or more of these monitors for a performance demonstration during the test. Sufficient supplies of PCB waste, fuel, reagents, etc., should

be on hand. If media will be spiked with PCBs then the concentration of the PCBs should be known and the target PCB concentration within the media should be calculated. It is suggested that sampling equipment be prepared, containers labeled accordingly, and the lab prepared to process the samples. The checklists provided in [Appendix F](#) may be helpful when preparing for the test.

Provided that other local, state, and federal regulations allow it, one or more pre-tests, known as shakedowns, may be conducted using a non-TSCA regulated feed (less than or equal 2 ppm) to practice operating a unit. EPA may also approve processing a limited quantity of PCBs in an alternative treatment unit under an R&D approval prior to a full-scale test (see [section 4.1.4](#)). EPA encourages applicants to thoroughly shake down new units before any PCBs are introduced into the treatment/disposal system. The facility should certify that its continuous emissions monitors (CEMs) such as oxygen, carbon monoxide, and carbon dioxide, have passed the appropriate tests such as zero drift and span drift tests. EPA may order an audit cylinder for one or more of these monitors that can be delivered to the facility for them to demonstrate during the test.

Before starting up the unit, regulatory officials (this may include both EPA and state officials) may arrive to witness the test. It is suggested that the principal manager provide a brief run-through of the test plan and discuss any last-minute concerns. It is also suggested that the principal or facility manager provide a safety briefing on its safety and evacuation plan for emergency and/or mechanical breakdown situations. EPA personnel are typically required to take 40-hour Hazardous Waste Operations and Emergency Response (HAZWOPER) training with a refresher every two years, but safety protocols specific to the facility should also be discussed and any site-specific hazards should be identified. For example, ear plugs or respirators may be needed in a room where certain samples are taken during the test. EPA personnel will generally bring steel toe boots, hard hats, and safety vests. If additional safety equipment is needed during the test, notify EPA prior to arriving at the facility.

### **6.3 Three Phases of a Test**

Each test of a PCB treatment/disposal unit usually consists of three phases: start-up, treatment/disposal, and shutdown. Each phase is discussed below.<sup>56</sup>

#### ***6.3.1 Phase I: Start-up of the Treatment/Disposal Unit***

Start-up is conducted to ensure that the facility is prepared to begin processing PCB waste. For both continuous operations and batch operation, the system is typically brought up to steady-state conditions prior to feeding any PCBs into the system. When the operating parameters reach the planned levels for the test, the time and conditions should be noted, air emissions sampling should begin, if applicable, and samples should be collected to characterize background conditions for quality control, if applicable. PCB waste should not be introduced into the system until all required monitoring devices are operational and recording necessary parameters. Waste should also not be fed to the treatment unit between test runs unless provided otherwise in the approval test plan.<sup>57</sup>

---

<sup>56</sup> As discussed previously, be sure to communicate with on-site EPA personnel during each phase. There may be specific points during the test that EPA personnel will want to observe.

<sup>57</sup> Do not confuse start-up with shakedown. A shakedown should occur before the scheduled test and with non-TSCA regulated waste to practice operating the unit. Practice operating the unit may include all three phases: start-up, treatment, shutdown.

### ***6.3.2 Phase II: Treatment/Disposal of PCB Waste***

At this point the treatment unit should have reached steady-state conditions, sampling/monitoring procedures should have started, and, for continuous operations, PCB waste should now be introduced into the unit at expected maximum feed rates and maximum PCB concentrations.

During phase two, samples should be collected and records kept of all operating conditions stated in the test plan (e.g., continuous monitors, gauges, and meters). Visual observation of the effluent also should be made, where appropriate. Quick turnaround times for the samples during the test will allow for a quick assessment of the unit's performance and for discussion of any identified issues with on-site EPA personnel. If, after the first run, an issue is identified and remediated or a minor change to the test plan is made, on-site EPA personnel may allow the test to continue for an additional test run rather than scheduling a future test so that three successful test runs can be completed during the same test. Any issues with or changes to the test plan should be documented in the test report.

The length of individual test runs will depend on the specific disposal process. A three to four-hour emissions test is typical for incinerators or alternative thermal destruction technologies, with three test runs conducted on successive days. For stack emission testing, the probe should be inserted into the stack after steady state is reached, usually about 30 minutes after starting the PCB waste feed. This allows sufficient time for volatilization and destruction of PCBs in the combustion chamber(s) and for sampling of representative combustion gas emissions during PCB incineration.

Testing a batch type treatment/disposal process might consist of test runs of three separate batches. The length of time to complete each batch is based on the treatment type and the operational parameters of the unit, such as PCB concentration, quantity of the PCB waste, temperature, media type, etc. Typically, it will take several hours to complete a run. If a run will last longer than 12 hours, EPA requests prior notification, as additional EPA and/or state regulatory personnel will be needed for additional shifts. In rare occasions when an extremely long test is approved (weeks or months long), then alternative measures may be needed, such as alternative monitoring measures, restricted access, and evidence tape.

### ***6.3.3 Phase III: Shutdown of the Treatment/Disposal Unit***

After testing is complete for the process or paused between individual test runs that occur on separate days, the waste feed should be terminated and the system shut down per normal procedures. For certain processes, such as incinerators, the system may be kept running on non-TSCA regulated waste at the discretion of the operator. This would allow a test run on a subsequent day to begin with minimal time needed to obtain steady-state conditions during the start-up process.

## **6.4 Completed Test**

A test may conclude once three test runs are completed as described above ([section 6.3](#)) or if EPA or the applicant decides to end the test prematurely. The applicant should review any available results of the test runs and provide those results before EPA leaves the site (e.g., isokinetic results of each run). As previously mentioned, test runs can be evaluated using monitoring data and preliminary sampling results to identify indications of passing. EPA may not accept data collected after EPA leaves the site. If the applicant is concerned about the results, the applicant can discuss this with EPA before EPA personnel leave the site in order to find a resolution. EPA may allow the applicant to conduct an additional test run. For example, if a sampling probe broke during a test run, EPA would likely allow the applicant to conduct another test run if the facility is able to readily replace the probe. If significant changes are

needed to the operating conditions then a new test approval may be required.

#### ***6.4.1 An Acceptable Test***

A test run should meet the criteria stated in [section 4.1.2](#). To determine if a run meets these criteria, samples should demonstrate destruction or removal of PCBs from the media as stated in the test approval. Typically, for batch systems, steady-state conditions should be maintained for enough time such that destruction/removal of PCBs to appropriate levels is achieved. For continuous operations, such as catalytic hydrogenation, the unit may run for several residence times to complete one test run and achieve appropriate destruction levels. Furthermore, if applicable, air sampling data must demonstrate at least 99.9999% destruction of the PCBs. EPA generally asks for three acceptable runs to be completed prior to issuing an operating approval.

#### ***6.4.2 A Failed Test***

A test may fail for several reasons (see [section 6.1.1](#) for a more detailed discussion). Typically, a test may fail if the treatment unit was unable to destroy PCBs to an acceptable level, all three runs could not be completed, or a run was conducted without EPA approval. Furthermore, it may not be known whether a unit failed a test until the data are obtained and analyzed. Regardless of whether a test passed or failed, EPA recommends that a test report be completed and submitted.

## SECTION 7

# TEST REPORTS

After a test approval is issued and the test has been completed, a report of the results should be prepared and submitted to EPA.<sup>58</sup> This section presents the suggested format for a test report and discusses the information that should be provided. Note that a test report should be submitted to EPA regardless of whether the technology passes or fails the test. The report should be submitted to the same delegated EPA official as the test plan (see [section 2.2](#)). While electronic submission of files is preferred, EPA will occasionally request paper copies of the test report. Contact EPA personnel to receive specific instructions for submitting CBI material (see [section 4.1.5](#) for more information). Following receipt and review of the test report, EPA will begin drafting an operating approval, ask for more information, or deny the request for an operating approval. If the technology failed the test, EPA will notify the applicant and provide the basis for determining the test was failed. If EPA determines the test results adequately demonstrate that the facility has passed all applicable requirements, then EPA will begin drafting the operating approval. The applicant is encouraged to communicate with EPA if assistance is needed when developing the test report.

### 7.1 General

A test report should discuss the sampling results, monitoring data, and general operation of the technology observed during the test. Much of the content may have already been identified in the test plan or approval application. This generally includes:

- Time, date, and location of the test;
- Quantity and type of PCBs and PCB Items treated/removed during the test;
- Summary of methods used to monitor the process operation and for sample analysis;
- Process operation and emission results;
- Sampling test results; and
- Quality assurance report with name, address, and qualifications of persons who reviewed analytical results and other pertinent data.

To help expedite the review process, EPA suggests including the page number or section number of any referenced document or data from the test plan or approval application. Additionally, it may be beneficial for the applicant to review previous sections of the guidance that may help with the development of the test report, such as criteria ([section 4.1.2](#)) and purpose of a test ([section 5.1.1](#))

In instances where the applicant is submitting a revised test report based on comments received from EPA, or due to proposed changes to a previously submitted report, the applicant should summarize such changes/revisions up front (see [section 7.2.4](#)), and if practicable, provide a redline/strikeout “compare” version that highlights the revisions that have been made.<sup>59</sup> The applicant is also encouraged to provide EPA with a standalone response to comments document that briefly explains/summarizes how each EPA comment was addressed in order to facilitate the EPA review process.

In instances where significant deficiencies have been identified by EPA, or the applicant is unclear as to

---

<sup>58</sup> As a reminder, trial burns and demonstration tests are referred to collectively as tests.

<sup>59</sup> In instances where significant revisions or rewrites have been made, a redline/strikeout compare version may not be practicable/useful.

how to address specific deficiencies, the applicant may find it useful to request a meeting or teleconference with the approval writer to help ensure the revisions adequately address the comments received. EPA may deny the application if the deficiencies are not addressed within a reasonable period of time.

Following EPA’s review of the test report and any supplemental information, EPA will either begin to draft the operating approval or deny the applicant’s request for an operating approval. Specific conditions will be included in an approval and must be followed when operating under the approval (see [section 8](#) for more information). Note that the conditions in the operating approval will be based on the parameters and operating performance observed during the test and, as a result, these conditions may differ from the conditions in the test plan approval. If an operating approval is denied but the applicant is still interested in an approval, then a new application and test plan should be submitted to EPA and a new test will likely be required. Any subsequent test plan and operating approval applications should directly address the deficiencies that were identified in the operating approval denial.

## 7.2 Contents of Test Reports

Table 14 presents the suggested format for the test report.

**Table 14. Suggested Format for the Test Report**

Section No.	Section Title
	Test Report Cover
	Table of Contents
	Certification Letter
I	Summary
II	Process Operation
III	Monitoring and Sampling Procedures
IV	Analytical Procedures
V	Test Results
VI	Quality Assurance Summary
VII	Visits and Audits
VIII	Waste Handling and Disposal
	Appendices

### 7.2.1 Transmittal Letter

All test reports should be accompanied by a transmittal letter which summarizes the test results and any major modifications to or deviations from the test plan made during the test. If the test was completed for the purposes of renewing an operating approval, the applicant should briefly summarize how/whether their operations will differ from their previous operating approval.

### 7.2.2 Cover Page

A suggested cover page format for the test report is shown in Figure 7. The main cover should reference

when the applicant submitted the test plan and operating approval application and when EPA approved the test plan. If a paper copy is requested by EPA and if the report volumes or the appendices are bound separately, each part of the submission should be numbered in order in the upper right-hand corner of the cover (“Volume m of n”). The covers of each volume should have the full cover information shown in Figure 7.

### ***7.2.3 Certification Letter***

The test report should include a letter, signed by an authorized official, certifying on behalf of the applicant that the information contained in or accompanying the document is true, accurate, and complete. 40 CFR 761.3 provides the necessary language for a certification letter. This may be a signed statement within the report rather than a separate letter. The signed certification letter may be submitted via email.

### ***7.2.4 Test Report Section I - Summary***

The test report should begin with a narrative that summarizes the overall performance of the technology during the test. The narrative should highlight important operational parameters and whether the facility met all performance standards and regulatory requirements. It is recommended that this section include table(s) summarizing the pertinent test results. Major problems and deviations from the test plan should also be summarized.

### ***7.2.5 Test Report Section II - Process Operation***

The following sections discuss the process operation information suggested for inclusion in the test report.

#### ***7.2.5.1 General Process Operation Information***

A general overview of the process operations using simplified flow diagrams and a brief narrative should be provided. Detailed information on the process operations should have been stated in the approval application or test plan and may be referenced in the test report. When referencing the application or test plan, EPA suggests including the page number or section number of where the information is located.

When providing data, a tabular format with explanatory narrative, as applicable, is preferred. Table 15 is an example summary table of the results for an incinerator or an alternative thermal destruction technology test and Table 16 is an example summary table for a non-thermal destruction/removal technology test. Detailed data such as data logs (e.g., tables of temperature recordings) and the process operator’s log should be presented in an appendix. Detailed data may be summarized in the narrative or in a table as an average and/or a min/max range observed during the test. All the results should be compared to the anticipated operating ranges/levels discussed in the test plan and any results outside the anticipated levels should be highlighted. A discussion regarding any deviation from the test plan should be included in the test report; more details regarding deviations are provided in [section 7.2.5.4](#).

Note that, due to the variety of technologies that currently exist, the example tables may not capture every relevant parameter, nor is every parameter shown in the tables relevant to all technologies. The applicant should be proactive in identifying and including applicable information so the test report is thorough, but also clear to the approval writer; otherwise, the operating approval may be delayed or denied.

TEST REPORT, VERSION # X (IF APPLICABLE)<sup>60</sup>

PCB TREATMENT/DISPOSAL UNIT

*[Type and location of unit]*

*[Name and location of company headquarters if different from above]*

Operating Approval Application Submission Date: *[date]*

Test Plan Submission Date: *[date]*

Test Date(s): *[date(s)]*

Test Report Submission Date: *[date]*

Submitted by:  
*[Company name and address]*  
*[Principal manager]*  
*and phone number]*

Submitted to:  
Director, Office of Resource Conservation and Recovery  
Office of Land and Emergency Management  
U.S. Environmental Protection Agency  
1200 Pennsylvania Avenue, NW  
Mail Code 5303P  
Washington, DC 20460  
[ORCRPCBs@epa.gov](mailto:ORCRPCBs@epa.gov)

OR

If submitted to an EPA Regional office, provide the applicable Region's address listed at [www.epa.gov/pcbs/program-contacts](http://www.epa.gov/pcbs/program-contacts).

**Figure 7. Test Report Cover Page Example.**

---

<sup>60</sup> If the document is revised and resubmitted to EPA, the applicant should clearly indicate on the cover that the report has been updated (e.g., version 2).



**Table 15. Example Test Results Summary Table for Incinerator or Alternative Thermal Destruction Technology <sup>1,2</sup>**

	Test Run 1	Test Run 2	Test Run 3
Date	_____	_____	_____
Time test begun	_____	_____	_____
Time test ended	_____	_____	_____
Operating parameters:	_____	_____	_____
Max/Avg. waste feed rate (kg/h)	_____	_____	_____
Min/Avg. treatment unit temperature	_____	_____	_____
Max/Avg. PCB concentration (g/kg)	_____	_____	_____
Max/Avg. PCB feed rate (kg/h)	_____	_____	_____
Auxiliary fuel feed rate (kg/h)	_____	_____	_____
Total thermal load (10 <sup>6</sup> Btu/hr)	_____	_____	_____
Residence time (seconds)	_____	_____	_____
Minimum combustion air flow (acm/min)	_____	_____	_____
Avg. O <sub>2</sub> (%)	_____	_____	_____
Avg. CO <sub>2</sub> (%)	_____	_____	_____
Avg. CO (ppm)	_____	_____	_____
Combustion efficiency (%)	_____	_____	_____
Min/Avg. scrubber water flow (gpm)	_____	_____	_____
Min/Max scrubber water pH	_____	_____	_____
Min/Avg. Venturi water flow (gpm)	_____	_____	_____
Avg. Venturi pressure drop (inches H <sub>2</sub> O)	_____	_____	_____
Particulate/HCl emissions:	_____	_____	_____
Total sample time (min)	_____	_____	_____
Total sample volume (dscm)	_____	_____	_____
Stack gas flow rate (dscm/min)	_____	_____	_____
Particulate concentration (mg/dscm)	_____	_____	_____
Chlorine (g/min)	_____	_____	_____
HCl removal (%)	_____	_____	_____
PCB emissions:	_____	_____	_____
Total sample time (min)	_____	_____	_____
Total sample volume (dscm)	_____	_____	_____
PCB feed rate (g/min)	_____	_____	_____
PCB output rate (g/min)	_____	_____	_____
PCB DRE (%)	_____	_____	_____
PCDD/PCDF emissions:	_____	_____	_____
Total sample time (min)	_____	_____	_____
Total sample volume (dscm)	_____	_____	_____
Total PCDD emissions (ng/dscm)	_____	_____	_____
Total PCDF emissions (ng/dscm)	_____	_____	_____

<sup>1</sup> DISCLAIMER: This table is only an example and may not capture every relevant parameter for thermal destruction technologies, nor is every parameter listed in the table relevant to all technologies. Furthermore, applicants are not required to use this table.

<sup>2</sup> The units may be different depending on the technology.

**Table 16. Example Test Results Summary Table for an Alternative Non-Thermal Destruction/Removal Technology <sup>1,2</sup>**

	Test Run 1	Test Run 2	Test Run 3
Date	_____	_____	_____
Time test begun	_____	_____	_____
Time test ended	_____	_____	_____
Operating parameters:	_____	_____	_____
Max/Avg. waste feed rate (kg/h)	_____	_____	_____
Max/Avg. PCB concentration (g/kg)	_____	_____	_____
Max/Avg. PCB feed rate (kg/h)	_____	_____	_____
Auxiliary fuel feed rate (kg/h)	_____	_____	_____
Residence time (seconds)	_____	_____	_____
Reagent Feed Rate (kg/h)	_____	_____	_____
Flow rate through reactor chamber (l/min)	_____	_____	_____
Pressure in reactor chamber (psi)	_____	_____	_____
Temperature in reactor chamber (°C)	_____	_____	_____
Product effluent flow rate (kg/hr)	_____	_____	_____
Effluent wastewater flow rate (l/min)	_____	_____	_____
PCB concentration in effluent streams (ppm or ppb)	_____	_____	_____
By-product concentration (ppm)	_____	_____	_____
Vent emissions:	_____	_____	_____
Total sample time (min)	_____	_____	_____
Total sample volume (dscm)	_____	_____	_____
Stack gas flow rate (dscm/min)	_____	_____	_____
Volatile organic compound (VOC) (g/min)	_____	_____	_____
Chlorine (g/min)	_____	_____	_____
HCl removal (%)	_____	_____	_____
Particulate concentration (mg/dscm)	_____	_____	_____

<sup>1</sup> DISCLAIMER: This table is only an example and may not capture every relevant parameter for non-thermal destruction/removal technologies, nor is every parameter listed in the table relevant to all technologies. Furthermore, applicants are not required to use this table.

<sup>2</sup> The units may be different depending on the technology.

**7.2.5.2 Pollutants and Parameters Monitored/Sampled during Tests for Incinerators or Alternative Thermal Destruction Technologies**

The applicant should present and discuss the process operating parameters, pollution control system parameters, and emissions that were recorded during the start-up, operation, and shutdown phases of thermal tests.<sup>61</sup> These results should be compared to the target values provided in the test plan. The minimum monitoring and recording requirements for incinerators, as provided in 40 CFR 761.70, to be discussed in the test report include:

- The waste feed rate, quantity and recording intervals;
- The combustion temperature and recording frequency;
- The concentrations of combustion products (e.g., O<sub>2</sub>, CO, and CO<sub>2</sub>); and

<sup>61</sup> See sections [4.2.7](#) and [5.2.6](#) for more information regarding monitoring and sampling plans.

- The concentrations of stack emission products that were monitored (e.g., NO<sub>x</sub>, HCl, residual Cl, PCBs, and total particulate matter).

Any additional monitoring and sampling parameters beyond those listed in § 761.70 that were applied to ensure the operation of the PCB treatment/disposal method does not present an unreasonable risk of injury to health or the environment or, for alternative thermal destruction technology, to achieve a level of performance equivalent to disposal by an incinerator approved under § 761.70, should be discussed.<sup>62</sup> EPA may include limitations for these operating parameters in the operating approval based on the levels demonstrated during the test (see [section 5.1.1](#) for more information). Additional parameters to discuss in the test report will vary based on the design of the treatment/disposal unit but may include:

- The PCB content of the waste feed and Destruction and Removal Efficiency (DRE) calculations;
- The concentrations of dioxins and furans in the stack emissions;
- The PCB, dioxin, and furan concentrations in any solid or liquid wastes generated;
- Observed parameter values that indicate proper treatment performance (e.g., minimum residence time, batch feed operating parameters, and liquid waste atomization parameters);
- Observed parameter values that indicate proper operation of the pollution control systems (e.g., scrubber water flow rate, pH, pressures, and temperatures); and
- Observed safety parameter values that demonstrate no unreasonable risk to workers and the local community from PCBs, other hazardous chemicals/by-products, or other hazards (e.g., fires or explosions).

### ***7.2.5.3 Pollutants and Parameters Monitored/Sampled during Tests for Alternative Non-Thermal Destruction/Removal Technologies***

Monitoring and sampling parameters to be included in the test report for non-thermal destruction/removal technologies should verify that the applicant's PCB treatment/destruction process achieved a level of performance equivalent to disposal in a § 761.70 incinerator or a § 761.71 high efficiency boiler and will not present an unreasonable risk of injury to health or the environment, as required under § 761.60(e). The applicant should present and discuss the process operating parameters, pollution control system parameters, and any effluent streams that were recorded during the start-up, operation, and shutdown phases of non-thermal tests. These results should be compared to the values reported in the test plan. The monitoring and sampling parameters for non-thermal technologies will depend upon the process design and the waste feed and effluent streams associated with the non-thermal alternative treatment/disposal method. The applicant should discuss:<sup>63</sup>

- At a minimum, the PCB concentrations in the final product and in all effluent streams (wastewater, filters, vent gas, treated oil, etc.);
  - If using separation treatment (e.g., carbon filtration) then verify the concentration of PCBs in the clean fraction(s);
  - Discuss air emission results if air sampling was required;
- Monitoring results of any reactant/oxidant/fuel/catalyst and their feed rate into the system;
- Observed performance parameter values that indicate effective treatment (e.g., minimum residence time, batch feed operating parameters, and liquid waste atomization parameters);<sup>64</sup>
- Observed pollution control system operating parameter values that indicate proper operation

<sup>62</sup> 40 CFR 761.70(d)(4)(ii), 60(e).

<sup>63</sup> See sections [4.2.7](#) and [5.2.6](#) for more information regarding monitoring and sampling plans.

<sup>64</sup> Remember, as previously discussed in [4.1.3](#), there will likely be fewer operating process limits for processes where treatment efficiency can be verified as opposed to treatment systems that rely on indirect parameters to assure compliance.

(e.g., pressure drop, temperature, flow rate, etc.);

- Quantity and concentrations of hazardous by-products produced by the treatment process; and
- Observed safety parameter values that demonstrate no unreasonable risk to workers and the local community from PCBs, other hazardous chemicals/by-products, or other hazards (e.g., fires or explosions).

#### 7.2.5.4 Deviations from the Test Plan

The applicant should provide a discussion of any modification made to the operating parameters or any events such as upsets, unplanned shutdowns, or other deviations from the approved test plan that occurred during the test. The applicant should explain why the event occurred and discuss the effect on the test results and on the overall ability of the system to routinely operate within expected approval conditions. Note that control limits (i.e., acceptable ranges) will be listed in the operating approval, and will be based on the operating parameters of a successful test. If the operating parameters demonstrated during a successful test differed from the target parameter levels proposed in the test plan, then the demonstrated parameters rather than the parameters listed in the test plan will likely be used to establish the operating approval conditions (see [section 5.1.1](#) for more information). A modification to the approval conditions can be requested after the approval is issued but a new test may be required.

**PARAMETER VALUES DEMONSTRATED, NOT THE TARGET PARAMETER VALUES STATED IN THE TEST PLAN, WILL BE USED TO DEVELOP THE OPERATING APPROVAL CONDITIONS.**

The test report should also contain a discussion regarding any non-incident-related changes to the test plan such as site location, quantity of PCBs treated, or use of an independent laboratory for analysis. The purpose or reasons for these types of changes should be explained.

EPA requests that deviations from the approved test plan also be verbally reported to the approval writer during the test and as a separate incident report within 14 days of the incident. Any corrective actions conducted for each event also should be provided to the approval writer and should be presented in an appendix of the test report.

#### 7.2.6 Test Report Section III - Test Results

The test report should discuss the test sample results, QA/QC results, and system performance, as applicable. All analytical test results should be included as an attachment to the report and summarized in the report narrative. Summary tables showing all analytical results with the dates and times of sample collection should be included in the report. All results should be traceable to the original test data. At a minimum, the test report should identify how the results were calculated (formulae and data used). Detailed sample calculations should be presented in the appendix and referenced. For example, the equation used to calculate the DRE should be provided as follows:

$$DRE = \left[ \frac{W_{in} - W_{out}}{W_{in}} \right] \times 100$$

The values or location of the values for  $W_{in}$  and  $W_{out}$  used in the calculation (e.g., the table or page number where they appear in the report) along with the calculated result should be clearly identified, so that the DRE calculation may be confirmed.

Also identify and discuss any anomalies in the system operation, sampling, monitoring, or analyses that may have significant impact on the test results. Raw data and raw analytical results (e.g., chromatograms and mass measurements) also should be presented in the appendices.

The applicant should ensure that the unit of measure is indicated for all numerical data (e.g., ppm, %, mg, mL) and is consistent throughout the test report. Also, it is suggested that samples have an easily identifiable label or naming scheme within the report. For example, a duplicate sample taken at the end of the second test run, located in the feed tank could be labeled as “Demo\_R2\_FT\_End-dup.” At minimum, the applicant should include a table correlating the sample label to the sample description.

### ***7.2.7 Test Report Section IV - Monitoring and Sampling Procedures***

This section of the report should summarize the monitoring and sampling procedures used during the test. The applicant should discuss the samples collected (type, location, time, volume, and number) and all monitoring data collected (type, location, and time period). A schematic diagram can be used to illustrate the monitoring and sampling locations. Describe any data processing that was conducted with the results, such as, data reduction or calculations.<sup>65</sup> Also, discuss the methodology used to translate the data into operating parameter ranges. Some of this information should have been discussed in the test plan (sections [5.2.6](#) and [5.2.7](#)) and may be duplicated or referenced in the test report, but any significant deviations from the approved test plan should be noted and the potential effects on the results discussed.

Any “standard methods” used should be referenced, and any deviations from standard procedures, such as modifications to the published procedures, or selection from several options given in a procedure should be described. Lengthy descriptions should be placed in an appendix. When the standard method allows different procedural variations to be used, the applicant should be specific as to the procedures that were followed (e.g., for the measurement of O<sub>2</sub> and CO<sub>2</sub> concentrations in the stack gas by EPA Method 3, whether multi-point integrated sampling or single-point grab sampling was used).

### ***7.2.8 Test Report Section V - Analytical Procedures***

The test report should summarize the analytical procedures used for each parameter (e.g., PCBs in water). Standard procedures may be referenced, but any deviations from or modifications to referenced methods should be described. Some of this information may have been discussed in the test plan (section [5.2.7](#)) and may be duplicated or referenced in the test report, but any significant deviations from the approved test plan should be noted and the potential effects on the results discussed. Lengthy descriptions of the analytical procedures should be placed in an appendix.

In some instances, the applicant may have been asked to demonstrate equivalence between a method they are requesting and a standard method or an EPA method, such as those found in SW-846 (i.e., Method 8082). If this is the case, duplicate samples should have been taken during the test and analyzed according to both methods. The applicant should present the results that compare the two methods in this section and discuss how the two methods are equivalent. The applicant should also discuss how the proposed method does not present unreasonable risk of injury to health or the environment.

---

<sup>65</sup> It may be beneficial to show one step-by-step calculation as an example if the calculation is conducted multiple times to obtain test results.

### ***7.2.9 Test Report Section VI - Quality Assurance Summary***

This section should summarize the QA results (blanks, replicates, audit results including results from performance evaluation (PE) samples). The applicant should identify any serious problems (e.g., unacceptable audit results, failure to calibrate instrumentation) or deviations from QA procedures identified in the approved test plan.

A complete QA report should be appended to the test report and address all the QA objectives, including whether precision and accuracy objectives were met, as well as results of QC samples, performance audit samples, and systems audits. This report should be authored and signed by the project's QA officer.

Additional information regarding a QAPP can be found in [section 4.2.20](#) of this guidance document. Also, other guidance documents may be helpful, such as: "Guidance for Quality Assurance Project Plans, EPA QA/G-5" (U.S. EPA, 2002) and "EPA Requirements for Quality Assurance Project Plans" (U.S. EPA, 2001). See [Appendix D](#) for a QAPP template, or contact EPA for guidance.

### ***7.2.10 Test Report Section VII - Visits and Audits***

This section should contain a list of visitors and auditors and the affiliation, address, and phone number of those who were on site during the test. The list should include all visitors or auditors from local, state, or federal agencies and their contractors, applicant management, QA personnel, and independent consultants. Where possible, the purposes of these visits should be summarized and any significant results (audit reports, engineering certifications, etc.) issued by any visitors should be appended to the test report.

### ***7.2.11 Test Report Section VIII - Waste Handling and Disposal***

The applicant should be aware that all PCB waste generated during the test should be disposed of or decontaminated in accordance with the requirements of 40 CFR part 761, subpart D. The test report should provide documentation that all wastes generated during the test were properly disposed of in accordance with the applicable requirements of TSCA and any other applicable law, such as RCRA. Copies of manifests should be included in the test report, where applicable, unless available through EPA's e-Manifest system.

### ***7.2.12 Appendices***

Supporting information should be included in the appendix. Due to the amount of information expected to be placed in the appendix, EPA suggests separating the information into multiple appendices. The applicant should clearly label multiple appendices (e.g., Appendix A – Detailed Procedures, Appendix B – Off Gas Data Sheets, Appendix C – QA Report).

Supporting information in appendices may include:

- Detailed procedures;
- Detailed analytical results;
- Other detailed data sets such as monitoring parameter logs;
- Sampling calculations;
- QA report;
- Chronological test event log;

- Incident reports;
- Chromatograms;
- Waste manifests; and
- Chain of custody record(s).

### 7.3 EPA Review of the Test Report

The approval writer will review the report to determine if it contains all the information necessary for the EPA approval writer to decide whether to issue an operating approval.

#### 7.3.1 Evaluating Test Results

When evaluating results of a test, EPA will generally consider compliance with the criteria listed in [section 4.1.2](#) (regulatory standards, performance standards, and QA/QC criteria). The criteria will be compared to the results of the test to determine whether the treatment unit performance was equivalent to disposal in a § 761.70 incinerator or a § 761.71 high efficiency boiler and will not present an unreasonable risk of injury to health or the environment, as required under § 761.60(e).

EPA will determine if regulatory standards were met during the test.<sup>66</sup> The PCB concentration for all treated effluent sources must be  $\leq 2$  ppm for all matrices (e.g., clean soil or dielectric fluid) except air and water.<sup>67</sup> Water must contain  $< 3$  ppb PCBs if discharged to treatment works or navigable waters (unless the discharge is in accordance with a PCB discharge limit included in a permit issued under the Clean Water Act) or  $\leq 0.5$  ppb PCBs for unrestricted use.<sup>68,69</sup> Air emissions must be at least 99.9999% DRE for PCBs<sup>70</sup> and additional air quality standards may apply (e.g., dioxins and furans).<sup>71</sup> An incinerator must meet all of the requirements specified in § 761.70(a) and § 761.70(b), unless a waiver is obtained pursuant to § 761.70(d)(5).

EPA will evaluate the operational performance of the treatment unit. This generally involves reviewing the monitoring and sampling test results to ensure the treatment process operated within the conditions stated within test plan. EPA will also review the monitoring and sampling data to ensure it was conducted as planned (e.g., sampling frequency). If the results are out of range or the monitoring and sampling was not conducted according to plan, then a discussion should be provided explaining the discrepancy and how it will be addressed in the future. EPA may consider this information when making a no unreasonable risk determination and may include additional conditions in the operating approval, as needed.

---

<sup>66</sup> All the regulatory standards listed here may not be applicable depending on method of treatment and disposal. For example, PCB-contaminated solids and liquids may be separated during an approved treatment process where the solids are sent to a TSCA landfill and the liquids are treated to  $\leq 2$  ppm.

<sup>67</sup> Previous guidance has interpreted that “equivalent level of performance” to an incinerator means less than or equal to 2 ppm. See “Guidelines for Permit Applications and Demonstration Test Plans for PCB Disposal by Non-Thermal Alternative Methods” (1986).

<sup>68</sup> 40 CFR 761.50(a)(3).

<sup>69</sup> 40 CFR 761.30(u)(3).

<sup>70</sup> 40 CFR 761.70(b)(1).

<sup>71</sup> These standards may be satisfied through a CAA permit instead, if applicable.

EPA will review the test report with safety considerations in mind. EPA will review any procedures or operations that may pose a risk to the workers or the local community such as buildup of an explosive/flammable compound, location of combustible materials, and exposure to PCBs or other hazardous constituents. It may be beneficial to include a discussion on how the treatment process was operated safely during the test and point out the safety considerations that will continue to be implemented during normal operations.

QA/QC data will be reviewed by EPA to determine that the accuracy, precision, and representativeness of the data have been demonstrated. This includes reviewing the supporting data, gas chromatograms, and calculations. Data from duplicate samples taken by EPA will be compared to the measured values provided by the applicant; it is expected that the data falls within 70-130% of EPA's results. Also, EPA may provide two performance evaluation (PE) samples to the applicant, which should be analyzed and presented in the test report.

EPA may take into consideration other federal and state requirements when evaluating the results, such as:

- National Historic Preservation Act (NHPA);
- Endangered Species Act (ESA);
- Environmental Justice per Presidential Executive Order 12988;
- CAA and MACT standards; and
- Other state or local requirements.

### ***7.3.2 Deficiencies in the Test Report***

EPA may request more information if sections of the report are missing, incomplete, unclear, or deficient. The process of identifying these deficiencies will vary depending on the approval writer but deficiencies will generally be identified either through email/phone calls with the applicant, or in a list compiled after reviewing the report in its entirety. If significant deficiencies are found in the report and the applicant is unclear as to how to address them, it is suggested that the applicant request a meeting or teleconference with the approval writer to help resolve any issues. EPA may deny the application if the deficiencies are not addressed within a reasonable period of time. EPA encourages the applicant to work with EPA approval writers when developing their report so that deficiencies are kept to a minimum and EPA can review the report and issue an approval in a timely matter.

**CLEAR AND COMPREHENSIVE  
REPORTING ARE KEY TO EPA'S  
ABILITY TO DO TIMELY REVIEWS  
AND APPROVALS.**

### ***7.3.3 Incomplete or Failed Test***

The applicant should still submit a test report for EPA review even if the test was incomplete or failed for any reason. After review of the test report, EPA may:

- Move forward with drafting an operating approval;
- Deny the operating approval without further consideration;
- Recommend that the applicant submit a R&D approval application to provide an opportunity to correct operating deficiencies prior to another test;
- Reschedule the test with the same test plan, which is usually done when minor deficiencies in the operating process cause the problem. The applicant would be requested to provide adequate



assurance to the approval writer that deficiencies have been corrected and subsequent test failure is unlikely, that the test would be conducted in a manner that will not present an unreasonable risk of injury to health or the environment, and that no modifications are needed to the treatment system to assure they will be in full compliance with the performance standards; or

- Reschedule the test with a new test plan, which is usually used when major design changes are needed or major operating deficiencies need to be corrected before another test can be performed. In such circumstances the facility should submit a revised test plan that reflects design or operational changes such that there is adequate assurance the treatment unit will achieve relevant performance standards. EPA will issue another test plan approval, if warranted.

## SECTION 8

### APPROVAL ISSUANCE AND RENEWAL

Upon review of the test report and a determination that the process has demonstrated compliance with all pertinent requirements of 40 CFR part 761 when operating pursuant to the proposed conditions of an operating approval, EPA may issue a final approval to operate the PCB treatment system. This section presents the general components in an approval, as well as the approval renewal and expiration processes. Note that an operating approval will not be drafted if EPA determines the facility is not able to operate in compliance with the relevant requirements in 40 CFR part 761. In this case, EPA will issue a letter to the facility containing the determination and stating that they may submit a new test plan, should the applicant choose to continue pursuing an operating approval.

#### 8.1 Public Comment and Public Participation

EPA generally provides public notice and comment opportunities on fixed-site disposal draft approvals and includes responses to public comments, where applicable, in final approvals or other supporting documentation.<sup>72</sup> Research and development (R&D) approvals generally do not involve public participation because of limitations on time and amount of material treated, however, the applicant should verify this with the EPA. Mobile treatment units are generally required as a condition of the approval to post a notice of operation where the local community could expect to see a community notice, since the location where the mobile unit will operate may not be known prior to issuance of the approval.

Draft approvals for fixed-site disposal activities are generally posted on EPA's website during the public comment period, along with additional information about the applicant and the proposed operations. During the public notice period, all documents associated with the approval should be made available to the local community. The public comment period usually lasts thirty (30) days and comments are accepted by email and mail. Additionally, a public participation meeting is often held in the community nearest the facility. This meeting serves to educate the public on the proposed operations and provide a listening session to hear community concerns. Public comments will be reviewed and considered prior to making the final decision on issuance of the final approval. If any material in the approval is CBI then a redacted version will be provided to the public during the comment period (see [section 4.1.5](#) for information on submitting CBI material to EPA).

#### 8.2 Operating Approval Contents

The primary conditions of the final operating approval will include select operating levels/ranges, the type of PCB-containing material that can be processed, an upper limit on PCB concentration in the feed, other technical requirements or conditions, and an effective period, usually between five and ten years, from the date of issuance. Note that the conditions in the operating approval are based on the parameters and operational performance observed during the test and, as a result, these conditions may differ from the conditions stated in the approved test plan. Furthermore, EPA may find it necessary to include additional requirements or conditions in the approval to ensure the treatment process will not pose an unreasonable risk of injury to health or the environment, in accordance with 40 CFR 761.60(e) and 761.70(d)(4)(ii). For example, conditions pertaining to waste disposal, emergency response, site

---

<sup>72</sup> Memo from Lynn R. Goldman to Jane Saginaw in April 1995 regarding the use of public participation in PCB commercial storage and disposal approvals.

security, recordkeeping, reporting, closure, and financial assurance may be included in the approval.

### ***8.2.1 Mobile vs. Fixed-Site Disposal Approvals***

The Director of ORCR has authority to issue multi-region approvals to mobile units and other PCB disposal methods that are used in more than one EPA Region.

Mobile units may be subject to different notification requirements than fixed-site disposal units. Prior to operating at a new location, a mobile unit will usually send non-confidential, written notifications of its intent to treat PCBs at such location to EPA Headquarters, the appropriate EPA Regional PCB coordinator, the applicable state environmental agency, and local governmental environmental entities (if applicable). In some cases, the company may need to send additional advanced notifications to local fire departments and other applicable local emergency response entities where the unit intends to operate. Public notices that state when a mobile treatment unit is operating should be made available to the local community. This may entail signs posted in public view at the facility and/or publication on the facility's website for the duration of the mobile treatment unit's operation.

**AN APPROVED MOBILE UNIT IS EXPECTED TO BE MOBILE; OPERATING FOR A SIGNIFICANT AMOUNT OF TIME AT A SINGLE SITE WILL REQUIRE A FIXED SITE APPROVAL**

If an approval is written for mobile operation of a disposal unit, but the company intends to operate the unit at a facility for more than the period of time (e.g., 60 days) set forth in their approval in any given year, the company may need to either convert the mobile approval into a fixed-site disposal approval or obtain a separate, additional fixed-site approval. If a mobile approval and a fixed-site approval are needed, then both approval processes will be coordinated between EPA Headquarters and the EPA Region where the site is located.

### ***8.2.2 Compliance under an Operating Approval***

The operating approval will describe requirements for treating PCB waste and will likely also contain recordkeeping, sampling, and notification conditions. Generally, a facility must begin operating under the approval as soon as the PCB waste is being prepared for treatment or the unit is started up for treatment of PCB waste, whichever comes first. A facility is usually required to follow the requirements of their approval until all the TSCA-regulated waste is treated, the PCB waste is stored as required by the PCB regulations, or the remaining PCB waste is sent off-site. The facility must follow all conditions of their approval at all times when PCB waste is handled and treated. In some instances, the facility may also be required to decontaminate their treatment unit following completion of treatment operations. The facility should initiate closure if, for example the operating approval is terminated, expired, or the facility will no longer be treating PCB waste. Furthermore, the facility must obtain and follow all other applicable federal, state, and local permits and regulations.

EPA reserves the right for its employees or agents to inspect approved treatment/disposal units at any reasonable time. If found to be out of compliance, EPA may:

- Suspend all PCB treatment operations until the facility addresses EPA's concerns;
- Require a modification to the operating approval;
- Require a new test;

- Terminate the operating approval; and/or
- Subject the facility to further enforcement action, including fines.

### **8.2.3 Approval Modifications**

Modifications to an existing approval can be initiated by either EPA or the facility. EPA could initiate a modification any time there is reason to believe the operation of the unit presents an unreasonable risk of injury to health or the environment. EPA-initiated modifications may result from, for example, future EPA rulemaking(s) or from new information gathered by the facility or EPA.

The facility also can initiate a major modification to the approval, for example, to increase the flow rate through the system or change the engineering design, hardware, or capacity. Major modifications initiated by the facility usually involve a test to ensure that the unit continues to operate in a manner that does not present unreasonable risk of injury to health or the environment. Tests for modifications are up to the discretion of the approval writer; for example, changes in ownership, or name changes may not necessitate a retest. To initiate a modification and inquire about a retest, the facility should contact the approval writer in writing by email or mail.

### **8.3 Approval Renewal and Expiration**

If a facility would like to continue to operate beyond the expiration date of its approval, the facility must submit a complete approval renewal application and, if required, a complete test plan to EPA in advance (usually 180 days) of the expiration date of their approval. The submission period should be specified in the approval. Generally, if the facility submits this information to EPA in accordance with the conditions of their existing approval, EPA may allow the existing approval to continue in force until EPA issues a renewed approval or an approval request denial. During this interim period, the approval is “administratively continued.” However, the facility cannot begin operating under modified conditions until EPA issues a renewed approval.

A complete approval renewal application and test plan includes, at a minimum, information that was submitted in previously approved operating approval applications and test plans, with appropriate modifications or updates based on proposed revisions to the original approval (i.e., treatment unit design and operation changes and revised operating and testing procedures). For example, if a facility is seeking approval to treat another PCB material or the same PCB-containing material at higher PCB concentrations, the approval application and test plan should reflect those changes.

EPA will generally require the facility to conduct another test to assure its operations continue in accordance with the applicable performance standards and in a manner that does not present an unreasonable risk of injury to health or the environment. As a result, the facility is encouraged to contact the EPA approval writer in advance of submitting an approval renewal application to ascertain whether a new test is needed. If the facility wants to make changes to its operating parameters, then a test is typically required. Remember that the facility will not be allowed to operate under revised operating conditions until EPA issues a fully renewed and revised operating approval. When a test is required, the approval renewal process is similar to the initial approval application process described in sections 3 through 7 of this document. Note that, if an approved facility is nearing their approval expiration date

and they have an upcoming job to treat PCBs then they may be able to use that opportunity as a demonstration test.

If no approval renewal application is submitted within the prescribed time frame, EPA will assume that the company intends to let their approval expire. Even when an approval is set to expire, the company may have obligations related to closure and should refer to their closure plan and approval. Early contact with the approval writer will help the closure process run more smoothly. Once EPA receives certification of closure (see [section 4.3.1](#)), EPA will notify the owner or operator that financial assurance is no longer required.

#### **8.4 Approval Termination**

EPA reserves the right to terminate or revoke an approval at any time. EPA may terminate or revoke an approval if there is reason to believe the operation of the unit presents an unreasonable risk of injury to health or the environment. Termination may be initiated, for example, following future EPA rulemaking(s) with respect to PCBs or new information gathered by the facility or EPA, such as observed non-compliance with the approval.

## SECTION 9

### REFERENCES

Doa, Maria J. "Memorandum: Policy Regarding Use of On-site Disposal Methods When Calculating Financial Assurance Closure Cost Estimates," Office of Prevention, Pesticides and Toxic Substances, U.S. Environmental Protection Agency, Washington, D.C., May 1, 2007.

Goldman, L. R., 1995. "Memo to Jane N. Saginaw," Office of Prevention, Pesticides and Toxic Substances, U.S. Environmental Protection Agency, Washington, D.C., April 1995.

U.S. Environmental Protection Agency, 1979. "Polychlorinated Biphenyls (PCBs) Manufacturing, Processing, Distribution in Commerce, and Use Prohibitions," Federal Register, Volume 44, pp. 31514-31568, May 31, 1979.

U.S. Environmental Protection Agency, 1986. "Draft Guidelines for Permit Applications and Demonstration Test Plans for PCB Incinerators," Office of Pollution Prevention and Toxics, Washington, D.C., May 1986.

U.S. Environmental Protection Agency, 1986. "Guidelines for Permit Applications and Demonstration Test Plans for PCB Disposal by Alternative Methods," Office of Pollution Prevention and Toxics, Washington, D.C., June 1986.

U.S. Environmental Protection Agency, 1986. "Permit Writers Guide to Test Burn Data," EPA/625/6-86/012, Office of Research and Development. Washington, D.C., September 1986.

U.S. Environmental Protection Agency, 1989. "Guidance on Setting Permit Conditions and Reporting Trial Burn Results," EPA/625/6-89/019, Office of Research and Development. Washington, D.C., January 1989.

U.S. Environmental Protection Agency, 1989. "Interim Procedures for Estimating Risks Associated with Exposures to Mixtures of Chlorinated Dibenzo-p-dioxins and -dibenzofurans (CDDs and CDFs)," EPA-SAB-EC-87-008. EPA Science Advisory Board. Washington D.C., November 1989.

U.S. Environmental Protection Agency, 1993. "Operational Parameters for Hazardous Waste Combustion Devices," EPA/625/R-93/008, Office of Research and Development. Washington, D.C., October 1993.

U.S. Environmental Protection Agency, 1998. "Disposal of Polychlorinated Biphenyls (PCBs)." [Federal Register, Volume 63, No. 124, pp. 35384-35474](#), June 29, 1998.

U.S. Environmental Protection Agency, 2001. "EPA Requirements for Quality Assurance Project Plans, EPA QA/R-5," [EPA/240/B-01/003](#), Office of Environmental Information, March 2001.

U.S. Environmental Protection Agency, 2002. "Guidance for Quality Assurance Project Plans, EPA QA/G-5," [EPA-240/R-02/009](#), Office of Environmental Information, December 2002.

**APPENDIX A**  
**SOURCES FOR ADDITIONAL INFORMATION**

See 40 CFR part 761 for more information on PCB regulations. An outline of the PCB regulations is provided in the table below.

**Table A-1. Outline of 40 CFR part 761 <sup>1</sup>**

---

Subpart A - General
761.1    Applicability
761.2    PCB concentration assumptions for use
761.3    Definitions
761.19   References
Subpart B - Manufacturing, Processing, Distribution in Commerce, and Use of PCBs and PCB Items
761.20   Prohibitions
761.30   Authorizations
761.35   Storage for Reuse
Subpart C - Marking of PCBs and PCB Items
761.40   Marking requirements
761.45   Marking formats
Subpart D - Storage and Disposal
761.50   Applicability
761.60   Disposal Requirements
(a)   PCB Liquids
(b)   PCB Articles
(c)   PCB Containers
(d)   [Reserved]
(e)   Alternative Methods
(f)   Written Notice
(g)   Testing Procedures for PCB Concentration
(h)   Export/Import for Disposal
(i)   Approval Authority for Disposal Methods
(j)   Self-implementing Requirements for R&D for PCB Disposal
761.61   PCB Remediation Waste
761.62   Disposal of PCB Bulk Product Waste
761.63   PCB Household Waste
761.64   Waste from R&D Activities
761.65   Storage for Disposal
761.70   Incineration
(a)   Liquid PCBs
(b)   Non-liquid PCBs
(c)   Maintenance of Data and Records
(d)   Approval of Incinerators
761.71   High Efficiency Boilers
761.72   Scrap Metal Recovery Ovens and Smelters
761.75   Chemical Waste Landfills
761.77   Coordinated Approval
761.79   Decontamination Standards and Procedures
Subpart E - Exemptions
Subpart F - Transboundary Shipments of PCBs for Disposal
Subpart G - PCB Spill Cleanup Policy



**Table A-1. Outline of 40 CFR 761 <sup>1</sup> (continued)**

---

Subpart J - General Records and Reports

761.180 Records and Monitoring

Subpart K - PCB Waste Disposal Records and Reports

Subpart M - Determining a PCB Concentration for Purposes of Abandonment or Disposal of Natural Gas Pipeline

Subpart N - Cleanup Site Characterization Sampling for PCB Remediation Waste in Accordance with § 761.61(a)(2)

Subpart O - Sampling to Verify Completion of Self-Implementing Cleanup and On-Site Disposal of Bulk PCB Remediation Waste and Porous Surfaces in Accordance with § 761.61(a)(6)

Subpart P - Sampling Non-Porous Surface for Measurement-Based Use, Reuse, and On-Site or Off-Site Disposal Under § 761.61(a)(6) and Determination Under § 761.79(b)(3)

Subpart Q - Self-Implementing Alternative Extraction and Chemical Analysis Procedures for Non-Liquid PCB Remediation Waste Samples

Subpart R - Sampling Non-Liquid, Non-Metal PCB Bulk Product Waste for Purposes of Characterization for PCB Disposal in Accordance with § 761.62, and Sampling PCB Remediation Waste Destined for Off-Site Disposal in Accordance with § 761.61

Subpart S - Double Wash/Rinse Method for Decontaminating Non-Porous Surfaces

Subpart T - Comparison Study for Validating a New Performance-Based Decontamination Solvent Under § 761.79(d)(4)

---

<sup>1</sup>Some subparts are outlined in greater detail than others. See <https://www.epa.gov/pcbs/learn-about-polychlorinated-biphenyls-pcbs#laws> for additional details.

The references below may be helpful for those applying for an operating approval under §§ 761.70 or 761.60(e). Note that some of the references focus on RCRA or CAA requirements. As such, elements of those compliance regimes would not be applied or required for TSCA incinerator/alternative treatment facilities unless the requirements are already specified in the PCB regulations, or the approval writer determines such additional limits are necessary to ensure the PCB treatment/disposal unit does not present an unreasonable risk of injury to health or the environment.

#### Literature - Sampling and Analytical Methods

M.D. Erickson, Analytical Chemistry of PCBs, Second Edition, CRC/Lewis Publishers, Boca Raton, FL, 1997.

The book defines and discusses sampling, extraction, cleanup, determination of PCB concentration by chromatographic and nonchromatographic methods, data reduction, and quality assurance as six discrete steps in the analysis of PCBs. The final chapter provides a discussion on collaborative testing. The comprehensive bibliography includes more than 1200 references. Five appendices detail PCB nomenclature, physical properties, compositions of commercial mixtures, mass spectra characteristics, and PGC/ECD chromatograms. The book includes extensive critical reviews of the primary literature.

---

#### Manual – PCB Inspections

U.S. Environmental Protection Agency, “Polychlorinated Biphenyl Inspection Manual,” Office of Pollution, Prevention, and Toxics, Washington, D.C., [EPA305-X-04-002](#), August 2004.

EPA developed this manual to guide inspectors in conducting inspections to ensure compliance with regulations promulgated under section 6(e) of the Toxic Substances Control Act (TSCA) pertaining to polychlorinated biphenyls (PCBs). The pertinent regulations are found at Part 761 of Title 40 of the Code of Federal Regulations (CFR). The manual gives inspectors an overview of the regulations they will use in determining compliance. EPA case development/enforcement personnel make the ultimate determination of where a violation has occurred. Appendices are provided to supplement information in the manual, including Appendices I and L that address specific disposal methods and incinerators and alternative disposal methods, respectively.

---

#### Manual - RCRA Incinerator Applications

G. Vogel, K. Brooks, I. Frankel, S. Haus, and W. Jacobsen, “Guidance Manual for Evaluating Permit Applications for the Operation of Incinerator Units,” Report by The Mitre Corporation, McLean, VA, to U.S. Environmental Protection Agency, Contract No. 68-01-6092, December 31, 1980, 221 pp.

An EPA or state approval writer is offered guidance for evaluating approval applications submitted by owners or operators of incinerator facilities as required under mandate of the Resource Conservation and Recovery Act of 1976. The subject areas requiring evaluation are

identified and information that should be contained in an application to ensure a thorough evaluation is listed. Data typical of current, acceptable incineration practices and examples of computations are offered to assist the approval writer.

---

#### Manual - Sampling and Analytical Methods

U.S. Environmental Protection Agency, 2014. "Test Methods for Evaluating Solid Waste, Physical/Chemical Methods, SW-846." Washington, D.C.: Office of Land and Emergency Management. <http://www.epa.gov/epawaste/hazard/testmethods/sw846/online/index.htm>

The SW-846 manual provides test procedures and guidance which are recommended for use in conducting the evaluations and measurements needed to comply with EPA regulations. These methods are accepted by the U.S. EPA for obtaining data to satisfy the requirements of the PCB Regulations under 40 CFR part 761.

---

#### Memo - Closure Cost Estimates

Doa, Maria J., 2007. "Policy Regarding Use of On-Site Disposal Methods When Calculating Financial Assurance Closure Cost Estimates," National Program Chemicals Division, U.S. Environmental Protection Agency, Washington, D.C., May 2007.

This memo addresses the issue of using on-site disposal methods when calculating closure cost estimates of PCB storage approvals. The memo clarifies that if a facility's on-site disposal process is proprietary, mobile, or technologically complex, then the facility cannot guarantee that its treatment process will be available for use by a third party at the time of closure. As a result, the exception at 40 CFR 761.65(f)(1)(iii) would not apply to closure cost estimates if the on-site disposal is proprietary, mobile, or technologically complex.

---

#### Memo - Public Participation

Goldman, L. R., 1995. "Memo to Jane N. Saginaw," Office of Prevention, Pesticides and Toxic Substances, U.S. Environmental Protection Agency, Washington, D.C., April 1995.

The Agency received a citizen's petition under section 21 of the Toxic Substances Control Act (TSCA). The petition requested that the Agency issue rules for public notice and comment prior to issuing PCB commercial storage approvals under 40 CFR 761.65(d) or PCB disposal approvals under 40 CFR 761.60(e).

Agency regulation, policy, and guidance requires notification of the public and inclusion of public comments, where applicable into final permit approvals (40 CFR 124.10) for public participation for permits issued under various statutes, and for PCBs (see "Guidance Manual for Writers of PCB Disposal Permits for Alternative Technologies," October 1, 1988). Since the Agency is already committed to full public participation, the Acting Director for the Office of

Pollution Prevention and Toxics decided to deny this petition. Amending the appropriate sections of 40 CFR part 124 and 40 CFR part 761 to include public participation would have used scarce resources to formalize existing Agency policy.

To ensure national uniformity and avoid additional rulemaking, staff was directed to abide by Agency requirements and include public participation in all TSCA approvals for commercial storage and fixed-site disposal activities.

---

### Authoritative Recommendations - Occupational Exposure to PCBs

Department of Health, Education, and Welfare, Public Health Service, Center for Disease Control, National Institute for Occupational Safety and Health, "Criteria for a Recommended Standard. Occupational Exposure to Polychlorinated Biphenyls (PCBs)," September 1977, 224 pp. (available from U.S. Government Printing Office, Washington, D.C.).

The National Institute for Occupational Safety and Health (NIOSH) recommends that employee exposure to polychlorinated biphenyls (PCBs) in the workplace be controlled by adherence to their guidance document. The standard is designed to protect the health and provide for the safety of employees for up to a 10-hour workday, 40-hour workweek, over a normal working lifetime. The standard is measurable by techniques that are valid, reproducible, and available to industry and governmental agencies. NIOSH concluded that compliance with the standard should substantially reduce any risk of reproductive or tumorigenic effects of PCBs and prevent other adverse effects of exposure in the workplace. Employees should regard the recommended workplace environmental limit as the upper boundary for exposure.

NIOSH found evidence that indicates adverse reproductive and tumorigenic effects in experimental animals exposed to certain commercial PCB preparations. Available information was not adequate to demonstrate that other commercial PCB preparations do not have these effects. Should sufficient information become available to indicate that the standard offers greater or lesser protection from some chlorobiphenyl isomers or commercial preparations than is needed, NIOSH will consider revising the standard.

---

### Reference Tool - Index of Sampling and Analytical Methods

U.S. Environmental Protection Agency, "Index to EPA Test Methods," U.S. EPA New England Region 1 Library, Boston, MA, April 2003. <http://www.epa.gov/region01/oarm/testmeth.pdf>.

To respond to frequent requests for agency test methods, Region 1 library staff developed a methods index as a tool to help locate copies. Confirming that there was no one volume containing all Agency methods and no comprehensive list of them, the project commenced and in 1988 the first printed Index to EPA Test Methods published as [EPA 901/3-88-001](#). It has been updated periodically to reflect new procedures and revoked methods and the current edition includes about 1600 method references. The index includes only EPA methods and its primary goal remains as a reference tool to identify a source from which the actual method can be

obtained, either free or for a fee. Note that not all EPA Test Methods related to PCBs may be applicable to incinerators and alternative technologies.

---

#### Report - Implementation of PCB Regulations

R.G. McInnes and R. J. Johnson, "Provision of Technical Assistance to Support Regional Office Implementation of the PCB Regulations - East and West," Draft Project Summary Report by GCA Corporation, New Bedford, MA, and TRW, Inc. Redondo Beach, CA, on EPA Contract No. 68-02-3168, Work Assignment No. 45, and Contract No. 68-02-3174, Work Assignment No. 68, for David C. Sanchez, U.S. EPA, Office of Research and Development, Industrial Environmental Research Laboratory, Research Triangle Park, NC, 1982, 186 pp.

This project report documents the work efforts conducted by GCA/Technology Division and TRW Environmental Division in supporting Regional office implementation of the PCB regulations, by providing regular bimonthly liaison with the EPA Regional offices and by providing technical and coordinative assistance on an as-needed basis. The bimonthly contact resulted in a regular bimonthly newsletter which was mailed to the EPA personnel in all ten Regions who were directly involved with the implementation of the PCB regulations. The technical assistance effort produced a series of individual facility evaluations as well as a separate study regarding alternative definitions of PCB solid/liquid wastes.

The salient points of the two project tasks are discussed in the body of the report and copies of a bimonthly report and all facility evaluations are included in the appendices. This report covers the period of April 28 to December 15, 1981, and work was completed as of December 31, 1981.

---

#### Report - Production, Use, and Distribution of PCBs

R. L. Durfee, G. Contos, F. D. Whitmore, J. D. Barden, E. E. Hackman, III, and R. A. Westin, "PCBs in the United States - Industrial Use and Environmental Distributions," U.S. Environmental Protection Agency, Office of Toxic Substances, Washington, DC, Report No. [EPA 560/676-005](#), [National Technical Information Service (NTIS) No. PB-252012], 1976, 488 pp.

This document presents the current state of knowledge about the production, usage, and distribution of polychlorinated biphenyls (PCBs) in the United States. The information presented is derived from detailed studies on the production and first tier user industries, the past and present generation and disposition of PCB-containing wastes, environmental transport and cumulative loads, potential alternatives to PCBs usage, inadvertent losses to and potential formation in the environment, and current regulatory authorities for PCBs control. These results indicated that, although PCBs content of industrial wastes can be reduced through various approaches (treatment, substitution, etc.), there exists a potentially severe future hazard in the form of large amounts of PCBs currently contained in land disposal sites. Further definition of this and other aspects of the PCBs problem, and determination of ways to minimize the hazard, are recommended.

---

## Report – Thermal (Boilers)

R. G. McInnes, “Technical Assistance in Support of Permitting Activities for the Thermal Destruction of PCBs,” U.S. Environmental Protection Agency, Office of Research and Development, Industrial Environmental Research Laboratory (IERL), Research Triangle Park, NC, EPA 600/2-81-240, 1982, 70 pp. (NTIS No. PB82 231 325).

This report describes phased efforts to identify, evaluate, and provide technical approval assistance to utility boiler owners considering thermally destroying PCB-contaminated mineral oil. Identification initially concentrated on identifying ideal PCB destruction sites using size, age, location, and fuel use criteria to evaluate available boilers. This effort then extended to directly contacting U.S. EPA Regional offices to identify utility boiler owners who had expressed an interest in the PCB disposal program. Regular bimonthly contacts were initiated with the Regional offices and the status of all Regional PCB activities was tracked. This contact produced three potential PCB burn sites operated by: (1) Consolidated Edison of New York, (2) Northeast Utilities, and (3) Pennsylvania Power and Light. Test plans were received from the first two and were reviewed and found acceptable; these facilities, however, subsequently withdrew their involvement with the PCB destruction verification burn program due to local community opposition. By the end of the technical performance period of this work assignment, a candidate site had not been identified or approved for testing. Appendices to this report detail the utility boiler site selection methodology, the status of PCB activities in EPA Regional offices as of May 1, 1981, and the test plan evaluations for the Consolidated Edison and Northeast Utilities facilities.

The project also required that state and local governments be provided information needed to aid approval of a PCB verification burn. Under this phase of the project a PCB “white paper” was prepared which summarized background technical information used in writing the PCB regulations (40 CFR part 761). A second paper was prepared summarizing comments delivered at a public meeting entitled “What Should We Be Doing About PCBs?” Both papers are provided as appendices to the report.

---

## Report - Thermal and Non-Thermal

D.G. Ackerman, L. L. Scinto, P. S. Bakshi, R. G. Delumyea, R. J. Johnson, G. Richard, A. M. Takata, and E. M. Sworzyn, “Destruction and Disposal of PCBs by Thermal and Non-Thermal Methods,” Noyes Data Corporation, Park Ridge, NJ, 1983, 417 pp.

This is a verbatim combination of two EPA reports:

1. Sworzyn and Ackerman (1982) [[EPA-600/2-82-069](#)], and
2. Ackerman et al., (1981) [[EPA-600/2-81-022](#)].

This report is a resource and guidance document intended to aid EPA Regional offices in applying the PCB Disposal Regulations to requests for approval of thermal destruction of PCBs.

As background material, this document describes fundamental processes of combustion, thermal destruction systems, sampling and analysis methodology, and flame chemistry relative to PCB incineration. Administrative considerations, including public involvement, are discussed. Detailed guidance on evaluation of Annex I incinerators, high efficiency boilers, and the several stages of the approval process are presented and discussed.

---

### Report – Toxicological Profile for PCBs

Agency for Toxic Substances and Disease Registry, “Toxicological Profile for Polychlorinated Biphenyls (PCBs),” and “Addendum to the Toxicological Profile for Polychlorinated Biphenyls,” U.S. Department of Health and Human Services, Atlanta, GA, [November 2000](#) and [April 2011](#), respectively.

The Agency for Toxic Substances and Disease Registry (ATSDR)’s toxicological profile succinctly characterizes toxicologic and adverse health effects information for PCBs. The peer-reviewed profile identifies and reviews the key literature that describes the properties of PCBs. Other pertinent literature also is presented. The focus of the profile is on health and toxicologic information; therefore, the profile begins with a public health statement that describes, in nontechnical language, the relevant toxicological properties of PCBs. Following the public health statement is information concerning levels of significant human exposure and significant health effects. In addition, information concerning available analytical methods for various matrices is provided, along with a listing of regulations and advisories related to PCBs.

---

### Research Report - Analytical Methods for PCB By-Products

M. D. Erickson, J. S. Stanley, G. Radolovich, K. Turman, K. Bauer, J. Onstot, D. Rose, and N. Wickham, “Analytical Methods for By-Product PCBs--Initial Validation and Interim Protocols,” Report by Midwest Research Institute, Kansas City, MO, to David P. Redford, U.S. Environmental Protection Agency, Office of Toxic Substances., Field Studies Branch, Washington, DC, [EPA-560/5-82-006](#), 1982, 243 pp.

This document presents proposed analytical methods for analysis of by-product PCBs in commercial products, product waste streams, wastewaters, and air. The analytical method for commercial products and product waste streams consists of a flexible approach for extraction and cleanup of particular matrices. The <sup>13</sup>C-labeled PCB surrogates are added as part of a strong quality assurance program to determine levels of recovery. The wastewater method is based on EPA Methods 608 and 625 with revisions to include use of the <sup>13</sup>C-labeled PCB surrogates. The air method is a revision of a proposed EPA method for the collection and analysis of PCBs in air and combustion gas emissions. Capillary or packed column gas chromatography/electron impact ionization mass spectrometry is proposed as the primary instrumental method. Response factors and retention times of 77 PCB congeners relative to tetrachlorobiphenyl-d<sub>6</sub> are presented in

addition to statistical analysis to project validity of the data and extrapolation of relative response factors to all 209 possible congeners. Preliminary studies using the <sup>13</sup>C-labeled surrogates to validate specific cleanup procedures and to analyze several commercial products and product wastes indicate that the proposed analytical methods are both feasible and practical.

---

### Research Report - Sampling and Analytical Methods

C. L. Haile and E. Baladi, "Methods for Determining the Polychlorinated Biphenyl Emissions from Incineration and Capacitor and Transformer Filling Plants," Report by Midwest Research Institute, Kansas City, MO, to Environmental Monitoring and Support Laboratory, Office of, Research and Development, U.S. Environmental Protection Agency, Research Triangle Park, NC, [EPA-600/4-77-048](#), 1977, 90 pp. (NTIS No. PB-276 745/761).

This document describes methods to measure the polychlorinated biphenyl (PCB) emissions from the stacks of municipal waste, industrial waste, and sewage sludge incinerators and from capacitor and transformer filling plants. The PCB emissions from the incineration plants are collected by impingement in water and adsorption on Florisil. The samples are extracted with hexane, concentrated through evaporation of the solvent, perchlorinated, and the polychlorinated biphenyl content measured as the decachlorinated isomer using a gas chromatograph equipped with a flame ionization detector. The PCB emissions from the capacitor and transformer filling plants are collected directly on Florisil, extracted with hexane, and quantified against the appropriate Aroclor using a gas chromatograph. The methods were developed from laboratory studies and field tested at nine incineration plants and two transformer filling plants.

---

### Review - PCB By-Products

N. D. Erickson and J. S. Stanley, "Methods of Analysis for By-Product PCBs Literature Review and Preliminary Recommendations," Report by Midwest Research Institute, Kansas City, MO, to David P. Redford, U.S. Environmental Protection Agency, Office of Toxic Substances, Field Studies Branch, Washington, DC, EPA-560/5-82-005, 1982, 135 pp.

A review of the literature on polychlorinated biphenyl (PCB) analysis and recommendations for methods to determine by-product PCBs in commercial products and other matrices are presented. This report was prepared by an EPA contractor to assist EPA in formulating a rule regulating by-product PCBs. The published literature on PCB analysis is critically reviewed. Several hundred references are cited in a bibliography. The review is subdivided into extraction, cleanup, determination, data reduction, confirmation, screening, quality assurance, and by-product analysis sections. The determination section includes thin layer chromatography (TLC), high performance liquid chromatography (HPLC), gas chromatography (GC), packed column gas chromatography (PGC), capillary gas chromatography (CGC), electron impact mass spectrometry (ECD), flame ionization detector (FID), electron impact mass spectrometry (EIMS), mass spectrometry (MS) nuclear magnetic resonance (NMR), infrared (IR), electrochemistry, neutron activation analysis (NAA), radioimmunoassay (RIA). Techniques



applicable to analysis of commercial products, air, and water for by-product PCBs are discussed. The final section of this report presents a recommended overall primary analytical scheme.

---

#### Review – Thermal and Non-Thermal

M.S.M. Mujeebur Rahuman, Luigi Pistone, Ferruccio Trifirò and Stanislav Miertus, “Destruction Technologies for Polychlorinated Biphenyls (PCBs),” published in the *Proceedings of Expert Group Meetings on POPs and Pesticides Contamination: Remediation Technologies (April 2000) and on Clean Technologies for the Reduction and Elimination of POPs (May 2000)*. [http://www.clu-in.org/download/remed/destruct\\_tech.pdf](http://www.clu-in.org/download/remed/destruct_tech.pdf)

Although the production of PCBs has been banned (excluded manufacturing products and inadvertently produced PCBs are not included in this ban) all over the world for many years, as PCBs were and, in many instances, still are used as dielectric fluids and for other industrial uses, their presence in anthropogenic products/equipment/appliances and their dispersion in the environment is still relevant. This document contains a non-exhaustive review of destruction technologies for polychlorinated biphenyls (PCBs). The analysis considers the need for criteria in assessing performance of already developed PCB destruction technologies and, when necessary, optimizing or boosting the development of innovative processes.

---

#### Review –PCB Remediation Technologies

Lyons, T., D. W. Grosse, and R. A. Parker. Engineering Issue: Technology Alternatives for the Remediation of PCB Contaminated Soils and Sediments. U.S. Environmental Protection Agency, Washington, DC, EPA/600/S-13/079, 2013.

This Engineering Issue paper provides an overview of PCB contamination and remediation, and was developed from peer reviewed literature, scientific documents, EPA reports, web site sources, input from experts in the field, and other pertinent information.

**APPENDIX B**  
**CHECKLISTS FOR COMPLETENESS OF SUBMITTAL**

**Disclaimer:** The checklists in Appendix B describe information that EPA suggests be included in the approval application or test plan. This is based on EPA's experience with previous operating approvals at facilities with various levels of complexity. Depending on site-specific circumstances, certain information on the checklist may not be applicable.

The checklists in Appendix B are not a substitute for the regulatory requirements in 40 CFR part 761, including 40 CFR 761.60(e) or 761.70. Additionally, these checklists are not required to be used or submitted to EPA. Treatment operators and site owners are responsible for complying with all applicable requirements in 40 CFR part 761. In case of conflict between this document or portion(s) thereof and any PCB regulatory requirement, the TSCA PCB regulations supersede this document.

DISCLAIMER: THIS IS ONLY AN EXAMPLE TEMPLATE AND MAY NOT CONTAIN ALL REQUIREMENTS THAT APPLY. FURTHERMORE, APPLICANTS ARE NOT REQUIRED TO USE THIS TEMPLATE OR SUBMIT IT TO EPA.

**Table B-1. Example Approval Application Checklist for Thermal and Non-Thermal Methods**

Item	Submitted	To Be Submitted at Later Date <sup>1</sup>	Not Applicable
Approval Cover			
Section I – Summary			
Section II – Company Organization			
A. Organizational Chart			
B. Organization Description			
Section III - Waste Description			
A. Type			
B. Total Amount			
C. Physical/Chemical Description			
Section IV - Process Engineering			
A. General Overview			
1. Description			
2. Flow Diagram			
3. Location			
4. Site Maps			
B. Waste Feed System/Feed Rate			
C. Waste Feed Shut-Off System			
D. Destruction System			
E. Pollution Control System			
F. Operating Parameters			
Section V - Monitoring and Sampling Plan			
A. Parameter List			
B. Sampling/Monitoring Frequency			
C. Monitoring Plan Design			
D. Methods			
1. Monitoring			
2. Sampling			
3. Analytical			
E. Equipment			
1. Monitoring			
2. Sampling			
3. Analytical			
Section VI - Process Procedures			
A. Appropriate Methods			
B. Written Protocols			
C. Apparatus			
D. Data Reduction			
E. Data Storage/Logging			
F. Calibration			
G. Maintenance			
Section VII - Sampling and Analysis Procedures			
A. Appropriate Methods			
B. Written Protocols			
C. Apparatus			

DISCLAIMER: THIS IS ONLY AN EXAMPLE TEMPLATE AND MAY NOT CONTAIN ALL REQUIREMENTS THAT APPLY. FURTHERMORE, APPLICANTS ARE NOT REQUIRED TO USE THIS TEMPLATE OR SUBMIT IT TO EPA.

Item	Submitted	To Be Submitted at Later Date <sup>1</sup>	Not Applicable
D. Data Reduction			
E. Data Storage/Logging			
F. Calibration			
G. Maintenance			
Section VIII - Data Reporting/Recordkeeping			
A. Format			
B. Example Calculations			
C. Units			
Section IX - Waste Handling and Disposal			
A. List of All Wastes (type and amounts)			
B. Disposal Methods			
Section X - Inspection Procedures			
A. Waste Feed System			
B. Destruction System			
C. Waste Feed Cutoff System			
D. Pollution Control System			
E. Alarms			
F. Fire Extinguisher Systems			
Section XI - Spill Prevention, Control, and Countermeasure			
Section XII - Safety Plan			
Section XIII - Training Plan			
Section XIV –Test Plan Summary			
A. Tentative Date			
B. Tentative Location			
C. Parameters to be Tested			
D. Waste Type			
Section XV - Test Data or Engineering Performance Calculations			
Section XVI - Other Permits or Approvals			
A. Regional R&D			
B. Regional Full-Scale			
C. RCRA			
D. State and Local			
E. DOT			
Section XVII - Schedule of Pre-Operation Events			
Section XVIII – Quality Assurance Project Plan (QAPP)			
A. Format			
B. Organization and Responsibility			
C. QA Objectives			
1. Precision			
2. Accuracy			
3. Completeness			
4. Representativeness			
5. Comparability			
D. Monitoring Procedures			
E. Sampling Procedures			
F. Analytical Procedures			
G. Sample Custody			
H. Calibration Procedures and Frequency			

DISCLAIMER: THIS IS ONLY AN EXAMPLE TEMPLATE AND MAY NOT CONTAIN ALL REQUIREMENTS THAT APPLY. FURTHERMORE, APPLICANTS ARE NOT REQUIRED TO USE THIS TEMPLATE OR SUBMIT IT TO EPA.

Item	Submitted	To Be Submitted at Later Date <sup>1</sup>	Not Applicable
I. Data Reduction, Validation, and Reporting			
J. Internal Quality Control Checks			
K. Audits			
1. Performance			
2. System			
L. Preventative Maintenance			
M. Specific Routine Procedures Used to Assess Data Precision, Accuracy, and Completeness			
N. Corrective Action			
O. Quality Assurance Report to Management			
Section XIX - Standard Operating Procedures (SOPs)			
Section XX - Closure Plan, Closure Cost Estimate & Financial Assurance			
A. Site-to-Site (Mobile)			
B. Permanent			
Approved OMB No. 2070-0211			

<sup>1</sup>Identify sections of the approval to be submitted at a later date and note any missing sections in the application.

DISCLAIMER: THIS IS ONLY AN EXAMPLE TEMPLATE AND MAY NOT CONTAIN ALL REQUIREMENTS THAT APPLY. FURTHERMORE, APPLICANTS ARE NOT REQUIRED TO USE THIS TEMPLATE OR SUBMIT IT TO EPA.

**Table B-2. Example Checklist for a Test Plan**

Item	Submitted	To Be Submitted at Later Date <sup>1</sup>	Not Applicable
Test Plan Cover			
Section I – Summary			
Section II - Company Organization			
A. Key Personnel Identified			
B. Organization Chart			
Section III - Process Engineering Information (new information from Approval Applications)			
Section IV - Process Operation Test Parameters			
A. Operational Plan			
B. Process Operating Parameters			
C. Anticipated Emission Levels			
D. Waste Feed Description/Quantity			
Section V - Monitoring and Sampling Plan			
A. Number of Tests			
B. Parameters to be Monitored			
C. Parameters to be Sampled			
D. Sampling/Monitoring Locations			
E. Number/Frequency of Samples			
F. Sampling Methods			
G. Monitoring Methods			
H. Analysis Methods			
Section VI - Process Procedures			
A. Written Protocol			
B. Equipment			
C. Calibration			
Section VII - Sampling and Analysis Procedures			
A. Methods			
B. Written Protocol			
C. Equipment			
D. Calibration			
Section VIII - Data Reporting			
A. Data to be Reported, Units			
B. Example Calculations			
Section IX - Miscellaneous Tests			
A. Automatic Waste Feed Cutoff			
B. Alarm Systems			
C. Fire System			
Section X - Waste Handling and Disposal			
Section XI - Test Schedule			
Section XII - Addenda to Quality Assurance Project Plan (QAPP)			
Section XIII - Addenda to Standard Operating Procedures (SOPs)			

Approved OMB No. 2070-0211

<sup>1</sup>Identify sections of the approval to be submitted at a later date and note any missing sections in the application.

DISCLAIMER: THIS IS ONLY AN EXAMPLE TEMPLATE AND MAY NOT CONTAIN ALL REQUIREMENTS THAT APPLY. FURTHERMORE, APPLICANTS ARE NOT REQUIRED TO USE THIS TEMPLATE OR SUBMIT IT TO EPA.

**Table B-3. Example Monitoring and Sampling Parameter Summary to be included in Test Plans for Incinerators or Alternative Thermal Destruction Processes<sup>1,2</sup>**

Parameter	To Be Sampled (Y/N)	To Be Monitored (Y/N)	Sampling Frequency	Sampling/Monitoring Location	Method	Written Protocol	Apparatus/Equipment	Analytical Method	Calibration	Data Reduction	Data Storage	Data Reporting
PCBs in Waste Feed												
Feed Composition												
Waste Feed Rate												
O <sub>2</sub>												
CO												
CO <sub>2</sub>												
NO <sub>x</sub>												
Combustion Efficiency												
Residence Time												
Destruction Temperature												
Excess O <sub>2</sub>												
HCl Removal Efficiency												
Stack Gas Flow Rate												
PCB Feed Rate												
PCB Output Rate												
DRE												
Particulate												
RCI (volatile)												
RCI (semi-volatile)												
PCDDs/PCDFs												
Semi-volatile Organic Screen												
Pollution Control System Operation												
Ash Composition												
Wastewater												
Other												

Approved OMB No. 2070-0211

<sup>1</sup>This is not an exhaustive list; EPA, at its discretion, may require additional parameters depending on the process.

<sup>2</sup>This is not intended to be a checklist; some columns may need to be edited to allow for writing in text.



DISCLAIMER: THIS IS ONLY AN EXAMPLE TEMPLATE AND MAY NOT CONTAIN ALL REQUIREMENTS THAT APPLY. FURTHERMORE, APPLICANTS ARE NOT REQUIRED TO USE THIS TEMPLATE OR SUBMIT IT TO EPA.

**Table B-4. Example Monitoring and Sampling Parameter Supplement for an Alternative Non-Thermal Technology<sup>1,2</sup>**

Parameter	To Be Sampled (Y/N)	To Be Monitored (Y/N)	Monitoring Frequency	Sampling Frequency	Monitoring/Sampling Design	Method	Written Protocol	Apparatus	Analytical Method	Data Reduction/Storage	Calibration	Maintenance
PCBs in Waste Feed												
Feed Composition												
Waste Feed Rate												
Reagent Feed Rate												
Reaction Temperature												
Reaction Pressure												
pH of Product												
Residual Reagent in Product												
PCB Concentration in Product												
PCBs in Aqueous Effluents												
PCBs in Other Wastes												
PCBs in Air Emissions												
Pollution Control System Operation												
Other												

Approved OMB No. 2070-0211

<sup>1</sup>This is not an exhaustive list; EPA, at its discretion, may require additional parameters depending on the process.

<sup>2</sup>This is not intended to be a checklist; some columns may need to be edited to allow for writing in text.

**APPENDIX C**  
**MONITORING, SAMPLING, AND ANALYSIS PROCEDURES**

This appendix summarizes **suggested** monitoring, sampling, and analysis methods for various sample matrices, including those found in feed materials and final products or effluent streams. The methods discussed in this section are not required to be used unless specified in the PCB regulations or by the approval writer in order to make a no unreasonable risk determination. Also, there may be other applicable methods that are not discussed in this section.

### **C.1 Monitoring Methods**

Monitoring of gaseous components is specifically required by 40 CFR 761.70 for thermal destruction systems. For thermal destruction units, CO<sub>2</sub> from combustion products and incineration operations must be monitored periodically at intervals set by the approval writer at either HQ or the Regions. O<sub>2</sub> and CO must be monitored continuously; however, “continuously” is not defined by the regulation. Other monitoring parameters may be required as stated in § 761.70, or as needed to demonstrate a level of performance equivalent to an incinerator under § 761.60(e).

Information related to continuous emission monitoring systems, in general, can be found in “Continuous Emission Monitoring Systems for Non-Criteria Pollutants” ([U.S. EPA, 1997](#)). Applicants may find it helpful to consult 40 CFR part 63 subpart EEE “National Emission Standards for Hazardous Air Pollutants from Hazardous Waste Combustors” when designing a monitoring plan.

### **C.2 Sampling Plans**

Inadequate sampling can ruin an otherwise acceptable test, and sampling often is the weakest portion of an application. The applicant and EPA reviewer should work together to develop a detailed sampling plan that will generate the desired information. In some cases, a “typical” sample may be desired, while in others a “worst-case” or “most challenging” sample may be desired. The objective should be clearly spelled out in a sampling plan.

PCB disposal facilities are not ideal sampling sites. Events do not always occur according to plan, especially during the shakedown periods in which the test generally is held. The sampling plan should reflect the realities of the disposal unit and be written in such a way as to allow the applicant to make every attempt to meet the stated objectives. The plan should propose acceptable alternatives to the optimum samples. In cases where a sampling plan is compromised, the test report should present an explanation.

Several examples of approaches (not full sampling plans) to sampling situations are presented below.

- Stack testing generally is conducted over the duration of a test burn (e.g., 4 hours). In the EPA Method 5 protocol, the probe is traversed across the stack in a prescribed, nonrandom manner to get a sample representative of all of the stack gases.
- The waste feed should be sampled from a pipe throughout a test burn. Ideally, a pump would be used to continuously draw off a portion of the feed to obtain an integrated sample. If use of a pump is impractical because of the valve design or feed stock viscosity, manual integration may be an alternative. If manual sampling is employed, the valve should be opened at measured time intervals (e.g., every 15 minutes), and a measured amount added to the sample. Thus, a sample would be collected over the burn duration, which would be an integration of the feed at 15-minute intervals.

- Ideally, an ash bin would be sampled in a random fashion, where every part of the bin has a finite, known probability of being sampled. However, access ports are not randomly placed. A plan may specify that the sampling be randomized within the access area available (perhaps similar to the feed sampling).
- A chemical dechlorination system should be demonstrated. The batch process vessel should be filled from numerous drums. The process vessel should be filled and the mixer activated. After 30 minutes of mixing, a sample should be drawn from the vessel tap; a second sample should be drawn 10 minutes later.
- A field of waste drums should be sampled. The drums could be randomly sampled. If the drums are known to be from several sources and are identifiable, the sampling design should include stratification of the subsets.
- The plan should stipulate that if a bung on a drum is frozen, the sampler is to move to the nearest drum to the north. If more than half of the bungs are frozen, or if the bungs on an apparent set of drums (in one area or with similar markings) are all frozen, the representativeness of the sampling may be compromised (these may all contain a corrosive liquid which has frozen the drums shut), and additional efforts at opening the drums should be employed. These efforts might include freeing the frozen bungs in the drum.

### **C.3 Sample Collection Techniques**

Guidance on sample collection techniques is available in 40 CFR part 60, Appendix A and 40 CFR part 261, Appendix I. Additional information on sample collection techniques can be found in “Samplers and Sampling Procedures for Hazardous Waste Streams” (U.S. EPA, 1980) and “Sampling and Analysis Methods for Hazardous Waste Combustion” (U.S. EPA, 1984a).

#### ***C.3.1 Liquids***

Liquids may be collected by grab or integrative techniques. Grab sampling may include filling a jar from a spigot or using an Alpha bottle to collect a water sample from a lagoon. Frequency of sampling and amount to be collected during each test should be stated in the sampling plan and recorded when the samples are collected. Integrative sampling entails a pump on an interval timer, a slow flow from a valve, manually timed interval sampling, or other integrating technique. Additional guidance is available in U.S. EPA’s guidance document entitled “Handbook for Sampling and Sample Preservation of Water and Wastewater” (U.S. EPA, 1982a).

#### ***C.3.2 Solids***

Solid sampling techniques vary with the nature of the solid. Free-flowing powders may behave like a liquid, while special equipment may be needed to remove a portion of other solids. The equipment to be used (trowel, auger, grain thief, etc.) and procedures for use should be adequately described in the sampling plan.

#### ***C.3.3 Mixed-Phase Samples***

Mixed-phase samples represent a challenge to the sample collector. In tanks and other static systems, phase separation during sampling is preferable, provided that the total volume or weight of each phase is measured. Phases collected separately should be analyzed separately. Proportions of each phase in the system (e.g., in a holding tank) should be measured volumetrically. Examples include skimming solids

off liquids and drawing off oil and water layers from a tank. Where phase separation is impractical, such as with a suspended solid, the whole system should be mixed to assure that the sample is representative. In a flowing pipe, collecting a representative sample of a solid/oil/water mixture may be impossible, because the valve position is fixed. In this situation, the oil phase probably would contain more PCBs than the water and should be sampled, as it would represent a maximum concentration (worst case for waste, best case for feed). The representativeness or lack thereof should be noted.

#### ***C.3.4 Particulate Matter in Stack Gas Emissions***

EPA Method 5 (Appendix A-3 of 40 CFR part 60) and other methods derived from Method 5 may be used to collect a particulate matter sample from the stack gas emissions.

#### ***C.3.5 Organic Stack Gas Emissions***

SW-846 Method 0023A (U.S. EPA, 1996) provides a sampling procedure that can be used for determining stack emissions of PCDDs and PCDFs from stationary sources. This method may be modified as specified by the method, to allow simultaneous sampling and analysis for PCDDs, PCDFs, PCBs, polycyclic aromatic hydrocarbons (PAHs), and semi-volatile organic compounds (SVOCs).

Gaseous and particulate samples are isokinetically withdrawn from the emission source and collected in a modified EPA Method 5 sampling train (SW-846 Method 0010). The collection components consist of the front half glassware surfaces (nozzle, probe, and front half filter holder), the glass fiber filter, the back half glassware surfaces (back half filter holder and condenser coil), and the solid sorbent (XAD-2<sup>®</sup>) module. Field sample recovery and laboratory sample preparation steps determine whether Method 0023A can be modified to provide simultaneous determination of PCBs, PCDDs, PCDFs, and SVOCs emissions. Method 0023A specifies sequential acetone, methylene chloride, and toluene rinses of the front half and back half portions of the sampling train to recover the train, with all of the solvents combined in one container for the front half rinse and another for the back half rinse. If PCBs and SVOCs are being determined simultaneously with the PCDDs and PCDFs, it is appropriate to separate the toluene rinse from the acetone and methylene chloride rinses because PCBs and SVOCs could be lost in subsequent laboratory sample preparation steps. Additional information on the combined measurement techniques for PCBs, PCDDs, PCDFs, and SVOCs can be found in Appendix B of U.S. EPA's guidance document entitled Risk Burn Guidance for Hazardous Waste Combustion Facilities (U.S. EPA, 2001).

SW-846 Method 23 (U.S. EPA, 2017) provides a sampling procedure that is very similar to Method 0023A for determining stack emissions of PCDDs and PCDFs from stationary sources. The primary difference between Method 23 and Method 0023A is that Method 0023A requires the front half of the sampling train (nozzle, probe, front half of the filter holder, and filter) to be extracted and analyzed separately from the back half of the sampling train (back half of the filter holder and condenser coil). Whereas, in Method 23 the front half and back half of the sampling train can be extracted and analyzed together.

#### ***C.3.6 HCl Stack Gas Emissions***

EPA Method 26A (40 CFR part 60, Appendix A) is used to quantify HCl emissions. A modified Method 5 sampling train as specified by EPA Method 26A, is used with an acidic (sulfuric acid) solution in the first three impingers to solubilize the HCl to form chloride. The chloride recovered from the first three impingers is then measured by ion chromatography.

### **C.3.7 NO<sub>x</sub> Stack Gas Emissions**

Nitrogen oxides (NO<sub>x</sub>) in stack gases are determined according to EPA Method 7 (40 CFR 60, Appendix A). Alternate methods, such as instrumental analyzers, may be used if approved by EPA.

### **C.3.8 RCI**

Total chlorinated organics (RCI) should be sampled during the initial destruction test. No specific method is mandated by EPA in the regulations. As a result, many sampling techniques have been used to measure RCI. Strictly speaking, an RCI test method should measure volatile, semi-volatile, and nonvolatile compounds because the collection and analysis techniques for these three categories may differ. Volatile RCI can be sampled using the Volatile Organic Sampling Train (VOST). The VOST is a combination of sampling and analytical methods from the SW-846 Compendium (U.S. EPA, 2012). Sample collection is performed using either Method 0030 or 0031, desorption of the sorbent cartridges is performed using Method 5041A, and analysis is achieved via GC with mass spectrometry (MS) (SW-846 Method 8260). Semi-volatile RCI can be determined from the sampling procedures previously described in Section C.3.5.

## **C.4 Sample Analysis Methods**

For many alternative technologies, the PCB content of the feed, product, and waste samples should be determined. This section addresses the analysis of these matrices for PCBs. As discussed elsewhere in this document, EPA may require additional analyses to demonstrate that an alternative technology has a level of performance equivalent to an incinerator approved under § 761.70. The applicant is responsible for presenting detailed methods for these matrices, other matrices, or non-PCB analyses, as required.

PCBs are a complex set of 209 individual chemical compounds. The commercial mixtures for those commonly found in the feed material generally contain from 20 to 100 of these 209 PCB congeners. In most cases for final products or effluent samples, however, it can be anticipated that the PCB pattern will be qualitatively different from that in the feed, unless the PCBs were transmitted through the system without any chemical alteration by the destruction/removal process. For effluent samples, the analytical method should identify and quantitate all of the PCBs present in each sample, not just the Aroclors present in the feed.

### **C.4.1 Methods for PCBs**

This section presents analytical methods for PCBs that should provide acceptable data, please see [Appendix E](#) of this guidance for additional information on analytical methods. This section addresses PCB analytical methods for feed material, stack gas, ash, scrubber water, and final products and effluent samples. Methods other than those presented here may be proposed by applicants, but EPA will evaluate the proposed methods' adherence to data quality objectives (e.g., analysis for all PCBs in samples with quantitation limits adequate to meet approval requirements). Applicants should review this guidance and propose specific extraction, cleanup, and analysis methods in their test plan. Many methods, including some of those discussed in this section, present one or more options to the analyst. If there is more than one option, the applicant should state which option is to be used and present the selection criteria in the test plan. Additional guidance on analytical methods for PCBs is available (Erickson, 1997).

**Table C-1. Summary of Standard Stack Sampling/Monitoring Methods**

<b>Method</b>	<b>Application</b>	<b>Description</b>
SW-846 Method 0010	PCBs and semi-volatiles in stack gas emissions	Samples of gaseous and particulate pollutants are withdrawn from an emission source at an isokinetic sampling rate and are collected in a multicomponent sampling train. Principal components of the train include a high-efficiency glass- or quartz-fiber filter and a packed bed of porous polymeric adsorbent resin. The filter is used to collect organic-laden particulate materials and the porous polymeric resin is used to adsorb semi-volatile organic species. Semi-volatile species are defined as compounds with boiling points > 100 °C. Comprehensive chemical analyses of the collected sample are conducted to determine the concentration and identity of the organic materials.
SW-846 Method 0020	Semi-volatiles and particulates in stack gas emissions	Samples of particulate and semi-volatile organic materials are withdrawn from a source at a constant rate near isokinetic conditions and are collected in a multicomponent sampling train. Chemical analyses of the samples are conducted to determine the concentration and identity of the semi-volatile organic species and gravimetric determinations are performed to approximate particulate emissions.
EPA SW-846 Method 23 or 0023A	Dioxin/Furan	This method describes the sampling procedure to be used for determining stack emissions of polychlorinated dibenzo-p-dioxins (PCDDs) and polychlorinated dibenzofurans (PCDFs) from stationary sources. Note that, dioxins and furans may be formed during destruction of PCBs in temperature ranges 450 to 750 °F
EPA SW-846 Method 0031	Volatile Organics	This method is used to determine volatile organic compounds in gaseous emissions from a wide variety of stationary sources including hazardous waste incinerators. Note that, total organic chlorine content was determined as the sum of semi-volatile and volatile organic compounds containing chlorine.
Continuous Emissions Monitoring Systems (Tedlar bags are not acceptable alternatives to CEMS)	CO, O <sub>2</sub> CO <sub>2</sub> , and NO <sub>x</sub> stack gas emissions	The effluent gas is continuously or intermittently sampled and the samples are conveyed to a CEM for measurement of the concentration of O <sub>2</sub> by paramagnetic analysis (or other principles), CO and CO <sub>2</sub> by nondispersive infrared (NDIR) (or other principles), and NO <sub>x</sub> by chemiluminescence (or other principles). Combustion efficiency should measure to be 99.9%. Method 3A is a procedure for

EPA Methods 3a, 10, and 7.		measuring oxygen (O <sub>2</sub> ) and carbon dioxide (CO <sub>2</sub> ) and Method 10 for measuring carbon monoxide (CO) in stationary source emissions using a continuous instrumental analyzer. Method 7 is the procedure for measuring Nitrogen oxide (NO <sub>x</sub> )
EPA Method 26a	HCl	This method is applicable for determining emissions of hydrogen halides and halogens. This is included in the modified method 5 sampling train.
EPA Method 5	Particulates	This method is applicable for the determination of PM emissions from stationary sources. This is included in the modified method 5 sampling train.

#### C.4.1.1 Feed Material Samples

As long as the feed material contains PCBs that qualitatively resemble one of the commercial mixtures, such as Aroclors, the traditional analytical methods that use Aroclor mixtures for GC calibration should be acceptable. These methods are discussed below.

##### *C.4.1.1.1 Oils*

The EPA procedure for analysis of PCBs in transformer oils and waste oils (U.S. EPA, 1982b) provides a generalized approach with respect to sample preparation and instrument analysis. Several sample cleanup techniques are provided as optional approaches in this procedure. For the instrument analysis, gas chromatography with halogen-specific, electron capture, or mass spectrometry detectors are all allowed, provided appropriate limits of detection can be achieved. A strong quality control program including control samples, daily quality control check samples, blanks, standard additions, accuracy and precision records, and instrument and chromatographic performance criteria should be in place to support all data generated by the method.

The American Society for Testing and Materials (ASTM, 2000) procedure for electrical insulating mineral oils and silicones employs solvent dilution and a Florisil slurry cleanup prior to GC/ECD determination. The procedure may be applied to the determination of PCB concentrations in insulating liquids contaminated by either individual Aroclors or mixtures of Aroclors. The ASTM procedure notes that the sensitivity of the ECD is reduced by mineral oil and instructs the analyst that the same amount of oil must pass through the detector in both calibration and analysis to ensure a meaningful comparison for quantification.

EPA Method 8082 also provides sample preparation and analysis standards, which may be applied to PCB-contaminated oil. If it is suspected that sulfur is present in the oil sample, it may be appropriate to conduct sulfur removal per EPA Method 8082. Sulfur can be removed using Method 3660.

##### *C.4.1.1.2 Soils, Sludges, and Solid Wastes*

A variety of standard methods are available for soils, sludges, and solid wastes. Several EPA methods utilize dichloromethane extraction, followed by cleanup and gas chromatography determination with different detectors. Soil and other solid wastes may be analyzed by appropriate SW-846 methods (U.S. EPA, 2012), most commonly Method 8082 and 8082A. Method 8082 employs open-tubular, capillary columns with ECD to determine the concentrations of PCBs. When compared to packed columns, the fused-silica, open-tubular columns offer improved resolution, better selectivity, increased sensitivity,



and faster analysis. The target compounds may be determined by either a single- or dual-column analysis system. Compound identification based on single-column analysis should be confirmed on a second column or should be supported by at least one other qualitative technique. In most cases, Method 8270 is not appropriate for the quantitation of multicomponent analytes (i.e., Aroclors) because of limited sensitivity for those analytes. When these analytes have been identified by another technique, such as Method 8082, Method 8270 is appropriate for confirmation of the presence of these analytes, provided the concentration in the extract is above the detection limit.

ASTM Method D6160-98 (ASTM, 2003) is a two-tiered analytical approach to PCB screening and quantitation of oils, sludges, solid wastes, and other matrices. Tier I is designed to screen samples rapidly for the presence of PCBs. Tier II is used to determine the concentrations of PCBs, typically in the range of 2 to 50 mg/kg (ppm). PCB concentrations greater than 50 mg/kg are determined through analysis of sample dilutions. ASTM Method D6160-98 provides sample cleanup and instrument conditions necessary for the determination of Aroclors by GC/ECD. This is a pattern-recognition approach that does not take into account individual congeners that might occur, such as in reaction by-products.

For sludge, EPA Method 624-S (U.S. EPA, 1984b) provides optional Florisil, silica gel, and gel permeation chromatography (GPC) cleanups and stipulates electron impact mass spectrometry (EIMS) as the GC detector. Quantitation is by total areas compared to total areas of Aroclor standards.

#### *C.4.1.1.3 Capacitors and Other Solids*

No standard methods exist specifically for these matrices. The sample should be physically prepared by shredding or grinding and then extracted with an appropriate solvent (e.g., hexane), preferably with a Soxhlet apparatus over multiple cycles. Cleanup and analysis can then follow one of the methods given above.

#### *C.4.1.2 Stack Gas Samples*

As previously indicated in Section C.3.5, it is possible to make all semi-volatile determinations (PCBs, PCDDs, PCDFs, and SVOCs) from a single modified EPA Method 5 (SW-846 Method 0010) sampling train that has been spiked with the SW-846 Method 0023A standards (U.S. EPA, 2001). However, toluene train rinses from the PCDDs and PCDFs recovery must be stored separately from other train rinses, the condensate and impinger contents and rinses must be retained and analyzed, and two separate Soxhlet extractions using different solvents are necessary.

A general combined process is described below:

- Perform a first Soxhlet extraction of Method 0010 train components with methylene chloride.
- Remove the methylene chloride from the extraction flask. Split the methylene chloride extract in half, one half for the PCDD/PCDF analysis and the other half for everything else.
- Add the toluene rinse to the remaining contents of the Soxhlet extractor, and perform a second extraction with toluene.
- Remove the toluene extract from the extraction flask. Combine half of the toluene extract with half of the methylene chloride extract and subject the combined extract to PCDD/PCDF cleanup and analysis; archive the other half of the toluene extract.
- Divide the remaining methylene chloride extract into three portions; perform PAH cleanup and analysis on one portion, PCB cleanup and analysis on a second portion, and analyze the third

portion directly for SVOCs and/or chlorobenzenes/chlorophenols.

Analytical methods available for PCB analysis include EPA Method 1668A (U.S. EPA, 1999). EPA Method 1668A is for determination of chlorinated biphenyl congeners by high resolution gas chromatography/high resolution mass spectrometry (HRGC/HRMS).

EPA occasionally publishes Federal Register Notices that identify broadly applicable alternative test methods for air sampling. A list of the alternative methods can be found at <https://www.epa.gov/emc/broadly-applicable-approved-alternative-test-methods>. Applicants may propose to use these broadly applicable alternative test methods in lieu of otherwise specified reference test methods. For example, ALT 052 is a modified EPA Method 23 that allows the use of only acetone and toluene as recovery solvents instead of using acetone, methylene chloride, and toluene as specified by the method. Also, this modified method allows acetone and toluene rinses to be combined into one sample prior to extraction and analysis instead of analyzing the toluene rinse separately as required by the method.

#### C.4.1.3 Ash Samples

Ash samples collected from thermal processes typically will contain significantly altered Aroclor patterns. If the applicant can demonstrate that the Aroclor patterns were not altered during the disposal process, methods previously presented in Section C.4.1.1.2 can be employed for the determination of Aroclors. The methods presented in the following paragraphs can be employed to determine PCB content of the ash samples based on determination of homologs or congeners.

If the applicant chooses to use GC/ECD as the instrumental method, a mixture of 10 PCB congeners (one each for the various levels of chlorination) may be used for the calibration. Individual peaks are quantified versus the appropriate homolog standard based on the homolog window in which it elutes. Homolog totals are obtained by summing the individual PCB peak amounts for each homolog window. The total PCB concentration is then calculated from the sum of the individual homolog totals. Sample preparation (extraction, cleanup, etc.) can be done according to SW-846 (U.S. EPA, 2012). Instrument analysis can be done according to SW-846 Method 8082 or EPA Method 608 (U.S. EPA, 1984b). To quantitate the samples, the following protocol (Midwest Research Institute, 1985) may be used:

- a. Determine the retention windows. Note: This is an arbitrary demarcation and results in misidentification of some congeners as either a higher or lower homolog. However, because the ECD cannot discriminate by homologs, this is the best approach to partitioning the peaks.
  - (1) Record the retention time for each congener in the standard on a data sheet.
  - (2) For the mono-, the window extends from the retention time of the standard, which is the first eluting PCB, to the midpoint between the mono- and di- standards. Start the window sufficiently ahead of the standard elution time (e.g., 0.1 min) to allow for retention time drift.
  - (3) The windows for di- through nona- are the midpoints between the retention times of the standards.
  - (4) For the deca-, which has only one isomer, the window is the retention time of the standard, allowing appropriate time (e.g.,  $\pm 0.1$  min) for retention time drift.
- b. Calculate a linear regression curve for each homolog. The minimum correlation coefficient (e.g., 0.99) should be specified in the QAPP. If this correlation is not obtained, either rerun the

standard curve or perform corrective action as given in the QAPP.

c. Quantitate the samples. Obtain the concentration in  $\mu\text{g/ml}$  of each peak in the sample (as injected on the gas chromatograph) from the regression equations calculated above.

d. Multiply the concentration obtained by the dilution factor, and divide by the original sample weight (or volume) to obtain the concentration in  $\mu\text{g/g}$  (or  $\mu\text{g/ml}$ ) of the original sample. Record this value on the data sheet.

e. Automated quantitation routines incorporating the above principles may be substituted.

For determination of PCB homologs by GC/MS, EPA Method 680 (U.S. EPA, 1985) can be employed. EPA Method 680 utilizes GC/MS operated in the Selected Ion Monitoring (SIM) mode to identify and quantify the various PCB homologs. A summation of the individual PCB homologs may then be used to reliably determine total PCBs.

EPA Method 1668A also allows estimation of homolog totals by level of chlorination (LOC) and estimation of total PCBs in a sample. An isomer from each of the 10 LOCs is used in quantifying each PCB isomer group; total PCB concentration in each sample extract is obtained by summing isomer group concentrations. EPA Method 1668A also is used for congener-specific determination of the 209 chlorinated biphenyls. The determination of total PCBs in a sample is calculated by the summation of the concentrations of each chlorinated biphenyl congener.

#### C.4.1.4 Aqueous Samples

Scrubber water and other aqueous samples can be analyzed by EPA Method 608 (U.S. EPA, 1984c), EPA Method 625 (U.S. EPA, 1984d), EPA Method 8082 (U.S. EPA, 2007), or ASTM Method D5175-91 (ASTM, 1991) only if the Aroclor pattern has not been altered.

If the Aroclor patterns are significantly altered by the destruction/removal process, or if other PCBs (e.g., partially dechlorinated homologs) are observed in the samples, then the methods described in Section C.4.1.3 can be used to determine the total PCB content of the aqueous samples by summation of individual homologs or congeners.

#### C.4.1.5 Final Product or Effluent Samples

For processes that do not alter the PCB composition, such as solvent cleaning processes, the methods previously identified in Section C.4.1.1 for the various feed samples can be adapted to the final product or effluent samples. With the lower detection limits, additional blanks and other QC measures may be appropriate.

If the Aroclor pattern is significantly altered by the destruction/removal process, or if other PCBs are observed in the samples, then the GC/ECD, HRGC/LRMS, or HRGC/HRMS methods described in Section C.4.1.3 for determination of individual PCB homologs or congeners should be employed to identify and quantitate all of the PCBs present in the samples.

#### *C.4.1.5.1 Oils and Other Nonvolatile Organic Liquids*

The sample preparation procedures may follow those listed for the feed samples. Samples then may be analyzed by an appropriate instrumental technique as described above.

#### *C.4.1.5.2 Volatile Organic Liquids*

No specific standard procedures are recommended for these matrices. If the matrix is compatible with the analytical method (e.g., a hydrocarbon and GC/ECD), direct injection or evaporative concentration may be sufficient. If the matrix is not compatible with the analytical method (e.g., a chlorofluorocarbon and GC/ECD), then a solvent-exchange should be conducted. A higher boiling hydrocarbon “keeper” should be added so that the sample is not evaporated to dryness. The samples then may be analyzed by an appropriate instrument technique.

#### *C.4.1.5.3 Dissolvable Solids (Process Waste, Sludge, etc.)*

For samples that readily dissolve in organic solvents such as hexane or methanol/hexane, a weighed aliquot can be dissolved to a known concentration, mixed thoroughly, and then either analyzed directly, or cleaned up as oil.

#### *C.4.1.5.4 Insoluble Granular Solids (Soils, Ash, Non-Bulk Solid Wastes, etc.)*

The sample preparation for soils, sludges, and solid wastes can follow the same procedures outlined for the feed samples in Section C.4.1.1.2. If the Aroclor patterns have not been altered by the PCB destruction/removal process, the analytical methods identified for soils, sludges, and solid wastes in Section C.4.1.1.2 can be employed. Otherwise the GC/ECD, HRGC/LRMS, or HRGC/HRMS methods described in Section C.4.1.3 should be used for determination of the total PCB concentration of the sample.

#### *C.4.1.5.5 Insoluble Bulk Solids*

No standard methods exist specifically for filter media and other bulk solids. The entire sample should be extracted with an appropriate solvent, preferably with a Soxhlet apparatus over multiple cycles. It is important that the entire sample be extracted because the PCB content is most likely not homogeneous and, thus, a subsample probably would not be representative. The choice of extraction solvent depends on the nature of the sample. If the sample is heavily water-laden or hydrophilic, the solvent should wet the surface (e.g., mixed hexane/acetone or hexane/water/acetonitrile). If the sample is hydrophobic, then extraction with a nonpolar solvent such as hexane may be appropriate. The sample analysis by GC/ECD or GC/MS can follow that given in Section C.4.1.3.

### ***C.4.2 Methods for PCDDs and PCDFs***

Because of their extreme toxicity, PCDDs and PCDFs are of environmental concern even at low levels. Therefore, analytical methods should not only be extremely sensitive, but also generate highly reliable results.

The standard reference method for the isokinetic collection of the various PCDD and PCDF congeners is SW-846 Method 0023A that utilizes an XAD-2<sup>®</sup> sorbent trap. Recovery of the sampling train involves the use of an acetone/methylene chloride rinse followed by a toluene rinse. Analysis is by HRGC/HRMS as detailed in SW-846 Method 8290. This method provides procedures for the detection and quantitative measurement of PCDDs and PCDFs in a variety of environmental matrices at parts per trillion (ppt) to parts per quadrillion (ppq) concentrations. This procedure uses matrix specific extraction, analyte specific cleanup, and provides selected cleanup procedures to aid the analyst in elimination of interferences that may be encountered. The method is capable of quantitating total PCDDs, total PCDFs, total TCDD congeners, and total TCDF congeners, in addition to 2,3,7,8-TCDD and 2,3,7,8-TCDF.

**DIOXINS MAY BE FORMED AT TEMPERATURES GREATER THAN 450 °F DUE TO INCOMPLETE COMBUSTION OF PCBs. DRY AIR POLLUTIONS SYSTEMS THAT ARE OPERATED WITHIN THIS RANGE HAVE THE POTENTIAL TO GENERATE AND EMIT SIGNIFICANT LEVELS OF DIOXIN.**

Other methods available for analysis of PCDDs and PCDFs include EPA Method 23 (Appendix A of 40 CFR 60), SW-846 Method 8280, and CARB Method 428.

### ***C.4.3 Total Organic Chlorine (RCI)***

#### ***C.4.3.1 Volatile RCI***

Volatile total organic chlorine is collected on a VOST as described in Section C.3.8 above. The sorbent tubes from the VOST are thermally desorbed by heating and purging with organic-free helium (SW-846 Method 5041A). The gaseous effluent from the tubes is bubbled through pre-purged, organic-free reagent water and trapped on an analytical sorbent trap in a purge-and-trap unit. After desorption, the analytical sorbent trap is heated rapidly and the gas flow from the analytical trap is directed to the head of a wide-bore column under subambient conditions. The volatile total organic chlorine compounds desorbed from the analytical trap are determined by GC/MS using SW-846 Method 8260.

#### ***C.4.3.2 Semi-volatile RCI***

As previously described in Section C.3.5, semi-volatile RCI is collected in an SW-846 Method 0010 sampling train. Sample extraction for semi-volatile RCI is conducted via SW-846 Method 3542. Sample analysis is conducted by SW-846 Method 8270C using GC/MS. The semi-volatile compounds are introduced into the GC/MS by injecting the sample extract into a GC with a narrow-bore, fused-silica capillary column. The GC column is temperature-programmed to separate the analytes, which are then detected with an MS connected to the GC. Analytes eluted from the capillary column are introduced into the MS via a jet separator or a direct connection. Identification of target analytes is accomplished by comparing their mass spectra with the electron impact (or electron impact-like) spectra of authentic standards. Quantitation is accomplished by comparing the response of a major (quantitation) ion relative to an internal standard using a five-point calibration curve. Additional information regarding SVOC sample collection and analysis using the Method 0010 sampling train can be found in Appendix B of U.S. EPA's guidance document entitled Risk Burn Guidance for Hazardous Waste Combustion Facilities (U.S. EPA, 2001).

## C.5 REFERENCES

ASTM, 2003. "Standard Test Method for Organohalide Pesticides and Polychlorinated Biphenyls in Water by Microextraction and Gas Chromatography." West Conshohocken, Pennsylvania: American Society for Testing and Materials, ASTM D 5175-91, January 2003. **Digital Object Identifier (DOI):** 10.1520/D5175-91R03

ASTM, 2008. "Standard Test Method for Determination of Polychlorinated Biphenyls (PCBs) in Waste Materials by Gas Chromatography." West Conshohocken, Pennsylvania: American Society for Testing and Materials, ASTM D 6160-98, August 2008. **DOI:** 10.1520/D6160-98R08

ASTM, 2010. "Standard Test Method for Analysis of Polychlorinated Biphenyls in Insulating Liquids by Gas Chromatography." West Conshohocken, Pennsylvania: American Society for Testing and Materials, ASTM D 4059-00, December 2000. **DOI:** 10.1520/D4059-00R10

California Air Resources Board (CARB), 1990. "[Method 428 - Determination of Polychlorinated Dibenzio-p-dioxin \(PCDD\), Polychlorinated Dibenzofuran \(PCDF\), and Polychlorinated Biphenyl Emissions from Stationary Sources.](#)" Sacramento, California: California Environmental Protection Agency, Engineering and Laboratory Branch, Monitoring and Laboratory Division, September 12, 1990.

Dry Color Manufacturers Association, 1982. "An Analytical Procedure for the Determination of Polychlorinated Biphenyls in Dry Phthalocyanine Blue, Phthalocyanine Green, and Diarylide Yellow Pigments." Arlington, Virginia, 1982.

Erickson, M. D., 1997. "Analytical Chemistry of PCBs, 2<sup>nd</sup> Edition." Boca Raton, Florida: CRC/Lewis Publishers, 1997.

Midwest Research Institute, 1985. "Operating Procedure - Analysis of Samples for PCBs by GC/ECD," EPA Contract No. 68-02-3938, MRI Project No. 8501-A6, December 1985.

U.S. Environmental Protection Agency, 1979. "Continuous Air Pollution Source Monitoring Systems." Washington, D.C.: Office of Research and Development, [EPA-625/6-79-005](#), June 1979.

U.S. Environmental Protection Agency, 1980. "Samplers and Sampling Procedures for Hazardous Waste Streams." Cincinnati, Ohio: Office of Research and Development, Municipal Environmental Research Laboratory, [EPA-600/2-80-018](#), January 1980.

U.S. Environmental Protection Agency, 1982a. "Handbook for Sampling and Sample Preservation of Water and Wastewater." Cincinnati, Ohio: Environmental Monitoring and Support Laboratory, [EPA-600/4-82-029](#), September 1982.

U.S. Environmental Protection Agency, 1982b. "Test Method: The Determination of Polychlorinated Biphenyls in Transformer Fluid and Waste Oils." Cincinnati, Ohio: Office of Research and Development, Environmental Monitoring and Support Laboratory, [EPA/600/4-81-045](#), February 1982.

U.S. Environmental Protection Agency, 1984a. "Sampling and Analysis Methods for Hazardous Waste Combustion." [EPA-600/8-84-002](#), February 1984

U.S. Environmental Protection Agency, 1984b. "Development of Analytical Test Procedures for the Measurement of Organic Priority Pollutants in Sludge." Cincinnati, OH: Environmental Monitoring and Support Lab, EPA 600/4-84-001, January 1984.

U.S. Environmental Protection Agency, 1984c. "[Method 608 - Organochlorine Pesticides and PCBs.](#)" Federal Register, 49, 89-104, October 26, 1984.

U.S. Environmental Protection Agency, 1984d. "[Method 625 - Base/Neutrals, Acids, and Pesticides.](#)" Federal Register, 49, 153-174, October 26, 1984.

U.S. Environmental Protection Agency, 1985. "Test Methods for Determination of Pesticides and PCBs in Water and Soil/Sediment by Gas Chromatography/Mass Spectroscopy, Method 680." Cincinnati, Ohio: Office of Research and Development, Environmental and Support Laboratory, Physical and Chemical Methods Branch, November 1985

U.S. Environmental Protection Agency, 2003. "[Method 1668, Revision C: Chlorinated Biphenyl Congeners in Water, Soil, Sediment, and Tissue by HRGC/HRMS.](#)" Washington, D.C.: Office of Water, EPA-820-R-10-005, April 2010.

U.S. Environmental Protection Agency, 2001. "[Risk Burn Guidance for Hazardous Waste Combustion Facilities.](#)" Washington, D.C.: Office of Land and Emergency Management, EPA530-R-01-001, July 2001.

U.S. Environmental Protection Agency, 2013, Code of Federal Regulations, Title 40, Part 60 (40 CFR 60), "[Standards of Performance for New Stationary Sources, Appendix A - Test Methods.](#)" July 1, 2013.

U.S. Environmental Protection Agency, 2014. "[Test Methods for Evaluating Solid Waste, Physical/Chemical Methods, SW-846.](#)" Washington, D.C.: Office of Land and Emergency Management.

**APPENDIX D**  
**QUALITY ASSURANCE PROJECT PLAN TEMPLATE**



**DISCLAIMER:** THIS TEMPLATE IS ONLY AN EXAMPLE AND IT IS NOT REQUIRED TO BE USED OR SUBMITTED TO EPA

**QUALITY ASSURANCE PROJECT PLAN (QAPP) TEMPLATE**

See [Section 4.2.20](#) for Guidance relating to the QAPP

Approved OMB No. 2070-0211

*[A1: Title and Approval Sheet]*

**QUALITY ASSURANCE PROJECT PLAN FOR  
APPROVAL OF PCB DISPOSAL METHODS**

Submitted to the U.S. Environmental Protection Agency for Approval by:

_____	_____	_____
Name	Signature	Date

_____	_____	_____
Name	Signature	Date

_____	_____	_____
Name	Signature	Date

_____	_____	_____
Name	Signature	Date

**DISCLAIMER: THIS TEMPLATE IS ONLY AN EXAMPLE AND IT IS NOT REQUIRED TO BE USED OR SUBMITTED TO EPA**

*Table of Contents*

A PROJECT MANAGEMENT .....

- A1 Distribution List .....
- A2 Problem Definition/Background .....
- A3 Quality Objectives and Criteria for Measurement Data .....

  - A3.1 Data Quality Objectives .....
  - A3.2 Measurement Performance Criteria.....
  - A3.3 Analytical Data Criteria .....

- A4 Special Training/Certification .....
- A5 Documentation and Records .....

  - A5.1 Data Recording .....
  - A5.2 Field Operation Records .....
  - A5.3 Laboratory Records .....
  - A5.5 Records Management and Document Control.....

B DATA GENERATION AND ACQUISITION.....

- B1 Sampling Process Design .....
- B2 Sample Methods .....
- B3 Sample Handling and Custody .....

  - B3.1 Sample Numbering .....
  - B3.2 Sample Labels.....
  - B3.3 Sample Packaging.....
  - B3.4 Field Chain-of-Custody Record.....
  - B3.5 Sample Transfer and Shipment.....
  - B3.6 Laboratory Sample Custody.....
  - B3.7 Sample Containers, Preservation, and Holding Times.....

- B4 Quality Control.....

  - B4.1 Field QC procedures.....
  - B4.2 Laboratory QA/QC procedures.....
  - B4.3 Data quality indicators.....

- B5 Instrumentation/Equipment Testing, Inspection, and Maintenance.....

  - B5.1 Field Equipment.....
  - B5.2 Laboratory Equipment.....

- B6 Instrument/Equipment Calibration and Frequency .....

  - B6.1 Calibration of Field Instrumentation .....
  - B6.2 Calibration of Laboratory Instrumentation .....

- B7 Inspection/Acceptance of Supplies and Consumables.....
- B8 Non-Direct Measurements.....
- B9 Data Management.....

  - B9.1 Data Recording .....
  - B9.2 Electronic Data Deliverable .....
  - B9.3 Data Validation .....
  - B9.4 Data Transmittal .....
  - B9.5 Data Reduction.....
  - B9.6 Data Analysis .....

**DISCLAIMER: THIS TEMPLATE IS ONLY AN EXAMPLE AND IT IS NOT REQUIRED TO BE USED OR SUBMITTED TO EPA**

- B9.7 Data Tracking and Reporting.....
- B9.8 Data Storage and Retrieval.....
- C ASSESSMENTS/OVERSIGHT .....
- C1 Assessment and Response Actions .....
- C1.1 Field Audits.....
- C1.2 Laboratory Audits.....
- C1.3 System Audits.....
- C1.4 Data Quality Assessments.....
- C1.5 Response Actions.....
- C2 Reports to Management .....
- C2.1 Frequency, Content and Distribution of Reports.....
- C2.2 Personnel Responsible for Report Preparation .....

**DISCLAIMER: THIS TEMPLATE IS ONLY AN EXAMPLE AND IT IS NOT REQUIRED TO BE USED OR SUBMITTED TO EPA**

**A: PROJECT MANAGEMENT**

*A1: Distribution List:*

The following individuals and organizations will receive a copy of the approved QAPP. [Exclude those that do not apply.]

- [Name], Senior Manager
- [Name], Quality Assurance Officer
- [Name], Senior Laboratory Personnel
- [Name], Project Manager/Demonstration Lead
- [Name], Quality Assurance Officer
- [Name], Health and Safety Officer
- [Name], Field Team Leader
- [Name], Field Team Member
- [Name], Laboratory Coordinator
- [Name], Technical Staff
- [Name], Analytical Laboratory

*A2: Problem Definition/Background:*

[Describe the project or refer to other submitted documents with a project description.]

The purpose of this project is [insert purpose of the project, e.g., to properly dispose of PCBs through incineration].

The data generated will be used to ensure that [insert explanation here, e.g., the wastes that will be managed by the facility are within the scope of the approval].

The data quality needs to meet [insert data quality standards here] to accomplish the goals of the project.

*A3: Quality Objectives and Criteria:*

The outputs from the systematic planning process which are used to design the study and measurement performance or acceptance criteria established (e.g., precision, bias, accuracy, representativeness, comparability, completeness, sensitivity) as part of the study design are described below. For example:

*A3.1 Data Quality Objectives*

[For help with the DQOs, EPA provides guidance on the DQO process to help in the development of an appropriate study design (EPA, 2000 and 2006a)].

*A3.2 Measurement Performance Criteria*

**DISCLAIMER: THIS TEMPLATE IS ONLY AN EXAMPLE AND IT IS NOT REQUIRED TO BE USED OR SUBMITTED TO EPA**

The measurement performance criteria (MPCs) are [insert description of measurement performance criteria, e.g., combustion efficiency and/or destruction removal efficiency].

*A3.3 Analytical Data Criteria*

[Insert description of analytical data criteria, e.g., use of split samples and/or performance evaluation samples.]

*A4: Special Training/Certification:*

[Insert description of certifications held or that will be obtained by personnel and methods of tracking these certifications.]

*A5: Documentation and Records:*

[Insert description of documentation and recordkeeping, such as records and documents to be included in final report, where the records will be kept, etc.]

*A5.1 Data Recording*

[Insert description of how data will be recorded, e.g., use of data logging software.]

*A5.2 Field Operation Records*

[Insert description of field operation record-keeping methods, e.g., use of field logbooks.]

*A5.3 Laboratory Records*

[Insert description of laboratory activity documentation methods, e.g., use of sample custody records.].

*A5.4 Records Management and Document Control*

[Insert description of records management plan and document distribution methods, e.g., records retention schedules.]

**B: DATA GENERATION AND ACQUISITION**

*B1: Sampling Process Design (Experimental Design):*

[Insert a description of the project's experimental design, including, as applicable, a table that summarizes the components of the monitoring and sampling plan.]

**DISCLAIMER: THIS TEMPLATE IS ONLY AN EXAMPLE AND IT IS NOT REQUIRED TO BE USED OR SUBMITTED TO EPA**

*B2: Sampling Methods:*

[Insert a description of sample/data collection procedures; list of equipment needed; identification of performance requirements; description of corrective actions to be taken if problems arise.]

*B3: Sample Handling and Custody:*

[Insert description of how samples will be handled and transferred for ultimate disposal.]

*B3.1 Sample Numbering*

[Describe how samples will be numbered for unique identification.]

*B3.2 Sample Labels*

[Describe sample labeling procedures and methods.]

*B3.3 Sample Packaging*

[Insert description of sample packaging methods. Include details surrounding shipping.]

*B3.4 Field Chain-of-Custody Record*

[Insert description of sample custody records.]

*B3.5 Sample Transfer and Shipment*

[Insert description of sample transfer and shipment procedures, e.g., use of tracking numbers.]

*B3.6 Laboratory Sample Custody*

[Insert description of laboratory sample custody procedures, e.g., sample condition checklist for use by sample custodian receiving samples.]

*B4: Quality Control:* [Insert list of QC activities for samples, such as sampling techniques and frequency, control limits, corrective actions and statistics]

*B4.1 Field QC procedures*

[Insert field sampling QC procedures.]

Table 1. Definitions, Requirements, and Frequency for Typical Field QC Samples

QC Sample	Description	Typical Frequency <sup>1</sup>
Equipment Blank	[Insert description of criteria for equipment blanks.]	[Insert frequency].
Field Duplicate	[Insert description of criteria for field duplicates.]	[Insert frequency].

**DISCLAIMER: THIS TEMPLATE IS ONLY AN EXAMPLE AND IT IS NOT REQUIRED TO BE USED OR SUBMITTED TO EPA**

<b>QC Sample</b>	<b>Description</b>	<b>Typical Frequency<sup>1</sup></b>
Field Blank	[Insert description of criteria for field blanks.]	[Insert frequency].
Trip Blank	[Insert description of criteria for trip blanks.]	[Insert frequency].

*B4.2 Laboratory QA/QC procedures*

[Insert description of laboratory QA/QC procedures.]

Table 2. Definitions, Requirements, and Frequency for Typical Laboratory QC Samples

<b>QC Sample</b>	<b>Description</b>	<b>Typical Frequency</b>
Matrix Spike	[Insert matrix spike description.]	[Insert frequency].
Calibration Blank (CB)	[Insert CB description.]	[Insert frequency].
Method Blank (MB)	[Insert MB description.]	[Insert frequency].
Surrogate Internal Standards (SIS)	[Insert SIS description.]	[Insert frequency].
Calibration Check Standards (CCS)	[Insert CCS description.]	[Insert frequency].
Recovery Internal Standards (RIS)	[Insert RIS description.]	[Insert frequency].
Laboratory Control Sample (LCS)	[Insert LCS description.]	[Insert frequency].
Reagent or Solvent Purity Checks	[Insert reagent or solvent purity checks description.]	[Insert frequency].

*B4.3 Data quality indicators*

[Insert description of quantitative and qualitative data quality indicators (DQIs), such as accuracy, precision, etc. See the glossary for quality control statistics, e.g., percent recovery.]

**DISCLAIMER: THIS TEMPLATE IS ONLY AN EXAMPLE AND IT IS NOT REQUIRED TO BE USED OR SUBMITTED TO EPA**

Table 3. QC Sample Acceptance Criteria and Corrective Actions

<b>QC Sample</b>	<b>Acceptance Criteria</b>	<b>Corrective Action</b>
<i>Equipment Blank</i>	[Insert acceptance criteria for this sample].	[Insert description of corrective action that will be taken.]
<i>Instrument Solvent Blank</i>	[Insert acceptance criteria for this sample].	[Insert description of corrective action that will be taken.]
<i>Method Blank</i>	[Insert acceptance criteria for this sample].	[Insert description of corrective action that will be taken.]
<i>Matrix Spike</i>	[Insert acceptance criteria for this sample.]	[Insert description of corrective action that will be taken.]
<i>Surrogate Spike</i>	[Insert acceptance criteria for this sample.]	[Insert description of corrective action that will be taken.]
<i>Laboratory Control Sample</i>	[Insert acceptance criteria for this sample.]	[Insert description of corrective action that will be taken.]
<i>Instrument Check</i>	[Insert acceptance criteria for this sample.]	[Insert description of corrective action that will be taken.]
<i>Duplicate Sample</i>	[Insert acceptance criteria for this sample.]	[Insert description of corrective action that will be taken.]

*B5: Instrument/Equipment Testing, Inspection, and Maintenance:* [Insert description of equipment testing, inspection, and maintenance methods and schedule.]

*B5.1 Field Equipment*

[Insert summary table of maintenance procedures for field testing equipment below.]

Table 4. Examples of Maintenance Activities for Field Testing Equipment

<b>Equipment</b>	<b>Maintenance Activity</b>	<b>Frequency</b>	<b>Corrective Action</b>
CEMs	[Insert description of maintenance activity].	[Insert frequency].	[Insert corrective action].
Sampling trains	[Insert description of maintenance activity].	[Insert frequency].	[Insert corrective action].



**DISCLAIMER: THIS TEMPLATE IS ONLY AN EXAMPLE AND IT IS NOT REQUIRED TO BE USED OR SUBMITTED TO EPA**

Rotameter	[Insert description of maintenance activity].	[Insert frequency].	[Insert corrective action].
Pressure transducer	[Insert description of maintenance activity].	[Insert frequency].	[Insert corrective action].
Thermocouple	[Insert description of maintenance activity].	[Insert frequency].	[Insert corrective action].
Volumetric flow meter	[Insert description of maintenance activity].	[Insert frequency].	[Insert corrective action].

*B5.2 Laboratory Equipment*

[Insert description of routine testing and maintenance of laboratory equipment, including a table similar to Table 4, if applicable.]

*B6: Instrument/Equipment Calibration and Frequency:* [Insert list of all project equipment which should be calibrated, method and frequency of calibration, etc.]

*B6.1 Calibration of Field Instrumentation*

[Insert table with description of calibration of field instrumentation below.]

Table 5. Examples of Calibration Procedures for Stack Sampling Equipment

<b>Equipment</b>	<b>Calibration Procedure</b>	<b>Frequency</b>	<b>Acceptance Criteria</b>
CEMs	[Insert calibration procedure]	[Insert frequency]	[Insert acceptance criteria]
Sampling trains	[Insert calibration procedure]	[Insert frequency]	[Insert acceptance criteria]
Rotameter	[Insert calibration procedure]	[Insert frequency]	[Insert acceptance criteria]
Pressure transducer	[Insert calibration procedure]	[Insert frequency]	[Insert acceptance criteria]
Thermocouple	[Insert calibration procedure]	[Insert frequency]	[Insert acceptance criteria]

**DISCLAIMER: THIS TEMPLATE IS ONLY AN EXAMPLE AND IT IS NOT REQUIRED TO BE USED OR SUBMITTED TO EPA**

Volumetric flow meter	[Insert calibration procedure]	[Insert frequency]	[Insert acceptance criteria]
-----------------------	--------------------------------	--------------------	------------------------------

*B6.2 Calibration of Laboratory Instrumentation*

[Insert laboratory instrumentation calibration procedures in table below].

Table 6. Examples of Calibration Procedures for Laboratory Equipment

<b>Equipment</b>	<b>Calibration Procedure</b>	<b>Frequency</b>	<b>Acceptance Criteria</b>
Analytical balance	[Insert calibration procedure.]	[Insert frequency.]	[Insert acceptance criteria.]
GC	[Insert calibration procedure.]	[Insert frequency.]	[Insert acceptance criteria.]
Pipettes	[Insert calibration procedure.]	[Insert frequency.]	[Insert acceptance criteria.]
Thermometers	[Insert calibration procedure.]	[Insert frequency.]	[Insert acceptance criteria.]

*B7: Inspection/Acceptance for Supplies and Consumables:*

[Insert list of project supplies and consumables and their acceptance criteria.]

*B8: Non-direct Measurements:*

[Insert description of any existing data that will be obtained from non-measurement sources, such as literature files, planned use of data, acceptance criteria and limitations.]

*B9: Data Management:* [Insert description of the project data management process, e.g., data storage, software.]

*B9.1 Data Recording*

[Insert description of data recording procedures. For more information, see Section A9, “Documentation and Records.”]

*B9.2 Electronic Data Deliverable*

[Insert description of electronic data format and method of delivery.]

**DISCLAIMER: THIS TEMPLATE IS ONLY AN EXAMPLE AND IT IS NOT REQUIRED TO BE USED OR SUBMITTED TO EPA**

*B9.3 Data Validation*

[Insert description of data validation procedures. For information about specific data validation techniques, see Sections D1 through D3.]

*B9.4 Data Transmittal*

[Insert description of data transmittal methods.]

*B9.5 Data Reduction*

[Insert description of data reduction methods.]

*B9.6 Data Analysis*

[Insert description of data analysis methods.]

*B9.7 Data Tracking and Reporting*

[Insert description of data tracking and reporting methods.]

*B9.8 Data Storage and Retrieval*

[Insert description of data storage and retrieval methods, such as types of data to be collected, storage media, procedures for safeguarding the data, etc.]

**C: ASSESSMENTS/OVERSIGHT**

*C1: Assessments and Response Actions:*

[Insert description of project assessments planned, information expected, schedule, participants, reporting of results, etc.]

*C1.1 Field Audits*

[Insert description of field audit procedures.]

*C1.2 Laboratory Audits*

[Insert description of laboratory audit procedures.]

*C1.3 Data Quality Assessments*

[Insert description of data quality assessment procedures.]

*C1.5 Response Actions*

[Insert description of response action procedures.]

**DISCLAIMER:** THIS TEMPLATE IS ONLY AN EXAMPLE AND IT IS NOT REQUIRED TO BE USED OR SUBMITTED TO EPA

*C2: Reports to Management:*

[Insert description of procedure to report to management about project's status.]

*C2.1 Frequency, Content and Distribution of Reports*

[Insert description of frequency, content and distribution of reports.]

*C2.2 Personnel Responsible for Report Preparation*

[Insert description of personnel responsible for report preparation.]

**APPENDIX E**  
**CLEANUP, EXTRACTION, AND DETERMINATIVE METHODS FOR**  
**PCB AROCLORS, HOMOLOGS, AND CONGENERS**

**Disclaimer:** Methods discussed in this guidance are for informational purposes and do not guarantee the use of any specific method. EPA may require a specific method or not accept the method requested by the applicant to be used on a case-by-case basis. In some instances, EPA may require a comparison study of a proposed method with an EPA method before determining whether or not to allow the proposed method. Additionally, methods may be updated in the future and EPA’s stance on a particular method may change.

**Table E-1. Summary of Extraction Methods for PCB Samples**

<b>Method</b>	<b>Matrix Types</b>	<b>Extraction Technique</b>	<b>Analytes</b>
Method 3510	Aqueous	Separatory Funnel Liquid-Liquid Extraction	Semi-volatile and Nonvolatile Organics
Method 3520	Aqueous	Continuous Liquid-Liquid Extraction	Semi-volatile and Nonvolatile Organics
Method 3535	Aqueous	Solid-phase Extraction	Semi-volatile and Nonvolatile Organics
Method 3540	Solids	Soxhlet Extraction	Semi-volatile and Nonvolatile Organics
Method 3541	Solids	Automated Soxhlet Extraction	Semi-volatile and Nonvolatile Organics
Method 3542	Air Sampling Train	Separatory Funnel & Soxhlet Extraction	Semi-volatile Organics
Method 3545	Solids	Pressurized Fluid Extraction	Semi-volatile and Nonvolatile Organics
Method 3546	Solids	Microwave Extraction	Semi-volatile and Nonvolatile Organics
Method 3550	Solids	Ultrasonic Extraction	Semi-volatile and Nonvolatile Organics
Method 3562	Solids	Supercritical Fluid Extraction	PCBs and Organochlorine Pesticides

**Table E-2. Summary of Cleanup Methods for PCB Samples**

Method No.	Method Name	Cleanup Type
Method 3610	Alumina Cleanup	Adsorption
Method 3611	Alumina Cleanup and Separation of Petroleum Wastes	Adsorption
Method 3620	Florisil Cleanup	Adsorption
Method 3630	Silica Gel Cleanup	Adsorption
Method 3640	Gel-Permeation Cleanup (GPC)	Size-Separation
Method 3650	Acid-Base Partition Cleanup	Acid-Base Partitioning
Method 3660	Sulfur Cleanup	Oxidation/Reduction
Method 3665	Sulfuric Acid/Permanganate	Oxidation/Reduction

**Table E-3. Summary of Analytical Methods for PCB Samples**

Matrix	Method	Description
<i>Feed Material</i>		
Oils	EPA/600/4-81-045	GC with halogen-specific ECD or MS (Aroclor)
	ASTM D 4059-00	
	SW-846 Method 8082A	GC/ECD (Aroclor)
Soils, sludges, solid wastes	SW-846 Method 8082A	GC/ECD(Aroclor)
	ASTM Method D6160-98	GC/ECD (Aroclor)
	EPA Method 624-S	GPC (Aroclor)
Capacitors	No standard method exists  Select from methods given above	
Stack gas samples	EPA Method 1668A  CARB Method 428*	HRGC/HRMS (Congeners)  HRGC with low resolution, electron ionization mass spectrometry (LRMS) (Homolog)

Ash samples	SW-846 Method 8082A EPA Method 680 EPA Method 1668A	GC/ECD (Aroclor) GC/MS in Selected Ion Monitoring (SIM) mode (Homolog) HRGC/HRMS (Congeners)
Aqueous samples	EPA Method 608 EPA Method 680 EPA Method 625.1 ASTM Method D5175-91	GC/ECD (Aroclor) GC/MS in SIM mode (Homolog) GC/MS (Aroclor) GC/MS (Aroclor)
<i>Final Product/Effluent</i>		
Oils/ Organic Liquids	EPA/600/4-81-045 ASTM D 4059-00 SW-846 Method 8082A EPA Method 680 EPA Method 1668A	GC with halogen-specific ECD or MS (Aroclor) GC/ECD (Aroclor) GC/ECD (Aroclor) GC/MS in Selected Ion Monitoring (SIM) mode (Homolog) HRGC/HRMS (Congeners)
Insoluble granular solids (Soils, Ash, Non-Bulk Solid Wastes, etc.) and dissolvable Solids (Process Waste, Sludge, etc.)	SW-846 Method 8082A ASTM Method D6160-98 EPA Method 624 EPA Method 680 EPA Method 1668	GC/ECD (Aroclor) GC/ECD (Aroclor) GC/MS (Aroclor) GC/MS HRGC/HRMS
Insoluble Bulk Solids (filter media, wipe samples, etc.)	SW-846 Method 8082A	GC/ECD (Aroclor)



DISCLAIMER: THESE CHECKLISTS ARE ONLY EXAMPLES AND THEY ARE NOT  
REQUIRED TO BE USED OR SUBMITTED TO EPA

**APPENDIX F**  
**EXAMPLE CHECKLISTS FOR THERMAL AND NON-THERMAL**  
**TECHNOLOGIES FOR USE DURING THE TEST**

DISCLAIMER: THESE CHECKLISTS ARE ONLY EXAMPLES AND THEY ARE NOT  
REQUIRED TO BE USED OR SUBMITTED TO EPA

**Table F-1. Example Checklist for Thermal Alternative Methods (e.g., Thermal Desorber) for Use  
During the Test\***

Parameter	Yes	No
Is O <sub>2</sub> being measured? What is the concentration? _____ % Provide instrument information: Manufacturer: Model:		
Is CO being measured? What is the concentration? _____ ppm Provide instrument information: Manufacturer: Model:		
Is CO <sub>2</sub> being measured? What is the concentration? _____ % Provide instrument information: Manufacturer: Model:		
Is the waste feed rate being monitored? Provide instrument information: Manufacturer: Model:		
Is the residence time being calculated?		
Is the combustion efficiency (if afterburner is present) being calculated? Has the efficiency been demonstrated to 99.9%?		
Is the venturi pressure drop being measured? Provide instrument information: Manufacturer: Model:		
Is the venturi scrubber liquid flow being measured? Provide instrument information: Manufacturer: Model:		
Is the spray tower liquid flow rate monitored? Provide instrument information: Manufacturer: Model:		

DISCLAIMER: THESE CHECKLISTS ARE ONLY EXAMPLES AND THEY ARE NOT REQUIRED TO BE USED OR SUBMITTED TO EPA

**Table F-1 (cont.). Example Checklist for Thermal Alternative Methods (i.e., Thermal Desorber) for Use During the Test\***

Parameter	Yes	No
Is the quench water discharge rate monitored? Provide instrument information: Manufacturer: Model:		
Is the scrubber liquid discharge rate monitored? Provide instrument information: Manufacturer: Model:		
Is the quench water make-up rate monitored? Provide instrument information: Manufacturer: Model:		
Is the scrubber liquid make-up flow rate monitored? Provide instrument information: Manufacturer: Model:		
Are ash/residue samples collected? Sample ID: _____		
Approved OMB No. 2070-0211		

\*Additional monitoring may be needed.

DISCLAIMER: THESE CHECKLISTS ARE ONLY EXAMPLES AND THEY ARE NOT REQUIRED TO BE USED OR SUBMITTED TO EPA

**Table F-2: Example Checklist for Non-Thermal Alternative Methods (i.e., Chemical Dechlorination) for Use During the Test\***

Parameter	Yes	No
Was a waste feed sample collected? Sample ID: _____		
Are process product samples collected from the reaction vessel? Sample ID: _____ Are process product samples collected from the storage tank? Sample ID: _____		
Is the waste feed rate monitored?		
Is the product rate monitored?		
Is the reagent feed rate monitored?		
Is the quench feed rate monitored?		
Is the reaction vessel pressure monitored? Provide instrument information: Manufacturer: Model:		
Is the reaction vessel temperature monitored? Provide instrument information: Manufacturer: Model:		
Are vent emissions to ambient air being monitored? Provide instrument information: Manufacturer: Model:		
Approved OMB No. 2070-0211		

\*Additional monitoring may be needed.

**APPENDIX G**  
**PCB AROCLORS, HOMOLOGS, AND CONGENERS**

As a reminder, the definitions of Aroclor, Congener, and Homolog are provided below

### **Aroclor**

A commercial mixture of PCBs previously manufactured by Monsanto. Aroclor is one of the most commonly known trade names for PCB mixtures. There are many types of Aroclors and each has a distinguishing suffix number that indicates the degree of chlorination. The numbering standard for the different Aroclors is as follows: The first two digits are usually "12," which represents a 1200 series product as designated by Monsanto. A 1200 series PCB product is a refined PCB product usually derived from the 1100 series crude PCBs. The second two numbers indicate the percentage of chlorine by mass in the mixture. For example, the name Aroclor 1254 means that the mixture contains approximately 54% chlorine by weight.

### **Congener**

Any single, unique, well-defined chemical compound in the PCB category. The name of a congener specifies the total number of chlorine substituents, and the position of each chlorine.

For example, 4,4'-Dichlorobiphenyl is a congener comprising the biphenyl structure with two chlorine substituents - one on each of the #4 carbons of the two rings.

Altogether, there are 209 individual PCB congeners having the molecular formula  $C_{12}H_nCl_{10-n}$ , where  $n = 0-9$ . This definition includes monochlorobiphenyls.

### **Homolog**

Subcategories of PCB congeners that have equal numbers of chlorine substituents. For example, the tetrachlorobiphenyls are all PCB congeners with exactly 4 chlorine substituents that can be in any arrangement. Altogether, there are 10 homologs.

**Table G-1. List of PCB Aroclors**

<b>Chemical Abstract Service Registry Number (CASRN)</b>	<b>IUPAC Name Type</b>
12674-11-2	Aroclor 1016
147601-87-4	Aroclor 1210
151820-27-8	Aroclor 1216
11104-28-2	Aroclor 1221
37234-40-5	Aroclor 1231
11141-16-5	Aroclor 1232
71328-89-7	Aroclor 1240
53469-21-9	Aroclor 1242
12672-29-6	Aroclor 1248
165245-51-2	Aroclor 1250
89577-78-6	Aroclor 1252
11097-69-1	Aroclor 1254
11096-82-5	Aroclor 1260
37324-23-5	Aroclor 1262
11100-14-4	Aroclor 1268
12767-79-2	Aroclor (unspecified)

**Table G-2. List of PCB Homologs**

<b>CASRN</b>	<b>IUPAC Name</b>	<b>Number of Isomers</b>
27323-18-8	Monochlorobiphenyl	3
25512-42-9	Dichlorobiphenyl	12
25323-68-6	Trichlorobiphenyl	24
26914-33-0	Tetrachlorobiphenyl	42
25429-29-2	Pentachlorobiphenyl	46
26601-64-9	Hexachlorobiphenyl	42
28655-71-2	Heptachlorobiphenyl	24
55722-26-4	Octachlorobiphenyl	12
53742-07-7	Nonachlorobiphenyl	3
2051-24-3	Decachlorobiphenyl	1



**Table G-3. List of PCB Congeners**

<b>CASRN</b>	<b>Congener Number</b>	<b>IUPAC Name</b>
2051-60-7	1	2-Chlorobiphenyl
2051-61-8	2	3-Chlorobiphenyl
2051-62-9	3	4-Chlorobiphenyl
13029-08-8	4	2,2'-Dichlorobiphenyl
16605-91-7	5	2,3-Dichlorobiphenyl
25569-80-6	6	2,3'-Dichlorobiphenyl
33284-50-3	7	2,4-Dichlorobiphenyl
34883-43-7	8	2,4'-Dichlorobiphenyl
34883-39-1	9	2,5-Dichlorobiphenyl
33146-45-1	10	2,6-Dichlorobiphenyl
2050-67-1	11	3,3'-Dichlorobiphenyl
2974-92-7	12	3,4-Dichlorobiphenyl
2974-90-5	13	3,4'-Dichlorobiphenyl
34883-41-5	14	3,5-Dichlorobiphenyl
2050-68-2	15	4,4'-Dichlorobiphenyl
38444-78-9	16	2,2',3-Trichlorobiphenyl
37680-66-3	17	2,2',4-Trichlorobiphenyl
37680-65-2	18	2,2',5-Trichlorobiphenyl
38444-73-4	19	2,2',6-Trichlorobiphenyl
38444-84-7	20	2,3,3'-Trichlorobiphenyl
55702-46-0	21	2,3,4-Trichlorobiphenyl
38444-85-8	22	2,3,4'-Trichlorobiphenyl
55720-44-0	23	2,3,5-Trichlorobiphenyl
55702-45-9	24	2,3,6-Trichlorobiphenyl
55712-37-3	25	2,3',4-Trichlorobiphenyl
38444-81-4	26	2,3',5-Trichlorobiphenyl
38444-76-7	27	2,3',6-Trichlorobiphenyl
7012-37-5	28	2,4,4'-Trichlorobiphenyl
15862-07-4	29	2,4,5-Trichlorobiphenyl
35693-92-6	30	2,4,6-Trichlorobiphenyl
16606-02-3	31	2,4',5-Trichlorobiphenyl
38444-77-8	32	2,4',6-Trichlorobiphenyl
38444-86-9	33	2,3',4'-Trichlorobiphenyl
37680-68-5	34	2,3',5'-Trichlorobiphenyl
37680-69-6	35	3,3',4-Trichlorobiphenyl
38444-87-0	36	3,3',5-Trichlorobiphenyl
38444-90-5	37	3,4,4'-Trichlorobiphenyl
53555-66-1	38	3,4,5-Trichlorobiphenyl

**Table G-3 (cont.). Summary of PCB Congeners**

<b>CASRN</b>	<b>Congener Number</b>	<b>IUPAC Name</b>
38444-88-1	39	3,4',5-Trichlorobiphenyl
38444-93-8	40	2,2',3,3'-Tetrachlorobiphenyl
52663-59-9	41	2,2',3,4-Tetrachlorobiphenyl
36559-22-5	42	2,2',3,4'-Tetrachlorobiphenyl
70362-46-8	43	2,2',3,5-Tetrachlorobiphenyl
41464-39-5	44	2,2',3,5'-Tetrachlorobiphenyl
70362-45-7	45	2,2',3,6-Tetrachlorobiphenyl
41464-47-5	46	2,2',3,6'-Tetrachlorobiphenyl
2437-79-8	47	2,2',4,4'-Tetrachlorobiphenyl
70362-47-9	48	2,2',4,5-Tetrachlorobiphenyl
41464-40-8	49	2,2',4,5'-Tetrachlorobiphenyl
62796-65-0	50	2,2',4,6-Tetrachlorobiphenyl
68194-04-7	51	2,2',4,6'-Tetrachlorobiphenyl
35693-99-3	52	2,2',5,5'-Tetrachlorobiphenyl
41464-41-9	53	2,2',5,6'-Tetrachlorobiphenyl
15968-05-5	54	2,2',6,6'-Tetrachlorobiphenyl
74338-24-2	55	2,3,3',4-Tetrachlorobiphenyl
41464-43-1	56	2,3,3',4'-Tetrachlorobiphenyl
70424-67-8	57	2,3,3',5-Tetrachlorobiphenyl
41464-49-7	58	2,3,3',5'-Tetrachlorobiphenyl
74472-33-6	59	2,3,3',6-Tetrachlorobiphenyl
33025-41-1	60	2,3,4,4'-Tetrachlorobiphenyl
33284-53-6	61	2,3,4,5-Tetrachlorobiphenyl
54230-22-7	62	2,3,4,6-Tetrachlorobiphenyl
74472-34-7	63	2,3,4',5-Tetrachlorobiphenyl
52663-58-8	64	2,3,4',6-Tetrachlorobiphenyl
33284-54-7	65	2,3,5,6-Tetrachlorobiphenyl
32598-10-0	66	2,3',4,4'-Tetrachlorobiphenyl
73575-53-8	67	2,3',4,5-Tetrachlorobiphenyl
73575-52-7	68	2,3',4,5'-Tetrachlorobiphenyl
60233-24-1	69	2,3',4,6-Tetrachlorobiphenyl
32598-11-1	70	2,3',4',5-Tetrachlorobiphenyl
41464-46-4	71	2,3',4',6-Tetrachlorobiphenyl
41464-42-0	72	2,3',5,5'-Tetrachlorobiphenyl
74338-23-1	73	2,3',5',6-Tetrachlorobiphenyl
32690-93-0	74	2,4,4',5-Tetrachlorobiphenyl
32598-12-2	75	2,4,4',6-Tetrachlorobiphenyl
70362-48-0	76	2,3',4',5'-Tetrachlorobiphenyl
32598-13-3	77	3,3',4,4'-Tetrachlorobiphenyl

**Table G-3 (cont.). Summary of PCB Congeners**

<b>CASRN</b>	<b>Congener Number</b>	<b>IUPAC Name</b>
70362-49-1	78	3,3',4,5-Tetrachlorobiphenyl
41464-48-6	79	3,3',4,5'-Tetrachlorobiphenyl
33284-52-5	80	3,3',5,5'-Tetrachlorobiphenyl
70362-50-4	81	3,4,4',5-Tetrachlorobiphenyl
52663-62-4	82	2,2',3,3',4-Pentachlorobiphenyl
60145-20-2	83	2,2',3,3',5-Pentachlorobiphenyl
52663-60-2	84	2,2',3,3',6-Pentachlorobiphenyl
65510-45-4	85	2,2',3,4,4'-Pentachlorobiphenyl
55312-69-1	86	2,2',3,4,5-Pentachlorobiphenyl
38380-02-8	87	2,2',3,4,5'-Pentachlorobiphenyl
55215-17-3	88	2,2',3,4,6-Pentachlorobiphenyl
73575-57-2	89	2,2',3,4,6'-Pentachlorobiphenyl
68194-07-0	90	2,2',3,4',5-Pentachlorobiphenyl
68194-05-8	91	2,2',3,4',6-Pentachlorobiphenyl
52663-61-3	92	2,2',3,5,5'-Pentachlorobiphenyl
73575-56-1	93	2,2',3,5,6-Pentachlorobiphenyl
73575-55-0	94	2,2',3,5,6'-Pentachlorobiphenyl
38379-99-6	95	2,2',3,5',6-Pentachlorobiphenyl
73575-54-9	96	2,2',3,6,6'-Pentachlorobiphenyl
41464-51-1	97	2,2',3,4',5'-Pentachlorobiphenyl
60233-25-2	98	2,2',3,4',6'-Pentachlorobiphenyl
38380-01-7	99	2,2',4,4',5-Pentachlorobiphenyl
39485-83-1	100	2,2',4,4',6-Pentachlorobiphenyl
37680-73-2	101	2,2',4,5,5'-Pentachlorobiphenyl
68194-06-9	102	2,2',4,5,6'-Pentachlorobiphenyl
60145-21-3	103	2,2',4,5',6-Pentachlorobiphenyl
56558-16-8	104	2,2',4,6,6'-Pentachlorobiphenyl
32598-14-4	105	2,3,3',4,4'-Pentachlorobiphenyl
70424-69-0	106	2,3,3',4,5-Pentachlorobiphenyl
70424-68-9	107	2,3,3',4',5-Pentachlorobiphenyl
70362-41-3	108	2,3,3',4,5'-Pentachlorobiphenyl
74472-35-8	109	2,3,3',4,6-Pentachlorobiphenyl
38380-03-9	110	2,3,3',4',6-Pentachlorobiphenyl
39635-32-0	111	2,3,3',5,5'-Pentachlorobiphenyl
74472-36-9	112	2,3,3',5,6-Pentachlorobiphenyl
68194-10-5	113	2,3,3',5',6-Pentachlorobiphenyl
74472-37-0	114	2,3,4,4',5-Pentachlorobiphenyl
74472-38-1	115	2,3,4,4',6-Pentachlorobiphenyl
18259-05-7	116	2,3,4,5,6-Pentachlorobiphenyl

**Table G-3 (cont.). Summary of PCB Congeners**

<b>CASRN</b>	<b>Congener Number</b>	<b>IUPAC Name</b>
68194-11-6	117	2,3,4',5,6-Pentachlorobiphenyl
31508-00-6	118	2,3',4,4',5-Pentachlorobiphenyl
56558-17-9	119	2,3',4,4',6-Pentachlorobiphenyl
68194-12-7	120	2,3',4,5,5'-Pentachlorobiphenyl
56558-18-0	121	2,3',4,5',6-Pentachlorobiphenyl
76842-07-4	122	2,3,3',4',5'-Pentachlorobiphenyl
65510-44-3	123	2,3',4,4',5'-Pentachlorobiphenyl
70424-70-3	124	2,3',4',5,5'-Pentachlorobiphenyl
74472-39-2	125	2,3',4',5',6-Pentachlorobiphenyl
57465-28-8	126	3,3',4,4',5-Pentachlorobiphenyl
39635-33-1	127	3,3',4,5,5'-Pentachlorobiphenyl
38380-07-3	128	2,2',3,3',4,4'-Hexachlorobiphenyl
55215-18-4	129	2,2',3,3',4,5-Hexachlorobiphenyl
52663-66-8	130	2,2',3,3',4,5'-Hexachlorobiphenyl
61798-70-7	131	2,2',3,3',4,6-Hexachlorobiphenyl
38380-05-1	132	2,2',3,3',4,6'-Hexachlorobiphenyl
35694-04-3	133	2,2',3,3',5,5'-Hexachlorobiphenyl
52704-70-8	134	2,2',3,3',5,6-Hexachlorobiphenyl
52744-13-5	135	2,2',3,3',5,6'-Hexachlorobiphenyl
38411-22-2	136	2,2',3,3',6,6'-Hexachlorobiphenyl
35694-06-5	137	2,2',3,4,4',5-Hexachlorobiphenyl
35065-28-2	138	2,2',3,4,4',5'-Hexachlorobiphenyl
56030-56-9	139	2,2',3,4,4',6-Hexachlorobiphenyl
59291-64-4	140	2,2',3,4,4',6'-Hexachlorobiphenyl
52712-04-6	141	2,2',3,4,5,5'-Hexachlorobiphenyl
41411-61-4	142	2,2',3,4,5,6-Hexachlorobiphenyl
68194-15-0	143	2,2',3,4,5,6'-Hexachlorobiphenyl
68194-14-9	144	2,2',3,4,5',6-Hexachlorobiphenyl
74472-40-5	145	2,2',3,4,6,6'-Hexachlorobiphenyl
51908-16-8	146	2,2',3,4',5,5'-Hexachlorobiphenyl
68194-13-8	147	2,2',3,4',5,6-Hexachlorobiphenyl
74472-41-6	148	2,2',3,4',5,6'-Hexachlorobiphenyl
38380-04-0	149	2,2',3,4',5',6-Hexachlorobiphenyl
68194-08-1	150	2,2',3,4',6,6'-Hexachlorobiphenyl
52663-63-5	151	2,2',3,5,5',6-Hexachlorobiphenyl
68194-09-2	152	2,2',3,5,6,6'-Hexachlorobiphenyl
35065-27-1	153	2,2',4,4',5,5'-Hexachlorobiphenyl
60145-22-4	154	2,2',4,4',5,6'-Hexachlorobiphenyl
33979-03-2	155	2,2',4,4',6,6'-Hexachlorobiphenyl

**Table G-3 (cont.). Summary of PCB Congeners**

<b>CASRN</b>	<b>Congener Number</b>	<b>IUPAC Name</b>
38380-08-4	156	2,3,3',4,4',5-Hexachlorobiphenyl
69782-90-7	157	2,3,3',4,4',5'-Hexachlorobiphenyl
74472-42-7	158	2,3,3',4,4',6-Hexachlorobiphenyl
39635-35-3	159	2,3,3',4,5,5'-Hexachlorobiphenyl
41411-62-5	160	2,3,3',4,5,6-Hexachlorobiphenyl
74472-43-8	161	2,3,3',4,5',6-Hexachlorobiphenyl
39635-34-2	162	2,3,3',4',5,5'-Hexachlorobiphenyl
74472-44-9	163	2,3,3',4',5,6-Hexachlorobiphenyl
74472-45-0	164	2,3,3',4',5',6-Hexachlorobiphenyl
74472-46-1	165	2,3,3',5,5',6-Hexachlorobiphenyl
41411-63-6	166	2,3,4,4',5,6-Hexachlorobiphenyl
52663-72-6	167	2,3',4,4',5,5'-Hexachlorobiphenyl
59291-65-5	168	2,3',4,4',5',6-Hexachlorobiphenyl
32774-16-6	169	3,3',4,4',5,5'-Hexachlorobiphenyl
35065-30-6	170	2,2',3,3',4,4',5-Heptachlorobiphenyl
52663-71-5	171	2,2',3,3',4,4',6-Heptachlorobiphenyl
52663-74-8	172	2,2',3,3',4,5,5'-Heptachlorobiphenyl
68194-16-1	173	2,2',3,3',4,5,6-Heptachlorobiphenyl
38411-25-5	174	2,2',3,3',4,5,6'-Heptachlorobiphenyl
40186-70-7	175	2,2',3,3',4,5',6-Heptachlorobiphenyl
52663-65-7	176	2,2',3,3',4,6,6'-Heptachlorobiphenyl
52663-70-4	177	2,2',3,3',4,5',6'-Heptachlorobiphenyl
52663-67-9	178	2,2',3,3',5,5',6-Heptachlorobiphenyl
52663-64-6	179	2,2',3,3',5,6,6'-Heptachlorobiphenyl
35065-29-3	180	2,2',3,4,4',5,5'-Heptachlorobiphenyl
74472-47-2	181	2,2',3,4,4',5,6-Heptachlorobiphenyl
60145-23-5	182	2,2',3,4,4',5,6'-Heptachlorobiphenyl
52663-69-1	183	2,2',3,4,4',5',6-Heptachlorobiphenyl
74472-48-3	184	2,2',3,4,4',6,6'-Heptachlorobiphenyl
52712-05-7	185	2,2',3,4,5,5',6-Heptachlorobiphenyl
74472-49-4	186	2,2',3,4,5,6,6'-Heptachlorobiphenyl
52663-68-0	187	2,2',3,4',5,5',6-Heptachlorobiphenyl
74487-85-7	188	2,2',3,4',5,6,6'-Heptachlorobiphenyl
39635-31-9	189	2,3,3',4,4',5,5'-Heptachlorobiphenyl
41411-64-7	190	2,3,3',4,4',5,6-Heptachlorobiphenyl
74472-50-7	191	2,3,3',4,4',5',6-Heptachlorobiphenyl
74472-51-8	192	2,3,3',4,5,5',6-Heptachlorobiphenyl
69782-91-8	193	2,3,3',4',5,5',6-Heptachlorobiphenyl
35694-08-7	194	2,2',3,3',4,4',5,5'-Octachlorobiphenyl

**Table G-3 (cont.). Summary of PCB Congeners**

<b>CASRN</b>	<b>Congener Number</b>	<b>IUPAC Name</b>
52663-78-2	195	2,2',3,3',4,4',5,6-Octachlorobiphenyl
42740-50-1	196	2,2',3,3',4,4',5,6'-Octachlorobiphenyl
33091-17-7	197	2,2',3,3',4,4',6,6'-Octachlorobiphenyl
68194-17-2	198	2,2',3,3',4,5,5',6-Octachlorobiphenyl
52663-75-9	199	2,2',3,3',4,5,5',6'-Octachlorobiphenyl
52663-73-7	200	2,2',3,3',4,5,6,6'-Octachlorobiphenyl
40186-71-8	201	2,2',3,3',4,5',6,6'-Octachlorobiphenyl
2136-99-4	202	2,2',3,3',5,5',6,6'-Octachlorobiphenyl
52663-76-0	203	2,2',3,4,4',5,5',6-Octachlorobiphenyl
74472-52-9	204	2,2',3,4,4',5,6,6'-Octachlorobiphenyl
74472-53-0	205	2,3,3',4,4',5,5',6-Octachlorobiphenyl
40186-72-9	206	2,2',3,3',4,4',5,5',6-Nonachlorobiphenyl
52663-79-3	207	2,2',3,3',4,4',5,6,6'-Nonachlorobiphenyl
52663-77-1	208	2,2',3,3',4,5,5',6,6'-Nonachlorobiphenyl
2051-24-3	209	Decachlorobiphenyl