

2018 Federal Duck Stamp Art Contest

Information, Entry Form and Regulations

Dear Artist:

Please read all of the enclosed information very carefully and follow the instructions. If you do not follow the instructions completely, your entry may be disqualified from the contest.

All entries must be postmarked by midnight August 15, 2018.



2017 Federal Duck Stamp Contest
Winner Artist: Robert Hautman
Species: Mallard

Please submit your entry to:

Federal Duck Stamp Contest
U.S. Fish & Wildlife Service
Duck Stamp Office MS:MB
5275 Leesburg Pike
Falls Church, VA 22041

Summary of Key Points

Who can enter the Federal Duck Stamp Contest?

All U.S. citizens, nationals or resident aliens are eligible to participate. However, all entrants must be at least 18 years of age by June 1. Contest judges and their relatives, and employees of the Federal Duck Stamp Office are ineligible to submit entries.

Why do you have a contest?

The Federal Duck Stamp Contest is mandated by law and carried out by the U.S. Fish and Wildlife Service. It offers this country's wildlife artists the opportunity to have their designs considered to grace the Federal Duck Stamp. Winning the Federal Duck Stamp Contest not only lends prestige to the chosen artist, but also can serve as a catalyst in building a successful career in wildlife art.

What can I send to the contest?

A Federal Duck Stamp Contest art entry consists of a two-dimensional design. The regulations for the contest do not specify a medium.

Judges are instructed to look for scenes depicting live birds in their natural habitat. **In 2018 judges will also be instructed to choose a scene that will best illustrate the theme "celebrating our waterfowl hunting heritage." It will be mandatory for your image to include one or more appropriate hunting-related accessories and/or themes that reflect this.** This could include decoys, dogs, hunting blinds or other hunting images. Only five species of waterfowl are allowed each year for consideration. The eligible species must be the dominant feature in the design and must be alive. This means it must be noticeably larger than any other elements you may wish to include.

Judges will also be looking for images that will reproduce well as a stamp.

Each entry must be accompanied by the Display, Participation & Reproduction Rights Agreement (see page 7) and an entry fee of \$125. The fee must be a **certified check, cashier's check, or money order** made payable to the U.S. Fish & Wildlife Service. No personal checks or cash will be accepted. *If you send a personal check or cash your painting will be disqualified.*

Entries must be uniform in size. Each entry must be 7" x 10" and matted over with bright white matting. The matting must be 1" wide. Total size (entry with matting) must be 9" x 12". (See the diagram on page 5.) We recommend you use a 1/8" masonite board or foamcore with 1/8" matting to equal the total width of 1/4" thick. Any entry exceeding 1/4" thick will be disqualified.

When do I send in my entry?

Entries are accepted beginning June 1 of each year and must be postmarked no later than midnight on August 15. There is no exception made for holidays and weekends. Entries are cataloged and assigned numbers based on date of receipt in the Federal Duck Stamp Office. Entries will be returned after the contest in packaging determined by the Federal Duck Stamp Office. No packaging materials will be returned.

Where do I send my entry?

All entries must be sent to the address listed below:

Federal Duck Stamp Contest
U.S. Fish & Wildlife Service MS:MB
5275 Leesburg Pike
Falls Church, VA 22041

How do I prepare my entry?

Each artist should have a working knowledge in three major areas of special interest to Federal Duck Stamp Contest judges:

- Basic Waterfowl Biology—for example, if you choose to depict a spring scene, is the bird's plumage correct for that season?
- Artistic Composition—is the image artistically interesting and does it "pop" when you look at it?
- Suitability for printing at a reduced size—the image provides the design for a 1 3/4" L x 1 1/2" W stamp. Considering the amount of detail you wish to include, do you think it will show well in this reduced size?

What are the eligible species for this year?

- Wood Duck
- American Wigeon
- Northern Pintail
- Green-winged Teal
- Lesser Scaup

What does the winning artist receive?

The artist will receive publicity and media recognition. He/she will also travel and be recognized as guest speaker at several prestigious national waterfowl festivals and wildlife art events. The artist receives a pane of his or her Duck Stamps signed by the Secretary of the Interior. Finally, the winner can choose to market the winning image and any other works as "by the Federal Duck Stamp artist." (Note: Any publishing contract that might be offered to the winning artist is between the artist and publisher. The Federal Government does not guarantee any contract will be offered. The Government assumes no liability, responsibility, nor claims any interest in resulting publishing contracts.)

Why is this important and why should I enter?

The Federal Duck Stamp Program raises approximately \$40 million each year to help protect vital wetland habitat in our National Wildlife Refuge System. Since 1934, the sale of Federal Duck Stamps has raised more than \$1 billion to help purchase almost 6 million acres of wetlands, land that everyone can enjoy for generations to come. Enter the contest and you may become a part of this legacy. Each entry exemplifies art for conservation's sake.

Design Checklist for 2018

Have you included one or more of the 2018 eligible species? Is it alive and the dominant part of your entry?

Have you included an appropriate hunting-related accessory or scene that illustrates the theme "celebrating our waterfowl hunting heritage"?

Is your entry free of all writing on its face? This includes bird band numbers and signatures!!! No writing is allowed on the front of your entry.

Contest Regulations

PART 91—MIGRATORY BIRD HUNTING AND CONSERVATION STAMP CONTEST

Subpart A—Introduction

Sec.

- 91.1 Purpose of regulations.
- 91.2 Definitions.
- 91.3 Public attendance at contest.
- 91.4 Eligible species.

Subpart B—Procedures for Entering the Contest

- 91.11 Contest deadlines.
- 91.12 Contest eligibility.
- 91.13 Technical requirements for design and submission of entry.
- 91.14 Restrictions on subject matter of entry.
- 91.16 Submission procedures for entry.
- 91.17 Property insurance for entries.
- 91.18 Failure to comply with contest regulations.

Subpart C—Procedures for Administering the Contest

- 91.21 Selection and qualification of contest judges.
- 91.22 Display of entries for contest.
- 91.23 Scoring criteria for contest.
- 91.24 Contest procedures.

Subpart D—Post-Contest Procedures

- 91.31 Return of entries after contest.

Authority: 5 U.S.C. 301; 16 U.S.C. 718j; 31 U.S.C. 9701.

SUBPART A—INTRODUCTION

§91.1 Purpose of regulations.

(a) The purpose of these regulations is to establish procedures for selecting a design that will be used for the annual Migratory Bird Hunting and Conservation Stamp (Federal Duck Stamp).

(b) All individuals entering the contest must comply with these regulations. A copy of the regulations along with the reproduction rights and display and participation agreements may be requested from the Federal Duck Stamp Office, U.S. Fish & Wildlife Service MS:MB, 5275 Leesburg Pike, Falls Church, VA 22041.

§91.2 Definitions.

Contest Coordinator—the contest official responsible for overseeing the judges' scores for each entry. The contest coordinator will be named by the Secretary of the Interior and will not be a past or present employee of the Fish and Wildlife Service.

Display and participation agreement—a document that each contestant must complete, sign and submit with the entry. The signed agreement permits the Service to display the entry at various locations for promotional purposes, and requires the artist to participate in events on behalf of the Federal Duck Stamp Program.

Qualifying entry—each original work of art submitted to the contest that satisfies the requirements outlined in Subpart B.

Reproduction rights agreement—a document that each contestant must sign and submit with the entry. The signed agreement certifies that the entry is an original work of art and stipulates how the Fish and Wildlife Service may use the winning entry.

§91.3 Public attendance at contest.

All phases of the voting process will be open for viewing by the general public.

§91.4 Eligible species.

Five or fewer of the species listed below will be identified as eligible each year, those eligible species will be provided to each contestant with the information provided in §91.1.

- (a) **Whistling-Ducks.**
 - (1) Fulvous Whistling-Duck (*Dendrocygna bicolor*)
 - (2) Black-bellied Whistling-Duck (*Dendrocygna autumnalis*)
- (b) **Geese.**
 - (1) Emperor Goose (*Anser canagica*)
 - (2) Snow Goose (including "white" and "blue" morphs) (*Anser caerulescens*)
 - (3) Ross' Goose (*Anser rossii*)
 - (4) Greater White-fronted Goose (*Anser albifrons*)
 - (5) Brant (*Branta bernicla*)
 - (6) Cackling Goose (*Branta hutchinsii*)
 - (7) Canada Goose (*Branta canadensis*)
- (c) **Swans.**
 - (1) Trumpeter Swan (*Cygnus buccinator*)
 - (2) Tundra Swan (*Cygnus columbianus*)
- (d) **Dabbling Ducks.**
 - (1) Wood Duck (*Aix sponsa*)
 - (2) Blue-winged Teal (*Spatula discors*)
 - (3) Cinnamon Teal (*Spatula cyanoptera*)
 - (4) Northern Shoveler (*Spatula clypeata*)
 - (5) Gadwall (*Mareca strepera*)
 - (6) American Widgeon (*Mareca americana*)
 - (7) Mallard (*Anas platyrhynchos*)
 - (8) American Black Duck (*Anas rubripes*)
 - (9) Mottled Duck (*Anas fulvigula*)
 - (10) Northern Pintail (*Anas acuta*)
 - (11) Green-winged Teal (*Anas creca*)
- (e) **Diving Ducks.**
 - (1) Canvasback (*Aythya valisineria*)
 - (2) Redhead (*Aythya americana*)
 - (3) Ring-necked Duck (*Aythya collaris*)
 - (4) Greater Scaup (*Aythya marila*)
 - (5) Lesser Scaup (*Aythya affinis*)
- (f) **Sea-Ducks.**
 - (1) Steller's Eider (*Polysticta stelleri*)
 - (2) Spectacled Eider (*Somateria fischeri*)
 - (3) King Eider (*Somateria spectabilis*)
 - (4) Common Eider (*Somateria mollissima*)
 - (5) Harlequin Duck (*Histrionicus histrionicus*)
 - (6) Surf Scoter (*Melanitta perspicillata*)
 - (7) White-winged Scoter (*Melanitta fusca*)
 - (8) Black Scoter (*Melanitta americana*)
 - (9) Long-tailed Duck (*Clangula hyemalis*)
 - (10) Bufflehead (*Bucephala albeola*)
 - (11) Common Goldeneye (*Bucephala clangula*)
 - (12) Barrow's Goldeneye (*Bucephala islandica*)

(h) **Mergansers.**

- (1) Hooded Merganser (*Lophodytes cucullatus*)
- (2) Common Merganser (*Mergus merganser*)
- (3) Red-breasted Merganser (*Mergus serrator*)

(i) **Stiff Tails.**

- (1) Ruddy Duck (*Oxyura jamaicensis*)

SUBPART B—PROCEDURES FOR ENTERING THE CONTEST

§91.11 Contest opening date and entry deadline.

The contest officially opens on June 1 of each year. Entries must be postmarked no later than midnight, August 15.

§91.12 Contest eligibility.

United States citizens, nationals, or resident aliens are eligible to participate in the contest. Any person who has won the federal contest during the preceding three years will not be eligible to submit an entry in the current year's contest. All entrants must be 18 years of age as of June 1 to participate in the Federal Duck Stamp Contest. Contest judges and their relatives are ineligible to submit an entry. All entrants must submit a non-refundable fee of \$125.00 by a cashier's check, certified check, or money order made payable to: U.S. Fish and Wildlife Service. **(Personal checks will not be accepted.) All entrants must submit signed Reproduction Rights and Display and Participation Agreements.**

§91.13 Technical requirements for design and submission of entry.

The design must be a horizontal drawing or painting seven (7) inches high and ten (10) inches wide. The entry may be drawn in any medium desired by the contestant and may be in either multicolor or black and white. No scrollwork, lettering, bird band numbers, signatures or initials may appear on the design. Each entry must be matted (over only) with a nine (9) inch by twelve (12) inch white mat, one (1) inch wide, and the entire entry cannot exceed one quarter (1/4) inch in total thickness. Entries must not be framed, under glass, or have a protective covering that is attached to the entry.

§91.14 Restrictions on subject matter of entry.

(a) **A live portrayal of any bird(s) of the five or fewer identified eligible waterfowl species must be the dominant feature of the design. The design may depict more than one of the eligible species. The judges' overall mandate is to select the best design that will make an interesting, useful, and attractive duck stamp that will be accepted and prized by hunters, stamp collectors, conservationists, and others. The design must be the contestant's original hand-drawn creation. The entry design may not be copied or duplicated from previously published art, including photographs, or from images in any format published on the Internet. Photographs, computer-generated art, or art produced from a computer printer**

or other computer/mechanical output device (airbrush method excepted) are not eligible to be entered into the contest and will be disqualified. An entry submitted in a prior contest that was not selected for a Federal or State stamp design may be submitted in the current contest if the entry meets the criteria set forth in this section.

(b) In addition to the restrictions set forth in paragraph (a), in 2018 only, designs will also be required to include appropriate hunting-related accessories and/or scenes celebrating the Federal Duck Stamp's long-standing connection as part of our Nation's waterfowl hunting heritage and the contributions to conservation made by waterfowl hunters. Designs may include, but are not limited to, hunting dogs, hunting scenes, hunting equipment, waterfowl decoys, managed waterfowl areas as the background of habitat scenes, or other designs that represent our waterfowl hunting heritage. The design chosen will clearly meet the theme of "celebrating our waterfowl hunting heritage."

§91.16 Submission procedures for entry.

(a) Each contestant may submit only one entry. Each entry must be accompanied by a non-refundable entrance fee and a completed and signed Reproduction Rights Agreement and a completed and signed Display and Participation Agreement. The bottom portion of the Reproduction Rights Agreement must be attached to the back of the entry.

(b) *Each entry should be appropriately wrapped to protect the artwork and sent by registered mail, certified mail, express mail, overnight delivery service, or hand delivered to:*

*Federal Duck Stamp Contest
U.S. Fish & Wildlife Service MS:MB
5275 Leesburg Pike
Falls Church, VA 22041*

§91.17 Property insurance for entries.

Each contestant is responsible for obtaining adequate insurance coverage for his/her entry. The Department of the Interior will not insure the entries it receives. The Department of the Interior is not responsible for loss or damage unless it is caused by its negligence or willful misconduct; in any event, the liability of the Department of the Interior will not exceed the amount of the entry fee as specified in Section 91.12.

§91.18 Failure to comply with contest regulations.

Any entry that does not comply with the requirements of Subpart B will be disqualified from the contest. Entry fees for disqualified entries will not be returned.

SUBPART C—PROCEDURES FOR ADMINISTERING THE CONTEST

§91.21 Selection and qualification of contest judges.

(a) *Selection:* Five voting judges and one alternate judge will be selected annually by the Secretary of the Interior. Current employ-ees of the Fish and Wildlife Service and their relatives are ineligible to serve as judges for the contest. The judges will be reimbursed for reasonable travel expenses. The judges will be announced on

the first day of the contest.

(b) Qualifications:

(1) The panel of five judges will be made up of individuals, all of whom have one or more of the following prerequisites: recognized art credentials, knowledge of the anatomical make up and the natural habitat of the eligible waterfowl species, an understanding of the wildlife sporting world in which the Duck Stamp is used, an awareness of philately and the role the Duck Stamp plays in stamp collecting, and demonstrated support for the conservation of waterfowl and wetlands through active involvement in the conservation community.

(2) In 2018 only it will also be mandatory that all selected judges have an understanding and appreciation of the waterfowl hunting heritage and be able to recognize waterfowl hunting accessories.

§91.22 Display of entries for contest.

All eligible entries will be publicly displayed in numerical order. The only visible identification on each entry will be the number assigned to it in chronological order when it is received and processed by the Service.

§91.23 Scoring criteria for contest.

(a) Entries will be judged on the basis of anatomical accuracy, artistic composition and suitability for reduction in the production of a stamp.

(b) In 2018 only, it will also be mandatory that all selected judges have an understanding and appreciation of the waterfowl hunting heritage and be able to recognize waterfowl hunting accessories.

§91.24 Contest procedures.

(a) The day before the judging begins, the judges will be briefed on all aspects of the judging procedures and other details of the competition, and will preview all eligible artwork entered.

(b) Prior to the first round of judging, and prior to the opening of the contest to the public, the judges will spend additional time in the auditorium reviewing the entries on the day of the contest.

(c) In the first round of judging all qualified entries will be shown one at a time to the judges by the Contest Coordinator or a contest staff member. The judges will vote "in" or "out" on each entry; those entries receiving a majority of votes "in" will be eligible for the second round of judging. The remaining entries will be placed on display as a group for public viewing.

(d) Prior to the second round of judging, each judge may select not more than five entries from those eliminated in the first round. Those additional entries selected by the judges will be eligible to be judged in the second round.

(e) Prior to the second round of judging, the entries selected by the judges under the procedures of paragraphs (c) and (d) of this section will be displayed in numerical order in the front of the auditorium.

(f) The technical advisors from the Department of the Interior and the U.S. Postal Service will do a critical analysis of the entries that will be judged in the second round and advise the judges of any serious anatomical problems.

(g) In the second round of judging, each entry selected in the first round, plus the additional entries selected by judges, will be shown one at a time to the judges by the Contest Coordinator or by a contest staff member. The judges will vote by indicating a numerical score from one to five for each entry. The scores will be totaled to provide the entry score. The entries receiving the five highest scores will be advanced to the third round of judging.

(h) In the third round of judging, the judges will vote on the remaining entries using the same method as in round two, except they will indicate a numerical score from 3 to 5 for each entry. The Contest Coordinator will tabulate the final votes and present them to the Director, U.S. Fish and Wildlife Service, who will announce the winning entry as well as the entries that placed second and third.

(i) In case of a tie vote for first, second, or third place in the third round, the judges will vote again on the entries that are tied. The judges will vote using the same method as in round three.

(j) The selection of the winning entry by the judges will be final. Each contestant will be notified of the winning artist and the design. The winning artist will receive a pane of Duck Stamps, or similar quality memento portraying their current Federal Duck Stamp, signed by the Secretary of the Interior at the Federal Duck Stamp Contest the following year. At the discretion of the Service, other artists who substantially assist with the design of the final stamp will receive formal recognition during the following year's contest. At the discretion of the Service, artists placing in Round 3 may receive a nonmonetary award to acknowledge their participation and success in this prestigious art contest.

SUBPART D—POST-CONTEST PROCEDURES

§91.31 Return of entries after contest.

All entries will be returned by commercial shipping service to the participating artists within 120 days after the contest unless the artwork is selected to appear at one or more wildlife art expositions. Entries will be returned in packaging determined by the Federal Duck Stamp Office. No specialty boxes or art cases will be returned. If artwork is returned to the Service because it is unde-livered or unclaimed (this may happen if an artist changes address), the Service will not be obligated to trace the location of the artist to return the artwork. Any artist who changes his or her address is responsible for notifying the Service of the change. All unclaimed entries will be destroyed one year from the date of the contest.

Duck Stamp Contest Submission Format

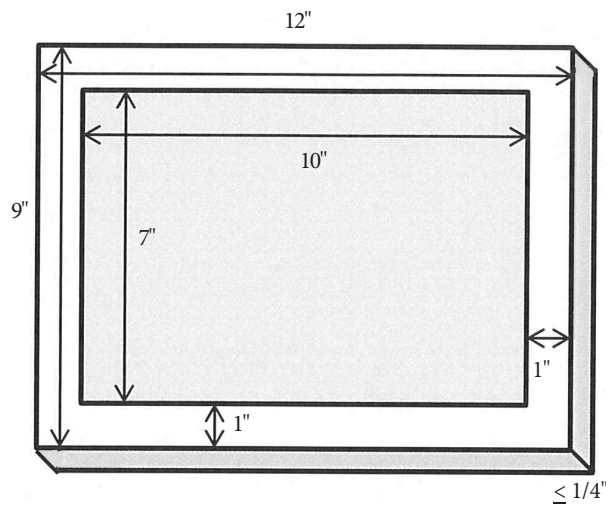

Entry must be matted "over" and the matting affixed to the front of the painting. The painting will be placed in a carrier that carries the information on the back of the painting to provide anonymity. In order to ensure that we are able to place the paintings in the carriers, do not make your entry any thicker than 1/4" or it will be disqualified.

Suggestion: Use a 1/8" thick Masonite or foamcore for your entry, then use a 1/8" thick mat to place on top to form 1/4" total thickness of entry.

Also, for purposes of stability of the entry, please use a 9" x 12" art board with a 9" x 12" mat, rather than a 7" x 10" art board covered by a 9" x 12" mat.

Be sure to allow ample time, prior to shipping, for varnish and paint to fully dry to avoid damage to your artwork.

When mailing your entry to the Federal Duck Stamp Office, please pack your artwork carefully and use stiff packing material to ensure that the art will not be bent or damaged in transit. Bubble wrap or bubble wrap mailing pouches should be placed in hard sided boxes to protect artwork. It is recommended that you ship your package through a shipping company that provide tracking services.

Eligible species for upcoming Federal Duck Stamp Contests will be decided and posted online no later than January 1 of the Contest year for which they will be judged.

Display and Participation Agreement

The Fish and Wildlife Service (FWS) continues to promote greater public awareness of the Federal Duck Stamp and its many contributions to wetland and waterfowl conservation. To assist in and facilitate this promotional effort, the FWS has sought out the participation and cooperation of various wildlife oriented art exhibitors for the purpose of displaying selected entries during the year following the contest. The artist's name, city, and state will be shown next to each entry. No effort will be made to sell any entry. If an artist's entry is selected to be on display, it may mean that the entry will not be returned to the artist within the 120 days after the contest in which all other entries are normally returned.

Approximately 20 of the highest ranked entries from the Federal Duck Stamp Contest may appear on display at special events throughout the country. Please check our web site at <http://www.fws.gov/birds/get-involved/duck-stamp/federal-duck-stamp-art-exhibit-tour.php> for the latest touring exhibit schedule.

The winning artist must agree to participate in the following events to help promote the Federal Duck Stamp Program. Some transportation and lodging will be paid by the organizations indicated.

Easton Waterfowl Festival, Easton, MD — *the second full weekend of November*. The festival will pay for lodging; the Federal Duck Stamp Program will pay for transportation. *Four days.*
www.waterfowlfestival.org

The Wildlife Art Festival, San Bernardino County, CA, mid-November.
The festival will pay for transportation and lodging. *Three days.*

National Junior Duck Stamp Art Contest, mid-April.
The Federal Duck Stamp Program will pay for transportation and lodging according to current Federal Government per diem rates. *One day.*

First Day Ceremony, approximately the end of June – July 1.
The Federal Duck Stamp Program will pay for transportation and lodging according to current Federal Government per diem rates. *One day.*

Artist's Hometown Event, date and location to be determined. All expenses paid by the artist or partners.

Following Year Federal Duck Stamp Contest, date and location to be determined.
The Federal Duck Stamp Program will pay for transportation and lodging according to current Federal Government per diem rates. *Three days.*

J.N. "Ding" Darling Birthday Event, J.N. "Ding" Darling National Wildlife Refuge, Sanibel, FL — mid-October. The J.N. "Ding" Darling Society will pay for transportation. Lodging is at the artist's expense.
www.dingdarlingsociety.org/dingdarlingdays

The winning artist may be asked to participate in several annual stamp events at the artist's expense to support the Federal Duck Stamp Program.

The winning artist may be asked to make brief remarks at several events to promote the Federal Duck Stamp Program.

It is required at a minimum, that the artist spend one peak attendance day (as determined by the Federal Duck Stamp Office) at each of these events.

The winning artist will assist in promoting the Federal Duck Stamp Program by providing autographs without charge to the public or the Federal Government.

The Federal Government will assume no responsibility for the safekeeping or loss of the entries once accepted by the management of the exhibitions and until returned from the exhibitions to Government custody. **It is strongly suggested that each artist insure his/her art before sending it to the Federal Duck Stamp Office.**

The winning artist will be required to provide the following artwork by February (a) a line drawing for the postal cancellation for the first day of sale of the Federal Duck Stamp; (b) if the artist decides to have a hometown sales event, another line drawing will be required for the postal cancellation for that event; (c) two remarques to be depicted on the first and third year of the individual Artist's Appreciation Card.

Signature on this agreement is a prerequisite for entering any Federal Duck Stamp Contest; failure to sign will result in the disqualification of your entry.

NOTE: All requirements cited above will be subject to negotiation when extenuating circumstances exist for the artist. Although all extenuating circumstances are not listed in this document, some examples are: (1) health of the artist does not permit the artist to travel to some or any of the events identified; (2) the home of the artist is located in an area so remote as to make attendance at the scheduled event impossible; and (3) emergencies prohibit the artist from participating.

2018 Display, Participation & Rights Reproduction Agreement

The undersigned Artist, who has prepared and submitted an original design to the Federal Duck Stamp Contest, U.S. Fish & Wildlife Service, 4401 North Fairfax Drive, Mailstop MBSP-4070, Arlington, VA 22203-1622, as an entry in the annual contest for the 2011-2012 Migratory Bird Hunting and Conservation Stamp agrees to the following conditions concerning display, participation and reproduction rights if his/her design is selected for the stamp:

1. I agree that my entry in the Federal Duck Stamp Contest may be displayed at the Fish and Wildlife Service's discretion and for the purpose of promoting public awareness of the Federal Duck Stamp Program and its contributions to waterfowl conservation, under the conditions described in the Display and Participation Agreement and waive any claims for damage or loss that might otherwise lie against the United States Government during the time my entry is in the custody of the managements of those exhibitions.

2. I understand that if my entry is selected for display, it may not be returned to me within the 120 day period stipulated in the regulations. Further, I agree that in the event I am the winning artist in the Federal Duck Stamp Contest, I will participate in the events as stipulated in the Display and Participation Agreement.

3. The design, as prepared by the Artist and submitted to the FWS, may be retained by the FWS until the modeling and printing of the Migratory Bird Hunting and Conservation Stamp has been completed. The stamp design based on the Artist's original design may be copied and reproduced, and copies and reproductions may be published and distributed by the FWS to others for reproduction, copying and publishing for educational

or informational purposes. In addition, the stamp design may be made available, without compensation to the Artist, for reproduction for commercial and other purposes pursuant to 16 U.S.C. Section 718e(c).

4. Ownership of the original design may, at the option of the Artist, be retained by him/her and it may be copyrighted, copied, reproduced, published, or otherwise distributed by the Artist, but any copyright of the design or any agreement made by the Artist with any other person or company covering the use of the design expressly shall be made subject to the rights of the FWS under paragraph 1 of this Agreement.

5. If the Artist decides to reproduce the original artwork in the form of prints, he/she agrees to provide at no cost twenty-five (25) to the FWS. The prints will be retained by the Director of the FWS and will be used to promote the Federal Duck Stamp Program.

6. If the Artist and/or his/her publisher decide to reproduce the original artwork in the form of mini prints, decoys, postcards, and other sales items, he/she agrees to provide at no cost ten of any one of the articles to the FWS. (The FWS shall choose which item.) The items will be used to promote the Federal Duck Stamp Program.

7. If the Artist and/or his/her publisher decide to reproduce the original artwork in the form of posters, he/she agrees to provide the FWS with 200 posters at no cost. The posters will be used to promote the Federal Duck Stamp Program.

8. Any and all reproduction of either the original design or the stamp design made or authorized by the FWS under the terms of this Agreement, except the modeling and printing of the Migratory Bird Hunting and Conservation Stamp, and reproductions thereof authorized pursuant to 16 U.S.C. Section 718e(c),

specifically shall indicate that the original has been designed by the Artist.

9. The Artist affirms that his/her entry is a drawing of his/her own creation, neither copied nor duplicated from previously published art, including paintings, drawings in any medium, or published photograph; or from images of any kind previously published on the Intranet.

10. The Artist agrees that if selected for the stamp, the Artist's original design will be used by the stamp printer as the basis for creating the stamp design, and agrees that in doing so, changes may be made to the Artist's original design at the discretion of the stamp printer.

11. It is mutually agreed that no Member or Delegate to Congress shall participate in any part of the contract/agreement or receive any benefit from this agreement (41 U.S.C. Section 22).

12. The Artist agrees to provide his/her signature for use on all Stamp products at no cost to the Federal Government.

13. The information below will be contained in an electronic database maintained by the FWS and will not be used by the FWS for any purpose other than to register the Artist, or, if needed, to respond to a public information request under the Freedom of Information Act (FOIA).

NOTE: The fields marked below with an asterisk (*) are the only required fields. The Artist may provide additional information they deem necessary so that the FWS may contact him/her, it is not required by the FWS to participate. Out of respect for your privacy, FWS collects only the minimum information necessary and does not share information outside the FWS.

Artist Signature

Failure to sign this form will result in disqualification

| | | |
|-----------------------|-----------------|----------|
| *Street Address | (No P.O. Boxes) | *Date |
| _____ | | _____ |
| *City, State, and Zip | | *Species |
| _____ | | _____ |
| *Telephone (Home) | | |
| _____ | | |

In accordance with the Paperwork Reduction Act (44 U.S.C. 3501), the U.S. Fish and Wildlife Service collects information necessary to consider your submission for the Federal Duck Stamp Contest. Information requested in this form is purely voluntary. Failure to provide all required information may be sufficient cause for the U.S. Fish and Wildlife Service to reject your submission. According to the Paperwork Reduction Act of 1995, an agency may not conduct or sponsor and a person is not required to respond to a collection of information unless it displays a currently valid OMB control number. OMB has approved this collection of information and assigned Control No. 1018-####. We estimate public reporting for this collection of information to average 5 minutes, including time for reviewing instructions, gathering and maintaining data and completing and reviewing the form. Direct comments regarding the burden estimate or any other aspect of the form to the Service Information Clearance Officer, Fish and Wildlife Service, U.S. Department of the Interior, 5275 Leesburg Pike, MS: BPHC, Falls Church, VA 22041-3803, or via email at Info_Coll@fws.gov. Please do not send your completed form to this address.

Entry Form for 2018 Federal Duck Stamp Contest

Attach this part to the back of your entry, and send your entry, entry fee and the Display, Participation & Reproduction Rights Agreement to: **Federal Duck Stamp Contest, U.S. Fish & Wildlife Service MS:MB, 5275 Leesburg Pike, Falls Church, VA 22041.**

OMB Control No. 1018-####
Expiration Date ##/##/####

To be used by FWS only

Entry Number

Print or Type

| | | |
|-----------------------|-----------------|----------------|
| *Name | | *Species |
| _____ | | _____ |
| *Street Address | (No P.O. Boxes) | *Medium Used |
| _____ | | _____ |
| *City, State, and Zip | | |
| _____ | | |
| *Telephone (Home) | (Work) | (Cell) |
| _____ | | _____ |
| Email Address | | *Date of Birth |
| _____ | | _____ |
| | | MONTH YEAR |

Press Coverage: Name of Hometown Newspaper

Enclosed find \$125 non-refundable entry fee in the form of a cashier's check, certified check, or money order, payable to: U.S. Fish & Wildlife Service. Personal checks and/or cash are NOT accepted.

Postmark by midnight August 15, 2018.

Enclose this part with your contest entry

Cut Here

Attach this part to the back of entry

Helpful Hints for Preparing Your Duck Stamp Art Design

Scoring criteria for contest.
“Entries will be judged on the basis of anatomical accuracy, artistic composition and suitability for reduction in the production of a stamp. For 2018, entries will also be judged on how well they illustrate the theme of “celebrating our waterfowl hunting heritage.”

Use bright, bold, pleasing, warm colors.

Make your species is the **dominant main focus** of your entry.

Make sure the habitat is appropriate for the species and its plumage.

Keep the design simple.

Remember, this art is going to be used to produce a stamp — look at your finished product at a reduced size so that you will see what the judges see when they are making a final decision.

Leave room around the outside edges of the design for required stamp language and the denomination.

Finally, remember that the first impression a judge has of your entry is a lasting one.

Good Luck!

*Put your Stamp on
Conservation...
Buy Duck Stamps.*

Checklist

Don't forget to:

- Affix the Entry Form to the back of your entry
- Sign the Display, Participation & Reproduction Rights Agreement
- Include your \$125 entry fee (cashier's check, certified check or money order - NO PERSONAL CHECKS ACCEPTED)

