

**U.S. DEPARTMENT OF ENERGY - BONNEVILLE POWER ADMINISTRATION (BPA)
APPLICATION FOR PROPOSED USE OF BPA RIGHT-OF-WAY**

1-800-282-3713

Ask for Real Property Services or a contact person from web site. www.bpa.gov/goto/LandsCommunity	Date: _____
---	--------------------

Privacy Act Statement
Authority: 16 U.S.C. 832a(c) 16 U.S.C. ch. 12B, 2006
Purpose: BPA will use this information to assess whether your proposed use of our right-of-way will interfere with BPA's land rights.
Routine Uses: This information is authorized to be maintained in Privacy Act system of records DOE-24, "Land Records System." Other routine uses for which this information may be disclosed are listed in the Privacy Act system of records notice for DOE-24, which is published in the Federal Register.
Disclosure: Voluntary; however, failure to provide complete information may result in a delay or denial of your application.

Applicant is required to complete all of page 1. If not submitting an attached map, plan or sketch, page 2 is required.

Checks will not be accepted. Remit payment to BPA electronically. To make payment using Google Chrome, Firefox, or Edge browser, navigate to <https://www.bpa.gov/goto/HowtoPay>; select the blue hyperlink MAKE PAYMENT NOW; select the blue CONTINUE TO FORM button; under Purpose of Payment select REALTY APPLICATION FEE and fill out remaining fields with an *; select CONTINUE to submit payment. Please make sure to select the appropriate box below before making your payment. You should receive a confirmation when finished.

<input type="checkbox"/> NO APPLICATION FEE For individual landowners requesting personal use of BPA Right-of-Way	<input type="checkbox"/> \$250 APPLICATION FEE For developments or subdivisions. Application fee is non-refundable.	<input type="checkbox"/> \$2500 APPLICATION FEE For longitudinal occupancies that require multiple miles of BPA Right-of-Way. Application fee is non-refundable.
---	---	--

Applicant	Owner <i>(Complete only if the applicant is not the owner.)</i>
1. NAME	4. NAME
2. ADDRESS, CITY, STATE, ZIP	5. ADDRESS, CITY, STATE, ZIP
3. TELEPHONE NO. EMAIL ADDRESS: FAX NO:	6. TELEPHONE NO. EMAIL ADDRESS: FAX NO:

7. LOCATION OF PROPERTY (Legal description of the property. *This information is on your title, insurance policy, courthouse deed, or your tax statement.*)
(PROVIDE A COUNTY ASSESSOR'S MAP SHOWING THE OWNER'S BOUNDARY LINES AND THE LOCATION OF USE.)

--	--	--	--	--	--

QUARTER SECTION(S)	SECTION(S)	TOWNSHIP	RANGE	COUNTY	STATE
--------------------	------------	----------	-------	--------	-------

8. PURPOSE FOR WHICH BPA RIGHT-OF-WAY/PROPERTY IS TO BE USED. Check all boxes that apply and complete the information on the following page. *(Include a map, plan or sketch if appropriate.)* NOTE: For submission of digital plans please provide a PDF version. BPA will request larger plans, if needed.

<input type="checkbox"/> Driveway / Roadway Width Width _____ Material _____ PLEASE ATTACH EXISTING AND PROPOSED GRADING PLANS.	<input type="checkbox"/> Pipelines Type: <input type="checkbox"/> Gas <input type="checkbox"/> Sewer <input type="checkbox"/> Water Diameter _____ Material _____ Buried Depth _____	<input type="checkbox"/> Electric Service Line Voltage _____ Underground _____ Overhead _____
--	---	---

Other Uses: _____

Narrative: Please describe your intended use in detail. In order to assure safe clearance, please describe any equipment that will be used for applied use *(including equipment intended to construct and maintain the use)*. Space is provided on page 2 for a drawing. **IF GRADING, PLEASE ATTACH EXISTING AND PROPOSED GRADING PLANS**

9. APPLICANT NAME	10. APPLICANT SIGNATURE	11. APPLICANT TITLE
-------------------	-------------------------	---------------------

IF APPLICABLE, ATTACH NAME, COMPANY ADDRESS, AND A CONTACT PERSON FOR ALL UTILITIES INVOLVED IN PROJECT.

12. RIGHT-OF-WAY Draw in space provided below the location of the proposed use. (**Identify structures and show distances and angles from BPA structures**). Diamonds on the line represent BPA structures on the right-of-way. Copy the series of letters and numbers from the lower half of each BPA structure (see *example below*) and enter in "BPA Structure Identification" block. Indicate which direction is "North" in relation to the right-of-way.

BIG E – CHEM 1-81-2

BPA STRUCTURE IDENTIFICATION



PS2 1-2-A

BPA STRUCTURE IDENTIFICATION



Identify structures and show distances and angles from BPA structures

A large grid area for drawing the right-of-way and identifying structures. A horizontal line is drawn across the middle of the grid, with two diamond shapes representing BPA structures on the line. The grid is 20 units wide and 20 units high.

BPA STRUCTURE IDENTIFICATION

BPA STRUCTURE IDENTIFICATION

U.S. DEPARTMENT OF ENERGY - BONNEVILLE POWER ADMINISTRATION (BPA) APPLICATION FOR PROPOSED USE OF BPA RIGHT-OF-WAY

APPLICANT NAME _____

Complete **ONLY** if overhead or underground foreign line crosses an overhead BPA line. If the foreign line crosses more than one BPA line use additional sheets.

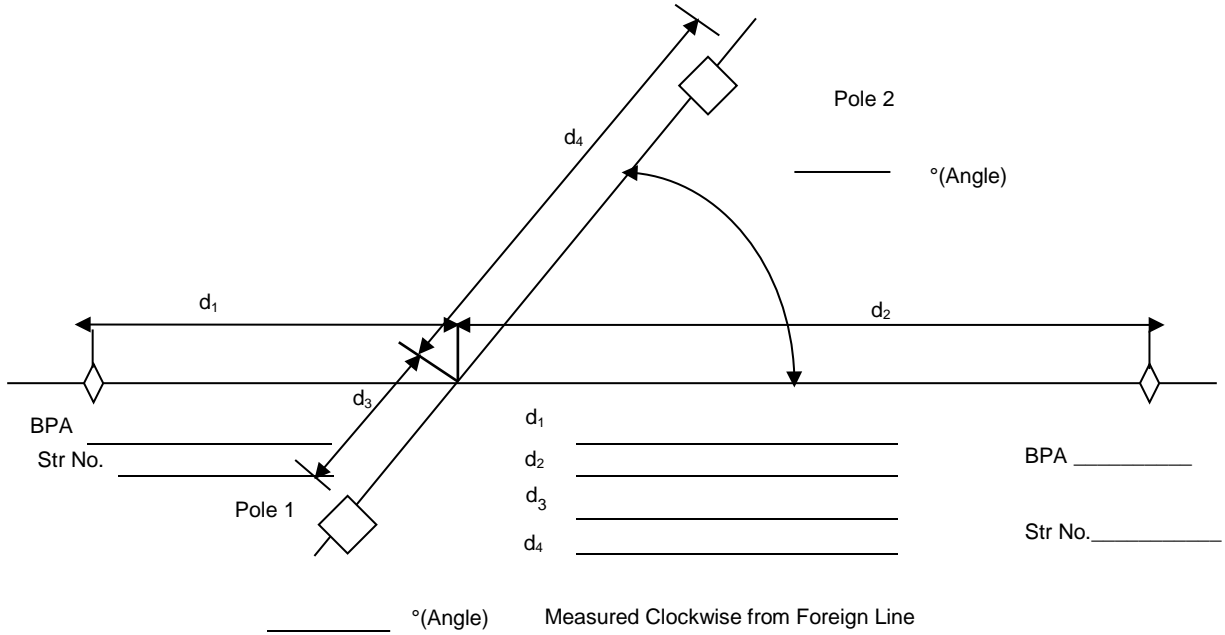

PLAN

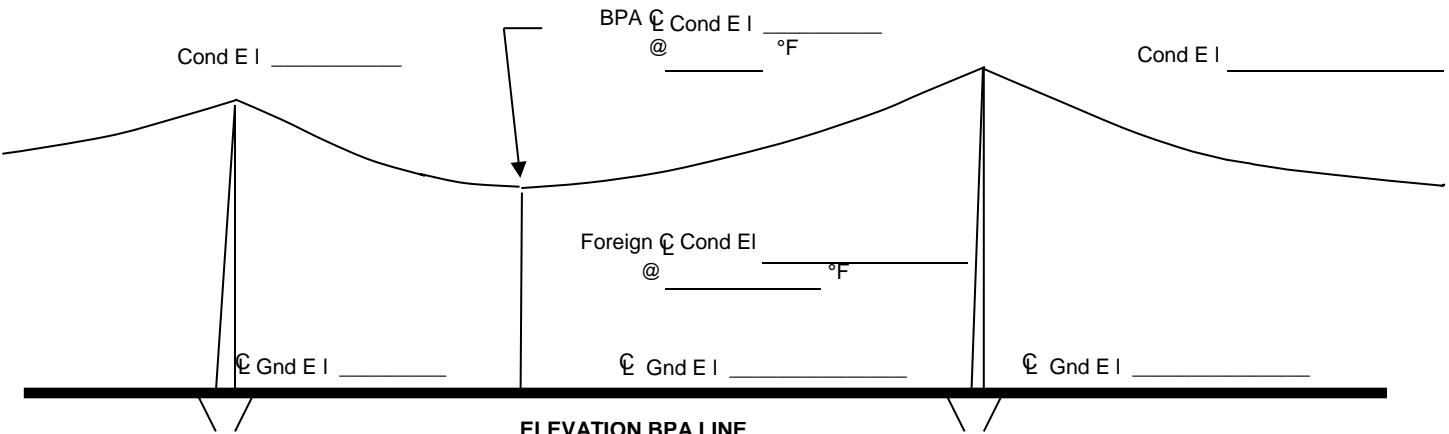

POLES	LENGTH	DEPTH SET	CLASS POLE
POLE 1			
POLE 2			
F I X T U R E S	SIZE OF CROSSARMS		
	MAKE AND CATALOG NUMBER OF INSULATORS		
C O N D U C T O R S	NUMBER	SIZE	
	KIND	VOLTAGE	
	MWT	LOADING	
	COMMENTS		

POLE 1

POLE 2

CONFIGURATIONS

A
P
P
L
I
C
A
N
T

APPLICATION FOR PROPOSED USE OF BPA RIGHT-OF-WAY

Mail your application to the location nearest to your project:

WESTERN WASHINGTON

Location and Address

Phone Number

Snohomish District Office, 914 Ave D, Snohomish, WA 98290

360.563.3640

Covington District Office, PO Box 3621, Portland, OR 97208-3621

253.638.3741

Olympia District Office, 5240 Trosper St SW, Olympia, WA 98512

360.570.4352, 360.570.4333 OR 360.570.4332

Ross Maint. Hdqt. Office, PO Box 3621, Portland, OR 97208-3621

800.836.6691

OREGON

Location and Address

Phone Number

Redmond District Office, 3655 SW Highland Ave., Redmond, OR 97756

541.516.3200

Eugene District Office, 86000 Hwy 99S, Eugene, OR 97405

541.988.7432

Salem District Office, 2715 Tepper Lane, Keizer, OR 97303

503.304.5900

Portland Office, PO Box 3621, Portland, OR 97208-3621

800.836.6619

Hood River, (see Portland for mailing address)

North Bend Area, (see Portland for mailing address)

EASTERN WASHINGTON, IDAHO AND MONTANA

Location and Address

Phone Number

Idaho Falls District Office, (see Tri-Cities Pasco, WA mailing address)

509.544.4747

Tri-Cities District Office, (OR Side), 2211 North Commercial Avenue, Pasco, WA 99301

509.544.4747

Tri-Cities (WA side), 2211 North Commercial Avenue, Pasco, WA 99301

503.230.5510

Spokane District Office, 2410 E. Hawthorne Rd., Mead, WA 99021-9594

509.468.3081

Grand Coulee Area, PO Box 24, Grand Coulee, WA 99133

509.378.7447

Ellensburg Area, PO Box 3621, Portland, OR 97208-3621

503.230.5611

Kalispell Maintenance District Office, 2520 US Hwy 2 East, Kalispell, MT 59901

406.751.7824

Paperwork Reduction Act Burden Disclosure Statement:

This data is being collected to complete an application for proposed use of BPA right-of-way to assess whether it will interfere with BPA's land rights. The information you provide will be used by realty and finance personnel to make a determination regarding the use BPA's right-of-way as per your request. Public reporting burden for this collection of information is estimated to average 1 hour per response, including the time for reviewing instructions, searching existing data sources, gathering and maintaining that data needed, and completing and reviewing the collection of information. Send comments regarding this burden estimate or any other aspect of this collection of information, including suggestions for reducing this burden, to Office of the Chief Information Officer, Enterprise Policy Development & Implementation Office, IM-22, Paperwork Reduction Project this is a new collection and currently does not have an assigned OMB control number. U.S. Department of Energy, 1000 Independence Ave SW, Washington, DC, 20585-1290; and to the Office of Management and Budget (OMB), OIRA, Paperwork Reduction Project (OMB control number:XXXXXX), Washington, DC 20503.

Notwithstanding any other provision of the law, no person is required to respond to, nor shall any person be subject to a penalty for failure to comply with a collection of information subject to the requirements of the Paperwork Reduction Act unless that collection of information displays a currently valid OMB control number.

The Paperwork Reduction Act (PRA) of 1995 requires each Federal agency to seek and obtain approval from the Office of Management and Budget (OMB) before undertaking a collection of information directed to 10 or more persons of the general public, including persons involved in or supporting the operations of Government-owned, contractor-operated facilities.

Submission of this information is voluntary.