Preface

Purpose and Organization

This operating manual describes the approved procedures and methodology to be used by the state offices in production of a high quality database. This state product is commonly referred to as the QCEW file. It has several uses. The Employment and Training Administration (ETA) uses the QCEW file for oversight of state unemployment insurance (UI) programs. State governments use it for many internal purposes such as revenue forecasting. The QCEW file is the main component of the personal income portion of the national and regional income and products accounts, better known as the GDP program. It is used to benchmark national and state current employment estimates produced by the BLS CES program. States and BLS use it to publish detailed industry statistics on the local and national economy. The QCEW file is also used as the sample frame for many programs.

This manual documents the responsibilities and operations of the QCEW program. It begins with an overview and background material, then proceeds through additional chapters of state and BLS operations. The sequence of chapters is, in a general sense, chronological. Several early chapters cover basic concepts such as assigning classification codes and handling multiple-worksite employers. These are followed by a chapter on the Annual Refiling Survey. The remaining chapters work through the quarterly sequence of loading, editing, and transmitting the data via the Enhanced Quarterly Unemployment Insurance [EQUI] file, including such items as the national office processing and the national office/state coordination. Following the chapters are appendices providing technical information such as file layouts, data element definitions, edit conditions, imputation formulas, due dates, and a recommended processing schedule.

Deliverable percentages, methodology, calendars, and policy information are periodically updated in this Manual. Announcements and instruction are also accompanied by numbered QCEW Program Technical Memoranda – some intended only for regional office staff but more frequently for joint action by state, regional, and national office staff members. The manual updates may require the replacement of chapters, or chapter sections or appendices. The most updated version of the Manual will be made available as an online document. Its web location as part of the Bureau's StateWeb resource archive should be referenced often.

Submitting Your Comments

BLS welcomes suggestions from state staff on improving this manual, as well as suggestions for improving the QCEW program. Please provide any comments to your regional office. Regional offices may submit comments to the national office via E-mail to the group name **QCEW_MANUAL_TEAM@bls.gov**. All comments will be read and evaluated.

Confidentiality

BLS considers maintaining the highest degree of confidentiality on the data collected to be critical to the program's integrity and its ability to successfully solicit employers to report for its statistical programs. Because of this, BLS has developed rules to strenuously protect that confidentiality. States are an integral part of the Federal-State data collection system and, as cooperating agents, must comply with BLS regulations on confidentiality to guard the trust that has been developed with respondents over years of operating statistical programs.

States are required to adhere to the BLS confidentiality requirements as stated in the Labor Market Information (LMI) Cooperative Agreement.

The Confidential Information Protection and Statistical Efficiency Act (CIPSEA) of 2002 (Title 5 of Public Law 107-347) safeguards the confidentiality of individually identifiable information acquired for exclusively statistical purposes under a pledge of confidentiality by controlling access to and uses of such information. In some cases, CIPSEA has a significant impact on the state's ability to share data with other users. A copy of the CIPSEA law can be found on the State Intranet (StateWeb) at <http://199.221.111.170/security/CIPSEA%20Title%20V.doc>

CIPSEA precludes the release by BLS and the Bureau of Economic Analysis (BEA) to other agencies or to the public of any employer reported data for individual reporting units without the specific written authorization of the State Workforce Agency. Blanket authorization for this type of data sharing can be granted to BLS via the LMI Cooperative Agreement by checking the appropriate boxes in section F (Data Sharing Blanket Approval) of the QCEW program work statement.

General guidelines for the sharing of data under CIPSEA include the following:

- Data collected by UI and the State Workforce Agencies for the QCEW are sharable for statistical and UI administrative purposes.
- In the case where data collected by the states for other BLS programs that pledge confidentiality [Current Employment Statistics (CES), Occupational Employment Statistics (OES) and Occupational Safety and Health Statistics (OSHS)] are used in the QCEW, these data are **not** sharable without intervention to remove the confidential portion. State QCEW systems have programs that allow the creation of CIPSEA compliant files.
- Data may be shared fully between governmental agents who have sworn to protect the confidentiality of data under CIPSEA. These include all BLS and state staff participating in BLS programs or using BLS confidential data. As a result, states and BLS may freely share QCEW data with each other on an as-needed basis.

Other laws that affect the release of QCEW data include:

- The Social Security Act
- Chapter 23 of the Internal Revenue Code of 1986 (the Federal Unemployment Tax Act)
- The Wagner-Peyser Act
- Other regulations issued by the Employment and Training Administration (ETA) and/or the Secretary of Labor

The regulations cited above are applicable to data collected by the state on the state's quarterly contribution reports or initial status determination forms for inclusion in the QCEW Program.

Information collected for the QCEW Program on U.S. Office of Management and Budget (OMB) approved forms (such as the Industry Classification Form, Industry Verification Form, and the Multiple Worksite Report) are governed by the BLS Commissioner's Order No. 1-06 (Commissioner's Order on Confidentiality), which requires BLS to hold these data in confidence to the full extent permitted by Federal law. The informed consent language on the individual forms indicates that the states will use the information for Unemployment Insurance program purposes, statistical purposes, and other purposes permitted by state law.

Public disclosure of QCEW data is limited in some cases, in order to protect the identity and economic information of employers that provide data under a pledge or expectation of statistical confidentiality.

Higher-level aggregates can include the non-disclosable data suppressed at the detailed levels. However, disclosure limitation techniques have been applied to limit the extent to which these totals could be used to reveal the data for individual employers.

Information regarding employment and wages of UCFE-covered Federal employees is deemed to be fully disclosable under provisions of the Freedom of Information Act.

StateWeb <http://199.221.111.170/> has a section on Confidentiality and Security that provides a convenient source of information on BLS rules, including determinations on handling data based on CIPSEA.

Authorization

COLLECTION APPROVED BY O.M.B.: O.M.B., 1220-0012
O.M.B. APPROVAL EXPIRES: FEBRUARY 28, 2021.

Reports from the "Employment, Wages, and Contributions program" (also known as the "QCEW program") are authorized by 42 U.S.C. 503, and 20 CFR 609. Reporting is required to obtain or retain funding by BLS.

In addition, the Annual Refiling Survey is an integral part of the QCEW program in which employers are generally surveyed over a three-year cycle. This survey is authorized under 29 U.S.C. 2.

Comments regarding the burden estimates or any other aspect of the QCEW Program or its Annual Refiling Survey, including suggestions for reducing the burden, should be sent to the Bureau of Labor Statistics, Division of Administrative Statistics and Labor Turnover, Room 4860, 2 Massachusetts Ave., NE, Washington, DC 20212 and to the Office of Management and Budget, Paperwork Reduction Project, Washington, DC 20503.

Chapter 1 – Overview of the QCEW Program

The Quarterly Census of Employment and Wages (QCEW) Program, formerly referred to as the ES-202 program, is a cooperative program involving the State Workforce Agencies (SWAs) and the Bureau of Labor Statistics (BLS) of the U.S. Department of Labor. The QCEW program collects employment and wage information for workers covered by State Unemployment Insurance (UI) laws and for Federal workers covered by the Unemployment Compensation for Federal Employees (UCFE) program. Data collected under the QCEW program serve as a sampling frame for BLS establishment surveys and as an input to other Federal and State programs, thereby playing a central role in monitoring the nation's economy. The data are gathered through the cooperation of various offices within the SWAs and BLS.

The program began with the Social Security Act of 1935 and evolved into a cornerstone of modern labor market information. The process of data collection occurs on a quarterly basis through the production of the Enhanced Quarterly Unemployment Insurance (EQUI) file and on an annual basis through the Annual Refiling Survey (ARS). States produce the data and send it to BLS using a standardized State processing system. Common terminology is used for clear and consistent communication and reporting of data throughout the program.

----- Contents of Chapter 1 -----

- 1.1 The Program and Its Data
 - 1.1.1 Data Sources
 - 1.1.2 Data Transmission via the EQUI
- 1.2 Purpose and Uses of the Data
- 1.3 History of the QCEW Program
- 1.4 Responsibilities of the Participants
- 1.5 Overview of Quarterly and Annual Processing
 - 1.5.1 Main Processing Flow
- 1.6 Using Standardized Processing Systems
- 1.7 Definitions - Basic Terms
- 1.8 Coverage of the QCEW Program

1.1 The Program and Its Data

The Quarterly Census of Employment and Wages (QCEW) Program, formerly referred to as the ES-202 program, is a Federal/State cooperative program between the State Workforce Agencies (SWAs) and the Bureau of Labor Statistics (BLS). The QCEW program collects employment and wage information for workers covered by State unemployment insurance (UI) laws and for Federal workers covered by the Unemployment Compensation for Federal Employees (UCFE) program.

Jobs that are exempt or otherwise not covered by unemployment insurance are not included. In the private sector, this includes certain wage and salary agricultural employees, self-employed farmers, self-employed nonagricultural workers, domestic workers, and unpaid family workers. Workers covered by the railroad unemployment insurance system and members of the Armed Forces, including those stationed in the United States, and are also excluded. Certain types of nonprofit employers, such as religious organizations, are given a choice of coverage or exclusion in a number of States, so data for their employees are reported to a limited degree. Some students and spouses of students in the employ of schools, colleges, and universities are also excluded. Program coverage is detailed later in this manual.

New employers provide information about their owners, location(s), addresses, activities using Initial Status Forms and other means. Ongoing employers report wage and employment data via the Quarterly Contributions Report (QCR) or the Multiple Worksite Report (MWR). The MWR distributes UI account level information to the worksite level. This itemized profile of an account provides specific geographic and economic activity designations for each business establishment a company may have at various locations across a State. MWR solicitation and collection options provide a means for large employers with multiple locations to streamline the reporting of their employment and wage data. The Report of Federal Employment and Wages (RFEW) and MWR data are collected centrally for some reporters.

The QCEW program produces a collection of highly detailed, accurate, and comprehensive employment and wage totals for every county in the United States, Puerto Rico, and the Virgin Islands. These main data categories are combined with address and code information assigned during a business' Initial Registration with the Tax Department and later validated or updated based on response to the Annual Refiling Survey (ARS). State QCEW staff are tasked with collecting, compiling, reviewing, researching, and explaining the data using the State standard system and methodologies outlined in this manual.

The combined information is transmitted quarterly to the Bureau of Labor Statistics in Washington, DC, on the Enhanced Quarterly Unemployment Insurance (EQUI) file. The national office processes, and with Regional Offices, edits the State-supplied data. After a rigorous review cycle, BLS publishes this multi-faceted database according to a well-publicized schedule to a wide variety of users. A number of States choose to publish data after the conclusion of BLS review. The State agencies work in cooperation with the BLS to gather data and publish information derived from those data. A common set of micro data are used for State

and national purposes. These programs are funded through annual Cooperative Agreements between the States and BLS.

The resultant micro data cover over ten million business establishments and provide a virtual census of payroll employment. These micro data are aggregated to the macro level, screened for confidentiality, and made available to the public. The resultant macro data series [Industry-County-Ownership combination] comprise the most complete universe of monthly employment and quarterly wage information published. The data are also made available to other statistical agencies, programs within the BLS, and academic researchers and are used as a sampling frame for BLS surveys and linked longitudinally for labor market research. The successful cooperation between States and the Bureau of Labor Statistics results in high-quality data that have widespread applications.

At the macro level, the data are aggregated by industry, ownership, and county to produce a comprehensive set of employment and wage totals for every county in the United States, Puerto Rico, and the Virgin Islands. This macro data are then summed further to produce totals by metropolitan area, State, and the nation as a whole at every level of industrial detail. The resulting data are a strict hierarchical structure of over three million macro cells giving detailed, accurate, and comprehensive macro data for every covered sector of the US economy.

The strength of the QCEW macro level data is its comprehensiveness, which results in more accurate data and substantial industry and geographic detail. The data series produced are the most complete universe of monthly employment and quarterly wage information available by industry, ownership, county, and State. A limitation of QCEW data is that the QCEW data are not as timely as other similar data series such as the Current Employment Statistics (CES) data, which is a monthly survey of a smaller number of reporters.

1.1.1 Data Sources

New employers register their business with the State UI tax unit via Initial Status Forms, websites, and other means. This registration provides basic business identification and classification information to establish a UI account. UI tax administration, the Quarterly Contribution Reports (QCRs), and the Initial Status Forms are all under the oversight of the Employment and Training Administration (ETA). The QCRs and the Initial Status Forms are State-specific; neither are standardized across States. UI tax departments generally handle follow-up with employers for delinquent and missing data for these two forms.

The MWRs provide monthly employment, quarterly wages, and UI tax information. Unlike the QCR, the MWRs break out the reported data by worksite. The cooperative program obtains information on the location and industrial activity of each reported establishment and then assigns location and industrial classification codes accordingly. This establishment level information is aggregated by industry code to the county and higher aggregation levels.

Some employers with more than one worksite also file Multiple Worksite Reports with the QCEW unit of each State in which they have multiple worksites. For some employers, this requires filing QCRs to UI tax departments in various States as well as filing MWR reports to QCEW units in those same States. To minimize this burden, BLS has provided some of these reporters with the means to report all of their MWR data to one central location at the Electronic Data Interchange Center (EDIC). Such reporters include employers operating numerous worksites in several States, large government agencies, and service bureaus who handle payroll functions for many different firms.

The Electronic Data Interchange Center, also known as the EDI Center or EDIC, is located in Chicago, Illinois. Employers who submit their data to the EDI Center are considered central reporters. In addition to MWR data, the EDI Center receives files of Report of Federal Employment and Wage (RFEW) data for some Federal government reporters including the Department of Defense (DOD) and the United States Postal Service. (See Chapter 4.) Most EDI data are submitted in a standard ASCII format that was developed in coordination with the CES program. The EDI Center handles central reporting for both the QCEW and CES programs and solicits potential central reporters for both programs. Once processing for a company's quarterly data is finished, the EDI Center distributes the data electronically to the States. The complexity of operations required by the EDI Center is justified by the substantial savings in time and money these operations provide to the SWAs.

A separate but related activity is the ARS. This survey is used to verify or update industry, geographic, and ownership codes; collect physical location and mailing addresses; and identify new multi-unit employers. The ARS interfaces with the regular QCEW program quarterly processing at two points:

1. The units selected for the survey are drawn from the first quarter EQUI deliverable file and based on BLS selection criteria.
2. The results of the survey are incorporated back into the State's micro database for processing with first-quarter data the following summer. This information results in MWR breakouts, code changes, and address enhancements.

1.1.2 Data Transmission via the EQUI

Approximately four months after the end of the reference quarter, States produce their key QCEW deliverable for BLS -- the EQUI file. This file contains all business establishment records for the applicable reference quarter plus update transactions for prior quarters. EQUI records include the following information:

- UI Account Number
- Reporting Unit Number
- Employer Identification Number (EIN)
- Trade Name

- Legal Name
- Reporting Unit Description
- Addresses (up to three)
- Telephone Number, Fax Number and Email Address
- Monthly Employment
- Quarterly Wages
- Classification Codes - Industry, County/Township, and Ownership
- Geocoding Information
- State Analyst Comments
- Predecessor/Successor Information
- Numerous other data elements that serve a variety of program purposes.

States submit their EQUI file to the national office. Three transmittal methods are possible depending on the standardized State system being used. (See Section 12.3.) For States not at the service center, EUS Web and File Transfer Protocol (FTP) are acceptable. The states complete and submit transmittal forms via email that give notice of the data submittal and include certain pieces of information necessary to facilitate Division of Business Establishment Systems (DBES) processing. As the EQUI data are received, DBES aggregates the data and provides it to Bureau of Economic Analysis (BEA) for their data uses.

Each EQUI file is processed through the national office edit system, which produces a set of reports. Some are error reports requiring further review, and some are reports counting, tabulating, and listing the data in various ways for production review and quality control purposes.

Reviewing the Edit Outputs

The Division of Administrative Statistics and Labor Turnover (DASLT), Division of Business Establishment Systems (DBES), and the regional offices all play roles in reviewing the BLS edit outputs and identifying potential problems in the data, and work with the States to perform data clean up in response to the BLS edits. States address the most critical errors first and use the guidance and/or priorities provided by the regional offices. States further research the data, make necessary corrections to the micro level records, and provide standard comment codes to explain unusual data.

Submitting EQUI Update Transactions

States can submit update transactions in response to the BLS edits and include any new or corrected data to the initial EQUI file through a Subset file. States can also make their update transactions in their State system and provide these transactions to the regional offices in the State's responses to regional and/or national office questions. The national or regional office then updates these corrections on the BLS national database. These BLS corrections often render Subsets unnecessary. However, States must submit a Subset if requested by the national or regional office; otherwise it is at the State's discretion whether or not to submit a Subset file.

As with the full EQUI file, three transmittal methods are possible for the Subset file. (See Section 12.3.)

DBES processes the EQUI updates from the States. Another set of reports is produced reflecting the updated data. As earlier in the cycle, DASLT, DBES and the regional offices all play roles in reviewing the BLS edit outputs and identifying any remaining problems in the data. Once the regional office is satisfied with the data, they provide a “clean” notice to the national office roughly 26 to 30 days after the national office receives the official EQUI file. This is, in actuality, an interim designation that must be reconfirmed in the future quarters since update transactions often occur concurrently with the data submittals for future quarters.

Because of the scope of the Social Security legislation and the UI system, the QCEW program has comprehensive data on almost every business establishment in the United States. The joint effort between cooperating States and BLS ensures that the data are collected, edited, processed and released in a manner that is timely and guarantees quality. Over the course of its history, the QCEW program has evolved from producing a quarterly report of employment and wage data at the State level to serving as one of the cornerstones of modern labor market information for the nation.

1.2 Purpose and Uses of the Data

The QCEW data are collected for statistical purposes and are used widely within the Bureau of Labor Statistics, other government agencies, academic and research circles, and the public at large.

The Longitudinal Database

One of the chief vehicles for using QCEW micro data is the Longitudinal Database (LDB) which is the Bureau's central business establishment database. Numerous BLS surveys draw their sampling frames from the LDB. A critical part of the LDB is the linking of establishment records from quarter to quarter. While most establishments maintain the same identifying information over time, establishments that are sold from one owner to another typically experience a change to their primary identifier; such establishments can appear to be a business death and birth rather than being continuous over time. LDB processing is intended to link continuous establishments over time, regardless of any transfer of ownership. Once the data are linked, the Division of Business Establishment Systems (DBES) makes the updated business establishment list available for sampling by other Bureau programs. Surveys that draw their sampling frames from the LDB include the Producer Price Index (PPI), Occupational Employment Statistics (OES), Current Employment Statistics (CES), Occupational Safety and Health (OSH), National Compensation Survey (NCS), and Job Opening and Labor Turnover Survey (JOLTS).

In addition to its role as the Bureau's business establishment sampling database, the LDB is of great interest to labor market researchers. Longitudinally linked data can produce accurate and

extensive statistics on business births and deaths for job creation and job destruction analysis. A set of standard tables and statistical output is produced each quarter to show these changes within the economy as a whole.

Broad Statistical Use

The QCEW data have broad significance in evaluating labor trends and major industry developments and are used in time series analyses, industry comparisons, and special studies such as analyses of wages by size of establishment. The QCEW program outputs are instrumental in determining Federal allocations of program grants to State and local governments and they also serve as the basic source of benchmark information for employment by industry and employment by size of establishment in the Current Employment Statistics (CES) program, the Occupational Employment Statistics (OES) program, and the Occupational Safety and Health (OSH) Statistics program. The Bureau of Economic Analysis (BEA) of the Department of Commerce uses QCEW data as a base for estimating a large part of the wage and salary component of personal income accounts, Gross Domestic Product (GDP), and Gross Domestic Income (GDI). The Social Security Administration and State governments also use QCEW data in updating economic assumptions and forecasting trends in their taxable wage base. Business and public and private research organizations find the QCEW program one of the best sources available of detailed employment and wage statistics.

The QCEW program produces data necessary to both the Employment and Training Administration (ETA) and the various State Workforce Agencies (SWA) in administering the employment security program. The data accurately reflect the extent of coverage of the State unemployment laws and are used to measure:

- UI revenues
- National, State, and local area employment
- Total and taxable wage trends

In addition to its usefulness as a measuring device, the information is used in the following ways:

- Actuarial studies
- Determining experience ratings
- Determining maximum benefit levels
- Determining areas needing Federal assistance
- Determining the solvency of unemployment insurance funds

For specific examples of who uses the QCEW data and for what purpose, refer to the following table.

Data Users	Data Uses
Bureau of Economic Analysis	Personal Income (National Income and Product Accounts) County Personal and Per Capita Income Gross Domestic Product (GDP) Gross Domestic Income (GDI)

Data Users	Data Uses
Bureau of the Census	Industry Coding Sampling
Employment and Training Administration	Actuarial and Trust Fund Analysis Insured Unemployment Rate Extended Benefit Trigger
BLS Directly Collected Surveys	Producer Price Index Sampling NCS Sampling
Occupational Safety and Health Statistics Program	Sampling and Benchmarking
Office of Employment and Unemployment Statistics (OEUS) Programs	CES Benchmarking and Estimation Research Local Area Unemployment Statistics (LAUS) Program's Small Area Employment Estimates OES Sampling and Benchmarking JOLTS Sampling and Benchmarking
QCEW Program Office (DASLT)	Publication and Press Releases Birth/Death and Gross Flow Studies Other Longitudinal Analysis
SWA Research Units (Non-OEUS Programs)	Wage Survey Sampling Birth/Death Studies
SWA Employment Security Units	Job Service Sampling for Audits
SWA UI Unit	Computation of General UI Tax Rates Setting UI Tax Rates for New Employers by Industry Determination of Maximum Weekly Benefit Amounts
Other State Government	Revenue Department Budget Modeling Regulatory Use (e.g., Survey Employers by industry) Measuring Demand for Transportation
Local Economic Planners	Forecasting Demand for Schools, Roads, etc.
Private Sector Planning	Economic Forecasting by Banks Utilities Measuring Demand by Industry Insurance Companies Setting Rates by Industry
Private Consultants	Econometric Modeling and Forecasting
Academics	Assorted Research
Media	Articles and Publications
General Public	Miscellaneous

Publication of Data

Data from the QCEW program are regularly used to publish reports and issue press releases, such as the following examples:

1. *Employment and Wages Annual Averages*: This annual bulletin is a comprehensive book of QCEW macro data published 10 to 12 months after the close of the fourth quarter in the reference year.
2. *County Employment and Wages*: This publication provides a quarterly count of employment and wages reported by employers covering more than 95 percent of U.S. jobs, available at the county, MSA, State and national levels by industry.
3. *Business Employment Dynamics*: This publication and quarterly data series consist of gross job gains and gross job losses statistics from 1992 forward. These data help to provide a picture of the dynamic State of the labor market.
4. *Public Release Files*: This macro data are available to the public on the web at LABSTAT, the Bureau's public-access site. These data are essentially the full set of data from which the news releases are extracted. As such, the public release files are typically available shortly after the corresponding annual or quarterly press releases. The annual data includes establishments, employment, total wages, average pay, and average weekly wage. The quarterly data includes establishments, total wages, average weekly wage, and average monthly employment. Data are available at the county, metropolitan area, State, and national levels at full NAICS industry detail.
5. *Other Releases*: In addition, BLS releases data through Monthly Labor Review (MLR) articles The Editor Desk (TED), Spotlight on Statistics, social media and other means. The cooperating SWAs also issue quarterly and/or annual reports of QCEW data. States are required to publish QCEW data under the Labor Market Information (LMI) cooperative agreement. These reports are issued in various formats.

To maintain the confidentiality of respondents, BLS withholds publication of UI-covered employment and wage data that does not meet BLS disclosure criteria. (Note that federal government data are not confidential.)

Since macro totals are hierarchically structured, totals for an entire State are the sum of each county within the State. Likewise, totals at the national level are a sum of the State totals. If lower-level totals are suppressed for confidentiality purposes, the upper-level totals are only released if they do not reveal the suppressed data.

1.3 History of the QCEW Program

Beginnings

The QCEW program began as a result of the Social Security Act of 1935, which among other things, authorized collection of information to determine if State unemployment compensation programs were in compliance with the act. Unemployment insurance was instituted to provide temporary financial assistance to unemployed persons.

From the inception of the national UI system in 1938, when the Federal Unemployment Tax Act (FUTA) became effective, until 1972, collection of the data, publication, and technical expertise were the responsibilities of the U.S. Department of Labor's Manpower Administration or its predecessor agencies. In 1972, technical responsibility was transferred to BLS.

Deliverables

In 1980, the QCEW program deliverables consisted of a macro-level report with data classified by 4-digit Standard Industrial Classification (SIC) code by ownership at the Statewide level. This report, due the last day of the fifth month following the end of each quarter, was transmitted to BLS on tape. Within BLS, these macro-level data were subjected to basic edits designed to detect invalid data and list records that failed limited month-to-month employment and/or average wage tests. No inter-quarter edit was performed to check changes in employment and/or wage levels between quarters even though such changes account for most of the questionable records. Inter-quarter changes often reflect changes in employer reporting from the previous to the current quarter, for example, not submitting a quarterly contribution report or statistical supplement, or installing a new payroll system. The States received the edit output from BLS and were required to complete their review and provide corrections within a 60-day clean-up period with regional office assistance.

States also independently provided the Bureau of Economic Analysis (BEA) with a tape of county-level QCEW data by 2-digit industry code 30 days after the ES-202 Report due date. BEA used this data for their Personal Income and Gross National Product estimates. (BEA now emphasizes Gross Domestic Product rather than Gross National Product.) BEA staff manually reviewed the data and contacted the States directly with their questions for specific records. BEA then provided BLS with a copy of these edited county-level employment and wage data to satisfy various metropolitan area and county data requests and to develop a Wage Index for ETA. This index was used to determine the maximum wages that an enrollee in the Comprehensive Employment and Training Act (CETA) Public Service Employment (PSE) program could be paid. BLS, using ETA working funds, compensated BEA for an accelerated review of these county-level data so that the needs of ETA could be met.

An Annual Refiling Survey (ARS), used to verify or update employer industry, area, and ownership codes, was already part of the QCEW program at that time. Most States, however, were not meeting the program goal of conducting the survey for 1/3 of the employer universe each year, nor were many States following the cyclical ARS schedule recommended in the QCEW Operating Manual. At the conclusion of the ARS each year, States were required to submit a Code Change Supplement (CCS). The CCS report at that time was only a summary listing of all the industry and ownership changes that would be effective with the next first-quarter ES-202 Report. This listing was produced at only the Statewide level and was due on July 31 of each year. It consisted of two sections. The first was a "To-From" arrangement that displayed:

1. All of the movement into a 4-digit industry in SIC order
2. The corresponding 4-digit industry code that was the source of the movement and
3. The December employment being transferred.

The second section showed the "From-To" relationship. Determining the net movement within a particular 4-digit industry code required manual computations, and sub-State analysis was impossible.

Also in 1980, States provided a separate tape to BLS containing the names and addresses of employers that were covered by Unemployment Insurance (UI). This was essentially identification information for the micro records whose employment and wages formed the basis of the States' macro data. This Name and Address tape, submitted once a year, was used to update the BLS sampling frame for many of its various establishment surveys. The tape contained data for the first quarter of each year and was due on October 1. All editing review and correction of the micro-level Name and Address file were conducted by Office of Survey Design staff in Washington. States received little or no substantive feedback on the quality of these micro data.

Initiative and Improvement

In 1981, to increase both the geographic and industrial level of detail available, BLS proposed that all States submit one macro-level tape each quarter providing 4-digit SIC detail by county, in lieu of separate tapes showing different levels of detail to BLS (Statewide 4-digit industry code) and BEA (county 2-digit SIC). BLS proposed copying this tape upon receipt and providing it to BEA. This was phased in over a three-year period, with the last States converting with the submittal of data for the fourth quarter of 1983.

In 1982, BLS began producing and providing multi-quarter listings to assist regional office staff and States in their review of these employment and wage data. This was the first formal review of employment and wage changes between quarters. The listing presented Statewide data by 4-digit SIC and ownership for six quarters. It was developed as an interim measure until an inter-quarter edit could be designed and implemented.

In 1983, an inter-quarter edit was implemented to further assist States and BLS staff in identifying questionable data, but only at the Statewide level. This was another interim measure until a full-scale county-level macro edit could be tested, documented, and installed.

During this same period, the funds that ETA had been providing to BLS were reduced as the CETA PSE program was phased out. This reduction of the BEA role in the county-level edit and review process created a void which BLS would fill about a year later.

In 1983, the Office of Employment and Unemployment Statistics assumed program office responsibility for the BLS Universe Maintenance System (UMS) from the Office of Survey Design. The UMS was the computer system housing the sampling frame used to conduct most directly collected BLS establishment surveys. As noted earlier, the States had received no feedback on the quality or content of the micro-level UI Name and Address files that were the input to the UMS.

One of the changes that initiated a transition from a macro to a micro emphasis was the redesign of the CCS Report. To meet many different program needs, the summary listing was replaced with a tape that contained all noneconomic code changes at the micro level. Since the new data were submitted at the micro level (including State-specific UI number) and included all identifying code information along with December employment, summaries of net employment changes could be produced at the 4-, 3-, 2-, and 1-digit industry code level of detail for the Nation, State, or metropolitan areas. The Current Employment Statistics (CES) program was able to use the tape to produce summaries of change for each of their basic estimating cells. They could also use these micro-level records to update the industry, county, and ownership codes of their sample members.

The QCEW program used the CCS micro data to verify changes in codes and also to link records placed on the UMS database. At that time, the record key consisted of a combination of the UI account number and the industry, county, and ownership codes. Previously, a change in industry code, for example, created a discontinuity on the UMS by terminating the record with the old code and replacing it with a record with the new code. The micro-based CCS permitted linkage of these records as they were loaded to the UMS, thereby preventing the creation of false births and deaths that would otherwise have resulted from the code changes.

In 1984, BLS introduced the county-level macro edit. This edit provided BLS with the flexibility to adjust the edit tolerances each quarter, if desired. The edit was also exported to the States to provide their staff with the opportunity to review these macro data prior to submittal and update appropriate records or provide comments to BLS to explain unusual data.

Until 1986, management of the QCEW program was the joint responsibility of ETA and BLS. Before 1984, the ETA provided States with operating funds from the UI Trust Fund and had overall financial management responsibilities, whereas BLS had only technical responsibility. During 1984 and 1985, funding responsibility was shared. Beginning in 1986, BLS assumed full responsibility for both the funding and technical aspects of the program.

In 1986, BLS modified an existing State system to create the SIC Refiling Control System (SRCS) software package for States to manage ARS activities. By 1988, all but five States had installed the SRCS, which managed the survey activities related to the 1987 SIC Revision. One output of this software package was the ARS Control File, which included updated code information from each employer that was sent an ARS questionnaire. The control file included information on the following:

1. Whether the employer responded to the ARS
2. Whether the employer indicated that the industry description on the ARS questionnaire accurately described the industrial activity
3. Updates to SIC, county and or ownership codes, plus auxiliary code, if applicable; and
4. Date the industry code was verified or corrected.

SRCS was replaced in 1988 with a newer version, Annual Refiling Control System (ARCS), due to multiple bugs and the upcoming 1987 SIC Revision. This system was mandated by BLS to be installed in all States.

After the 1987 SIC Revision, the control file tape became a new deliverable and was used to supplement the BLS Universe Database (UDB), which replaced the UMS in 1989.

Universe Database (UDB)

In 1987, BLS launched a multi-year project to improve the quality of the data on the UMS and to redesign the database on which these data were stored. States were funded to implement these new requirements over a two-to-three year period. New data elements were added to the Name and Address file, and the frequency of the file was increased from an annual submittal (for first quarter) to a quarterly submittal, beginning in 1989.

BLS also developed the ability to store various types of addresses on the new database. Emphasis was placed on obtaining physical location addresses of establishments. A Reporting Unit Number was also added to each record to uniquely identify it and distinguish between establishments reported under the same UI account number in the same county and industry.

Also in 1987, on the recommendation of the Economic Policy Council (EPC), OMB requested that BLS submit a proposal to become the central agency for the collection of nonagricultural business identification information. The main purpose of the EPC recommendation was to increase both the quality and comparability of national economic statistics by establishing a single, high-quality source of business data that would be available to selected Federal statistical agencies.

To meet this challenge, BLS recognized that the business identification information currently available on employers engaged in multiple operations within a State would have to be improved. The Business Establishment List (BEL) Improvement project was initiated to obtain this multi-establishment employer information on a quarterly basis.

BEL Improvement Project

Under the BEL Improvement Project, collection of employment and wage data for multi-establishment employers was changed from a reporting unit (county/industry total) basis to an individual worksite (establishment) basis. As part of this change, the size criterion used to define multi-establishment employers was lowered to include smaller employers. As a result, the number of establishments and the number of multi-establishment employers increased. The State statistical supplement forms that were previously used to collect multi-establishment employer data were replaced by a standardized form for use in all States.

This project was initiated in late 1988 using the ARS questionnaire. The survey obtained worksite identification information for existing multi-establishment employers and identified multi-establishment employers previously coded as single-unit employers. To capture physical location address information for single unit employers collected from the ARS questionnaire, the SRCS was modified in mid-1988, and the new version was exported to the States.

A new standardized statistical supplement, the Multiple Worksite Report (MWR), received OMB clearance and was mandated for State use beginning with the first quarter of 1991. (While State use was mandatory, the actual reporting on the form by an employer was voluntary in most States and mandatory in others.) The MWR was intended to collect employment and wage information quarterly from multi-establishment employers.

In 1988, as part of the 1987 SIC revision, the 60-day macro data clean-up period was reduced to 30 days to meet the tight timeframe resulting from dual submittal of QCEW program deliverables under the two classification systems. This reduction in the time frame also accomplished another objective: to ensure that States had clean micro data available to submit on the Name and Address files. Prior to this change in timing, the Name and Address file had been due 30 days after the due date for the first quarter macro report. But because the States previously had 60 days to clean-up the macro report, the Name and Address file could have been created from micro data that were not clean. The reduction from 60 to 30 days was a logical step, and assumed that States would make all necessary micro-level changes to their QCEW working files prior to creating the UI Name Address file.

Electronic Data Interchange Center (EDIC)

In February of 1995, the Electronic Data Interchange (EDI) Center opened in Chicago, Illinois. The EDI Center provides companies and installations who have multiple worksites in more than one State with the means to submit their MWR and RFEW data to a central location rather than separately to each State, and to submit data electronically rather than on paper. The EDI Center processes the data submitted and forwards these edited data to the States for inclusion in the States' micro databases and submitted EQUI files.

ES-202 Improvement Project

The Bureau continued with more improvements to the QCEW program and the BEL with the implementation of the ES-202 Improvement Project ("Mic/Mac") in reference year 1997. One of these improvements included replacing the three separate and somewhat redundant deliverables with one deliverable -- the Enhanced Quarterly Unemployment Insurance (EQUI) file. The EQUI incorporated many new data elements, including information from the ARS. A macro file would be generated in the national office from the micro data it contained.

Another major accomplishment of the Mic/Mac project was to convert all States to standardized QCEW processing systems, a key to implementing timely updates to State systems at relatively low costs. These processing systems, developed and maintained by Utah and Maine, ensure that the changes States make to their micro database files are automatically reflected on the EQUI file. Also entailed in the Mic/Mac project were many changes to core processing in the States and BLS, including revamped editing routines to ensure consistent edits between BLS and the States. These systems were also designed to accommodate the conversion to the North America Industrial Classification System (NAICS).

Service Center

September of 1997 saw the establishment of a service center to generate and process data for the States that use EXPO, the largest standardized QCEW State processing system. Not all EXPO states use this facility; however, States that do so no longer need to install updates to the system locally or generate EQUI files locally for shipment to BLS. Both of these functions are accomplished directly at the service center. A Window's based downsized system, WIN-202, is used by 14 States with similar functionality.

Longitudinal Database (LDB)

Implementation of the ES-202 Improvement Project in reference year 1997 necessitated improvements in the UDB to accommodate the new EQUI file received from the States. To this end, the Longitudinal Database (LDB) was created. When it went online in April of 1999, the LDB became the Bureau's official sampling frame and replaced the UDB. Initially, the LDB only contained data from reference year and quarter 1997/1 through 1998/1. Eventually, however, all data from reference year and quarter 1990/1 forward were made available. The LDB had many improvements over the UDB, including new and revised data elements, the incorporation of NAICS codes, an improved record linkage system, and the ability to conduct longitudinal (across time) analysis of the data.

North American Industry Classification System (NAICS)

Beginning in FY 1998, the Bureau implemented the North American Industry Classification System (NAICS). NAICS was developed in cooperation with our partners in the North

American Free Trade Agreement (NAFTA) and provides a consistent framework for the collection, analysis, and dissemination of industrial statistics. Under NAICS, the U.S., Canadian, and Mexican statistical agencies use the same detailed definitions to collect, summarize, and publish statistics about their respective domestic economies.

NAICS can be contrasted with the older Standard Industrial Classification (SIC) system that it replaced. NAICS represents a change in the conceptual framework of establishment classification. Unlike the SIC system, which classified establishments by the product they produced or the service they rendered, NAICS classifies establishments on a production-oriented or supply-based conceptual framework. This conceptual framework groups establishments into industries according to similarities in the processes used to produce goods or services. This supply-based conceptual framework allows establishments to be categorized on both inputs and outputs, rather than on outputs alone. It also allows the integration of every part of the production process into the measurement of productivity and the classification of industry.

NAICS is a new classification system for our modern economy and reflects the emergence of many new industries. New sectors have been added, such as the Information sector (which includes new industries such as “Internet Publishing and Broadcasting”), and the Accommodation and Food Services sector (which combined the accommodation and restaurant industries).

The change in industrial classification systems from SIC to NAICS had a profound impact on the data collected within the QCEW program. It meant recoding all eight million records in the Bureau's business establishment list. Fortunately, approximately 45 percent of the detailed SIC industries matched directly into NAICS industries and could be automatically recoded. The remaining 55 percent transferred into multiple NAICS industries and had to be recoded via the Annual Refiling Survey. Unfortunately, the recoding to NAICS for industries without a direct counterpart meant a break in the time series, and broad sectors of the economy lost some of their historical comparability. Nevertheless, this drawback of any change in industry classification system was outweighed by the many benefits of NAICS, such as the production-side framework on which it is based and the increased amount of industry detail. There are approximately 1,200 NAICS industries compared to the 1,004 SIC industries, increasing industrial detail by about 20 percent. The end result is data that are more useful to the wide variety of users the QCEW program serves.

Under NAICS, new and emerging industries (e.g., high-technology industries and services) are rapidly incorporated with planned five-year revision cycles. The first five-year revision replaced the 1997 NAICS codes with 2002 NAICS codes (The 2002 NAICS revision was necessary because the United States, Canada, and Mexico did not reach agreement on the detailed structures for the construction and wholesale trade sectors in time for the original NAICS publication in 1997). Beginning with 2001/1 data, all QCEW records had a 2002 NAICS code.

The second five-year revision replaced the 2002 NAICS codes with 2007 NAICS codes. The 2007 NAICS revision was much smaller in scope and only involved approximately 90,000 establishments covering two million employees. Of these, approximately 66,000 establishments were in "split" industries in which an existing NAICS 2002 code split into more than one NAICS

2007 code. The remaining affected industries were "direct" conversions in which a NAICS 2002 code converted directly to one NAICS 2007 code. Beginning with 2007/1 data, all QCEW records have a 2007 NAICS code.

The third five-year revision replaced the 2007 NAICS codes with 2012 NAICS codes. With the introduction of this revision, some industries were merged into new industries, some were merged into pre-existing industries, while others were split into two or more industries. Of the 1,193 detailed industries used by BLS under NAICS 2007, 200 industries were affected by the NAICS 2012 revision. As a result of the various changes, the industry count declined to 1,083. Approximately 698,000 private establishments changed industries. Beginning with 2011/1 data, all QCEW records have a 2012 NAICS code.

The fourth five-year revision replaced the 2012 NAICS codes with 2017 NAICS codes. Eleven NAICS 2012 codes were direct conversions to one NAICS 2017 code, affecting about 95,000 establishments and 3.2 million employment. Thirteen NAICS 2012 codes consolidated (rolled up or combined) into five NAICS 2017 codes, affecting about 26,000 establishments and 413,000 employment. Four NAICS 2012 codes split into seven new NAICS 2017 codes, affecting about 43,000 establishments and about 1.7 million employment that could be split into one or more new industries. There were 1,154 new index items added. Beginning with 2017/1 data, all QCEW records have a 2017 NAICS code.

Geocoding and Information Expansion Initiatives

In FY 2003, the Bureau took steps to increase the amount of information contained on the national office and State micro databases. In response to user demand, BLS began to geocode the entire business register. Geocoding is the process of adding geographic information to a file or database so that its objects can be precisely located and displayed on a map. The file must contain data that are geographic in nature (such as State, county, zip code, and street address) that can then be assigned x and y coordinates on a map. The QCEW micro data file contains a rich set of geographic information that can be geocoded, allowing States and the BLS to produce and publish sub-county employment and wage data.

In addition to geocoding information, the EQUI file was expanded with many other data elements that were contained on the State micro databases but were not being submitted on the EQUI file. The file expansion was an increase in information that could be used to improve the quality and usefulness of QCEW program data.

Contracted Annual Refiling Survey (CARS) project

In 2006 CARS began with twelve pilot States participating. A commercial vendor took over the duties of printing refile forms, stuffing envelopes, mail out and sorting returns. All forms were sent to the State, with those requiring further review separated for State processing. Electronic files of response status by UI number was provided to the State. The use of the contractor for these tasks reduced survey costs and the program is now available to all States.

MWR Print contract/ MWR Web

Beginning as a pilot program in 2007 The MWR Print Contract prints login credentials on the quarterly forms or letters for respondents to register on MWR Web. DCB oversees the MWR print contract with a private contractor who prints and mails the forms and processes the responses. All States are enrolled in MWR Web.

1.4 Responsibilities of the Participants

The QCEW Program is a Federal/State cooperative program or "Fed/State program" in which State agencies work in cooperation with the BLS to collect data and publish information derived from those data. A common set of micro data are used for State and national purposes. These programs are funded through annual Cooperative Agreements between the States and BLS.

From collection to publication, the accuracy and timeliness of QCEW data relies upon the participation of the following organizations:

State Workforce Agencies (SWAs): These State agencies are responsible for collecting the data, editing it to ensure that the quality is acceptable, and publishing analyses of the data. Both the UI tax unit and the State QCEW unit are administered by the State Workforce Agencies, but they are separate entities and have different responsibilities. The UI tax unit is primarily concerned with administering the State's unemployment insurance system. The QCEW unit is primarily concerned with collecting employment and wage data to be used for statistical purposes. State agencies collect QCEW data on the quarterly UI Contribution Report or MWR as a byproduct of the administration of the UI program.

Division of Administrative Statistics and Labor Turnover (DASLT): This office is part of the Bureau's Office of Employment and Unemployment Statistics. Also known as the Program Office, DASLT oversees the funding and operations of the QCEW Program and directs the course of program advances and methodology. Within DASLT, various branches have responsibility for different components of the QCEW program.

Current Data Analysis (CDA): This branch reviews employment and wage totals each quarter in support of QCEW publication activities. This branch also publishes the County Employment and Wages news release.

Data Collection Branch (DCB): This branch oversees all coding and data collection activities.

State Operations and Frame Research (SOFR): This branch conducts a quarterly micro-level review using longitudinal database (LDB) files (based on the EQUI) and oversees the LDB and Business Employment Dynamics (BED)-related activities.

Systems Coordination and Redesign (SCR): This group oversees fixes and enhancements to the EXPO and WIN systems. They also work on the development of a new State processing system.

Division of Business Establishments Systems (DBES): This office is part of the Bureau's Office of Technology and Survey Processing (OTSP). Also known as the Project Office, DBES is responsible for receiving data from the SWAs, processing it through the national office's information technology systems, and producing various data-release files and tabulations. DBES maintains the Longitudinal Database, and develops and maintains the national office's information technology systems.

Statistical Methods Staff (SMS): This office is part of the Bureau's Office of Employment and Unemployment Statistics. SMS is responsible for ensuring the statistical integrity of Fed/State programs. SMS consists primarily of statisticians who monitor and improve upon the statistical methodologies.

Office of Field Operations (OFO): OFO operates on two levels: at the National Office and through six regional offices.

National Office (NOs); In the national office, the Division of Cooperative Survey Programs (DCSP) part of OFO-National Office, provides coordination between the regional offices and the program office, ensuring that the SWAs are provided with the funding, equipment, and information necessary for operations.

Regional Offices (ROs): OFO stations personnel in the Fed/State branch of each regional office to ensure that the SWAs receive the resources necessary to fulfill their obligations under the cooperative agreement providing training and procedural, technical, and operational support.. The regional office also ensures the quality and timeliness of State submitted data. The regional offices are the States' primary points of contact to BLS, acting as liaison and technical arbitrator between the States and the national office.

The regional offices are Boston/New York, Philadelphia, Atlanta, Chicago, Dallas/Kansas City, and San Francisco.

Utah and Maine's State System Developers: Utah and Maine State offices developed and maintain the two standardized State processing systems as described in Section 1.6.

Electronic Data Interchange Center (EDIC): This center in Chicago collects employment and wage data centrally from multi-State companies, large payroll providers, and federal installations in order to reduce reporter burden. This central processing saves States time and money by sparing them the effort and expense of mailing out MWR and RFEW forms, collecting the data, and then entering the data from the forms into an electronic format. Once EDIC completes the processing of a company's quarterly data, it distributes the data electronically to the States. The EDIC coordinates with DASLT to target large employers and large payroll providers, which are used by some employers to maintain payroll records. DASLT also works with these large payroll providers to produce the MWR data.

1.5 Overview of Quarterly and Annual Processing

Quarterly and annual processing consists primarily of collecting and updating data, placing data on a database, and distributing data. The data must be collected in an accurate and timely manner. The database must be maintained and updated so that the data are usable and retrievable. Once collected and stored, the data must be made available to the users in such a way that confidentiality is preserved and the integrity of the data are not compromised.

The remainder of Section 1.5 consists of detailed diagrams showing the processing flow of the QCEW Program. EXHIBIT 1A shows a diagram of the main processing flow for the whole program. The numbered paragraphs that follow explain the numbered activities on the diagram. See Appendix A for all detailed processing flow diagrams.

1.5.1 Main Processing Flow

The QCEW is a large, complex program with many outside participants that contribute to the data flow. To minimize complexity and provide a solid understanding of the basic data flow, the flowchart given below and those in Appendix A portray the processes for a single quarter. Please be reminded that States update/process more than one quarter at a time. The main processing flow is given with peripheral processes detailed later in this manual. Peripheral processes occur at activity 4, 5, 21, 29, and 33 of the main processing flow. Activity 4 receives data from four peripheral processes. These peripheral processes flowcharts are available in Appendix A and the topics included are covered in the following chapters.

- Special Processing for Multi-Unit Employers (Chapter 3)
- Multiple Worksite Central Reporting (Chapter 4)
- Central Reporting of Federal Data (Chapter 4 section 6)
- MWR Web Internet Data Collection (Chapter 4 section 8)
- Annual Refiling Survey (Chapter 6)

Activity 5 receives data from peripheral process E, geocode files. Please refer to section 1.3 and Appendix V for more information about the geocode files.

DBES provides data files and reports to BEA and CES as the States' EQUI data are received (peripheral process F), corrected, and/or updated (peripheral process G). After the EQUI clean-up due date for each quarter, one additional BEA deliverable and the ETA/LAUS deliverables are generated and validated by DBES staff. They are produced both in print and file versions that are due to BEA, ETA, and LAUS by the 5th of the month following the EQUI clean-up deadline for that quarter (peripheral process I). These are included as peripheral process F.

Activity 31 passes data from the main processing flow to the Longitudinal Database peripheral process. The business establishment micro data that are summarized to produce the macro-level Business Employment Dynamics (BED) data are the same source of data for the Bureau's LDB. Potential New MWR Reporters is discussed in section 3.3. The flowcharts are also in Appendix A. Explanation for each activity in the main processing flow is provided in the text immediately following the flowcharts in EXHIBIT 1A Main Processing Flow.

EXHIBIT 1A Main Processing Flow

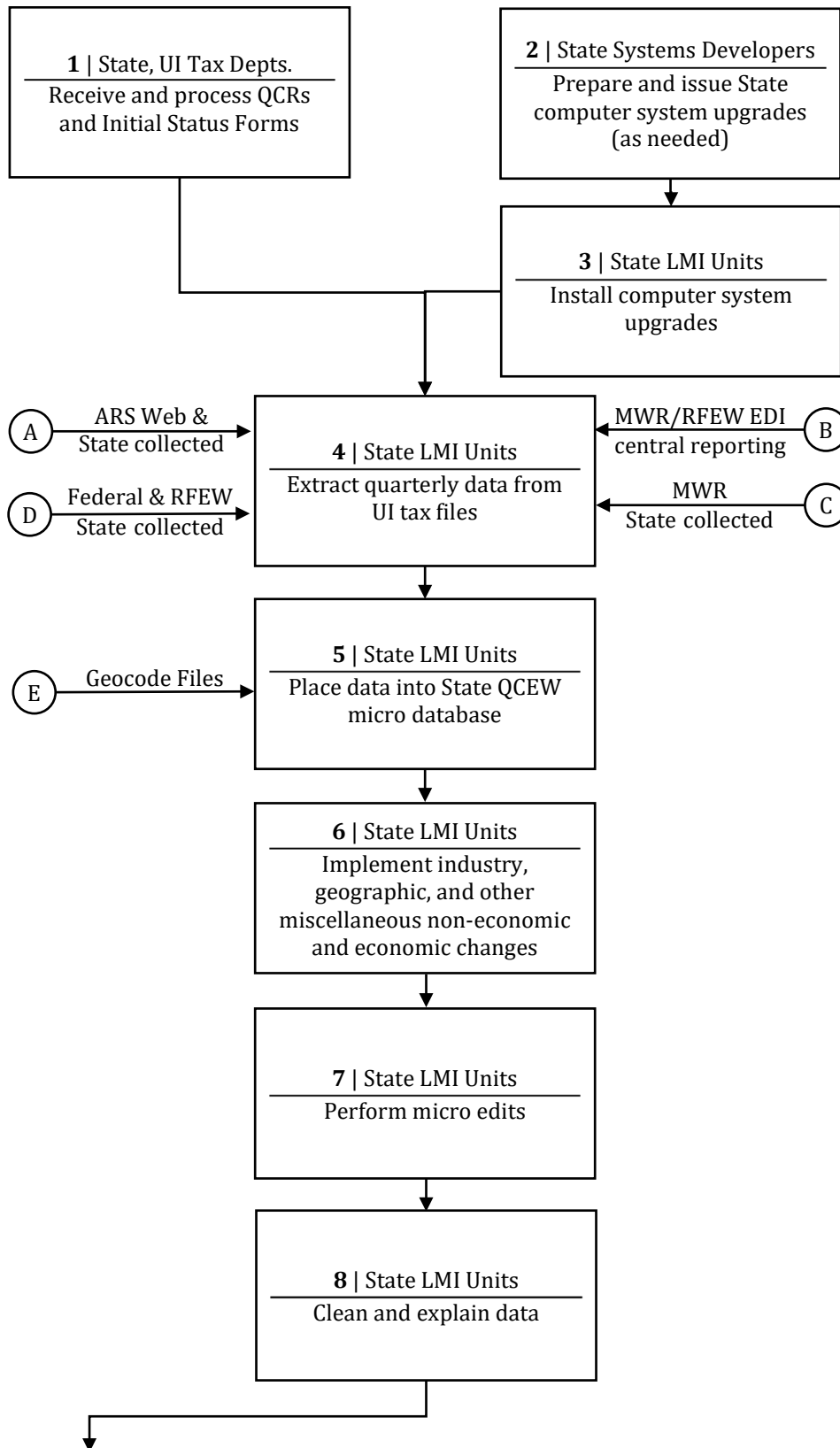

EXHIBIT 1A (continued) Main Processing Flow

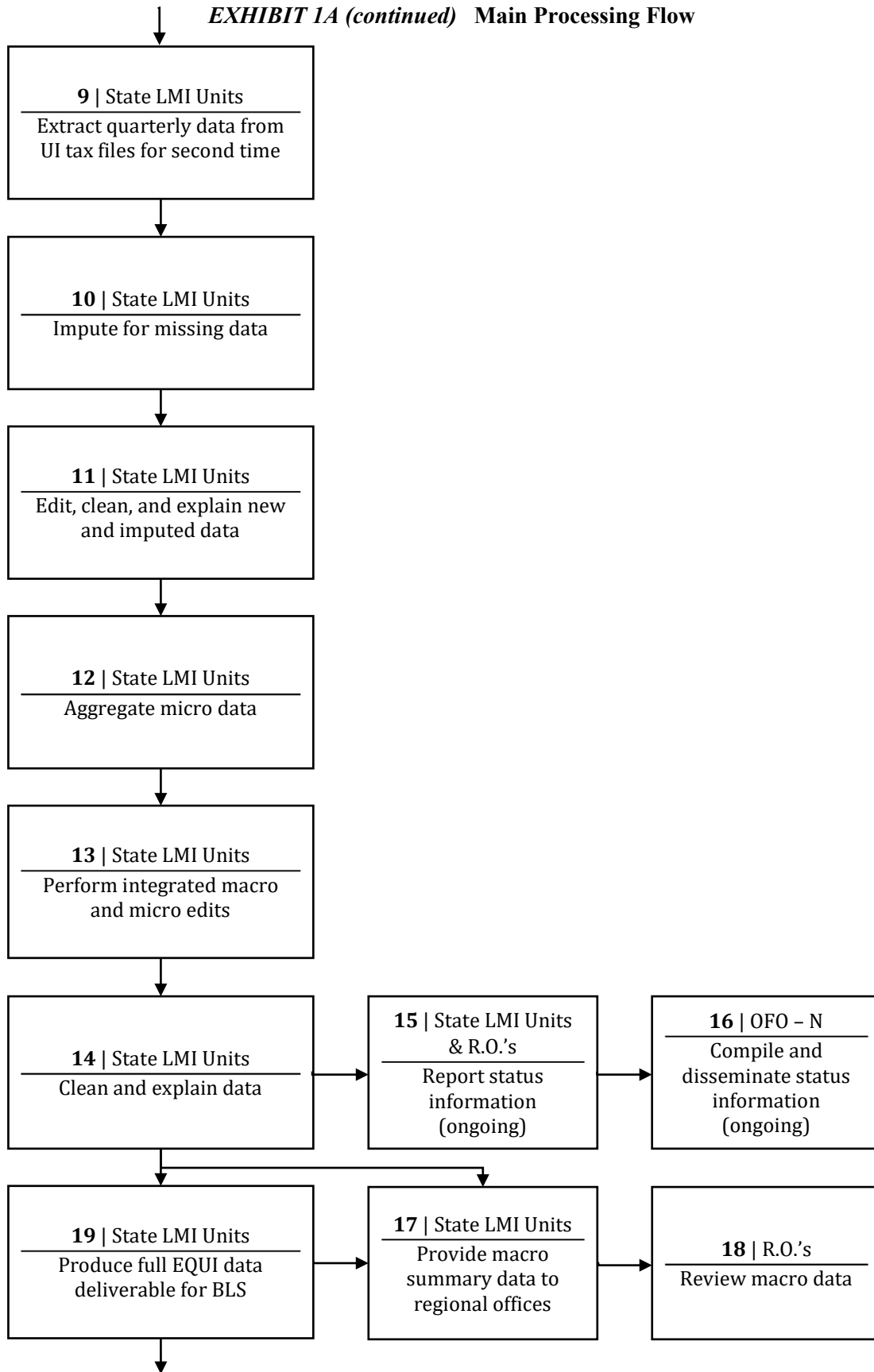

EXHIBIT 1A (continued) Main Processing Flow

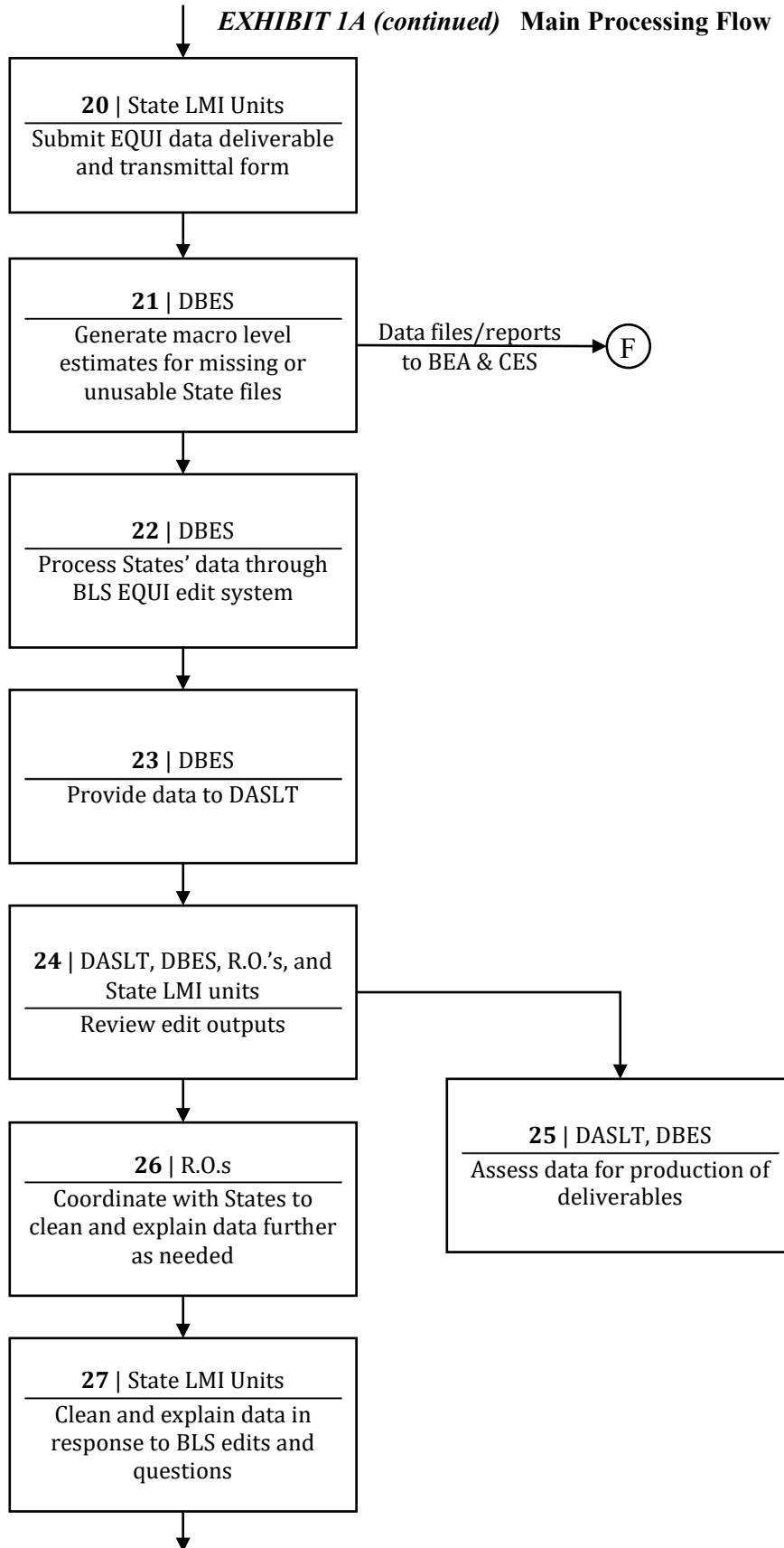
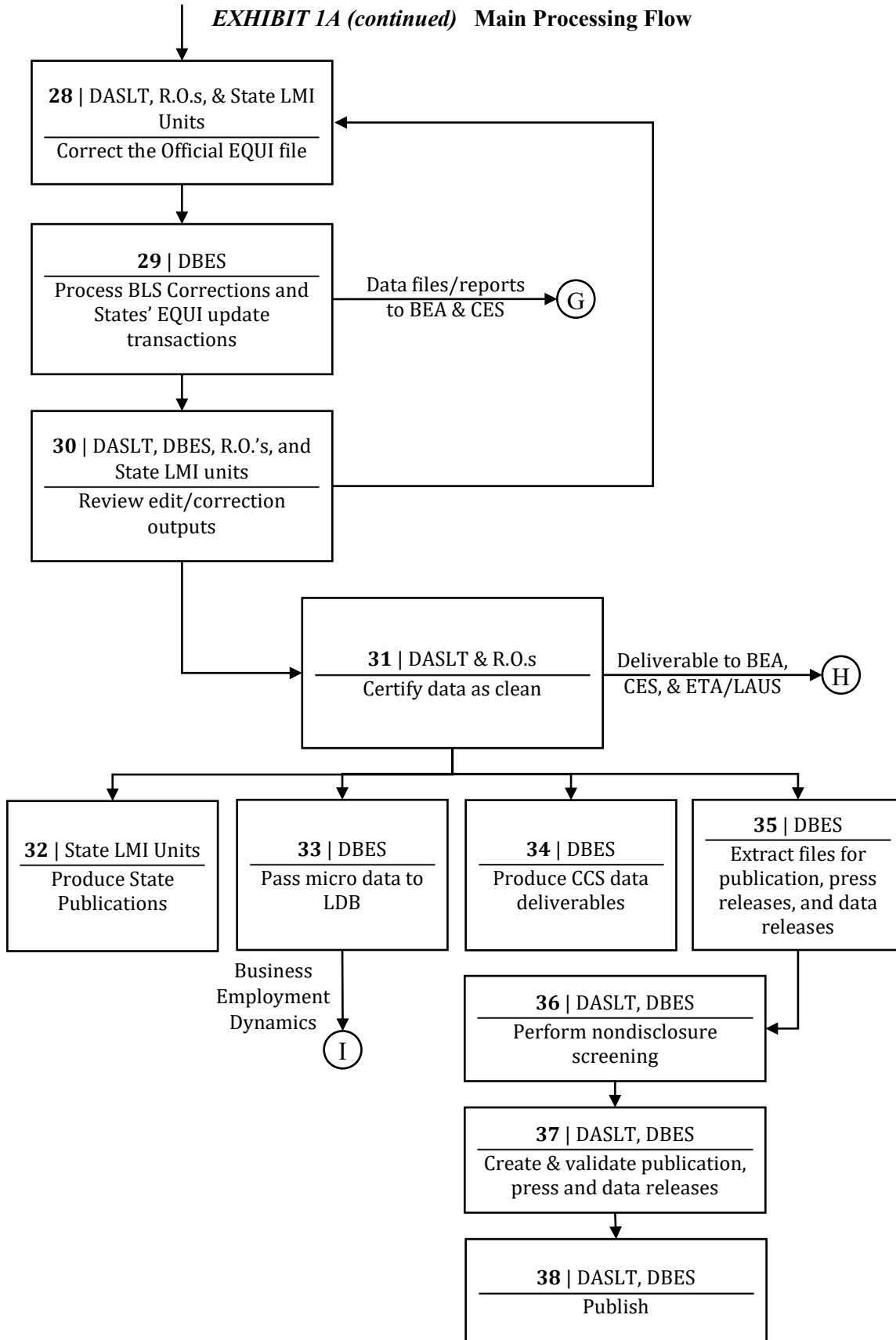

EXHIBIT 1A (continued) Main Processing Flow



1. Receive and process QCRs and Initial Status Forms

The QCEW program is a census of all employers subject to State Unemployment Insurance (UI) laws, supplemented with additional data collected for statistical purposes only. Most of the QCEW data are collected as a by-product of the States' administration of the Unemployment Insurance taxes. Employers file Quarterly Contributions Reports (QCRs) with their State UI tax department, which is separate from the Labor Market Information (LMI) unit that provides data to BLS under guidelines set in the Cooperative Agreement. (Both departments are part of the larger State Workforce Agency). The QCRs provide monthly employment, quarterly wages, and UI tax information. New employers file Initial Status Forms with the State UI tax unit to initially register their business. These initial forms provide basic business identification and classification information to establish a UI account. UI tax administration, the QCRs, and the Initial Status Forms are all under the oversight of the Employment and Training Administration (ETA). The QCRs and the Initial Status Forms are State-specific; neither are standardized across States. UI tax units generally handle follow-up with employers for delinquent and missing data for these two forms.

2. Prepare and issue State computer system upgrades

Two standard State processing systems are available to the States (SWAs) for conducting the QCEW program. One is the EXPO system maintained by Utah State staff; the other is the WIN-202 system maintained by Maine State staff. Upgrades to the systems are released regularly and non-scheduled fixes are issued as needed. The upgrades incorporate initiatives and enhancements requested by BLS plus improvements suggested by State users. The EXPO system is a mainframe system. It is available for access centrally in a service center environment and as a distributed product for installation locally in the States. The WIN-202 system is a client/server system that is installed and operated locally in client States.

3. Install computer system upgrades

States install or implement the system upgrades after receipt, but no later than the time allotted by the Cooperative Agreement. EXPO States that are operating at the service center are automatically upgraded. The State developers from Utah and Maine often assist in the installations.

4. Extract quarterly data from UI tax files

A quarter's processing begins with the first extract of data from the UI tax files. This extract contains data from the new, current quarter as well as data from the prior quarter. Because the UI tax files are State-specific, the States' QCEW programs that pull data from these files must also be State-specific.

5. Place data into State QCEW micro database

The extracted UI tax data are placed in the State's QCEW micro database (State system). Other sources of QCEW data are collected by the QCEW program itself. These data include:

- A. Annual Refiling Survey (ARS) data
- B. Multiple Worksite Report (MWR) and Federal (RFEW) data collected centrally from multi-State reporters by the EDI Center
- C. MWR data collected directly by the State
- D. Federal (RFEW) data collected by the State

6. Implement industry, geographic, and other miscellaneous non-economic and economic changes

This information comes from various sources including the Annual Refiling Survey, unclassified account information solicitation (NCA), UI tax information updates, and independent research. State analysts must determine if the changes are economic or non-economic. Economic changes are revisions that capture a change occurring in the quarter first attributed the new codes. Non-economic changes are included on the code change supplement; while economic changes are implemented in the appropriate open quarter through to the most current quarter. The code change supplement implementation is detailed in the cooperative agreement.

7. Perform micro edits

States have several options for editing the quarterly data within their standardized system. The options include:

- running micro edits prior to running a fully integrated micro/macro edit
- starting with a full integrated micro/macro edit
- using a combination of approaches tied to the timing of the multiple UI tax extracts

This flow describes the first option. In the micro edits, the data are edited by establishment. An establishment record is checked for valid values. This verification includes checks for the reasonableness of the data (both within the quarter and across quarters).

8. Clean and explain data

The State reviews edit failures and warning flags. The data must be corrected or explained as needed. Standard comment codes are used to explain unusual data. Narrative comments can also be entered into the system.

9. Extract quarterly data from UI tax files for second time

States extract current quarter data from the UI tax files for a second time in the quarterly processing cycle to pick up newly reported and posted data.

10. Impute for missing data

Some employers' data will be missing, mostly delinquent UI tax filers. Prior to summarizing and reviewing data at a macro cell level, States must impute for the missing micro (establishment level) data.

11. Edit, clean, and explain new and imputed data

As earlier, the State reviews any edit failures and warning flags. The data must be corrected or explained as needed. Standard comment codes are used to explain unusual data, and narrative comments can also be entered into the system.

12. Aggregate micro data

The micro data are summarized by macro cell (county, ownership, industry combination) prior to running an integrated micro/macro edit.

13. Perform integrated macro and micro edits

The data at a macro cell are checked for reasonableness – for example, the cell level data are checked for large fluctuations in employment or wages between quarters. The integrated edit displays both the summary data for the cell as well as the micro level records that likely caused the macro level edit flag.

14. Clean and explain data

The State reviews its edit results. The data must be corrected or explained as needed. Standard comment codes are used to explain unusual data. All corrections are made to micro level records with macro level data being re-aggregated as needed from the micro data.

15. Report status information (ongoing)

Shortly before the due date for producing the quarterly file deliverable for BLS, the State formally begins reporting status for the quarter. The status reporting is an ongoing process typically with a report due every two weeks or so on a schedule announced by OFO. The status report includes such information as the prognosis for meeting the deliverable due date, clean-up status for the prior quarter(s), and any changes in the State's processing environment. The States report the requested information to their regional offices. The regional offices compile and submit to the national office the information for their States.

16. Compile and disseminate status information (ongoing)

The Office of Field Operations (OFO) in the national office receives the reports from the regional offices and issues a consolidated status report for all States.

17. Provide macro summary data to regional offices

The State generates a file of macro data and sends it to the regional office.

18. Review macro data

The regional office enters the macro summary data into an Excel spreadsheet, the 'QCEW/CES Comparison Sheet, to compare the State QCEW employment data against State CES data and to compare current year QCEW trends against prior year QCEW patterns in both employment and wages. The State and regional office also perform these two steps (generating macro summary data and using it for comparison) before generating the EQUI update file.

19. Produce full EQUI data deliverable for BLS

Approximately four months after the end of the reference quarter, States produce their key QCEW deliverable for BLS: the Enhanced Quarterly Unemployment Insurance (EQUI) file. This file contains all micro data records for the applicable reference quarter plus update transactions for prior quarters.

20. Submit EQUI data deliverable and transmittal form

States submit their EQUI file to DBES. Three transmittal methods are possible depending on the State system (refer to Section 12.3). For EXPO States operating at the service center, DBES simply accesses the applicable files at the service center. For other States, EUS Web and File Transfer Protocol (FTP) are options. All States complete and submit a transmittal form that

gives notice of the data submittal and includes certain pieces of information necessary to facilitate DBES processing.

21. Generate macro level estimates for missing or unusable State files

If States have not submitted the EQUI file by the deadline date, the national office (DBES) generates macro level estimates.

22. Process States' data through BLS EQUI edit system into the EQUI database

Each State's EQUI file is processed through the national office edit system. A set of reports is produced. Some are error reports requiring further review; some are reports that count, tabulate, and list the data in various ways for informational purposes.

23. Provide data to DASLT

As the States' EQUI data are received, DBES also generates macro level aggregations and provides the macro level files to DASLT for their data uses. DBES loads micro and macro data to the ES-202 Database (EDB), a client-server system on the BLS LAN, for use by the analyst staff in the national office and the regional offices.

24. Review edit outputs

DASLT, DBES, the States and the regional offices all play roles in reviewing the BLS edit outputs and identifying potential problems in the data.

25. Assess data for production of quarterly deliverables

Prior to producing these data, an assessment must be made of which States' data are usable and which States' data are unusable or delinquent.

26. Coordinate with States to clean and explain data further as needed

The regional offices coordinate with their States to perform data clean up in response to the BLS edits. The most critical errors are addressed first.

27. Clean and explain data in response to BLS edits and questions

In response to the BLS edits and any guidance or priorities given by the regional offices, States research the data further. The data must be corrected or explained as needed. Standard comment codes are used to explain unusual data in the State system, narrative details should be provided on responses to BLS questions. All corrections are made to micro level records on the State system and provided in response to BLS questions.

28. Correct the Official EQUI file

BLS corrections to the official EQUI file are made based on information provided by States in response to BLS questions or other errors. BLS may alternatively require the State to submit a subset with the updated transactions. BLS-required update transactions should be submitted on the subset shortly after BLS subset approval notification is received. The official deadline is specified in the cooperative agreement. Beyond BLS required updates, States are permitted to transmit updates on the subset determined to be critical inclusions. In preparing the subset, States make the corrections in their State database and then run additional steps that create matching update transactions for the BLS database. As with the full EQUI file, three transmittal

methods are possible for the EQUI update transactions file. Due to the cost associated with subsets, States are encouraged to coordinate with regional offices to make BLS corrections instead. Note that updates in the State system will automatically be included in the next quarter's official EQUI deliverable.

29. Process BLS corrections and States' EQUI update transactions

DBES processes the BLS corrections and EQUI updates from the States. Following each, an additional set reports is produced reflecting the revision to the EQUI.

30. Review edit/correction outputs

Similar to earlier in the cycle, DASLT, DBES, the States, and the regional offices all play roles in reviewing the national office edit outputs and identifying any remaining problems in the data. Minor problems may be held for submission with the next quarter's EQUI deliverable or submitted as an additional BLS correction or State update file. Regional offices and the national office consult to determine the best course of action.

31. Certify data as clean

Once BLS is satisfied with the data, they provide notice to States and DBES that the EQUI data stored in the EDB is considered "clean." This is, in actuality, an interim designation that must be reconfirmed in the future quarters since update transactions occur concurrently with the data submittals for future quarters.

32. Produce State publications

States publish QCEW data in various formats and on various schedules.

33. Pass micro data to LDB

The business establishment micro data that are summarized to produce the macro-level QCEW data are the same source of data for the Bureau's LDB.

34. Produce CCS data deliverables for users

Code Change Supplement (CCS) data are implemented in the time frame detailed in the cooperative agreement. The CCS data show the changes in classification codes (industry, county/township, and ownership) that are discovered through the ARS and held for implementation. DBES produces tabs and files showing units and employment that have shifted from one cell to another.

35. Extract files for publication, press releases, and data releases

BLS regularly produces publications, press releases, and data releases. Data are pulled at the end of the quarterly processing for quarterly releases.

36. Perform nondisclosure screening

Nondisclosure screening is performed for publication, press releases, and other uses. Nondisclosure screening is run so that individual company data are not revealed or discernible in published data.

37. Create and validate files for publication, press releases, and data releases

DBES and DASLT review summary counts of units, employment, and wages to verify that the files being used for releases are complete and current. DASLT analyzes the data for publication, as well as preliminary tables DBES produces for review. Publication tables, press release tables, and non-disclosure datasets are produced. DBES makes changes in content or format that have been specified by DASLT and runs the programs that produce the publication tables. DASLT prepares the press releases and they are issued through OPUB and disseminated.

1.6 Using Standardized Processing Systems

It is imperative that States process all of their data through a standardized system. Standardized systems allow for centralized system development and issuance of system upgrades, fixes, and changes. States only need to install the new version and do not need to program the changes themselves. Within the service-center environment, States always have the most current version and do not need to install the upgrades themselves. Processing all data through standard systems ensures uniform and consistent processing across States and efficient application of system upgrades and changes. Collectively, this results in increased reliability and accuracy of the data.

Two standard systems are available to the States for processing data in the QCEW program.

- 1) EXPO: A mainframe system maintained by State staff in Utah. EXPO is available for access centrally in a service center environment or as a distributed product for installation locally in the States.
- 2) WIN: A client/server system that is installed and operated locally in client States but maintained by State staff in Maine.

There are regular releases of upgrades to these computer systems. Non-scheduled fixes are also issued as needed. The upgrades incorporate initiatives and enhancements requested by BLS plus improvements suggested by State users. Non service center States install or implement the system upgrades once received and complete their installation within the timelines stipulated by the annual cooperative agreement. The State developers from Utah and Maine often assist in the installations. Installation is done automatically for service center States.

States have several options for editing the quarterly data within their standardized system as described in Section 12.1.

1.7 Definitions - Basic Terms

The following terms are key concepts for the collection and use of data on the State system and on the EQUI. These definitions also relate to the Code Change Supplement (generated from State and BLS micro files as described in Chapter 11).

Auxiliary Units - Under NAICS, auxiliary establishments are classified with a NAICS code according to the activity of the auxiliary establishment itself. This is in keeping with the conceptual framework upon which NAICS is based; namely, that establishments are classified based on their production processes. As an example, a warehouse that serves a primary unit within the same enterprise will be assigned the NAICS code for warehouse. Thus, the industry classification of the primary unit (car assembly plant, telephone communications, etc.) cannot be discerned from the NAICS code assigned the auxiliary unit. (See Chapter 2 for more information regarding industry coding.)

CARS – Contracted Annual Refiling Survey. A centralized system to augment the annual refiling survey performed by contractors with the BLS.

Contributions - All States finance unemployment benefits through self-insurance or from unemployment insurance taxes, or contributions. Contributions come from two sources: 1) from subject employers based on the wages of their covered workers, and 2) in some States, from the employees themselves.

Total contributions, therefore, are a composite of the employer's contributions and, where applicable, the employee's contributions.

Employee Contributions - Employee contributions are the unemployment insurance taxes required by some State unemployment compensation laws to be deducted from an employee's pay by the employer and paid with the employer's contribution to the State agency.

Employer - The employer is the legal entity that either 1) pays the unemployment insurance tax, or 2) elects or is required to reimburse the State unemployment fund for unemployment insurance benefits costs in lieu of paying the UI tax. In some cases, the employer is equivalent to the establishment or the reporting unit, while in others the employer will include several establishments or reporting units.

For the purpose of the QCEW program, the government employer is the organizational unit, such as the department, agency, or instrumentality, responsible for a function of government.

Employer Contributions - FUTA defines employer contributions as "payments required by a State law to be made into an unemployment fund by any person on account of having individuals in his (or her) employ." In general, employer contributions include any monies collected by tax, surcharge, etc. that are deposited into the State's trust fund and may be used to calculate tax rating. Unemployment insurance taxes are levied or assessed on taxable-subject employers at

either a standard rate or some other rate determined under the tax rating provisions (see definition of Tax Rating) of the individual State's laws. The rate is usually defined as a certain percentage of the taxable wages paid by the employers during the rate year for services performed in covered employment. Taxes that are paid by employers at a flat rate with no regard to either experience rating or benefit reimbursement are also considered employer contributions.

Included in this definition are unemployment insurance taxes that may be assessed on employers under special provisions of State laws that become effective because of emergency conditions or because of a low balance in the State trust fund accounts that are used to finance benefit costs.

Not included in this definition of employer contributions are:

1. Any tax, surcharge, etc. that is used to pay off the interest on a loan from the Federal government to the State trust fund and is required by Federal law to be deposited outside the unemployment trust fund.
2. Any temporary excise tax or permanent surcharge tax.
3. The 0.8 percent (administrative financing) excise tax paid to the Federal government since January 1, 1983, by all employers of one or more workers in 20 weeks' time during a calendar year in covered industries. (This tax will revert to 0.6 percent when the outstanding indebtedness of the Extended Unemployment Compensation account to general revenue is repaid or removed.)
4. Payments instead of contributions by certain nonprofit organizations, State, and local government instrumentalities that finance benefit costs on a reimbursing basis.
5. Voluntary contributions (paid by employers in some States to be credited to their experience-rating accounts to obtain rates that are more favorable for future periods).

Employment - Employment for a given month is the number of covered workers who earned wages during the pay period that includes the 12th of the month. A reporting unit should report as employment the number of covered workers who worked during or received pay for any part of the payroll period covering the workweek that includes the 12th of the month, the first of the two semimonthly payrolls, the monthly payroll, or the payroll of any other type that includes the 12th of the month. Where more than one type of payroll is in use, the reporting unit should report the total number of employees on all types of payrolls that include the 12th of the month.

The employment count should include all corporation officials, executives, other supervisory personnel, clerical workers, wage earners, persons on paid vacations or paid sick leave, pieceworkers, part-time workers, and workers earning wages that are nontaxable because the taxable wage limit has been exceeded.

The employment count should exclude workers who were on leave without pay or who earned no wages during the applicable pay periods because of strikes, work stoppages, or temporary

layoffs. Workers who earned wages during the month without earning any during the applicable pay periods should not be counted in the employment figures, although the wages are reported.

Note: Reporting units sometimes list erroneously as employment the total number of persons who have earned wages at some time during the quarter, while others fail to report, in the last quarters of the year, workers whose wages have gone above the taxable wage limit. Efforts should be made to eliminate these and other errors in the reporting of employment, possibly by means of a once-a-year notice mailed with the blank contribution report. This notice should call attention to the kind of data to be reported as employment, and should be in more specific form than the instructions appearing on the contribution report.

Enterprise - An enterprise consists of all establishments having more than 50 percent common direct or indirect ownership. In a situation where Company A owns more than 50 percent of Company B, and Company B owns more than 50 percent of Company C; Company A would directly own Company B – and indirectly own Company C through Company B's direct ownership of Company C. The BLS does not gather employment or wage data for enterprises.

Establishment - An establishment is an economic unit, such as a farm, mine, factory, or store that produces goods or provides services. It is usually at a single physical location and engaged in one or predominantly one type of economic activity for which a single industry code is applicable.

Where a single physical location encompasses two or more distinct and separate economic activities for which different industry codes seem applicable, such activities should be treated as separate establishments and classified in separate industries, provided it is determined that:

1. No one industry description in the NAICS system includes such combined activities;
2. The employment in each such economic activity is significant;
3. Such activities are not ordinarily associated with one another at common physical locations; and
4. Separate reports can be prepared on the number of employees, their wages and salaries, and other establishment-type data for each of the activities.

In the government sector, the term "installation" generally is used instead of establishment.

Inactive Employer - A unit, not currently reporting employment or paying wages subject to the State's unemployment compensation law, that has been terminated, administratively inactivated, or granted permission to suspend filing contribution reports or payment in lieu of contribution reports (seasonal employers excluded); or who paid no wages during the eight (8) calendar quarters immediately preceding the due date of the ETA 581, the Contribution Operations Report. The quarter being reported or validated is included in this time span of eight (8) quarters.

States should be careful not to inactivate a unit for a reference year/quarter in which they were active. For example, if a unit was active in the first quarter but went out of business during

April, the unit should be reported on the first quarter EQUI file. Furthermore, if the account went out-of-business or was terminated on April 6 and did not have employment during the pay period including the 12th of the month, but paid wages during the period of April 1-6, the unit should also be reported in the second quarter. This is an example of a unit that should be included on the EQUI file because it paid wages in the quarter after it went out-of-business. Similarly, if back wages are paid after an account is terminated, it should be reactivated or set up as a new account and the wages reported during the quarter that they were paid.

These definitions in no way preclude immediate inactivation of an account when either the employer notifies the agency or a determination is made that the employer has ceased paying wages. In the absence of the administrative inactivation of the "no wages paid" employer, a limit is imposed on the length of time that such an employer can be included in the SWAs "active employers" workload count and in the EQUI file.

Industry Code - Each establishment is assigned a NAICS industry code based on the processes it uses to produce goods or services. The NAICS system represents a change in the conceptual framework of establishment classification. Unlike the older Standard Industrial Classification (SIC) system, which classified establishments by the product produced or service rendered, NAICS is based on a production-oriented or supply-based conceptual framework. This conceptual framework groups establishments into industries according to similarity in the processes used to produce the goods or services. The NAICS system completely replaced the older SIC system.

NAICS covers the entire field of economic activity of today's modern economy. Establishments are classified into one of the following 20 sectors (refer to Appendix P for the NAICS Aggregation Tree):

- Agriculture, Forestry, Fishing, and Hunting
- Mining
- Utilities
- Construction
- Manufacturing
- Wholesale Trade
- Retail Trade
- Transportation and Warehousing
- Information
- Finance and Insurance
- Real Estate and Rental and Leasing
- Professional, Scientific, and Technical Services
- Management of Companies and Enterprises
- Administrative and Support and Waste Management and Remediation Services
- Educational Services
- Health Care and Social Assistance
- Arts, Entertainment, and Recreation
- Accommodation and Food Services

- Other Services (except Public Administration)
- Public Administration

Descriptions of the detailed industry codes for which data are submitted on the EQUI file can be found in the NAICS manual.

Please note that this method of classification is not dependent upon the type of ownership. With NAICS, as with the SIC system, owners may include such diverse legal organizations as corporations, partnerships, individual proprietors, government agencies, joint ventures, etc. Government establishments, therefore, are classified by their primary economic activity, rather than by type of ownership. (See Section 2.1.5.)

QCEW data for the period from 1975 through 1987 were coded according to the 1972 Standard Industrial Classification (SIC) Manual (including the 1977 amendments). QCEW data for the period from 1988 through 2000 were coded according to the 1987 SIC Manual. Beginning with data for first quarter 2001, QCEW data were collected and made available under the 1997 North American Industry Classification System (NAICS). From the first quarter 2002, SIC codes were no longer actively coded on the State micro database files and the NAICS codes were updated to reflect the 2002 NAICS revision. Beginning with first quarter 2007, NAICS codes were updated to reflect the 2007 NAICS revision, and beginning with first quarter 2017, NAICS codes were updated to reflect the 2017 NAICS revision.

Nontaxable Wages - Nontaxable wages (sometimes called excess wages) are that part of an employee's total wages that is in excess of wages that are taxable under the State unemployment insurance law.

Number of Wage Records - The number of wage records or the wage record count for an employer is the number of names (records) appearing on his/her wage report for the quarter. Such a report (see EXHIBIT 3B) accompanies the contribution report in all States (except New York). This information is required for the computation of unemployment insurance benefits. Because of employee turnover, the number of wage records (or wage record count) for a quarter may exceed substantially the employment figures for any month of the quarter.

Organization Type Indicator - The legal form of the organization used for tax purposes by the establishment. It is valid for the private sector (Ownership code 5) only. This code is used on Status Determination Forms to solicit information from private sector establishments concerning their organizational structure.

Ownership - Reporting units are classified by ownership according to legal proprietorship – Federal, State, or local government, or private industry – rather than by type of economic activity. (See Section 2.1.4 for the specific ownership codes to be used in State systems and the EQUI file.) Regardless of type of industrial activity, each establishment must carry a code number identifying public or private ownership to distinguish between public and private activities. These codes are used with the other classification codes to preserve the continuity and usefulness of historic data. When tabulating QCEW data, the term "Government" is used to include all government-owned activities (Federal, State, and local), regardless of industry code,

while the term "Public Administration" is used only for those legislative, judicial, administrative, and regulatory activities not having a counterpart in private industry.

Predecessor - The UI/RUN under which an establishment was previously reported. For establishments that change from one owner to another, the predecessor record typically has a different UI number. For establishments that are reported differently within an existing UI account (e.g. breakouts or consolidations), the predecessor record usually has the same UI number but a different RUN. The purpose of predecessor (and successor) UI/RUN coding is to identify establishments as continuous, especially when they change ownership or UI number.

Primary County - A primary county is defined as the county of largest employment for a multi-county employer. All other counties with employees of that multi-county employer are secondary counties. The purpose of finding the primary county is for the purpose of assigning the county code to multi-establishment employers who refuse to break out or who do not meet the criteria for a breakout.

Reporting Unit - A reporting unit is the economic unit for which data are submitted on the employer's contribution report, Multiple Worksite Report, or employment and wages report (for a government entity or nonprofit organization, since neither may be subject to payment of quarterly contributions). The reporting unit should be the smallest individual establishment or installation that is identified by the contribution report or by a Multiple Worksite Report.

Reporting Unit Number – The Reporting Unit Number is a unique identifier assigned to each reporting unit of an employer that has two or more reporting units. The Reporting Unit Number should be assigned consistently between the State systems and the EQUI files submitted to the national office. The same identifier should also be assigned to the same reporting unit consistently across quarters so that the unit can be easily identified across time. The Reporting Unit Number should never be reused under the same UI Account Number. A Reporting Unit Number of "00000" should be assigned to multi-unit master account records and to single unit records. (Refer to Chapter 3 for more information.)

In certain cases, two or more establishments are combined to make up one reporting unit. This typically occurs when establishments owned by the same employer are engaged in the same economic activity in the same county. Whenever possible, individual establishment data should be collected and reported.

Successor - A unit that is now reported (or that will be reporting) under one UI Account Number or Reporting Unit Number, but was previously being reported under a different UI Account Number/Reporting Unit Number configuration. The purpose of successor (and predecessor) UI/RUN coding is to identify establishments as continuous, especially when they change ownership or UI number.

Tax Rating - Tax rating is the process of determining the contribution rates of individual employers on the factors specified in a State's unemployment insurance law. Experience rating determines contribution rates based on the employer's experience with respect to unemployment. Conversely, some States allow certain nonprofit or governmental units to pay taxes at a flat rate

with no regard to either their experience rating or to the reimbursement of benefits paid to their former employees.

Taxable Wages - Taxable wages (sometimes called net wages) for a quarter are that part of total wages that is subject to the unemployment insurance tax provision of the State unemployment insurance law. Taxable wages are reported by employers who are subject to tax rating provisions, but are not reported by reimbursing subject employers. In some States there are certain government units or nonprofit organizations that are taxed at a fixed percentage of the total payroll, with no regard to their experience ratings or to the reimbursement to the UI fund for benefits paid to their former employees. For such employers, taxable wages should be identical to total wages.

Total Wages - Total wages (sometimes called wages or gross wages) for a quarter are the total amount of wages paid or payable (depending on the wording of the State law) to covered workers for services performed during the quarter, on all the payrolls of whatever type during the quarter. Bonuses paid are included in the payroll figures. Also included, when furnished with the job, is the cash value of such items as meals, lodging, tips and other gratuities, to the extent that State laws and regulations provide. Total wages include both taxable and nontaxable wages. Total wages are reported by both taxable and reimbursing subject employers.

1.8 Coverage of the QCEW Program

Coverage under State Unemployment Insurance Programs

State unemployment insurance programs, the primary source of QCEW covered employment and wages data, have relatively comprehensive coverage in the United States labor force. Approximately 96 percent of the wage and salary civilian labor force and 98 percent of nonagricultural employment are covered by State UI laws, and so are reflected in QCEW data.

States establish their own unemployment insurance coverage provisions, generally in accordance with FUTA. The FUTA establishes minimum coverage standards that States must meet to have an approved UI program. FUTA provisions determine which employers are subject to Federal unemployment insurance taxes and designate certain types of services that must be covered under State UI laws to meet Federal approval. Specific coverage provisions of State UI laws have been influenced by the FUTA through tax incentives. The incentives allow employers who pay UI contributions under federally approved State unemployment insurance law to credit their State contributions against a specified percentage of the Federal tax.

Coverage exclusions in the FUTA, however, do not preclude a State from covering the excluded class or category of workers under their own State laws. Many States have chosen to expand their coverage provisions beyond the FUTA minimum standards in certain areas. A summary of common coverage exclusions is provided below. Detailed UI coverage information can be found in the *Comparison of State Unemployment Insurance Laws* maintained by the U.S. Department of Labor's Employment and Training Administration.

Both federal and State UI coverage laws are subject to change at any time when existing laws are amended through the legislative process or reinterpreted through judicial action. If State QCEW staff has a question about their State's policy in a particular area, they should contact their UI tax unit.

Common Exclusions from UI Coverage

1. As defined by federal and State UI laws, employment is the hiring of workers by others for wages. Self-employed individuals are therefore excluded from coverage. Incorporated self-employed persons, however, are covered because corporations are recognized as separate legal entities from the individual, thereby allowing the individual to be an employee of his/her own corporation.
2. Some coverage exclusions result from the scope in which an "employer" is defined. The FUTA defines an employer generally as one who has a quarterly payroll of \$1500 in the calendar or preceding year or who has one worker for 20 weeks.

The definition of employer differs for agriculture, domestic service in households, and nonprofit organizations, as noted below.

- Agriculture – The FUTA designates coverage of agricultural employers having ten or more workers in twenty weeks, or a payroll of \$20,000 or more in any quarter. Some states have more expansive coverage of agricultural employment. Farm owners/operators are excluded from coverage in all States.
 - Domestic Service – The FUTA designates coverage of domestic help in private households, social clubs, and college fraternities and sororities that pay wages of \$1000 or more in a quarter. Some states have more expansive coverage of domestics.
 - Nonprofit Organizations – The FUTA designates coverage of nonprofit organizations with four or more employees in twenty weeks. Almost half of the States have elected more expansive coverage, typically covering any organization with even one employee in twenty weeks. Ministers employed by religious organizations to perform ministerial duties are excluded from nonprofit coverage in all States.
3. The FUTA and State UI laws also specify certain categories of employment as not covered. States can choose to extend coverage to a category that is excluded under the FUTA. Common exclusions across States are noted below.
 - Minor children employed by their parents, or parents employed by their children, are excluded from coverage in all States.

- Railroad workers are excluded from coverage in all States. They are covered by a special Federal unemployment insurance program administered by the Railroad Retirement Board.
- U.S. Armed Forces military personnel are excluded in all States. They are covered under a separate Federal program, Unemployment Compensation for Ex-Servicemen (known as the USX program).
- State and local government elected officials; members of the judiciary, State national and air national guardsmen, temporary emergency employees, and policy and advisory positions are excluded in most States.
- College and university students employed by the school at which they are enrolled, such as work-study students, are excluded from coverage in all States. Most States also exclude student nurses and medical interns employed by hospitals as part of their professional training program.
- Insurance and real estate agents paid only by commission are excluded from coverage in most States.

Federal Service Covered by Unemployment Compensation for Federal Employees (UCFE)

The scope of the QCEW program also includes all federal civilian employees covered by the UCFE program. Virtually all federal civilian employees are covered under UCFE with the exception of some specifically excluded types of federal service listed in 5 U.S.C. 8501. Coverage policy and determinations of what constitutes “Federal service” and “Federal wages” under UCFE are made by the Director of the Unemployment Insurance Service of the Employment and Training Administration, as delegated by the Secretary of Labor. When the Unemployment Insurance Service (UIS) issues a coverage ruling, it is published in the Federal Register and distributed to the SWAs and Federal agencies in official UI “Program Letters” and other memoranda. (UI Program Letters (UIPL) are available on the Internet at the Information Technology Support Center site sponsored by the Department of Labor.) Additional information is also available in the ETA Manual, *UCFE Instructions for Federal Agencies*, last issued in March 1995.

The following summarizes some previous interpretations issued on covered and non-covered employment under UCFE.

UCFE-Covered Federal Service

Department of Agriculture

- Agricultural cooperative employees serving under Federal appointments, including those with the Agriculture Extension Service
- Agricultural Stabilization and Conservation Service (ASC) county and community committee employees
- Employees (but not members) of Agricultural Boards and Committees
- Soil Conservation Service

Department of Commerce

- Census Bureau enumerators
- Commissioned officers of the Coast and Geodetic Survey
- Paid executive directors and employees of Regional Fishery Management Councils

Department of Defense

- Armed Forces non-appropriated fund activities employees
- National Guard and Air National Guard civilian employees

Department of Health and Human Services

- Commissioned officers of the Public Health Service

Department of Interior

- Mammal control agents of the Fish and Wildlife Service

Department of Transportation

- Administrative enrollees of the Maritime Administration
- U.S. Merchant Marine Academy
- Employees in Wage Marine positions

Other miscellaneous UCFE-covered employment

- Administrative employees of members of Congress and congressional committees
- Presidential and Schedule C appointees
- National Credit Union Administration (NCUA)
- Employees of partially-owned Federal instrumentalities – including any Federal intermediate credit banks, banks for cooperatives, or production credit associations in which the Federal government owns capital stock

Not UCFE-Covered/Not Federal Service

Note that when employment is determined not UCFE-covered/not federal service, as in the cases below, States can and may cover these employees under their State UI law. If State QCEW staff is unsure whether one of the categories below should be included as UI-covered, they should contact their UI tax unit.

- Persons paid from Indian tribal funds of the Department of Interior
- Grantees under the Educational Exchange Program of the Department of State
- Peace Corps volunteers and trainees
- Federal Credit Unions
- Federal Intermediate Credit Banks, banks for cooperatives, or production credit associations in which the Federal government owns no capital stock.
- Federal Home Loan Banks
- Federal Land Banks
- Federal National Mortgage Association
- Federal Reserve Banks
- Elective officials in the Executive or Legislative branches
- Persons employed on a temporary basis in cases of fire, storm, earthquake, flood, or other temporary catastrophic emergency
- Enrollees or members of the Youth Conservation Corps
- Participants in the Americorps program administered by the Corporation for National and Community Service
- Participants in nutritional research studies conducted by the Agricultural Research Service of the Department of Agriculture

Chapter 2 – Assigning and Updating the Classification Codes

The QCEW program assigns classification codes to provide as much detail and accuracy to collected data as possible. This involves the use of several coding standards and systems along multiple phases of the collection process. It is necessary that implementation of and compliance with these coding standards be conducted at the state, regional, and national level. Because the QCEW program is an important data source for other statistical programs, there is also a need for continuity of coding systems between BLS programs. This continuity is especially important for aggregated data.

The continuity of the codes themselves is maintained across time within the QCEW program. Changes and updates to codes are taken into account and the data are adjusted in a way that minimizes the impact of the change on the aggregated data as a whole.

----- Contents of Chapter 2 -----

2.1 Coding Standards

2.1.1 State Codes

2.1.2 County Codes

2.1.3 Township Codes

2.1.4 County and Industry Codes for Telework Establishments

2.1.5 Ownership Codes and Organization Types

2.1.6 Industry Codes

2.1.7 Assigning Industry Codes

2.1.8 WebNAICS

2.2 Coordination of Coding with Other BLS Programs

2.3 Changes in Industrial, Ownership, and Area Classification Codes

2.3.1 Types of Code Changes

2.3.2 Timing and Reporting of Code Changes

2.1 Coding Standards

Standards exist for each of the classification codes used in the QCEW program. These standards are defined by program convention and government legislation. The accurate assignment of these codes is critical to continuity of the micro data and consistency of the macro data. Current programmatic standards can be found in the cooperative agreement.

2.1.1 State Codes

The identification of the state submitting the Enhanced Quarterly Unemployment Insurance (EQUI) file is assigned by the standard state processing systems. The Federal Information Processing Standards (FIPS) series is used to report the state code. FIPS State codes and postal service state abbreviations are specified in Appendix C.

2.1.2 County Codes

Each reporting unit must be identified by a FIPS county code based upon the unit's physical location or place of business. FIPS county codes are used to report data on the EQUI file and the state's system. The FIPS county codes are available for download on the US Department of Commerce website [2016 FIPS Codes](#). Updates are made periodically.

The following additional codes should be used to identify the locations of reporting units that cannot be given more specific FIPS county codes:

<u>Code</u>	<u>Description</u>
900	Master Record. Assign county code 900 only to a multi-unit master record. This type of record is the summation of all of its associated reporting units. County code 900 should not be assigned to a single establishment employer (only one establishment with a given UI Account Number in the state). Note that use of this code is preferred but optional; a master record may carry a specific FIPS code (especially if all or most of its subunits are located in one county) or any of the other county equivalent codes shown below.
995	Statewide, locations in more than one county, and no primary county. Assign county code 995 only to reporting establishments that have locations in more than one county, and for which a primary location has not been determined or cannot be assigned by the state. A primary county is the county with the largest share of the total employment of the account. See Primary Counties below in this subsection.

County code 995 should not be assigned to a reporting unit based solely on its mailing address, or based on the corporate headquarters/central office location of the enterprise.

996 **Foreign locations.** Assign only to reporting units whose **physical location** is outside of the United States, Puerto Rico, and the Virgin Islands, but which report to the state agency for UI coverage purposes. County code 996 should not be assigned to a reporting unit based on its mailing address or based on the corporate headquarters/central office location of the enterprise.

998 **Out-of-State locations.** In general, employers must have UI accounts in all states in which they have permanent worksites or in which they have ongoing business operations, such as construction, which lack a fixed worksite. Therefore, employers will typically be required to establish a UI account in every state in which they maintain employment (as defined by state UI laws) on a regular basis.

Assign county code 998 only to a reporting unit where the worksite is located outside of the state to which it is reported for UI purposes, and where this worksite is not required to report in the state in which the worksite is physically located. For example, an employer is based in state A and reports to state A for UI coverage purposes. If this employer has a temporary worksite in state B, and is not required by state UI laws to establish a UI account to report the worksite in state B, then the reporting unit would be assigned county code 998 in state A.

While most out-of- state worksites will be of a temporary nature, there are a few rare cases where an employer may maintain a worksite outside the state in which UI coverage is based that could be classified with county code 998. For example, an employer is based in state A and reports to state A for UI coverage purposes. This employer maintains a training site in state B where the workers are only temporarily assigned for training before the employer permanently assigns them to a worksite in state A.

County code 998 should not be assigned to a reporting unit based solely on its mailing address or based on the corporate headquarters/central office location of the enterprise.

999 **Unknown locations.** Assign to a unit with an unknown or undefined location.

Before assigning code 999 to any unit, states should attempt to obtain the county from the employer. The guidelines in Section 3.3 (Identifying Multi-unit Employers) should be followed for obtaining establishment breakouts from multi-county employers.

Some confusion in assigning county codes may occur with respect to construction companies, utility companies, trucking companies, statewide salespersons, and other "mobile" units. Page 19 of the 2017 North American Industry Classification System (NAICS) Manual states:

Exceptions to the single location exist for physically dispersed operations, such as construction, transportation, and telecommunications. For these activities the individual sites, projects, fields, networks, lines, or systems of such dispersed activities are not normally considered to be establishments. The establishment is represented by those relatively permanent main or branch offices, terminals, stations, and so forth, that are either (1) directly responsible for supervising such activities, or (2) the base from which personnel operate to carry out these activities.

The following rules should be applied in defining the establishment and determining its location:

This type of "mobile" unit should be assigned a county code that corresponds to the location of the main or branch office. Although the establishment's territory may be statewide or spread over several counties, the county code should be consistent with the physical location address of the establishment. The actual reporting of these individuals can vary. The physical location address for salespeople and general contractors working out of their homes is not required. If available, use the home address of the sales or contract person to determine the FIPS county code. If an employer has sales representatives working out of their homes, then the employer should summarize these employees into one reporting unit. The county code would be statewide (995) and the Reporting Unit Description would be "Sales Reps., Statewide."

However, in the case where a construction, logging, drilling, or utility installation expects to be working at one site for more than one year, that site should be treated as a separate establishment and identified by its physical location during the course of the project. The county code assigned to such a long-term project should be consistent with the physical location of the project.

In addition, those employer activities that do not meet either the general definition of an establishment or the 12-month duration criterion may be reported as a county-level record in the county where the activity occurs. States which have been receiving county-level data from firms should continue to request this level of detail or request establishment-level detail (as described in Section 3.1), whichever provides the finer level of detail.

Primary Counties

Some confusion may occur with respect to assigning primary counties in situations where a UI or UCFE account has been identified as a multi-establishment employer, but is unable or unwilling to provide any disaggregated data below a statewide total, or does not meet the size criteria for solicitation of disaggregated data.

States should consider "primary county" as the county with the largest share of the employment in the account, but should only code to primary county when 50% or more of the total employment is in the primary county. States should assign a primary county in cases where disaggregation is not possible from available source, or does not meet the size criteria for solicitation of disaggregated data. See Section 3.5 for examples.

2.1.3 Township Codes

In addition to the FIPS county codes, New England states and New Jersey must identify reporting units by township codes on their micro file and on the EQUI file submitted to the national office. The term township is used to represent areas in New England and New Jersey that are locally referred to as cities and towns.

The following township codes, which are equivalent to the county codes, should be used to identify the locations of reporting units that cannot be given more specific township codes:

<u>Code</u>	<u>Description</u>
900	Master Record. Assign township code 900 only to a multi-unit master record. This type of record is the summation of all of its associated reporting units. Township code 900 should not be assigned to a single establishment employer (only one establishment with a given UI Account Number in the state).
995	Statewide, locations in more than one township, and no primary township. Assign township code 995 only to reporting establishments that have locations in more than one township, and for which a primary location has not been determined or cannot be assigned by the state. This primary location principle should be used to assign county and town codes to an account in cases where 50% or more of the total employment of the account resides in particular town or city.
996	Foreign locations. Assign only to reporting units whose physical location is outside of the United States, Puerto Rico, and the Virgin Islands, but which report to the state agency for UI coverage purposes.
998	Out-of-State locations. In general, employers must have UI accounts in all state in which they have permanent worksites or in which they have ongoing business operations, such as construction, which lack a fixed worksite. Therefore, employers will typically be required to establish a UI account in every state in which they maintain employment (as defined by state UI laws) on a regular basis. Assign township code 998 only to a reporting unit where the worksite is located outside of the state to which it is reported for UI coverage purposes, and where this worksite is not required to report in the state in which the worksite is physically located. For example, an employer is based in state A and reports to state A for UI coverage purposes. If this employer has a temporary worksite in state B, and is not required by state UI laws to establish a UI account to report the worksite in state B, then the reporting unit would be assigned township code 998 in state A.
999	Unknown locations, or no primary township. Assign to a unit with an unknown or undefined location. States in New England as well as New Jersey must notify the

national office through their regional office of any changes to their township code list prior to submitting the affected deliverable EQUI file.

The township code should be paired with an appropriate county code to eliminate any inconsistencies on the EQUI file and the micro file. The following table presents acceptable code combinations in relation to the Multi Establishment Employer Indicator (MEEI) code of each reporting unit.

MEEI	Valid County/Valid Township Combination
1-6	999/999
1-6	995/995
1-6	996/996
1-6	998/998
2	any county code including 900, 995, 996, 998; and township 900 or 999 (CTY and TWN code must match)

2.1.4 County and Industry Codes for Telework Establishments

Telework establishments are worksite locations that are provided by the firm as individual establishments. However, since these establishments represent employees working from home, specific address and industry information may not be provided. Using statewide or unclassified county does not give an accurate picture of the employment, if a valid county can be assigned. A framework for assigning county and NAICS codes to teleworkers has been established and can be applied to these situations.

Teleworking units should be assigned a county and NAICS code that corresponds to the location of the main branch or office, out of which, the teleworking employee is supervised or based. If this information is unavailable, the state should use the “Primary County” principle of assigning the county based on the primary county in the state. NAICS can be assigned following the same principle.

Out-of-state telework establishments are those where the primary location(s) of a firm are located in one State but home-based worker(s) are located in another state. In this case, the state with the home-based establishment in another state should use the county associated with the home-based establishment’s physical location address (PLA), if provided. If no PLA, or adequate information to assign the county is available, county 998 should be applied. NAICS can be assigned following the same principle as in- state locations outlined above.

Guidance for assigning County and NAICS codes for teleworking establishments can be found in QCEW Technical Memorandum [S-13-02](#).

2.1.5 Ownership Codes and Organization Types

Because industry coding may group private sector and government operations together into sectors (other than public administration), it is necessary to report an ownership code in addition to the industry code. The ownership code permits separate or combined publication and analysis of private sector and public sector employment and wages data. The valid one-digit codes for ownership are shown below.

- 1 = Federal government
- 2 = State government
- 3 = Local government
- 5 = Private

Local government includes the governments of counties, townships, parishes, cities, towns, villages, and municipalities. Local government is a political subdivision of a state which has general corporate and police powers as well as the power to levy taxes and spend funds. This ownership can cover a variety of services, education (including school districts), healthcare and social assistance; executive, legislative, and judicial duties; special districts (water, sewage, and other utility services); and other administrative activities.

In addition, several states use organizational type indicator codes for private ownership establishments. (Organizational type is optional for the national office and most states.) This information is often collected on Status Determination Forms to solicit information from private establishments concerning organizational structure, and may be extracted for the EQUI. The code indicates the legal form of organization the establishment used when filing taxes. The organization options are shown below.

- I = Individual
- P = Partnership
- C = Corporation
- O = Other

Indian Tribal Councils

According to Federal law, all Indian Tribal Councils and related establishments should have an ownership code of 3 (Local Government). The law states, as a clarification to the Federal Unemployment Tax Act (FUTA), that Federally-recognized Indian Tribes are to be treated similarly to state and local governments.

The EQUI file and micro file also include a data element called the special indicator (described in Appendix B – Data Element Definitions). States should assign the value "T" (Indian Tribal Council) to the Special Indicator field on records that represent Federally- recognized Indian

Tribal Councils or related establishments. A listing of Federally Recognized tribes can be found on the Bureau of Indian Affairs website.

Establishments not owned by Federally-recognized Indian Tribal Councils but operating in areas under Indian Tribal Council control should have a blank Special Indicator field and must be assigned an ownership code of 5 (Private).

2.1.6 Industry Codes

Initial assignment of a correct industry code is critical for several reasons. It ensures that a significant subgroup of employers (i.e., new units) are classified accurately and that the degree of discontinuity in employment data caused by code changes is reduced.

To enable data to be classified by industry in the micro files, each operating establishment is assigned an industry code on the basis of its primary activity, as outlined in the North American Industry Classification System (NAICS) Manual. Under NAICS, establishments that have similar production processes are classified in the same industry. The conceptual basis is that establishments doing similar things in similar ways should be classified together. This supply-based system allows for the comparison of such things as productivity and labor costs on the basis of inputs and outputs from the production process, rather than on the basis of output alone. In the design of NAICS, special attention was given to new and emerging industries, service industries, and industries engaged in the production of advanced technologies.

NAICS divides the economy into 20 sectors (two-digit), four of which are largely goods-producing and 16 of which are largely service-providing. An additional sector, Sector 99 is used within the QCEW program for unclassified industry. These sectors are broken down further into subsector (three-digit), industry group (four-digit), and five- and six-digit NAICS codes. All reporting units should be classified to the six-digit level of detail. The assignment of industry codes is discussed later in this section.

For the purposes of publication and data dissemination, the QCEW program also defines industries at levels above the official NAICS structure. This includes the grouping of the 21 sectors (the 20 sectors mentioned in the above paragraph plus the unclassified sector) into 13 supersectors, the grouping of the 13 supersectors into two domains (service-providing and goods-producing), and the grouping of the two domains into an all-industry total.

An establishment is classified to an industry when its primary activity meets the definition for that industry. If an establishment performs more than one activity, the industry should be assigned based on the establishment's principal product or group of products produced or distributed, or services rendered. Ideally, the principal good or service should be determined by its relative share of current production costs and capital investment at the establishment. In practice, however, it might be necessary to use other variables such as revenue, shipments, or employment as proxies for measuring significance.

There are some NAICS codes which are, by definition, a combination of activities. In these instances, the NAICS code may not be assigned according to a single primary activity, but according to the combination of activities performed. There are two types of combined activities that are given special attention in NAICS. They are vertical integration and joint production. Vertical integration involves consecutive stages of fabrication or production processes in which the output of one step is the input of the next level. An example of joint production would be an automobile dealer that both sells and repairs cars. See the NAICS manual for more details and examples of vertical integration and joint production.

In general, a single establishment at a physical location engaged in activities that fall into more than one six-digit industry should be assigned only one industry code based on its primary activity. However, in some cases, larger employers may report these units to states separately if they maintain separate payroll and inventory records for these activities. State agencies may treat such special reporting arrangements as separate establishments for record-keeping purposes and for assigning industry codes.

Use of NAICS 999999

NAICS 999999 (unclassified) is a valid temporary code for active units for which information to assign a specific industry is insufficient. It should only be used until the employer can be contacted and the specific NAICS code determined. Since assignment to NAICS 999999 precludes use of the employer's records for industry-specific sampling, such assignment causes an inherent bias for the many studies that draw samples from the Longitudinal Database. The need to recode larger units coded in NAICS 999999 to a known, valid code is critical, particularly since large units are in certainty strata in many samples.

New employers who have not provided sufficient information for the assignment of a six-digit NAICS should be assigned NAICS 999999. States can either participate in the NCA web letter mailing by the BLS approved contractor or print and mail a BLS 3023-NCA (Unclassified Industry) form on a flow basis. If a web response file is received or the NCA form is returned that contains sufficient information to assign a code, the NAICS code should be changed at that time. Establishments not providing sufficient information via the web or on the 3023-NCA form or not responding to NCA requests should be contacted by phone.

Generally, a state's use of NAICS 999999 is considered excessive when it exceeds one percent of total employment in that state. Refer to the current cooperative agreement for specific thresholds.

Private Households

Private household employers are coded in NAICS 814110. Typically, these establishments are private households that employ domestic employees. The code assigned depends on the employer of record. In the case of NAICS 814110, the employer of record is a private household rather than an operating business. Establishments that provide business services to households

are coded according to primary activities. For instance, businesses providing maid services are coded in NAICS 561720, Janitorial Services, while a household that reports a domestic maid on its own account is coded in NAICS 814110. Both types of establishments may provide these services for households. Coding focuses on the employer of record. Establishments coded in NAICS 814110 are excluded from the Annual Refiling Survey although they may be periodically reviewed by the national office.

There is an exception to the rule of coding establishments in NAICS 814110 when a household is the employer of record. Many states have programs geared towards providing funding and assistance to the elderly and/or persons with disabilities to allow the individuals to stay in their homes. Even though the employer of record may be the household, the funding is coming from the state usually by or through an agency. If the state is able to identify that the establishment/household is part of this type of funding arrangement, the establishment should be coded in NAICS *624120-Services for the Elderly and Persons with Disabilities* not NAICS *814110-Private Households*. Often the contact information, UI address and/or mailing address will be that of the agency, which can help identify such units. Additional information can be found in QCEW Technical Memorandum [S-13-04](#).

Coding Master Records in a Multi-Unit Account

States should code master (MEEI 2) records of a multi-unit account with the dominant NAICS code in terms of the employment in the multi as a whole. Exceptions:
Code PEO (Professional Employer Organization) master records in NAICS 561330.
If Headquarters is the dominant industry in terms of employment, code the master records with the NAICS code of the next dominant industry, not NAICS 551114.

Invalid NAICS Codes

States should not assign the following two codes:

<u>NAICS Code</u>	<u>Description</u>
112130	Dual Purpose Cattle Ranching and Farming
541120	Offices of Notaries

Both of these codes are listed in the April 9, 1997 Federal Register as null sets, in other words, invalid for NAICS United States. Any record assigned these codes will continue to be flagged as an error in the standard state systems (EXPO, WIN-202) and the national office systems. Neither code is included in the Annual Refiling Survey (ARS) descriptions and should not be assigned to any establishment.

Reference Sources

There are a number of tools available for assigning NAICS codes to reporting units. The NAICS United States Manual is the reference tool for NAICS classification. With the 2017 Revision, NAICS manuals will no longer be printed. There is an online pdf version available to states. An online tool to search NAICS codes can be found on the Census Bureau NAICS website in addition to the NAICS manual. However, it is not recommended that coders use this site as it does not contain BLS-specific codes. [WebNAICS](#), an online coding tool developed by DASLT and available on the BLS public website contains more activity descriptions (e.g., index items) than the manual, and it provides industry codes for each activity. It also contains the BLS specific codes in the construction industry for example, which the online NAICS manual does not have because the residential/non-residential distinction is not used by the Census Bureau. Finally, updates to the program covering new activities and coding interpretations are provided periodically.

NAICS Coding Interpretations

In any large-scale coding operation, coders will come across some employers that are difficult to classify. The Industry Coding Team (ICT) was established as an advisory body with the purpose of providing guidance on industry coding matters in the QCEW program. It is made up of national and regional office BLS staff and state staff and can be reached via email at 202QA@BLS.GOV

Training

The national office and the office of field operations periodically provides introductory and advanced NAICS training, and an online NAICS training materials are available for new coders.

2.1.7 Assigning Industry Codes

The assignment of industry codes is the process of identifying the establishment's primary activity. Some of the confusion about industry coding is caused by the technical nature of the industries and the descriptive language associated with these industries. The coding process is further complicated by the industrial and technological change that occurs between revisions of the industry codes. Using the following steps will reduce some of the difficulties associated with assigning the proper industry code.

Step 1: Research the Case

The coder should develop a basic understanding of the primary activity or service involved to ensure accurate coding. The terminology used by the employer can sometimes be confusing or misleading. It is up to the coder to determine whether the terms used by the employer are

comparable to the industry coding manual terminologies; thus, personal knowledge and coding experience are valuable.

Step 2: Identify Possible NAICS Codes

The coder should review all industry coding reference sources (e.g., NAICS online Manual, and the [WebNAICS](#)) to determine possible NAICS codes. The coder must determine whether or not the employer-supplied information is sufficient to assign a code. If not, the employer should be contacted.

Step 3: Select an Appropriate NAICS Code

The coder should examine all related industry descriptions to determine the most appropriate one. Note that NAICS classifies establishments based on their primary activity rather than just on the products produced. The conceptual basis of NAICS is that establishments doing similar things in similar ways are included in the same industry.

Step 4: Top-Down Approach for Difficult Cases

When the coding decision is not clear cut, narrow your choices by first determining an appropriate NAICS sector, subsector, industry group, and eliminating unacceptable 6-digit NAICS codes until you find a code that appears correct.

If the industry information is inadequate or insufficient at any time during the coding process, the state should contact the employer. Large units, in particular, should be called to clarify information. If the information is complete but it is still difficult to determine the correct NAICS, the state should request coding assistance through the regional office or the Industry Coding Team.

To eliminate the effect of seasonal or other short-term fluctuations, a 12-month period should be used as the basis for determining the principal activity when assigning industry codes.

An establishment entering business for the first time should be classified according to the anticipated primary activity indicated by the employer on the initial status determination form.

2.1.8 WebNAICS

What is WebNAICS?

WebNAICS is a public web page version of the NAICS manual that was introduced with the 2017 NAICS manual. Deployment via the public website enables the software to reach a larger audience and assists in more consistent use of NAICS codes as implemented at BLS.

WebNAICS is a resource for QCEW data users. WebNAICS provides access to both NAICS 2012 and NAICS 2017. It enables users to conduct searches by index items, short titles, full descriptions, or all of those options combined to get matching six-digit NAICS classifications. The search feature allows users to search by NAICS code digits. The search results contain the NAICS full title and description, cross-reference information, and associated indexes. Users can sort results alphabetically or by NAICS digits.

Users can download .csv files containing NAICS indexes, titles and descriptions, cross-references, and illustrative examples. The WebNAICS page and these .csv files can be provided to Unemployment Insurance (UI) Tax departments that need BLS-specific NAICS codes.

Link to WebNAICS:

http://www.bls.gov/cew/bls_naics/bls_naics_app.htm

2.2 Coordination of Coding with Other BLS Programs

General Coordination

QCEW reporting units which also appear in other BLS programs, such as Current Employment Statistics (CES), Occupational Employment Statistics (OES), and Occupational Safety and Health Statistics (OSHS) should carry the same industry and geographical codes in all programs. The state should make every effort to assure that coding changes in one program are reflected in the other programs as well while being mindful of CIPSEA guidelines. The QCEW staff should serve as the central unit for resolving coding differences.

2.3 Changes in Industrial, Ownership, and Area Classification Codes

The industry, ownership, or county code (or township code for **New England states as well as New Jersey**) of a reporting unit, should be changed if the state agency has received information that the code is incorrect because of (a) a coding error, or (b) a permanent change in the principal activity, ownership, or location. A permanent change is considered to be one that is expected to continue for at least the next 12 months. If the change is expected to be of shorter duration, the code should not be changed to correspond with the new activity, ownership, or location. For example, an employer who intermittently engages in two different activities classifiable under different codes should not be reclassified from one activity to the other, if past experience indicates that these changes are only temporary. The unit should be classified according to the activity that predominates or that uses the greatest share of production costs over the year as a whole.

2.3.1 Types of Code Changes

The use of employment and wage statistics as indicators of economic trends may be affected by changing the industry, ownership, or area codes of reporting units, which causes breaks in the levels of industries involved. Therefore, special handling of the data for reclassified reporting units is required. When the industry, ownership, or area code of a reporting unit is changed, the code change should be considered as falling into one of the following three major categories:

Noneconomic Code Changes

This category includes those code changes that are not due to changes in the economic picture. These are "structural" code changes, which are the result of changes in the coding structure, and corrections to codes that previously were assigned incorrectly. This category includes code changes for which it cannot be determined whether the previous code was incorrectly assigned. Also included in this category are code changes for reporting units which have shifted gradually from one primary activity, ownership, or location to another; or which are assumed to have shifted gradually because of lack of sufficient information to justify classification as economic code changes.

Noneconomic code changes may also result from the receipt of a breakout or collapse of a multi-unit account that had previously not been included on the micro files. An exception to this rule occurs when the industry and/or the county code for a multi-unit account were originally coded as unclassified (NAICS 999999, county 999, township 999). See the procedures below on handling changes which involve unclassified codes.

Economic Code Changes

This category includes code changes of reporting units that are known to have converted completely from one industrial activity, ownership, or location to another. A unit may be considered as having converted completely if there was a substantially complete shutdown of production between the old and the new activities, ownerships, or locations which took place in less than a month. To be considered an economic code change, the conversion must be identified in time to report the correct new code(s) in a timely manner – when the conversion occurred. Also, the economic change must not reflect a gradual shift.

Change from Unclassified

The assignment of a specific industry, county code, or township code to a unit for which data previously have been reported as "unclassified" is not considered a noneconomic code change, but is considered a separate type of code change. Note that for county and township code, a change to a specific code from any of the county or township equivalent codes (900-999) should be treated as a change from unclassified.

2.3.2 Timing and Reporting of Code Changes

When an industry, ownership, county code, or township code change results in a significant change in employment for an industry/ownership/county/township combination, the state should follow the procedures described in Chapter 11 that allow the system to place the record on the Code Change Supplement (CCS) if the code change is noneconomic. If it is an economic code change, assign an appropriate comment code. Comment codes are discussed in Section 9.6 and in Appendix I.

Reporting requirements for the specific types of code changes are described below.

Noneconomic Code Changes

Noneconomic code changes, except for those resulting from structural changes in coding manuals, should be made effective only with data for the beginning of a calendar year. This may require corrections back to the first quarter, particularly when the CCS is still open.

Partial successor situations (where part of one establishment's employment transfers to another establishment) are handled as follows: If the transfer does not change the industry code of the entire successor unit, it should not be treated as a noneconomic code change. Though these types of transfers may cause a fluctuation in employment between macro cells, the overall operation of the two units involved does not change. Therefore, in most cases, employment changes that are a result of partial successors do not belong on the CCS.

In some cases, in conjunction with a national office recommendation, data will be corrected back to first quarter even though the CCS may have been locked. For example, if data for a large firm were mistakenly coded to a new county or industry in first quarter, moving the data back to their correct coding in the subsequent year would disrupt the historical flow of both cells. In such a case, the data would be recoded to their proper cell for the entire reference year regardless of when the error was discovered.

Noneconomic code changes made as a result of receiving a breakout for a multi-unit account that had not been broken out previously on the micro files should be made effective with the first quarter's data. Making these changes to first quarter data is important to avoid unrealistic fluctuations in data for the industries and areas involved. Section 5.5 describes this further. Chapter 11 explains code change concepts, rules, and BLS processing.

In the case of future structural changes in coding manuals, the national office will issue specific instructions.

Economic Code Changes

For economic code changes, the time of the code change must be identifiable and not a gradual shift. Economic code changes (ownership, NAICS, or county/town) are accepted in any open quarter, current or previous.

Reporting units with economic code changes should be assigned an appropriate comment code. This information should be kept on file so that units involved may be identified in the event that studies of their effect on levels and trends of the data are undertaken.

Changes from Unclassified

Changes from unclassified industry, county, or township codes (industry code 999999 or county/township 900-999) to a specific code should be made immediately. If the data are significant and will affect published levels, back quarter corrections should be made to place the data in their correct cell for all of the reference year. If these changes are identified in the ARS, they should not be handled as noneconomic code changes identified by Response Code 46 (CCS update) or 50 (Code change from non-ARS source). They should be assigned Response Code 41 (Reviewed, no CCS changes) to exclude them from the CCS. The following table summarizes the information pertaining to the code changes.

Reason for change	Type of code change	When code change is to be made	Should be on CCS?
Complete conversion (NAICS/Own)	Economic code change	As soon as conversion occurs	No
Gradual conversion (NAICS/Own)	Noneconomic code change	First quarter	Yes
Noneconomic code change (except change from unclassified code – NAICS 999999)	Noneconomic code change	First quarter	Yes
Change from unclassified code (999999 for NAICS, 900-999 for county and township)	Change from unclassified	As soon as possible	No
County or township code miscoded (except change from 900-999)	Noneconomic code change	First quarter	Yes
Changes in county or township of reporting unit	Economic code change	As soon as change occurs	No

Chapter 3 – Special Processing for Multi-Unit Employers

Employment and wage data in the QCEW program are aggregated by type of ownership, by industry code (see Appendix P), and by county. To report data accurately at these levels for all establishments, states must make special provisions for employers who operate more than one establishment under one employer UI Account Number. Disaggregated reporting provides a more detailed industry and location information in an establishment-based database.

States should solicit multi-establishment employers to submit data for their individual establishments (worksites) on a Multiple Worksite Report (MWR). States maintain the disaggregated data on the QCEW state files and report it to BLS on the Enhanced Quarterly Unemployment Insurance (EQUI) file. See Appendix A for the flowchart.

----- Contents of Chapter 3 -----

- 3.1 Requirements for Disaggregating Multi-unit Employers
- 3.2 Assigning the MEEI Code
- 3.3 Identifying Multi-unit Employers
- 3.4 Using the Multiple Worksite Report
 - 3.4.1 Printing MWR Forms
 - 3.4.1.1 Printing MWR Forms Locally
 - 3.4.1.2 Centralized Printing of MWR Forms (MWR Print)
 - 3.4.2 Solicitation and Informed Consent Letters
 - 3.4.3 Review and Processing of MWR Data
 - 3.4.4 Delinquent MWR Reporters
- 3.5 When Quarterly MWRs Are Unavailable
- 3.6 Report of Federal Employment and Wages

3.1 Requirements for Disaggregating Multi-unit Employers

In general, employment and wage data and identification information should be collected from multi-establishment employers at the worksite (store, plant, etc.) level. However, if different economic activities are being performed at one establishment, each activity should be reported as a separate establishment. As stated in the "Definition of an Establishment" section of the NAICS Manual:

"In such cases, each activity is treated as a separate establishment provided:

- (1) no one industry description in the classification includes such combined activities;
- (2) separate reports can be prepared on the number of employees, their wages and salaries, sales or receipts, and expenses; and
- (3) employment and output are significant for both activities."

An employer who has more than one establishment reporting under the same UI account number within the state and has employment of 10 or more in the combined secondary establishments qualifies for disaggregation as a multi-establishment employer. States have the option to disaggregate multi-establishment employers that have fewer than 10 employees in the secondary establishments, if sufficient resources are available.

The primary establishment is defined as the establishment with the most employment. Where employment is equal across all of the establishments, one establishment is designated as the primary. All other establishments are secondary establishments. Under this definition, the industry code and county codes of the secondary establishments are not factors in the determination of the multi-status. Once the criterion of 10 employees in secondary establishments is met, each worksite should be reported separately, regardless of the size of each worksite.

For clarification, some examples follow.

Example #1: Multi-establishment employer who meets the employment criterion

	Establishment	NAICS	County	Employment
Primary	A	453110	011	100
Secondary	B	453110	013	40
Secondary	C	453110	015	8

Total Secondary = 48 Employees

Multi to be disaggregated? YES

Establishment A is the primary establishment. The sum of employment in secondary establishments is 48 (40 in establishment B plus 8 in establishment C). Each establishment should be reported separately with its proper industry code, county code, other business-identifying information, employment, and wages.

Example #2: Multi-establishment employer who meets the employment criterion

	Establishment	NAICS	County	Employment
Primary	A	453210	011	6
Secondary	B	453210	011	6
Secondary	C	453220	013	6
Secondary	D	453210	011	6

Total Secondary = 18 Employees

Multi to be disaggregated? YES

Establishment A has been designated as the primary establishment even though its employment is the same as that of the other establishments. The sum of the employment in the secondary establishments is 18. Since the sum of the employment in the secondary establishments is 10 or more, each establishment should be treated as a worksite with its proper industry code and county code and reported separately, regardless of the size of each worksite.

Example #3: Multi-establishment employer who meets the employment criterion

	Establishment	NAICS	County	Employment
Primary	A	453910	013	43
Secondary	B	453910	013	5
Secondary	C	453910	013	5

Total Secondary = 10 Employees

Multi to be disaggregated? YES

Establishment A is the primary establishment. The sum of the employment in the secondary establishments is 10 (5 in establishment B plus 5 in establishment C). Since the sum of the employment in the secondary establishments is 10 or more, each establishment should be treated as a worksite with its proper industry code and county code and reported separately, regardless of the size of each worksite.

Example #4: Multi-establishment employer who does not meet the employment criterion

	Establishment	NAICS	County	Employment
Primary	A	453220	011	100
Secondary	B	453310	013	3
Secondary	C	453310	015	3

Total Secondary = 6 Employees

Multi to be disaggregated? NO

Establishment A is the primary establishment. The sum of the employment in the secondary establishments is 6 (3 in establishment B plus 3 in establishment C). Since this sum is less than 10, the state is not required to solicit this employer. If the state elects to maintain this as a single unit, all activity should be coded in NAICS 453220 in County 011 with a Multi Establishment Employer Indicator (MEEI) code of 6 (Known multi-establishment employer reporting as a single unit and not solicited for disaggregation because of small employment (< 10) in all secondary establishments combined.)

Dispersed Operations, No Fixed Worksites

In industries characterized by dispersed operations, such as construction, transportation, and communications, states should follow the guidelines provided in the 2017 NAICS Manual to determine which particular work locations should be treated as separate establishments for data collection and reporting purposes:

"For these activities, the individual sites, projects, fields, networks, lines or systems of such dispersed activities are not normally considered to be establishments. The establishment is represented by those relatively permanent main or branch offices, terminals, stations, and so forth, that are either (1) directly responsible for supervising such activities, or (2) the base from which personnel operate to carry out these activities."

Consequently, employment and wage data for workers in these industries should be collected for the point of supervision or the base from which these workers operate.

In addition, states have identified employers in certain other industries that typically have no fixed worksites. (These industries are an exception to worksite reporting.) Employment and wage data and identification information for these employers can therefore be collected on a county (town for New England states and New Jersey) and industry basis.

Industry	NAICS
Drilling Oil and Gas Wells	213111
Support Activities for Oil and Gas Operations	213112
Logging	113310

On the MWRs for the industries noted in the above table, the worksite descriptions should state that the employment and wages reported include data for the entire county, such as:

"TAYLOR COUNTY OIL EXPLORATION,"

"HOWARD COUNTY OIL EXPLORATION,"

"SMITH COUNTY LOGGING."

There are other examples of work situations not considered to have fixed worksites. This includes sales representatives working out of their homes, which should be reported as one worksite with a Reporting Unit Description (RUD) of "sales representatives-statewide." The County code for this unit should be 995 (Statewide).

Data for construction industries have also historically been collected at the industry code and county level. States should continue this practice as long as employers are willing to provide the necessary data. For those employers who are unwilling, the establishment concept outlined in this subsection may be used.

3.2 Assigning the MEEI Code

The Multi-Establishment Employer Indicator (MEEI) codes specify the multi-unit status of each reporting unit. These codes must be carried on states' files and reported on the Enhanced Quarterly Unemployment Insurance (EQUI) file. The MEEI codes are necessary to identify and process records properly. The MEEI code is a quarterly field and relates to the reporting for that quarter. Each record must be assigned one of the following MEEI codes:

MEEI 1: Assign to an employer who operates at one worksite. Only one establishment for this employer will appear on the file with a unique UI Account Number and a Reporting Unit Number (RUN) of 00000.

MEEI 2: Assign to a record which is a multi-unit master (parent) record. That is, a record which is the summation of all of its composite reporting units (subunits) should be assigned an MEEI of "2." The RUN for this type of record must be 00000.

MEEI 3: Assign to the individual subunit (worksite) records for each multi-unit employer. This MEEI code represents a true one-establishment worksite. Each subunit record will have the same UI Account Number as its master unit record but should carry a different RUN. For example, if an employer within a state has four establishments and each establishment has six employees, an MEEI of "2" and an RUN 00000 would be assigned to the master. An MEEI of "3" would be assigned to each of the four subunits. The subunits would carry different RUNs (for example, 00001, 00002, 00003, and 00004).

MEEI 4: Assign to an employer who has been identified as a multi-establishment employer, but is unable or unwilling to provide any breakouts below a statewide total and the state is unable to locate information to estimate a breakout for the employer. Assign RUN 00000 to all units with MEEI 4.

MEEI 5: Assign to a record representing a **combination** of subunit establishments of a multi-establishment employer but reported as one subunit. The combined record should be assigned a unique RUN greater than 00000. (An employer who provides county-level data, for example, should not be coded as MEEI 4, but rather as a 5.)

MEEI 6: Assign to a multi-unit employer who does not meet the size criterion for soliciting disaggregated data. For example, if an employer has three establishments with employment levels of 60, 3, and 3, then the reporting unit would be assigned an MEEI of "6" – multi-establishment employer not solicited because the secondary employment is less than 10 (see Section 3.1). The unit would be treated as a single unit and report the aggregate under the primary industry and county. This unit should carry RUN 00000.

Because all records coded as MEEI of 4, 5, or 6 represent an aggregation of establishments, the QCEW staff should provide (at least for those units with an MEEI of 5) a description of that aggregation in the RUD field.

The following chart summarizes the proper combinations of MEEI codes and RUNs:

Unit Type	MEEI	Reporting Unit Number
Single Establishment	1	00000
Multi-establishment employer master record (subunit data available)	2	00000
Multi-subunit (worksite or establishment level)	3	00001-99998*
Multi-establishment employer reporting as a single (disaggregated data not reported)	4	00000
Multi-subunit comprised of more than one establishment or worksite	5	00001-99998*
Multi not solicited because of secondary worksites' size and, thus, remaining a single unit	6	00000

* The Reporting Unit Number must be numeric, containing a value from 00000 to 99998 (See Appendix B.) In obtaining RUNs for new worksites, states are to assign the next available RUN to a new worksite. States should assign the next available number (in sequence) and are **not to reuse RUNs**. States should check for new and invalid RUNs. Invalid RUNs include RUNs that are duplicates or discontinued.

3.3 Identifying Multi-unit Employers

Identifying multi-unit firms can be difficult. Valuable sources of information for detecting multi-unit accounts are described below.

Annual Refiling Survey

The Annual Refiling Survey (ARS), serves as one of the primary means of identifying new multi-establishment employers as well as the instrument to collect the physical location addresses and business activities of single and multi-unit employers. For ARS purposes, all units coded as MEEI 1, 4, and 6 are considered "singles". The ARS collection instrument for singles is ARS Web, which is administered by the BLS Internet Data Collection Facility (IDCF). All

units coded as MEEI 2 are “multis”. The ARS collection instrument for multis is NVM Web, which is also administered by the IDCF.

The ARS Web questionnaire (form BLS 3023-NVS) includes a section in which employers are asked to identify any instances where the surveyed UI includes employment and wage data for more than one physical location in the state. For each additional physical location, beyond the surveyed establishment, the respondent is asked for the trade name, physical location address (PLA), county, business activity, reporting unit description (RUD), and employment. States then update their systems with the additional site information provided by the national office to states via EUSWeb. (See Chapter 6 for a description of ARS Web.)

Quarterly Contribution Report Forms

Some states include a question on the quarterly contribution report (QCR) that asks directly whether the employer has more than one establishment. In other states, the form requests changes in business activity during the last quarter. Even if such a question is not included, a sharp increase in reported employment over the previous quarter's employment should indicate a need for additional research. This research may identify the opening of new establishments or the addition of acquired reporting units (see Chapter 5). For example, the following table shows a sharp increase in employment.

Example 1:

Establishment	2020/1	2020/2	2020/3
A	25	25	135

Establishment A increased employment from 25 in 2020/2 to 135 in 2020/3. Further research reveals that establishment A opened a second establishment in 2020/3 under the same UI. This establishment now meets the employment criteria and should be disaggregated as shown below.

Establishment	2020/1	2020/2	2020/3
A	25	25	25
B	0	0	110

Example 2:

Here is an example of two single UI accounts (establishments A & B) merging their reporting into one establishment (C). The merged reported establishment has more than 10 employees and we know that this is not a true single, because it represents two establishments, so this new firm should be sent an MWR form to collect data for both worksites.

Establishment	2020/1	2020/2	2020/3
A	25	25	0
B	15	15	0

C	0	0	40
---	---	---	----

Employer's Wage Record

The wage record is also known in some states as the wage list, wage report, or the payroll report. State UI offices require the employer to submit these data along with the quarterly contributions report. The wage record lists the total quarterly wages for each employee, and their respective Social Security Number and name. Wage records are a useful tool for researching suspected multi-unit accounts. Instructions for using the wage record in obtaining breakouts from multi-unit employers are provided later in this chapter.

Other Statistical Surveys

Information collected in other surveys may also assist state staff in identifying firms with more than one establishment. Surveys which may supplement the available information include the following: Current Employment Statistics (CES), Occupational Employment Statistics (OES), and the Occupational Safety and Health (OSH) Survey. States should develop a procedure by which information obtained in other surveys regarding multi-unit employers can be made available routinely to the QCEW staff. The state QCEW staff must independently validate this information to avoid violating the Confidential Information Protection and Statistical Efficiency Act (CIPSEA).

Other Sources

Media and other local news sources, UI field offices, and business directories may be used to validate multi-unit detail on the state system.

3.4 Using the Multiple Worksite Report

After a UI account has been identified as a multi-establishment employer, state staff must arrange for the employer to provide quarterly breakouts of employment and wages and business identification information for each worksite. By obtaining these breakouts, the state can ensure detailed and accurate data in the state system and the EQUI file.

The importance of complete and accurate breakouts of multi-establishment employer data cannot be over-emphasized. State personnel should stress the importance of disaggregated data in soliciting breakouts and in all communications with respondents. State personnel should remind respondents that these data are critical to the preparation of accurate reports on the economic conditions within the state. Furthermore, the data are used to ensure an equitable distribution of federal funds through grant programs that use county economic indicators as a basis for allocations, and for specific sample surveys. With the move to geocoded data, the emphasis on worksite level reporting has also increased significantly.

If known multi-employer records show no indication of establishment-level data, state personnel should point out the value of establishment reporting to the respondent and offer assistance to overcome reporting problems. States should encourage respondents to report online via MWR web. Reporting MWR data electronically to the EDI (Electronic Data Interchange) Center for large accounts can also reduce employer burden. (See Chapter 4, Multiple Worksite Central Reporting.) Firms providing computer print outs in lieu of the MWR form is acceptable. This is the least cost-effective method of collecting the data, so it should be used only when the firm refuses to report via MWR Web, EDIC, or using the MWR form.

The MWR is a standardized OMB approved form used to collect employment and wage data as well as physical location addresses and business identification information for each establishment under a multi-unit employer. The data collected is used to ensure proper industrial and geographic detail. See examples online at <https://www.bls.gov/cew/mwrforms.htm>.

The most cost effective method for printing and mailing MWR forms is by utilizing the MWR print contractor, which is discussed in detail in later in this chapter. The standardized state systems provide the capability to print the MWR forms in states, using national-office supplied form templates. Programmable printers that merge and print the form templates with the State and employer identification information are generally used. Also, EXPO Service Center states can print smaller batches of MWR forms (typically for follow-up purposes).

The employer mailing address fields are formatted as described in Appendix B – Data Element Definitions, since this will minimize postal delivery problems. Addresses should be entered according to the latest USPS guidelines available here:
<https://pe.usps.com/text/pub28/welcome.htm>

The entire form mailing address of the employer (in Section 2 of the form), including the city, state, and Zip Code will be printed with all capital letters. Instead of a comma and a blank to separate the City and State, only one blank space is used. Between the state and Zip Code, two blank spaces are used. An example of a properly printed mailing city and state address is:

ANYTOWN CA 12345-6789

The multiple worksite reports are paper forms with worksite information sent to respondents every quarter by either the state or the print contractor. A return envelope and an MWR letter is sent with the form to address handling and information for new or continuing MWR reporters and varies also for mandatory and voluntary states. (See Appendix P). If a first mailing for the quarter is not returned, a second follow-up mailing is sent. Respondents are asked to enter their monthly employment and quarterly wage totals. Completed and returned MWRs are processed by the state based on solicitation method and response method. Note that the total employment and wages on the MWR should match the total employment and wages on the QCR.

Alternative solicitation and response options have been introduced to reduce respondent and state processing burden. These methods include MWR print contract, MWR Web, and states may also refer large multi-state employers to the EDI Center (The booklet for employers [Electronic Data Reporting, April 2011](#) describes this process further).

Each quarter, the employer is prompted to provide monthly employment and total quarterly wages for each worksite identified on the MWR. They may also verify the additional information such as the trade name, reporting unit description, and physical location address for each worksite. The reporting unit number (RUN) is preprinted on the form in the Office Use column of the Worksites section (Section 3). The information on the MWR originates from data maintained on the state system. Specific instructions are provided on the form as to how new, inactive, closed, or sold units are treated.

National Office Form Printing Inputs

The state contact information is listed on the state contact information spreadsheet and is stored on QCOM. The state contact information spreadsheet also includes: (1) the Authorization Statement to be printed by each state onto their MWR forms (Item 1, first page of the MWR form), (2) the state QCR name and number references to be printed onto their MWR form, (3) the MWR Return Address and phone/fax number(s), and (4) MWR Contact for Public Website. Any changes to these items must be updated on the state contact information spreadsheet and notification sent to MWRWeb@bls.gov. The QCR name and number reference information is printed in Item 1 of the MWR form (after the Authorization Statement text). The QCR number reference is also printed at the bottom left of the form below the last worksite box.

Once updates are received, the information is forwarded by national office to the state system developers and the MWR print contractor for update. This information is updated on the BLS public website, the MWR Web collection site, and the MWR Print Contract forms as needed.

This input information is requested and maintained by national office on a flow basis so that the most current information is printed onto the MWR forms, the BLS public website, and the MWR Web collection site for each state.

Authorization Text (Voluntary)

States that do not mandate completion of the MWR form **MUST** use the voluntary authorization text on the form (as shown below):

"This report is authorized by law, 29 U.S.C. 2. Your voluntary cooperation is needed to make the results of this survey complete, accurate, and timely."

3.4.1 Printing MWR Forms

There are two ways for states to print their MWR forms, which are mailed to respondents.. States can print the forms themselves, locally. This is covered in [Section 3.4.1.1](#) Alternatively, states can arrange through the national office to have their forms printed, mailed, and processed

by a contractor. This process is called the *MWR Print Project* or simply *MWR Print*; it is covered in [Section 3.4.1.2](#).

The first and second mailing of most MWR paper forms provides an MWR Web ID and password, which the respondent can use to login to the website if they choose to report via the web rather than on paper. Once MWR data are submitted using the web, paper forms will no longer be sent. Respondents are sent an email reminder each quarter when data collection has begun. The benefits of using MWR Web include printing and postage savings and increased timeliness of data collection. MWR Web respondents will be able to:

- view all of their worksites on a single page
- report multiple UIs under one MWR Web account
- add/remove/update UIs or worksites
- address large employment and wage changes (system flags and questions respondent inputs)
- apply new unit NAICS as suggested based on other worksites

Here is an example of Web ID and password sent to respondents on paper MWR forms.



MWR Web is covered in Chapter 4, Multiple Worksite Central Reporting.

3.4.1.1 Printing MWR Forms Locally

The state systems will print the physical location address of each subunit record in the worksites section of the MWR form, along with the trade or legal name and the reporting unit description if they are present. In the most common situation, the subunit record represents a true one-establishment worksite and the record has a physical location address.

If the Street Address Line 1 and City are blank on the physical location address block of the worksite (MEEI 3, 5), the state systems will print the message “*** Address Unknown -- Please Provide ***” in the space reserved for the Street Address in the Worksite box on the MWR form.

If the FIPS County code for the worksite (MEEI 3, 5) is greater than 900, the state systems will print the following text in the space reserved for the Street Address in the Worksite box on the MWR form.

For County 995: MANY LOCATIONS OR STATEWIDE

For County 996: PHYSICAL LOCATION(S) OUTSIDE OF U.S.

For County 998: PHYSICAL LOCATION(S) OUTSIDE OF STATEFor County 999: ADDRESS UNKNOWN

The reporting unit description, if present on the worksite record, will print on the MWR form. The employer is prompted to provide a physical location address (PLA) for the unit based on the reporting unit description. If the employer does not provide the PLA, the state should contact the respondent to obtain the physical location address. If physical location addresses are collected by the EDI Center, refer to chapter 4.

If the record represents an aggregated subunit (MEEI 5) record and a physical location address is available for each of the worksites comprising that record, the state should put the address of the largest establishment for that (aggregated) subunit onto the record so it will print on the MWR. Use the reporting unit description to describe the aggregation of establishments so that employment and wage data are reported properly. (The employer should be familiar with the aggregation since it was the employer who informed the state of the unavailability of worksite-level data and the need to aggregate data for some combination of worksites.)

If the record represents an aggregated subunit (MEEI 5) and a physical location address is available for only one of the worksites comprising that subunit record, that address should be used even though the worksite may not be the largest. Again, the reporting unit description should be used to describe the aggregation.

In converting from county level reporting to establishment level reporting, states should collect worksite identification information so it can be pre-printed on the MWR. If a pre-existing multi establishment employer has not provided worksite identification information prior to being solicited for worksite level data, the worksite boxes on the MWR form would preferably be blank and the reporting unit descriptions would not identify the county. Using only the county name has been shown to mislead employers into submitting county level data even though establishment-level data are desired. Of course, this practice is acceptable for those industries identified in Section 3.1 where county and industry code reporting is appropriate.

States should retain copies of completed MWRs for eight quarters: the quarter most recently mailed and seven prior quarters. For example, when MWR forms for 2020/1 are mailed in late March, there should be seven prior quarters of forms on hand, 2019/4 through 2018/2, inclusive. At the end of June 2020, the forms for 2018/2 can be destroyed (because of the confidential nature of the data) when the forms for 2020/2 are mailed.

MWR forms should be kept in such a manner that state staff can retrieve them with reasonable ease, for example, by batch number.

3.4.1.2 Centralized Printing of MWR Forms (MWR Print)

States are encouraged to participate in the MWR print contract (also referred to as *MWR Print Project* or simply *MWR Print*). The print contract designates a contractor to handle printing, mailing, receiving, sorting, and scanning of the MWR forms. The employment and wage data from the forms are scanned and a data file is created for the states to load to the state systems. The image of the form is also scanned and provided to the states. Participation in the MWR Print Project is voluntary.

MWR Print Project Processing and Flow

- Twice each quarter, once for an initial mailing and once for a second/follow-up mailing to non-respondents, participating states use their standardized QCEW processing system to provide the national office with a print file.
 - o The initial print file is due from states to the national office about three weeks before the end of the reference quarter.
 - o The second mail file is due about five weeks after the end of the reference quarter. These mail files include all the information that the contractor needs to print and mail the MWR forms.
- Using each state's print file, the contractor prints the MWR forms and mails them to the address that is in the state's system, which the state provided on the print file. Included with each mailing is a return, postage-paid envelope addressed to the contractor.
 - o The first mailing is about a week before the end of the reference quarter.
 - o The second (follow-up) mailing is about seven weeks after the end of the reference quarter.
- The contractor processes the completed, returned paper MWR forms by scanning them two different ways.
 - o The worksite employment and wage data written on the forms by the respondent are scanned into a .txt file.
 - o Additionally, the contractor separates each form into one of two categories, each of which is scanned into a distinct .pdf file. One category of .pdf files (known as Category 1) includes the returned forms on which the respondent entered only their monthly employment and quarterly wage information. The other category of .pdf file (known as Category 2) includes all other returned forms, which include any additional, respondent added information besides employment and wages of continuous reporting units, written on the form by the respondent.
- Each week, the national office provides three files to the state.
 - o The .txt file of the employment and wage data for each reporting unit, which the state loads into their state system.
 - o A .pdf file of the form images that had nothing written on them by the respondent except for their employment and wage data for continuous reporting units. (Generally, states do not do much with this .pdf file, but it can be useful if the state wants to check an unusual value on the loadable .txt file.)

- A second .pdf file that includes the form images where the respondent included any information beyond the employment and wages of continuous reporting units. For example, this file would include the form images where the respondent provided a corrected address for one of their reporting units or noted that a reporting unit has closed. It is important that states review this .pdf file carefully and make any necessary changes in their state system.
- In addition to completed or annotated MWR forms, sometimes the respondent will return other items (a listing or a letter, for example) to the contractor. These materials are known as *white mail* or *Category 3 forms*. Each week, the contractor sends a package of any such white mail that they receive from respondents to the state, where the state can process it as necessary.

The QCEW page on StateWeb (<http://199.221.111.170/program/ES202/QCEWmain.htm>) includes a calendar of all the MWR Print processing activities and due dates, which the national office posts each year and updates as necessary

MWR Print Forms

Because they are designed to be scanned into loadable .txt files of collected employment and wage data, the MWR forms used in the MWR Print Project look somewhat different than MWR forms that states print. The MWR Print forms that the contractor prints and mails include small boxes into which the respondent is to write each digit of their reported employment and wages.

EXHIBIT 3A shows an example of a Category 1 MWR Print form. This example shows a case where the respondent did not write anything on the form besides employment and wages of continuous reporting units. From such forms, the employment and wages will be read by the contractor and provided to the state on the loadable .txt file. Additionally, the “picture” of this form will be provided to the state in a .pdf file of forms that specifically included only employment and wages of continuous reporting units.

EXHIBIT 3B shows an example of a Category 2 MWR Print form where, in addition to employment and wages, the respondent wrote a note on the form. From such forms, the employment and wages will be read by the contractor and provided to the state on the loadable .txt file. Additionally, the “picture” of this form will be provided to the state in a .pdf file of forms that specifically includes information on the form in addition to the employment and wages of continuous subunits.

EXHIBIT 3A Example MWR Print Form with Only Employment and Wages

UTANA DEPT OF LABOR
123 MAIN STREET
UTANACITY, UTANA 12345-6789
123-456-7890

Multiple Worksite Report - BLS 3020
Form Approved, O.M.B. No. 1220-0134
Expiration Date 05/31/2016
In Cooperation with the U.S. Department of Labor

UTANA DEPT OF LABOR

Please fill out this form with blue or black ink.

1

This report is mandatory under UTANA LAW 123.456.789.0 07, 8-76-103(3)(a)(III), and 8-81-101, and is authorized by law, 29 U.S.C. 2. Your cooperation is needed to make the results of this survey complete, accurate, and timely. The totals on this form must match the corresponding totals on your Unemployment Insurance Tax Report (Form 123 1).

2

QUARTERLY REPORT INFORMATION

ABC CORPORATION
JANE SMITH
123 MAIN STREET
SOMECITY, UA 12345-6789

U.I. NUMBER : 1234567890
QUARTER ENDING : MARCH 31, 2014
DUE DATE : APRIL 30, 2014

Please update address and contact information in the address block shown at the left.

3

WORKSITES

GO PAPERLESS! REPORT YOUR DATA ON THE WEB.
Web Instructions <http://www.bls.gov/cew/cewmwr05.htm>

* MWR WEB INFORMATION *
* ID: 10600012345 *
* Password: Aa123456 *

OFFICE USE	BUSINESS NAME (division, subsidiary, etc.) STREET ADDRESS (physical location) CITY, STATE, AND ZIP CODE WORKSITE DESCRIPTION (plant name, store number, etc.)	NUMBER OF EMPLOYEES <small>(subject to UI Laws) During the Pay Period Which Includes the 12th of the Month</small>			QUARTERLY WAGES OF WORKSITES <small>(subject to UI laws) Round to the nearest dollar</small>	
00001 000112 493120 031	ABC CORPORATION 456 FRONT STREET SOMECITY, UA 13245 SOMECITY OFFICE	JAN	1	1	2	
		FEB	1	1	1	\$ 1602522.00
		MAR	1	1	0	
00002 000033 493110 031	ABC CORPORATION 789 SIDE STREET ANYTOWN, UA 98765 ANYTOWN OFFICE	JAN	3	4		
		FEB	3	5	\$	395190.00
		MAR	3	6		
					\$.00	
					\$.00	
					\$.00	
					\$.00	
					\$.00	
		TOTALS	1	4	6	\$ 1997722.00

Note: The totals MUST agree (except for rounding) with your Form UTR1.

CONTACT PERSON (for questions regarding this report).
NAME: JANE SMITH
PHONE: (123) 456-7890

TOTALS
JAN: 1 4 6 \$ 1 9 9 7 7 2 2 . 0 0
FEB: 1 4 6
MAR: 1 4 6

0003310

EXHIBIT 3B Example MWR Print Form with more than employment and wages

UTANA DEPT OF LABOR
123 MAIN STREET
UTANACITY, UTANA 12345-6789
123-456-7890

Multiple Worksite Report - BLS 3020
Form Approved, O.M.B. No. 1220-0134
Expiration Date 05/31/2016
In Cooperation with the U.S. Department of Labor **BLS**

UTANA DEPT OF LABOR

Please fill out this form with blue or black ink.

1 This report is mandatory under UTANA LAW 123.456.789.0 and is authorized by law, 29 U.S.C. 2. Your cooperation is needed to make the results of this survey complete, accurate, and timely. The totals on this form must match the corresponding totals on your Employer's Quarterly Tax Report (Form 123).

2

ABC CORPORATION
JANE SMITH
123 MAIN STREET
SOMECITY, UA 12345-6789

QUARTERLY REPORT INFORMATION

U.I. NUMBER : 1234567890
QUARTER ENDING : MARCH 31, 2014
DUE DATE : APRIL 30, 2014

Please update address and contact information in the address block shown at the left.

3

GO PAPERLESS! REPORT YOUR DATA ON THE WEB.
Web Instructions <http://www.bls.gov/cew/cewmwr05.htm>

* MWR WEB INFORMATION *
* ID: 10600012345 *
* Password: Aa123456 *

OFFICE USE	BUSINESS NAME (division, subsidiary, etc.) STREET ADDRESS (physical location) CITY, STATE, AND ZIP CODE WORKSITE DESCRIPTION (plant name, store number, etc.)	NUMBER OF EMPLOYEES (subject to UI Laws) During the Pay Period (Which includes the 12th of the Month)	QUARTERLY WAGES OF WORKSITES (subject to UI laws) Round to the nearest dollar	
00001 00002 541310 071	ABC CORPORATION 456 FRONT STREET SOMECITY, UA 13245 SOMECITY OFFICE	JAN	/	
		FEB	/ \$ 20766.00	
		MAR	/	
00002 00002 541310 021	ABC CORPORATION 789 SIDE STREET ANYTOWN, UA 98765 ANYTOWN OFFICE	JAN	/	
		FEB	/ \$ 13305.00	
		MAR	/	
00003 00003 541310 115	ABC CORP 56 APPLE COURT SOMETOWN, UA 45632 SOMETOWN OFFICE	JAN	3	
		FEB	3 \$ 55491.00	
		MAR	3	
00004 00002 541310 109	ABC CORPORATION 99 SMALL STREET ANYPLACE, UA 45678 ANYPLACE OFFICE	JAN	2	
		FEB	2 \$ 15898.00	
		MAR	2	
00005 00000 541310 057	ABC CORP 321 SUNSHINE AVE SOMEPLACE, UA 98321 SOMEPLACE OFFICE	JAN	INACTIVE 6/30/13	
		FEB	\$.00	
		MAR	\$.00	
00007 000035 541310 095	ABC CORPORATION 654 MAIN STREET ANYCITY, UA 65432 ANYCITY OFFICE	JAN	35	
		FEB	35 \$ 713719.00	
		MAR	35	
Note: The totals MUST agree (except for rounding) with your Form UCT-6.		TOTALS	JAN	42 \$ 819179.00
<p>CONTACT PERSON (for questions regarding this report). NAME: JANE SMITH PHONE: (123) 456-7890</p>			FEB	42
			MAR	42

0003303

3.4.2 Solicitation and Informed Consent Letters

Potential respondents to the MWR must know whether or not the information they provide will be held in confidence and how this information will be used. For these reasons, the following statement must appear on all MWR forms used in every state.

“The information collected on this form by the Bureau of Labor Statistics and the state agencies cooperating in its statistical programs will be used for statistical and Unemployment Insurance program purposes, and other purposes in accordance with law.”

Solicitation Letters

The national office has developed two generic solicitation letters, (EXHIBITs 3C and 3E), to be mailed to (1) newly identified multi-establishment employers and (2) multi-establishment employers who previously did not submit the MWR. The national office has also developed a generic "informed consent" letter to be mailed to multi-establishment employers who have used the MWR before (EXHIBIT 3G), and a letter to be mailed to employers who no longer meet the definition of a multiple worksite employer (EXHIBIT 3K). The sample letters are generic so that all states can use them as a guide in developing their own letters.

Instructions for adapting the sample letters to each state are provided in EXHIBITs 3D, 3F, 3H, and 3J, respectively, along with an example of a hypothetical state letter for new multi-establishment employers (EXHIBIT 3L). The national office must approve the cover letters before they are used.

One state has developed samples of completed MWRs which it reproduces on the reverse side of the solicitation/cover letter. States using this approach must ensure that a copy of the latest form is used as a sample so it includes the most current confidentiality statement. The samples supplement the instructions by showing how the actual form should look when completed. A nice feature of the samples is that the preprinted information can be easily distinguished from the information the employer provides. One version of the form shows printed worksite identification information for an employer that previously provided it, and a second version shows how the form would look when used to collect the worksite identification information initially. States may consider using similar sample forms to improve the completeness and accuracy of employer reporting.

Letters to employers who previously did not report should be mailed one year after the initial solicitation letter is sent. If an employer fails to respond to the initial solicitation letter and follow-up letters after first being identified as a multi-establishment employer, a letter like that in EXHIBIT 3E should be sent the following year. If there is no response to this letter, no follow-up letters should be sent.

In many states, the employers are solicited via phone when the ARS form is received with information identifying the account as a new multi-establishment employer. States should also be aware of units pending EDI Center solicitation. The employer should not be contacted again until after the next Annual Refiling Survey, presumably when it is again identified as a multi-establishment employer. The following example should clarify this:

Suppose an employer responded via ARS Web first identifying itself as a multi-establishment employer in December 2018. With this information, the state solicited the employer to complete a MWR in March 2019. Follow-up letters were sent six and eight weeks later, but the employer did not respond. No attempt at solicitation was made in the second, third, or fourth quarters of that year. In March 2020, the state solicited the employer again using the letter for employers who did not report previously. Thus, one year after the initial refusal or nonresponse the employer was solicited again, using the letter in EXHIBIT 3E. If the employer did not respond to this letter, no follow-up letter would be sent and the employer would not be contacted again until at least March 2021 (or March 2024). Solicitation in March 2021 (or March 2024) assumes that the employer responded to the ARS again. Note that in this example, re-solicitation for MWR reporting is recommended for March 2021, because companies coded in certain low-change NAICS codes are on an every-sixth-year, rather than an every-third-year, ARS cycle.

The informed consent statement, which will be on all states' forms should also be referenced in the cover letters. States should provide brief descriptions of any non-statistical, non-UI uses of the data. A state's specific uses and confidentiality policies of MWR data should be distinguished from any national office uses and confidentiality policies of MWR data. If states publish industry directories, a broad description of uses and future uses of data released in these directories should also be disclosed in the cover letters.

EXHIBIT 3C Solicitation letter to new multi-establishment employers

Dear Employer,

The enclosed Multiple Worksite Report is designed to collect employment and wage data by location (worksite) from employers who conduct their business operations at more than one location within the State. This survey is authorized by 29 U.S. Code 2 and completion of the form is required by Section and Title of State Law. [1] The economic information collected on this form is shared with the U.S. Department of Labor's Bureau of Labor Statistics as part of a Federal/State cooperative effort to reduce employer reporting burden.

Employers fitting the above description are requested/required to complete this report. To do this, you should/must provide employment and wage information for each worksite (e.g., store, plant, office). Please review and update the worksite information preprinted on the attached report and provide a trade name (e.g., division, subsidiary) and worksite description (e.g., store number, plant name) for each of the listed worksites. Please add any omitted worksites and indicate units that are inactive, closed, or have been sold. A computer generated listing which includes all of the worksite information requested on the Multiple Worksite Report is acceptable in lieu of the form.

For employers in the construction industry, we are requesting that you provide information for only those projects which have an expected duration of twelve months or longer. Whether or not you have any projects of this length, please include your office location(s) on the report. [2]

The information collected on this form by the Bureau of Labor Statistics and the State agencies cooperating in its statistical programs will be used for statistical and Unemployment Insurance program purposes, and other purposes in accordance with law. Worksite-level data are necessary for this agency to prepare summaries of economic conditions and business activities by geographical area and industry within our State. State name may include purposes such as list additional uses of the data. [3]

This report should be returned in the postage-paid envelope enclosed. If you have any questions regarding these reporting procedures, please contact name and telephone number.

Thank you for your cooperation.

Sincerely,

Note: It might be useful to put a sample completed MWR form on the back of this cover letter so that these new respondents can see how it is supposed to be completed.

EXHIBIT 3D Instructions for solicitation letter to new multi-establishment employers

State-Specific Sections

All underlined words are state-specific and should be included if appropriate, or deleted if not.

[1] Include this underlined phrase if completion of the MWR is mandatory in your state.

[2] States have the option to add this paragraph if they think construction industry reporting needs to be specifically addressed.

[3] This sentence should be included by those states that use the data collected in this survey for purposes other than the statistical and Unemployment Insurance purposes mentioned in the first sentence of this paragraph. The state should complete the sentence with a brief description of these non-statistical uses of the data and be broad enough to cover any future uses.

EXHIBIT 3E Solicitation letter for multi-establishment employers who refused previous solicitation

Dear Employer,

Last year we contacted you to request your cooperation in completing a Multiple Worksite Report, but you either indicated that you were not able to, or chose not to, complete the form. However, because of the importance of the information, we are asking again for your cooperation. This survey is authorized by 29 U.S. Code 2 and completion of the form is required by Section and Title of State Law. [1] The economic information collected on this form is shared with the U.S. Department of Labor's Bureau of Labor Statistics as part of a Federal/State cooperative effort to reduce employer reporting burden.

Employers that conduct business operations in more than one location within the State are requested/required to complete this report. To do this, you should/must provide employment and wage information for each worksite (e.g., store, plant, office). Please review and update the worksite information preprinted on the attached report and provide a trade name (e.g., division, subsidiary) and worksite description (e.g., store number, plant name) for each of the listed worksites. Please add any omitted worksites and indicate units that are inactive, closed, or have been sold. A computer generated listing which includes all of the worksite information requested on the Multiple Worksite Report is acceptable in lieu of the form.

For employers in the construction industry, we are requesting that you provide information for only those projects which have an expected duration of twelve months or longer. Whether or not you have any projects of this length, please include your office location(s) on the report. [2]

The information collected on this form by the Bureau of Labor Statistics and the State agencies cooperating in its statistical programs will be used for statistical and Unemployment Insurance program purposes, and other purposes in accordance with law. Worksite-level data are necessary for this agency to prepare summaries of economic conditions and business activities by geographical area and industry within our State. State name may include purposes such as list additional uses of the data. [3]

This report should be returned separately in the postage-paid envelope enclosed. If you have any questions regarding these reporting procedures, please contact name and telephone number.

Thank you for your cooperation.

Sincerely,

Note: It might be useful to put a sample completed MWR form on the back of this cover letter so that the new respondents can see how it is to be completed.

***EXHIBIT 3F* Instructions for solicitation letter for multi-establishment employers who did not report previously**

State-Specific Sections

All underlined words are state-specific and should be included if appropriate, or deleted if not.

[1] Include this underlined phrase if completion of the MWR is mandatory in your state.

[2] States have the option to add this paragraph if they think construction industry reporting needs to be specifically addressed.

[3] This sentence should be included by those states that use the data collected in this survey for purposes other than the statistical and Unemployment Insurance purposes mentioned in the first sentence of this paragraph. The state should complete the sentence with a brief description of these non-statistical uses of the data and be broad enough to cover any future uses.

EXHIBIT 3G Informed consent letter for continuing MWR reporters

Dear Employer,

Thank you for your continuing cooperation in completing the Multiple Worksite Report. This survey is authorized by 29 U.S. Code 2 and completion of the form is required by Section and Title of State Law. [1] The economic information collected on this form is shared with the U.S. Department of Labor's Bureau of Labor Statistics as part of a Federal/State cooperative effort to reduce employer reporting burden.

Employers that conduct business operations in more than one location within the State are requested/required to complete this report. To do this, you should/must provide employment and wage information for each worksite (e.g., store, plant, office). Please review and update the worksite information preprinted on the attached report. Add any omitted worksites and indicate units that are inactive, closed, or have been sold. A computer generated listing which includes all of the worksite information requested on the Multiple Worksite Report is acceptable in lieu of the form.

For employers in the construction industry, we are requesting that you provide information for only those projects which have an expected duration of twelve months or longer. Whether or not you have any projects of this length, please include your office location(s) on the report. [2]

The information collected on this form by the Bureau of Labor Statistics and the State agencies cooperating in its statistical programs will be used for statistical and Unemployment Insurance program purposes, and other purposes in accordance with law. Worksite-level data are necessary for this agency to prepare summaries of economic conditions and business activities by geographical area and industry within our state. State name may include purposes such as list additional uses of the data. [3]

This report should be returned separately in the postage-paid envelope provided. If you have any questions regarding these reporting procedures, please contact name and telephone number.

Thank you again for your cooperation.

Sincerely,

***EXHIBIT 3H* Instructions for informed consent letter for continuing MWR reporters**

State Specific Sections

All underlined words are state-specific and should be included if appropriate, or deleted if not.

1. Include this underlined phrase if completion of the MWR is mandatory in your state.
2. States have the option to add this paragraph if they think construction industry reporting needs to be specifically addressed.
3. This sentence should be included by those states that use the data collected in this survey for purposes other than the statistical and Unemployment Insurance purposes mentioned in the first sentence of this paragraph. The state should complete the sentence with a brief description of these non-statistical uses of the data and be broad enough to cover any future uses.

***EXHIBIT 3J* Instructions for informed consent letter to MWR respondent using magnetic media**

State Specific Instructions

1. Firms reporting to state, only.
2. Firms reporting to Data Collection Center, only.
3. The phrase "is held confidential to the full extent permitted by law " should be included by only those states for which it is true.
4. This sentence should be included by those states that use the data collected on this survey for purposes other than the statistical and Unemployment Insurance uses mentioned in the second paragraph of the letter. The state should complete the sentence with a brief description of these additional uses of the data and be broad enough to cover any future uses.

EXHIBIT 3K Letter to multi-establishment no longer meeting MWR definition

Dear Employer:

Thank you for your past cooperation in completing the Multiple Worksite Report. The information you have provided is authorized by 29 U.S. Code 2 and is requested/required by State Law XXX-XXX.

The information obtained from this report is used for both statistical and Unemployment Insurance purposes to the full extent permitted by law. The worksite-level data provided by multi-business establishments are used to prepare summaries of economic conditions and business activities by geographical area and industry within our State. Because your most recent report indicated that you no longer meet the requirements necessary to identify multiple worksites within this State, you will no longer be requested to complete this report form. The Bureau of Labor Statistics has established ten as the minimum number of employees working outside of the primary worksite (defined as the largest worksite in terms of employment) for an employer to be considered a multiple worksite employer.

If at some future point your worksite employment in State should increase, such as through the addition of new worksites, you may again be requested to complete the Multiple Worksite Report.

Again, thank you for your cooperation. If you have any questions, please contact Mr. John Doe at (123) 456-7890.

Sincerely,

3.4.3 Review and Processing of MWR Data

The flow chart in EXHIBIT 3M is a useful guide for state staff as they review returned MWRs (paper forms or facsimiles) and process the data for existing multi-unit employers. While special circumstances may cause state procedures to differ slightly from this workflow, the activities shown are all needed to meet the full range of QCEW program needs. States whose processing of the existing MWRs deviates significantly from this workflow should review their current procedures to determine if the suggested workflow is more efficient.

The processing of MWR data collected by the EDI Center and through MWR Web, is covered in Chapter 4, Multiple Worksite Central Reporting.

When MWRs are received, they generally are in one of two formats: paper or facsimile (e.g., computer-generated report). Facsimiles are generated by the employer and may or may not resemble the MWR (BLS 3020) form. Paper MWR forms are printed by the state system and are returned by the employer.

In processing MWRs, both formats have common tasks. The main difference between the two is the assignment of RUNs. For facsimile copies, states have to compare the previous quarter's MWR to assign the RUNs to each worksite. This comparison varies by state. Some states write the RUNs on the facsimile and then transfer the RUNs to the current quarter's facsimile, while other states may reprint the previous quarter's MWR for the comparison. With the paper format, the RUNs are printed onto the MWR form, thus the assignment of RUNs is unnecessary (except for new worksites or locations).

Once the MWR is received, a cursory review prior to inputting the monthly employments and total wages should be made. This review should cover changes and/or comments made by the employer, and large data changes (employments and wages).

Employer changes could include the following:

- Mailing Address and/or contact name or phone number
- Trade Name and/or RUD for a worksite
- Address change for a worksite
- Narrative comments from the employer
- New worksites (locations)
- Worksites that are no longer in business (deaths) or transferred to another UI account
- Worksites that are sold
- Worksites that are broken out further
- Worksites that are combined (two or more worksites combine into one worksite)
- Worksites that transfer employees to another worksite (new or existing)

Changes to Mailing Addresses, Trade Names, RUDs, Physical Location Addresses (PLA), and narrative comments should be made immediately. If a PLA change causes the County code to change, assign the new County code and comment code 82 (economic code change).

For new worksites, additional information is needed to determine the action required. In most cases, a new worksite is a result of a new opening. These new worksites are considered "births" and NAICS, County, and Ownership codes should be assigned along with comment code 85

[new establishment or worksite]. In other cases, these new worksites may have come from another UI number (predecessor) or from another worksite within the UI account due to a transfer or merger. In these cases, refer to Chapter 5 to assign proper predecessor/successor links and comment codes.

Conversely, if an employer closes a worksite, it is considered a “death.” These worksites should be given an End of Liability (EOL) Date and comment code 86, establishment permanently out of business. As with new worksites, “deaths” could be caused by worksites that are sold to another UI account or by combining one or more worksites into one worksite. New RUNs should be assigned, if applicable. In these cases, refer to Chapter 5 to assign proper predecessor/successor links and comment codes.

If the UI number changes due to a merger or some other reason, add predecessor/successor links to the master and each RUN. Also, assign new RUNs (if applicable), appropriate comment codes, and termination dates to the master and each RUN for the predecessor. Refer to Chapter 5 for more information on processing predecessor and successor transactions.

EXHIBIT 3M Recommended processing flow for existing multi-establishment employers.

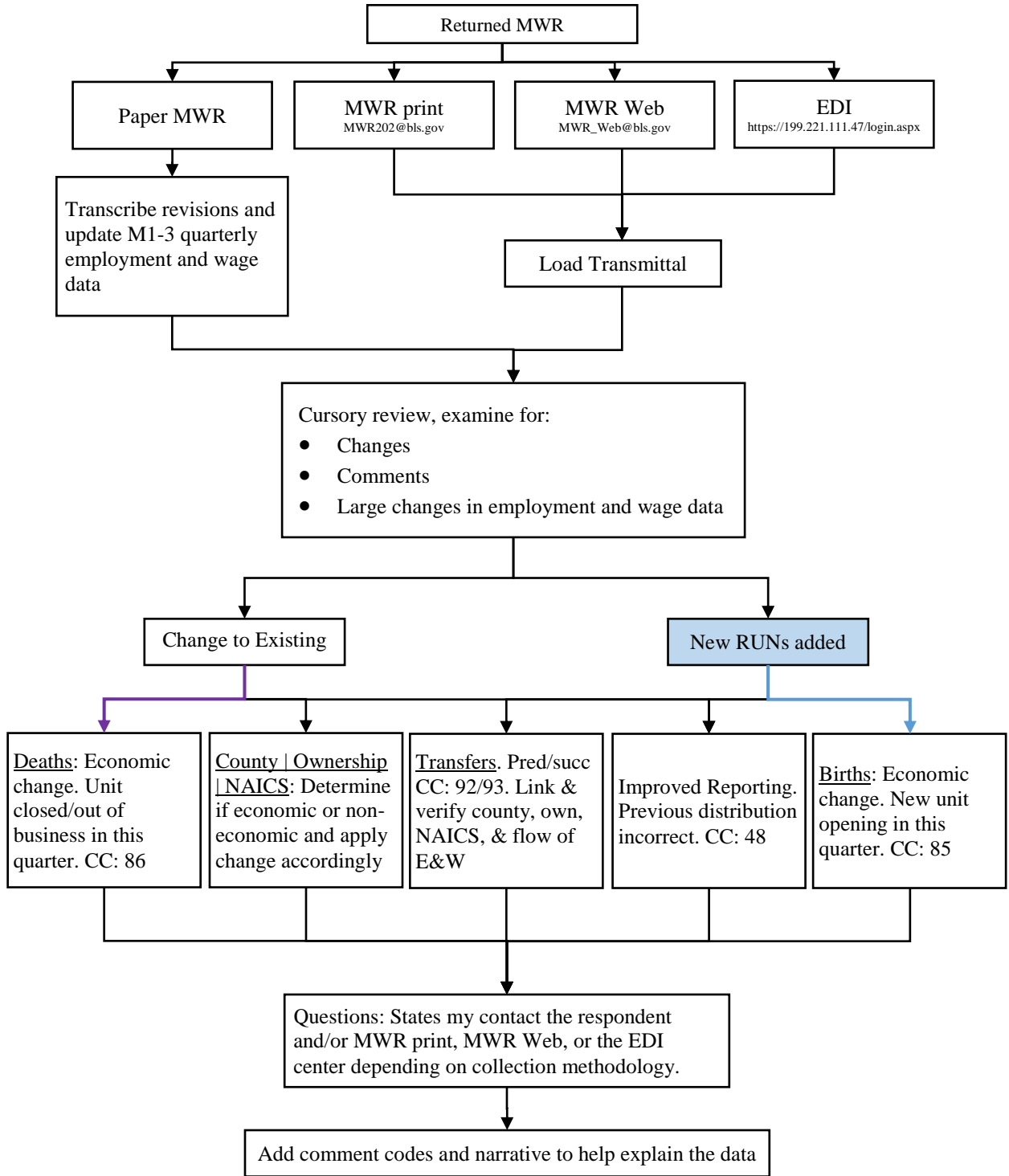

3.4.4 Delinquent MWR Reporters

The QCEW program depends upon accurate employment and wage data submitted by employers on a quarterly basis. This is especially important since the QCEW program is publishing on a quarterly basis. Much of these quarterly employment and wage data comes from the Multiple Worksite Report. For this reason, MWR reporters who are delinquent in submitting their quarterly reports must be contacted as soon as possible to obtain the necessary information. This will ensure that the QCEW data are timely and accurate.

The state of Louisiana created a follow-up cover letter that has proven very effective in soliciting information from delinquent MWR reporters. Their form has been modified by national office for use in all states. EXHIBIT 3N contains a template that should be used for contacting delinquent reporters in voluntary states, and EXHIBIT 3O contains a template for use in mandatory states.

When using the templates, states must replace the generic information found within the form's body with state-specific information. This information includes state Workforce Commission name, relevant state laws, state data uses, state contact names, and state contact telephone numbers. A MWR form must be enclosed with the cover letter. The cover letter also mentions the alternative methods by which an employer may submit MWR data in addition to returning the MWR paper form.

EXHIBIT 3N Cover Letter for Delinquent MWR Reporters (Voluntary States)

Dear Employer:

RE: Failure to Report Notice – Multiple Worksite Report

The (insert State Workforce Commission) sends your company quarterly the Multiple Worksite Report that is a nationally standardized form to collect employment and wage data from employers that have more than one location or economic activity in (insert state). This survey is authorized by 29 U. S. Code 2 and completion of the form is requested by (insert State Law XXX-XXX). Our records indicate that your company is not completing and returning this form to our office.

The information collected on this form, by the Bureau of Labor Statistics and the (insert State Workforce Commission) cooperating in its statistical programs, will be used for statistical and Unemployment Insurance (UI) program purposes, and other purposes in accordance with law. In addition to the statistical and UI uses of these data, (insert State Workforce Commission) also uses the data for (insert state data uses). The information supplied on this report is a direct input into the unemployment rate for (counties/townships/parishes) throughout the state and can affect government funding to these (counties/townships/parishes).

We have enclosed the **Multiple Worksite Report** form, designed to collect employment and wage information quarterly for each worksite (e.g., store, plant, office), preprinted with the latest available information on your company. Please review the form and update the worksite information by adding any omitted worksites and indicate units that are inactive or have been sold. A reporting unit number will be assigned to each location and/or establishment and will become a permanent identification number for that particular worksite.

In order to reduce your workload, we will accept a computer-generated listing that includes all the requested information including the reporting unit number that we have assigned to each location.

We appreciate your cooperation in this matter. If you have any questions concerning this report, please contact (insert name) at (insert state phone #).

Sincerely,

***EXHIBIT 30* Cover Letter for Delinquent MWR Reporters (Mandatory States)**

Dear Employer:

RE: Failure to Report Notice – Multiple Worksite Report

The (insert State Workforce Commission) sends your company quarterly the Multiple Worksite Report that is a nationally standardized form to collect employment and wage data from employers that have more than one location or economic activity in (insert state). This survey is authorized by 29 U. S. Code 2, and completion of the form is required by (insert State Law XXX-XXX). Our records indicate that your company is not completing and returning this form to our office, and is therefore not in compliance with the above referenced statute.

The information collected on this form, by the Bureau of Labor Statistics and the (insert State Workforce Commission) cooperating in its statistical programs, will be used for statistical and Unemployment Insurance (UI) program purposes, and other purposes in accordance with law. In addition to the statistical and UI uses of these data, (insert State Workforce Commission) also uses the data for (insert state data uses). The information supplied on this report is a direct input into the unemployment rate for (counties/townships/parishes) throughout the state and can affect government funding to these (counties/townships/parishes).

We have enclosed the **Multiple Worksite Report** form, designed to collect employment and wage information quarterly for each worksite (e.g., store, plant, office), preprinted with the latest available information on your company. Please review the form and update the worksite information by adding any omitted worksites and indicate units that are inactive or have been sold. A reporting unit number will be assigned to each location and/or establishment and will become a permanent identification number for that particular worksite.

In order to reduce your workload, we will accept a computer-generated listing that includes all the requested information including the reporting unit number that we have assigned to each location.

We appreciate your cooperation in this matter. If you have any questions concerning this report, please contact (insert name) at (insert phone #).

Sincerely,

3.5 When Quarterly MWRs Are Unavailable

There may be instances in which a multi-establishment employer either refuses or is unable to provide a complete establishment-level breakout on a quarterly basis. To ensure the validity and reliability of the QCEW data, both industry and county breakouts are necessary. Therefore as an interim measure – until such time as the employer can provide complete establishment breakouts each quarter – state staff should take the following steps, in the order they are listed, to obtain the necessary data.

Yearly Submission of a Breakout

If state staff determine that it is impossible for the employer to provide an establishment breakout each quarter, the state agency should negotiate an alternative solution with the employer. One solution might be for the employer to submit a complete establishment breakout for one quarter each year. The state can then prorate the aggregate data for the remainder of the year. (See Section 8.3.2 for the proration procedures.) The national office prefers that the first quarter data be obtained. However, if the first quarter is not representative of the other quarters in the year, states should work with the firm to select the most representative quarter's data for that employer. For school districts, it is preferable to have two quarters of data each year – the third quarter (the beginning of the school year) and the second quarter (the end of the school year).

Compiling a Breakout from Other Available Records

It is preferable that data by establishment be obtained from the employer even if it must be provided on some schedule other than a quarterly basis. However, if such a solution cannot be negotiated with the employer, state staff should attempt to compile establishment breakouts using various other sources of information available. These sources include the employer's wage records.

One of the best sources of information on some large employers is the company's website. Many of these firms list all of their locations for their customers' convenience. It is better to use this information and prorate the employment and wage data from the Quarterly Contributions Report (master record) than to collapse this record to one county or a statewide report.

Employer's Wage Record

The wage records can be useful in approximating breakouts by establishment. If possible, sort by establishment and the establishments' addresses. However, even when the data are not arranged by establishment, it may still be possible to determine breakouts for smaller multi-establishment accounts. This determination will be possible if establishment identifier codes are provided along with names, addresses, or other types of identifying information. Location of stores identified by store numbers can usually be obtained by calling the corporate office and requesting a list.

One limitation of the wage records is that it includes data for all employees for the account – not just those employed during the pay period including the 12th of the month. Thus, in approximating employment data for establishments, state staff should consider the impact of employee turnover and any other factors that could result in fluctuations of the data.

Furthermore, controls should be set up to ensure that the sum of approximated employment data for individual establishments does not exceed the total reported employment for the employer on the contribution report.

State staff should be cognizant of the limitations involved in using wage records to approximate establishment data.

Handling a New Breakout for an Uncooperative Employer

In some instances the employer may have been unable or unwilling to provide establishment, industry, or county breakouts on a quarterly basis or on any other schedule. State staff may have contacted the employer to negotiate yearly submission and then reviewed other available records – all to no avail. The state agency may have exhausted all acceptable methods for obtaining establishment breakouts, including business directories, the internet, etc. In this case, **as a last resort**, the following procedures should be used to properly code the data for the multi-establishment employer.

1. The primary county should be identified.

States should consider primary county as the county with the largest share of the employment in the account, but should only code to primary county when 50% or more of the total employment is in the primary county.

Some examples of this primary county coding concept are presented below.

Example 1: A multi-unit account has the following locations.

Location	Employment	County
A (primary)	8	001
B	2	003
C	7	003

The state should assign county 003 to the single unit (combined) record because the employment for this county is more than 50% of the total employment for the account.

Example 2: A multi-unit account has the following locations.

Location	Employment	County
A	2	101
B	3	103
C	1	105
D (primary)	4	107

The state should assign county code 995 (Statewide, locations in more than one county, or no primary county) to the single unit (combined) record because the primary county's employment (location D) does not make up 50% or more of the total employment for the account. County code 995 should also be used if state staff have exhausted every source of information, including estimates by the employer, and is still unable to determine whether 50% or more of the employees work in the primary county.

2. The primary industry should be identified.

The primary industry is the industry with the largest revenue or receipts. Sometimes, however, where diverse industrial activities exist for a multi-establishment employer, revenues or receipts cannot be determined or estimated for each product or service. In other instances, the revenues or receipts for each product or service do not adequately reflect the economic importance of each establishment within the firm. In these situations, as well as for agencies involved in public administration, employment or payroll information should be used to determine the primary industry.

The state must determine the approximate employment for the primary county and primary industry. Information from the following sources should be used in determining employment: employer contacts, employer wage records, industrial classification statements, newspaper articles, information gathered during previous attempts to obtain establishment breakouts, and any other sources available.

If the industry breakout is not available, then the state should code all the employer's establishments into the primary industry as previously defined.

3.6 Report of Federal Employment and Wages

The national office collects the RFEW from federal departments and agencies. This is discussed in Section 4.6, Central Reporting of Federal Data. Presently, federal employment and wage data are centrally collected by the EDI Center in Chicago for virtually all federal civilian employment.

Federal Agency Delinquency and Data Problems Resolution

Questions on federal agency data supplied by the EDI Center should be addressed to the EDI Center staff using their existing form.

State Agency Publication of Federal Civilian Employment and Wage Data

Federal civilian employment and wage data are subject to provisions of the Freedom of Information Act. Accordingly, there are no restrictions on state publication of federal government civilian employment and wage figures, including Department of Defense civilian

employment and wage data. The Privacy Act of 1974 does not prohibit disclosure of the salaries paid to individual federal government employees.

Chapter 4 – Multiple Worksite Central Reporting

BLS developed the central collection of Multiple Worksite Report (MWR) and Report of Federal Employment and Wages (RFEW) data to streamline the process of data collection from large employers and clients of payroll outsourcing firms. The Electronic Data Interchange Center (EDIC) in Chicago, Illinois is responsible for processing and editing the data and forwarding the clean data to the states each quarter. States are able to access their quarterly MWR and RFEW data provided by the EDIC through Employment and Unemployment Statistics (EUS) Web, as well as through the Data Management Associates (DMA). State staff should then use their state processing system to load their quarterly electronic MWR/RFEW files directly to their QCEW micro database files.

To supplement central data collection by the EDIC, the national office also collects MWR and RFEW data via the internet. The MWR Web application at the Internet Data Collection Facility (IDCF) allows employers with a small to moderate number of worksites, or their payroll outsourcing firms, to report their data centrally. See Appendix A for the flowchart.

----- Contents of Chapter 4 -----

- 4.1 Data Collection by the EDI Center
- 4.2 Data Processing at the EDI Center
- 4.3 Communications between the EDI Center and the States
 - 4.3.1 Coordinating the Employer's Transition to Central Reporting
 - 4.3.2 New and Discontinued Worksites
 - 4.3.3 Data Transmission to the States
- 4.4 Communication with Central Reporters
- 4.5 Handling Special Situations
 - 4.5.1 Data Quality
 - 4.5.2 Employment and Wage Totals
- 4.6 Central Reporting of Federal Data
- 4.7 Employer Reporting of MWR Data Directly to States
- 4.8 MWR Web Internet Data Collection

4.1 Data Collection by the EDI Center

BLS developed the central collection of the MWR and the RFEW data to streamline the process of data collection from large employers and clients of payroll outsourcing firms. With the opening of the EDIC in February 1995, multi-state employers have the option of submitting their data for all states to one location instead of multiple state agencies. The central collection option (which requires just one data submission per quarter per account) encourages large employers, who may have refused in the past to complete the MWR or RFEW in all or some states, to begin reporting their data at the worksite level. The EDIC maintains a list of centrally reporting firms and payroll outsourcing firms on its website.

Companies submit their data to the EDIC using a 350-position ASCII or EXCEL spreadsheet record format. The current file formats appear in Appendix N. EDI only offers MWR Web Upload or FTP file transmission methods for new firms. Please note that the EDIC collects data only for the QCEW (MWR and RFEW) and CES programs.

The standard state systems have been programmed to accept the 424-position format shown at the beginning of Appendix N (the first export layout), so the EDIC transmits employers' data to the states in this format. The EXPO system also maintains the capability of handling the 310-character format for employers that still use the earlier 310-character format and report directly to the state.

The electronic MWR and RFEW data received from an employer may contain single-unit Unemployment Insurance (UI) Accounts in a state. However, the EDIC does not export the data for single-unit accounts of private sector companies. These employment, total wages, as well as taxable wages and contributions data are provided by the employer directly to the state on the Quarterly Contribution Report each quarter. Only data from the National Finance Center (NFC), Department of Defense (DoD), and other federal agencies can have zero-filled Reporting Unit Numbers (RUN) and still be exported. The main reason that single worksites can be exported for federal agencies is that there are no corresponding Quarterly Contribution Reports (QCR) filed with UI staff for these accounts. For private sector UI accounts, data from the QCR are used.

The EDIC receives additional QCEW data from some federal agencies that previously provided their data directly to the states via RFEW forms or on computer printouts. The EDIC currently receives data from the Defense Manpower Data Center (DMDC) for civilian Department of Defense), the National Finance Center (NFC) for Departments of Agriculture, Treasury, Commerce, Justice, Labor, FBI, and Homeland Security, as well as many other smaller independent agencies, General Services Administration (for itself and many smaller agencies), the Interior Business Center of the Department of Interior (for Interior, Transportation, Social Security Administration (SSA), and many smaller agencies), the Department of Energy, the Environmental Protection Agency, the Navy Exchange, and the Army Non-Appropriated Fund (NAF) activities. The EDIC expects to collect data centrally for additional federal agencies in the future. Section 4.6 describes the central collection of federal data in more detail.

4.2 Data Processing at the EDI Center

The EDIC is responsible for editing, reviewing, and exporting data to the states.

The EDIC uses the system for processing large volume employment data (SLED) system to load and process the reporter file (the file provided by the employer or payroll outsourcing firm). The SLED system loads incoming data, performs edits, incorporates crosswalks, aggregates records (when applicable), identifies missing records, identifies new (i.e., birth) records, and builds/maintains historical files.

SLED System Processing

SLED first performs basic pre-edits to check for any problems or systematic discrepancies on the firm's data. The system later performs more extensive (detail) editing on employment, wages, and other fields of the firm's file. The edits performed in SLED have the same requirements as those edits performed in the national office and state QCEW processing systems. However, the SLED edits can only use the data elements and records collected by the EDIC. For example, SLED cannot compare Total Wages with Taxable Wages because the EDIC does not collect Taxable Wages. SLED cannot perform balance (additivity) edits between worksite records and their master record because the EDIC does not have access to master records. Also, SLED processes and edits only one address block per record – the physical location address fields.

The EDIC staff can assign up to three comment codes and a narrative comment to help explain questionable data. SLED also identifies and processes missing/potentially out-of-business records (that is, those records provided by the firm in the previous quarter but not on their current quarter file submittal). Missing/out-of-business records are identified by comment code 86 (establishment permanently out of business), or possibly by other appropriate “missing record” comment codes such as 88 (establishment dissolution) or 18 (active employer reporting zero employment and wages) or 93 (successor UI/Run).

SLED identifies and displays single unit records for private sector firms, although the EDIC does not export the data for single unit accounts of private sector firms. These employment, total wages, as well as taxable wages and contributions data are provided by the employer directly to the state on the QCR report each quarter. Only data from federal agencies can have zero filled RUNs and still be exported.

SLED performs inter-quarter edits on employment and wage fields. These edits check for unusual fluctuations in the data. (Again, the EDIC staff may assign up to three comment codes and a narrative comment to help explain questionable data.) The SLED system then identifies and edits birth records, which are typically records that have not been previously provided by the firm. The EDIC will provide the NAICS, County/Township, and Ownership codes on birth records and assign comment code 85 (new establishment or worksite) or 90 (reporter changes basis of reporting – greater detail) or 92/93 (successor record). States must still verify codes applied are valid once they are in the State system.

Next, SLED performs non-wage/non-employment edit checks and identifies changes in fields from the previous quarter, such as Reporting Unit Descriptions (RUDs), address fields, Employer Identification Numbers (EINs), and name fields (Trade, Legal). SLED edits are further described in Appendix O.

The EDIC will also enter predecessor/successor (P/S) UI and RUNs to report mergers, transfers, acquisitions, closed/sold businesses, and other similar reporting changes. These are entered into the SLED system (along with comment codes 92 or 93 as applicable on reporter records) prior to exporting the data to states so that P/S information will be transmitted as needed. The P/S information record(s) are provided immediately below the full detail 424-length reporter record as applicable. Please note that not every detail record will have P/S records. Finally, SLED exports the quarterly data to the states via EUSWeb and DMA.

Professional Employer Organizations (PEOs)

Input files provided by Professional Employer Organizations (PEOs) are processed identically to other reporter input files. In addition, PEO input files also have any client-related data (Client UI Account Number, Client EIN, Client SIC/NAICS code, Client Telephone Number, Client Worksite Economic Activity, month/year became client of PEO, and month/year client left PEO) copied to a separate system table which holds the data for later export to states. The client data can also be updated by the EDIC during the course of processing the PEO reporter file through the SLED system.

SLED Crosswalk Process

A number of companies that supply MWR data may not be able to, or refuse to, supply state-assigned UI Account Numbers and/or RUNs. This may occur because the UI Account Numbers may not be configured as needed by the state, and the RUNs are not likely to be stored by the employer. The crosswalk function within SLED is designed to accommodate this problem by translating an employer's unique worksite identifiers into unique state FIPS Code-UI Account Number-RUN combinations. The employer-specific crosswalk is set up in the employer's transition to central reporting.

In performing a crosswalk, SLED attempts to match the crosswalk identifier (the employer's own unique identifier) on the reporter file against the company identifier in their crosswalk information. Should the crosswalk find a match, SLED copies the UI Account Number and RUN (the ones that need to go to the state) from the reporter's crosswalk information onto the appropriate reporter file record. If the crosswalk does not find a match, SLED processing will identify non-matches and require resolution of these before processing continues. To continue, the staff at the EDIC perform the following tasks:

1. Update the reporter's crosswalk information, or
2. Modify certain fields on the records that were not matched so that the records can be matched with existing records on the reporter's crosswalk information.

Data Distribution

The EDIC is responsible for processing and updating the data sent by firms and providing these data to the states as clean as possible each quarter. The EDIC transmits the data to the states via EUSWeb and DMA. It is possible for a state to receive more than one set of data per quarter from the EDIC since they process and export data for multi-unit account firms and installations that have locations in more than one state.

States use EUSWeb and DMA as needed to retrieve their data for incorporation into their files after the EDIC notifies them (via email) that their quarterly data are available. The data includes continuous (quarter-to-quarter) records, birth records, and missing/out-of-business records. Continuous records should match one-to-one to records on State systems. The EDIC separately identifies birth records to the states by assigning a comment code of 85 (new establishment or worksite) or 90 (reporter changes basis of reporting – greater detail). Missing/out-of-business records are identified by comment code 86 (establishment permanently out of business), or possibly by other appropriate “missing record” comment codes such as 88 (establishment dissolution) or 18 (active employer reporting zero employment and wages) or 83/99 (employee leasing reporting change to or from a PEO).

To inactivate reporting units, state staff change the status code to 2 and assign an appropriate End of Liability Date in the state system. If no better date is available, use the last date of the last active quarter (for example, use March 31, 2020 if the last active quarter is the 2020 first quarter).

4.3 Communications between the EDI Center and the States

Communication between the EDIC and the states usually pertains to one of the following four topics:

1. Coordinating an employer's transition from reporting directly to the states to reporting to the EDIC.
2. Transmitting data that pertains to new firms and/or firms that no longer report to the EDIC.
3. Transmitting quarterly data.
4. Questions and/or clarifications on data.

In addition, the EDIC will request that states provide email addresses, mailing addresses, fax numbers, etc. States should respond in a timely manner.

The EDIC does not provide support for EUSWeb or DMA. Email EUSComm@bls.gov for questions or problems associated with EUSWeb. You can also call LAN support at (202) 691-5950; be sure to identify yourself as a state user.

4.3.1 Coordinating the Employer's Transition to Central Reporting

A firm reporting to the EDIC requires a setup period and various coordinating activities. These activities include the identification of correct UI/RUNs; appropriate transmission method of data from the firm to the EDIC; establishment of contacts with the firm for resolving data problems; and providing information to the states on the firm.

Generally, the EDIC will use the ES-202 Database (EDB) and Longitudinal Database (LDB) to identify the correct UI/RUNs.

Before beginning live reporting of MWR data to the EDIC, an employer will send a test file. The EDIC will review the test file's format and content. This policy ensures the file is sent correctly and appears usable. Additional test files may be needed before the EDIC approves the reporting as acceptable. The length of the testing phase can vary significantly. During the test phase, employers normally continue to send paper copies of the MWR directly to the appropriate state agencies.

In nearly every state the UI Account Number assigned by the tax division within the state is not in the same format or length as that used by the research division within the state. For this reason, the UI Account Number configuration is reviewed. (The state research division is responsible for the MWR.) For example, one format may contain leading zeros or a hyphen followed by a suffix, while another format does not. Thus, there may be some variation in the format of the UI numbers among the QCR, MWR, and the Annual Refiling Survey (ARS) forms. The use of the proper UI number is critical.

EDI has developed a process to ensure that states and the EDI Center are using the same UI/RUN numbers. It is called the EDI New Firm RUN Matching Project. The process is outlined below.

Process

1. Review the UINs/RUNs that were automatically assigned (matches were made based on EIN, Trade Name, and Address). Make any needed corrections.
2. Fill in the blank UINs/RUNs. They will either be:
 - **Singles:** Fill in the UINs and set RUNs = 00000. No other information needs to be filled.
 - **Existing Records:** Fill in the UINs/RUNs that correspond with each record. No other information needs to be filled.
 - **New Records for an Existing Multi:** Fill in the UINs/RUNs that you would like EDI to assign to each record. Fill in the NAICS, CTY, TWN, and CC (i.e. – 85) for the new records in the appropriate NAICS, CTY, and CC fields.
 - **New Breakouts** (State has the UIN as a single, but EDI received it broken-out): Fill in the UINs/RUNs that you would like EDI to use this quarter. Fill in the NAICS, CTY, and CC for the records in the appropriate NAICS, CTY, and CC fields. **Note:** If you wish to wait until 1st quarter to break-out the records, set RUNs = 00000 and add “Breakout 1st quarter” to the Comment fields.
 - **Predecessor/Successor:** Fill in the UINs/RUNs that you would like EDI to assign to each record. Fill in the NAICS, CTY, and CCs for the records in the appropriate NAICS, CTY, and CC fields. For a link to be created, be sure to put the appropriate Pred/Succ info in the Comments field.

3. Review the Addresses, Trade Names, and Legal Names and make any needed corrections in the corresponding Address, Trade Name, or Legal Name fields. Make a note of the correction in the Comments field (ex: "Zip Code has been corrected").
4. If you want to collapse two lines into one RUN, assign the same UIN/RUN combination to both records.
5. Do NOT change the WIC field (column E), as this field is crucial to EDI processing. Put all codes (i.e. – CCs, NAICS, CTY) in the appropriate fields and put all notes for EDI in the Comments field only.
6. As a reminder, if a record has no CC, EDI will assume the record already existed and it will be exported with blank CTY and NAICS fields.

The EDIC staff will inform the states via email when a new reporter will transition to the EDIC. States will need to know when an employer will begin reporting to the EDIC because the states must make these processing changes:

1. Stop mailing the company a paper copy of the MWR form,
2. Stop sending the company reminder notices or calling the employer when the MWR is not returned to the state, and
3. Stop contacting the employer with questions about the employer's data. Contact the EDIC instead.

4.3.2 New and Discontinued Worksites

Birth File

The SLED system uses the files listed below to process birth records contained on the reporter file:

- Reporter File – File from the reporter (employer or payroll outsourcing firm) supplying the data to be processed by the EDIC.
- Historical Employment File – SLED compares the data on the reporter file with the data on the Historical Employment File. No matches indicate a birth record.
- Birth File – File that contains all birth records.

After SLED completes the inter-quarter edits, it determines the number of birth records submitted on the reporter file. To accomplish this, SLED determines which records submitted on the reporter file do not reside on the Historical Employment File. (The Historical Employment File contains up to five quarters of data.) The Historical Employment File uses the following three fields to uniquely identify a record:

- State FIPS Code
- UI Account Number

- Reporting Unit Number

During birth record processing, EDIC staff must provide all birth records with a comment code of 85 (new establishment or worksite) or 90 (reporter changes basis of reporting – greater detail), and the correct NAICS, County/Township, and Ownership code on the record sent to the states. (None of the elements may be blank, but the Township field will be zero filled for most states.)

SLED exports records of new (birth) establishments to the states via EUSWeb and DMA. SLED differentiates these records from records of existing (continuous) establishments by including the codes mentioned above and a comment code of 85 or 90. SLED maintains a separate file of birth records, called a Birth File, although it does not use this file in the processing of data. Another useful source that the EDIC employs for identifying birth records is through the SLED crosswalk processing function.

Missing/Out-Of-Business Records

As mentioned earlier, the SLED system identifies records that are missing or potentially out-of-business for review by the EDIC. Missing records are normally those that are not on the current quarter reporter file but were provided by the reporter on their previous quarter file submittal.

Records identified as missing and truly out-of-business can be added back to the reporter file with a comment code of 86 (establishment permanently out of business) for export to the states. Other appropriate comment codes for additional “missing record” situations could include codes such as 88 (establishment dissolution) or 18 (active employer reporting zero employment and wages) or 93 (successor UI/Run). If the EDIC adds a missing record back to the reporter file as a result of a predecessor/successor transaction, the EDIC will provide comment codes and successor information in the narrative comment field on that record.

4.3.3 Data Transmission to the States

Two methods are used by the EDIC to transmit the data to the states. One is EUSWeb. The other is via DMA for states who do their processing of QCEW data via DMA.

Quarterly data exported electronically to the states from the EDIC will be in the first export layout shown in Appendix N. Additional predecessor and successor UI and RUNs are exported within the 424 position export file as supplemental records below each “detail” 424 position record as applicable. Please note that not every detail record will have supplemental predecessor/successor records.

In addition to the exporting of quarterly data, the EDIC will use email to provide additional information about the data that is not included on the data transmission. Additional information may include the following:

- Changes in processing procedures since the previous quarter
- Closed/sold/merge information

- New reporter announcements
- Reporters who have left the EDIC
- Problem firms, such as ones that did not report for a particular quarter
- UI accounts for which no data are being transmitted because the UI accounts changed from a multiple reporter to a single reporter and no longer qualify as a central reporter
- List of known predecessor/successor information

Employers will be required to report their MWR data to the EDIC by the date that they are currently required to report to the states, which is one month following the end of the reference quarter. The EDIC will notify states via email whenever their quarterly data for a firm are available using EUSWeb and DMA. If a firm is late transmitting their data so as to affect the final transmission date of data for the current quarter, states will be notified via email about the delay, its causes, and the anticipated receipt date.

Each state's quarterly data exported from SLED to EUSWeb has a filename consisting of the state's abbreviation plus the current day's date and time with a .DAT extension. For example, "CT011620.t1602.dat" contains Connecticut's data for January 16, 2020 at 4:02pm. The "1602" after the letter "t" is 4:02pm on the 24-Hour Clock. Please note that there may be more than one file for a state for a given quarter. Also, the file size (byte) limit for transferring files via EUSWeb is 10MB.

Each state's quarterly data exported from SLED to DMA has a mainframe dataset name which contains, as part of the dataset name, the word "CENCO", the state's abbreviation, and a date and time of the dataset. For example, "YBU56X.A145.CENCO.WY072120.T1600" contains Wyoming's data for July 21, 2020, 4:00pm. As above, the "1600" after the letter "T" in dataset name example is 4:00pm on the 24-Hour Clock. Again, please note that there may be more than one dataset for a state for a given quarter.

NOTE: States must still review the data and confirm all comment codes applied are valid.

4.4 Communication with Central Reporters

All communication with employers that submit their data centrally to BLS must go through the EDIC. Personnel in the EDIC will be responsible for contacting these employers. The EDIC staff will develop company contacts that can answer questions not necessarily related to employment and wages information. An additional contact person will be identified to answer questions relating to opening of businesses. Other persons, if needed, will be identified to contact concerning closings of establishment locations or to handle predecessor/successor relationship issues. States should contact the EDIC (and not regional offices nor respondents) via the EDI website with questions on data received from the EDIC. The EDIC will contact states or go through the regional offices, depending on the issue and timing.

States must submit their questions or change requests via the EDI website only using the online web-based form at <http://199.221.111.170/edi/mwrquestion.asp>. Questions on data should be requested within four weeks of the availability of data and should include the following specific information:

- Firm name
- UI Account Number
- RUN
- EIN
- Sender's name, work phone number, email address
- Resolution sought

Staff at the EDIC will complete their part of the online web form and send a reply to the state. The form will contain the name and phone number of the EDIC staff person that handled the request. The email reply will be addressed to the person who sent the request. Should the state have a question concerning the reply, a state staff person should contact that EDIC staff member to resolve the issue. The EDI Question/Clarification Request Form contains a section to note the final resolution of the issue and the date that the resolution was reached. This procedure will allow the EDIC to maintain an electronic file of all inquiries and their responses. It will also facilitate the ability to send a question/response raised by one state to all states, if applicable, without having to re-write the message had the initial question been sent via fax. The requests to change UI numbers or RUNs will be reflected in the next quarter's data. The EDIC will respond to all correspondence via email.

To improve the way the EDIC responds to questions (the timeliness of responses and the ability of states to track their submitted questions/changes), two enhancements have been implemented.

Preliminary versus Final Responses

The EDIC now has the option of sending out preliminary responses or final responses to state questions. Having this option now allows EDIC staff to provide partial information when available, or to provide feedback indicating that EDIC has communicated with the company and is awaiting a response. This way, state staff that send questions will be reassured that EDIC is researching their answer. In the past, states would not have heard anything from EDIC until an answer was complete. If only partial answers to state questions are available, EDIC will be able to send such information to states.

The subject line of the email states receive from EDIC will say whether the reply is a preliminary or final response. The questions will remain active in EDIC's system until a final response goes out. Once a final response goes out, the question will be archived.

Tracking of State Questions

State technicians may review a list of all unanswered and archived questions reported by their state. From the home page of the EDI website, click on "STATE Login" to access state-specific questions and change requests. Users must have a login id and password to access this option. The EDIC will send out state login ID's and passwords in separate emails. Regional office staff may request login ID's and passwords for their respective states to view each states' questions individually.

After logging in, a user can access either change requests or question requests. Both changes and questions are organized by groups -- outstanding and answered (archived). The questions and changes on the screen are specific to each state, so one state cannot view questions from other states. The screen may be sorted by Date, Firm Name, Firm Code, Quarter and Year.

If there are any problems to report, the HELP section has a "Report Problems" feature that allows a state to report a data or web problem directly to the EDIC programming staff. This is the quickest, most efficient way to report any problems.

The toll-free telephone number of the EDIC is 1-800-861-3804. This number should be used in rare cases. The preferred method of contact is via email to EDICTR-CHI@BLS.GOV, unless the reason has to do with a question/change on exported data. The mailing address for the EDIC is below.

BLS/EDI Collection Center,
230 South Dearborn Street, 9th Floor
Chicago, IL 60604

States should send a copy (“cc”) of any email communication they may have with the EDIC to their regional office. States should inform their regional office of any significant telephone contact made with the EDIC. Likewise, states should send a copy (cc) of their request for assistance or response to a request from the EDIC to their regional office. The EDIC will send a copy (cc) of a response to a state to the appropriate regional office.

All requests by the EDIC for state information will be directed to the state with a copy to the respective regional office. The states should send the requested information to the EDIC and cc: the appropriate regional office noting its submittal. Should a reply not be provided in a timely manner, the EDIC will send a follow-up request to the regional office which will be responsible for ensuring a reply to the request. Each state will designate a contact person, plus a back-up person, to handle EDIC requests.

Each quarter, the national office also sends three reminder emails each quarter to EDI reporters. These reminder notices are sent out every other week by DBES, and the recipients are routinely verified by EDI. Responses to these emails are collected and transmitted in the same way as other EDI web collection. An example of a reminder email is given in EXHIBIT 4A.

EXHIBIT 4A Email to EDI Reporters

Dear XXXXX,

It's time to submit your company's employment and wage data for the BLS 3020 - Multiple Worksite Report (MWR). The MWR for this quarter is due on **1/31/2018**.

Please log on to our secure website to upload your report: <https://idcf.bls.gov>

USER ID: **CSXXXXXXXX**

If you have any questions, please contact us at EDICTR-CHI@bls.gov.

Thank you,

U.S. Department of Labor

Bureau of Labor Statistics

EDI Center

The Bureau of Labor Statistics (BLS) is committed to the responsible treatment of confidential information and takes rigorous security measures to protect confidential information in its possession. Per the Cybersecurity Enhancement Act of 2015, Federal information systems are protected from malicious activities through cybersecurity screening of transmitted data. This email contains confidential information. If you believe you are not the intended recipient of this message, please notify the sender and delete this email without disclosing, copying, or further disseminating its contents.

4.5 Handling Special Situations

Special situations arise concerning data quality, aggregation, and employment and wage totals.

4.5.1 Data Quality

Two main issues affect data quality:

- Predecessor/successor information
- Inadequate physical location addresses

To collect employer/establishment predecessor/successor information, the EDIC staff research large worksites using the LDB and other means. The EDIC communicates predecessor/successor information to the states using the Supplemental P/S Record format. A follow-up email may be necessary to inform the states of which reporters are involved by specifying the predecessors and successors, whether or not the successor reports to the EDIC, and if the states should contact the successor.

If a worksite's physical location address changes, and the company deems that the new unit is different operationally, then the EDIC staff will assign a new RUN. In most cases if there is no change in the operations of the unit, then the same RUN is used.

The EDIC works with firms to improve the quality of their Physical Location Addresses. The EDIC staff has placed added emphasis on obtaining the physical location address of new establishment locations. All establishments with employment greater than 25 (excluding federal accounts) should have a physical location address provided by the EDIC during the first quarter that employment is reported. Others, if not immediately available, will be obtained from the employer on a lag quarter basis. Until a good physical location address is received for an establishment, the EDIC will leave the street address, city, State, Zip Code, and Zip Extension fields blank. If there is an out-of-state address or PO Box reported by the firm for an establishment, the EDIC will also report blanks in these fields.

4.5.2 Employment and Wage Totals

The EDIC does not have the ability to compare MWR employment and wages totals to those on the QCR. If there is a *significant* difference between the totals on the MWR (data summed from worksite records) and those on the QCR (on the master record), states should contact the EDIC via the EDI website using the online web-based form at <http://199.221.111.170/edi/mwrquestion.asp>. Please ensure that the form contains complete information on the discrepancy between the MWR and QCR data. The form must contain information on the employment for month 1, month 2, and month 3 of the quarter and the total wages for both the QCR and the MWR totals. If the difference is *not significant* (< 10%), states should use the numbers they think are correct and, if necessary, adjust the other numbers.

The EDIC is responsible for contacting the employer about errors or questionable data that are noted by the edits. In the case of errors affecting an entire file, the EDIC will obtain a new file from the employer and re-edit it before sending these data to the states.

After the EDIC staff completes processing for an employer, states can retrieve their data via EUSWeb and DMA and load them to their system. If the EDIC staff discovers problems with the data for an individual reporting unit, the entire firm will be held back. The EDIC only

exports data for an entire firm. The EDIC will notify states via an email message regarding reporters who do not provide useable data for a given UI, state or the entire country.

States should submit questions about data by email on the form in EXHIBIT 4A. Questions will not be taken over the phone.

4.6 Central Reporting of Federal Data

BLS is endeavoring to centrally collect the RFEW data from all federal departments and agencies. The EDIC currently receives data from the DMDC (for civilian Department of Defense), the National Finance Center (for Departments of Agriculture, Treasury, Commerce, Justice, Labor, FBI, and Homeland Security, as well as many other smaller independent agencies), the General Services Administration (for itself and many smaller agencies), the Interior Business Center of the Department of Interior (for Interior, Transportation, SSA, and many smaller agencies), the Department of Energy, the Environmental Protection Agency, Health and Human Service, U.S. Courts, the Navy Exchange, Air Force Services, and the Army NAF activities. This section of the QCEW Operating Manual will be updated as additional agencies begin to report centrally.

Once the EDIC has collected and processed federal data from these sources, it transmits the data to the states in the same manner as data for private sector employers.

Department of Defense – Appropriated Fund Activities

Each month, the DMDC in Monterey, California, provides the EDIC with a file that contains civilian Department of Defense (DoD) employment data. The monthly reporting of civilian defense employment by the DMDC meets the requirements of the CES program as well as the quarterly RFEW. The monthly file contains total worker employment and total women worker employment for each installation. These employment counts represent the bi-weekly payroll period that includes the 12th of the month. The submittal of quarterly payroll data on the third month of a quarter could result in the delayed receipt of the monthly employment data for the CES program. Therefore, the DMDC provides the quarterly payroll data with the submittal of the employment data for the following month. That is, wage data for the first quarter are provided on the file containing employment data for April, wage data for the second quarter are provided with July employment, etc. The EDIC receives approximately 10,000 records from the DMDC each month.

The EDIC processes the monthly file using a crosswalk and aggregation procedure. The EDIC uses the crosswalk to assign a UI/RUN combination to each record reported by the DMDC. Upon completion of the assignments, the UI and RUN fields summarize the data of each record. This procedure is designed to minimize, to the extent possible, births and deaths of temporary units with relatively small employment counts.

States assign UI/RUNs to each of these records during the development of the original crosswalk. The EDIC maintains the crosswalk on an ongoing basis.

For the most part, installations are assigned a NAICS code 928110 (National Security). Only selected activities are excluded from NAICS 928110. These are listed below:

NAICS Code	Title
325998	All Other Miscellaneous Chemical Product and Preparation Manufacturing
332993	Ammunition (except Small Arms) Manufacturing
336411	Aircraft Manufacturing
336611	Ship Building and Repairing
336992	Military Armored Vehicle, Tank, and Tank Component Manufacturing
445110	Supermarkets and Other Grocery (except Convenience) Stores
541330	Engineering Services
541713-541715	Research and Development in the Physical, Engineering, and Life Sciences
611110	Elementary and Secondary Schools
611310	Colleges, Universities, and Professional Schools
621493	Freestanding Ambulatory Surgical and Emergency Centers
622110	General Medical and Surgical Hospitals

Installations that include activities that fall in the above industries are separately identified. For example, a hospital at an Army base is specifically identified in NAICS 622110.

No physical location address information is available. Employment and wage data provided by the DMDC are by military service command (4-digit code). A nine-digit General Service Administration (GSA) geographical location code identifies an installation's location. The GSA location code consists of a 2-digit Federal Information Processing Standards (FIPS) state code, 3-digit county code, and a 4-digit place code combination. Reporting units for RFEW purposes are:

1. Military bases and other places with significant employment, and
2. County wide, or balance of county employment.

Generally, bases with more than 100 employees and "Other Defense" activities with large employment located within cities are reported at the place (unit) level. Data for an installation, such as an Army base, will have significant numbers of civilian Army personnel and can also have some Navy personnel, Air Force personnel, and "Other Defense" civilians (all represented by a variety of command codes). To reduce the total number of records that states need to process, all of these personnel are aggregated into one record/report for that installation. In this case, the name of the Army base will be the RUD for that record. These reporting units may well contain personnel counts that include civilian personnel of the other Armed Services and "Other Defense." Significant employment changes within a UI/RUN may be the result of employment changes within the data itself (service command) and can be identified if needed.

In addition to the above, the headquarters of the Army and Air National Guard in each state, as well as the Air National Guard bases, are reported as a separate installation. As stated before,

significant "Other Defense" activities will also be treated as an installation and reported separately.

To summarize, some installations are reported separately for industry code purposes and others for their significant employment (primarily military bases, Army, and Air National Guard headquarters). All remaining installations are aggregated to the county level so that the QCEW Program will reflect the employment and wages in the correct county. In counties that have no installations reported, the county level's summary record uses a RUD of "(county name) County." For those records that have an installation reported separately, the RUD is "Balance of (county name) County."

The aggregation process results in approximately 3,100 DoD reporting units for QCEW purposes. These levels of aggregation meet QCEW program reporting needs in an efficient manner, minimizing the number of reports. These levels also effectively meet industry specific and geographical needs.

The data furnished by the DMDC include civilian employment and wages for all branches **except** for the Exchange Services of the Army/Air Force, Navy, Marine Corps and their other non-appropriated fund activities. States should continue to solicit non-appropriated funded employment data, if these activities are not reporting separately to the EDIC. This includes:

- Army/Air Force Exchange Services (AAFES).
- Air Force non-appropriated fund activities
- Navy non-appropriated fund activities (Officer, NCO, and enlisted men's clubs, bowling alleys, golf courses, other morale/welfare/recreation activities, etc.).

Army Non-Appropriated Funds

Each month the Army Non-Appropriated Fund Central Payroll Services (NAFCPS) provides the EDIC with employment data. The data contains total worker employment and total women worker employment for each Army NAF activity. These employment counts represent the bi-weekly payroll period that includes the 12th of the month.

The following points describe the Army NAF activities employment and wages data:

1. Army NAF data includes activities related to Morale, Welfare, and Recreation activities such as Officer, NCO, and enlisted men's clubs; child care, health, welfare, and recreation activities; bowling alleys, golf courses; etc. There are approximately 100 different Army NAF Programs for which NAF provides data.
2. Army NAF Programs and Army NAF Installations are identified by two different 2-digit alphabetic codes.
3. Approximately 30 different industry classifications are assigned to the approximately 100 different Army NAF Programs.

4. Army NAF data are reported for each installation with Army NAF activities by the associated Army NAF Program. Each activity is identified by a 6-digit code consisting of the state FIPS code, the Army NAF Installation code, and the related Army NAF Program code. Not all states have installations with Army NAF activities, and each installation only has a small portion of the programs.
5. Monthly data include the total employment and the female employment counts.
6. Total quarterly wage data will normally be supplied with the reporting of the employment data for the third month of the quarter.
7. No physical location address information is available for the installations with Army NAF activities. GSA location codes consisting of a 2-digit FIPS state code, 3-digit county code, and a 4-digit place code combination will be available in the near future.

EDIC uses a crosswalk to assign a UI-RUN combination to each combination of state, Army installation, and industry code of the Army NAF records. New records for the quarter are assigned a new UI-RUN combination; consequently, an on-going maintenance of the Army NAF Crosswalk is required.

Upon completion of these UI-RUN assignments, the data are summarized for each unique UI-RUN combination. This aggregation is done to minimize the number of births and deaths of temporary units with relatively small employment counts and results in approximately 825 reporting units for CES and QCEW purposes.

National Finance Center

Each quarter, the NFC reports employment and wages information to the EDIC for the Departments of Agriculture, Treasury, Commerce, Justice, Homeland Security, and Labor, as well as many other smaller independent agencies. The EDI Center uses a crosswalk and aggregation procedure to process NFC data. Industry codes are assigned to the individual agencies within the Cabinet level Departments and to each of the other smaller agencies reported by NFC. UI and RUN assignments, which control how employment and wages are aggregated, are made for each Department/agency by industry code at the place or county/township level. The purpose of this aggregation is to minimize the number of births and deaths of records with relatively few employees.

The most detailed level of workplace identification (location) that NFC provides is by agency at the GSA place (city) within a county and in a state. No physical location address information is available from this payroll system. GSA location codes are nine-digit numeric codes. Digits 1-2 are the state code, digits 3-6 are the place (city) code, and digits 7-9 are the county code. In addition to the nine-digit location codes, NFC provides two-digit codes (total 11-digit codes) that identify the individual agencies within the Departments of Agriculture, Treasury, Commerce, Justice, Homeland Security, Labor, and each of the smaller independent agencies. The two-digit agency codes determine the industry classifications within the Departments and for each of the independent agencies. To develop the crosswalk initially, each state assigned UI/RUNs to each of the 11-digit codes for their respective state. The EDIC currently maintains the crosswalk.

Employment and wages of agencies within Agriculture, Treasury, Commerce, Justice, Homeland Security, and Labor, are summarized by industry code at their Department level. For the other smaller independent agencies, data are summarized at their respective agency levels. That is, no further breakouts by industry code are provided. Depending upon the magnitude of employment, RFEW data are provided to states for each Department and independent agency at either the place (city) or county level. Approximately 24,000 records are received each quarter from the NFC. The aggregation process results in approximately 17,000 agency/industry records for QCEW purposes.

4.7 Employer Reporting of MWR Data Directly to States

Submittal of MWR Data Directly to States

Companies that report MWR data on transmittable media and that have multiple worksites within only one state may report their data directly to their state agency.

As with central reporters, testing of tapes/diskettes/CDs/electronic file should be performed before an employer is authorized to transmit MWR data via portable media on a regular basis. State systems personnel should perform initial acceptance testing for the first quarter in which the employer reports via portable media. The record format should be verified as one of the input file formats in Appendix N and the data should be compared to the hard copy MWR received concurrently. Thus, data should be dual reported during the testing phase. In addition, the employer's UI Account Number format on the test file should be verified.

For each quarter following the initial testing quarter, the state should send a notification reminding the employer that the file is due. (See EXHIBIT 4B for a sample letter.) Note that the letter should mention the next available RUN for the employer. This reminder notice will replace the hard copy of the MWR, which is usually sent to multi-establishment employers each quarter. For the first quarter of each year, an "informed consent" cover letter should be sent to the employer. (See EXHIBIT 4C for a generic sample letter and EXHIBIT 4D for special instructions concerning the generic letter.)

Therefore, the state should prevent the mailing of the MWR to those companies who report via magnetic media.

State Processing of MWR Magnetic Media Data Submitted Directly

The standard state processing systems have the ability to suppress the mailing of printed MWR forms for employers that have been authorized for magnetic media submittal. However, the states should still send these employers reminder notices and follow-up notices for delinquent files.

States should be able to determine if data for more than one state are present on the employer's file. If this is the case, only that state's data should be loaded into the system.

Files should be checked immediately upon receipt. States should run timely micro edits on the MWR data, as is done with data from the hard copy reports. If there are any obvious, serious problems with the file, states should contact the employer immediately and ask for a revised file.

Assignment of RUNs

Normally, states accept MWR electronic/magnetic media data from those employers who store and provide the state-assigned RUNs. (However, states may make exceptions to this by creating crosswalks for certain employers.) In obtaining RUNs for new worksites, the employer is permitted to assign what appears to be the next available RUN to a new worksite. Employers should be instructed to assign the next available number (in sequence) and not to reuse RUNs. States should check for new and invalid RUNs. States must start their initial assignment of RUNs for a new MWR with 00001. In this manner, it is easier for employers to determine the next RUN when a worksite opens within a state. Invalid RUNs include duplicate RUNs and RUNs that were discontinued. If state personnel determine that an employer used an inappropriate number, they should contact the employer and request the appropriate change. One approach to ensure proper assignment of RUNs is to use the reminder letter or notice mentioned above to identify the next available RUN to be assigned to a new worksite.

4.8 MWR Web Internet Data Collection

Data Collection by MWR Web

BLS also developed a central collection point for the MWR and RFEW on the Internet to provide means for reporters to report their quarterly data. Each quarter, a computer-generated email message is sent to each registered respondent reminding them it is time to report their data. Follow-up reminders are sent throughout the collection quarter to respondents who have not yet submitted data. Respondents initially access the BLS Internet Data Collection Facility with a temporary account number and password, which is printed on the MWR paper form either by the State or the Print Contractor. Once the respondent has registered their IDCF account, they are given a permanent USER ID and are asked to set their password. A User ID is assigned to the respondent by the IDCF to access all of the BLS surveys for which data are submitted. Once respondents have navigated through the IDCF “gatekeeper,” they select the MWR survey and click on the UI account to enter their data. Respondents who do not provide complete data for two consecutive quarters are returned to paper reporting. The Division of Business Establishment Systems (DBES) may notify states of a respondent’s failure to provide complete data by an email message. States may also notify BLS if they wish to exclude an MWR Web respondent from web reporting by sending email to mwr.helpdesk@bls.gov.

Firm Solicitation

BLS staff solicits firms for web reporting who meet all of the following criteria:

1. Employer is not an EDI reporter, and
2. Employer is an active multiple location employer with at least one quarter of historical data

3. The employer is not an excluded State or Local Government reporter. This exclusion is determined by each State.

The Solicitation Process for States and BLS:

1. States generate the “List of Actives” file and upload it to DBES. This file identifies all eligible MWR reporters in the State. DBES uses this file to produce the temporary account number and password for all eligible MWR accounts that are not current MWR Web reporters.
2. DBES sends a Solicitation Request File (SRF) to States. The SRF is important because it contains the solicitation information that needs to be printed on the MWR forms so that respondents can access the web system.
3. States produce the State Historical File (SHF) and send it to BLS by the established due date in the MWR Web production calendar. It is vital that this file is uploaded to the web system. Without the SHF data respondents will not be able to access the web system.
4. The SHF is audited by BLS to determine if any issues with the file exist. If so BLS asks the states to provide explanations for any missing data, and/or upload a new SHF if needed.
5. States and the MWR Print Contractor mail the solicited firms their paper MWR or RFEW forms with a temporary User ID and password printed on it. Employers not wishing to report on the web may fill out and return the forms to their respective states. States should mail MWRs according to their normal processing times. However, states should not mail forms to employer UI accounts that are being solicited for the MWR Web until they are notified the MWR Web is ready to begin the collection process. This will prevent employer frustration when they try to log on to the IDCF for the first time.

Registering

Respondents must first register with the IDCF Gatekeeper before entering data. Respondents are provided with the URL on their MWR form IDCF home page (<https://idcf.bls.gov/>).

Respondents must then enter the temporary account number (User ID) and temporary password provided on their paper MWR/RFEW. Respondents are prompted to update their contact information to include their email address and create a permanent personal password. IDCF will then generate a permanent IDCF account number to allow access to all of the BLS surveys administered to the selected firm.

As a part of each week’s transmittal BLS sends a Confirmed Register File to the States. This file contains a list of the accounts that have signed up for MWR Web during the course of the collection cycle thus far.

NOTE: If a respondent has more than one MWR form to complete, they can add additional MWR accounts to their IDCF login by selecting “add an additional account”. After entering the temporary ID and password from the additional MWR forms, they will be able to access all of their reports with a single ID and Password.

Entering Data

Once respondents select the MWR survey, they will be directed through the system as necessary. The respondent will enter monthly employments and total quarterly wages for existing worksites and add new worksites and corresponding employment and wages as necessary. They can also indicate which worksites should be closed or sold. Respondents can indicate that a worksite needs to be removed by clicking on the “remove” button. Respondents will then be directed to select a reason they are removing the worksite which will correspond to the applicable comment code. Finally the respondent is asked to report any employment or wages that the worksite had during the quarter.

Before quarterly MWR data are submitted, a summary sheet appears asking the respondent to verify that the employment and wages match their state QCR. In addition, the system also allows the firm to notify their state of the following reporting situation(s):

- If their company has been sold, merged, or reorganized, or
- If their company has acquired another company, or
- If their company has opened a new UI account

Respondents who fail to report for two consecutive quarters will revert back to paper reporting. These accounts are recognized when the MWR Web system identifies that no data have been reported a second time. Before doing so, an automated email will be sent to them reminding them of their obligation to report, and inform them that failure to do so will result in paper mailings.

Quarterly MWR/RFEW data that has been provided through the MWR Web is fed back to the states through the Collected Data files. The Collected Data files are provided to states in weekly transmittals during the quarterly collection cycle. States are able to access this data through EUSWeb or DMA. State staff should use their state processing system to load their Collected Data files directly to their QCEW micro database.

At the end of the Collected Data file, there is a field which will contain an indicator to continue MWR Web reporting or to change back to paper reporting. This indicator acts as an on/off switch for printing and mailing operations. This method is the only communication between BLS and the states when a respondent is returned to paper reporting.

Additional information on the MWR Web data collection is available on the StateWeb.

Chapter 5 – Handling Changes in Reporting Configuration

In FY 1995, Congress provided funding to BLS to begin creation of a database using QCEW micro level data that would allow for the longitudinal analysis of business establishments. The Longitudinal Database (LDB) tracks establishments over time and links them from quarter to quarter. The resultant longitudinal establishment data allow for high-quality measures of job creation, job destruction, and job reallocation within and between industry sectors, regions, employment size classes, wage size classes, and establishment age classes. For policy makers and business forecasters, who rely heavily on economic indicators, information regarding job flows and the births and deaths of establishments (hereafter referred to as “births” and “deaths”) is of great interest.

The quality of longitudinal data is dependent on accurately distinguishing between continuous and discontinuous business establishments. Because of the importance of keeping establishment information continuous, this chapter discusses what to do when an establishment's UI Account Number and Reporting Unit Number – its reporting configuration – changes.

----- Contents of Chapter 5 -----

- 5.1 Predecessor/Successor Relationships
- 5.2 One to Many or Many to One
- 5.3 Successors with Code Changes
- 5.4 Successors Reporting at a Different Level
- 5.5 Breaking Out (Disaggregating) New Multiple Worksite Reporters
- 5.6 Consolidating Multiple Worksite Reporters
- 5.7 Tracking Establishments that Change UI or Reporting Unit Numbers in the LDB
 - 5.7.1 LDB Linkage Process
 - 5.7.2 Updates and the Linking Process

5.1 Predecessor/Successor Relationships

The BLS uses the term Predecessor/Successor Relationship to describe situations where employment or assets are transferred from one business establishment to another. The successor (the new owner of an establishment) performs similar operations to the predecessor (the previous owner of an establishment) using some or all of the predecessor's employees. These operations are frequently, but not necessarily, performed at the same location as the predecessor. In many states, the QCEW definition of a predecessor/successor situation does not match the legal Unemployment Insurance (UI) definition of an ownership transaction. State editors are encouraged to research Predecessor/Successor laws in their states.

There are many cases where businesses are sold to existing accounts and the data are merged together. In other cases, only part of the operation is sold, and a portion of the original business continues to function. Do not assume that the successor account never existed before or that the predecessor account ceases to operate. Editors should take care when determining if and when data should move from one employer (one UI account) to another.

In cases where a new employer is located in the same site as an out-of-business account, it should not be assumed that the new account is the successor. For example, it would be inappropriate to assign this relationship for stores in shopping malls. As one retailer ceases operations and the site is leased to another retailer, there is usually no relationship between the old and new establishments.

Predecessor/successor information in the QCEW program is reported using the following fields:

- Predecessor UI Number
- Predecessor Reporting Unit Number
- Successor UI Number
- Successor Reporting Unit Number

Establishments are uniquely identified by their UI Account Number and Reporting Unit Number (RUN) within a state. The UI Account Number is a 10-digit identifier assigned by the State Workforce Agency (SWA) to identify employers covered under state UI laws. UI Account Numbers are assigned to employers who have one or more establishments. The Reporting Unit Number (RUN) is a 5-digit number used to uniquely distinguish worksites of a multi-unit UI account. Establishments sometimes change UI/RUNs due to changes in ownership or changes in reporting level. Changes in reporting level generally take two forms:

1. An employer previously reporting multiple locations as a single-unit account disaggregates the consolidated unit and begins reporting those locations on a Multiple Worksite Report (MWR).
2. An employer whom the state has set up as an MWR reporter (a multi-unit account) is no longer willing to provide disaggregated data. The multi account must be consolidated into a single.

These cases are referred to respectively as breakouts and collapses.

Records with a UI/RUN change appear to be births or deaths unless there is a predecessor/successor relationship/link reported between the old and new UI/RUN. The basic link used to identify a continuous unit is the Predecessor UI Account Number or the Successor UI Account Number. Since many UI accounts are reported using multiple records (for their multiple establishments or worksites), Predecessor or Successor RUNs are also needed to link at the establishment level.

Some states have been very successful in identifying predecessor and successor relationships, while other states have significantly less information available to make these determinations. Predecessor and successor account information should be extracted from UI tax files where available. If the state does not maintain worksite information and Reporting Unit Numbers on the tax file, the predecessor and successor Reporting Unit Numbers should be zero-filled initially, until state staff can follow up to verify or correct them. (Issues related to extracting predecessor and successor information are also discussed in Section 7.3.)

When researching predecessor/successor links on the tax file, you may find non-extracted information that would be useful when examining the data. This may include transfer codes, transfer dates, merger information, successor suffix codes on the account number, etc. Wage records are another possible source of predecessor/successor information. Stand-alone systems exist such as the Wage File Creator for each state processing system that uses standard LEHD formatted wage record data for two quarters at a time. These systems generate summary and matched wage record data without any PII (Private individually identifiable) data that can be used in the state systems to detect possible predecessor/successor linkages. See StateWeb for more information on these stand-alone systems and the LEHD format.

5.2 One to Many or Many to One

The purpose of Predecessor and Successor UI and RUN coding is to identify establishments as continuous and minimize spurious establishment births and deaths. These cases are not limited to units that have changed ownership or UI number, but may also include UI accounts that change Reporting Unit Number configuration (i.e., the breakout or consolidation of units).

Whenever a one-to-one relationship is established, the Predecessor UI and RUN fields should be coded with the UI and RUN numbers under which the unit was previously reported. Similarly, the Successor UI and RUN fields of the Predecessor record should be coded with the UI and RUN numbers under which the account is currently reported. For example, an establishment that changes owners twice in simple one-to-one transactions could be reported as follows:

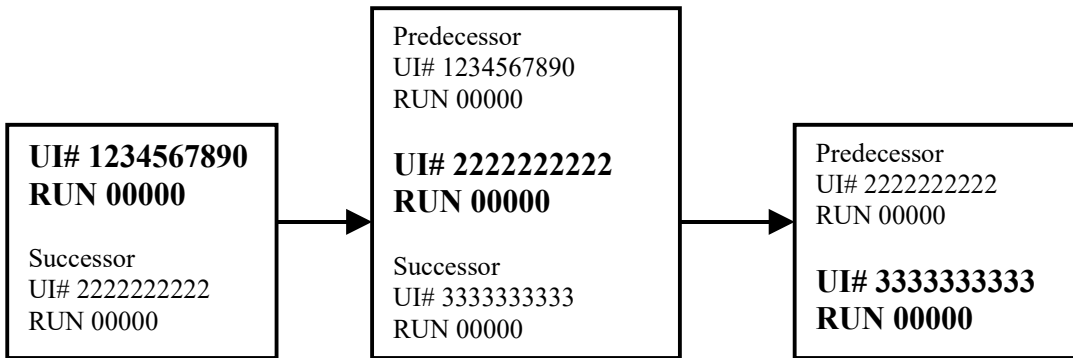

Whenever a many-to-one Predecessor/Successor relationship exists, all predecessor UI and RUNs should be identified in the Successor account, and the Successor UI and RUN should be assigned to each Predecessor UI and RUN.

**Example 1: Many-to-One.
No Unique Predecessor to Put on Consolidated Unit**

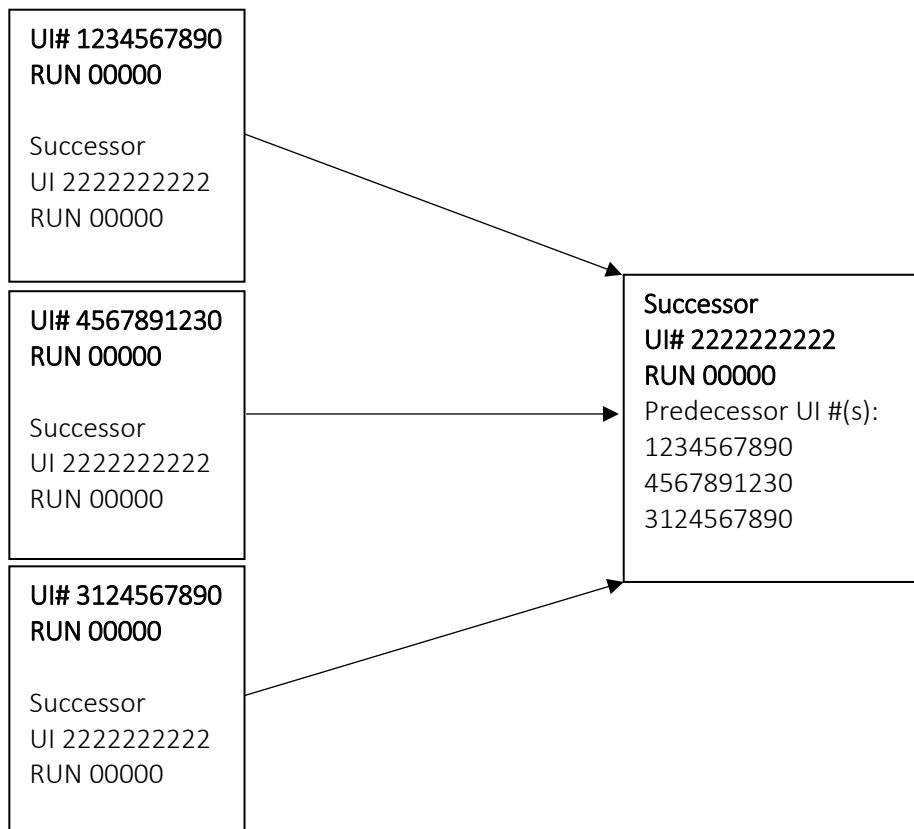

Similarly, whenever a one-to-many predecessor/successor relationship exists, it is possible to identify all UI/RUN(s) as successors. Also, the UI and RUN of the consolidated unit are inserted in the Predecessor UI and RUN fields of all the newly formed subunits.

**Example 2: One-to-Many.
No Unique Successor for the Unit Being Split.**

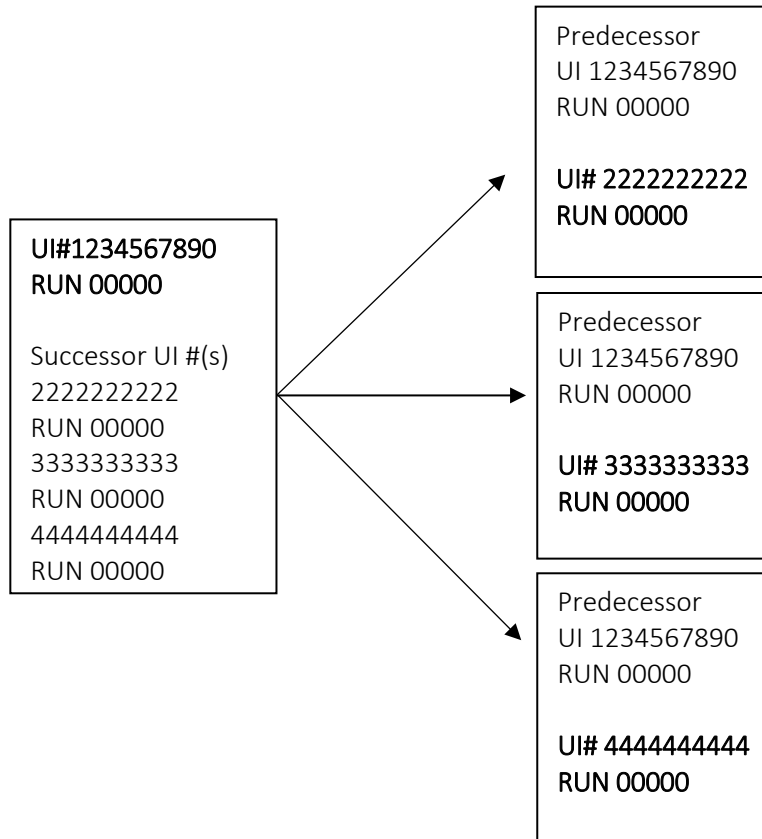

When data for a multi-unit employer are broken out for the first time, the unit for which data are being broken out (i.e., the original, aggregated record) should contain the UI Account Number of the new worksite records in its Successor UI field and the successor RUNs should be entered in the successor RUN fields.

Example 3: Initial Break Out For A Multi-Unit Employer

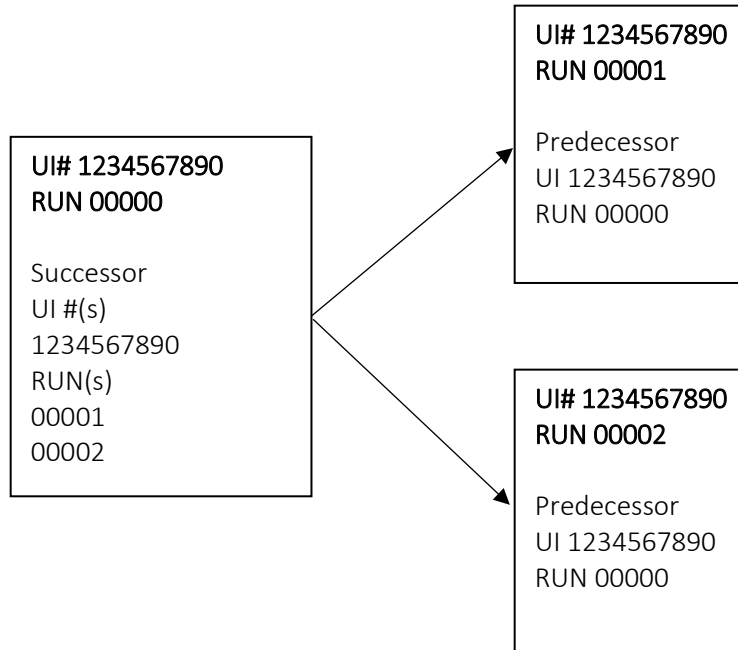

When a multi-unit employer is collapsed (e.g., because the employer refuses to report on the MWR), the Successor UI/RUN fields of each predecessor worksite record would be coded with the UI/RUN of the successor since there is only one UI Account/RUN to point to as the successor.

For cases involving the merger of several UI accounts either in whole or in part, it is usually possible to assign unique Predecessor UI/RUNs to each of the establishments being reported on the MWR of the re-formed multi establishment reporter. In the case of multiple UI Accounts contributing to a newly formed multi-establishment in which the employer refuses to report a MWR, each establishment shifting into the collapsed unit must carry the UI and RUN of the record from which they were shifted. In addition, the Predecessor UI Account Number and RUNs should be included with the new reporting unit.

**Example 4: Merger of Several UI Accounts.
Successor Not Willing To Report as an MWR.**

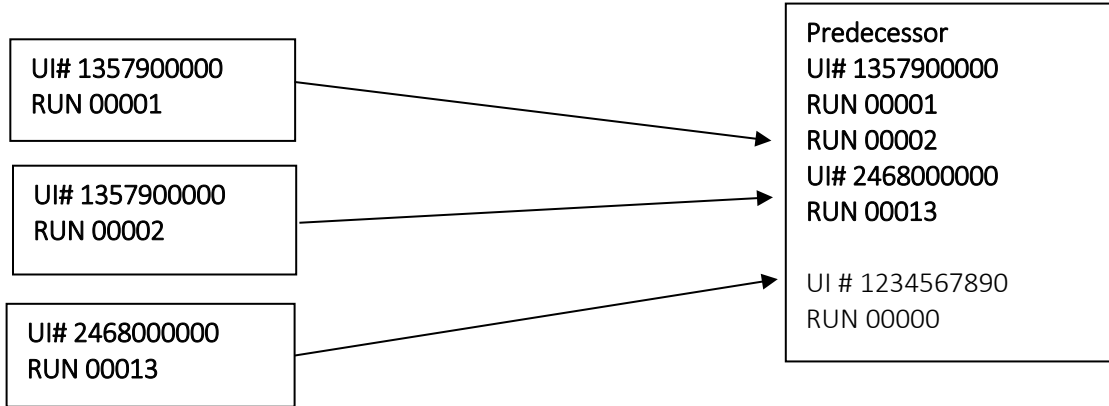

To consider this same example again, it would be better to report unique Successor UI/RUNs on the records that contribute to the new record (that is, on the predecessors). This gives a more accurate link:

**Example 5: Merger of Several UI Accounts.
Each Predecessor Matched To the Successor.**

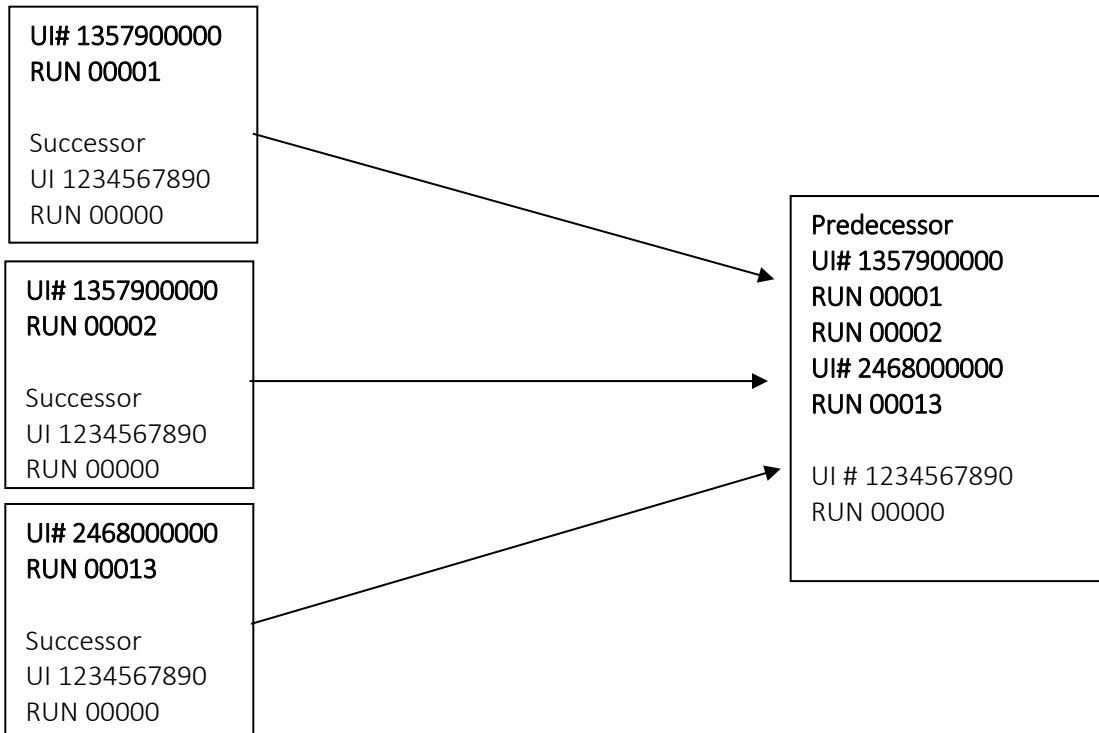

Changes Within the Same UI Account

Records in UI accounts that change-reporting configuration (by breaking out or consolidating reporting units) should also be assigned a Predecessor or Successor UI/RUN. When data for a multi-unit employer are broken out for the first time, each newly disaggregated subunit should repeat the UI Account Number and RUN of the previously aggregated unit in the Predecessor UI Number and Predecessor RUN fields. When a multi-unit employer is collapsed (e.g., because the employer refuses to submit the MWR), the subunits in the prior quarter must be assigned the appropriate UI/RUN of the collapsed Successor in their successor code fields. In addition, the newly combined record should include the UI Account Number of the previous multi-unit account in its Predecessor UI Number field and the Predecessor Reporting Unit Number(s) should be added to the collapsed successor's Predecessor fields.

Summarized below are the principals involved in assigning predecessor and successor codes when there is not a unique one-to-one relationship.

1. When there is more than one reporting unit to point to as the predecessor of the unit, the UI and RUN of the successor should be inserted in the Successor UI/Successor RUN fields of each of the multiple Predecessor Reporting Units (in one or more UI accounts). (See Example 8.)
2. Similarly, when there is more than one reporting unit to point to as the Successor of a unit, specific Successor RUNs should be assigned. (See Example 6.)
3. When there is more than one UI Account Number to point to as the Predecessor of a unit, specific Predecessor UI Account Numbers should be assigned. (See Example 10.)
4. Similarly, when there is more than one UI Account Number to point to as the Successor of a unit, specific Successor UI Account Numbers should be assigned. (See Example 2.)
5. The situations described in #1 and #3 above can be fully identified by assigning the Successor UI and RUN to each of the multiple Predecessor reporting units (in one or more UI accounts). Therefore, it is better to assign Successor UI/RUNs to provide a unique link.
6. The situations described in #2 and #4 above can be fully identified by assigning the Predecessor UI and RUN to each of the multiple Successor reporting units (in one or more UI accounts). Therefore, it is better to assign Predecessor UI and RUNs to provide a unique link.

See the examples at the end of this section for specific cases of predecessor/successor coding.

Notes

Note A): Predecessor codes should still be assigned for reporting changes (such as a breakout or collapse of worksites) within an existing UI account. The Predecessor UI number should be the same as the UI Account Number field.

Note B): The availability of this information might not reflect the exact quarter the change occurred. While BLS strongly prefers the timely reporting of these fields, the Predecessor/Successor fields should be assigned when the information becomes available.

Note C): There may be cases where a new multi worksite is opened (a birth). In these instances, the new record should not have a Predecessor UI/RUN. Creating a new record in this case reflects an economic event rather than a reporting change. In the case where a single-unit UI account becomes a multi-unit UI account because of the opening of a new location, predecessor and successor codes should be assigned to the original location so that it remains a continuous establishment despite its change of RUN.

Note D): Predecessor and Successor UI/RUNs are much more useful on single-unit or subunit records (MEEI 1, 3, 4, 5, or 6) than on master records (MEEI 2). This is because a master record never identifies a single establishment; it always represents several establishments (worksites) within the UI account.

Predecessor/Successor Situations

[Note: Left side = prior quarter, right side = current quarter reporting]

Example 6: Further Breakout of Worksites in a Multi-unit Account

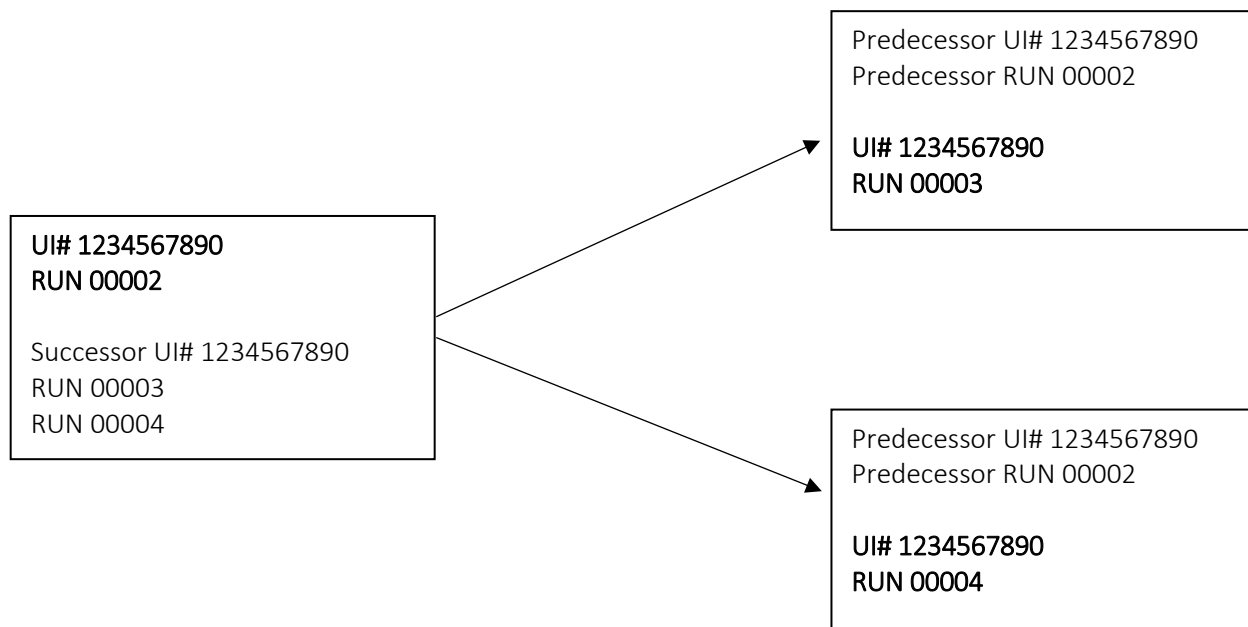

**Example 7: Consolidated Predecessor/
Successor Provides Breakout**

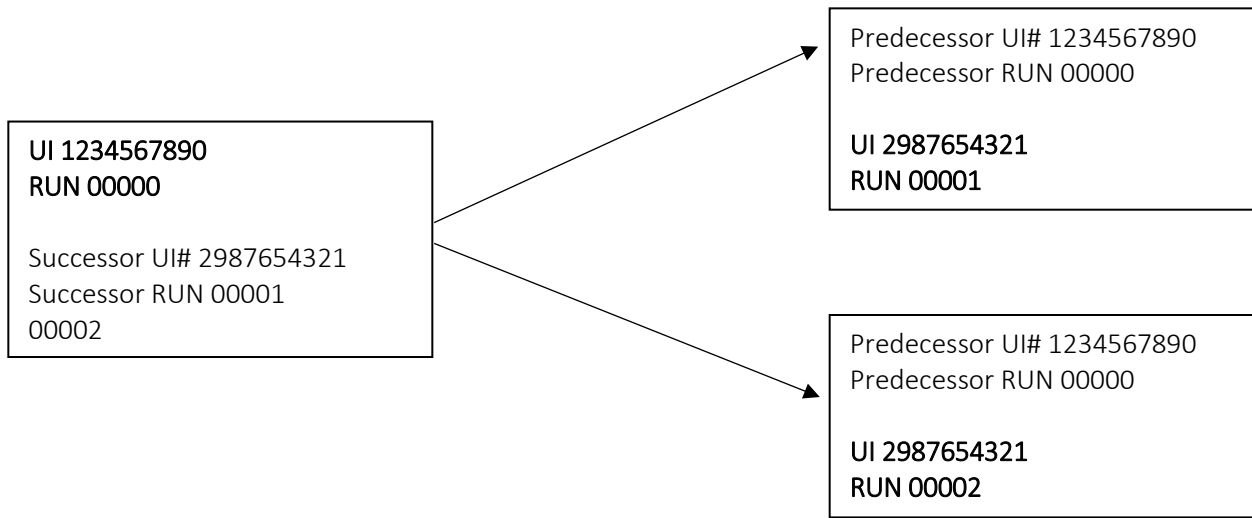

**Example 8: Multi-Unit Predecessor/
Successor Does Not Provide Breakout**

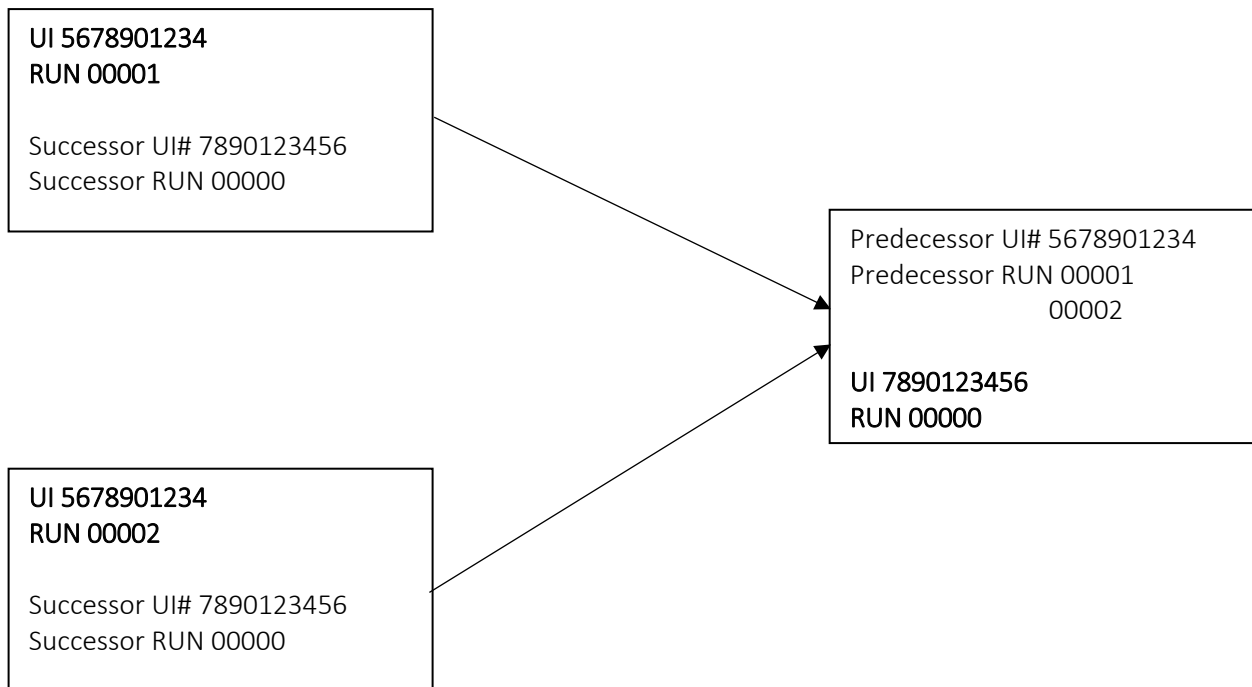

**Example 9: Multi-Unit Predecessor Sells to Many Successors/
Each Successor Provides Breakouts**

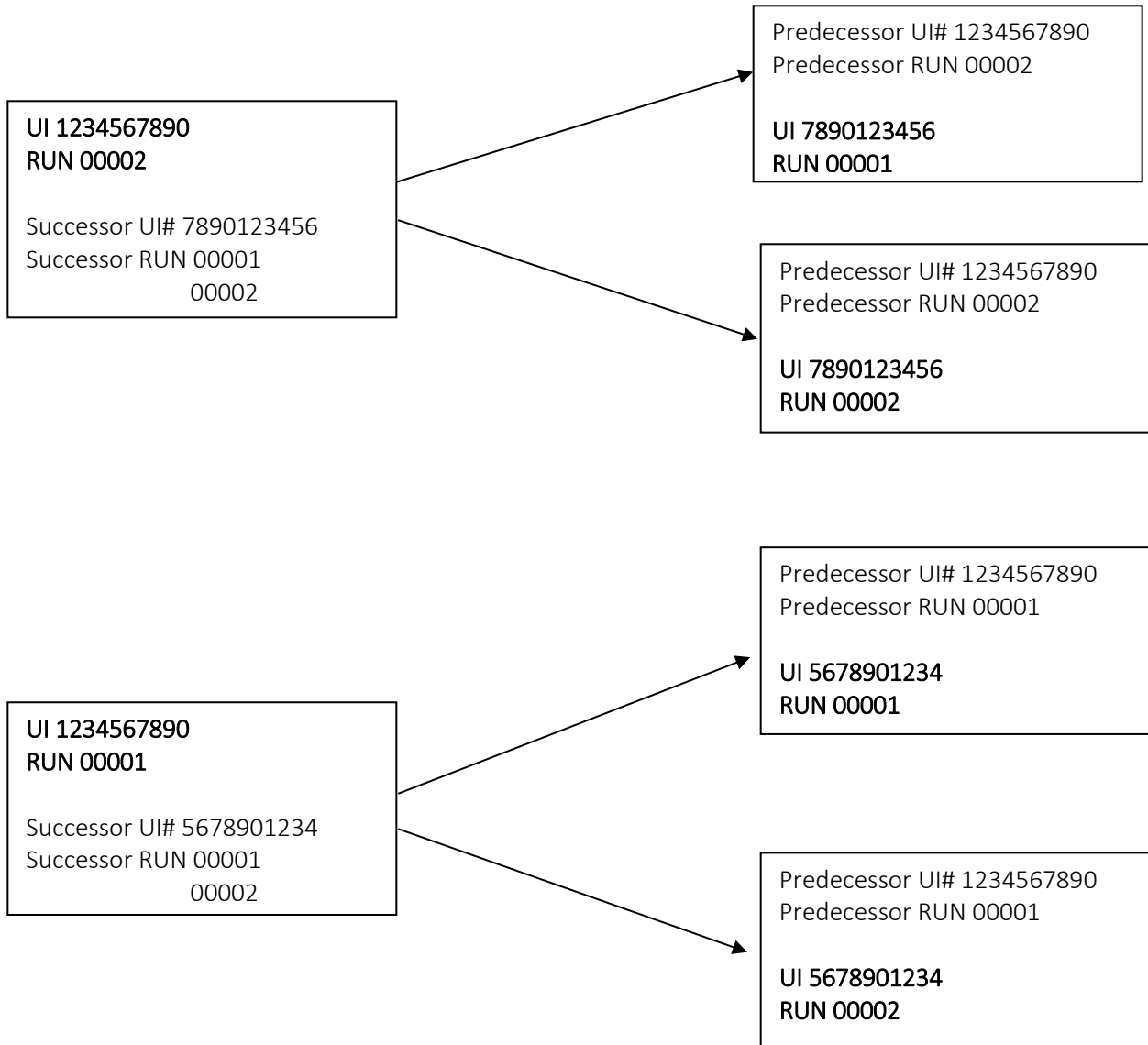

Example 10: Many Predecessors with Different UI Account Numbers Collapsed into One Successor Account

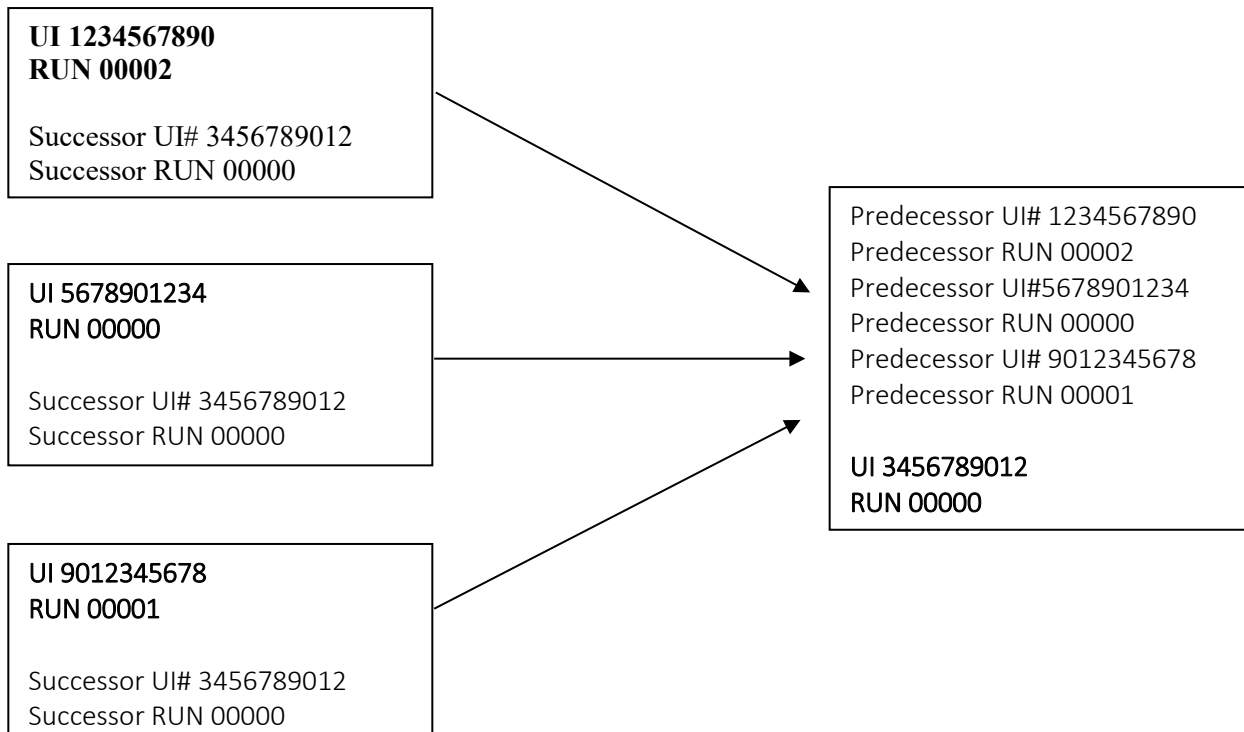

Example 11: Multi-Unit Establishment Collapses into One Unit

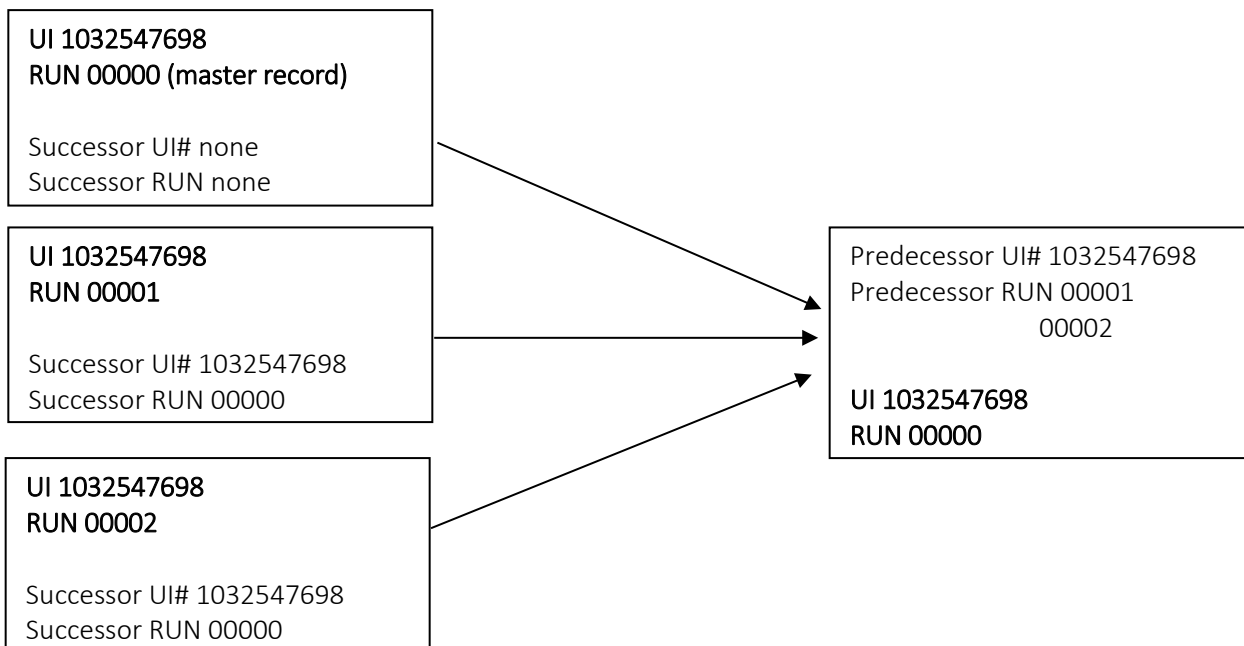

Example 12: Multi-Unit Establishment Breakout into Two Units

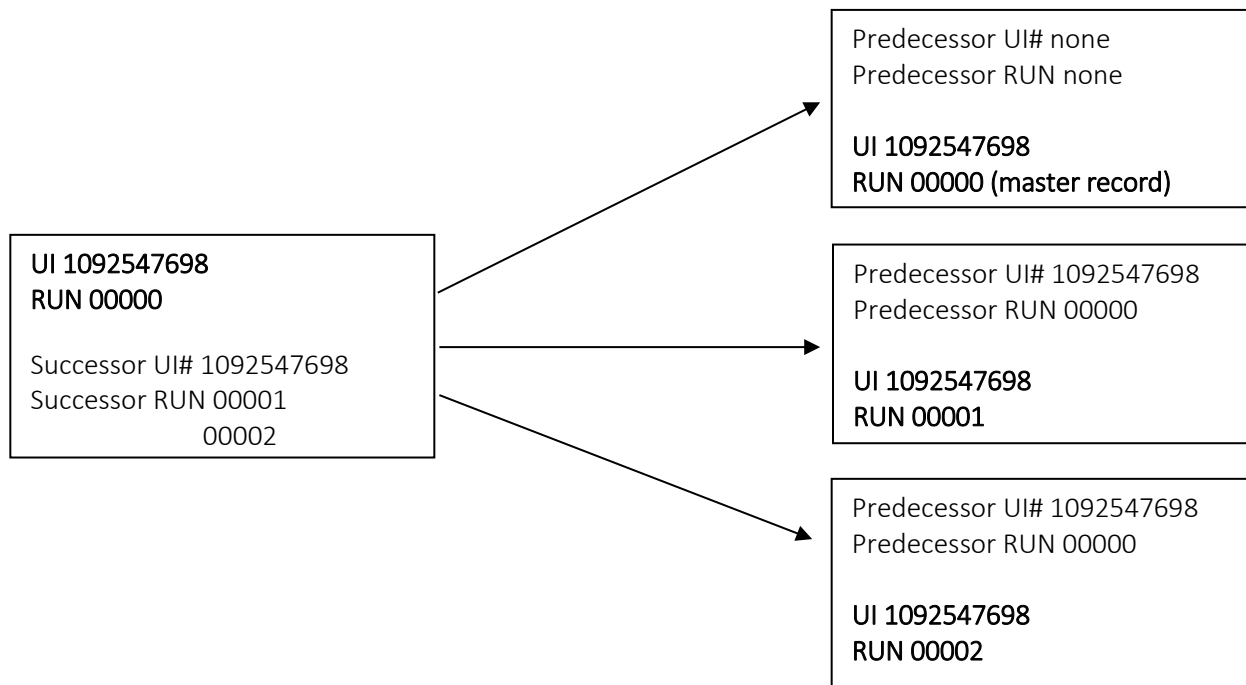

5.3 Successors with Code Changes

A substantial number of determinations are made each quarter for subject employers who are successors to active accounts, and the majority of these determinations are for small units. When new nature-of-business information is obtained for each of these employers, the codes are determined accordingly. The problem arises as how best to handle those cases that involve changes from the codes of the predecessors. This section discusses this problem under the assumption that the level of reporting for the acquired unit(s) does not change.

If the unit had 25 or fewer workers in the last month before or the first month after the change of ownership, assign the industry and geographic codes that correspond with the **successor's** activity and location. This is effective with the date of the change of ownership or when information of the change becomes available, whichever is later, regardless of whether the new activity or location represents a change from the previous codes. No investigation is necessary to determine if the prior codes were different, and no reporting of a noneconomic code change is necessary. This should substantially reduce the workload of checking codes for these small successors.

Codes for units with more than 25 workers in the last month before and the first month after the change should be handled as follows:

- (1) If the activity or location of the successor unit is the same as the predecessor's industry and geographic (county or, for some states, township) codes, assign the same codes to the successor, effective immediately. There will, of course, be no code change to report.
- (2) If the activity or location of the successor is not the same as the predecessor's industry and county (or county/township) codes, then:
 - a) If the successor unit uses the predecessor's facilities for a totally new business (as determined by industry code) or moves to another county (county/township), and this change takes place in an open review quarter, the change in code is an economic code change. The new code or codes should be put into effect with the change in ownership, assuming that this information is available in time to be included in the appropriate EQUI file. Assign the Economic Code Change Indicator of the successor, using the value corresponding to the code or codes that change. The Economic Code Change Indicator is described in Appendix B.
 - b) If when processing the predecessor/successor transaction it is discovered that the predecessor has changed their economic activity to that of the successor, then create a breakout with the two establishments keeping the predecessor and successor in their respective codes. In first quarter, add the code change of the predecessor to the CCS and collapse the two worksites if the employer refuses to provide a MWR. See [Section 11.5.3](#) for reference.

The following diagram gives an example of noneconomic code changes to industry and county on the successor record, showing the correct assignment of the Old fields.

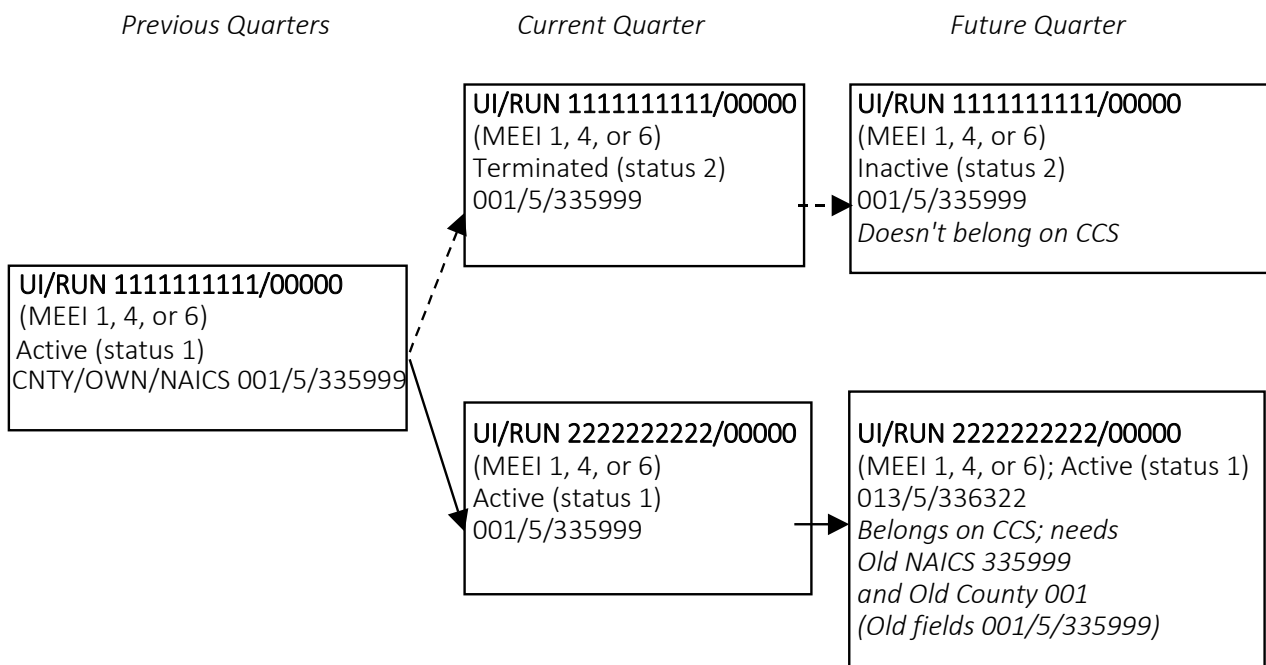

- c) If the predecessor had the same activity (industry) and location (county or county/township) as the successor, but the industry or county code was in error when previously assigned, the successor should be given the old (incorrect) codes until the beginning of the next year. Then the change to the new codes should be handled as a noneconomic code change. Use the procedures described in Section 11.5.3 so that the successor is placed on the CCS.

However, if the change to the new UI account takes place during first quarter and the first quarter EQUI has not yet been submitted, the predecessor's codes may be corrected back to the beginning of the current year and the noneconomic code change reported accordingly. The predecessor record in this case belongs on the CCS. In this situation, the predecessor and successor are both active during first quarter. This can also occur during the first quarter cleanup and the second quarter processing. Code changes after second quarter must be held until the next first quarter since they cannot be included on the current year's CCS. The predecessor's End of Liability Date and the successor's Initial Liability Date both fall within the quarter.

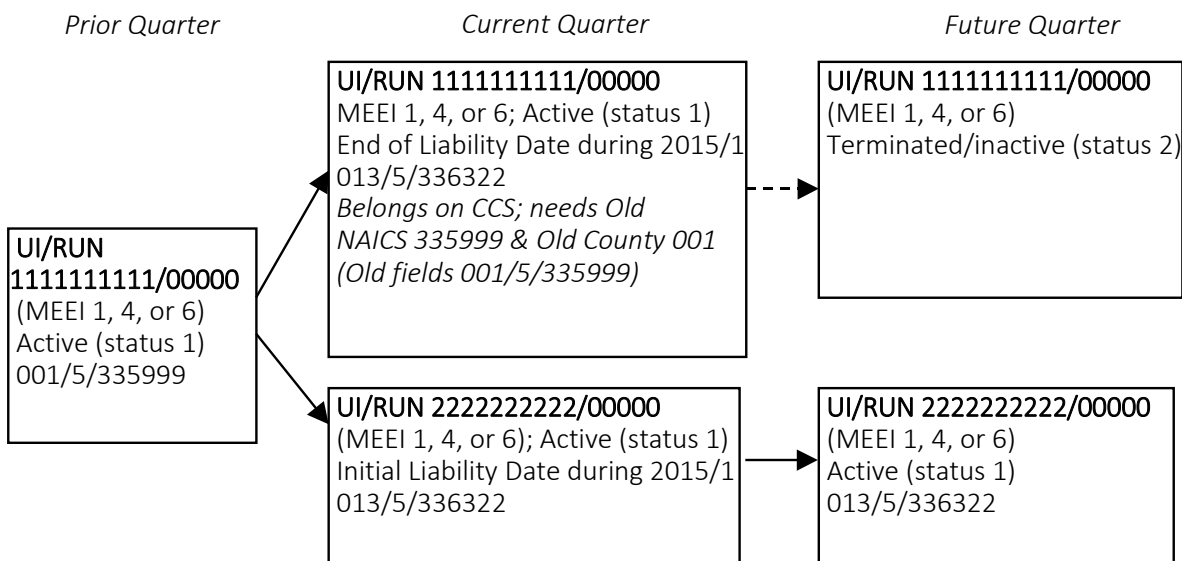

Suppose the change to the new UI account took place with the beginning of first quarter and the predecessor becomes inactive sometime during the preceding fourth quarter (or at the end of fourth quarter). If the first quarter EQUI has not yet been submitted, the successor should be assigned the appropriate data elements, including Old fields, so it will be included on the CCS. This can also occur during the first quarter cleanup and the second quarter processing.

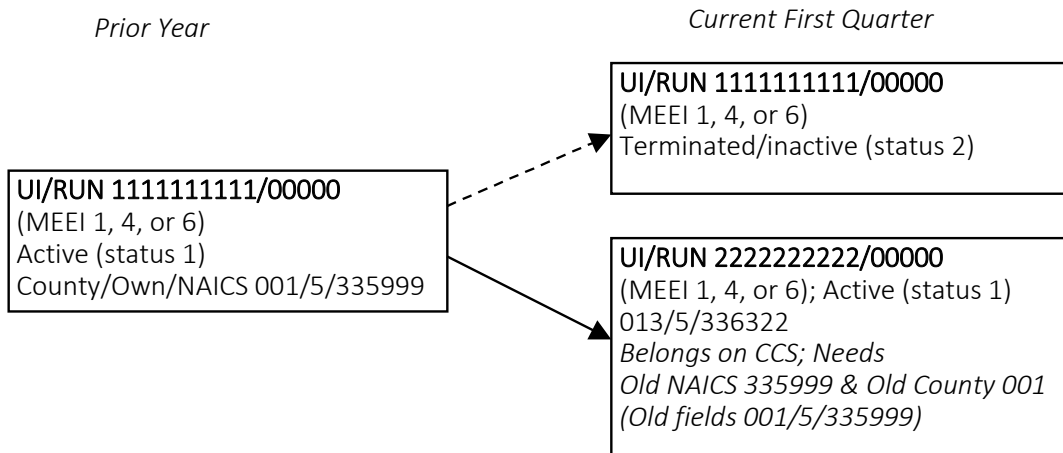

Section 5.5 describes the procedures for handling industry or geographic code changes resulting from new breakouts of multi-establishment employer reporting units. Although such breakouts include reporting in predecessor and successor fields on the EQUI file to maintain continuity of records over time, the procedures for industry and geographic code changes in successor relationships described in this section do not apply to such breakouts.

5.4 Successors Reporting at a Different Level

Many predecessor/successor transitions involve multi-unit accounts. Either the predecessor UI account, the successor account, or both may have multiple worksites in the state. Sometimes the successor (the employer with the successor UI account) is not willing to continue reporting disaggregated data on a MWR and the successor account must be collapsed. Sometimes the successor is willing to begin MWR reporting, and can be handled as a new breakout. Sometimes the successor continues as an MWR reporter, but will provide the data at a different level of aggregation. The more frequently occurring scenarios are illustrated in this section.

1. A Successor That Becomes an MWR Reporter

In this hypothetical example, the business changes hands beginning in first quarter and the new employer (under a new UI account number) agrees to report data separately for each worksite. The Old fields on the subunit records of the successor account (UI Number 3333333333) should match the fourth quarter codes of the predecessor (of UI/RUN 2222222222/00000). This resembles the first example in Section 5.5, the simple breakout introduced in first quarter.

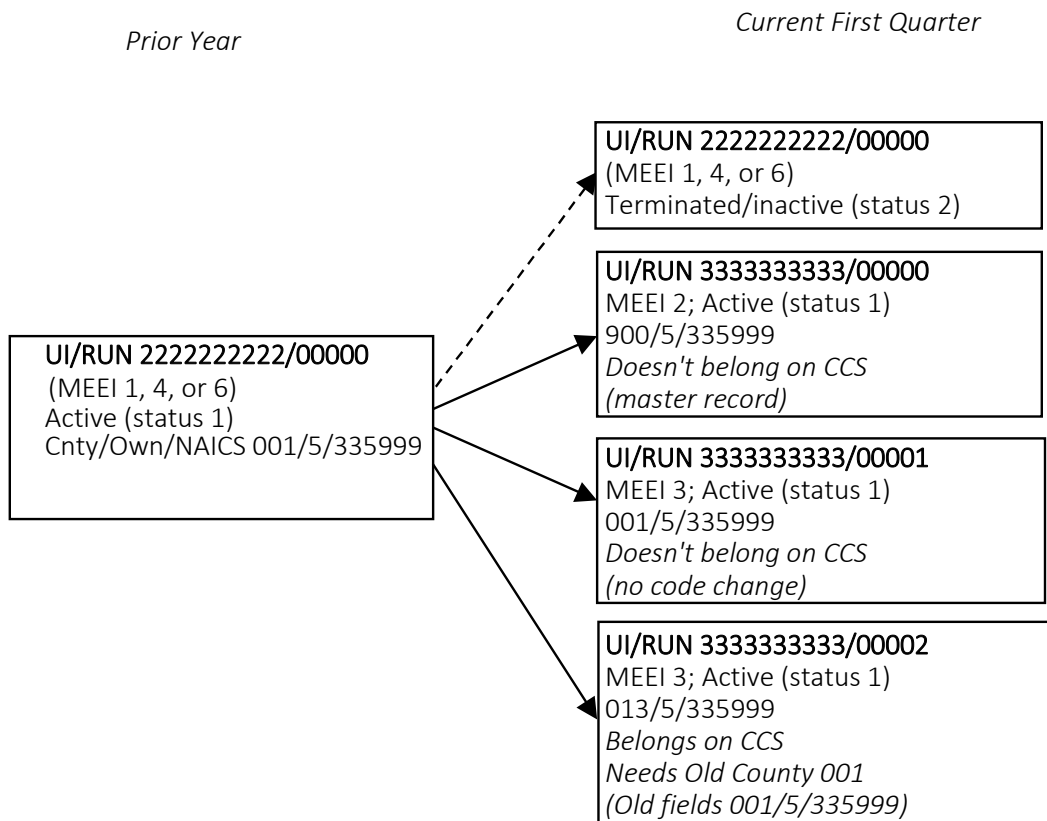

2. A Successor That Discontinues MWR Reporting

In this example, the business changes hands beginning in first quarter and the new employer (under a new UI account number) will not provide disaggregated data, this is, will report only on the Quarterly Contribution Report (QCR). In other words, the successor collapses into a single-unit account. The records that belong on the CCS are the inactivated subunits of the predecessor, but only those subunits that were formerly reported with different area or industry codes than the successor.

This resembles the example in Section 5.6, the multi that collapses in first quarter. The Old fields on the inactivated subunits are identical to their classification codes in fourth quarter, while their first quarter classification codes must be the same as the codes on the active successor record (the MEEI 4 record in the new UI account).

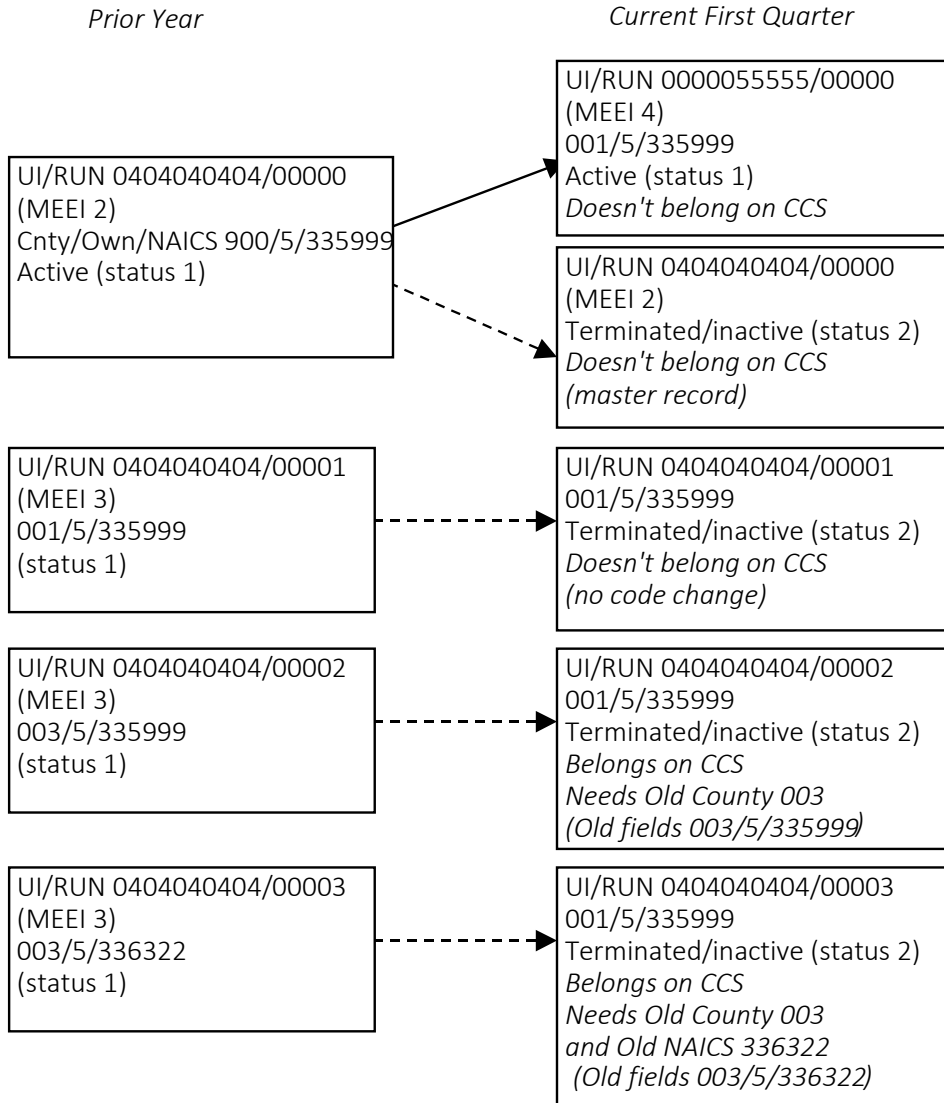

3. A Single Establishment Acquires More than One Single Establishment.

A single-unit account (UI 5555555555) stays in business but acquires other UI accounts beginning with first quarter. This employer agrees to report worksite data separately on the MWR, thus becoming a multi. The predecessors for the newly acquired worksites are: (1) a multi that was reporting as a single (UI 6666666666), and (2) a single with an incorrect county code (UI 7777777777). As with other cases considered in this section, the records that belong on the CCS were not active in fourth quarter under the same UI/RUN. Their Old fields should match the fourth quarter classification codes of their predecessors.

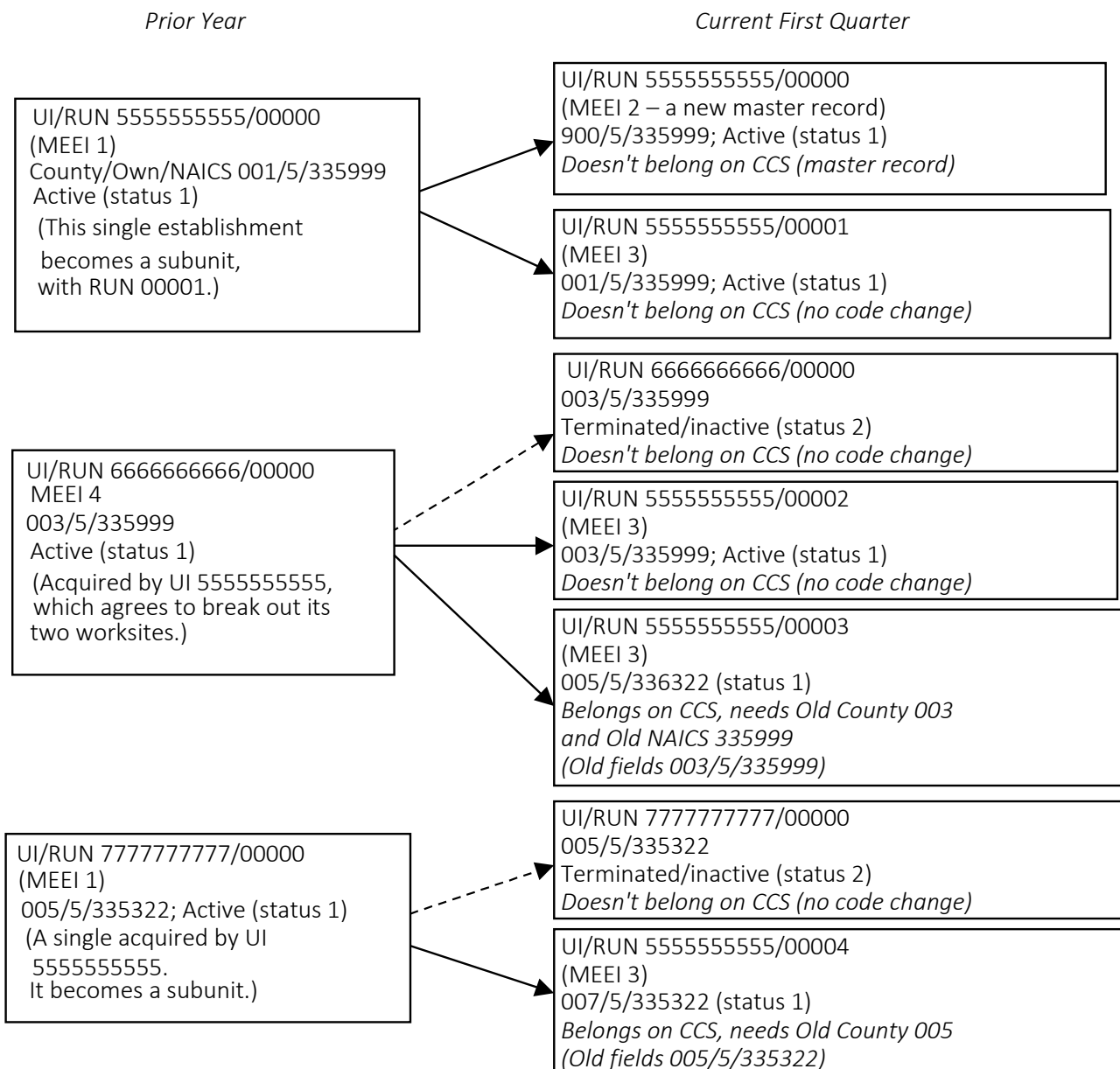

4. Transferring Employment to a Professional Employer Organization

Arrangements between Professional Employer Organizations (PEOs) and their clients represent a special case of successor reporting, usually at a different reporting level. Section 15.3 covers Professional Employer Organizations (PEO, NAICS=561330) reporting. This list summarizes key steps for establishments that transfer their employment to a PEO:

- Set up the reporting unit as a new multi-establishment worksite in the PEO's UI account.
 - Assign the UI Account Number and RUN under which the unit was formerly reported as the Predecessor UI and RUN of the new worksite. If possible, assign the unit's new UI Account Number and RUN as the Successor UI and RUN on the old record.
 - Determine the correct industry and geographic codes for the unit, based on its own location and activity rather than the PEO's location and activity (for example, do not assign NAICS 561330; assign the NAICS code representing the primary activity of the reporting unit).
 - If the industry and location codes formerly assigned to the unit are not correct, handle the correction as a noneconomic code change. Hold the code change until the next first quarter, and assign the necessary data elements (ARS Response Code, ARS Refile Year, and Old fields) that place the record on the CCS.
 - If the PEO-client relationship is terminated and the unit leaves (or moves to a different PEO), assign Predecessor and Successor UI/RUNs to maintain the linkage over time. Treat any code change that result from the reporting change as a noneconomic code change.
 - Under normal circumstances, if a breakout occurs in a PEO in mid-year (i.e., other than first quarter) and the breakout causes a change from one classified industry or area to another classified industry and/or area due to non-economic events, the code change(s) should be held by the state until the next first quarter and reported on the Code Change Supplement. However, for larger PEOs, handling and reporting breakouts, births, deaths, out-of-business units, or other reporting changes can become difficult and very time consuming for state QCEW staff. Clients enter in and out of relationships with PEOs regularly. It is advised in these particular cases that the state contact their appropriate BLS regional office for guidance and/or assistance in handling these more difficult PEO cases.

5.5 Breaking Out (Disaggregating) New Multiple Worksite Reporters

Introducing Data from Initial Multiple Worksite Reports

1. Breakouts Held for the First Quarter Report

A breakout should be treated as a noneconomic code changes when a new Multiple Worksite Report (MWR) is received and the new worksites have different industry or geographic codes than the original single. In order to prevent midyear breaks in employment and wage data, breakouts with code changes should be introduced during first quarter processing. Data from an initial first quarter Multiple Worksite Report should be included in the EQUI File for that quarter.

States should consider adding new multi-establishment employer breakouts during any quarter of the year as long as the industry code, county, township, and ownership codes are maintained (held the same as before the breakouts) until the next first quarter. This is explained in more detail later in this section.

Changes in industry/ownership/area that result from information on the Multiple Worksite Report or from other sources are noneconomic code changes that need to be treated as noneconomic code changes so that the results are included on the Code Change Supplement files. Use the procedures described in Section 11.5.1 so that worksite records with these noneconomic code changes are placed on the CCS.

Each new sub-unit that has an industry or geographic code different than the previously combined unit belongs on the CCS; however, the combined, or master, record does not belong on the CCS. An example will further clarify this CCS reporting procedure. Assume the following is a record for a multi-establishment unit employer before being broken out:

UI Number	RUN	MEEI	County	Own	NAICS	Employment
1234567890	00000	1	001	5	335999	350

After being identified as a multi-establishment employer, the record is broken out into three subunit (worksite) records:

Establishment	UI Number	RUN	MEEI	Cnty	Own	NAICS	Emp	Belongs on CCS
A	1234567890	00001	3	001	5	335999	250	No
B	1234567890	00002	3	003	5	335999	50	Yes
C	1234567890	00003	3	003	5	336322	50	Yes

Since establishment A has the identical classification codes as the previously combined unit, this record should not be on the CCS. Establishment B has a county code (003) that is different from the previously combined unit, while establishment C has different county and industry codes (003 and 336322). Therefore, these two records should be included on the CCS with the following Old and New fields:

CCS Record

RUN	MEEI	Old County	Old Own	Old NAICS	New County	New Own	New NAICS
00002	3	001	5	335999	003		
00003	3	001	5	335999	003		336322

This is also illustrated in the following diagram:

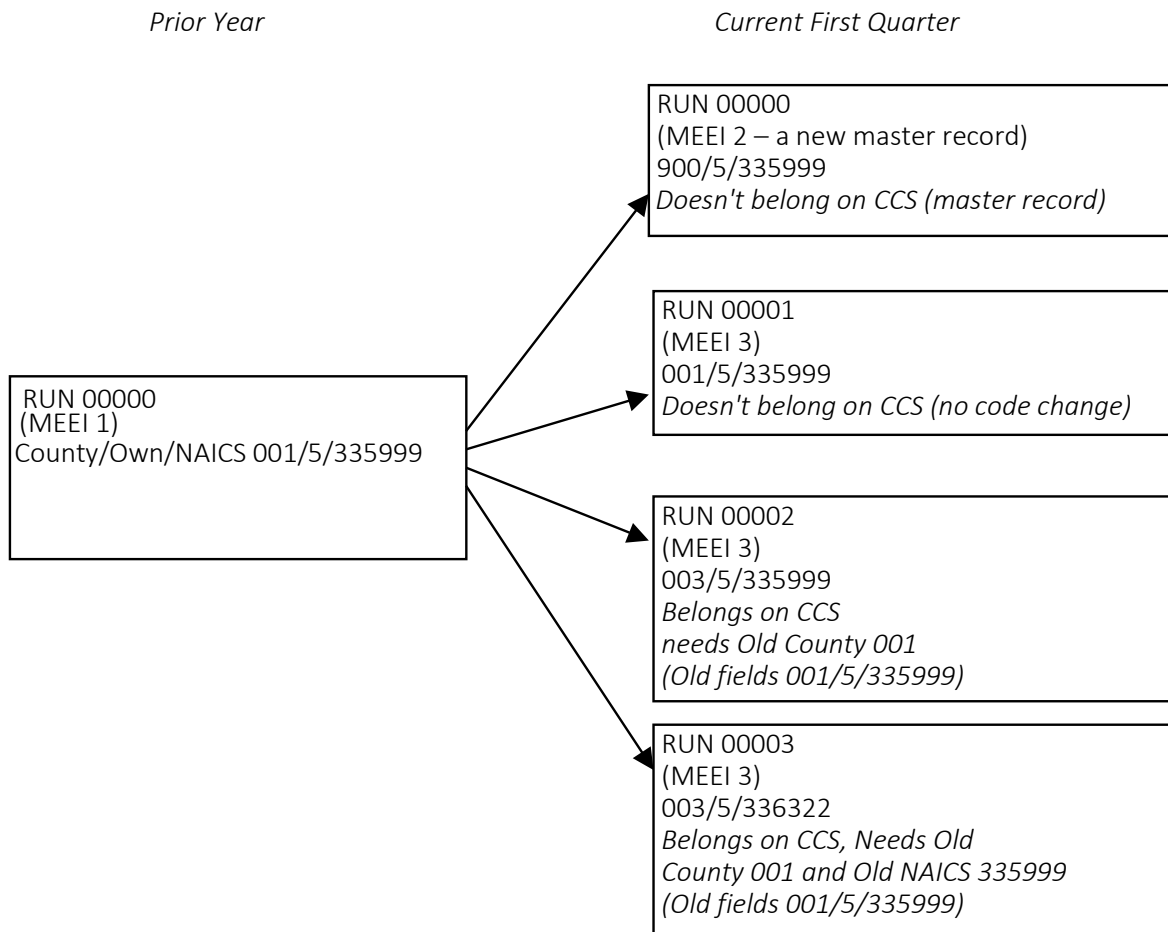

To be included on the CCS, RUNs 00002 and 00003 need the Old fields and first quarter codes on the state system consistent with the codes in the diagram. Section 11.5.1 describes how the Old fields, ARS Response Code, and other data elements are assigned that will put the record onto the CCS file.

The record with RUN 00000 remains as an active record; however, its Multi-Establishment Employer Indicator (MEEI) code should become 2. It does not belong on the CCS. Although it continues to show employment and wage data (equal to the sum of the data on the subunits), its MEEI code (2) will exclude it from the macro file and the CCS.

2. Breakouts Introduced in Pending Status before First Quarter

In the example above, the new subunit records do not exist before first quarter. The state could also create the subunit records before first quarter and keep these records in pending status (Status Code = 9). Code 9 prevents their economic data from being used on the macro file. The new pending records can use the correct classification codes – the county, ownership, and industry codes they will carry in first quarter. The RUN 00000 record continues to carry MEEI 1, 4, or 6 through fourth quarter, so its economic data continue to be used on the macro file. Beginning in first quarter, the subunits become active (Status Code = 1) while the RUN 00000 record becomes a master with MEEI 2. As in the first example, RUNs 00002 and 00003 belong on the CCS and should carry Old fields showing where the data were reported on the active record in fourth quarter.

Prior Year, First & Second Quarters *Prior Year, Third & Fourth Quarters* *Current First Quarter*

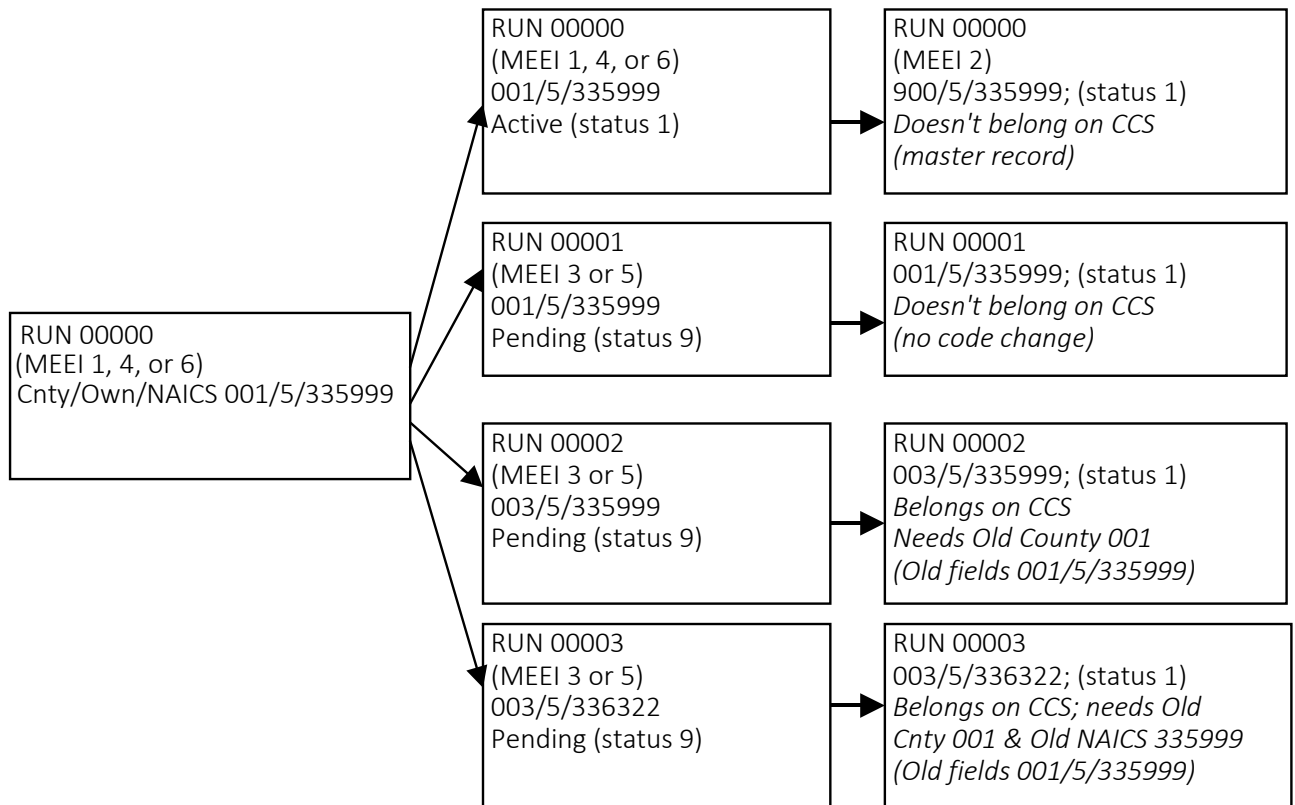

3. Data Included in the Current Quarter

Under certain circumstances, data from initial Multiple Worksite Reports for multi-establishment accounts should be used in preparing the EQUI File for the quarter for which they are received. These situations are as follows:

- a. An employer with an existing business opens a new worksite (a birth, not a successor). Report the new operation in the month when it began, using its current industry and area codes. Births do not belong on the CCS.
- b. A Multiple Worksite Report is received for a multi-establishment account whose industry and/or county was unclassified (i.e., NAICS 999999 or County 995-999, respectively) on the previous quarter's file. This is not a noneconomic code change, but a change from unclassified. It does not belong on the CCS. (An exception to this rule occurs if the change from unclassified is combined with a change from one specific county or industry code to another. In that case, it is treated as a noneconomic code change.)
- c. A Multiple Worksite Report is requested when a new UI account is established as a multi-establishment employer. If the new account is, in fact, a successor to an active account, the guidelines regarding successors determine when the data should be reported. (Refer to Section 5.3) For multi-establishment employers, the total account employment should be used when applying those guidelines. In other words, it is not necessary to handle a code change as noneconomic if total employment for the UI account is 25 or less in the last month before or the first month after the change from the predecessor UI account.
- d. New breakouts of multi-establishment employers with MEEI codes of 1, 4, or 6 can be broken out to MEEI codes of 3 or 5 during any quarter of the year. However, the state must follow these guidelines: the industry, county, townships, and ownership codes must be maintained (held the same as before the breakouts) until the next first quarter. While the reporting unit counts may potentially rise each quarter as a consequence, the employment and wages would not be adversely affected.

Consider the following example in which a multi-establishment employer begins reporting in a quarter other than the first quarter:

Old Record

UI Number	RUN	MEEI	County	NAICS	Employment
3456789012	00000	4	005	452111	400

New Records (Master and Subunits)

UI Number	RUN	MEEI	County	NAICS	Employment
3456789012	00000	2	005	452111	400
3456789012	00001	3	005	452111	150
3456789012	00002	3	005	452111	130
3456789012	00003	3	005	452111	120

There is no effect on the county or industry in the above case. No discontinuity in data for the macro cell would appear, except in the number of reporting units. As a result, it is acceptable to introduce the breakout when first reported.

Consider a second, slightly different example:

Old Record

UI#	RUN	MEEI	County	NAICS	Employment
3456789012	00000	4	001	335999	400

New Records (Master and Subunits)

UI#	RUN	MEEI	County	NAICS	Employment
3456789012	00000	2	900	335999	400
3456789012	00001	3	001	335999	250
3456789012	00002	3	003	335999	80
3456789012	00003	3	003	336322	70

Here the worksites with RUNs 00002 and 00003 are in a different county than the original record, and RUN 00003 is also in a different industry. There is a greater effect than in the first example. A shift of 150 employees would occur, plus their corresponding wages, from county 001 to county 003, while 70 of those employees shift from NAICS 335999 to 336322. Such a noneconomic change within the year should be prevented. This breakout can be introduced when first reported, however, provided the state meets one important requirement. The second and third worksites (RUNs 00002 and 00003) must initially be coded in county 001 and NAICS 335999, where they were coded when grouped as part of the MEEI 4 record. The county and industry changes must then be held until first quarter and included on the Code Change Supplement. The other worksite should not be included on the CCS because it has no code changes. Beginning with the first quarter, RUN 00002 should appear in the correct county (county 003) while RUN 00003 should appear in county 003 and NAICS 336322.

The reporting principle is as follows: breakouts may be introduced in mid-year, if necessary, but the industry and county code changes should be held through the end of the year and introduced in the next first quarter. The key in all these situations is that industry and area codes should not change in mid-year because of noneconomic reporting changes.

The example above is repeated in the following diagram, illustrating the use of the Old fields. Note that in this case, the Old fields match the fourth quarter codes of each reporting unit (but should not match the fourth quarter codes of RUN 00000).

Prior Year, First & Second Quarters Prior Year, Third & Fourth Quarters Current First Quarter

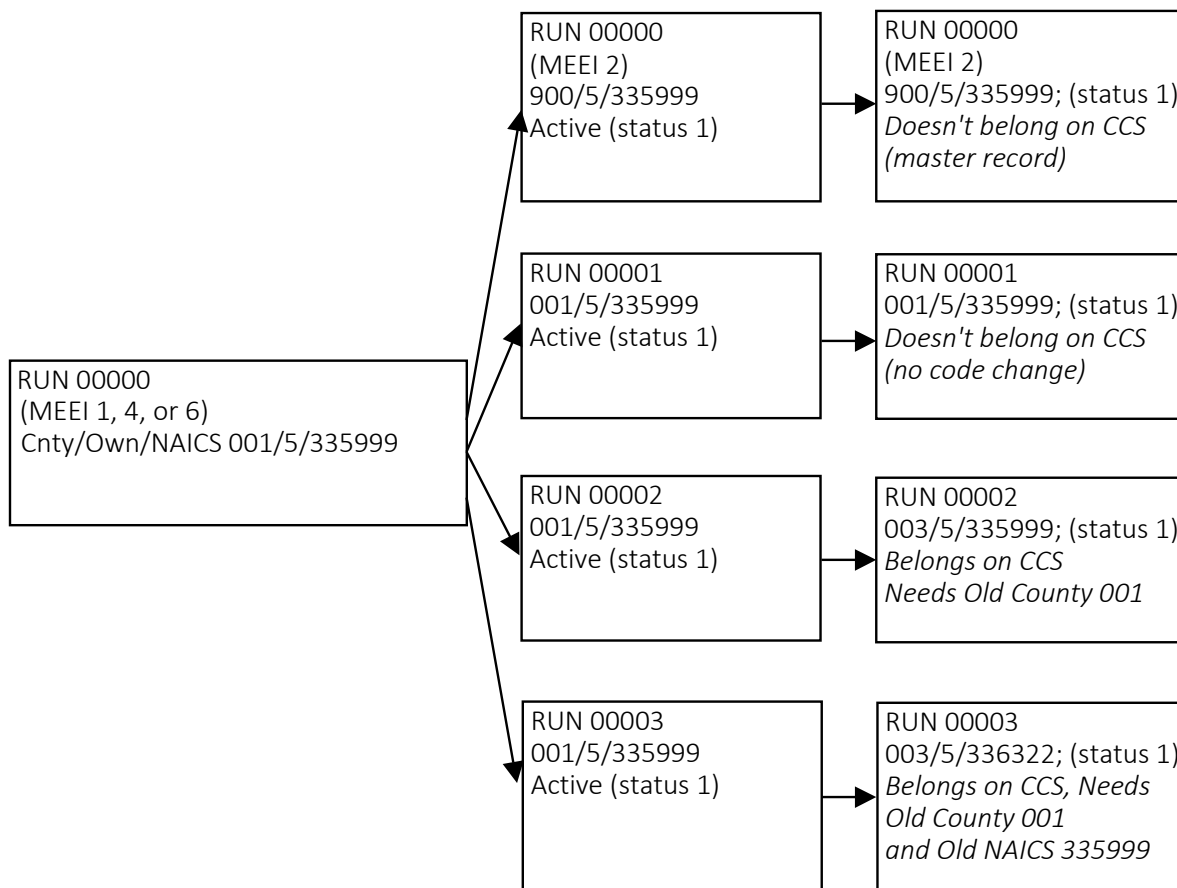

Introducing Data from Existing Multiple Worksite Reports

If a multi-establishment account consistently submits quarterly Multiple Worksite Reports as requested, the data from the form will always be used in preparing the EQUI File for the quarter for which they are received.

Establishments of multi-establishment employers should be treated in the same manner as single establishments with regard to changes in product or activity, location, and, of course, births. Thus, data from a Multiple Worksite Report received when a multi-establishment account adds one or more establishments during any quarter would be used in preparing the EQUI File for the quarter for which they are received. Such new establishments are births and do not belong on the CCS.

Records with MEEI code 5 (comprised of more than one establishment or worksite) can be broken out to become several records with an MEEI code of 3 (worksite or establishment level). If this reporting change causes economic data to be reported with different industry or

county/town codes than before, the code change is noneconomic and belongs on the CCS. The following diagram gives an example.

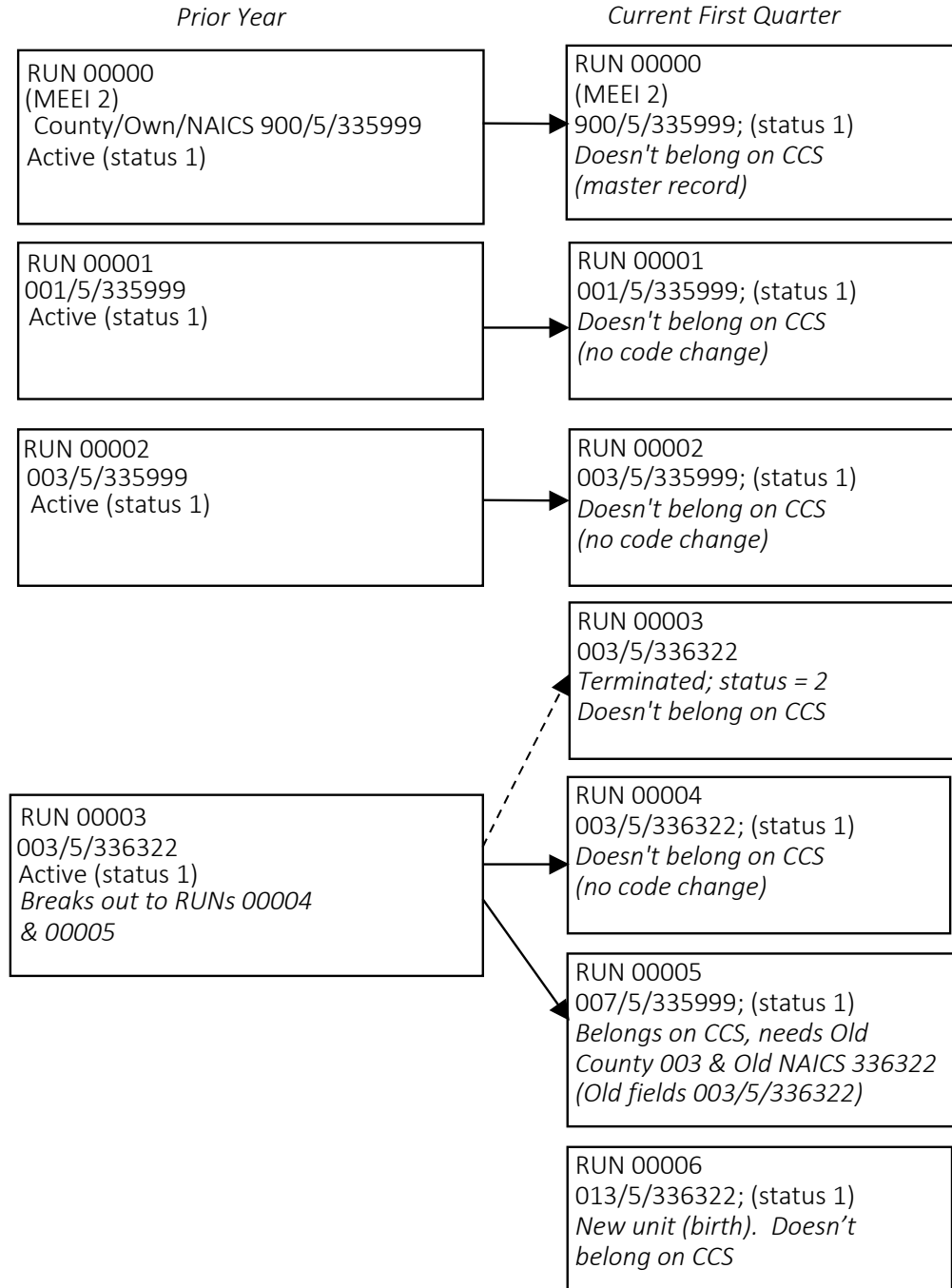

Note that in this previous case, there are several possible ways the configuration of active RUNs in fourth quarter could map to the configuration in first quarter. For example, all three new RUNs (00004 through 00006) could be interpreted as births, or all three could be considered successors to RUN 00003. The proper assignment of Old fields (along with other data elements such as ARS Response Code) will allow BLS and state systems to generate CCS records that reflect the actual movement of employment and wages between macro cells. In addition, the proper assignment of Predecessor UI/RUN fields will provide the linkage to map the new RUNs to the fourth quarter RUNs.

Records with MEEI 5 can be broken out to become several records with an MEEI code of 3 during any quarter of the year within the following guidelines: the industry, area, and ownership codes must be maintained (held the same as before the breakouts) until the next first quarter. While the reporting unit counts may potentially rise each quarter as a consequence, the employment and wages within a macro level cell would not be adversely affected. The following shows an example:

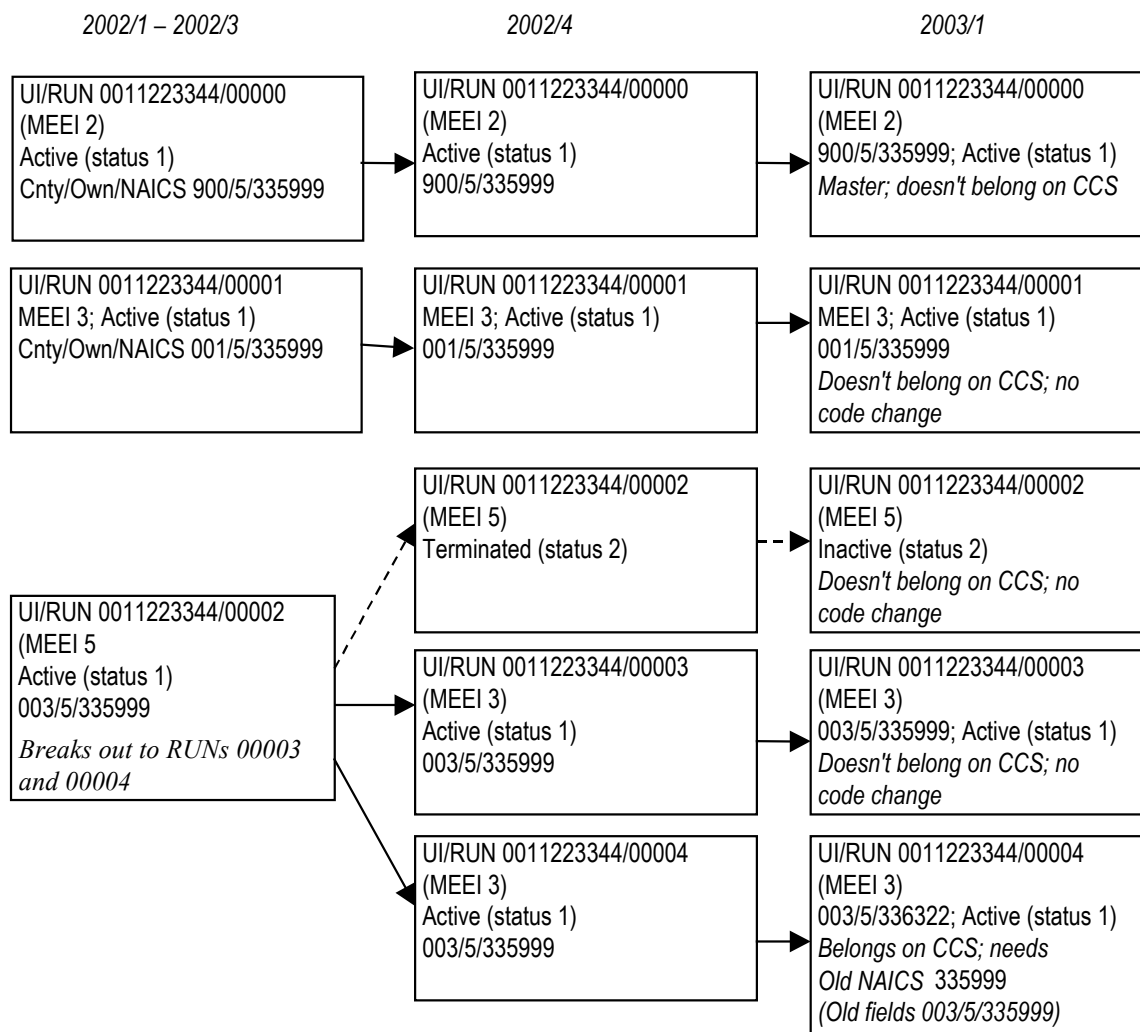

5.6 Consolidating Multiple Worksite Reporters

One Remaining Worksite and other Multi-establishment Situations

Most states do not store individual multi-establishment worksites on the UI tax file. For those that do, the Reporting Unit Number assignment on the tax file may not be the same as required for the QCEW program. In these cases, where a multi-establishment employer sells or closes all but one worksite, RUNs for the remaining worksites should be terminated (made inactive). The data from the QCR should be reported as RUN 00000. Any single worksite where it is the one and only remaining worksite with a RUN greater than zero will fail the micro edits.

There may be instances in which a multi-establishment employer who has been regularly submitting quarterly Multiple Worksite Reports either refuses or becomes unable to provide an establishment-level breakout on a quarterly basis. When this occurs, there are three main concerns:

1. Can the state obtain other information (explained below) to prorate employment and wage data from the QCR on an ongoing basis?
2. If the answer to the first question is no, and the employer discontinues reporting in the middle of the year, how can the state avoid showing a discontinuity in data resulting from collapsed reporting?
3. How should the collapse be represented on the Code Change Supplement?

After learning of the change in reporting, the state should initially try to negotiate with the employer to obtain complete establishment breakout information for at least one quarter of the following year. If the employer agrees to report for one quarter a year, the state should use the data obtained from the reported quarter to estimate data for the remaining quarters. States may also examine other available sources of information to estimate establishment breakouts, including CES data and the employer's wage records. (See Section 3.5 for more detail.)

If the state is not able to obtain data for one quarter a year to prorate employment and wage data, and the employer has discontinued reporting in the middle of the year, it is important for the state to continue estimation of establishment-level data for the remainder of that calendar year. The state should first attempt to use data captured for one of the earlier quarters to prorate data from the QCR to the worksite level for the remaining quarter(s). Again, states may also be able to use CES data and the employer's wage records to estimate data for the remainder of the year. The state should choose whatever method it deems most reliable.

The state should estimate the employer's establishment-level data through the fourth quarter of the year, prorating from available data. If the employer is still unwilling or unable to provide establishment-level data at the end of the year, the state may then collapse all subunit (worksite) records into the primary worksite for the following first quarter. To do this, inactivate the subunit records in the first quarter and stop reporting employment, wage, and other economic data on these records (the records with RUN greater than 00000). Change the MEEI code of the

record with RUN 00000 from 2 (master) to 4 (multi reporting as a single). Set the first quarter codes of this record equal to the industry and geographic codes of the primary worksite (subunit). If there is no primary county (i.e., no single county representing 50% or more of the employment of the UI account), use county code 995. (See Section 3.5.)

The state should collapse establishments only at the end of the year, and only after all attempts to persuade the employer to report have failed. If collapsing a large multi will move substantial employment between industries or counties, the state should consider prorating for an additional year while continuing to negotiate for disaggregated data.

Including Collapsed Worksites on the Code Change Supplement

To assist in explaining shifts in macro data, a Code Change Supplement record should be generated for each subunit record that was in a county or industry different from the primary establishment. Section 11.5.2 gives the procedures for this. Only subunits that had a county or industry code different from the new consolidated record belong on the Code Change Supplement. An example will further clarify this reporting procedure. Assume the following records were part of a multi-establishment employer before the establishments had to be collapsed:

Worksite	UI Number	RUN	MEEI	NAICS	County	Ownership	Employment
Master	1032547698	00000	2	511110	900	5	400
A	1032547698	00001	3	511110	001	5	250
B	1032547698	00002	3	511110	003	5	50
C	1032547698	00003	3	451110	001	5	50
D	1032547698	00004	3	451120	015	5	50

After the collapse, the employer should be reported in the first quarter as follows:

UI Number	RUN	MEEI	NAICS	County	Ownership	Employment
1032547698	00000	4	511110	001	5	400

Establishments B, C, and D are the only units from this account that should be included on the CCS because they are the only units with changes to the industry code and/or county codes. Establishment B (RUN 00002) had a county code different than the new aggregated record; establishment C (RUN 00003) had an industry code different than the new aggregated record; establishment D (RUN 00004) had both an industry code and a county code different than the new aggregated record. Therefore, these three records should be included on the CCS report as follows:

CCS Record

RUN	Old County	Old Own	Old NAICS	New County	New Own	New NAICS	Dec. Emp	MEEI
00002	003	5	511110	001			50	3
00003	001	5	451110			511110	50	3
00004	015	5	451120	001		511110	50	3

The Old fields on the state system become the Old fields on the CCS. The first quarter codes on the state system become the new fields on the CCS, even though the first quarter is inactive:

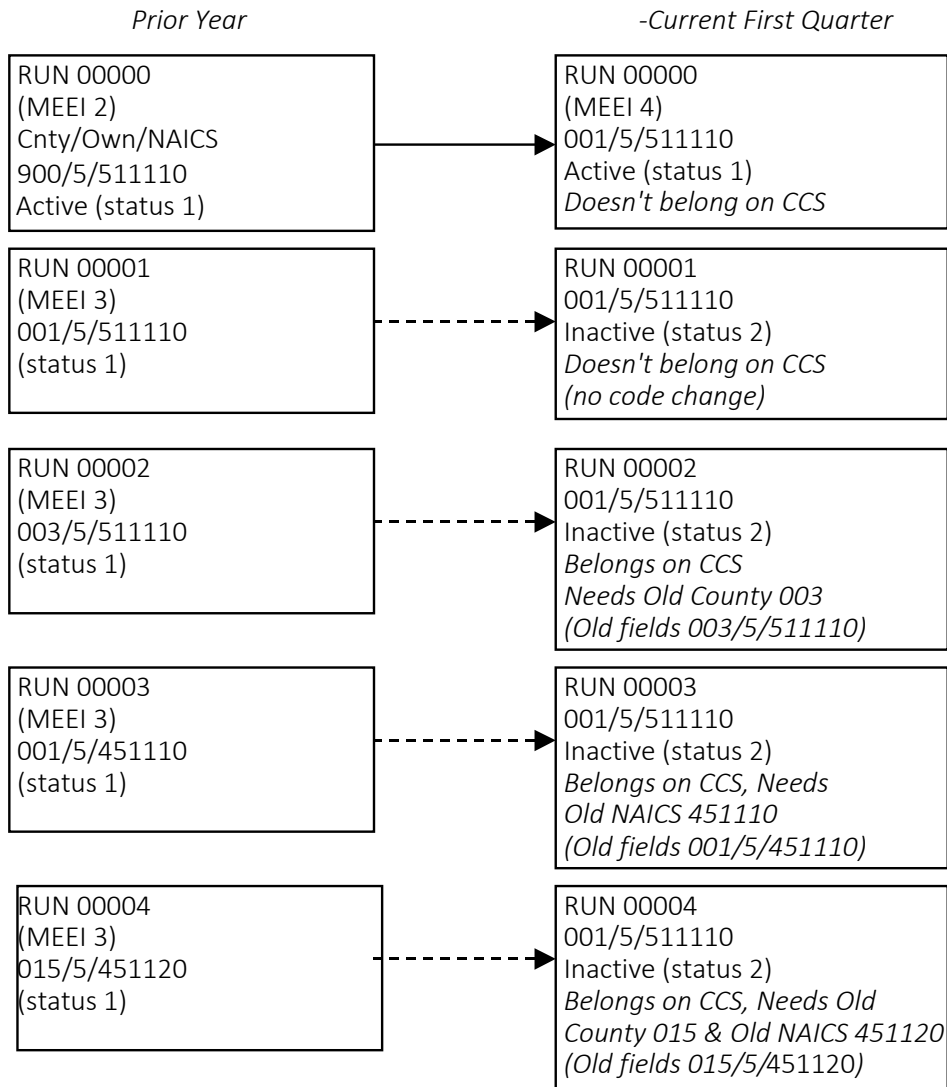

Chapter 11, and in particular Section 11.5.2, explains how to assign Old fields as well as the ARS Response Code and other data elements needed to include the subunit records with code changes on the CCS.

5.7 Tracking Establishments that Change UI or Reporting Unit Numbers in the LDB

This section describes the record linkage process used by the Longitudinal Database (LDB) System. The record linkage system constructs longitudinal data by linking records over time. The data proceed through a series of steps comparing establishments in the current quarter with establishments in the prior quarter. The order of the steps involved in the record linkage process is listed below.

1. Identification of SESA ID Links
2. Removal of successors in fully-imputed, single unit SESA ID links
3. Identification of inter-quarter predecessor/successor code links
4. Identification of inter-quarter breakouts/consolidations
5. Identification of inter-quarter weighted matches
6. Identification of intra-quarter predecessor/successor links
7. Identification of intra-quarter breakouts/consolidations
8. Fully-imputed single unit links

For more detail about the data of the QCEW Program, see Chapter 1.

5.7.1 LDB Linkage Process

Step 1 - Identification of SESA ID Links

The files are first linked by the state FIPS code/UI/RUN combination, the “SESA ID.” Approximately 95 to 97 percent of the current quarter’s records match by SESA ID, with the percentage of SESA ID matches from first quarter to fourth quarter being at the lower end of that range. Matches by SESA ID do not undergo any type of validation; it is assumed that they are accurate. A SESA ID link takes precedence over any other type of link involving a particular unit.

Step 2 - Removal of successors in fully imputed, single unit SESA ID links

Fully imputed subunits of multi-establishment employers (records with MEEI Codes of 3 or 5) that match by SESA ID are assumed to be valid matches and are removed from the matching process along with the SESA ID matches involving non-imputed records. SESA ID links

involving current quarter, fully imputed, **single** units (those with MEEI codes of 1, 4, or 6) are not initially accepted.

Step 3 - Identification of inter-quarter predecessor/successor code links

The system next links records across quarters that match via state-assigned Predecessor or Successor codes. To be considered, records cannot have been linked via SESA ID earlier in the process (unless they are fully imputed single units). One-to-one predecessor/successor code matches do not undergo any type of validation. The state-provided information is assumed correct.

Step 4 - Identification of inter-quarter breakouts/consolidations

The system next attempts to identify cases of administrative reporting changes occurring between quarters. The system looks for these changes both within and between UI accounts. The system identifies as breakouts or consolidations those records within a quarter that have repeated predecessor or successor UI/RUN combinations and the single units in the other quarter that they point to. In addition, the system checks UI accounts that have changed between quarters from a single unit reporter to a multi-establishment reporter and vice versa and that may or may not have predecessor/successor information on them. In the situation when predecessor/successor numbers are not present, if an UI account's employment changes between the third month of the prior quarter to the first month of the current quarter by 50 percent or less (based on prior quarter employment), that UI account is also identified as a breakout or consolidation.

This employment change edit is run on all potential inter-quarter breakouts and consolidations – those with predecessor and/or successor information and those without it. When the employment check is run on those situations identified by predecessor/successor information, the system will not overturn the identification based on employment change, but adds a flag describing whether the employment changed more or less than 50 percent. When the employment check is run on potential breakouts and consolidations not identified by predecessor/successor information (always within a UI account), a breakout or consolidation is identified only if the employment difference between the two periods is within the range of 50 percent.

Step 5 - Identification of inter-quarter weighted matches

In 2015 QCEW implemented the Weighted Match replacement to the earlier probability-based weighted match process. This replacement was motivated by several factors: a need to improve weighted match record linkages; limited technical support from the vendor; and significant annual cost savings for the QCEW program. The replacement Weighted Match system measures the similarity of two records by calculating a weighted Euclidean distance between them. This is a departure from the previous method of probabilistic record linkage.

Based on a relatively small number of QCEW variables, given in the table below, this distance is scaled to the [0-1] range and is constructed such that higher numbers, or scores, represent greater similarity between records. Thus, a score of one would constitute a perfect record match, while a score of zero would suggest that there is no measurable similarity between the two records at all; i.e. they are perfectly dissimilar in the context of the 2015 matching system. Unique variables, including EIN, names, Reporting Unit Description, and address are given higher weights. Conceptually, it is desirable that record pairs with high scores are flagged as links, while those with low scores are discarded. Informed by empirical review, the value applied as a cutoff was about 0.58, which was selected as a satisfactory compromise between missing too many good links (by setting the cutoff too high) and flagging too many bad links (by setting the cutoff too low). Additionally, a second criterion was implemented: if the record pair sufficiently matches on a combination of critical variables, despite having a low score (typically due to missing data), a link between the records is established.

New Weighted Match Components

Linkage Variable	Type
EIN	Categorical
County	Categorical
Phone Number	Categorical
NAICS	Categorical
Average Quarterly Employment	Numeric
Total Quarterly Employment	Numeric
Total Quarterly Wages	Text
Standardized Trade Name	Text
Standardized Legal Name	Text
Reporting Unit Description	Text
Physical Location Address	Text
City and Zip Code	Text

The new QCEW Weighted Match program was implemented with the fourth quarter 2014 linkage process, conducted in May 2015. These data were published July 29, 2015.

Step 6 - Identification of intra-quarter predecessor/successor links

Within the current quarter, records that link to each other via predecessor and/or successor numbers are considered a valid match. All current quarter records are considered as potential predecessors in the intra-quarter matching. The successor records involved in these matches, however, are not allowed to match to the prior quarter. Records with a match to the prior quarter that were identified before entering this component are not given the opportunity to be successors in this step. Likewise, once a record is identified as a successor in an intra-quarter match, it cannot match to the prior quarter in subsequent phases of the process.

The successor records identified in the weighted match, step five, subsequently are allowed to match as either predecessors or successors in the intra-quarter matching. If one of these records

links as a successor in the intra-quarter matching, the weighted link to the prior quarter will be broken and the intra-quarter link will be accepted.

The system can have only one record on the database representing each individual continuous unit identified by a unique LDB number. To meet this requirement, the system merges the pair of records linked within the current quarter. The merged record retains the administrative information of the successor. The system determines which record's employment to retain by comparing the monthly employment values independently for each month. If the successor's employment is greater than zero, then its employment and associated flag are retained. If the predecessor's employment is zero and the predecessor's employment is greater than zero, then the predecessor's employment and associated flag are retained. If both records have positive wages, the wages are combined in the merged record.

Step 7 - Identification of intra-quarter breakouts/consolidations

When the system identifies new current quarter records with repeated predecessor or successor UN/RUN combinations that point to a current quarter single unit, the involved units are identified as intra-quarter breakouts or consolidations. Similar to the one-to-one intra-quarter processing described above, the predecessor records involved in these situations are given the opportunity to match in all other phases of the matching process while the successor records are not allowed to match to the prior quarter – with one exception. The initial system will not allow predecessors in an intra-quarter breakout and consolidations to have been involved in an inter-quarter breakout or consolidation. Thus, combinations of inter- and intra-quarter breakouts and consolidations are not identified.

Similar to the way the system merges employment and wage data associated with one-to-one intra-quarter matches; the system also merges records involved in many-to-one and one-to-many intra-quarter matches. Similar logic is utilized to perform the merging but it is expanded to handle these more complex cases. The administrative information of the successor records is retained.

Step 8 - Fully imputed single unit links

A fully imputed establishment is one that has all three months of employment and quarterly wages imputed. When there are fully imputed current quarter units with MEEI Codes of 1, 4, or 6 that have a SESA ID match to the prior quarter, the prior quarter records involved are returned to the matching process after their identification (Step 2 of the Record Linkage process). These prior quarter records are then eligible to match in all other components of the matching process. Rather than assume that these units are delinquent, an attempt is made to identify the units that actually may have been reported under new ownership. Following completion of the matching process, if the prior quarter records were not linked to another current quarter record, they will be rejoined with their fully imputed current quarter counterpart.

5.7.2 Updates and the Linking Process

Only the "current" quarter's records and the "previous" quarter's records are involved in the linking process. Updates made to quarters that come before the "previous" quarter will not affect how records are linked. To illustrate, suppose that the current quarter is 2019/2 and that a file with a new SESA ID is submitted with no state assigned predecessor/successor numbers. The linking process is then performed on the file and no match is found. This file is considered a birth file. In the following quarter, 2019/3, a record for this file (same SESA ID) is submitted with a set of predecessor/successor numbers. The newly submitted, updated record is still a part of the linking process. The newly acquired predecessor/successor numbers allow the linking process to correct the "birth" status initially conferred upon the file. Accurate linkage is maintained on the LDB.

Now suppose a similar but different scenario. The current quarter is 2019/2 and a file with a new SESA ID is submitted with no state assigned predecessor/successor numbers. The linking process is performed on the file and no match is found. The file is then considered a birth file. In the following quarter, 2019/3, a record for this file (same SESA ID) is again submitted without a set of predecessor/successor numbers. This third quarter file is linked to the initial file submitted in second quarter. In 2019/4, a record for this file (same SESA ID) is submitted with predecessor/successor numbers. This fourth quarter file is correctly linked to the third quarter file with the same SESA ID. However, the file associated with this specific SESA ID is not linked to the predecessor/successor files as indicated by the predecessor/successor numbers submitted in the 2019/4 file.

Chapter 6 – Annual Refiling Survey

The main purpose of the Annual Refiling Survey (ARS) is to verify or correct the North American Industry Classification System (NAICS) and the geographic codes such as county and township (town, city, parish, or island in some states) assigned to establishments. Other important purposes of the ARS are to verify or update establishments' mailing and physical location addresses. The ARS also asks employers to identify new locations in the state.

This chapter outlines the ARS processing cycle, including criteria used to select establishments each year, response rate requirements, summary management reports, the categories of ARS data collected via the web, the Central Review, the BLS-3023 NVS (Industry Verification – Single), NVM (Industry Verification – Multi), and NCA (Non-Classified Account). NCAs are not included on the ARS Control Files, but similar collection and processing methods are used, so they are included in this section of the manual. This section also includes key portions of the web screens, survey responses and the different methods of processing including a chart of response codes associated with processing ARS Web responses. Also included is a section on Professional Employer Organizations.

-----Contents of Chapter 6-----

- 6.1 Purpose of the ARS
- 6.2 ARS Processing Cycles and Selection Criteria
- 6.3 ARS Response Rate Requirements
- 6.4 ARS Web and NVM Web Collection Screens and Solicitation
 - 6.4.1 Explanation of Key Areas of Online Collection Screens
 - 6.4.2 ARS Web and NVM Web Solicitation
- 6.5 ARS and NCA Processing
 - 6.5.1 ARS Response Codes
- 6.6 Collection Methods
 - 6.6.1 ARS Web and NVM Web
 - 6.6.2 BLS Central Review
- 6.7 Processing Professional Employer Organizations
- 6.8 Reports for BLS
- 6.9 Usable Response Rate and Total Response Rate
- 6.10 State ARS Responsibilities

6.1 Purpose of the ARS

The main purpose of the ARS is to verify or correct, if necessary, the NAICS code assigned to a business or business's subunit (in cases where a firm breaks out their UI account reporting into multiple establishments in a state). The NAICS code reflects the **main** economic activity of the business at that location, but may not reflect all activities conducted since only one code is assigned per reporting unit. The current industry description is presented to respondents reporting via the ARS Web System. If an employer disagrees with the presented (current) NAICS code description or is not sure that the provided NAICS description best reflects their operations, the ARS Web system requests that the employer provide additional details about the business activities at the location in question. State coders will review the information provided by the respondent and, if necessary, change the NAICS code assigned to the reporting unit.

Another important purpose of the ARS is to verify a business's mailing and physical location addresses. These addresses are stored in the Longitudinal Database (LDB). Several DOL statistical programs use the LDB as their sample frame so it is crucial that these fields are as up-to-date and accurate as possible. The physical location address (PLA) is where the employer conducts business. Therefore, the physical location address cannot be a Post Office Box or rural route number. Additionally, the physical location address must be accurate so that QCEW microdata can be properly geocoded at sub-county levels. Data in the QCEW Program are published by geographic location, so it is important to update location fields such as county, town, city or parish, to reflect the most current location.

Finally, the ARS asks employers to report on newer physical locations (e.g. stores or offices) operating in the state and the employment levels at these locations. State QCEW staff will use this location and employment information to determine whether or not the employer meets the criteria for solicitation as a multiple worksite reporter.

When there are changes to the NAICS, geographic codes, or ownership code, the state includes this information in the Code Change Supplement (CCS), a component of the Enhanced Quarterly Unemployment Insurance (EQUI) file. States also send mailing and physical location address changes to the national office in the EQUI every quarter. For more information on the timing and reporting of code changes refer to Section 2.3.2 of this manual.

6.2 ARS Processing Cycles and Selection Criteria

Every year, the states contact a subset of employers (roughly a third of eligible establishments) to obtain information that (a) confirms or corrects their accounts' NAICS codes to reflect the main business activity conducted at each location, and (b) confirms/updates each unit's geographic codes and addresses. This is called the Annual Refiling Survey (ARS).

Establishments in the survey are selected across industries using the seventh and eighth digits of the Federal Employer Identification Number (EIN). In year one, units in the range 00-33 are

surveyed. In year two, units in the range 34-66 are surveyed. In year three, units in the range 67-99 are surveyed. The following table illustrates a three-year ARS cycle.

EIN Digits	EIN Range	Year	Fiscal Year
7-8	00-33	1	2020, 2023, etc.
7-8	34-66	2	2021, 2024, etc.
7-8	67-99	3	2022, 2025, etc.

This processing cycle repeats itself in succeeding years. All establishments missing EINs (blank or zero-filled) are selected for the ARS based on the UI Account Number field. Two digits of the 10-digit UI Account Number field should be used in the same manner as the seventh and eight digits of the EIN. Most states use positions 9 and 8, respectively, of their UI Account Number. There are exceptions, as listed in the table below.

State	AL	ME	MS	MT	NE	NV	NY	NC	VT	VI	WA	WY
UIN Digits	6-7	5-6	5-6	9-10	6-7	6-7	9-10	9-10	10-9	10-9	6-7	5-6

ARS Selection Criteria Exclusions

The following establishments are excluded from the ARS.

1. Single-establishment UI accounts (MEEI = 1, 4, or 6) that were active during the selection quarter (1st Quarter of the prior FY) but had an average employment of less than or equal to three in the most recent 12 months, regardless of total wages, are excluded from the ARS. Accounts that were active during the selection quarter but not yet for 12 months, are still eligible for ARS selection; the calculation for average employment in these cases will use the number of active months in the denominator rather than the default of 12.
2. A subset of UI accounts on the Control File will have NAICS codes that show low rate change/correction into other main business activities (NAICS codes). With the lessened likelihood of reporting changes that the ARS would capture, this subset of UI accounts are solicited for ARS responses once every six years. This reduces respondent burden and processing costs with minimal impact on the currency of QCEW NAICS codes.

The table below lists the EIN ranges for single-establishment UI accounts (MEEI = 1, 4, or 6) on the *List of Low Change NAICS Codes* that are included and excluded from the ARS over the next six ARS years.

EIN Digits	EIN Range Include	EIN Range Exclude	Fiscal Year
7-8	17-33	00-16	2018
7-8	51-66	34-50	2019
7-8	67-83	84-99	2020
7-8	00-16	17-33	2021

7-8	34-50	51-66	2022
7-8	84-99	67-83	2023

3. A number of private employers, identified by their EIN, are included in the ARS but excluded from the ARS Print Files and email contact files. Instead of soliciting responses via the web from these large private establishments with well-known business activities, BLS reviews the NAICS codes of these companies in house. The states' role on the handling of these files and additional discussion on this topic is presented in Section 6.8.2.
4. Federal, state, and local government establishments are excluded from regular refiling. These establishments in ownership codes 1, 2, or 3 will not be solicited for ARS responses.
5. Unclassified establishments; those coded NAICS 999999, are excluded from the ARS. State QCEW staff work throughout the year to keep the number of unclassified accounts on their files at or below the cooperative agreement maximum-allowed level. State staff will email, call, conduct internet research, and mail information requests to employers to obtain enough information about an unclassified unit's operations to enable them to assign a NAICS code. States can opt to have BLS send NCA Web Letters to their unclassified single accounts each quarter.
6. Single establishments (MEEI = 1, 4, or 6) coded in NAICS 814110 (Private Households) are excluded from the ARS. Establishments that are assigned this NAICS code are households employing workers on or about the premises in activities primarily concerned with the operations of the household. These private households may employ individuals such as cooks, maids, nannies, butlers, and outside workers such as gardeners, caretakers, and other maintenance workers. These establishments do not provide services to the public outside of the household.
7. Multi-establishment UI accounts where the master RUN is coded in NAICS 561330 (Professional Employer Organizations) are excluded from the ARS.
8. Establishments in NAICS 491110 (Postal Service) are excluded from the ARS. Many of these will be in government and would be excluded on that basis. There are some in ownership 5 (private ownership) that are excluded based on their NAICS code.

The ARS Control File (CF)

At the beginning of each year, BLS creates a file for states called the ARS Control File, which contains all of the records that are part of the current year's ARS. The Data Collection Branch provides this file to the states. The Control Files are created using data from the 1st quarter EQUI deliverable received by BLS. This Control File creation marks the start of the ARS Year.

The Centralized ARS (CARS) [Checklists](#) are issued each year on StateWeb to provide states with a step by step guide to ARS processing, including loading the latest Control File, CARS Response files and ARS Web data.

6.3 ARS Response Rate Requirements

The Cooperative Agreement between each state and the Bureau of Labor Statistics details the required state-obtained, usable ARS response rate for units or employment. In addition to emails and the initial web letter mailing, BLS sends at least one follow-up web letter during the ARS Year as necessary for states to accomplish this goal. Some states will be afforded the mailing of a second follow-up web letter if response rates are trailing (to single worksite units only). States may also contact or research the business units to verify NAICS code and address in the absence of reported information.

6.4 ARS Web and NVM Web Collection Screens and Solicitation

States collect main-business-activity information for ARS purposes using online systems called *ARS Web* for single unit accounts, and *NVM Web* for multiple reporting unit accounts. BLS uses three online versions of forms to capture responses to the ARS. Originally these forms were printed on paper and mailed to eligible firms. With collection of the ARS having completely migrated to web-based collection, so have these forms; with the questions now asked on the ARS Web and NVM Web collection systems. Non-Classified Accounts (NCAs) are not part of the ARS but responses from these accounts are collected through ARS Web, so they are covered in the ARS section of the manual. The three forms on the web are:

1. BLS 3023-NVS – NAICS Verification, Single Locations

Requests information from single-unit establishments (MEEI 1, 4, 6) within a state. Respondents are asked to verify the industry description presented regarding the establishment's business activities and whether multiple locations exist within the state. The respondent is also asked to verify or correct physical location, mailing address, and county location, or to provide this information if any of these data elements are missing. This form is presented online and not mailed en masse as in prior years.

2. BLS 3023-NVM – NAICS Verification, Multiple Locations

Requests information from employers that have multiple worksites within a state under the same UI number reporting as sub-units (MEEI 3 and 5). Employers are asked to review industry descriptions for all of their worksites/establishments associated with that UI. If the description(s) is correct, the employer checks the "Correct" box for the establishment. If the description is incorrect for one or more of the establishments, the employer checks the "Incorrect" box and is then asked to provide an appropriate description of the establishment(s)' actual main business activity. Respondents have the option to choose "complete paper form" and are given the link to the blank form on the

public website. A respondent may fax or mail their completed form (from the public website) to the state office. Like the NVS collection, no NVM paper collection forms are mailed.

3. BLS 3023-NCA-Non-Classified Account, Information Request

Requests information from single-unit establishments (MEEI 1, 4, 6) within a state that are currently “unclassified”, or have a NAICS code of 999999, unclassified.

Respondents are asked to provide that establishment’s business activities and whether multiple locations exist within the state. The respondent is also asked to verify or correct physical location, and mailing address information or to provide this information if any of these data elements are missing.

For NCA collection, states can choose to have BLS email/mail solicitation letters, (without paper forms), requesting they provide this information online.

Alternatively, states can choose to print and mail paper NCA forms. If states take this approach, the respondents will not be able to respond via ARS Web. Instead, respondents will return the completed form to the state’s LMI shop.

6.4.2 ARS Web and NVM Web Solicitation

Firms that are selected for the ARS are solicited via email or mailed web letters.

Solicitation of NVS-Single Accounts

Email Blast Solicitation

Email blasting is the process of BLS sending emails to all single accounts (MEEI 1, 4, or 6) requesting their cooperation by logging into the Bureau’s ARS Web data collection system. There are two main sources of respondent email addresses that are used for these email blasts:

1. ARS Web records: BLS has email addresses on file in its systems from prior ARS Web collection. ARS Web collection began in FY 2012, so beginning with the 2015 ARS, email addresses from prior ARS cycles became available to BLS.
2. UI Tax emails: Many states’ UI tax departments have made firms’ email addresses available to BLS for the purpose of soliciting responses to the ARS via email. The Regional Office staff work with their state partners to collect these addresses and make them available to the national office. When states have access to the email addresses collected by their UI Tax departments and are able to share them with BLS, they are asked to provide an extract in the following format as a text file:

Position	Length	Data Element
----------	--------	--------------

1-2	2	State FIPS Code
3-12	10	Unemployment Insurance (UI Account Number)
13-267	255	UI Tax Business Email Address

Refer to Exhibit 6A for an ARS Email Template, which include the respondent's web id(s). See Exhibit 6B for an ARS Email Password Template, which is a second/separate email that conveys the password(s); a separate email is used to ensure confidentiality. Respondents can contact ARS Support Services through the ARS Respondents website or at ARS.Helpdesk@bls.gov and ask that their survey notice or password email be resent if needed.

ARS Web Letter Solicitation

BLS solicits responses to the refiling survey using web letters for both single accounts and multis. The web letter is a single page containing a Web ID and password along with the link for reporting online. ARS first mailings, and subsequent follow-up mailings, will take place after email blasts. BLS monitors response rates to the email blasts and the first and second web letter mailings. A third mailing is offered to a subset of states where lower response rates are observed.

Exhibit 6C depicts a sample NVS web letter for a mandatory state and Exhibit 6D shows the NVS web letter that would be used in a voluntary state.

Solicitation of NVM-Multi-Establishment Accounts

NVM accounts that are already MWR Web respondents are asked to complete the Industry Verification on-line after submitting their Multiple Worksite Report. Generally they are solicited via MWR Web during 2nd quarter collection and non-respondents are asked again to complete the NVM during 3rd quarter collection.

NVM eligible accounts that are not currently reporting multiple worksite reports through the MWR Web system are mailed web letters with login credentials. With this information they can report NVM data online without having to report MWR data. These respondents are typically mailed the web letters during 3rd quarter collection and a follow-up letter is typically sent during 4th quarter collection in case of nonresponse. Exhibit 6E and Exhibit 6F show NVM web letters for mandatory and voluntary states, respectively. The NVM letter is double-sided with the back providing instructions to the respondent for logging into the IDCF and reporting. Exhibit 6G shows the reverse of the NVM letter.

Both types of NVM respondents have the option to choose "complete paper form" and are given the link to the blank form on the public website. No paper NVM forms are sent by BLS.

Exhibit 6A ARS Email Template

Email to All Employers

From: AnnualRefilingSurvey@bls.gov

To: *[Respondent Email]*

Subject: Annual Refiling Survey Notice

Dear *[Respondent Name]*,

Every three years, *[State Agency Name]* and the U.S. Bureau of Labor Statistics (BLS) request that you verify your firm's address and main business activity through the Annual Refiling Survey (ARS). The ARS has been moved online and your email address was obtained from your State Unemployment Insurance (UI) filing, or because you filed this report online in the past. Please log on to our secure website and report online to reduce costs and save tax dollars.

Please log on to our secure website to complete your report: <https://idcfars.bls.gov/>

WEB ID 1: *[991234567890]*

WEB ID 2: *[991234567891]*

PASSWORD: Your 8-character password has been sent in a separate email. If you cannot find the password email in your inbox or SPAM folder, you can submit a request to have your password resent: <http://data.bls.gov/cgi-bin/forms/ars/?respondents/ars/home.htm>

Please complete the ARS within **14 days**. If you are having difficulty accessing the system, please see our illustrated step-by-step instructions on www.bls.gov/respondents/ars/arswebreporting.htm

The ARS *[is mandatory in accordance with [State law] and]* is authorized by 29 U.S. Code, Section 2. Your cooperation is needed to make the results of this survey complete, accurate, and timely. The Industry Verification Form, BLS-3023 is approved with O.M.B. No. 1220-0032, in cooperation with the U.S. Department of Labor. The information collected will be used for statistical and Unemployment Insurance program purposes and other purposes in accordance with law. Additional information regarding this survey can be found at:

www.bls.gov/respondents/ars

Thank you,
U.S. Department of Labor
Bureau of Labor Statistics

The Bureau of Labor Statistics (BLS) is committed to the responsible treatment of confidential information and takes rigorous security measures to protect confidential information in its possession. This email contains confidential information. If you believe you are not the intended recipient of this message, please notify the sender and delete this email without disclosing, copying, or further disseminating its contents.

Exhibit 6B ARS Email Password Template

Password Email

From: AnnualRefilingSurvey@bls.gov
To: [Respondent Email]
Subject: Annual Refiling Survey - PASSWORD

Dear [Respondent],

To complete the Annual Refiling Survey (ARS) online, please use the Web ID(s) from the email you recently received with the subject line: 'Annual Refiling Survey Notice,' along with your password(s) below to log on to our secure website: <https://idcfars.bls.gov/>

PASSWORD1: [Ab123456]

PASSWORD2: [Bc234567]

If you copy and paste the password, please ensure that you are only copying the 8-character password with no spaces before or after.

If you cannot locate the Annual Refiling Survey Notice email, please check your email's SPAM folder. If you cannot find the email in your inbox or SPAM folder, you can submit a request to have your survey notice resent: <http://data.bls.gov/cgi-bin/forms/ars?/respondents/ars/home.htm>

Additional information regarding this survey can be found at: www.bls.gov/respondents/ars

Thank you,
U.S. Department of Labor
Bureau of Labor Statistics

The Bureau of Labor Statistics (BLS) is committed to the responsible treatment of confidential information and takes rigorous security measures to protect confidential information in its possession. This email contains confidential information. If you believe you are not the intended recipient of this message, please notify the sender and delete this email without disclosing, copying, or further disseminating its contents.

Exhibit 6C ARS NVS Web Letter – Mandatory State

CALIFORNIA EMPLOYMENT DEVELOPMENT DEPARTMENT
LABOR MARKET INFORMATION DIVISION
P.O. BOX 826220
SACRAMENTO, CA 94299-0977
Phone: 1-800-562-3366



UNITED STATES DEPARTMENT OF LABOR
Bureau of Labor Statistics
Washington, D.C.

BLS 3023 - Industry Verification Form

MANDATORY

Z9999-NVS-0002618 P02 T00007 *****MIXED AADC 159
SAMPLE A SAMPLE COMPANY
SAMPLE INC 020
SUITE 119
142 ANY STREET
ANY CITY, US 94030

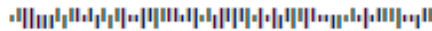

06

XXXXX XX, XXXX

Dear Employer,

Every three years, the California Employment Development Department and the U.S. Bureau of Labor Statistics (BLS) request that you complete the Annual Refiling Survey to verify or provide general business information about your firm. Your cooperation is essential so that we are able to produce data that are complete, accurate and timely.

To reduce costs and save tax dollars, this survey has been moved online and can be completed in 5 to 10 minutes. Please use the Web ID and password provided below to log into the secure BLS website: <https://idcfars.bls.gov>

WEB ID: 100000000002

PASSWORD: Zz000020

This survey is **mandatory** in accordance with Section 320.5 of the California Unemployment Insurance Code and Section 320-1 Title 22 of the California Code of Regulations and is authorized by 29 U.S. Code, Section 2.

The BLS-3023 form is approved with O.M.B. No. 1220-0032, in cooperation with the U.S. Department of Labor. The information collected by the California Employment Development Department and BLS will be used for statistical and Unemployment Insurance program purposes and other purposes in accordance with law. Additional information and instructions for this survey can be found at: www.bls.gov/respondents/ars

Please provide your response within **14 days**. If you have already submitted this report, please disregard this notice and accept our thanks for responding.

Sincerely,

Emily Thomas
U.S. Bureau of Labor Statistics



En Español: www.bls.gov/respondents/ars/espanol.pdf



0002618

Exhibit 6D ARS NVS Web Letter – Voluntary State

ALABAMA DEPARTMENT OF LABOR
LABOR MARKET INFORMATION DIVISION QCEW
640 MONROE ST
ROOM 4427
MONTGOMERY, AL 36131-2280
Phone: (334) 242-8873



UNITED STATES DEPARTMENT OF LABOR
Bureau of Labor Statistics
Washington, D.C.

BLS 3023 - Industry Verification Form



Z9999-NVS-0006191 P03 T00015 *****SCH 5-DIGIT 63166
SAMPLE A SAMPLE COMPANY
SAMPLE INC 001
SUITE 100
123 ANY STREET
ANY CITY, US 63166-0283

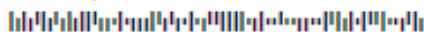

01

XXXXX XX, XXXX

Dear Employer,

Every three years, the Alabama Department of Labor and the U.S. Bureau of Labor Statistics (BLS) request that you complete the Annual Refiling Survey to verify or provide general business information about your firm. Your cooperation is essential so that we are able to produce data that are complete, accurate and timely.

To reduce costs and save tax dollars, this survey has been moved online and can be completed in 5 to 10 minutes. Please use the Web ID and password provided below to log into the secure BLS website: <https://idcfars.bls.gov>

WEB ID: 100000000001

PASSWORD: Zz000001

This survey is authorized by 29 U.S. Code, Section 2.

The BLS-3023 form is approved with O.M.B. No. 1220-0032, in cooperation with the U.S. Department of Labor. The information collected by the Alabama Department of Labor and BLS will be used for statistical and Unemployment Insurance program purposes and other purposes in accordance with law. Additional information and instructions for this survey can be found at: www.bls.gov/respondents/ars

Please provide your response within 14 days. If you have already submitted this report, please disregard this notice and accept our thanks for responding.

Sincerely,

Emily Thomas
U.S. Bureau of Labor Statistics



0006191

Exhibit 6E ARS NVM Web Letter – Mandatory State

UTANA DEPARTMENT OF LABOR
QCEW
123 EAST STREET, ROOM A
CITYVILLE UT 12345-9999
Phone: (123) 555-8888



UNITED STATES DEPARTMENT OF LABOR
Bureau of Labor Statistics
Washington, D.C.

BLS 3023 - Industry Verification Form



Z9999-NVM-0093703 P05 T00181 *****ALL FOR AADC 030
SAMPLE A SAMPLE COMPANY
SAMPLE INC 119
SUITE 218
241 ANY STREET
ANY CITY, US 03101-1824

MANDATORY

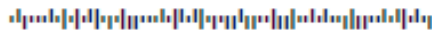

33

XXXXX XX, XXXX

Dear Employer,

Every three years, the Utana Department of Labor and the Bureau of Labor Statistics (BLS) request that you verify general business information about your firm to help us maintain accurate records. Your cooperation is essential so that we are able to produce data that are complete, accurate, and timely.

To reduce costs and save tax dollars, the Industry Verification Form has been moved online and can be completed in about fifteen minutes. To further reduce costs, the Industry Verification web system was developed alongside the existing web system for the Multiple Worksite Report, BLS-3020, which you also file for your firm.

Please use the User ID and password below to log into the secure BLS website: <https://idcf.bls.gov/>

USER ID: 100000000001

PASSWORD: Zz000119

You will find detailed reporting instructions on the back of this letter.

This survey is **mandatory** in accordance with Utana Law, Section 1 and is authorized by 29 U.S. Code, Section 2.

The Industry Verification Form, BLS-3023 is approved with O.M.B No. 1220-0032, in cooperation with the U.S. Department of Labor. The information collected by the Utana Department of Labor and BLS will be used for statistical and Unemployment Insurance program purposes and other purposes in accordance with law. Additional information regarding this survey can be found at: www.bls.gov/respondents/ars/

Please provide your response by XXXXX XX, XXXX. Thank you in advance for your cooperation.

Emily Thomas
U.S. Bureau of Labor Statistics



0002703

Exhibit 6F ARS NVM Web Letter – Voluntary State







<p>UTANA DEPARTMENT OF LABOR QCEW 125 EAST STREET, ROOM A CITYVILLE UT 12345-9999 Phone: (123) 555-8888</p>		<p>UNITED STATES DEPARTMENT OF LABOR Bureau of Labor Statistics Washington, D.C.</p> <p>BLS 3023 - Industry Verification Form</p>
<p>Z9999-NVM-0077890 P04 T00151 *****ALL FOR AADC 170 SAMPLE A SAMPLE COMPANY SAMPLE INC 155 SUITE 254 277 ANY STREET ANY CITY, US 17044-2207</p>  		
42		
<p>XXXXX XX, XXXX</p> <p>Dear Employer,</p> <p>Every three years, the Utana Department of Labor and the Bureau of Labor Statistics (BLS) request that you verify general business information about your firm to help us maintain accurate records. Your cooperation is essential so that we are able to produce data that are complete, accurate, and timely.</p> <p>To reduce costs and save tax dollars, the Industry Verification Form has been moved online and can be completed in about fifteen minutes. To further reduce costs, the Industry Verification web system was developed alongside the existing web system for the Multiple Worksite Report, BLS-3020, which you also file for your firm.</p> <p>Please use the User ID and password below to log into the secure BLS website: https://idcf.bls.gov/</p> <p style="text-align: center;">USER ID: 100000000001 PASSWORD: Zz000155</p> <p>You will find detailed reporting instructions on the back of this letter.</p> <p>This survey is authorized by 29 U.S. Code, Section 2.</p> <p>The Industry Verification Form, BLS-3023 is approved with O.M.B No. 1220-0032, in cooperation with the U.S. Department of Labor. The information collected by the Utana Department of Labor and Industry and BLS will be used for statistical and Unemployment Insurance program purposes and other purposes in accordance with law. Additional information regarding this survey can be found at: www.bls.gov/respondents/ars/</p> <p>Please provide your response by XXXXX XX, XXXX. Thank you in advance for your cooperation.</p> <p>Sincerely,</p>  <p>Emily Thomas U.S. Bureau of Labor Statistics</p>		
		

Exhibit 6G ARS NVM Web Letters – Reverse**Instructions:**

1. Log into the secure website at <https://idcf.bls.gov> using the temporary User ID and Password on the front side.
2. Follow the system prompts to set up your permanent account by choosing a new password and taking note of your new User ID.
3. Verify your contact information.
4. In the dropdown box next to 'Please select a survey,' select **the Multiple Worksite Report** and click *Continue*.

Note: Each time you log back in, you must select the Multiple Worksite Report from this page in order to continue to the Industry Verification Form. This step is necessary due to these surveys' joint web development.

5. Select your UI Account Number and click *Continue*.
6. On the following page, select the button for **Industry Verification** and click *Continue*, followed by the BLS 3023 NVM description page, where you can click *Continue* once again.
7. For any Business Activity that is incorrect, select *Edit* in the Business Activity column and follow the instructions to find the most accurate description of your business and enter a brief description of your Main Business Activity. Your firm may be engaged in other activities at other locations.
8. For any Worksite address that is incorrect, select *Update* in the Worksite column and update accordingly.
9. After verifying your Worksite Business Activities and addresses are correct, select the radio button "I verify that the main business activities listed above are correct" and select *Submit Data to BLS*.
10. The website will continue to the "Thank You" page where you can review and print your submitted data. Click the *Logout* link at the top right corner of the page and close your browser.

Note: You may have already completed your Multiple Worksite Report on paper for this quarter, but if you prefer online reporting, you can also click *Continue* to select your UI account to file your Multiple Worksite Report online. If you choose this option, you will no longer receive a paper Multiple Worksite Report in the mail each quarter. You will be set up to receive email reminders for filing this quarterly report online.

6.5 ARS and NCA Processing

When the states begin processing the new ARS, the first step is to load the Control File into the state system. Once the Control File has been loaded, states can begin loading NVM Web Responses. Since MWR Web respondents were given the opportunity to report their NVM information with their 2nd quarter or 3rd quarter MWRs, these files will be available before the Control File. States must wait and load their Control File before loading NVM Web responses. On the NVM Web response file, the master unit and reporting units (RUNs) are coded either response code 31 (pending) or response code 41 (no refiling change).

When the states were responsible for creating the mail files for the ARS mailings, all of the accounts that had responded to the ARS prior to the creation of the next print file were excluded from the file. Now that BLS creates the print files for the ARS, there is a need to account for responses received directly to the state via any method (phone calls, email, fax etc.) other than ARS Web or NVM Web. States can provide these “other than ARS Web/NVM Web response UI’s” to their regional offices for exclusion. This process is covered in the CARS Checklists on StateWeb.

The BLS provides states with a National Change of Address (NCOA) file which contains mailing address updates from the USPS. These files can be used to update on-hand addresses in the state systems. In addition, a portion of records contain a response code (RC) of 63 for records with undeliverable mailing addresses. Loading the NCOA files will update the ARS control file with a RC 63.

BLS provides states with a CARS Transmittal Schedule for NVS responses received in the ARS year. NVS and NVM Web responses will be included in these transmittals.

Some states opt to have BLS mail web letters to their unclassified (NAICS 999999) accounts. Respondents are provided with credentials to respond via ARS Web. Separate NCA response files are provided to the states according to the CARS Transmittal Schedule.

The following files are provided to the states, all file formats are included in the CARS checklist:

1. Loadable CARS NVS/NVM Response Files (.txt)

The Loadable CARS Response Files are text files that provide an ARS response code 31 (pending) or ARS response code 41 (no change) on each NVS and NVM record. When loaded, the response code fields on the records get populated in the state systems. The states must load the CARS Response Files.

2. Loadable ARS Web Data (.txt)

The Loadable ARS Web Data files are text files that include every element from the respondent supplied corrections file. Users can select which blocks of data will be

automatically loaded, rather than needing to manually enter the data. States are not required to load the ARS Web Data files.

3. ARS Web Excel Files (.xls)

a. ARS Web Response Files

The ARS Web Response File contains the same information as the Loadable ARS Web data file, but in a spreadsheet form for states to review and key in the data (if they do not load it).

b. Additional Worksite Files

The Additional Worksite File provides a listing of additional worksites that were identified by ARS Web respondents; this includes both NVS and NCA respondents. There is no automated feature to load additional worksites. States that have an “Additional Worksite Spreadsheet” file need to review and process these records manually.

4. NVM Web Excel Files (.xls)

a. NVM Web No Change Files

These files list worksites where respondents confirmed that their NAICS code is correct.

b. NVM Web Change Files

These files list worksites for which respondents indicated their current NAICS code is incorrect.

c. Address or County/Town Change

These files list UI accounts where respondents updated their addresses or CTY/TOWN codes.

d. New Worksites

These files list any additional worksites added by respondents.

5. Non Classified (NCA) Response Files :

a. ARS Web Response Files (.xlsx)

The ARS Web Response File contains the same information as the Loadable ARS Web data file, but in a spreadsheet form for states to review and key in the data (if they do not load it).

b. Loadable ARS Web Data (.txt)

The Loadable ARS Web Data files are three text files that include: address, NAICS and Geographic area updates. Users can select which files to automatically load rather than needing to manually enter the data.

Handling the ARS Web Response Excel Files (.xls)

These files mirror the loadable text files in their content but responses are made readable for state review and subsequent manual entry into a state's processing system, if they choose such an approach.

1. States can open these Excel files and review the responses for editing/keying into their EXPO or WIN-202 processing system
2. States have the option to use the *PDF Generator*; this is a Word® mail merge feature that converts the response Excel file into a pdf file that displays each UI's old and updated data on one page/screen in a fashion reminiscent of the paper NVS forms that many staff have used for years. Contact your regional office for assistance with the *PDF Generator*.

6.5.1 ARS Response Codes

Response files should be loaded throughout the ARS processing cycle. The loadable CARS files are generally made available from the national office according to the annual CARS Schedule. The ARS response codes are posted to StateWeb in the CARS section as Attachment 3 to the CARS checklists and can be found in on the QCEW cheat sheet. A full listing of response codes can be found in Appendix Q.

Below is a list of the most commonly used ARS Response codes:

- 41 Reviewed, no CCS changes (no changes to the NAICS code, geographic code, or ownership code) on a single record or subunit record. This code also applies to master records with useable ARS responses, with or without any code changes.
- 42 Employer misunderstood industry description but codes are correct.
- 46 Clean record with CCS updates from the ARS (changes to the NAICS code, geographic code, ownership code, or any combination of these codes.)

The below response code (50) indicates a code change as a result of information from non-ARS sources. These records may or may not have been in the current year's ARS.

50 Code changes from non-ARS sources. Establishments not already on the ARS Control File receive ARS Response Code of 50.

6.6 Collection Methods

6.6.1 ARS Web and NVM Web

BLS sends several email blasts followed by an initial web letter mailing and at least one follow-up mailing for the NVS. Some states are afforded the mailing of a second follow-up web letter if response rates are trailing (to single worksite units only). BLS collects NVM responses via the MWR Web. The ARS Web is also used to collect the responses for unclassified businesses (NCA). Please see section 6.4.2 for details.

6.6.2 BLS Central Review

Every year, as part of the ARS, BLS national office staff review the industry classification of selected large multi-unit firms rather than soliciting a response through NVM web. Private sector establishments included in this review are chosen by the national office based on EIN, relative homogeneity of industry codes, and size class by employment level. These EINs fall within the regular ARS selection EIN range of the year that they are centrally reviewed.

A QCEW S-memorandum is issued part way through each ARS Year detailing the Central Review procedures for that year, including information on the EINs covered in the Central Review. Goals of the review include: improved NAICS code accuracy and consistency, improved MWR information, reduction in respondent burden, and lastly, reduction in costs to the government (measured in: time spent handling responses and postage costs of Web Letter mailings.)

In recent years the Central Review process has expanded to include areas of review other than NAICS. All of the following types of review are included in the Central Review process:

1. NAICS Code Review

BLS staff review the NAICS codes of establishments for each of the EINs using information gathered from company websites, business directories, and U.S. Security and Exchange Commission (SEC) filings along with the trade and legal names, addresses, reporting unit descriptions, and employment size and wages

2. Physical Location Address (PLA) and County Code Alignment Review

BLS uses i/Lytics Post locate software to determine the county (CTY) code associated with the PLAs of establishments included in the central review. BLS compares the software-generated CTY code with the CTY codes on the EQUI files. (See Appendix V).

3. Establishment Breakout Review

BLS reviews the average employment for establishments by industry and asks states to review establishments that are outliers as possible candidates for further breakouts or NAICS code changes. For example, the company website may indicate 10 stores in a state, but only one reporting unit, with high employment, is shown. Another example would be high employment for one store location where it could be a candidate for a breakout or for a NAICS change to a different industry, such as a managing office, where that level of employment and wages would be more typically found.

4. Professional Employer Organization (PEO) Master Record Review

BLS identifies possible PEOs where the master record is not coded as a PEO (NAICS 561330).

6.7 Processing Professional Employer Organizations

It is important to clarify the treatment of establishments classified in NAICS 561330, Professional Employer Organizations (PEOs). Unlike establishments classified in NAICS 561320 (Temporary Help Services), PEOs operate in a co-employment relationship with their client companies. Some states require PEOs to report their client companies under their existing UI number.

For those states where PEOs are not required to report client companies under their existing UI the client companies of a PEO should be identified as separate establishments on the MWR and assigned the industry code based on their own primary economic activity -- not activity of the PEO. The same principle applies to the client's geographic code. Only those employees administering the core functions of the PEO are classified in NAICS 561330. Only if the state agency is unable to identify the activities of the PEO's clients for the MWR report should they report the entire employment and payroll under NAICS 561330.

6.8 Reports for BLS

Summary Management Report (SMR)

The SMR is a valuable tool in assessing a state's progress in meeting the necessary response rates for the ARS. It includes counts of records by response status as well as response rate

percentages. States should refer to the SMR frequently during the ARS Year to assess their progress.

The SMR can be produced in electronic format by the standard state processing system. This file should be submitted to the BLS regional office by the 25th of the month. BLS regional offices then review and transmit the file to the national office.

The SMR file that is generated by the state processing systems must follow the file naming convention: "AAsmrMMYY.txt"

Where:

AA is the state alpha abbreviation

MM is the numeric month

YY is the numeric 2-digit year

Appendix R gives the SMR file format.

6.9 Usable Response Rate and Total Response Rate

The Usable and Total Response Rates measure a state's progress on the ARS. The state's processing system calculates the two response rates using formulas based on Response Codes. Appendix Q lists the valid response codes and Section 11.4 discusses their effect on the CCS.

The two response rates, expressed both for units and for employment, are noted at the bottom of page 2 of the ARS and SMR reports. Separate Usable and Total Response Rates are shown for singles, subunits, and for "all." All refers to all single-unit records as well as all subunit records, since master records (MEEI 2) are always excluded from the response rate calculations. By counting subunits instead of masters, the formulas give greater weight to multi-unit respondents. The Usable Response Rate is the measure used to track a state's compliance with the Cooperative Agreement.

Usable Response Rate

The numerator includes records with the following Response Codes:

- Centrally Collected Data (32)
- Reviewed -- no CCS changes necessary (41)
- Code is correct; employer misunderstood the industry description (42)
- Clean records with CCS updates (46)
- Code change from other sources (50)

The denominator includes records with the following Response Codes:

- Included in the Refile (00)
- Updated, but has a CCS I-error (30)

- Not reviewed - Pending (31)
- Centrally Collected Data (32)
- Reviewed, no CCS changes (41)
- Code is correct; employer misunderstood the industry description (42)
- Clean record with CCS updates (46)
- Code change from other sources (50)
- Refusal (65)

Total Response Rate

In contrast to the Usable Response Rate, which represents the percentage of surveyed units with usable responses, the Total Response Rate represents the percentage of surveyed solicited units with responses, without consideration for usability or quality of the response.

The numerator includes all reporting units with these usable or unusable ARS Response Codes:

- Updated but has CCS I-error (30)
- Not reviewed - Pending (31)
- Centrally Collected Data (32)
- Reviewed, no CCS changes (41)
- Code is correct, employer misunderstood the industry description (42)
- Clean with CCS updates (46)
- Code change from other sources (50)
- Post Office Return (63)
- Out of Business (64)
- Refusal (65)

The denominator consists of all reporting units with the following ARS Response Codes:

- Included in the Refile (00)
- Accounts selected for QCEW Research Panel 1 (01)
- Accounts selected for QCEW Research Panel 2 (02)
- Accounts selected for QCEW Research Panel 3 (03)
- Accounts selected for QCEW Research Panel 4 (04)
- Updated, but has a CCS I-error (30)
- Not reviewed - Pending (31)
- Centrally Collected Data (32)
- Reviewed, no CCS changes (41)
- Code is correct, but employer misunderstood the industry description (42)
- Clean record with CCS updates (46)
- Code change from other sources (50)
- Post Office Return (63)
- Out of Business (64)
- Refusal (65)

6.10 State ARS Responsibilities

The states play an important role in the completion of the Annual Refiling Survey. States are responsible for reviewing and loading the CARS and NVM files sent from the national office. States should resolve possible code changes sent on the CARS and NVM files (establishments with a response code 31). Address changes included with the CARS and NVM files should also be reviewed and loaded or entered into the state system. State review of the CARS and NVM files includes adding those new establishments submitted on the files to their state system. States should monitor response rates and follow-up with non-respondents to confirm their information. Finally, states should work with the regional office with the review of large establishments with code changes.

From time to time states will be contacted by respondents to troubleshoot problems with the ARS Web system. FAQs for the ARS Web system can be found on StateWeb. Sometimes states will find the best solution is to take the ARS information directly from the respondent. Any questions that they are unable to answer should be directed to ars.helpdesk@bls.gov.

Chapter 7 – Collecting and Loading the Quarterly Data

State data come from employers primarily from the Quarterly Contributions Reports (QCR). QCR data are placed on the Unemployment Insurance (UI) tax file, and are then extracted to the state system. Other methods of QCEW data collection include Multiple Worksite Reports (MWRs), which collect data from multi-establishment employers, and Reports of Federal Employment and Wages (RFEWs), which collect data for Federal installations. Some data are delinquent or missing initially, so States follow up to obtain as much of these data as possible and then impute (estimate) the rest.

The overview of quarterly processing activities conducted by the state is covered in section 1.5 and the State options for the processing sequence is covered in Section 12.1. This chapter covers the Quarterly Contributions Report data, extracting data from UI, and loading MWR and RFEW data. Topics include the types of information that should be extracted, the number and timing of extracts, and MWR issues.

----- Contents of Chapter 7 -----

- 7.1 Data from the Quarterly Contributions Report
 - 7.1.1 Missing Data and Delinquent Accounts
- 7.2 Extracting Data to Match QCEW Definitions
 - 7.2.1 Timing and Frequency Issues
 - 7.2.2 Activity and Coverage Information
 - 7.2.3 Information for Inactive Employers
 - 7.2.4 Classification Codes
 - 7.2.5 Date Fields
 - 7.2.6 Ownership Transactions: Predecessors, Successors, and Mergers
 - 7.2.7 Orphans and other Multi-establishment Situations
- 7.3 Loading Data for Multi-unit Employers and Federal Installations
 - 7.3.1 Edits for Multi-Unit Employers
 - 7.3.2 Resolution of Discrepancies
 - 7.3.3 Review of Federal Installation Reports

7.1 Data from the Quarterly Contributions Report

Quarterly Contributions Reports (QCRs) are due to state UI tax departments one month after the end of the quarter. Employers submit these tax reports in various formats: electronic or on-line reporting is available in all states and is mandatory in many states for large firms. UI tax departments may also accept paper reports. Upon receipt in the UI Tax department, hardcopy reports are keypunched or scanned into the tax system. The data is available on a flow basis to the state QCEW unit which extracts the tax system information into their standard state QCEW production system.

The UI Tax department does little or no editing of contributions report data before the state QCEW unit extracts them. Employer reporting errors are present in the data extracted from the UI tax system. The comprehensive edits in the standard QCEW state systems, perform a critical function in identifying these errors for resolution by the state QCEW staff. Chapters 9 and 10 discuss editing in detail.

7.1.1 Missing Data and Delinquent Accounts

In addition to errors present in reported data, missing and delinquent data must also be addressed by the state. An employer is referred to as delinquent when no report is received. An employer has missing data when a report is received, but is missing critical data items, most commonly the monthly employment figures. The standard state QCEW systems identify fields with missing data, so state analysts are able to distinguish them from reported data fields.

Notices must be sent to delinquent and missing data employers. In most states, the UI Tax department will automatically send follow-up notices to delinquent employers. However, some UI tax departments are unlikely to follow up with those reporters who have missing data, particularly when it is employment data that is missing. In these circumstances, the state QCEW unit must follow up and generate the missing data notices. Delinquency and missing data notices are sent to employers regardless of their size. Send the notices as soon as possible after the due date or receipt of the incomplete report for the best chance for a timely response. Such follow up is critical to the overall quality of the state's QCEW data. Missing and delinquent data follow up minimizes the number of imputations generated by the state system and included on the EQUI deliverable.

All costs associated with the follow up of missing and delinquent data from quarterly contributions reports are the responsibility of the UI Tax department. If the State QCEW unit takes the responsibility for collecting missing data, they should make arrangements to be reimbursed by the UI Tax department. Costs include staff time, printing and processing of notices, and postage. Specific guidance may be found on StateWeb.

The QCEW program must assume the cost of following up for missing and delinquent data from MWR and RFEW forms.

7.2 Extracting Data to Match QCEW Definitions

Every state uses a standard QCEW state processing system and is expected to work from standard data element definitions (see Appendix B). However, the UI tax file and other data sources vary from state to state. Each state develops its own extract programs to provide the input data for its QCEW system. See StateWeb for the latest guidance on writing a new UI extract.

This section outlines the issues related to extracts. Consult your regional office if you have any questions about changing or improving your state's extract programs.

A generic “tax file” is usually referred to as the primary source for the extract. When reviewing UI data sources, states must identify specific files and options required to build the QCEW extract. File formats must be obtained and reviewed, definitions assessed, and programs rewritten to extract data for all required records and all required and optional fields, as appropriate.

Most required data are on the tax file. In some states, however, quarterly contributions data are separate from administrative or master file information. In these cases, information about ownership transactions, addresses, contacts, and liability status are on a file apart from the employment and wage data. In rare cases, employment is not added to the file with wages and must be extracted separately. Thus, in some states, extracts will have to access multiple tax files or databases to retrieve all required QCEW Data Elements.

If a state transaction file is used, identify which records/data elements are included. Consider the following issues:

- Is this a data entry file of new information and changes waiting to be loaded to the tax file or is it similar to an audit trail of changes already made to the tax file?
- Are multiple entries included for a single record?
 - If so, can they be processed in sequence to ensure that more recent information is not overlaid with older data?

In some cases, data are available from multiple sources. For instance, data may reside on a transaction file until the data are loaded to the tax file, or remain on the transaction file even after the data are loaded. Search the transaction file and verify that it contains the appropriate information; otherwise search the tax file. Due to their size, tax files are usually more difficult to search, but they often have more fields and more information than a transaction file. If the state is considering extracting from transaction files, ensure that all appropriate transactions are included. Transaction files may be more accessible but may not use any internal tax system edits or processing that would benefit the QCEW staff.

Some states maintain files for selected types of records (e.g., pending legal action, set up but not active, pending possible awarding of a business contract, receiverships to close out accounts).

Each of these types of records must be examined, based on state law, to determine if the records should be extracted and included in the state system.

7.2.1 Timing and Frequency Issues

The cooperative agreement details minimum data extracts for each production quarter. States must extract all **current quarter data at least twice each quarter. Additionally, at least one extract must include prior quarter data** received since the previous extract. Note that the prior quarter is defined as the quarter immediately preceding the current reference quarter. These extracts include all data for the current quarter, including any non-quarterly or quarterly fields that may have changed. Some states extract several times a quarter and for several quarters at a time.

Each state should work with the regional office to optimize when these extracts are run. The data source may influence the timing and the cost may influence the frequency.

If transaction files are used, it may be easier to manage the workload by loading and processing the transaction files more frequently, resulting in several smaller listings. Many states may find that an initial extract from the tax and other source files followed by succeeding extracts from transaction files provides a more efficient approach; however, this also requires additional programming.

Since current and prior data are extracted multiple times, reported data will replace estimates for many active records. It is important to remember that system edits need to be re-run with every subsequent extract.

A question to consider when programming extracts is whether previously extracted data can be distinguished from data which have not been extracted or were not available at the time of the last extract. Since at least three extracts are required for any given quarter, this means that at least three passes will be made to search for delinquent data. A few States have a field on the tax file to identify extracted data.

If the same data are extracted more than once, how are the data processed? For instance, if corrections are included in a subsequent extract, the updated information should be loaded to the state system and edited. On the other hand, if the data are re-extracted without change, these data should not replace data already on the state system. In cases where state QCEW staff may have already manually corrected the data, a new extract should not overlay the corrected data.

Complete Extracts – While covered records on state tax files are included in the extracts, some non-covered records on the source files may also be included; these non-covered records should be identified on the EQUI file. Activity Status and Type of Coverage are discussed further below and in Appendix B, Data Element Definitions.

Other issues to consider when designing extracts are:

- Which employers are covered?
- Which record types are included?
- Does the state system include all required records?
- What record type may be missing?
- How is an active account defined?
- When is an account determined to be inactive?
- How many consecutive quarters can a company have zero filled fields?
- Does the state tax file include pending accounts?
- How are pending accounts defined?
- How is missing employment identified?
- What are the procedures to solicit missing employment?
- How are delinquent accounts identified?
- What procedures are used to obtain information on delinquent accounts?
- How are zero reporters distinguished from non-reporters on the tax file?
- When and how are retroactive accounts added to the tax file?
- How can replacement data be identified on the tax file?
- When are replacement data extracted?
- Does the tax system allow the employer to provide more than one report for the account that must then be aggregated to generate a complete report? How are these augmented data reports processed?
- Does the state allow for multi-establishment identification, and if so, how?
- When and how are predecessor and successor accounts identified on the state tax file?
- How are mergers identified on the tax file?
- How are partial transfers handled on the tax file?
- Are there any imputed (non-reported) employment or wages on the tax file? How are these identified?

Coverage –If state UI law considers an account covered, the record must be included on the state extract. (For purposes of the QCEW program, “covered” refers to UI-covered or UCFE-covered.) Some states include non-covered data on the tax files. Each state has specific coverage requirements, and some states allow businesses in non-covered industries to opt-in to coverage. (See [Type of Coverage](#) in Appendix B, Data Elements.)

Only covered accounts are required in the QCEW program; however, states may opt to include non-covered accounts as well. If they choose to include them, the non-covered record must be clearly marked by using the appropriate Type of Coverage code.

Another important consideration related to coverage is the type of coverage and data maintained on the source files. If the state uses the tax file or source files as a multi-purpose file where data are maintained on UI taxes, personal income taxes, and other state taxes, it may be difficult to distinguish which records are only covered and active under the unemployment compensation laws.

Record Types – States must identify the different types of record codes included on the tax file or other source files to determine if a record should be extracted. These codes may include the following: activity status, pending codes, liability codes, reporting codes, organization types, transfer codes, data source codes, payment or billing codes, mail codes, forms codes, business activity status, and receipt dates.

There are limitations to the codes that may result in omitting records that are needed, or extracting records that should have been excluded. For instance, if a receipt date is used, only records with reported data might be extracted (i.e. delinquent accounts which should have been included would be excluded). In this case, delinquent reports would only be included if a QCR was eventually received for at least one of the quarters extracted. If the account was never received in time to include on an extract, it would never be imputed and never appear on the file. The size of the unit would not matter. A large unit with several thousand employees could just as easily be missed as a unit with only a few people.

Non-quarterly Data – Non-quarterly data fields are those fields that will only appear once on the state system although they should be updated with changes each quarter, as appropriate. Most of these fields are frequently referred to as administrative or address information. These fields include UI Account Number, Reporting Unit Number, names, addresses, initial liability date and other related date fields. The UI Account Number and Reporting Unit Number are the SESA ID or record key and cannot be modified.

Quarterly data fields, on the other hand, are fields that are filled every quarter. They include not only the economic data such as employment or total wages but also industry and geographic codes, type of coverage and activity status (described below).

7.2.2 Activity and Coverage Information

The information obtained from the Status Code, Tax Rates, and Type of Coverage is required to process each record.

Status Code – The status codes in the standard state QCEW systems are limited to three codes: active (1), inactive (2), or pending (9). The BLS system also uses code 3 for a previously submitted record that is no longer submitted and is presumed inactive.

It is possible that an “activity status” on UI files is used for a variety of situations, and a different code actually identifies records that are active, inactive, or pending.

For example, some states use status codes for an employer that owes money for delinquent UI taxes or one that has a legal action taken against it by the state. Several states use status codes to distinguish types of reporting patterns (e.g., seasonal reporter, zero reporter, special contractor, and special events). Others have an array of codes for types of inactivity or presumed inactivity.

QCEW considers a unit inactive if the business no longer has employees or pays wages. Closely examine each UI status code to determine if the record is to be included or excluded in the extract. Use definitions in Appendix B to map the state-specific codes to the ones used in the standard QCEW systems.

Type of Coverage and Tax Rates – Coverage and rating information are used in imputing, prorating, editing, and data submittals. The Type of Coverage code was expanded to distinguish between accounts with employee contributions and those with only employer payments. In addition, Federal government has a unique code, thus eliminating the need to use either the ownership code or combination of type of coverage and ownership to identify strictly Federal government data or strictly contributory accounts. These codes may match the standard QCEW system codes.

Some states maintain special records on separate files, such as phantom, suspense, or pending accounts. Each state may define these same types of records with a different name. For instance, a pending record in one state may be non-covered pending meeting a wage threshold. A pending record in another state may be active, but one in which the state has taken legal action for nonpayment of taxes that were assessed using the employer's tax rate.

The tax rate is the rate assigned to the employer based on an industry, flat rate structure, new employer designation, or experience-rating. This rate excludes any excise taxes, surcharge levels, or other amounts resulting in taxes that are not added to the unemployment insurance trust fund. Any employee tax rate must be added to the lookup file and will be submitted on the EQUI header record (described in Appendix K). In states collecting employee contributions, a single employee tax rate is used for all applicable accounts.

7.2.3 Information for Inactive Employers

The Employment and Training Administration (ETA) requires that a unit not currently reporting employment or paying wages subject to the State's unemployment compensation law, or paying no wages during the eight calendar quarters immediately preceding the current quarter be terminated, administratively inactivated, or granted permission to suspend filing Quarterly Contributions Reports (excluding seasonal accounts).

For EQUI data processing purposes, active accounts carry employment and wages. Delinquent accounts presumed still active can have the employment and wages imputed. However, UI may retain the active status of many accounts where there is no real expectation of future Quarterly Contribution Reports. In these cases, QCEW staffs should use system options to inactivate these accounts and prevent eternal processing of accounts with no employment and wages.

Here are some examples where UI does not necessarily apply an End of Liability Date, but QCEW staffs would be permitted to do so:

- Zero reporters that do not want to lose their account and tax rate because they may operate in the state again.

- Units that have stopped reporting but have not provided out-of-business dates or notifications to UI.
- Out-of-business accounts which still have financial debts or obligations to the state.
- Employers that stopped reporting but have not been audited or investigated by UI.
- Units that sold their operations but never notified UI.
- Units that purchased new operations and obtained new account numbers without transferring the previous owner's history or activities.
- Accounts that were inadvertently not processed according to the ETA requirements.

In these situations, use the date that the company ceased to have employment and wages as the "End of Liability Date".

If QCEW systems inactivate these accounts by applying End of Liability (EOL) dates, accounts can be reactivated in future quarters if any other activity occurs on the account, such as revived employment and wage reporting or the provision of an EOL date by UI. QCEW inactivation prevents any erroneous employment or wages that may be estimated by the ongoing EQUI processing of an account with no activity.

Accounts known to be inactive should only be extracted if new information is obtained (e.g., a previously unknown end of liability date is added to the file). Delinquent records still considered active on the tax file should be extracted; however, the features of the standard QCEW State system must be used to process the record. States should use the EXPO/WIN features that will inactivate a record on the micro file if it has not been reported or imputed for several quarters. In these cases, the status code is changed to two (inactive), and even though the record continues to be extracted from the tax file, it requires no processing by the State and is not submitted on the EQUI.

If this option is not used, the system will assign unique employment and wage indicators of "N" to the file to indicate that the record has not been reported or imputed for several quarters. These records will be processed through the system and submitted to BLS-Washington.

If an inactive account in UI is extracted, there must be a corresponding inactivation in QCEW. QCEW inactivates records by pulling the correct End of Liability date from the tax file. The tax file has termination, end of liability, out-of-business, closing, closed, and inactive dates. If the end of liability date on the tax file identifies when the account no longer sustained a legal or financial obligation, then this date is not the actual end of liability date for purposes of the QCEW program. For QCEW purposes, the correct End of Liability date is *always* the one that matches the last date the account had employment and wages. Review each date in the tax file to determine which most closely matches the required definition.

Other types of records, such as retroactive accounts, pending accounts, or delinquent accounts must be reviewed to determine if they are active accounts. For instance, a retroactive account may be set up for all quarters that it was active but could exclude data for quarters for which it did not meet unemployment insurance definitions as a subject employer.

7.2.4 Classification Codes

Classification codes are fields that describe the ownership, industry, or location of the record. These codes are treated as quarterly records rather than administrative, and coding standards for most of these are provided in Chapter 2. Many of these fields are initially extracted from the tax or source files and subsequently maintained through the QCEW systems. Fields include:

- NAICS Code
- Ownership Code
- County Code/Township Code
- Township Extension (a.k.a. Zone Code)
- Organization Type Indicator

Note: Many UI tax departments may change codes they deem incorrect. The QCEW program does not allow for mid-year non-economic code changes. These changes must be held until first quarter and assigned to the Code Change Supplement using the data elements discussed in Chapter 11. State QCEW staff must review and validate any such changes prior to incorporating them.

NAICS and Ownership Codes – QCEW staff assign or validate these codes when the account is set up. This information can be extracted for new units or for reactivated units if available, but must not overwrite information on existing QCEW state system accounts because these fields are maintained independently as part of the QCEW program and Annual Refiling Survey (ARS) processing requirements.

Almost all states have a process of providing a file with NAICS codes for all active accounts back to UI on an annual basis.

Location Codes – County information is required for all states and corresponds to an employer's physical location address. When new accounts are initially set up on the tax file, county codes are assigned as well as ownership and industry codes. The county code must be extracted and updated as part of routine editing, refiling, and other processing functions.

Some states use township codes (and township extension/zone code, where applicable) or other sub-county location designators on their tax files. If the data are maintained on the source file, it may be useful to extract them. It might be helpful to ask how the sub-county data are updated. If they are not maintained on the source file or in the state system, do not use them. New Jersey and the New England states are required to maintain township codes.

Organization Type Code: Several state tax systems collect codes from the Status Determination Forms of private sector establishments concerning their organizational structure. This information is used for tax purposes. These codes identify different types of partnerships, associations, non-profit organizations, trusts, estates, companies, corporations, sub-divisions, and joint ventures.

In some cases, the extract will convert the codes from UI Tax database to the standardized codes listed below. Blank-fill for Federal, State, and Local government records (Ownership codes of 1, 2, and 3). In states where Organization Codes are not used, leave the field blank.

Valid Values:

- I = Individual
- P = Partnership
- C = Corporation
- O = Other

When assigning this indicator to a master record in a multi-unit account, the state system copies the indicator from the master record to the subunit records in the same UI account.

7.2.5 Date Fields

The QCEW state system includes fields for five dates:

- Initial Date of Liability
- End of Liability Date
- Setup Date
- Reactivation Date
- Predecessor/Successor Transfer Date

The state must review all possible dates on the UI tax file or other source files to determine which dates meet the QCEW definitions as described in Appendix B and simplified above. There may be instances where additional dates have been added to the source files when that date already existed under a different name.

When appropriate dates are not extracted, the standard state processing systems can be used to assign them, or QCEW staff can manually assign them. Because subunits are rarely found on state UI tax files, the dates for these accounts must be assigned by state staff, BLS electronic MWR collection systems (the EDIC and MWR Web – both covered in Chapter 4), or state processing systems.

7.2.6 Ownership Transactions: Predecessors, Successors, and Mergers

In many states, the QCEW definition of a predecessor/successor situation does not match the legal UI definition of an ownership transaction. The QCEW program defines a predecessor/successor relationship as one where the successor performs similar operations to the predecessor using some or all of the predecessor's employees. These operations are frequently but not necessarily performed at the same location as the predecessor.

In some states, UI considers the buyer a successor account only if legal and financial liabilities and status are transferred (i.e., debts, trust fund balances, and experience-rating). In other cases, the account is transferred at the option of the buyer and seller.

Caution: While predecessor or successor UI account numbers are usually present on the UI tax file (or other source files), the corresponding predecessor or successor reporting unit numbers are typically not available. Whenever this occurs, the predecessor/successor RUNs must be set to zero initially, during the extract. Later, after researching the transactions, QCEW staff can enter specific predecessor or successor RUNs as needed. In some cases involving changes to the reporting level, QCEW staff may set predecessor/successor RUNs to all nines (99999). There are even situations in which staff may set Predecessor or Successor UI numbers to all nines. This is discussed in detail in Section 5.2.

7.2.7 Orphans and other Multi-establishment Situations

Most States do not store individual multi-establishment worksites on the tax file. For those that do, the RUN assignment may not be the same as required for the QCEW program. In these cases where a multi-establishment employer sells or closes all but one worksite, the remaining UI worksites must be dropped, and the data from the QCR must be reported using RUN “00000.” Any orphaned or single worksites with the UI and a RUN greater than zero will fail the micro edits because this does not follow QCEW reporting requirements.

Locking Fields to Prevent Changes

Each standard QCEW system has procedures for locking selected fields. State staff must lock fields when the State UI tax system does not follow the same guidelines as those required by BLS or when QCEW has the more current data. For example, states may lock updated physical location addresses in order to prevent them from being overwritten. Each system also has a mechanism to compare extracted data against locked data to manually determine if changes are needed. Review the State system documentation for specific details.

Unlocked Quarters on State and BLS Files

For those quarters that are unlocked in the BLS national system, as described in Section 12.2.3, all state system corrections impacting employment and wage data must be included on the EQUI and submitted to BLS.

Prior and current quarters must be extracted from the tax file or other sources. Previous quarters can be extracted, but this is rarely required by BLS. Data can be extracted from UI for any and all quarters in history, but BLS will only accept and edit data for open quarters. New information (information since the last extract) is accepted for active accounts, retroactive or reactivated accounts, reported data for delinquent accounts, and corrections. These changes must

be made in the state QCEW system so they will be included on the EQUI file that is forwarded to BLS.

Retention of Deleted Records

Deleted data are held in the system in case there is a need to restore the information at a later date. These records are marked as deletes and their status codes are changed to “2” (inactive) for any unlocked quarters.

The EXPO state system retains deleted records until each of the last six quarters and the current quarter has a status code of “2”. Once this time period is met, the deleted records are rolled off the file. The WIN State system will retain the record indefinitely or until older years are removed.

7.3 Loading Data for Multi-unit Employers and Federal Installations

State staff are responsible for entering data from MWRs, since this information is not normally available on the UI tax file. As explained in Chapter 3, the MWR provides disaggregated data for the individual worksites included in the total for the UI account (the total data for the employer, as reported on the Quarterly Contributions Report).

Increasingly, MWR data are collected/processed by the EDIC and MWR Web and provided to the states electronically, as described in Chapter 4. The standard state processing systems provide the means to directly load MWR data files provided by the EDIC and MWR Web to the state systems. When the MWR data files contain new reporting units (new worksites) for an existing multi-unit account, the state processing systems will create the appropriate new records on the state system, including new RUN number assignments.

7.3.1 Edits for Multi-Unit Employers

The standard state systems add the employment and wage data reported on the Multiple Worksite Report, and compare the totals obtained to those on the contributions report. If there is a discrepancy between these sets of data, the system assigns edit flags as described in Section 9.4. The QCEW staff will determine whether the difference makes up a significant proportion of the total for the employer or for any of the industry and county combinations where these data will be reported. Other Level 8 edits verify the proper reporting configuration for multi-unit employers, including Multi-Establishment Employer Indicator (MEEI) codes, Reporting Unit

Numbers, and so on (as described in Chapter 3). As mentioned in the previous section, single or "orphaned" worksite records in a multi-unit account will fail these edits.

7.3.2 Resolution of Discrepancies

If further investigation is warranted, follow these procedures to resolve the discrepancy.

First, check to make sure that data for each establishment listed on the MWR have been included on the state system and have been keypunched accurately. If the keypunching is verified as complete and accurate, then consult other sources until the discrepancy is resolved.

One source of information is the employer. Sometimes different offices within the firm complete the MWR and the QCR. Contacting these offices may resolve the discrepancy.

This does not apply to data received from the EDIC. Individual state offices must not contact employers that report MWR data to the EDIC, but submit questions to the EDI Center instead. Note that the prohibition on contacting EDIC MWR reporters covers only MWR-related questions/issues, states can contact these employers for other reasons (to obtain correct NAICS code information, for example).

Another source of information available in most states is the wage record for the employer. This document or file lists the total wages for each person employed by the firm during the quarter. The wage record is only useful for this purpose if the establishment where the employee works is identified. In the event that the wage records can be used to derive establishment totals, compare these totals with the data on the Multiple Worksite Report. One limitation of the wage record is that it includes information for all employees of the firm for the quarter, not delineated by month, and not just those employed during the pay period that includes the 12th of the month.

Other possible sources of information on multi-unit employers are reports describing work stoppages or layoffs. Large company events tend to make the local news.

After discrepancies between the data reported on the Multiple Worksite Report and on the contribution report have been resolved, taxable wages and contributions must then be imputed. (See Chapter 8 for procedures for imputing taxable wages and contributions.)

7.3.3 Review of Federal Installation Reports

Employment and wage reports from Federal installations must be screened for completeness and entered onto the state system for editing, similar to the same way UI data are edited. However, Federal data are exempted from some edit conditions (for example, the checks for missing physical location address). MWR and RFEW data received from Federal installations must be processed in the same manner as other MWRs described at the beginning of this section. Note

that some Federal data are provided electronically by the EDIC as described in Section 4.6.) Reporting requirements for Federal installations are stated in Section 3.6.

Chapter 8 – Imputation of Missing and Delinquent Data

When employers do not provide complete and timely data, imputed (estimated) data are used instead. This chapter describes in general terms how the standard state processing systems (EXPO-202 and WIN-202) impute economic data that are missing or delinquent. The formulae used by the state systems are described in detail in Appendix J. Not all formulae included in Appendix J are used by both systems. Even though imputed data are computer-generated, state staff should edit and review the imputations and revise them where appropriate. When reported data become available, the state should replace the imputed data on their file.

----- Contents of Chapter 8 -----

- 8.1 Overview of Data Imputations
 - 8.1.1 Follow-ups of Incomplete and Delinquent Reports
 - 8.1.2 Types of Imputations
- 8.2 Determining How Long to Impute Delinquent Records
- 8.3 Imputing Missing and Delinquent Data
 - 8.3.1 Guidelines by Data Element
 - 8.3.2 Multi Establishment Reporters
- 8.4 State System Options
- 8.5 Imputation Codes and Indicator Flags
- 8.6 Reviewing Imputations
- 8.7 Replacing Imputations with Live Data

8.1 Overview of Data Imputations

Within five days of the end of each quarter, employers or their reporting agents are contacted to report Quarterly Contributions Reports (QCRs), Multiple Worksite Reports (MWRs), and Reports of Federal Employment and Wages (RFEWs) data. For the purposes of this chapter, any reference to MWR should include not only the collection form but also MWR Web collection, MWR Print Contractor collection, and EDI collection. The completed reports are due 30 days after the end of the quarter. Data from submitted QCRs are entered onto the Unemployment Insurance (UI) tax file and subsequently extracted and loaded to the state system. Typically, state staff loads or enters data from the MWR and RFEW forms directly to their state system. Some multi-unit employers report their MWR data to the Electronic Data Interchange Center (EDIC) rather than to the state, as described in Chapter 4 – Multiple Worksite Central Reporting. The EDIC provides files of these MWR data to the states, and the files should be loaded directly to state system.

Sometimes data are missing (the employer omitted some data elements) or delinquent (the form is not received in time to use for file deliverables or to meet program needs). Missing and delinquent data must be imputed. Imputation is a process that enables the states to use estimated data when the actual data are unavailable. It is based on the assumption that historical trends are still valid and can be used to effectively estimate current data.

8.1.1 Follow-ups of Incomplete and Delinquent Reports

After information from the submitted QCRs is entered, the accounts should be screened mechanically for missing data. It is important that the UI tax file systems be able to distinguish between zero-reported data and missing data. This may be accomplished by indicator codes, date fields, or other mechanisms. If it is not possible to make this distinction, notices may be sent to accounts that already reported zeroes, or data may be imputed for UI accounts that correctly have zero-filled data fields.

Request notices for missing data should be computer-generated for all QCRs with missing data. The state should send these requests to every employer who submitted an incomplete quarterly report, regardless of size or the amount of reported wages. The state should send the requests as soon as possible after receiving the incomplete reports. This allows the employer's time to submit amended data. Once the state receives the missing data, these data should be entered to the UI tax file and extracted to the QCEW state system.

All costs associated with the collection of data missing from employers' Quarterly Contributions Reports are the responsibility of the UI tax unit. If the research unit is responsible for collecting these missing data, they should arrange to be reimbursed by the UI tax unit. Costs include staff time, printing, processing of notices, and postage.

Most data for Federal government installations, as well as some reports for multi-establishments, are collected through the EDIC. The EDIC will resolve any reporting problems with accounts they handle, as described in Section 4.4. The state research unit is responsible for obtaining any

missing data from MWRs and RFEWs that are not collected by the EDIC. The research unit must assume the cost of missing data follow-ups on incomplete MWRs, as well as those rare cases of missing data follow-ups for RFEWs.

Both the EXPO and WIN-202 state systems use indicator flags to distinguish between reported and missing data. The indicator flags are listed in the Indicator Flag table at the end of Appendix J – Imputation Formulas.

About six weeks after the end of the quarter, the UI tax file should be scanned for delinquent accounts. The UI tax unit is responsible for determining which UI accounts are active and delinquent, while the QCEW unit is responsible for determining if MWRs and RFEWs are delinquent. The UI tax unit should generate and mail delinquency notices for all delinquent QCRs. The research unit is responsible for collecting data for delinquent MWRs and RFEWs. The EDIC is responsible for obtaining delinquent reports from those accounts that it handles. A second notice, if necessary, should be sent eight to ten weeks after the end of the quarter.

In addition, the research unit should monitor the delinquency of large QCR respondents. If the UI tax unit does not successfully follow-up for missing data or missing QCRs on a consistent basis, the research unit should initiate follow-up with the non-respondent. A telephone call can determine if an employer is no longer an active business or has moved. For large employers who are still active, the research unit can collect missing data by phone.

As with the collection of missing data, all costs associated with the follow-up for delinquent employer Quarterly Contribution Reports are the responsibility of the UI tax unit. The research unit must assume the cost of follow-up for delinquent Multiple Worksite Reports and delinquent Reports of Federal Employment and Wages. Costs include staff time, printing, processing of notices, and postage.

8.1.2 Types of Imputations

The standardized state systems generate micro level imputations for the following situations:

- A delinquent account that last reported within a parameter-controlled number of quarters (typically two).
- A delinquent MWR (represented by the subunit records) when the account's QCR (represented by the master record) was reported.
- A delinquent QCR and MWR when the account's last reported QCR was within the last two quarters.
- A delinquent QCR when the account's MWR was reported.
- An MWR Web respondent starts the report but does not finish, leaving at least one worksite blank.

- Missing current quarter employment when current quarter Total Wages were reported.
- Missing at least one month of employment when at least one is reported.
- Missing current quarter Taxable Wages or Contributions when current quarter Total Wages were reported.
- QCR and MWR data that were already imputed when new data were received that replaced the missing data for one or the other

The systems will not impute for the current quarter in the following cases:

- An inactive account.
- An account that did not report for a parameter-controlled number of quarters (typically two).
- An imputation that is not allowed by the program parameters.
- An account that is fully reported.
- A subunit that does not have a matching master record.

8.2 Determining How Long to Impute Delinquent Records

If a report was not submitted for the two previous quarters and a report has not been received for the current quarter, the state system does not automatically impute an account for the current quarter. Instead, it flags this account for review by the research unit. UI accounts which are delinquent for two or more quarters should be contacted by the UI tax unit, if necessary, to determine if they are still active. Only if they are still active should the research unit prepare imputations for these accounts.

The research unit should carefully monitor nonresponse and imputation for larger employers. *Missing data for large employers may cause inaccuracies or revisions in QCEW data -- both employment and wage data and measures coming from the LDB.*

An important goal is to minimize the number of accounts for which imputations have to be made. A number of factors can influence the number of accounts to be imputed and how long these accounts are imputed. While many factors influence nonresponse, some of these factors are under control of the research unit, and some are not.

The states should regularly review their operations to consider the following factors:

- State QCR Collection Method.
- Increased use of electronic medium to collect data
- Use of well-designed UI forms or internet/online reporting systems with clear instructions.
- The proper use of scanning equipment to ensure accurate data entry files.
- Timely identification and review of predecessor/successor ownership transactions and linkages to prevent or reduce the number of inappropriate imputations for predecessor accounts.
- Use of reporting penalties to discourage delinquency.
- Use of interest charges to encourage timely payment of contributions.
- Adjustments to tax rates in response to late or problem reporting.

Also, please remember: **imputations for delinquent accounts should not be made automatically from previous imputations for an extended period.** Such a practice compounds errors from previous quarters. However, since it may be difficult for UI tax units to resolve delinquency problems and determine if the account is still active (or has a successor), it may take a couple of quarters of imputations before the reporting problems are addressed. It is also acceptable to incorporate imputations for the current quarter of one data type (e.g., Total Wages) in imputing another missing data type (e.g., Taxable Wages) for the sake of consistency within the quarter.

Meanwhile, if a reporter submits an incomplete report, it is acceptable to impute the missing data item(s) for that record even if the data field was not reported for the two prior quarters. Since some data are reported, it is likely that the employer is still active. Unfortunately, some employers tend not to report employment even though they do report wages.

Imputations should be replaced on the state system when actual data are received and edited. At first glance, real data that are several quarters old may seem to be of limited value. However, reported data are critical to longitudinal studies, and data replacement can be useful for future imputations, particularly if an employer often reports on a lagged basis.

States need not extract actual data from accounts older than the BLS's correction policy. See Section 12.2.3 for more details on the correction policy.

When the state research unit has confirmed that an employer is still operating, an imputation is required for inclusion in the state system and subsequent EQUI submittal, even when the employer's data are more than 12 weeks delinquent. Every effort should be made to collect current QCR data from these employers if their employment level exceeds 100. After addressing the largest delinquencies, state staff should follow up on other critical reports.

Imputation Exceptions

Exceptions are allowed in several states for domestic employers (NAICS 814110) and for some small units where legislative changes provide for annual reporting. For employers falling under these exceptions, state systems allow data to be imputed for three continuous quarters instead of just two.

8.3 Imputing Missing and Delinquent Data

Imputation formulae used by the standard state systems are listed in Appendix J along with examples for each formula. For most data fields, multiple formulae exist that may be used based on the availability of historical data or related data.

The imputations calculated from the formulae are usually reasonable, but there are numerous situations that cannot possibly be anticipated in the mechanical imputation process. Hence, an analyst's knowledge of the limitations of the formulae in various situations becomes essential in reviewing the validity of the mechanically-generated data.

Large imputed records that turn out to have been reported under a different UI account (predecessor-successor linkages) or reported for a firm that has actually gone out of business can cause substantial inaccuracies in QCEW data. Subsequent corrections could result in significant revisions and may also affect data coming from the Longitudinal Database. In addition, inaccurate imputations affect other economic data series, such as the state's CES and LAUS benchmarking processes. To reduce the impact of erroneous imputations, **states should review all records with imputed employment levels of 100 or more.** If corrections are necessary, they should be made prior to the EQUI submittal.

8.3.1 Guidelines by Data Element

The standard formulae used by the state systems will yield inaccurate imputations when the past employment and wage data used in the calculations represent economic aberrations. In these cases, the standard formulae's chief assumption – that previous patterns will recur – does not apply. Similarly, the standard formulae may miss critical current economic changes that differ from historical patterns in the data. In still other cases, it is possible that there is not enough historical data to use the formulae. Alternate formulae are listed in Appendix J to compensate for inadequate historical data.

The standard formulae are based on the assumptions and explanations mentioned above. This section includes suggestions and exceptions that analysts should consider when reviewing the imputed data for monthly employment, Total Wages, Taxable Wages, and Contributions Due.

Guidelines for Monthly Employment

1. The formulae in Appendix J are most effective for large accounts (for example, accounts with Average Monthly Employment, or AME, of 50 or more) with five quarters of previous data.

The over-the-year change formulae are clearly inappropriate if five quarters of data are not present. For these cases, copy the third month of the previous quarter to all three months of the current quarter. If any month of the current quarter is reported, review the record to determine if the remaining months should be zero-filled or imputed.

2. In cases where some but not all months are reported, imputations should be calculated from the most recently reported month. For instance, if the first month employment for the current quarter (M1c) is three times the third month employment of the prior quarter (M3p), and the data for M2c and M3c are missing, then the report may have been filled out incorrectly by the employer. It is quite possible that the respondent took the total of all three months in a quarter and placed the sum in M1c. An analyst should not automatically impute M2c and M3c from M1c in this case because the initial error will be compounded. The analyst should use both judgment and alternative sources of information to assess the validity of the reported value of M1c. However, if M1c is the only data item in the current quarter and it appears reasonable in light of past trends, then it may be reasonable to project M1c for the second and third months as well. On the other hand, it may be reasonable to leave the last two months zero-filled if it appears the unit is being inactivated. Since the EXPO and WIN systems will attempt to impute these data, those imputations that flag on edit output should be reviewed for their reasonableness and consistency with historical data or other data within the county-ownership-industry macro cell.
3. Aberrations in monthly employment could stem from a variety of unusual economic factors (e.g., supply bottlenecks, seasonal demand, strikes, etc.). States may want to consult comments from prior quarters to help explain current employment patterns. Phenomena such as adverse weather conditions or fire damage could explain the existence of incomplete and delinquent reports.
4. Delinquent accounts that are known to be both active and seasonal should be imputed using seasonal formulae. If these do not work, then it is possible that the historical data no longer represent the current seasonal patterns of other units within the same cell.
5. When Total Wages are reported and employment levels are missing, an analyst can use the reported Total Wages data to assess the reasonableness of the employment imputation(s).
6. Review employment imputations for large employers carefully. Verify that the employer is still operating and attempt to collect the data by phone. Validate that the account is not part of an undetected predecessor/successor ownership transfer.

Guidelines for Total Wages

1. In the absence of five quarters of back data, copy the previous quarter Total Wages to the current quarter.

If the prior quarter of an active non-seasonal account has been imputed, and if efforts have been made to contact the firm for Total Wage information for current and previous quarters without success, then repeat the most recent reported Total Wage value for current Total Wages.

2. Skewed historical Total Wages can result in distorted imputations. Relevant examples include changes in labor costs (e.g., a negotiated wage increase) that took place in a prior

quarter or year, but are not scheduled for the current quarter. Unscheduled bonuses or raises could also distort a Total Wage imputation.

3. In reviewing Total Wage imputations when current quarter employment data exist, evaluate the validity of the imputation by comparing the relationship between Total Wages and reported current employment levels. If a consistent relationship between Total Wages and employment levels has been established in previous quarters, then this relationship should be maintained by imputations for the current quarter.
4. Imputed Total Wages for large employers should be carefully reviewed.

Guidelines for Taxable Wages

1. The ratio between Taxable and Total Wages in the current quarter will presumably equal the ratio of the same quarter one year before. However, many factors affect Taxable Wages such as changes in taxable wage basis, tax law changes, and employment changes. Therefore, review Taxable Wage imputations carefully.
2. If employment and Total Wages are reported for an account while Contributions and Taxable Wages are missing in contrast to previous quarters, then investigate the possibility that the account has switched from non-reimbursing to reimbursing.
3. With an uncharacteristic hiring of large numbers of employees late in a prior year (e.g., the third or fourth quarter), the Taxable Wage to Total Wage (TAXW/TOTW) ratio becomes higher than usual. This distorts the imputation of the TAXW/TOTW ratio for the current quarter and year. Taxable Wages will be higher than normal because the paid annual income of the new employees will not have exceeded the taxable wage base.
4. The imputation for Taxable Wages should generally not exceed the Taxable Wage base times the Average Monthly Employment for the current quarter (AMEc).
5. Taxable Wages should never exceed Total Wages in any quarter.
6. If a state changes the Taxable Wage base, the effectiveness of Taxable to Total Wage ratios will diminish between these years. Hence, analysts may make adjustments in the TAXW/TOTW ratios when Taxable Wage bases are different between years and manual imputations are needed.

Guidelines for Contributions Due

Compute contributions by multiplying the Taxable Wages, whether reported or imputed, by the account's Tax Rate. If the account is a multi-establishment reporter, use the same Tax Rate for all units of the account when generating contributions.

8.3.2 Multi Establishment Reporters

Two reports are received each quarter for multi-establishment reporters: a QCR and an MWR (multi worksite report). When either report is delinquent or incomplete, imputations or prorations may be required.

The QCR (the master or “parent” summary) provides the sum of employment and wage data for all related worksites. When the QCR is delinquent but current worksite data are available from an MWR, MWR web, MWR Print Contract, or the EDI Center, QCR data can be derived by simply summarizing worksite data.

Prorations

Alternatively, a current QCR may be available when the MWR, MWR web, MWR Print Contract, or the EDI Center data are delinquent or missing critical data. In this case, the state can derive worksite data by applying previously derived ratios to current QCR data. These derived data are referred to as prorations.

When a QCR for a multi-unit account has been received, but the corresponding MWR, MWR web, MWR Print Contract, or the EDI Center data are incomplete or delinquent, the state should first contact the employer and attempt to obtain the current worksite (subunit) information. If the data are not available for the missing worksites, the formulae provided in Appendix J are performed by the EXPO and WIN systems to prorate detailed employment and wage data.

When part of the MWR data are reported but the rest of the rows are missing, the state systems’ attempt to apply the unaccounted balance of the master to the remainder of worksites. For example, a multi account has five worksites but only three are reported. The sum of the three reported worksites are summed for each employment and wage field. That sum is subtracted from the reported or imputed master. If the remainder is still positive, the remaining two worksites are distributed from it.

Proration Problems

When the employment and wage ratios of individual units to the master account are stable from quarter to quarter, the proration procedure is quite reliable and MWR data can be prorated from reported QCRs indefinitely; however, the longer these prorations continue, the less reliable the data become.

For example, when worksites open or close, the number of units comprising the multi-unit account will change. The distribution of employment and wages across the new firm structure may change as well. In this case, prorations become less reliable. Particularly for large master accounts, states should contact the respondent and obtain current subunit data when they become aware of a significant worksite opening or closing. The state reviewer should examine subunit prorations and attempt to obtain reported MWR data on at least an annual basis.

The prorations may also become unreliable when seasonal or economic trends differ across the subunits. In addition, seasonal industries present a special problem since the unit-to-account ratios may be subject to seasonal change as well. EXPO allows its users to seasonally prorate online. These prorations use the ratios of year-ago data for each worksite over the sum of all active year-ago worksites applied to the current data to seasonally distribute the master data.

It is imperative that the state thoroughly evaluate questionable prorations and, where appropriate, modify the results prior to EQUI transmittal.

Taxable Wages and Contributions

Taxable Wages and Contributions are not collected at the worksite level on the MWR, but instead are derived using current data from the QCR. Similarly, the Contributions are also distributed based on current quarter Taxable Wage ratios.

Federal Reporters

Typically, imputations for missing data from an incomplete or delinquent RFEW use the same methodology as those used for private sector multi-establishment accounts. Since Federal government data are not reported on QCRs, the missing master record data are imputed using the single-establishment methodology. These imputed master record data are then distributed amongst the multi-establishment subunits. Taxable Wages and Contributions Due for Federal government accounts are always equal to zero.

Prorations

If **both** the QCR and MWR are delinquent, impute the QCR using the single unit methodology and then prorate the data for the multi-establishment subunits. Because the prorated data are based on an imputation, the derived worksite data are also considered imputations.

Taxable Wages and Contributions are not collected at the worksite level on the MWR, but instead are derived using current data from the QCR. This means that when the QCR is delinquent or does not include data for Taxable Wages and Contributions, the worksite detail must be prorated from an imputation. The state must first impute Taxable Wages and Contributions for the master record using the single-establishment formula. Then the state can prorate the imputation to derive worksite imputations. Similarly, contributions can be imputed for each unit by multiplying its Taxable Wages by the account's tax rate.

Multi-establishment subunits whose data are generated from a **reported** QCR are treated differently than those whose data are generated from an **imputed** QCR. Those from reported QCRs are referred to as prorated and are not considered imputed since they are derived from current quarter, reported data. Prorations based on imputed QCRs, however, are considered imputations.

8.4 State System Options

The EXPO User and Technical Documentation or the WIN-202 Documentation should be referenced for details on system options for each imputation processing. Several possible options exist when running these jobs. Depending on which system is used in the state, it may be possible to run the following:

- Separate jobs to sort imputed records by size and type of imputation (using indicator flags).
- Separate jobs for multi-establishment prorations from single account imputations.
- Separate jobs for missing employment from delinquent accounts.
- Separate jobs for each of missing employment, multi-establishment prorations, and delinquent accounts.
- Separate jobs for imputations from edits or combinations of edits and imputations.
- Online, individual record or multi-establishment family imputation.
- Separate jobs or queries to identify imputed large establishments for detailed review. Reviewing edit 099, *Questionable Large Imputation*, will also identify the large imputations without having to run an additional query.

Imputations can be run at any time in the processing cycle once the quarters are rolled and the reference quarter is the system's current quarter. The earlier in the cycle that imputations are generated, the more imputations will be generated for the state system. Since states should be attempting to obtain missing and delinquent data, it is possible that some of the imputations will be reviewed by analysts and later replaced with live data.

Running imputations late in the cycle allows additional time for data collection of previously missing or delinquent accounts. Running them too late in the cycle, however, may not allow adequate time for their proper review. States should run imputations early enough to allow adequate review time for large employer imputations.

Imputations can also be rerun if the analyst feels that partial data may have been received that would affect the quality of the imputations. Keep in mind that if the imputations are rerun, they should be reviewed or checked afterwards for any significant problems or fluctuations.

8.5 Imputation Codes and Indicator Flags

Each standard state system assigns an Indicator Flag to all employment and wage data items to indicate their source. An additional code is generated and displayed for state review when imputation or proration is attempted for a missing data field.

Imputation Report Codes

Imputation Report Codes describe either the formulae used for successful imputation, or the type of failure the system encountered during imputation. These Imputation Report Codes are not stored, but are displayed on the imputation reports as a useful tool for state review.

When an imputation is successfully generated, the Imputation Report Code is a three-letter alpha abbreviation of the field (e.g., EMP for employment, TOT for Total Wages, TAX for Taxable Wages, and CTB for Contributions) followed by a number designating the formula that was used. For example, TOT4 is the code for Total Wages that were successfully imputed using the fourth formula for Total Wages, $TotW(cq) = TotW(pq)$. These codes are listed and defined at the end of Appendix J in the table entitled Imputation Report Codes: Successful Imputation Codes.

If the system could not generate the data, the three-position abbreviation of the data field is followed by one alpha character indicating the last formula attempted. For example, TOTD means that Total Wages were not imputed because of an imputation error for the master account. The full list of these codes and their definitions appears in the table entitled Imputation Report Codes: Imputation Failure Codes, also in Appendix J.

Imputation codes are *not* stored in the state system. They are only displayed for reference on the successful imputation and failed imputation reports generated as part of the imputation runs.

Indicator Flags

In contrast to Imputation Report Codes, Indicator Flags are stored for each Monthly Employment, Total Wage, Taxable Wage, and Contributions data field on the state system. These indicator flags are also submitted to BLS on the EQUI file. The indicator flags are listed and identified in the Indicator Flag table at the end of Appendix J.

As the state initializes a new quarter in their processing system, the Indicator Flag for all collectable data fields on the state system is set to “M” (missing). As actual data arrives and are entered via online entry, Input Micro Transaction (IMT) files, EDI load programs, or other batch routines, the indicator flag changes from an “M” to an “R” (reported). The indicator flag can be used to identify late reports (“L”) or data collected in response to missing data notices (“D”) if manually entered. The IMT extract is the only extract where the extract can be designed to set the indicators to L or D if they are known to be from late respondents or missing data notices but this is not typically done. Note that if a particular data element was never reported, imputed,

prorated, or changed, its indicator flag will remain M – whether or not the *entire* account (the QCR) is delinquent.

Indicator Flag values also indicate when data are imputed or derived through proration. These flags are useful to monitor workload associated with nonresponse and imputation. Indicator flags are also useful for state data collection management. They can also be used to assess data quality -- how much of employment is reported versus imputed -- or possible areas of improvement. For example, if the state is finding it necessary to override system-generated imputations with manual corrections, the imputation formulae may need review and improvement. Other codes, such as those used to identify data obtained as a result of sending missing data notices or delinquency notices, are useful for evaluating the workload associated with collecting late data. This may indicate that forms changes are needed, that better public relations and education about the value of the data may be needed, or that the requirements may need to be modified.

8.6 Reviewing Imputations

Failed imputations (when the system could not successfully generate an imputation from the programmed formulae) should be reviewed for employers of all sizes. If live data cannot be collected and the record must be imputed, the state may have to manually create the imputation in lieu of a system imputation.

System-generated and manually-produced imputations should be processed through micro edits and integrated (macro) edits. This ensures that the data are reasonable and consistent with historical data and with the data of other employers within the cell.

The state should review all records with imputed employment levels of 100 or more prior to EQUI submittal. If corrections are necessary, they should be made prior to submitting the EQUI. See additional information on large employers below.

During the review process, analysts should draw upon additional resources to assess the quality of imputations. Industry patterns across the state, or more current industry data from the Current Employment Statistics program, can be used to review the reasonableness of imputations. At the employer/worksites level, the analyst's familiarity with the particular account is an important input to evaluation. Using outside sources of information -- other local indicators and media -- may be helpful in arriving at more meaningful estimates.

When actual data are received, they should be reviewed and replace the mechanically-generated estimates.

Problem Areas

Several problems can occur when imputing data. These issues are discussed below for large employers, new units, predecessor/successor units, discontinued units, prior data with an unusual trend or atypical seasonality, and partial imputations. Large employers are also mentioned in the other subtopics as helpful.

Large Employers

Large employers (with employment of 100 or more) merit additional attention and scrutiny since these imputations can create critical errors in the QCEW data. Subsequent corrections could result in significant revisions and may also affect data coming from the Longitudinal Database. In addition, inaccurate imputations affect other economic data series, including the state's own CES benchmarking process.

When missing or delinquent data are imputed for these employers, the state should carefully review the employer's status to verify that the business is still operating and that a change in ownership has not resulted in accidental double counting. If an imputation is required for a large

nonrespondent, the state should give the imputations careful review in light of current economic trends and seasonal fluctuations.

New Units

Most imputation procedures rely on historical information; therefore, it is very difficult to impute data for new units with no reporting history. When reviewing imputed data for new accounts, always consider the following:

- Check the Initial Date of Liability to ensure that data are not being imputed for a time period when the account is not yet active.
- Check the status determination form for information on anticipated employment.
- Check wage records reported separately.
- Contact the employer for information, particularly if the new unit is expected to employ a large number of people.
- Check the Internet and other media sources.
- Consider using industry averages derived from similarly classified units.
- Determine if the unit is a successor and use information from the predecessor unit.

Predecessor/Successor Units

It is important that the UI tax unit or the research staff identify units that were sold. If the unit was sold, imputation for the predecessor would create an employment over count because the imputed data on the predecessor duplicates the employment and wages paid on the report of the successor. Predecessor/successor edits may identify this error, or the error may be reflected in integrated macro edits when it causes an abnormal significant increase.

It is critical that **either** the predecessor's or the successor's data be on the file. If neither the predecessor nor the successor reports, and data are not imputed, then an employment and wage undercount will result.

Predecessor/successor transactions involving large employers require thorough investigation to reduce possible over counts or undercounts.

Discontinued Units

It is important that the UI tax unit or the research staff identify units that no longer report or are out of business.

Unfortunately, it may take the UI tax or audit units a couple of quarters to identify these closures. For this reason, the imputation formulae usually allow two quarters of delinquency for non-reporting. This should allow enough time for the UI tax or audit staffs to contact the employer and determine its reporting status. If a record was imputed but should have been inactivated, a retroactive inactivation in the appropriate quarter(s) or setting the End of Liability Date to the

appropriate time period will change the Status Code. This, in turn, causes the system to ignore the imputed data during aggregation, in the integrated (macro) edit, and for other uses.

Note that if a unit is discontinued or an employer was delinquent and imputed for two consecutive quarters, QCEW program policy recommends that data for the third quarter not be automatically imputed by the system. (This can be controlled, to some extent, by settings in the state system.) Instead, the system may be used to list these accounts so that state staff may attempt to verify that the unit or account is still active. If it is active, then they should make a manual imputation.

The following actions should be considered in the review of delinquent accounts:

- Check the End of Liability Date or the Status Code to ensure that data are not being imputed for a time period when the account is no longer active.
- Check for a successor account.
- Contact the employer for information.
- Check the Internet.

If a subunit of a multi-establishment account is closed at the end of the prior quarter and not prorated in the current quarter, the employment and wages of the sub-unit in the prior quarter are excluded from the prior to current ratio computations so that it does not impact the remaining active subunit prorations.

Meanwhile, several State legislative changes now allow domestic employers (NAICS = 814110) to report once a year instead of each quarter. State systems allow three continuous quarters of imputation for these units.

Prior Data with an Unusual Trend or Atypical Seasonality

If the historical data of the unit are atypical, the analyst may need to manually override the imputation to compensate for the anomaly. Similarly, historical data may not accurately reflect atypical economic or seasonal changes in the current period. Additional information can be obtained from the following actions to help modify the imputation:

- Check wage records.
- Contact the employer for information.
- Check for an upcoming or future quarter.

Partial Imputations

The imputation formulae typically treat each data element independent of the other elements. There are a few cases where one data field is used in the formula to impute another data field (e.g., Total Wages are used in some of the employment formula). There are only a few situations where the absence of one data field will cause another data field to fail to be imputed. As a result, there are several instances where part of the record may be imputed but the other data field(s) are not. These failed imputation cases should be reviewed. Partial imputations will

result in missing employment or wages, create skewed average wages, and affect the quality of the data. These errors can be particularly critical when they involve large reporters.

Information Sources

Possible sources of useful information in the states include the following:

1. Comments – Analysts should examine narrative or coded comments for previous quarters to ensure that the previous data follow a typical trend. The appropriateness of seasonal formulae can be more accurately judged if the quarters or months from which the data items will be projected are not deviations from the normal trend. If an aberration occurred in the past, the imputation for the current quarter should not be calculated simply by using the general formulae. Finally, comments may point to other information sources that may help in the imputation process.
2. Upcoming Quarter Data – It may be possible to review a QCR or MWR for the next quarter. These data could then be used in conjunction with the prior quarter data to establish a range for imputing missing items in the current quarter.
3. Information Generated from Imputation Procedures – Imputation procedures should produce the following information to assist an analyst in reviewing the imputation:
 - a. A list of all accounts that are delinquent and their imputation data.
 - b. A list of each account which either:
 - Reported zero-data last quarter and did not report this quarter, or
 - Did not report last quarter and did not report this quarter.
 - c. For all large (100 or more employees) delinquent and missing data accounts, a list of the imputations and the previous five quarters of data.
4. Employee Wage Records – The tally of all employees listed should equal or exceed monthly estimates, depending on turnover, seasonality, etc.
5. Layoff Reports – Reports showing the time period including the reference week may be used to revise estimates of employment and should provide an idea of why wage levels fluctuated since last quarter.
6. Predecessor/Successor Codes – A transfer in ownership may be a clue to finding a delinquent or missing report.
7. Status Codes – By determining whether a firm is active or inactive for UI purposes, it is possible to tell whether the report is delinquent or whether the firm is actually out of business.

8. Initial Date of Liability and End of Liability Date – These dates are useful when determining if the account was active for all months of the quarter, was not active at the beginning of the quarter, or was closed before the end of the quarter. Both standard state systems use these dates to adjust the Status Code for the record.
9. Local News Media – The local news media is an important source for information on local establishments, particularly the closing of large businesses.
10. Local Office Information – Analysts or other staff in the local offices should keep abreast of community happenings that impact their labor market, particularly business closings.
11. Industry Averages – As an additional tool for certain estimation procedures, quarterly industry averages of employment and wages for each industry would be useful. To impute current quarter data for a new account for which only the prior quarter's data are available, a ratio of change for the industry as a whole from prior-quarter-a-year-ago to current-quarter-a-year-ago can be applied to the previous quarter's data for the account. In addition, industry averages can be used to calculate industry trends that can then be compared to imputed quarterly changes for individual accounts.
12. Employer – The employer is generally the best source of information. The analyst can often call the employer to verify unusual fluctuations or to obtain missing information. The employer will sometimes be the only source for resolving a data problem, such as erroneous employment reporting. However, some employers will not always be cooperative.
13. Analyst Judgment - The QCEW analyst's knowledge of the state economy, especially in their immediate area, is invaluable. A senior analyst may have information regarding a data situation that occurred in the past or general information about a local company or industry that will help resolve a flagged record or failed imputation. Analyst knowledge and background information also play an important part in making judgment calls about whether a flagged record is suspicious or not.
14. Internet - The Internet can be a useful tool to obtain additional information about the reporter. Possible information may include:
 - Subunit locations
 - New locations
 - Employment levels
 - Predecessor/successor transactions
 - Mergers

General Suggestions and Considerations

Large employer imputations should always be carefully reviewed by appropriate state specialists. Consider the size of the employer when reviewing imputation formulae and alternative methods.

State analysts should keep abreast of legislative changes. They may affect UI taxes.

8.7 Replacing Imputations with Live Data

When missing data or delinquent accounts are finally reported by the employer, state staff should replace imputations with the actual data on the state system. The state system will then generate an Enhanced Quarterly Unemployment Insurance (EQUI) record for BLS. The EQUI update will replace the earlier imputations sent to BLS with the reported data, provided that the change occurs within the time frame permitted by the BLS correction policy described in Section 12.2.3. The replacement data should also be edited to ensure continued data quality.

Chapter 9 – Editing Micro Data in the States

This chapter and the next discuss using the edits in the standard state systems, reviewing edit results, and making corrections. The edits are automated: a computer processes the data, assigns edit flags according to certain conditions, and identifies flagged records. State staff then use the edit results to review, research, correct, and explain suspect data. Editing in the standard state processing systems, EXPO-202 and WIN-202, follows the national office requirements explained in detail in Appendix F (Edit Conditions and Formulas).

When state staff conscientiously review edit results, data quality improves in several ways:

- Erroneous data are corrected.
- Unusual data changes are verified and explained by a comment code or narrative.
- Reporting problems are identified and resolved.
- Data from Quarterly Contribution Reports (QCRs) and Multiple Worksite Reports (MWRs) are consistent.
- Imputations are adjusted, where necessary, to reasonably predict missing data.

While correcting erroneous data dominates the quarterly effort, verifying and documenting questionable data helps data users understand economic events and prepares for the review of future data.

----- Contents of Chapter 9 -----

- 9.1 Edit Types and Edit Levels
- 9.2 Editing for Reasonable Employment and Wage Levels
 - 9.2.1 Edits for Monthly and Average Employment
 - 9.2.2 Edits for Total and Average Wages
- 9.3 Address Editing: At Least One Clean Address
- 9.4 Multi-Establishment Editing
- 9.5 Using Wage Records in Editing
- 9.6 Using BLS Comment Codes
- 9.7 Setting the Parameters
- 9.8 Determining the Research Needed
- 9.9 Resources for Researching Suspect Data
- 9.10 Resolution of Suspect Records
- 9.11 Improving Data Quality

9.1 Edit Types and Edit Levels

The standard edits consist of several types:

- Micro edits – identify invalid or questionable data associated with individual establishments (individual reporting units).
- Macro edits – identify questionable data that have been summed to a macro cell level. Macro cells are typically the aggregation of individual reporting units in a detailed level industry, ownership, and area.
- Integrated edits – state systems and the national office process macro edits in combination with comparable micro edits. In this way, the individual reporting units that cause or contribute to the macro flag can be identified and corrected (or explained). Macro editing and the integrated edit are discussed in Chapter 10 – Macro File and the Integrated Edit.
- Predecessor/Successor edits – examine the relationship between previous and current business owners to ensure that consistent classification codes are used and to prevent data overlaps or gaps.
- Multi edits – ensure consistency within multi-establishment Unemployment Insurance (UI) accounts, including between QCR data (reported on the master record) and MWR or EDI Center or MWR Web data (reported on the subunit or worksite records).
- Wage record edits – use data from wage records as a tool to determine whether employment and wage levels are reasonable. They are performed in the state systems, if the wage records are available.

The edits are grouped into nine levels, based on the type, purpose, and severity of the error or flag. The first six edit levels are routine micro/macro edits and are ranked in ascending order according to their seriousness. In general, edit Level 1 flags are the most serious and edit Level 6 flags are the least serious. Detailed information about priorities for edit review and cleanup appears in Section 13.3.3. Edit Levels 7 through 9 are special purpose edit levels that focus on specific issues.

Individual edits are grouped within edit levels and have a unique, three-digit code assigned to them. For a small number of data elements, there is no edit code, and the edit will force invalid data to the default value without manual intervention.

I-errors indicate invalid data and must be corrected. Warning edits (W-flags) indicate a record has failed an edit because of questionable data and that the data should be reviewed for possible errors. All error flags occurring in edit Levels 1-4 are I-errors. All flags in edit Levels 5, 6, 7, and 9 are W-flags. Both I-errors and W-flags occur in edit Level 8.

For more detail concerning edit flags, see Appendix F.

The Nine Edit Levels

Level 1 – Pre-edit I-errors (edits 001-006)

Pre-Edits ensure that each record's identifying information is properly formatted as numeric or alpha-numeric, has the expected values, and can be loaded to the national office. These errors rarely if ever occur in state systems since the data elements are usually system-controlled. These edits are important in the national office to ensure that the correct state's data are loaded to the database for the correct year and quarter and are processed as instructed by the state.

Level 2 – Key Field I-errors (010-016)

Key fields (industry, ownership, and county) are essential classification fields which are most used for aggregation, sampling, and other data uses. Errors in these fields render a record fundamentally unusable.

Level 3 – Date and Status Code I-errors (021-025)

The date and status code edits ensure that the record has adequate information to properly determine its status (active, inactive, or pending). The status code and the date fields (such as initial liability, end-of-liability, and reactivation dates) are used to determine whether or not the record should be edited, refiled, aggregated, and provided to various state and BLS users.

Level 4 – Remaining I-errors (031-080)

Level 4 edits review the data elements for the following:

- Valid numeric or alpha conditions
- Valid responses from a limited set of expected values
- Valid relationships between two or three data elements

In almost all cases, these edit flags must be corrected. There are a few situations where the state systems will override an invalid response with a blank, or will zero fill.

Level 5 – Large Record Employment and Wage Edits (085-086, 091-099)

Several of the employment and wage edits are divided into significant changes (Level 5) and important but not as large changes (Level 6). This was done to help reviewers focus first on those changes that have the greatest impact on the data. Most of these edits are performed at both the micro and macro level. The micro and macro versions of the **same edit** share the same three digit code.

Level 5 edits identify:

- Significant fluctuations over time in employment or wages
- Significantly large new, discontinued, or imputed records
- Records with high wages but no employment
- Records with high employment but no wages
- Records with wages that are equal to the sum of the three months employment, if employment is large

The parameter/tolerance values used in Level 5 are greater than those used in Level 6. Because of this, records flagged during a Level 5 edit indicate a more significant employment or wage fluctuation than their comparable counterparts in edit Level 6. Though similar, Level 5 edits have different three-digit codes than their equivalent edits in Level 6.

Most of these records warrant further review, possible corrections, and usually some explanation if not corrected. Problems can be researched:

- Using wage records
- Using UI correspondences or supplemental information
- Using similar units of a multi-establishment employer, similar employers in the cell
- By contacting the employer

Level 6 – Warning (W) and Other Summed Level Edits (088 and 101-146)

The same type of edits performed in Level 5 are performed in Level 6 but with a different, smaller set of parameters. Level 6 edits identify fluctuations in the economic data (on both micro and macro records) that are smaller than at Level 5, but still significant. For example, an employment change of 50 people from one month to the next might flag at Level 6 but pass at Level 5.

Edits in this level also include most other W (Warning) edits that flag questionable data of other types (such as address fields, missing physical location addresses on large records, telephone and fax numbers, tax rate, Employer Identification Number (EIN), missing taxable wages (on experience-rated accounts), relationships between classification codes, code changes, and records that have an unclassified industry code with higher employment). While the flagged data may be accurate, they are sufficiently unusual that data users would look for an explanation.

Records flagged by these edits should be reviewed and corrected (where necessary) or explained with an appropriate comment code.

Level 7 – Predecessor/Successor edits (156-164)

Predecessor/Successor edits are designed to identify potential relationship problems between predecessor and successor units. In these cases, either the predecessor of a new or merged unit is identified and/or the successor of a partially or completely discontinued unit is identified.

Level 7 edits identify two general types of errors, code discrepancies and suspect economic data.

First, a comparison of the predecessor's and successor's data fields may show unexpected differences in one of the following codes:

- NAICS
- County
- Township (for certain states)
- Ownership

Usually, the codes of the predecessor and successor are the same unless the successor had an immediate economic code change at the time of the ownership transfer. If there was a non-economic code change (e.g., the predecessor was incorrectly coded and the successor is assigned the correct code), the change should be held until first quarter. There are two exceptions to this rule:

- The employment is 25 or less in the months immediately before and after the change of ownership, or
- The change is from an unclassified to a classified industry or geographic code.

The parameters used in these edits should exclude these smaller units. If the code change should be held until the next first quarter, follow instructions in Chapter 5.

The second type of error is an overlap or gap in reporting economic data. When both the predecessor and successor – or neither the predecessor nor the successor – reported during the reference period, there is either an overlap or a gap in reporting.

For QCEW purposes, when the predecessor and successor both have employment and wages, one of the following has generally occurred:

1. One of the units was imputed, and the imputed record should have been inactivated, or
2. Both the predecessor and successor reported, and only one should have.

To correct these:

- The predecessor should have employment and wages changed to zero, or
 - The predecessor should be inactivated for the reference period, or
 - The successor should have its employment and wages changed to zero and the record coded as pending until the appropriate quarter when it would be activated.
3. The transfer of ownership occurred in the middle of the reference period and the information should be handled in either one of two ways:
 - Merged under one unit, or
 - Properly explained using numeric or narrative comments.

If neither the predecessor nor the successor reported during the reference period, the following should be determined:

- If the business's employees continued to work during the reference period.
- And if so, who paid their wages?

The appropriate record's data should be either reported or imputed based on the data of the predecessor's last report.

Level 8 – Multi-establishment edits (171-185)

These edits review the relationships among records within a UI account, or compare the total employment or wages of the sub-unit records with the master (parent) record. These edits ensure the following:

- That the sum of the economic data from sub-units is relatively close to the amount reported for the master record.
- That each multi-establishment account (family) has a master record with at least two sub-units (worksites).
- That all members of the family have the same Ownership Code and EIN. Also, for Indian Tribal Councils, all members of those families should have the same Special Indicator value of T.

Level 9 – Wage record edits (not performed in the national office) (191-198)

These edits are a tool which can be used in conjunction with the employment and wage edits to help determine if the employment or wage change is supported by data changes in wage record data. These edits should only be run if the state can obtain and load automated files of wage record data.

Note: States using these editing tools should ensure that data for their wage records include all UI-covered employees and that wage data on wage records include adequate dollar field length for the total wage amount.

The Wage File Creator, found on StateWeb can be used to load LEHD data and obtain summary data and match pair data into EXPO and QUEST. The Win Wage Record Tool, also found on StateWeb also loads LEHD data and generates a similar file for WIN.

9.2 Editing for Reasonable Employment and Wage Levels

The data on each micro record can mostly be classified into two types: quarterly and non-quarterly or administrative data. Non-quarterly data elements include the micro file key fields (UI/RUN), predecessor and successor IDs, address-related fields, date fields, Annual Refiling Survey (ARS) fields, EIN, and other special codes and indicators. These are data elements that rarely change, or whose current value is the only one used. Quarterly data, on the other hand, include the economic data fields (employment, total wages, taxable wages, and contributions), the classification codes, Status Code, Type of Coverage, and other data elements used to generate current and historical aggregations of the economic data. The two sections that follow discuss the quarterly edits for the essential economic data: monthly employment and total wages.

Editing Effects of Shifts Between Reporting Units

At most edit levels, the standard BLS editing is applied to individual reporting units (individual UI/RUNs). The exceptions are:

- Macro edits that apply to county-ownership-industry aggregations.
- Predecessor/successor (Level 7) edits that connect reporting units using predecessor or successor IDs. The use of predecessor and successor IDs is described at length in Chapter 5.

- Multi-establishment (Level 8) edits that compare reporting units within the same UI account.

One example of a major data event that is not the result of error is the shifting of employees from one reporting unit or UI account to another. Some of these employment shifts will cause the state to consider whether to change an account from a single to a multi-unit account, a process described in Chapter 3 – Special Processing for Multi-unit Employers. The shifting of employees to and from professional employer organizations (PEOs) will also cause employment fluctuations. In the case of a PEO, the state should make every attempt to have the employment reported in the correct industry code. This situation is described in detail in Section 15.3.

Inter-quarter fluctuations may be caused by a restructuring, a change in ownership, or the breakout of a multi reporter. Indication of the latter two situations may occur in the state UI system. A distinct possibility is that the data for either the current or prior quarter are incorrect. These data must be examined and corrected based on the procedures described in this chapter.

Significant Employment and Wage Situations

Employment and wage edits are divided among two edit levels: edit Level 5 and edit Level 6. Level 5 edits flag records that have excessively large fluctuations of employment or wage levels. Because the records flagged by Level 6 edits do not have the large data fluctuations as those records flagged by Level 5 edits, they have less of an impact on the macro level data. Five edits selected for special consideration are given in the following table.

Table 9.1 - Codes and Descriptions for Edit Levels 5 and 6

Level 5 Edit Code	Level 6 Edit Code	Edit Description
091	126	Monthly Employment Change Check
092	127	AQW Change Check
093	130	Employment Without Wages Check
094	131	Wages Without Employment Check
095	132	Wages/Employment Sum Check

The employment edits are performed on any month of employment loaded to the file or corrected on the file. If multiple quarters of data are loaded or edited at one time, then all applicable quarters need to be edited. In the state system, this may require special runs of the micro edits for quarters other than the current and immediately prior quarter.

Editing Previous Quarters

The correction policy (described in Section 12.2.3), which is subject to change, includes updating older data for at least the prior quarter to improve the quality of data and to obtain

better longitudinal information. Editing and updates to previous quarter data should be made when:

- Late-reported data are extracted from the UI tax or other source files;
- Reported data replace imputations (estimates);
- Additional predecessor/successor relationships are identified;
- Retroactive records (those that were set up for the older reference period after the fact) are identified and added to the file;
- Records known to be out-of-business during earlier quarters are inactivated;
- Older data determined to be in error are corrected.

The standard state systems will accept newly extracted or updated data for *up to four quarters* earlier than the current processing quarter, although BLS recommends focusing on the current and immediately prior quarter. This is subject to change with changes to the BLS correction policy. This policy, described in Section 12.2.3, determines which corrected or updated data will be submitted to the national office.

9.2.1 Edits for Monthly and Average Employment

The primary monthly employment edit is edit code 091 at Level 5 and code 126 at Level 6. (WIN-202 uses other codes: 089-091 for each month at Level 5, and 136-138 for each month at Level 6.) This edit consists of six different tests plus an additional step (step 7) for first month processing. (Appendix F provides a detailed description, including examples.) The state and the national office systems perform this edit on each month's employment. The edit flags a monthly employment value only if the employment value fails all six tests. Whenever one of the tests cannot be performed due to insufficient data, that test is bypassed and the next test in the sequence is performed.

The edit applies six tests (one test at a time) to each month of the quarter. At the first occurrence of a successful test (provided it is one of the first five tests), the month passes the employment edit.

Beyond the first five tests, however, month 1 is edited slightly differently than months 2 and 3. If employment data for months 2 or 3 pass the 6th test, those months will pass the edit. On the other hand, if data for month 1 employment passes (or bypasses) the 6th test, then a 7th test is performed. (The edit does not apply the 7th test to employment data in months 2 and 3.) If data for month 1 employment passes the 7th test, then month 1 employment passes the edit. Otherwise, month 1 employment fails the edit.

In summary, if the monthly employment values for months 1, 2, or 3 pass any of the first five tests, then employment values for that month pass the edit and the sixth test is not performed. If a 6th test is necessary, employment values for months 2 and 3 can pass the edit if they pass the 6th test. This is not so with month 1 employment. If the employment value for month 1 passes (or bypasses) the 6th test, it must also pass the 7th test to pass the edit.

The seven tests consist of the following comparisons

1. Current month to preceding month absolute fluctuation
2. Current month to preceding month percent fluctuation
3. Current month to preceding month t-test (outlier test)
4. Current month to year-ago same month absolute fluctuation
5. Current month to year-ago same month percent fluctuation (seasonality test)
6. Current month to year-ago same month t-test, and
7. Current first month to third month prior quarter (applicable only to month one).

Monthly employment values from the four previous quarters for the same record are not used for comparison if either of the following occurs:

- Employment indicator value of M (missing data), N (zero-filled pending resolution of long-term delinquent reporter), or X (non-numeric employment zero-filled pending further action) in the employment indicator codes, OR
- Status Code of 2 (inactive), 3 (not submitted on the EQUI file for the reference quarter (used in the BLS system only)), or 9 (pending).

For the t-test, the editing of updates to previous quarters may involve using data from **any** of the historical quarters on the file. The most important consideration when determining which quarters' data to use for the t-test is to make sure that 12 months of data are used.

In addition, edits 093 (Employment Without Wages Check) and 095 (Wages/Employment Sum Check) flag records that have large employment and no wages and records where the sum of the employment is equal to the total wages.

Editing Data Changes to Earlier Quarters

To perform the full edit, the system requires that four consecutive quarters of data (consecutive to the quarter being edited) must reside on the state system. If this requirement is not met, the t-test is not performed. The most important consideration when determining which quarters' data the system will use for the t-test is that 12 consecutive months of data are available. The following table summarizes the comparison scheme used in the t-test.

Table 9.2 - Quarters Used for the T-test

Quarters Used for Comparison (X)	Quarter Being Updated and Edited (E)				
	Hist. Qtr.- 1	Hist. Qtr.- 2	Hist. Qtr.- 3	Hist. Qtr.- 4	Hist. Qtr.- 5
Current Qtr.		X	X	X	
Hist. Qtr. - 1	E	X	X	X	X
Hist. Qtr. - 2	X	E	X	X	X
Hist. Qtr. - 3	X	X	E	X	X
Hist. Qtr. - 4	X	X	X	E	X
Hist. Qtr. - 5	X				E

Seasonality Test

The updated employment data (the data being edited) must be compared to data from the same month of the quarter, either four quarters before or four quarters after. This means that the seasonality test cannot be performed on all quarters in the historical file. The seasonality is limited to the current and prior quarters and their respective year ago quarters. (For example, if the current quarter was 2017/1 and an update was made to 2016/3, the t-test would use data from 2016/1, 2016/2, 2016/4, and 2017/1 to edit the updated record.). The following table summarizes the comparison scheme used in the seasonality test.

Table 9.3 - Quarter to Use for the Seasonality Test

Quarters Used for Comparison (X)	Quarter Being Updated and Edited (E) (P-Prior, C-Current)				
	Hist. Qtr.- 1	Hist. Qtr.- 2	Hist. Qtr.- 3	Hist. Qtr.- 4	Hist. Qtr.- 5
Current Qtr.	E-C				
Hist. Qtr.- 1		E-P			
Hist. Qtr.- 2					
Hist. Qtr.- 3					
Hist. Qtr.- 4	X-C				
Hist. Qtr.- 5		X-P			

Reviewing Employment Fluctuations

Monthly Employment problems can be broken down into two situations:

- Within-quarter fluctuations
- Between-quarter fluctuations.

Table 9.4 – Example of a Within-Quarter Employment Fluctuation

1st Quarter	January	February	March
Employment	152	153	49

2nd Quarter	April	May	June
Employment	151	135	145

Table 9.5 - Example of a Between-Quarter Employment Fluctuation

1st Quarter	January	February	March
Employment	152	153	150

2nd Quarter	April	May	June
Employment	16	17	12

In both situations, the analyst would take the following actions:

1. Eliminate the possibility that the data have been entered onto the UI file or other source file incorrectly. UI or source files, and QCR or MWR forms, should be reviewed to see if keypunch errors have occurred. If data were keyed in error, correct the QCEW state system.
2. If the data are correct as reported, then the investigation proceeds to determining a cause for the fluctuation. (The investigation of data fluctuations would include previously-assigned comment codes, reporting patterns, EDI Center contacts, news articles, or other resources discussed in Section 9.9.)
 - a. In the case of a within quarter fluctuation, it may be an event-driven fluctuation. A brief layoff, or a seasonal slowdown may be the cause.
 - b. It may also be an error on the part of the reporter.
3. If a cause cannot be discerned with available resources and an employer contact is initiated,
 - a. Approach the respondent seeking a cause for the fluctuation, although it is very possible that whoever completed the form made an error.
 - b. Seek to verify the reported data if the respondent indicates that there was no event to cause a fluctuation.
 - c. Request verification that the data are correct as reported, if the employer cannot or does not wish to reveal the cause of the employment fluctuation.
 - d. If necessary due to the significance of the respondent and lack of useful information from the respondent, the data may be adjusted with a hand estimate, taking all available employment and wage data into account.

Seasonal Data

For the seasonality test portion of the employment edit, the updated employment data must be compared to data from the same month in the previous year. For updates to the fourth and fifth quarters prior to the current quarter, the comparison will be to the quarter that is four quarters later (to the current quarter or to the quarter immediately preceding it). For the quarter that immediately precedes the current quarter, the comparison will be data for the previous year. The micro edit calculates a seasonal tolerance that helps prevent seasonality from being flagged. However, this component is based on only two observations, the prior year's employment and the current year's employment. Often a seasonal fluctuation will cause the record to be flagged for review. Experience will help an analyst discern seasonality in data.

Example: Each third quarter a strawberry crop is manually harvested and a temporary employment increase occurs in only a few counties. Weather conditions and crop yield causes this seasonal event to fluctuate in size, commencement, and duration. Seasonal data are the hardest to predict and the edit tolerances cannot possibly manage seasonal activity based on the limited number of observations. This event will be flagged for review on the third quarter edit and each year the analyst will bypass these same units with minimal investigation because the same units are likely demonstrating movements similar to the prior third quarter. Another factor that makes seasonal data easier to research is the amount of documentation available. An exceptional strawberry harvest or a crop failure may be noted in the area newspaper. The QCEW program enjoys the advantage of analyzing economic events that are far enough past to be somewhat defined and final yet also be recent enough to be common knowledge.

Wage Record Reporting, Constant Data, and Other Misunderstandings

Wage record reporting is one type of improper employment reporting in which employers simply count the number of people on their wage record report, and include all persons who received any pay during the quarter. Counting checks is another reporting error that can lead to an overestimate of employment if employees receive multiple checks for the reference period. If these mistakes are made consistently, they may never be detected. This condition can be detected when other programs gather similar data and notice inconsistencies between their reports and the QCEW. Conversely, some reporters will not report employees whose wages exceed the taxable limit. When contacting a company, be prepared to answer questions about the Quarterly Contributions Report form and the uses of the data.

Another suspect data situation (sometimes difficult to detect) is the reporting of data as a constant. While some industries are not as prone to turnover as others are, a large reporter should generally show some fluctuation. A small reporter may show a constant level (e.g., 12 employees) and could very likely be correct. However, the following data situation should be investigated:

Table 9.6 - Constant Employment/Varying Wages

Quarter	M1	M2	M3	Total Wages
Year 1/1	1524	1524	1524	11,689,200
Year 1/2	1524	1524	1524	9,562,112
Year 1/3	1524	1524	1524	14,002,619
Year 1/4	1524	1524	1524	17,205,632
Year 2/1	1524	1524	1524	16,199,865

A large reporter that does not experience fluctuations should seem very suspicious to an analyst. Notice that the total wages do fluctuate. While it may be possible to discover the approximate employment for this unit through other sources, which would be helpful information, an employer contact will most likely be needed. The respondent probably has some confusion about how to complete the employment section of the form. The current edits flag these situations for review. A similar situation that would not be flagged would be a large reporter with very small or occasional fluctuations. These situations would only be noticed during the investigation of other flagged elements. In these types of situations, the analyst should pursue the investigation until they are satisfied with all the reported data.

These reporting errors, and several others, are explored at length in Chapter 15 – Recurring Coverage and Reporting Problems.

9.2.2 Edits for Total and Average Wages

The total wage edit (edit code 092 at Level 5 and code 127 at Level 6) consists of a large record edit, two stages, a supplemental edit, and an edit level check. These are preceded by various QCEW Operating Manual December 2004 Editing Micro Data in the States Page 9-14 “condition” checks (a pre-edit, small record bypass check, and a check for newly reported records). Appendix F provides a detailed description with an example.

In the large record stage of the edit, the Total Wages and Average Quarterly Wages (AQW) of the current (edited) and previous quarter are compared to various parameters. In stage one of the edit, the AQW for the current (edited) quarter and previous quarter are compared to another parameter. In stage two, a statistical test is used to compare the current (edited) AQW to the four prior AQWs.

The supplemental edit looks for a significant difference between AQW in the current (edited) and prior quarter, when employment is at a significant level. The edit level check looks for a significant difference between AQW in the current (edited) quarter and previous quarter greater than a calculated parameter.

This edit flags the following types of records:

- Records that fail the large record stage

- Records that fail both stage 1 and stage 2
- Records that fail stage 1 and that do not have enough historical data to perform stage 2 or the supplemental edit.
- Records that fail stage 1, pass stage 2, and fail the supplemental edit.

Previous Quarters

States may sometimes extract or update data *up to four quarters* earlier than the current processing quarter in accordance with the BLS corrections policy). However, only five quarters of historical data will be available on the database. Since all updates should be edited, even four quarters back, the normal micro edits described earlier (see [Section 9.2.1](#)) will not have enough historical data available to perform all the tests. Since fewer tests can be performed, a record has fewer opportunities to pass the edits. This would make updates to the earliest quarters more likely to flag. Therefore, the system does not restrict the data used to edit back quarters to data from quarters preceding the quarter being edited. As with the interquarter employment edit 091/126, the interquarter wage edit 092/127 may also compare the quarter being edited to quarters that are more recent.

Other Wage Edits

In addition, the state and the national office systems perform edits 094 (Wages Without Employment Check) and 095 (Wages/Employment Sum Check) as described in Appendix F. These edits flag records that have large wages and no employment and records where the sum of the employment is equal to the total wages.

Reviewing Wage Fluctuations

Since respondents may face legal penalties for incorrectly reporting wages, wage data are less likely to be incorrect than employment. However, wage data on the tax file may have been estimated for tax purposes or be incorrect due to human error. Wage data may also include large bonuses paid to individuals. While not errors, such changes, without comment codes or narrative to explain the fluctuation, can cause concern for users of the wage information.

Taxable wages and contributions may be derived using available numbers and usually do not require investigation. In the third and fourth quarters, contributions may decline because the maximum taxable level has been reached by a majority of employees. Taxable wages and contributions may be reported incorrectly by employers due to confusion about the maximum taxable level. Overall, wage data changes usually reflect employment data changes. If the level of employees increases, the wages should also increase, usually at a lower rate as new hires are often at a lower wage scale. A decrease in employment should also result in a decrease in wages; however, severance and vacation pay may distort this relationship by causing an increase in wages.

The relationship between monthly employment and the quarterly wages is very elastic. Employment is measured as those who worked or received pay for the pay period that includes the 12th of the month. The key thing to note is **pay period**. Pay periods can be weekly, bi-weekly, and monthly and that timing can exert a lot of influence on the way the data looks when it is submitted to the state. Using the within-quarter data from Table 9.4 (Within Quarter Employment Fluctuation) the following two examples show how pay periods can affect employment and wage data.

Assuming a bi-weekly pay period, suppose a period of low employment in March began February 13 and ended April 12, resulting in a period of low employment spanning nine weeks. Because the employment was normal on the 12th of February and the 13th of April, only March would reflect the low employment level. Compare this event to a period of low employment from March 1 to 15, a two-week period. Both situations would result in the same employment data but with very different wage data.

To further illustrate:

Sample Monthly Activity of a Reporter for the First Quarter

January							February							March						
S	M	T	W	T	F	S	S	M	T	W	T	F	S	S	M	T	W	T	F	S
1	2	3	4	5	6	7				1	2	3	4				1	2	3	4
8	9	10	11	12	13	14	5	6	7	8	9	10	11	5	6	7	8	9	10	11
15	16	17	18	19	20	21	12	13	14	15	16	17	18	12	13	14	15	16	17	18
22	23	24	25	26	27	28	19	20	21	22	23	24	25	19	20	21	22	23	24	25
29	30	31					26	27	28					26	27	28	29	30	31	

Under normal conditions the employer has 100 employees and pays each exactly \$100 dollars per day. The normal Quarterly Contributions Report, QCR, for 1st quarter would state:

<u>M1</u>	<u>M2</u>	<u>M3</u>	<u>Total Wages</u>
100	100	100	\$650,000 (65 work days (Mon-Fri), 100 employees, \$100 per day)

Sample Monthly Activity: Situation 1

A layoff occurs on the 10th of January and lasts until the 6 of February the QCR would state:

<u>M1</u>	<u>M2</u>	<u>M3</u>	<u>Total Wages</u>
100	100	100	\$450,000 (45 work days, 100 employees, \$100 per day)

The four-week layoff would not be reflected in the employment level because the definition of employment includes all employees who worked or received pay during the **pay period that includes the 12th of the month, and we assumed a bi-weekly pay period.** The level of pay is the only indication of an economic event.

A more extreme example would be a layoff that began the 10th of January and ended the 16th of February. The QCR would state:

<u>M1</u>	<u>M2</u>	<u>M3</u>	<u>Total Wages</u>
100	100	100	\$280,000 (28 work days, 100 employees, \$100 per day)

Sample Monthly Activity: Situation 2

Due to a scheduled retooling of production machinery, a temporary partial shutdown during which only ten maintenance employees worked occurs from February 2nd to the 17th. In anticipation of the shutdown, the employer scheduled additional 8-hour shifts of ½ the workforce for January, paying overtime to employees. No new employees were hired. In addition, a \$10,000 bonus was paid to the plant manager. The QCR would state:

<u>M1</u>	<u>M2</u>	<u>M3</u>	<u>Total Wages</u>
100	10	100	\$708,000 (52 work days, 100 employees, \$100 per day + 22 work days, 50 employees, \$150 per day + manager's bonus + 13 work days, 10 employees, \$100 per day)

As illustrated earlier, the within quarter employment fluctuation would look very much like a keypunch error. The point this example should illustrate is that wages may not follow employment trends, but the normal behavior of employment rising and wages following or employment falling and wages decreasing is more likely to be observed.

Other Simple Observations about Employment and Wage Patterns

New hires are usually paid less and are the first to be let go.

This is why employment's decrease can be more severe than the wages.

New employees may start employment on any day of the quarter.

If an employee was hired on the last day of the pay period including the 12th, the employee would be included in the employment total for that month and all wages earned until the end of the quarter would be included in Total Wages. While a single employee would not make much difference, this kind of situation can have a cumulative effect on the data.

Bonuses are a very common occurrence in all industries.

These events may or may not follow a seasonal pattern, and may or may not recur. They are very disruptive of data patterns and can be difficult to research. A review of the wage record of a reporter, if the research unit has access to this information, can help determine if bonuses were

paid. Wage information is usually considered privileged and the employer may not wish to discuss it over the telephone. It is important to remember when contacting a company that there is no way for them to know that you are actually a state employee performing statistical verification and not another party using deception to gather personal information.

9.3 Address Editing: At Least One Clean Address

Problems in Non-Quarterly Data

Non-quarterly data problems are less complex in nature, but may have a direct and immediate impact on in-house data users. Consequently, these data users are more likely to ask questions and offer information. Unfortunately, the contact person for one program may not be supplying the same information as the contact for the QCEW program. For this reason, some solutions to non-quarterly data problems may not be usable or may not even be valid.

During the micro edit, the analyst will find situations where units have been incorrectly coded or addressed. While the correction of industry codes follow specific guidelines (see Chapter 2 - Assigning and Updating the Classification Codes), address corrections should be made immediately.

Address Edits (070)

The edit reviews up to three address blocks per record. These address blocks are field specific on the micro and EQUI files.

1. Physical Location Address
2. Mailing/Other Address
3. UI Address

The edit requires only one to be usable. Each address field is examined separately, then blocked together as an individual address, and then compared to determine if any meets all editing requirements. An address block is defined by the following six components:

- Street Address Line - 1,
- Street Address Line - 2,
- City, State, Zip Code, and Zip Code Extension.

If at least one address block passes the edits, then all flags are counted but only a limited number of fields will be listed for review (only where appropriate). If none of the address blocks pass the edits, then the system assigns I-error 070 and lists all three addresses. This allows all address information to be available for review so that the address problems can be resolved for that record. The address data elements do not affect macro edits or the various uses of economic data.

All of the address fields are edited separately, and fields, other than zip code fields, that contain all zeroes are blanked out. (The address zip code and the address zip code extension are blanked out only if all other address fields are blank.) For the **record** to pass the address block edit, just one **address block** has to pass the edits. An address block will pass the edit only if all of the **fields** in the address block pass the edit. This will ensure at least one usable address. Information about addresses that do not pass the edits will be given in the counts/listings. For multi-unit accounts, the master address should be copied to subunits that do not have useable addresses.

Federal addresses are not edited, therefore the system first determines if the ownership is Federal government (Ownership code of 1).

Large Record Without Usable PLA Check (Edit 088)

To pass this edit, records must contain a full Physical Location address that can be geocoded. To test for usability and the ability to geocode the Physical Location Address, the system examines each address field separately, then blocks the fields together as an individual address, and then compares the blocked address to determine if it meets all editing requirements.

This edit will flag a record with significant employment if either of the following conditions is met.

- All of the PLA fields are blank or missing.
- The record's PLA is flagged for any other PLA edit (edit 102, 103, 104, or 114).

Further details on edit 088 can be found in Appendix F.

9.4 Multi-Establishment Editing

Employers with multiple locations should report data using the Multiple Worksite Report (MWR), or report their MWR data centrally to the EDI Center (their MWR data are transmitted quarterly to the state by the EDI Center) or quarterly via MWR Web. The Level 8 multi-establishment edits screen reporters who have multiple establishments (multiple reporting units with the same UI Account Number). The system first identifies the reporter as a multi-establishment via the Multi Establishment Employer Indicator (MEEI) Code. MWR reporting units appear in the micro edits in the same manner as individual reporters, and are generally edited in the same manner in the other edit levels.

The MWR data from the current quarter can be easily compared with the data from the previous quarter. In this manner, sites that have “disappeared” or have relocated can be identified. The discontinued locations may have been sold to another employer (another UI account), who either does not break out data in the same manner or may be reporting them incorrectly. Once a multi-establishment account is identified, there arises the need to differentiate each individual unit. To accomplish this, each individual unit carries a unique identifier, the Reporting Unit Number

(RUN). Several of the multi-establishment edits use RUNs in combination with the MEEI Code to verify that multi-unit accounts are properly configured: the account should contain one master record representing the account as a whole, and at least two subunit (worksites) records.

Multi Establishment Employer Indicator

The MEEI is a required, quarterly code that distinguishes between records for single units, multi-unit master records, and subunits of a multi-establishment employer. State QCEW staff assigns this code. There is no state default value.

The MEEI code has six valid values:

- 1 = Single establishment unit (not a multi)
- 2 = Multi-unit master record
- 3 = Subunit establishment level record for a multi-unit employer
- 4 = Multi-establishment employer reporting as a single unit due to unavailability of data, including refusals
- 5 = A subunit record on the state's file that actually represents a combination of two or more establishments. Finer level breakouts not yet available.
- 6 = Known multi-establishment employer reporting as a single unit and not solicited for disaggregation because of small employment (< 10) in all secondary establishments combined

Reporting Unit Number

The Reporting Unit Number (RUN) is a 5-digit number used to uniquely distinguish worksites of a multi-unit account, and is a key (identifying) field for every reporting unit. The RUN is required but non-quarterly. State staff assigns the RUN for new worksites with multi-unit accounts. Single and master records are assigned zeros (00000) as part of the extract process. Most state UI tax files do not include a reporting unit number field, as defined by BLS. In these cases, the Reporting Unit Number should be zero filled when extracting single and master accounts from the tax files.

The valid RUN values for single and master units are 00000. Subunits (worksites) must have RUN values greater than 00000. RUNs for subunits of the same UI Number must be assigned sequentially and **not reused**. When a multi-unit account is set up for the first time, the first subunit must have a RUN of 00001, and the number for each additional subunit must increase by 1. For example, a UI account with three subunits will have them numbered 00001, 00002, and 00003. Gaps in the numbering system may occur over time due to closed or sold units. The Level 8 edits require the RUN of each record to be consistent with the MEEI. Records with MEEI of 1 (single), 2 (master), 4, (multi reporting as single), or 6 (multi not solicited) should have a Reporting Unit Number of 00000. Records with MEEI of 3 (subunit) or 5 (combined subunit) should have a Reporting Unit Number greater than 00000.

If an “orphan” occurs (where a multi-establishment account or family terminates all units but one, leaving a single, surviving worksite), use RUN 00000 for the remaining unit. Assign the

correct MEEI Code (typically MEEI 1). Since the account should already have a master record whose RUN is 00000, the record for the orphaned subunit (whose RUN is greater than 00000) should be inactivated, and its data should be assigned to the RUN 00000 record for the current quarter. The MEEI code of the RUN 00000 record should be changed from 2 to 1 in the current quarter. To assist in longitudinal record linkage, the RUN 00000 record (which now represents the surviving worksite) should have a predecessor UI Number and RUN pointing to the inactivated record that used to carry its data. In addition, the inactivated orphan may be assigned a successor UI Number and RUN pointing to the RUN 00000 record.

Consistent EINs and Ownership Codes

The Federal Employer Identification Number (EIN) is assigned by the IRS to each employer (corresponding to each UI account). All units in the account should therefore carry the same EIN. The Ownership Code indicates the legal proprietorship of the enterprise (the UI account), and therefore all units in the account must carry the same Ownership Code. These relationships are enforced by Level 8 I-error edits.

Indian Tribal Councils

For those accounts that are recognized Indian Tribal Councils, all units in the account should have a Special Indicator value of T. This relationship is also enforced by Level 8 I-error edits.

Additivity

In multi-unit accounts, the master record (with MEEI 2 and RUN 00000) corresponds to the Quarterly Contribution Report (QCR) – it represents the UI account as a whole, as the employer reports data to the state UI program. The subunits, taken as a whole, represent the UI account as the employer reports to the QCEW program on the MWR or to the EDI Center or via MWR Web. The economic data on the QCR should equal the economic data on the MWR, and the combined data of the subunits should equal the data on the master record. The Additivity/Balance Edits (171-176) of Level 8 ensure this relationship. The combined data of the subunits for employment, total wages, taxable wages, and contributions should equal the master record data.

When the data are out of balance by more than a small tolerance, the UI account will fail the additivity edits. Subunits (worksites) may be missing from the MWR or may be duplicated. There may be keypunch errors on the MWR or the QCR form. When additivity flags occur, take appropriate measures (similar to those discussed in Section 9.2.1 for reviewing employment fluctuations), such as the following:

- Verify keypunching.
- Review resources (see Section 9.9).
- Contact the EDI Center, if they provided the data.

- Contact the employer.

9.5 Using Wage Records in Editing

Wage record edits should be run in the state and BLS if the data are accessible. They should be run either with the other edits, on a lagged basis when most of the information is available, or periodically to capture potential reporting problems. These edits help to identify reporting problems that are frequently missed by other edits when the data normally do not fluctuate from month to month or over time.

Wage records are individual records of employees who have worked for an employer during a business quarter. Employers are required by law to report wage records to the respective state UI program for all UI-covered employees. Because wage records account for all employees paid during a business quarter, they may or may not reflect the number of employees an employer has during the pay period that includes the 12th of the month. Due to the potential of wage records to exceed the employment during that pay period, they are only used for hand imputations and for comparison of data.

Wage records may be used to hand impute data for the following items:

- First Month Employment
- Second Month Employment
- Third Month Employment
- Total Wages

All seven wage record edits issue W-flags. These Level 9 edits are fully described in Appendix F. Each wage record edit will be bypassed if any of these conditions are met:

- The wage record count or wage record wage is zero or invalid
- MEEI = 3 or 5 (the record is a subunit)
- Type of Coverage = 1, 3, 8, or 9 (the account is reimbursable or is not UI covered)
- Ownership = 1 (Federal)
- The wage records are not available.

Table 9.7 - Wage Record Edits

Edit Code	Edit Message
191	Questionable Wage Record Count
192	Questionable Wage Record Wages
193	First Month EMPL > Wage Record Count
194	Second Month EMPL > Wage Record Count
195	Third Month EMPL > Wage Record Count
196	All Months Employment = Wage Record Count
197	Total Wages Vary From Wage Records

9.6 Using BLS Comment Codes

The QCEW standard comment codes and their meanings are fully listed in Appendix I. Assigning QCEW comment codes simplifies the review of edit listings by the state and BLS. Comment codes should explain fluctuations or changes in the data that cause current quarter records to be flagged as questionable. After the state EQUI files are submitted to BLS, BLS provides the comment codes to the Bureau of Economic Analysis (BEA), along with QCEW macro data, to assist in the preparation of BEA's personal income estimates. Comment codes can also be an important reference by BLS survey users seeking to understand a data fluctuation or abnormality.

The standard BLS QCEW comment codes can only be applied to micro records. Assign the comment code(s) which best explains the reason or cause of the fluctuation/change in the specific data element(s) or record. Comment codes should not be used in lieu of addressing issues regarding the proper and accurate reporting of data.

States have the option of using up to three standard comment codes on a micro record. A 57-position narrative comment field is also available for each micro record for use when the standard comment codes are not applicable or sufficient. A narrative can be used to provide specific supporting or supplemental information about flagged reporting units that have significant employment, or data changes that are especially significant or unusual. At least one numerical comment code should accompany a narrative comment. A numerical comment of 99 should be used along with the narrative if no other numerical codes are assigned.

Comment codes are grouped and based on the data elements most affected by the change. States should, however, use the comment code(s) which best explains the data fluctuation regardless of its grouping. Comment codes are grouped according to the following list:

- Employment shifts
- Pay shifts
- Hours, time and vacation issues
- External factors
- Secondary effects
- Environmental legislation
- Defense-related codes
- Temporary codes
- State specific CES codes
- Tax and coverage changes
- Coding and classification changes
- Reporting issues
- Data verification

Using standard comment codes to explain reporting issues (comment codes 82-93) does not preclude the proper coding and processing of accurately reported data. Comment codes are

helpful in clarifying or highlighting particular reporting issue changes (e.g., mergers, predecessor/successor transactions, or changes in the basis of reporting) for those accessing the data or researching the relationship between worksites. Appendix I includes a number of comment codes relating to business and reporting issues. Comment code 98, Data Verified/Accepted by EDIC, must not be assigned by states. This code is reserved for use by the EDI Center, for use on reporting units of centrally collected employers. When the EDI Center has assigned comment code 98, States that properly load the MWR files provided by the EDI Center will have this code on their state system, and the EQUI file will provide this code to the national office.

BLS strongly recommends that states send supplemental narrative material to their regional office if significant data shifts affect numerous records. For example, state unemployment insurance coverage changes affecting the definition of covered wages or employees can result in notable data shifts affecting large numbers of macro cells. A specific example of this would be a change to exclude from wages employer contributions to certain types of pension plans, which had previously been considered covered wages, resulting in a broad decrease in wage levels. A change in unemployment insurance coverage or a new interpretation of existing laws for classes of employees such as parochial school employees, poll workers, or the status of religious institution workers, are also examples when such documentation would be beneficial.

Comment Code Examples

Some examples of comment code usage are listed below. This is not a complete and exhaustive list.

<u>Situation</u>	<u>Comment Code</u>
If a new unit that did not exist before begins operations, code the unit...	85
If a multi-establishment account sells or closes all but one of its sub-units (the master record becomes a single), code the single...	00
If a single or multi reporter begins reporting data after an extensive period of imputed, prorated or inaccurate data, and the employment and wages are noticeably different, code the single or master and sub-units	48
If a unit that previously reported in a different state, begins newly reporting in state, code the unit...	17
If a record that previously reported aggregated data begins reporting sub-unit or disaggregated data, AND	
a. if disaggregation causes a change in industry code or county code, code the master record...	90

<u>Situation</u>	<u>Comment Code</u>
<ul style="list-style-type: none"> b. code the disaggregated sub-units that do not experience a change in the industry or county code... 	90
<ul style="list-style-type: none"> c. code the disaggregated sub-units that will change industry or county codes in the first quarter... 	90
<p>If a new unit of a multi-establishment reporter</p>	
<ul style="list-style-type: none"> a. begins operations that did not exist before AND 	
<ul style="list-style-type: none"> b. has not previously reported its employment and wages data as part of another unit of the multi, then code the new unit... 	85
<p>If a unit of a multi-establishment reporter</p>	
<ul style="list-style-type: none"> a. begins reporting separately AND 	
<ul style="list-style-type: none"> b. previously reported its employment and wages data as part of another unit of the multi, then code the unit... 	90
<p>(Separately reported units should not experience any non-economic code changes as a result of this reporting change until first quarter.)</p>	
<p>If a unit no longer provides disaggregated sub-unit data,</p>	
<ul style="list-style-type: none"> a. AND if aggregation or collapse of the multi-establishment breakout causes a change in industry code or county code for any sub-unit portion of the multi-establishment, then code the sub-unit record (if available)... 	91
<ul style="list-style-type: none"> b. code the collapsed MEEI 4 record... (Multis should not be collapsed outside of the first quarter if data will change industry or county codes. Data should be prorated until first quarter.) 	91
<p>If a single unit is bought by a new owner who did not previously operate in the state, code the new unit...</p>	93

<u>Situation</u>	<u>Comment Code</u>
If a single unit is bought by a new owner who already had existing operations in the state,	
a. code the master record of the purchasing account (successor) as an establishment merger...	93, 89
b. code the selling account (predecessor)...	93
c. code each sub-unit (only if employment level for the sum of the secondary subunits is 10 or more)...	93
i. set up a multi-establishment breakout effective with the quarter of the purchase if the purchasing account (successor) was previously a single unit.	
OR	
ii. add the purchased unit to the multiple worksite report (MWR) effective with the quarter of the purchase, if the purchasing account (successor) was previously a multi-establishment reporter.	
(Purchased units should not experience any noneconomic code changes as a result of the purchase until first quarter.)	
If a new owner who did not previously operate in the state purchases a multi-establishment account, code the master and each sub-unit of the successor and predecessor...	
(The successor should continue to report the breakout and the purchased multi-establishment account should not experience any noneconomic code changes as a result of the purchase.)	93
If a new owner who already had existing operations in the state purchases a multi-establishment account, code the purchasing account (successor) as an establishment merger...	
	93, 89
Code each sub-unit and the successor's pre-existing unit (that should now be set up as a sub-unit)...	93
i. Set up a multi-establishment breakout effective with the quarter of the purchase if the purchasing account (successor) was previously a single unit.	

<u>Situation</u>	<u>Comment Code</u>
OR	
ii. Add the purchased sub-units to the successor's MWR effective with the quarter of the purchase if the purchasing account (successor) was previously a multi-establishment reporter.	
(The sub-units previously owned by the purchaser should not be assigned reporting issue comment codes relating to the merger. Purchased units should not experience any noneconomic code changes as a result of the purchase.)	
If employment changes within an <u>individual</u> unit or sub-unit resulting from an internal reorganization,	
a. code a resulting increases in employment...	13
b. code a resulting decrease in employment...	12
If a multi-establishment account sells one or more (but not all) sub-units, code the master record of the predecessor...	
a. code the sold sub-unit(s) of the predecessor...	92
b. code the purchased sub-unit(s) [can be either a newly set up sub-unit(s) or a predecessor/successor transaction]...	93
(The sold sub-units should not experience any noneconomic code changes as a result of the sale.)	
If a single unit or a sub-unit sells a portion of its operations or business to a new account,	
a. code the predecessor unit (depending on the circumstances involved in the reporting change) as a dissolution...	88, 92
b. code the purchasing unit as a merger...	89, 92
c. code new sub-units as breakouts...	93
If an account shifts employment from one unit to another within the same account,	

<u>Situation</u>	<u>Comment Code</u>
a. AND if the sub-unit(s) involved existed before, and there was no significant change in scope, code the respective intra-account (firm) transfers as...	15
b. if a sub-unit is eliminated as a result of the intra-account (firm) transfer, code both the unit absorbing the employment and/or operations and the eliminated unit(s)...	15
c. if sub-unit(s) are added as a result of the intra-account (firm) transfer, code both the new unit(s) and the unit(s) losing employment as an intra-account (firm) transfer...	15
If an employer eliminates a large percentage of jobs, laying off many people while downsizing operations, code the record...	12
If most employees of a unit go on strike against the employer, code the record as a strike...	08
If most employees of a unit go on strike and the employer hires replacement workers at lower pay, code the record as having an increased percentage of lower-paid workers...	08, 22
If an employer moves an established business into the state from another state, code the record as moved into state...	17
If an employer moves an established business into the state from another country, code the record as new business...	85
If an employer lays off employees	
a. because it is the end of a seasonal operation, code the record as a seasonal decrease...	02
b. while retooling the assembly line, code the record as a conversion or retooling...	10
c. during a shutdown while remodeling, code the record as conversion or remodeling...	10
d. when the operations failed a health and safety inspection, code the record as a temporary shutdown...	09

<u>Situation</u>	<u>Comment Code</u>
c. because of less demand for goods or services, code the record as less business...	04
f. without notice but the impact of the layoff can be verified by reports in the local news media, even when no reason is given, code the record as a layoff...	07
If an employer lays off the employees as the firm enters bankruptcy, code the record as bankrupt...	12
If an employer resumes operations after being inactivated or coded out of business and the employer is reassigned the old account, code the record as reactivated...	87
If an employer ceases to report the majority of the employment, turning over that responsibility to an employee leasing firm/Professional Employer Organization (PEO), code the original firm and the new unit as switched to employee leasing...	83
If an increase in Total Wages for an account is reflected in data on the wage records, code the record as showing a general pay increase...	97
If employment and wages increase significantly for units of an employer in a volatile industry, and that employer reports through the EDI Center, the EDI Center will assign the code... (Note: ONLY the EDI Center may assign comment code 98.)	98

9.7 Setting the Parameters

Many of the micro and macro level specifications include parameters (parms) and tolerances. To determine reasonableness, most data elements are compared to other data elements or to the same data element over time. Tolerances are used to allow a reasonable amount of leeway between the "expected" value for a data element and the value actually reported or imputed. Data elements that have a limited, known set of values (e.g., Ownership Code) are edited to check for exact matches. Other data elements, such as Trade Name, are alpha-numeric and can contain any value. Parameters are also included in the edits to ensure efficient use of state resources without a negative impact on data quality.

State Integrated Edit vs. the national office Integrated Edit

All edits run by the national office are expected to have been run by states. The editing of summed micro data is based on a number of constants and tolerances. State systems allow users to tighten these tolerances beyond the national office default levels to suit the needs of the state. EQUI files sent to the national office always include a header record that gives the editing parameter and tolerance values used by the state. The rate used to compute the amount of employee contributions collected is also provided as a parameter on the EQUI header record. Although states can modify their parameters and tolerances each quarter, only the parameters and tolerances used for their most recent processing are submitted on the header record. The state systems only maintain the most current parameters, and they are applied to all data processed until they are changed. Any revisions to the parameters and tolerances should continue to respect the need for data quality.

The national office parameters and tolerances are never tighter than those of the state, unless the state has set theirs above acceptable levels (above the default values shown in Appendix H). The national office parameters are higher than or equal to state default values, since this allows the national office edit listings (described in Section 13.2.3) to identify the most serious data conditions (conditions most in need of correction or explanation).

Recommendations

States should consider these points when setting their editing parameters and tolerances:

1. Set edit parameters based on data quality standards.

The distribution of work, the number of staff to review the material, and the tools available to facilitate the review all impact the editing results. Setting parameters/tolerances to smaller values may cause more records to flag than can be effectively reviewed; this can lead to significant errors being overlooked.

2. Set employment and wage edit parameters to identify potential problems for micro records with significant employment and wage levels. In addition, set these edits to capture problems in the published macro levels.

Micro level data are frequently used for sampling and solicitation by other BLS programs. These data are also used to compare reporting practices between CES respondents and the QCR or MWR reports to resolve reporting problems. Macro level data are published and released by BLS to various users at levels as detailed as industry, county, ownership, and occasionally size class.

3. Prioritize review of critical non-quarterly data based on the needs of data users.

Some non-quarterly fields are of greater importance than others. For instance if one useable address already exists on most records but the identification of EINs is below acceptable

levels, it is more important to strive for better EIN information than to seek out supplemental address information. By setting small parameter/tolerance values for EIN edits, the states can focus on this important data element. See Section 13.3.2 for more detail on edit priorities.

9.8 Determining the Research Needed

The goal of editing QCEW is to produce the best quality data in the relatively short time allowed. The record flags produced by the edits help analysts prioritize data for investigation. Analysts should verify the data in the flagged records as correct or replace with corrected data. Due to time constraints, analysts should prioritize records flagged with lower edit codes. Editing individual records can become time consuming, so individual analysts should be mindful of their timeframe when making the decision to terminate or continue their investigation into individual records. In short, analysts should organize their work to get “the most bang for their buck”.

The first extract will usually include the most records with incorrect data. The optimum goal of the review is to investigate each flagged record and either verify the data as correct or to replace it with correct data. Due to time constraints, this level of investigation may not be achievable. Analysts must apportion their time to the records that are most significant and most likely incorrect. As the analyst progresses through the edit, they will constantly have to reassess progress and target completion date. Investigation of records may proceed faster or slower than initially expected and the analyst will adjust the effort expended per record accordingly. The decision to terminate or continue investigation is necessary because of the time frame within which the analyst must work. Analysts have to maximize the effect of their review by using judgment in deciding which records to investigate and to what degree this investigation progresses.

Suspect Data Situations: Missing Data or Missing Reports

The first extract will contain the most records with missing data items or missing reports. The majority of these will be received and processed sometime within the quarter or additional data will be received as a result of the mailout of missing data notices. Machine-generated estimates of delinquent accounts may be made at a later stage of QCEW processing as discussed in Chapter 8. The analyst must review these machine estimates and determine whether to use the machine estimate or replace with a hand (manual) estimate. The system will not estimate missing data indefinitely, and significant reporters who are missing for extended periods, but still in operation, may have to be manually estimated until a report is received or contact is made with the company.

Estimates should always be replaced with employer-supplied data when it becomes available. This does not lessen the importance of editing the estimated data because the units may be undergoing transition, or the employers may not understand how to complete the quarterly

report. To put it simply, a report missing data obviously has problems and identifying which reports have problems is the purpose of the edit.

More Suspect Data Situations: Data do not Correspond with Prior Reports

If the current quarter's data are incorrect, it can be corrected during the quarter. However, if the prior quarter's data are incorrect, then back quarters must be addressed. Significant back quarter corrections will impact other programs, especially CES. These users must be made aware of these back quarter corrections.

Although it should be the goal of each state to deliver the most accurate data possible on the quarterly deliverable EQUI, the need to make corrections to back quarter data will always exist to some extent given the volume of data records being processed. Generally there are two causes for back quarter corrections:

- The record did not flag on the past quarter's edit but did flag on the current quarter's edit. The current quarter's data are actually correct, but it is discovered that the prior quarter's data are not.
- The record may have been flagged for review on the prior quarter's edit and may have resulted in an employer contact. The employer's response may have not been received until after that quarter's cleanup date.

Some amounts and types of back quarter corrections are a normal part of the quarterly edit and do not negatively reflect on the research efforts of the analyst.

9.9 Resources for Researching Suspect Data

Each state has its own methods and resources for researching data events. Variations in UI laws, computer systems, communications between programs and agencies, and even the physical characteristics of the state are reflected in these review procedures. There are some common resources and methods. This chapter can serve to guide the state analyst by describing, in general terms, the procedures to follow while investigating suspect data.

Examples of resources and their format:

Quarterly Contributions Report	Electronic or paper
Multiple Worksite Report	Electronic or paper
Annual Refiling Survey	Electronic
QCEW state system	Electronic record of establishment history

UI database	The state agency's repository of UI-related data
Tax documents and systems	Forms used to create new accounts, transfer accounts, or change existing accounts (part sales, additional business etc.); online systems
Wage Record Database	The state agency's repository of wage record data
EDI Center	Email, for centrally collected employers
Internet	Search engines by name, product, or service (See Appendix T – Useful Links and References)
Telephone contact	Employer or local Unemployment Insurance office
Other research programs	Be aware of special projects or program developments that may supply data or insight into industries
Newspaper articles, Company websites, Trade Association websites	Internet or paper

With experience, the analyst will develop a methodical routine for researching different data situations. The first step is to verify the data from the source document and the final step should be contacting the employer directly.

Other BLS/State Programs

The employer's contact person for one program may not be supplying the same information as the contact person for the QCEW program.

This can create conflict between QCEW and other programs. Some conflicts between programs are due to differences in program definitions and concepts. Analysts should be aware of these differences and accommodate them to the best of their ability while adhering to QCEW program concepts. Direct conflict between employer-supplied information when there is no conflict in program definitions should be investigated and resolved in the state agency. This requires cooperation between program analysts and a willingness to accept information from other programs.

Employer Contact

This is by far the most difficult part of the analyst's job. Although a phone number and the name of a contact person are available, that person may not be able to answer your questions. It is not unusual to talk to several different people before a data question can be resolved. This can be very frustrating and time-consuming. When contacting an employer, the analyst must remember that they are representing not just their agency, but the entire state government. If an analyst encounters resistance to their inquiries, the fault could lie with an unfavorable impression formed during an earlier contact – an impression that can be overcome or improved by acting in a courteous and professional manner. Although an occasional negative experience can be expected, it is more normal that the employer will answer your questions, and will have a positive opinion of the experience.

9.10 Resolution of Suspect Records

The investigation of suspect data will be an ongoing process from the first micro edit until the submission of the quarterly file. When making a correction, it is important to only replace suspect reported data with data from a verifiable source. Again, the analyst's judgment plays a large part in this decision. These decisions may have to be reviewed throughout the edit. To facilitate this effort, good documentation procedures should be developed.

Documentation

During the edit process, meticulous care must be given to documenting the research performed on a file and to the corrections made on the file. This will save time when you have to answer inquiries from other analysts and in working future quarters. The documentation may consist of only the name of a company or contact, date, address, or brief remarks but should be made in a consistent, legible manner so that a data situation can be explained without too much personal recall. There is not enough time to document every detail of a data event the analyst researches, so document enough to backtrack the editing steps which will support the data. Using comment codes as a shorthand facilitates this well.

Additional documentation may be recorded in the Narrative Comment field, where the information would be useful to BLS reviewers or other data users. The standard state systems also include note fields, which are not copied to the EQUI file. Use a note field for helpful information that does not address data issues (for example, specific information about the employer contact).

An example using the previous data:

UI 123456789 Cty 123 Own 5 NAICS 316210

<u>M1</u>	<u>M2</u>	<u>M3</u>	<u>Total Wages</u>	<u>Taxable Wages</u>	<u>Contribution</u>
100	10	100	\$687,500	\$450,000	\$25,000

Called 05/10, Talked to Rita Book, Chf Acct (909)999-9999, OT in Jan, Feb Layoff for retooling, 1 employee Bonus = \$10,000

or 05/10, Rita Book, Chf Acct (909)999-9999 cc 27-M1, cc 10-M2, & cc 31-10k

This notation would be adequate for an event of normal significance. For larger or more unusual events, more detail should be included. In the example, comment codes were preceded by a “cc” to distinguish them from other numerical details.

Other examples of annotation for normal data events:

Closed 7/10

Business was closed on July 10th.

or **cc 86 7/10**

Prior qtr data in error, rptd cor.

Data reported incorrectly for prior quarters; it is now being reported correctly. Back quarter corrections may or may not be available.

OOB Q3

Unit was Out of Business in the 3rd Quarter.

or **cc 86 Q3**

Correction:

Notation of a correction and source.

Emp M1 and T.Wages

Emp cont: Ida Nough 6/8

cc 31, 7/10

Total wages verified, including substantially higher bonuses paid.

Higher than normal bonuses paid

cc 03, 7/12

Employment increase due to more business and added another shift.

Added another

shift of workers

cc 99, 7/15

Employment decrease due to privatizing (contracting out) half of employment operations (mailroom and billing).

Privatizing parts

of govt operations

While it is up to the analyst to be able to decipher their own notes, some effort should be made so that all analysts are able to retrace the others' steps. Common methods would also aid in training new analysts.

Closing a File

Normally the investigation of records results in either a correction or documentation of anomalous data. At the time of the submittal of the quarterly EQUI file, it is expected that all data are clean – corrected or updated with comments. Remaining questionable data will be identified by the BLS edit and are to be corrected or commented on during the cleanup period. However, it is possible that some questions are not resolved by that time. An accurate correction may not be possible until the following quarter, or later. This can be frustrating to an analyst who wishes to “finish” a quarter and submit a “clean” file. The analyst must understand that they are seeking to achieve the highest level of quality in the allotted time using every means available.

9.11 Improving Data Quality

Although the edit review process will continuously undergo refinement and improvement, it will always require the analyst's judgment. Throughout the micro edit, the analyst will use his/her own discretion, based on past experience in reviewing the industry or individual account, to decide if the suspect record warrants further investigation or can be bypassed.

These are examples of the kinds of familiarity an analyst gains through editing:

- Seasonal events such as harvests, tourism, holidays, hunting seasons, and layoffs
- Industry employment and wage patterns
- Industry locations
- General growth or decline of industries
- Emerging industries
- Related industries, and the nature of their relationship
- Opening or closings of specific sites
- Past telephone contacts
- Experiences with other reporters in the same industry
- General economic conditions

By working the quarterly files, in conjunction with the annual refiling, an analyst is exposed to nearly every facet of the state's economy. With each quarter's edit, the analyst will accumulate background knowledge that contributes greatly to the overall quality of the data.

Chapter 10 – Macro File and the Integrated Edit

The standard state systems (EXPO-202 and WIN-202) and the national office system all generate macro files from their micro data. The integrated edit screens basic macro file cells for reasonable levels of aggregated economic data, while applying similar editing to the micro records that make up the cells. Since the macro file depends on the micro data, the integrated edit promotes the resolution of questionable data encountered on the macro records by associating the flagged macro data with specific micro records. Macro records cannot be corrected independently but must be corrected by making adjustments to the micro records. Where the suspect data are verified as accurate, they should be explained by assigning comment codes (and sometimes narrative comments) to applicable micro records.

The states also generate macro data summary files and send copies to their regional office. The states, the national office, and the regional offices review these data files to find questionable large data fluctuations at the statewide level by various industry aggregates for all ownership codes.

----- Contents of Chapter 10 -----

- 10.1 Aggregating Reporting Units by County, Ownership, and Industry Codes
- 10.2 Macro Level of the Integrated Edit
- 10.3 Code Changes and Macro Data
 - 10.3.1 Code Change Integration for Noneconomic Code Changes
 - 10.3.2 Other Code Changes
- 10.4 Macro Data Review

10.1 Aggregating Reporting Units by County, Ownership, and Industry Codes

Micro data in the QCEW program are reported at the establishment level. Each record – each reporting unit – on the state micro database typically represents one establishment. Reporting Unit Numbers (RUNs) are assigned to each micro record, and RUNs must be unique within each Unemployment Insurance (UI) account. Every record on a state's system must have a unique UI Account Number/RUN combination because these two fields in combination are its identifying or "key" fields.

The micro data are aggregated to higher levels at several points in the quarterly processing cycle. The basic aggregation used in the QCEW program is the county-ownership-six digit NAICS cell. One "macro" record is created for each basic cell, showing the combined employment and wage data of all reporting units (all micro records) that have the same unique combination of county code, ownership code, and 6-digit industry code. These three codes in combination are the identifying or key fields of the macro record.

Each quarter, the micro data elements that are aggregated on the macro file in the integrated edit include:

- Number of Establishments
- First Month Employment
- Second Month Employment
- Third Month Employment
- Total Quarterly Wages

At least eight quarters of macro data are available. Information about macro files and processing in the QCEW processing systems appears in the user documentation for these systems.

Additional data elements may be aggregated for other purposes. Higher levels of aggregation are generated for publication (see Appendix U).

The state systems and the national office system generate macro files based on the NAICS industry code. Information about NAICS coding appears in Section 2.1.5.

Some micro records are excluded from all aggregations, so they are never represented on macro records. The following exclusions apply:

- Master (MEEI 2) records are excluded because they do not represent individual establishments. Instead, master records represent the combined state total of all worksites (establishments) in a multi-establishment UI account. The economic data of a master record duplicates the combined data of its subunit (worksite) records. The data from the subunits (and not the master) are used on the macro file because the subunit records carry the accurate county and industry codes for each establishment.

- Records that are inactive or pending (records with Status Code 2, 3, or 9) are also excluded from the macro file. Establishments that are inactive should not contain economic data since they are not operating in the reference quarter. Establishments in pending status are generally set up in advance to provide greater detail of economic data in a future quarter. The inclusion of inactive or pending records might duplicate the employment and wage data on active records. (See appendix B for Status code definitions.)

In the national office system, micro records are excluded if the Type of Coverage Code is 8 (not UI- or UCFE-covered). Additional exclusions include records with County, Ownership, or NAICS fields with all zeroes or non-numeric data.

States send only micro data to the national office on the Enhanced Quarterly Unemployment Insurance (EQUI) files. In both the national office and the states, the macro data are generated from the micro data. No changes or corrections are made to macro data directly. Instead, all corrections are made at the micro level, after which the macro data can be re-aggregated when needed.

As Section 10.4 describes, the states also generate macro data summary files at several points in the quarterly processing cycle and send them via e-mail to their regional office. These files are generated at higher levels of aggregation than the macro cells described above (the macro file used by the integrated edit). The macro data summary files are used for data review purposes only and are not used for publication or provided to data users.

10.2 Macro Level of the Integrated Edit

The integrated edit screens basic cell macro data and micro data in combination, applying similar editing at both levels. This approach is intended to flag suspect data that are significant at the macro level but that can be identified and corrected at the micro level. The macro edits are not applied above the basic macro cell level. For example, it is possible to create Metropolitan Statistical Area and statewide macro data cells from the micro data, but these cells are neither created nor edited. Macro cells above the six-digit NAICS level are also not generated for the integrated edits. This practice saves computer time by not running higher level macro data through edits. However, higher level macro data are shown on the edit output and should guide a top down review and prioritization of edit flags. A top down review of macro data is essential for state and BLS publications. Flagged micro records appear on EQUI edit output Tables 9A and 13B. Aid in prioritization can be found in the discussion of Table 2A (state totals) in Section 13.2.2.

The following are the macro edits. Appendix F (Edit Conditions and Formulas) explains in detail how they operate.

Level 5 -- Significant Employment & Wage Macro Edits

Edit Code	Edit Message
089-W	WIN-202 Only: Month 1 Employment Change Greatly Exceeds Test Parameters
090-W	WIN-202 Only: Month 2 Employment Change Greatly Exceeds Test Parameters
091-W	EXPO & BLS only: Employment Change Greatly Exceeds Test Parameters WIN-202 Only: Month 3 Employment Change Greatly Exceeds Test Parameters
092-W	AQW Change is Significantly > Parameter and Exceeds Twice the Quartile AQW Range
093-W	Average Employment is Significantly > Parameter, but Total Wages = 0
094-W	Average Employment = 0, but Total Wages Is Significantly > Parameter

Level 6 – Warning Macro Edits

Edit Code	Edit Message
126-W	EXPO & BLS only: Employment Change Exceeds Test Parameters
127-W	AQW Change > Parameter and Exceeds Twice the Quartile AQW Range
130-W	Average Employment > Parameter, but Total Wages = 0
131-W	Average Employment = 0, but Total Wages > Parameter
134-W	Number of Establishments out of Range
135-W	New or Discontinued Macro Record
136-W	WIN-202 Only: Month 1 Employment Change Greatly Exceeds Test Parameters
137-W	WIN-202 Only: Month 2 Employment Change Greatly Exceeds Test Parameters
138-W	WIN-202 Only: Month 3 Employment Change Greatly Exceeds Test Parameters

All the macro edits are Priority "A" edits as described in Section 13.3.3 or Appendix F. This means that macro flags should receive the highest priority for data review and cleanup. Before the deliverable EQUI file is transmitted each quarter, these flags should be corrected (by correcting data on the micro records) or explained (by assigning comment codes or narrative comments to micro records). For most of the edits listed, the micro and macro records are edited using identical or very similar formulas. This methodology results in consistent micro and macro edits. States cannot correct macro records directly, but must correct the micro record(s) that have caused the macro record to flag.

The first six edits listed, 089 through 094, are Level 5 edits (Significant Employment and Wage edits), while the rest are at edit Level 6 (Warning Edits). For each macro edit that screens employment or wage levels, there is a corresponding micro edit that uses the same edit code and message to flag establishments. Edits 134 and 135, which focus on the number of reporting units in a county-ownership-industry cell, are performed only at the macro level. Edit 134 flags a significant change in the number of reporting units (micro records) in the cell from one quarter to

the next. Edit 135 flags whole macro cells that never existed before or that cease to exist. Edit 135 is related to micro edits 096-W and 139-W that flag new micro records as well as to edit 140-W that flags discontinued micro records.

As with the micro edits discussed in Section 9.2, several of the Level 6 macro edits are the same as Level 5 edits, but performed with smaller [lesser value] parameters or tolerances:

Significant Level 5 Edit Code	Warning Level 6 Edit Code	Edit Description
091	126	Monthly Employment Change
092	127	AQW Change
093	130	Employment Without Wages
094	131	Wages Without Employment

The difference between a Level 5 edit and its equivalent Level 6 edit is typically based on a multiplier parameter. A crucial parameter or tolerance in the Level 6 edit is multiplied by the corresponding multiplier parameter. If the appropriate data condition exceeds the parameter/tolerance times the multiplier, the system assigns the Level 5 flag. If the data condition exceeds the parameter/tolerance but does not exceed the parameter/tolerance times the multiplier, the system assigns the Level 6 flag. This means that Level 5 flags identify data that are questionable at a greater order of magnitude than Level 6 flags. Therefore, Level 5 flags require more attentive review and, if the state verifies the data as accurate, a clear explanation via comment codes or narrative comments.

As an example of the difference between edit levels, edits 094 and 131 flag cells with zero employment in all three months and with significant wages. This pair of edits uses a wage parameter whose default is \$25,000, and a multiplier parameter whose default is 3. In the current quarter, a hypothetical macro cell has zero employment but has Total Wages of \$50,000. The \$50,000 wages on the macro record exceed the wage parameter and therefore the cell is flagged by the edit. However, the wages do not exceed \$75,000 (the wage parameter times the multiplier parameter). Therefore, the integrated edit assigns the Level 6 flag 131-W rather than the more serious Level 5 flag 094-W.

Options: Micro Edits Only, or the Full Integrated Edit

The standard state processing systems give states the option of editing current quarter data either at the micro level only or at both micro and macro levels together (the integrated edit). Early in the quarter, there are advantages to editing at only the micro level, since the current quarter's data may not be reported or may not be available for a significant portion of the state's reporting units. This allows the state staff to edit, correct, and assign comments before processing and reviewing the macro data. The integrated edit requires that both reported and imputed data (where necessary) are present. The macro portion of the integrated edit will not give accurate results if it is run so early that numerous reporting units have missing data and cannot be aggregated to the macro level. Imputation must be run for the units with missing data (as described in Chapter 8) before running the full integrated edit.

On the other hand, there are advantages to running the integrated edit fairly early in the cycle. State staff will find it easier to evaluate the impact of micro edit flags on the macro data, easier to monitor industry patterns, and easier to review all edit flags before the EQUI deliverable is due.

There are several processing options, described in Section 12.1 and Appendix E, which allow the state to make the most advantageous tradeoffs.

Situations That Cause Macro Flags

Employment or wage changes should be reviewed in the state systems prior to EQUI submittal using the macro edits, macro screens and edit output. Macro records are impacted by micro records and can flag for a variety of reasons, including:

1. Employment or wages change significantly on one or more of the micro records that comprise a significant portion of the macro cell. This is the situation the integrated edit normally identifies.
2. One or more micro records shifts from one cell to another cell, causing a large change in the macro cell's employment and/or wage levels, as discussed in Section 10.3. Micro records (establishments) shift cells whenever a change occurs in their county, ownership, or industry codes from one quarter to the next, thus impacting the macro data. This shift will impact two macro records (the one gaining employment and wages and the one losing employment and wages). The proper occasions and timing for changes to these classification codes are described in Section 2.3.
3. Micro records in the cell begin operations (births), cease operations (deaths), or otherwise change in ways that include or exclude them from the macro cell. For example, a record may change its Status Code from 9 (pending) to 1 (active) and thus enter the cell. When these types of micro record changes are large enough they will cause the macro cell to flag in the integrated edit.
4. Multi-establishment breakouts and collapses. For example, a record with Reporting Unit Number 00000 may change its Multi Establishment Indicator (MEEI) Code from 1 (single unit account) to 2 (master record) and the new subunits under the master record may, in effect, leave the cell. When these types of micro record changes are large enough they will cause the macro cell to flag in the integrated edit. Employment and wage changes in macro records due to changes in reporting by multi-establishments are generally considered noneconomic code changes. Follow the procedures described in Chapter 11.
5. Predecessor and successor changes. For example, if an establishment is sold and moves in its entirety from one UI account to another, the predecessor record must be inactivated (with Status Code 2 and an End of Liability Date) and the successor must become active (with Status Code 1 and a Date of Initial Liability) at the proper time. Inaccurate timing may create an overlap or gap in the reporting of the establishment's data for specific quarter(s), causing the macro data for the quarter(s) in question to incorrectly appear high or low.

Employment and wage changes in macro records due to predecessor and successor micro record changes are generally considered noneconomic code changes. Follow the procedures described in Chapter 11.

6. A significant portion of employment or wage data in the macro cell are imputed rather than reported. This can occur in the early stages of quarterly processing. The imputed data may vary significantly from the actual, reported data. Replacing the imputed data with reported data may increase or reduce the fluctuation in the cell and may therefore cause different edit outcomes.
7. Employment or wage data in the micro records that make up the macro cell are missing. This can happen when partial updates to micro records zero out the values not updated, or records that have been estimated for two quarters are not estimated for a third quarter.

10.3 Code Changes and Macro Data

The classification codes that identify and define the macro cell are the county, ownership, and industry codes. If one or more of these codes on a micro record is changed from one quarter to the next, then that reporting unit moves from one macro cell to another. This movement changes the economic data in both cells, and may affect editing in both cells when the edit compares data between quarters.

The Sstate may change classification codes for various reasons. Code changes fall into three basic types, as discussed in Section 2.3 and summarized below. The timing for implementing these code changes differs, as explained in Section 2.3.2.

1. Changes from Unclassified to Classified Codes – These changes typically occur when a reporting unit is originally established on the state system using unclassified industry or county codes (for example, County 999). When adequate information is obtained to assign a specific valid code, the state should introduce the code change onto to the file immediately, in any quarter.
2. Economic Code Changes – The state makes these changes at the time of a true economic event or by the end of the thirty-day clean up period of the quarter in which the event occurred. The time of the code change must be identifiable and not a gradual shift. For example, if a retail sales operation relocates to another county, and the state learns of the move in time to include the new county code in the data for the quarter when the move occurred, the change is considered economic. These changes should also be implemented immediately, in any quarter. Please note that corrections to coding are not economic code changes.
3. Noneconomic Code Changes – Noneconomic code changes include code changes for which it cannot be determined whether the previous code was incorrectly assigned, or when a change occurred between accurately assigned codes but was not reflected in the EQUI file for

the quarter in which it occurred. Most noneconomic code changes are identified during the Annual Refiling Survey (ARS). These code changes must be reflected in the first quarter only. The next section describes how the macro edit uses a special process to accommodate code changes that are properly identified and processed as noneconomic.

10.3.1 Code Change Integration for Noneconomic Code Changes

When the change in a reporting unit's classification codes is noneconomic, the state should follow the procedures in Chapter 11 to place that unit onto the Code Change Supplement (CCS) file. The state and the national office systems will then reflect that code change on the Summary of Differences file. The Summary of Differences file is described in Section 11.6 and its file layout appears in Appendix M.

The macro portion of the integrated edit uses the Summary of Differences file when editing first quarter, in a process called code change integration. Summary of Differences data are used to minimize the effect of the code changes by making a temporary adjustment to the following data elements on the macro record:

- Number of Establishments in first quarter
- January Employment (Month 1 employment in first quarter)
- February Employment (Month 2 employment in first quarter)
- March Employment (Month 3 employment in first quarter)
- Total Quarterly Wages in first quarter

Code change integration in the editing process compensates for the data fluctuations caused by the movement of units in and out of macro cells from fourth quarter to first quarter, provided that this movement (these code changes) appear on the CCS. Therefore, this temporary adjustment to first quarter data sharply reduces the effects of noneconomic code changes in certain macro edits.

Each noneconomic code change identified on a CCS record (and a micro file record) affects two macro cells: the cell from which the data leave, and the cell into which the data enter. More than one CCS record enter or leave the same cell; on occasion, some records are entering the same cell that other records are leaving. The net change on the cell may be positive, negative, or zero. This net change is applied during the temporary macro editing adjustment.

For purposes of code change integration, the Summary of Differences information shows net changes at the cell level for January, February, and March employment; for first quarter wages; and for the number of reporting units. The Current Employment Statistics (CES) program and other data users need CCS and Summary of Differences files showing December Employment and Fourth Quarter Wages. The CCS and Summary of Difference files include December through March employment as well as Total Quarterly Wages for fourth and first quarter.

The state and the national office systems use non-adjusted data for comparison when editing second, third, and fourth quarter data. The systems use adjusted data for comparison when

editing first quarter data. Though CCS adjustments are temporarily applied to first quarter data when first quarter is being edited, only non-adjusted data are maintained on the macro and micro files, including the macro and micro files for the first quarter. Also, keep in mind that prior quarter data may be edited along with current quarter data during current quarter processing. For example, first quarter data may be edited during second quarter processing. During that second quarter processing, the first quarter data are temporarily adjusted when the first quarter is the quarter being edited. If second quarter is the quarter being edited, data for first and second quarter are left unadjusted, and second quarter is edited as described in Appendix F.

Code change integration works each time first quarter data are processed through the integrated edit as either the current or prior quarter. The requirement that noneconomic code changes be properly identified and held for first quarter activation ensures that all users benefit from the special features applied to first quarter editing. These features are not available when second, third, and fourth quarter data are edited.

The following macro edits for employment, wages, and number of reporting units are adjusted by code change integration in first quarter:

Edit Code	Edit Message
091-W	Employment Change Greatly Exceeds Test Parameters
092-W	AQW Change is Significantly > Parameter and Exceeds Twice the Quartile AQW Range
126-W	Employment Change Exceeds Test Parameters
127-W	AQW Change > Parameter and Exceeds Twice the Quartile AQW Range
134-W	Number of Establishments out of Range

Code change integration is only performed for the most recent first quarter on the file. For example, when the current processing quarter on the state system is the 2018/1, the system will use Summary of Differences information to temporarily adjust 2018/1 data when that quarter is processed through the integrated edit.

When first quarter is processed through the integrated edit, macro edits 091-W and 126-W compare each month of employment to the previous month, and then to the same month a year ago. January is compared to December and to last January; February is compared to January and to last February; March is compared to February and to last March. Edits 092-W and 127-W compare first quarter wages to fourth quarter wages and then to year-ago first quarter wages. Therefore, the net change due to noneconomic code changes is calculated for the employment of each month (January, February, and March) and for first quarter wages. The number of establishments entering and leaving the cell is also calculated. The net changes are subtracted from January, February, and March employment, from first quarter wages, and from the first quarter number of establishments. Then those fields are edited using the normal macro edit formulas. By making these adjustments for movement due to noneconomic code changes, first quarter data can usually pass the edits that compare them to the period immediately prior.

States may find it necessary to run the integrated edit (including the code change integration routine) more than once when processing first quarter, since the first quarter cleanup process may include additional industry, county, or ownership code changes on micro records. Once corrections are made, corrected summary of differences data can be generated and used in a final integrated edit before the state generates the first quarter deliverable. The national office re-runs the data through the full integrated edit (both micro and macro editing) whenever a state provides updates.

Another aspect of code change integration is the display of Summary of Differences data on edit listings. Sometimes the edit adjustment does not remove all macro edit flags. When a macro cell is flagged for any reason and is displayed on edit listings, any Summary of Differences data for that cell are displayed with the macro data. In Section 13.3, EXHIBIT 13P (EQUI Table 9A), Summary of Differences data are displayed just below the flagged macro data.

10.3.2 Other Code Changes

Code change integration controls the effects of noneconomic code changes on the first quarter macro edit; however, various situations can lead to other types of code changes. Since code changes move micro data from one macro cell to another, they can cause one or more macro flags. Where the code changes are inappropriate (or are introduced at the wrong time), the state should make the necessary correction to the classification code. This normally requires (1) recoding the establishment to its former classification, (2) waiting until the first quarter of the following year to make the code change, and (3) including the record on the CCS. Where the code change is proper (or are economic in nature), the states should assign the appropriate comment code to the micro record that changes. Where the impact of the code change is significant, also adding an appropriate narrative comment can help data users interpret the situation more accurately and may preclude follow-up questions from the national office and BEA. Comment codes and narrative comments are discussed in Appendix I and in Section 9.6.

Changes from Unclassified County or Industry Codes

When a reporting unit with the unclassified industry code (NAICS 999999) can be assigned a specific, valid code, the code change should be made immediately, in the current quarter. Similarly, when a unit that carries any of the county equivalent codes (County 995-999) can be changed to a specific code, the change should occur immediately. Code changes of this type improve the accuracy of the data, but may cause macro edit flags as the units shift between cells. Assign comment code 80 (change in unclassified to classified) to the affected micro records. Changes from classified to unclassified must follow the rules of normal noneconomic code changes.

Economic Code Changes

Economic code changes are changes from one specific, accurately assigned industry, county, or ownership code to another. This type of change must be implemented in time to reflect the actual economic event (typically a change in business activity or a relocation). It should be reflected in QCEW data in the same quarter which is affected by the economic event. Refer to Section 12.2.3 for additional information on the QCEW Corrections Policy.

Corrections to coding (such as errors) are never economic and must be introduced in first quarter data. As an example, if a state is working on their second quarter data and identify a coding error that occurred in first quarter, the state can go back to first quarter and make that correction, rather than holding the correction until next year's first quarter. See Section 2.3.2 for additional information concerning timing and reporting of code changes.

As with other types of code changes, economic code changes may cause the unit's present or former macro cell to flag. The state and the national office systems use a data element to identify these changes, called the Economic Code Change Indicator (discussed in Appendix B).

Predecessor/Successor Transitions

When an establishment changes owners and is transferred to a new UI/RUN account, new information on the business activity or geographic location may become available that requires a change to the industry, county, or ownership codes. (Procedures are described in Section 5.3.) If the unit has significant employment, the code change should be treated as noneconomic.

For smaller units (with 25 or fewer workers in the last month before or the first month after the change of ownership), the state may assign the correct codes in any quarter. This policy is spelled out in Section 5.3.

Code changes of this sort can cause a macro edit flag where the macro cell is small, or if several of these code changes occur for the same cell. Assign comment code 93 (full predecessor/successor transfer) to the micro records in question, and provide the appropriate Predecessor or Successor UI/RUNs as described in Section 5.1.

Breakouts and Consolidations of Multi-unit UI Accounts

When a UI account reporting as a single unit begins to report as a multi, some of the new subunit records may belong in a different county or industry than the former single unit. Similarly, if an account will no longer report as a multi but will be consolidated to report as a single-unit account, classification coding may change. Some subunits may be inactivated whose county or industry codes differ from the codes on the collapsed single.

These changes in reporting level can move employment and wage data between macro cells, even though no economic event caused the movement. **Code changes of this sort are noneconomic code changes.** They must be held until the following first quarter and assigned

the necessary coding to include them on the CCS and Summary of Differences. Code changes of this type are explained in Sections 5.5 (for breakouts) and 5.6 (for consolidations).

10.4 Macro Data Review

The states and regional offices are required to review high level macro data in addition to reviewing output from the integrated edit after the EQUI has been submitted. Reviewing aggregated data for consistency as well as irregularities can be a powerful supplement to the standard set of edits.

As explained further below, states generate and send a macro data summary file at specified times in the production cycle to their regional office. Regional offices and states review the data using the CES/QCEW Macro Roll-Up Spreadsheet and correct the data as necessary. This spreadsheet is generated using the macro data summary file as well as CES data. The spreadsheet provides graphical and tabular representations of aggregated QCEW data. States should aggregate the data in the spreadsheet to statewide.

The CES/QCEW Macro Roll-Up Spreadsheet was developed and is maintained in the regional offices. It is used to compare the state QCEW employment data against state CES data and to compare current year QCEW trends against prior year QCEW patterns in both employment and wages.

This review will alert staff at all levels to reporting problems in either of the programs, as well as to any large data discrepancy. This review should uncover any large data errors before the initial EQUI and subsequent update files are submitted to the national office. It also reduces the time spent uncovering and tracking large data and production problems in both the regional office and the national office.

Before the state generates and sends the initial quarterly EQUI file to the national office, the regional office reviews the macro data using this tool. The regional office reviews each update file in the same way. State QCEW staff must use the same tool, or similar approaches, to examine their own data to identify potential problems. The regional office sends the latest spreadsheet as a zipped Excel file via e-mail using a specific naming convention to the national office (see Appendix S), where it is used to supplement the data review described in Section 13.3.1.

This macro data summary file is created by the state systems both as a separate job and as a part of the job that creates the EQUI file.

The national office compares the spreadsheets against EQUI edit listings as well as the listing of state ownership totals (BLS Table 2A). The national office will alert the regional office (and system developers, if appropriate) to potential errors or significant data discrepancies. The regional office will research the problem, contact the state if needed, and report their findings to the national office.

Processing Sequence

Each state is required to generate a macro data summary (using the appropriate features of their standard state processing system) at the following points in the quarterly processing cycle, and to send the file to the regional office.

1. Two weeks before generating the initial EQUI file
2. The day the initial EQUI is generated
3. Two to five days before generating an EQUI update file (optional, recommended)
4. The day each EQUI update file is generated (optional, recommended)
5. The day each EQUI subset file is generated (after rebuilding the macro)

At points 2 and 4 (generating a macro data summary file on the same day as an initial EQUI file or EQUI update file), the macro data summary and the EQUI file should be fully consistent, with no intervening updates to the micro data. States should limit the number of update files to no more than one per quarter. If serious problems are identified, a subset file may be submitted from the state only upon receiving the national office approval. States should strive to send in an EQUI file that does not require an update file. If the quality of the state's EQUI file requires an EQUI update file, it must be transmitted to the national office in time to meet the cleanup deadline. Regional offices work with their states to ensure that the updated data are edited and reviewed prior to submission of the update transactions to the national office. State processing schedules may need to be adjusted to allow for this editing and review. States and regional offices also need to allow time for the updates to be received and processed by the national office.

Steps for Macro Data Review

The state and regional office follow these steps each time a macro data summary is required.

1. The state generates the macro data summary and sends it to the regional office as a plain text file, using a standard naming convention. The files must follow the following naming convention:

MacroYYQSTVn.txt

YY = Two-digit year

Q = Quarter

ST = Two-character state abbreviation

V = File version: Use I for initial files. Use U for update files.

n = File number: Use 1 if it is the first initial file or first update file.
Use 2 for the second version of either file.

2. For example, a macro data summary file corresponding to an initial EQUI file from Delaware, containing 2017, first quarter data would be named Macro171DEI1. The regional office reviews the data using the CES/QCEW Roll-Up Spreadsheet. If any large data errors are found, the regional office notifies state QCEW staff immediately. When

the macro data summary is generated at the same time as an EQUI file, the regional office also notifies the national office of any large data errors.

3. The state reviews the macro data summary using the CES/QCEW Roll-Up Spreadsheet. When the macro data summary is generated at the same time as an EQUI file, the state conducts this review before transmitting the file.
4. The state researches and corrects (if necessary) any data discrepancies or errors.
5. The state QCEW staff alerts state CES staff of any large data errors.

Chapter 11 – Code Change Data: Concepts, Rules, and BLS Processing

The Code Change Supplement (CCS) is a file of reporting units with a noneconomic change to one or more of the essential classification codes – industry, ownership, county, or (for certain States) township. Both the state and the national office systems generate the CCS and its more aggregated equivalent, the Summary of Differences file, using data from their state systems. Enhanced Quarterly Unemployment Insurance (EQUI) file transactions keep state and the national office versions of these files essentially consistent.

This chapter describes how the CCS and Summary of Differences files are generated and processed in the national office. Processing in the standard state systems (EXPO and WIN) is somewhat similar. The user documentation for EXPO and WIN provide detailed instructions about performing essential tasks for CCS processing.

----- Contents of Chapter 11 -----

- 11.1 Overview of CCS Processing
- 11.2 Micro File Data Elements for the CCS
- 11.3 Generating the CCS File
- 11.4 Micro Edits and EQUI Updates for the CCS
 - 11.4.1 Micro Edits That Affect the CCS
 - 11.4.2 Updating Response Codes, Old Fields, and Other Data
 - 11.4.3 The National Office System Reassigns Some ARS Response Codes
- 11.5 Code Changes for Special Cases
 - 11.5.1 Multi-unit Breakouts with Code Changes
 - 11.5.2 Multi-unit Collapses with Code Changes
 - 11.5.3 Predecessors and Successors with Code Changes
 - 11.5.4 How the System Handles Missing Employment or Wages
 - 11.5.5 When Out-of-Business Units Have No Successor
- 11.6 Generating the Summary of Differences File for the Integrated Edit
- 11.7 Printed Output from CCS Processing
 - 11.7.1 CCS Table 1: Response Code Change
 - 11.7.2 CCS Tables 1A and 1B: Code Changes for Large Records
 - 11.7.3 CCS Table 2: CCS Creation Counts Report
 - 11.7.4 Missing Code Changes, Problem Response Codes, and Other Reports
 - 11.7.5 Summary of Differences Reports
- 11.8 Additional National Office Processing of Code Change Data
- 11.9 Cleaning CCS Data

11.1 Overview of CCS Processing

The national office system generates the CCS directly from its micro file (the QCEW database of micro level reporting units) by examining and comparing certain relevant fields. The CCS is primarily used for first quarter processing. For each affected reporting unit, the CCS file shows noneconomic changes made to industry, area, or ownership codes. Noneconomic code changes are held until first quarter, so code changes on the CCS represent changes made in the State system from fourth quarter to first quarter.

State staff are responsible for identifying the reporting units that belong on the CCS, including those introduced by EDI Center records, and for making the necessary updates in their State processing system that will place these units on the CCS. Noneconomic code changes that are properly entered on the Annual Refiling Survey (ARS) Control file are automatically included on the CCS file, both in the States and in the national office. If State staff do not enter the code changes on the ARS Control file, they must enter them directly to their State system and include the necessary data elements (described in Section 11.2).

On the CCS file, the essential data elements include the Old and New fields. The Old fields (Old NAICS, Old Ownership, Old County, and Old Township) are similar in purpose to the Old fields on the EQUI and the State system. They show where the employment and wage data for that unit were reported in fourth quarter. The New fields (New NAICS, New Ownership, New County, and New Township) show where the data have moved in first quarter, whenever the first quarter code is different from the fourth quarter code. The CCS record also includes some of the employment and wage data fields for fourth and first quarters to show the magnitude of the change.

EQUI corrections and updates can change the micro file in ways that affect the CCS, so the national office system regenerates the CCS each time an EQUI file is processed. This begins with the quarterly deliverable for first quarter and continues through the second quarter EQUI clean-up period. The State systems translate changes into EQUI transaction records for the national office, and the national office system uses the EQUI records to update its own micro file. This keeps the national office micro file consistent with the State's file, at least for active, covered reporting units in recent quarters. BLS provided its CCS software to the developers of the State systems so that all the systems can use the same logic for generating the CCS and Summary of Differences files (and for other CCS-related processing). This means that the CCS and Summary of Differences in the States can remain largely consistent with the files generated by the national office.

The Summary of Differences gives CCS information aggregated to a macro level. For a county/ownership/industry cell affected by a CCS record (or records), the Summary of Differences reports the employment, wages, and number of units entering or leaving that cell. The national office system regenerates the Summary of Differences file each time it processes an EQUI file and generates the CCS. Therefore the Summary of Differences corresponds exactly to the CCS – that is, all changes to the CCS are reflected in the Summary of Differences.

For purposes of the CCS, a noneconomic change to "area" normally consists of a change to the FIPS county code. However, for States that are required to report township codes on the EQUI, a change to the township code may also be noneconomic, even if this change occurs within the same county. In other words, for certain States (the New England States and New Jersey) a CCS record may report a change only to the township code. For all States, the aggregated Summary of Differences file (in contrast to the base CCS itself) reflects noneconomic code changes only to county, ownership, and industry code, not to township.

As with the macro file, the system excludes master records (records with Multi Establishment Employer Indicator (MEEI) of 2) from the CCS and Summary of Differences files. Unlike the macro file, the system can include inactive records on the CCS and Summary of Differences. This is because inactive records may provide some of the essential code change information for special cases such as predecessors with code changes and multi-unit collapses. This is explained in Section 11.5, and in Sections 5.3 and 5.6.

The CCS and Summary of Differences only apply for the most recent first quarter. For example, suppose the current processing quarter is the 2020 first quarter (2020/1). State and the national office micro files will contain data for both 2020/1 and 2019/4. Under the BLS correction policy described in Section 12.2.3, both 2020/1 and 2019/4 will be unlocked and available for updating. Nonetheless, the system will generate a CCS and Summary of Differences only for the most recent year (in this example, 2020). Code change data for earlier years would have little if any value for data users.

11.2 Micro File Data Elements for the CCS

Beginning with the first quarter EQUI deliverable and continuing through second quarter, the national office system will use the following non-quarterly fields when generating and then re-generating the CCS:

- ARS Response Code
- ARS Refile Year
- Old NAICS
- Old Ownership
- Old County
- Old Township

These fields must be correct on the State and the national office micro files for the CCS records to be correctly produced.

The national office system (and the State systems as well) use the ARS Response Code and ARS Refile Year to recognize records that are intended for the CCS. The system also compares first quarter classification codes (NAICS code, ownership, county, and sometimes township) to the "Old" fields to determine whether a true code change is present. The system uses the MEEI code to exclude master records. It uses the Status Code to exclude records that are not active in either

first or fourth quarter. ARS Response Code, ARS Refile Year, and the Old fields are non-quarterly fields (occurring only once on the micro file) while the other fields mentioned are quarterly.

Once the system chooses a record for the CCS, it copies a number of data elements from the micro file to the CCS. The complete list of CCS data elements is given in Section 11.3.

ARS Response Code and ARS Refile Year

The ARS Response Codes that signal the presence of a noneconomic code change are these:

- 46 – Clean record with CCS updates
- 50 – Code change from non-ARS sources

The ARS Response Code may be very recent, or it may have been updated in earlier years. Therefore the system also uses the ARS Refile Year field in choosing records for the CCS. If the ARS Response Code is 46 or 50, and if the ARS Refile Year is current, then the record is included (although there must also be a true CCS code change, as discussed below). “Current” in this case means that the ARS Refile Year is the same as the year of the most recent first quarter.

The following examples illustrate how these two fields are used. For all three cases, assume that the national office has begun processing first quarter data, so 2020/1 is the micro file’s current quarter.

1. A record that was surveyed in the FY 2020 ARS includes a code change that the state entered onto its ARS Control file. The record has an ARS Response Code of 46. When the state processing system passed FY 2020 ARS data to the micro file, it assigned an ARS Refile Year of 2020. Therefore this reporting unit carries ARS Response Code 46 and ARS Refile Year 2020 on the EQUI and the national office micro file. If all other necessary conditions are met, this record will be included on the CCS.
2. A micro file record has an ARS Response Code of 46 and ARS Refile Year of 2019. This indicates that it had a noneconomic code change in the previous year’s ARS (and was included on the 2019 CCS.) The record will not be included on the CCS now because the ARS Refile Year field is not current. That is, 2019/1 is not the most recent first quarter on the micro file.
3. A micro file record has ARS Refile Year 2020 and ARS Response Code 41 (meaning: Reviewed, no CCS code changes). Even though the ARS Refile Year is current, the system will not put the record onto the CCS because the ARS Response Code is not 46 or 50. Even if one or more of the classification codes changed from 2019/4 to 2020/1 on this micro file record (for example, a code change discovered and applied after the ARS), ARS Response Code 41 will exclude the record from the CCS file in the national office. It will be excluded in the state version of the CCS as well. Section 11.4.3 describes the reassignment of ARS Response Codes by the national office system.

“Old” Fields and CCS Code Changes

The following are the relevant “Old” fields on the micro file for CCS code change purposes:

- Old NAICS
- Old Ownership
- Old County
- Old Township

The system compares the Old fields with the corresponding first quarter codes (typically the NAICS code, ownership, and county) to determine whether a true CCS code change is present. A code change occurs when an Old field is not blank, and it differs from the first quarter code. Remember that the CCS shows changes from fourth quarter to first quarter, so a non-blank Old field should normally be the same as the corresponding fourth quarter classification code.

There can be special circumstances (described further in Section 11.5 and in Chapter 5) in which the fourth quarter classification code fields cannot be used to hold the code change aside through fourth quarter. The Old fields serve this purpose instead, and may differ from the fourth quarter codes in those unusual circumstances.

A record has a **true** CCS code change if it contains at least one of the following:

- An ownership code change, or
- A NAICS code change other than a change from the unclassified code (from 999999), or
- A county code change other than a change from a county equivalent code (from 900, 995, 996, 998, or 999), or
- For New England States and New Jersey only, a township code change other than a change from a township equivalent code (from 900, 995, 996, 998, or 999).

The county equivalent codes are defined as follows:

- 900 = master record
- 995 = Statewide, locations in more than one county, or no primary county
- 996 = foreign locations
- 998 = Out-of-State locations
- 999 = unknown locations

The township equivalent codes have essentially the same definitions. An area change from any of these equivalent codes, as well as a NAICS change from 999999, is considered as a "change from unclassified" rather than as a specific, noneconomic code change.

Consider the following examples:

Case #	Old NAICS	First Quarter NAICS	Old County	First Quarter County	Old Own	First Quarter Own	CCS Code Change record?
1	327215	327215	035	035	5	5	No
2	541990	561599	013	013	5	5	Yes
3	999999	322220	999	999	5	5	No
4	721214	721214	995	111	3	3	No
5	812332	812332	999	995	5	5	No
6	999999	523110	013	035	5	5	Yes
7	221111	221113	999	023	5	5	Yes
8	562920	221320	023	023	3	5	Yes
9	211112	211112	329	329	2	5	Yes

1. In case 1, no Old fields differ from the corresponding first quarter code. The system will not put this record on the CCS.
2. The record in case 2 has an industry code change from one specific, valid code to another. Therefore if the other conditions (ARS Refile Year, ARS Response Code, and MEEI) are met, this record will appear on the CCS.
3. Case 3's only change from Old fields to first quarter codes is an industry code change from 999999. As described in Section 2.3.2, this is a change from unclassified rather than a noneconomic code change. It does not belong on the CCS, so ARS Response Codes 46 or 50 are not correct for this situation. If the record carries an ARS Response Code, it should be 41 (Reviewed, no CCS change).
4. Case 4 is also treated as a change from unclassified because its only code change is a county change from one of the county equivalent codes. It will not be placed on the CCS.
5. The county code change in case 5 is like case 4. Because it is not a change from one specific county to another, it will not appear on the CCS.
6. Even though case 6 has an industry code change from the unclassified code 999999, it also has a legitimate, specific county code change. Therefore the system will include this record on the CCS.
7. Case 7 also combines a change from unclassified (for county) with a legitimate, specific noneconomic code change (for industry code). It will therefore appear on the CCS.
8. Case 8 has a code change between ownerships and industry code. Either one is sufficient to qualify the record for the CCS. This record will appear on the CCS.
9. Case 9 has a code change from State ownership to private ownership. This record will also appear on the CCS.

For most States, the system will not consider the Old Township field when creating records for the CCS. Township codes are required and edited only for New Jersey and the New England States; therefore a change only to township code may be treated as noneconomic only for these States. For example, if a record on the New Hampshire file has a township code change while its county, ownership, and industry code remain the same that record will qualify for the CCS. An identical record on the Texas file will not.

MEEI and Status Codes

Master records do not belong on the CCS and Summary of Differences files since they represent an aggregated duplication of the real reporting units. Including master records would exaggerate the movement of reporting units, employment, and wages between macro cells. The system checks the MEEI code in first quarter and the preceding fourth quarter. If a record has an MEEI of 2 (master record) in either quarter, it will not be included on the CCS.

Some records (some UI/RUNs) change from masters to single-unit records or from single-unit records to masters when multi-unit reporters break out or collapse. These changes often occur from fourth to first quarter. Sections 11.5.1 and 11.5.2 cover this in some detail. It is also discussed in Chapter 5.

Breakouts and collapses of multi-unit accounts often involve subunit records that report a noneconomic code change and that are active in only one of the two affected quarters. The national office system checks Status Codes on records marked for the CCS to ensure that either first quarter, fourth quarter, or both are active (Status Code = 1). If neither quarter is active, the system excludes the record from the CCS and Summary of Differences files.

11.3 Generating the CCS File

The national office system generates the CCS file (file format shown in Appendix L) primarily by copying data elements from qualifying records on the micro file, although it uses parameters as well. The previous section (Section 11.2) explains how records qualify for the CCS, based on ARS Refile Year, ARS Response Code, MEEI, Status Code, and the presence of a true CCS code change. The essential first quarter classification codes (for most States, the county, ownership, and industry codes) must all be present on the record. At least one Old field must be present that differs from the equivalent first quarter code. The system will also verify that the necessary employment and wage fields are present.

Sources for the CCS Data Elements

The national office system assigns CCS data elements as follows:

From parameters:

- State FIPS Code
- ARS Refile Year

(The documentation for your state system explains the assignment and use of parms.)

Copied from non-quarterly fields on the micro file record:

- UI Account Number
- Reporting Unit Number (RUN)
- Employer Identification Number (EIN)
- Name (Trade Name if present, otherwise the Legal Name)

Copied from the most recent first quarter on the micro file record:

- MEEI code
- January Employment – from Month 1
- February Employment – from Month 2
- March Employment – from Month 3
- First Quarter Total Wages

Copied from the fourth quarter immediately preceding the most recent first quarter on the micro file record:

- December Employment – from Month 3
- Fourth Quarter Total Wages

Copied from Old Fields and first quarter classification codes on the micro file record:

- Old NAICS code
- Old Ownership code
- Old County code
- Old Township code
- New NAICS code
- New Ownership code
- New County code
- New Township code

Fourth Quarter Fields, First Quarter Fields, Old Fields, and New Fields

The national office system copies the Old fields from the micro file record (Old NAICS, Old Ownership, Old County, and Old Township) to the Old fields in the CCS record. The system copies the first quarter classification field code to the New field of the CCS record where it differs from the corresponding CCS Old field.

Unlike the standard state systems, the national office system can generate a CCS record if one or more of the essential Old fields (Old NAICS, Old Ownership, or Old County) is blank. If there are Old fields without data (that is, blank), then the national office system copies the value from the corresponding first quarter code into the Old field of the CCS record. For example, if Old NAICS is blank, the first quarter NAICS code from the micro file record is copied to Old NAICS code on the CCS record.

Here are several examples. Townships are not shown because for most states, township codes are not required and do not affect their CCS files.

Codes	Micro File Old Field	Micro File 4 th Quarter Field	Micro File 1 st Quarter Field	CCS Old Field	CCS New Field
<i>Example 1</i>					
NAICS	811213	811213	811211	811213	811211
Ownership	(blank)	5	5	5	(blank)
County	(blank)	033	033	033	(blank)
<i>Example 2</i>					
NAICS	811211	811211	811211	811211	(blank)
Ownership	5	5	5	5	(blank)
County	005	005	033	005	033
<i>Example 3</i>					
NAICS	(blank)	221113	221113	221113	(blank)
Ownership	(blank)	5	5	5	(blank)
County	013	025	025	013	025

Notice that all Old fields are assigned on the CCS, even when the Old field is blank on the micro file. Meanwhile the CCS New fields are only assigned when the code changes. Where the CCS New fields are present, they are consistent with the first quarter fields. Where the CCS New fields are blank, the fourth quarter and first quarter fields are the same – the code did not change.

In the first two examples, the Old fields on the micro file, when present, are identical to the fourth quarter fields. This will be the typical situation. However in Example 3, the micro file Old fields are not consistent with the fourth quarter fields. Old County is 013 while the fourth quarter county is 025. The system copies 013 to the Old County field on the CCS and ignores the fourth quarter county code. There are special circumstances (discussed in Section 11.5 and in Chapter 5) in which the fourth quarter is inactive or pending (Status Code = 2 or 9) and the Old fields may differ from the fourth quarter fields. Example 3 could be one such case – a newly broken out multi worksite record, with pending status in fourth quarter and active status (Status Code = 1) in first quarter.

However in the normal case, in which the fourth quarter of the record are active, the Old fields should be identical to the fourth quarter classification codes. The standard state systems will set the Old fields equal to the fourth quarter codes in that case. If for some reason they differ on the EQUI (and the national office micro file), the micro edit in the national office will assign a W (Warning) flag, as discussed in the next section.

The national office system will not create a CCS record if any of the required first quarter codes are missing (blank). In other words, the first quarter industry, ownership, and county codes (plus the township code for New England states and New Jersey) must all be present on the micro file. This becomes significant when the first quarter of the record is inactive or pending, because a blank code (for example, a blank NAICS code) is normally harmless when the quarter is not active.

11.4 Micro Edits and EQUI Updates for the CCS

The national office system does not directly edit either the CCS or Summary of Difference files. Instead it edits the relevant data elements, and key relationships between them, on the micro file. Correcting these errors on their respective state system allows both the state and the national office to generate more complete and accurate CCS files.

For some edits discussed in Section 11.4.1, an edit failure (a flag) causes the national office system to change the ARS Response Code on its micro file. This, in turn, excludes the record from the CCS. When the state corrects the error, the national office system changes the ARS Response Code again in a way that allows the record to be included on the CCS. Most micro edits do not affect the ARS Response Code and therefore do not exclude the record; however, correcting the micro file record results in a more accurate CCS record. In the national office system, all of the I-errors and W flags discussed in the following section will appear on Table 9B, the Micro Edits Only listing.

Section 11.4.2 explains how the content of the CCS can be changed when certain fields on the micro file are changed (via the EQUI), especially the ARS Response Code and the Old fields. Section 11.4.3 explains how the national office system changes ARS Response Codes.

11.4.1 Micro Edits That Affect the CCS

Some edits have no effect on the CCS (for example, edits for taxable wages, contributions, or address fields). However, a number of micro edits related to the quality of the data copied to the CCS, and some edit flags prevent records from being included on the CCS file in the national office (and possibly in the states as well). To generate an accurate CCS file for their own use and in BLS, states should update their state system with corrections to the I-errors described in this section. They should also correct the W-flags that identify inaccurate codes or other data.

I-errors that Prevent Records from Being Included on the CCS

As discussed in Section 11.2, the national office system uses the ARS Response Code on the micro file as a primary criterion to include records on the CCS. If ARS Response Code is not 46 or 50, then the record will not be chosen. However, the system may change the ARS Response Code on the state system, based on what happens in micro editing. In particular, certain I-errors

cause the system to change the ARS Response Code in a way that excludes invalid data from the CCS. When EQUI transactions correct the errors on the national office micro file, the system changes the ARS Response Code in a way that allows the record to be selected again. This is explained in more detail below, in Section 11.4.3.

The I-errors in question follow. The last column in this table shows which quarter's data applies. "First" and "fourth" refer to the most recent first and fourth quarters. For example when 2020/1 is the current quarter, the national office will be creating the 2020 CCS. Invalid NAICS codes in 2019/1 through 2019/3 would require correction but would not affect the ARS Response Code – or the CCS.

Edit Code	Edit Message	Edit Quarter
010	Invalid NAICS Code	first
012	Invalid Ownership Code	first
013	Invalid County Code	first
016	NAICS & Ownership Inconsistent	first
031	Invalid First Month Employment	first
032	Invalid Second Month Employment	first
033	Invalid Third Month Employment	fourth and/or first
034	Invalid Total Wages	fourth and/or first
065	Inconsistent County/Township Combination	first
074	Invalid Old Ownership	non-quarterly edit
075	Invalid Old County	non-quarterly edit
076	Invalid Old County/Old Township Combination	non-quarterly edit
078	Invalid Old NAICS Code	non-quarterly edit

Edits 074, 075, 076, and 078 are performed only when the ARS Refile Year and ARS Response Code indicate that the record is intended for this year's CCS. These edits require that the Old fields, if not blank, contain valid codes. For example, edit 078 flags the Old NAICS code if it is not a valid code, while edit 075 flags the Old County if it is not a valid FIPS county code for the state or a valid county equivalent code.

Note that code 900 will flag as invalid in the Old County (and Old Township) fields. This is because code 900 is a county (and township) equivalent code that may only be used on master records. The CCS Old fields should identify the county-ownership-industry code macro cell where the economic data were reported in fourth quarter. Master records are always excluded from the macro file as well as the CCS, so the Old fields should never correspond to a master record. As Section 11.5.2 describes, multi-unit UI accounts that collapse into a single-unit account should never use the former master record as the source of any Old fields for the CCS.

Other CCS-related Edits

When you address Warning (W) flags for any of the employment and wage fields that will later be copied to the CCS, you can improve the CCS data. Beyond this, there are edits that were specifically implemented to promote a more accurate and complete CCS file.

1. Invalid ARS Response Code/Year (Edit 046-I) – If the record belongs on the CCS but its ARS Response Code or ARS Refile Year field are invalid, it will not be included. Assigning ARS Response Code 46 or 50 is not sufficient; a record intended for the CCS must also have a current ARS Refile Year. If the ARS Response Code was assigned in the current ARS or in a subsequent update to the state system, the ARS Refile Year should equal the current processing year.
2. Expected Code Change not Made (Edit 123-W) – This edit flags records whose ARS Refile Year and ARS Response Code signal that the record is intended for the CCS; however, the relationship between Old fields and first quarter codes does not indicate a true CCS code change. (A true noneconomic code change for the CCS is defined in Section 11.2). Check the Old codes and the ARS Response Code to see which field or fields should change.
3. Code Change Back to a Recent Code (Edit 121-W) – This edit identifies records whose codes have changed twice within the past year. Such frequent code changes are rarely appropriate, and should be researched thoroughly. Some records with this flag may have appeared on last year's CCS and also qualify for this year's CCS. The national office may require an explanation for these units.
4. Possible Noneconomic Code Change (Edit 120-W) – This edit flags records with code changes occurring in second, third, or fourth quarter. Such code changes should be checked to verify that they are truly economic in nature. If the code change is noneconomic, it should be held until first quarter and reported on the CCS, using the procedures described in the next section. In first quarter, this edit flags records with code changes that do not carry an ARS Response Code and ARS Refile Year for inclusion on the CCS.
5. Old Codes Are Inconsistent with 4th Quarter Codes (Edit 146-W) – This edit flags records whose Old fields, if present, do not match the corresponding fourth quarter classification code (for example, the Old NAICS and the fourth quarter NAICS fields contain different codes). The edit is only performed when the ARS Refile Year and ARS Response Code indicate that the record is intended for this year's CCS, when the record is active in fourth quarter (Status Code = 1) and edit flags 074, 075, 076, and 078 have not been assigned.

Edit 146 reflects two characteristics of noneconomic code changes reported on the CCS:

- The code change must be held until first quarter and not implemented earlier; and
- CCS records report changes only from fourth quarter to first quarter, not from (for example) third quarter to the following first quarter.

On occasion, a record in the state may carry a different classification code on the ARS Control file than on the fourth quarter of the state system. Since the Old fields are typically passed from the ARS Control file to the state system, a difference between the Old fields and

fourth quarter codes can occur. For example, the county code present on the FY 2020 ARS Control file may be the one used in the 2019 first quarter. If the county code on the state system record had an economic code change between 2019/1 and 2019/4, the Old County field passed from the ARS Control file to the state system will differ. To accommodate these situations, the state systems will set the Old fields on their micro files equal to the corresponding fourth quarter classification codes, when fourth quarter was active. This action by the state systems should prevent or minimize the instances of edit flag 146-W in the national office.

Some records with an inactive or pending fourth quarter may belong on the CCS and should contain Old fields; however, their Old fields might differ from their fourth quarter classification codes. Subunit records created for a new Multiple Worksite Report (MWR) breakout are an example. (See Section 11.5.1 and Section 5.5.) Edit 146-W will not be performed for these records because their fourth quarter is not active. However, their first quarter must be active to be included on the CCS.

11.4.2 Updating Response Codes, Old Fields, and Other Data

State staff can update the national office micro file by changing the same data elements on their own state system. Their state systems generate EQUI files that apply these same changes in the national office. State staff should make these data changes not only to correct errors, but also to make appropriate adjustments to the content of the CCS and Summary of Differences files in the national office (as well as the states). For example, correcting employment or wage data on the state system and the EQUI for certain time periods also corrects the comparable data on the CCS.

As mentioned before, the state controls what records appear on the CCS file primarily by updating the ARS Response Code. The ARS Refile Year must also be current, and Old fields must be present that show where the economic data were reported in fourth quarter.

ARS Response Code

On the state's ARS Control file, a record's ARS Response Code reflects its progress through the survey, whether a response has been received and whether its final response has been recorded. This data element is central to the calculation of usable and total response rates.

On state and the national office micro files, the ARS Response Code has more limited purposes. The ARS Response Code here is not used to calculate response rates. It has two uses, listed in order of precedence:

1. CCS Selection – The ARS Response Code is the primary indicator used to determine if a record does or does not belong on the CCS – but only when the ARS Refile Year is current.

2. ARS Status – The ARS Response Code shows what progress the record made through the refiling survey, as of the time this data element was transferred from the ARS Control file to the State system. Preferably it records a usable employer response. Meanwhile the ARS Refile Year field shows whether the code reflects the most recently completed survey, or an earlier ARS.

These purposes may occasionally conflict, in which case the first purpose (CCS) takes precedence. For example during the most recent ARS, the state may have assigned ARS Response Code 41 to the subunit records (worksites) of a multi-unit UI account. Code 41 indicates that the existing industry code, county, and ownership codes are accurate. Meanwhile the employer stopped providing separate, disaggregated data for this account. The subunits of this multi have to be consolidated or collapsed so the account can be reported as though it were a single unit. If this consolidation involves code changes, then one or more subunits may belong on the CCS and therefore require a CCS-type ARS Response Code. In this case, State staff should update the ARS Response Code field to replace code 41 with code 46. State staff should also make sure the ARS Refile Year is current, and assign Old fields to express the code change. Section 11.5.2 and Section 5.6 explain in detail how to handle an MWR collapse.

In this situation and others, the ARS Response Code that the national office receives on the EQUI file will no longer show what happened in the ARS, but will reflect information gathered from a source other than the ARS. However, generating an accurate and complete CCS is more important, so it takes precedence over the ARS status.

Sometimes the ARS Response Code that came from the ARS indicates that further follow-up is still needed. For example, ARS Response Code 30 (CCS I-error) might remain on several records when the codes are transferred from the ARS Control file to the state system, and to the national office. The national office system will list micro records that have ARS Response Code 30 as well as several other ARS Response codes – codes assigned only in the national office. The national office system will list records with these codes, as described in Section 11.7.4. You should review these records to identify any that may belong on the CCS; then update ARS Response Code and other fields on the state system as needed.

Old fields

Sections 11.2 and 11.3 explain in detail how the Old fields identify code changes. When accurate Old fields are not already present on a record that belongs on the CCS, state staff should update the record to assign them. In particular, if a record was not included in the ARS then its Old fields are likely to be all blank on the state system. If a noneconomic code change is then identified for the record and it belongs on the CCS, the Old fields must be entered. Except for special cases described in Section 11.5 and Chapter 5 (certain MWR breakouts and predecessor/successor situations), the Old fields should be identical to the corresponding classification codes that the record carries in the fourth quarter.

11.4.3 The National Office System Reassigns Some ARS Response Codes

The national office system will reassign ARS Response Codes on its micro file in certain circumstances. The national office system assigns three ARS Response Codes that appear in BLS only, and are never used in state systems. Records receiving these codes will appear on a CCS table (described in Section 11.7.4) and should be reviewed by state staff:

- 33 – The national office assigned, submitted as 46/50 but has CCS I-error on the national office micro file
- 34 – The national office assigned, submitted as 46/50 but does not have a true CCS code change on the national office micro file
- 35 – The national office assigned, submitted with Comment Code 81 and a true code change but not with ARS Response Code 30/46/50.

The national office system also assigns two ARS Response Codes that do appear in state systems. Records receiving these codes are not listed, and no further action is needed:

- 41 – Reviewed, no CCS changes
- 46 – Clean record with CCS updates.

Every change the system makes to an ARS Response Code will be listed on CCS Table 1, the Response Code Change report. This report is described in Section 11.7.1.

Following are more detailed explanations of each of these ARS Response Code reassignments.

ARS Response Code 33 – When micro editing assigns one or more of the CCS-related I-errors to a record, the national office system will change the ARS Response Code to 33. The CCS I-errors are shown in the table in Section 11.4.1. ARS Response Code 33 is similar to code 30 (CCS I-error) in the states. It is assigned only in the national office system and only when the record carried ARS Response Code 46 or 50 and a current ARS Refile Year on the EQUI. Since its ARS Response Code is no longer 46 or 50, the flagged record is excluded from the CCS file in the national office, although it may have been included in the state version.

ARS Response Code 34 – The BLS system will assign ARS Response Code 34 to records that carried ARS Response Code 46 or 50 and a current ARS Refile Year on the EQUI, and that do not have a true CCS code change (as defined in Section 11.2). Code 34 is not assigned if any of the CCS I-errors shown in Section 11.4.1 are present.

As an example, a record may have a code change only from the unclassified industry code 999999, or a change only from a county equivalent code (995-999). If the record carries ARS Response Code 46 or 50 on the state system and the EQUI, the national office system will assign ARS Response Code 34. The record will be listed on the Response Code Change report (shown in Section 11.7.1) and on one of the CCS Tables shown in Section 11.7.4. If the Old fields and first quarter codes are accurate, state staff should change the ARS Response Code on the state system. Usually code 41 will be appropriate.

ARS Response Code 35 – The national office system will assign ARS Response Code 35 to records that do not carry an ARS Response Code for the CCS (46 or 50), but apparently should. The system assigns this code when the record does have a true CCS code change, the ARS Refile Year is current, the comment code for a noneconomic code change (code 81) is present for first or fourth quarter, and an appropriate ARS Response Code is not present. The appropriate ARS Response Codes are 30, 46 or 50. State staff should review any record with ARS Response Code 35 and assign code 46 or 50, if it belongs on the CCS.

ARS Response Code 41 – When an EQUI correction removes any CCS I-errors from a record that previously carried ARS Response Code 30 or 33 and the current ARS Refile Year, the national office system will make an appropriate adjustment. The system determines whether a true CCS code change is present. If there is not, the system assigns code 41. No further action is needed for BLS purposes; however, state staff should review the ARS Response Code on their own state system. To be accurate and consistent, the record should not carry ARS Response Code 46 or 50 on the state file if it does not have a true CCS code change (as defined in Section 11.2). The record should carry ARS Response Code 41 instead.

As an example, a record on the 2020/1 deliverable EQUI may have ARS Response Code 30 and an invalid county code. It may have an industry code change from 999999, or no code change at all. If a 2020/1 EQUI correction fixes the I-error, the national office system will change the code from 30 to 41 on the national office micro file. State staff should assign ARS Response Code 41 on their state system, if it is not already present.

ARS Response Code 46 – As with ARS Response Code 41, the national office system assigns this code when an EQUI correction removes CCS I-errors. When a record with ARS Response Code 30 or 33 and the current ARS Refile Year has a true CCS code change – and has no CCS I-errors – the system assigns code 46. By doing so, the national office system restores the corrected record to the CCS. No further action is needed for the national office files; however, the record also belongs on the state's version of the CCS. State staff should assign ARS Response Code 46 or 50 to the record, if the record does not carry 46 or 50 already.

11.5 Code Changes for Special Cases

Some noneconomic code changes coincide with changes in reporting configuration. In other words, they occur along with a change in the UI Account Number and Reporting Unit Number (UI/RUN) under which an existing establishment is reported.

New breakouts of MWR subunits are one example of reporting changes resulting in noneconomic code changes. A given subunit (worksites) may have been reported as part of a combined reporting unit (typically a record carrying RUN 00000 and MEEI code 4). When the employer agrees to report data separately for each worksite on the MWR, some of the new worksite reporting units (the newly broken out records) may carry different industry codes or area codes than previously reported on the combined RUN 00000. The movement of their data into the correct county/ownership/industry cell should be treated as a noneconomic code change

and reported on the CCS, as described in Section 5.5. For the states that are required to report township codes, the movement of worksite data between townships is also noneconomic and belongs on the CCS.

The collapse of MWR reporters into a single, combined record (with RUN 00000 and MEEI 4 or 6) may also involve the movement of employment and wages between cells. Such movement is also considered a noneconomic code change and belongs on the CCS, as described in Section 5.6. When an establishment changes from one UI account to another, that is, changes from a predecessor to a successor, there also may be code changes that should be treated as noneconomic and that belong on the CCS. These circumstances are described in Section 5.3.

In all these special circumstances, the national office system will create CCS records when it finds the necessary ARS Response Code, ARS Refile Year, and Old fields. If state staff entered the information properly on the ARS Control file, then the state system will pass the necessary data elements to the micro file and no further action is needed. As an alternative, if state staff make appropriate changes to their state system, the EQUI will deliver the proper Old fields, ARS Response Code, and ARS Refile Year to the national office.

In most of these special circumstances, the record that should carry the Response Code and other CCS-related fields will be active in first quarter but not fourth, or will be active in fourth quarter but not first. However, the record must be active in at least one of these two quarters. The national office system will exclude from the CCS any record that is not active (Status Code = 1) in either fourth or first quarter.

11.5.1 Multi-unit Breakouts with Code Changes

The standard systems allow states to handle breakouts and collapses of multi-unit accounts in various ways. However in every case, there should be a record on both state and the national office micro files for every reporting unit (every worksite) that is, will become, or has been active within recent quarters. Some of these worksite records (records with RUN > 00000) may belong on the CCS, as they report the noneconomic movement of their employment and wages between cells.

State staff should first determine which subunits (worksites) have a noneconomic code change. In other words, identify the subunits that will be active in the first quarter and that will report their employment with different industry codes or area codes than were used for those workers in fourth quarter.

Next, use the features of your standard state system (see the system's user documentation) to apply the necessary data elements to your micro file and the EQUI:

1. Assign the fourth quarter values of the earlier record's industry code, county and (for specified states) township to the Old fields of the subunit, where they differ from the new codes. This is also clarified in the examples.

2. Assign the new, correct values of the industry code, county and (for specified states) township to the appropriate first quarter fields of the subunit.
3. Assign an ARS Response Code of 46 or 50 to the subunit, if 46 or 50 is not already present (that is, if 46 or 50 was not already transferred from the ARS Control file).
4. Assign the current ARS Refile Year, if it is not already present on the record.

Several examples follow that explain this further.

Example 1: New MWR Breakout. Consider the case of a multi-unit employer being broken out for the first time in first quarter. All the fourth quarter employment was reported on a record with RUN 00000. Now for the first quarter, the RUN 00000 record becomes a master record (MEEI = 2) while several subunit records become active for the first time. In this example, some of these carry a different county code or industry code (or both) than the RUN 00000 record.

The fourth quarter (2019/4) of the UI account on the state system might appear as below. The employment shown in parentheses would be the actual employment at each of those worksites; however, since the records are not active in fourth quarter, all the employment, wages, and other data are reported and used only on the RUN 00000 record (the only active record).

In this and other examples that follow, the employment is provided to show the relative size of the subunits. For simplicity's sake, the employment appears as completely stable from month to month. The fluctuations that occur in real data would not affect what these examples are intended to show – how the Old fields, ARS Response Code, and ARS Refile Year should be properly constructed to include the records on the CCS.

2019 Fourth Quarter:

RUN	MEEI	Status Code	County	NAICS	Employment
00000	4	1	013	336211	500
00001	3	2 (or 9)	013	336211	0 (or 300)
00002	3	2 (or 9)	009	336211	0 (or 100)
00003	3	2 (or 9)	009	336211	0 (or 50)
00004	5	2 (or 9)	011	336350	0 (or 50)

Note that this account is being reported as a single, since none of the subunit records are active yet. When they become active in the first quarter, records 00002, 00003, and 00004 will report their employment and other data in a different industry code or county than in fourth quarter, that is, they have a different industry code or county code than the previously combined RUN 00000 record. Therefore records 00002, 00003, and 00004 belong on the CCS.

2020 First Quarter:

RUN	MEEI	Status Code	ARS Resp Code	ARS Refile Year	Old Cnty	Qtr 1 Cnty	Old NAICS	Qtr 1 NAICS	Emp
00000	2	1	41	2020		900		336211	500
00001	3	1	41	2020		013		336211	300
<i>00002</i>	3	1	50	2020	<i>013</i>	<i>009</i>		336211	<i>100</i>
<i>00003</i>	3	1	50	2020	<i>013</i>	<i>009</i>		336211	<i>50</i>
<i>00004</i>	5	1	50	2020	<i>013</i>	<i>011</i>	<i>336211</i>	<i>336350</i>	<i>50</i>

In the first quarter, this same UI account is reported with all the subunits as active. The RUN 00000 record is now a master record with MEEI = 2 and county equivalent code = 900 (master). The employment and other data for the macro file (and for most other purposes) will no longer come from the RUN 00000 record because it is a master. The data will now come from the subunit records instead.

The last three records, the records shown in italics, belong on the CCS file. They need ARS Response Code, ARS Refile Year, and Old fields as shown. The national office system will then copy the three records to the CCS.

Note in particular how the Old fields and first quarter codes should be assigned. Record 00002 has a different county code than record 00000, so its correct county code (code 009) is reported in the first quarter county field while the county code under which it was previously reported (code 013) is reported in the Old County field. Record 00004 has different codes both for county and for industry; the first quarter fields carry the correct codes while Old County and Old NAICS carry the previous codes of the account when it was reported as a single.

Record 00003 is handled the same as 00002 where the county code change qualifies both records for the CCS.

In this and all the examples that follow, the code changes shown are from one specific industry code or county code to another. However, there may be cases when the code change is only from an "unclassified" code. Codes changes only from unclassified codes do not belong on the CCS. Suppose, in the example above, the MEEI 4 record (RUN 00000) did not carry county code 013 in fourth quarter, but instead had county 999 (unknown) or 995 (statewide). In that case, subunit records 00002 and 00003 would not belong on the CCS because their only code change is the county code change from 999 to 009. This is a change from unclassified, not a noneconomic code change; therefore, ARS Response Code 50 would be incorrect. The national office system would reassign the ARS Response Code to exclude these two records from the CCS. Record 00004 should still carry ARS Response Code 50 and would still belong on the CCS because it also has an industry code change from one specific code to another.

This discussion focused on the data elements needed for including new subunit records on the CCS. When breaking out subunit records or when making any change in the UI/RUN reporting configuration of existing establishments, state staff should also assign the predecessor or successor ID fields (Predecessor UI Number/Predecessor RUN, or Successor UI

Number/Successor RUN). In the example shown above, all four of the new records should report the Predecessor ID on the first quarter EQUI. The Predecessor UI number will be the same as the regular UI Account Number because all the reporting units remain in the same UI account as before. The Predecessor RUN on all four new records will be 00000, because all the worksites were reported under that RUN in the prior quarter.

Example 2: Further Breakout of a Combined Subunit. Consider the case of a combined subunit (several worksites reported as a combined MEEI 5 record). If the employer will now report the data separately, and if one or more of the new worksites has a different industry code or county than the MEEI 5 record, then it belongs on the CCS.

In this example, assume that this is the same UI account a year later. The employer has offered to report the data separately for the combined subunit record 00004, so this record is being further broken out into new subunit records 00005 and 00006 beginning in the 2021 first quarter. In 2020/4, the new records are not yet active. In 2021/1, record 00004 will become inactive as its employment and other data move to the new records, one of which is in a different county.

2020 Fourth Quarter:

RUN	MEEI	Status Code	County	NAICS	Employment
00000	2	1	900	336211	500
00001	3	1	013	336211	300
00002	3	1	009	336211	100
00003	3	1	009	336211	50
00004	5	1	011	336350	50
00005	3	2 (or 9)	025	336350	0 (or 20)
00006	3	2 (or 9)	011	336350	0 (or 30)

Record 00005 belongs on the 2021 CCS file because of the change in its county code. Its employment and other data will move from county 011 (the code of the MEEI 5 record from which 00005 breaks out) to county 025. When first quarter becomes the current quarter, this UI account should appear on the EQUI with the necessary data:

First Quarter:

RUN	MEEI	Status Code	ARS Resp Code	ARS Refile Year	Old Cnty	Qtr 1 Cnty	Old NAICS	Qtr 1 NAICS	Emp
00000	2	1	41	2020		900		336211	500
00001	3	1	41	2020		013		336211	300
00002	3	1	46	2020		009		336211	100
00003	3	1	46	2020		009		336211	50
00004	5	2	46	2020		011		336350	0
00005	3	1	50	2021	011	025		336350	20
00006	3	1				011		336350	30

The national office system will copy record 00005 to the CCS because it has:

- A true CCS code change in the relationship between the Old fields and the 2021/1 codes,
- A current ARS Refile Year (in this case, 2021), and
- A CCS ARS Response Code (code 50 in this example, although a code 46 has the same effect and would be appropriate if the information came from the ARS).

Note that last year's ARS Response Code and ARS Refile Year remain on other records; however, this does not affect this year's CCS.

In addition to the data elements needed for CCS purposes, state staff should assign Predecessor ID fields (including Predecessor RUN 00004) to the new subunit records. This will link them to the record from which they are breaking out.

Example 3: Breakouts Made in Mid-year. States have the option to break out new subunit records as soon as the employer begins reporting disaggregated data, provided that any code changes are held until first quarter and are included on the CCS. This is described in Section 5.5. For example, an MEEI 4 reporting unit may represent two worksites in different counties. The employer begins providing separate data in second quarter. The combined record (RUN 00000) carried the county code of the primary county. Now that it becomes a master record in second quarter, its county code typically should change to 900, although it may continue to use the same code as before. Meanwhile, both of the new subunit records must remain in the same county (and industry code) in second, third, and fourth quarters as was used for the combined record in first quarter. In this example, the smaller subunit record (RUN 00002) is reported in county 005 even though the worksite is really located in county 007.

2019 First Quarter:

RUN	MEEI	Status Code	County	NAICS	Emp
00000	4	1	005	452319	100

2019 Second, Third, and Fourth Quarters:

RUN	MEEI	Status Code	County	NAICS	Emp
00000	2	1	900	452319	100
00001	3	1	005	452319	65
00002	3	1	005	452319	35

The county code for RUN 00002 should be corrected beginning in first quarter, and it belongs on the CCS. When first quarter becomes the current quarter, the UI account should be updated to carry the necessary data on the EQUI file:

2020 First Quarter:

RUN	MEEI	Status Code	ARS Resp Code	ARS Refile Year	Old Cnty	Qtr 1 Cnty	Old NAICS	Qtr 1 NAICS	Emp
00000	2	1				900		452319	100
00001	3	1				005		452319	65
00002	3	1	50	2020	005	007		452319	35

As in earlier examples, the choice of ARS Response Code (46 or 50) should be based on the source of the information. If the information for the code change originated in the refiling survey, assign 46; otherwise assign 50. As before, the records that do not belong on the CCS may or may not already carry an ARS Response Code and ARS Refile Year.

Also as in the earlier examples, the state should include predecessor information when the new records are broken out. In this case, the predecessor fields (including Predecessor RUN 00000) should appear on the new records in 2019/2, since that is the quarter during which they become active. While BLS requires that noneconomic code changes be held until first quarter, the predecessor or successor fields should be provided right away. They should appear on the EQUI file for the quarter when the reporting change takes place.

Example 4: Professional Employer Organization (PEO) Breakouts in Mid-year. As mentioned in Section 15.3, many businesses, small businesses in particular, enter into a co-employer relationship with PEOs. In most cases, only a small portion of the client business staff (typically executives and managers) will remain on the payroll of the original (client) firm. The workers are normally transferred to the PEO. Client businesses find it financially advantageous to transfer their workers to PEOs since this arrangement can relieve the clients of human resource and administrative work.

Under normal circumstances, if a breakout occurs in a PEO in mid-year (i.e., other than first quarter) and the breakout causes a change from one classified industry or area to another classified industry and/or area due to non-economic events, the code change(s) should be held by the state until the next first quarter and reported on the Code Change Supplement.

However, for larger PEOs, handling and reporting breakouts, births, deaths, out-of-business units, or other reporting changes can become difficult and very time consuming for state QCEW staff. Clients enter into and out of relationships with PEOs regularly. It is advised that, in these particular cases the state contact their appropriate regional office for guidance and/or assistance in handling these more difficult PEO cases.

11.5.2 Multi-unit Collapses with Code Changes

State staff should first determine which subunits (worksites) have a noneconomic code change. In other words, identify the old subunits that will become inactive in the first quarter and whose

employment will now be reported in a different industry code or county than was used for those workers in fourth quarter.

Next, use the features of your standard state system (see documentation for your state) to apply the necessary changes to your micro file and the EQUI:

1. Allow the record for the old subunit to remain on the state system, even though it becomes inactive. Do not mark it for deletion since that effectively removes all quarters of data (including active quarters) from the state and the national office micro files and prevents the record from being copied to the CCS. The record must remain until all CCS processing for the year is completed, and so its historical data will be included in subsequent aggregations.
2. Assign the new values of the industry code, ownership, county, and (where appropriate) township to the inactive first quarter of the old subunit record. Make sure that all the first quarter codes are present, whether or not they differ from the fourth quarter.
3. Assign the old values of industry code, county or (where appropriate) township to the Old fields of the subunit record, where they differ from the first quarter values.
4. Assign an ARS Response Code of 46 or 50 to the subunit, if 46 or 50 is not already present (that is, if 46 or 50 was not already transferred from the ARS Control file).
5. Assign the current ARS Refile Year, if it is not already present on the record.

Examples follow that will explain this further.

Example 1: Collapse of an MWR Reporter to a Single. Consider the case of a multi-unit employer being collapsed into a single-unit record beginning with first quarter. The new single, the record with RUN 00000, was formerly a master record with MEEI = 2. Now its MEEI will typically change to 4 or 6, and it will begin to carry all the employment and wage data. The industry code and county codes should be assigned as described in Section 5.6. Any of the subunits whose industry code or county codes were different than the new MEEI 4 or 6 record belongs on the CCS.

The fourth quarter (2019/4) of the UI account on the State system might appear as follows.

2019 Fourth Quarter:

RUN	MEEI	Status Code	County	NAICS	Own	Employment
00000	2	1	900	561599	5	150
00001	3	1	013	561599	5	85
00002	3	1	007	561599	5	40
00003	3	1	009	541990	5	25

This fourth quarter multi has more than one county and more than one industry code. Collapsing it into a first quarter single unit means in this case that the county and industry codes of the largest former subunit become the codes of the RUN 00000 record (whose MEEI code changes from 2 to 4). The employment of the two smaller subunits will change county, industry code, or both; therefore they belong on the CCS. On the first quarter EQUI, the account should be reported as follows:

2020 First Quarter:

RUN	MEEI	Status Code	ARS Resp Code	ARS Refile Year	Old Cnty	Qtr 1 Cnty	Old NAICS	Qtr 1 NAICS	Old Own	Qtr 1 Own	Emp
00000	4	1	41	2020		013		561599		5	150
00001	3	2	41	2020		013		561599		5	0
00002	3	2	46	2020	007	013		561599		5	0
00003	3	2	46	2020	009	013	541990	561599		5	0

Even though RUNs 00002 and 00003 are inactive (Status Code = 2), they will be placed on the CCS because of their ARS Response Code, ARS Refile Year, and Old fields, and because their fourth quarter was active (Status Code = 1).

The ARS Response Codes shown here are 46 for the units belonging on the CCS, and 41 for the others. In this example, ARS Response Codes are assigned as though information came from the FY 2020 ARS. (In fact all of the information shown might have been passed from the ARS Control file to the state system).

If the information came from sources other than the ARS, ARS Response Code 50 (code change from non-ARS source) would be more appropriate for RUNs 00002 and 00003. Meanwhile state staff would not assign an ARS Response Code or an ARS Refile Year to RUNs 00000 and 00001, but instead leave those fields blank.

As in the earlier examples, the state should provide predecessor or successor information, even though it does not directly affect CCS processing. In this case, BLS will receive the most beneficial linking information if all the collapsing subunits (including 00001) contain Successor ID fields (including Successor RUN 00000) on the 2019/4 EQUI.

Example 2: Collapse of Several Worksites into a Combined Worksite. There may be occasions when an employer will no longer report the data for some of the worksites separately, so some records should be collapsed by terminating (inactivating) them and creating a new, combined record with MEEI 5. This collapse may cause some employment to be reported in a different industry or county, so the inactive subunit(s) in question belong on the CCS. Consider the following example.

The fourth quarter (2019/4) of the UI account on the state system might appear as follows.

2019 Fourth Quarter:

RUN	MEEI	Status Code	County	Own	NAICS	Emp
00000	2	1	900	5	562920	90
00001	3	1	015	5	562920	35
00002	3	1	015	5	221320	25
00003	3	1	009	5	562920	30

Suppose records 00001 and 00002 can no longer be reported separately. A new record should be created in 2020/1 with the next available RUN (00004) and with MEEI 5. In this case it will carry the industry code and county of the larger inactivated subunit – NAICS 562920 and county 015. The smaller inactivated subunit, 00002, belongs on the CCS because its employment will now be reported in a different industry code. The record should be reported as follows on the state system and the EQUI file in first quarter:

2020 First Quarter:

RUN	MEEI	Status Code	ARS Resp Code	ARS Refile Year	Old Cnty	Qtr 1 Cnty	Old NAICS	Qtr 1 NAICS	Old Own	Qtr 1 Own	Emp
00000	2	1				900		562920		5	90
00001	3	2				015		562920		5	0
00002	3	2	50	2020		015	221320	562920		5	0
00003	3	1				009		562920		5	30
00004	5	1				015		562920		5	60

As in the previous example, RUN 00002 will be placed on the CCS even though it is inactive in first quarter.

As in all the earlier examples, BLS needs predecessor or successor information. This will identify the establishments as continuous, in spite of the change to their UI/RUN reporting configuration. In this case the linkage will be clear if you assign the Successor ID (including Successor RUN 00004) to both collapsing records (records 00001 and 00002) in time for the 2019/4 EQUI.

11.5.3 Predecessors and Successors with Code Changes

Section 5.3 describes the successor situations that should be reflected on the CCS. Use the following procedures to place successors with noneconomic code changes on the CCS:

State staff should first identify the record that will report the noneconomic code change. This is discussed further below. Then use the features of your standard state system to apply the necessary data elements to your state system and the EQUI file:

1. Assign the new, correct values of the industry code, ownership, county and (for specified states) township to the first quarter fields of the record that will report the code change (typically the successor).
2. Assign the fourth quarter values of the industry code, ownership, county and (for specified states) township to the Old fields of the record, where they differ from the first quarter codes.
3. Assign an ARS Response Code of 46 or 50 to the record, if 46 or 50 is not already present (that is, if 46 or 50 was not already transferred from the ARS Control file).
4. Assign the current ARS Refile Year, if it is not already present on the record.

In addition to assigning the CCS-related data elements listed above, state staff should also update the records in question with the predecessor or successor ID fields. (The successor record should carry the Predecessor UI Account Number and Predecessor RUN; or the predecessor record should carry the Successor UI Account Number and Successor RUN.) The proper use of these fields is explained in Chapter 5 and Appendix B.

Example 1: A single unit that changes UI accounts. Suppose a store was sold to a new owner in June 2019, and it begins operating under a new UI Account Number. An ARS response shows that the establishment is not a warehouse club and supercenter (NAICS 452311) as it has been coded for several years, but a department store (NAICS 452210). If the employment is sufficiently large (greater than 25 in the months preceding and following the change) then the industry code change should be applied to the successor record, but not until the following first quarter. The successor record belongs on the CCS. Update the record if necessary so it will appear as follows on the state system and the EQUI file in first quarter:

2020 First Quarter:

RUN	MEEI	Status Code	ARS Resp Code	ARS Refile Year	Old NAICS	Qtr 1 NAICS
00000	1	1	46	2020	452311	452210

As with any continuous record, assigning the ARS Response Code, ARS Refile Year, and appropriate Old field(s) is sufficient to place the record on the CCS in the national office. The procedure would be the same if the store in question is a subunit (worksites) of a multi-unit account, or if it were formerly a single unit and became a subunit record within a different UI account. Section 5.4 describes this further.

Suppose the transfer of ownership (and the transition to a new UI Account Number) had happened at the end of December 2019 or during the first quarter of 2020. The successor record would not exist as an active record until first quarter. Nevertheless, updating the successor with an appropriate ARS Response Code, ARS Refile Year, and Old field(s) would place the successor record onto the CCS.

As explained in the next section, the employment and wage data on the CCS might then be incomplete, since part of these data would come from the successor and be included on the CCS, while part would reside on the predecessor and be omitted. In other words, the four months of employment (December through March) and both quarters of total wages (fourth and first quarter) would be split between the predecessor and successor records. If the employment in question is sufficiently large and depending on when the transfer occurred, the state can take the necessary steps to put the predecessor record onto the CCS rather than the successor. You may also put both the predecessor and successor records onto the CCS.

To put a predecessor record onto the CCS, assign the same ARS Response Code, ARS Refile Year, Old fields, and first quarter codes as you would use for the successor record. As in the case of a collapsed subunit with code changes, the first quarter codes on a predecessor should show where the employment is being reported in first quarter. The Old fields show where the employment was reported in fourth quarter. In addition, the record must be active during at least one of the quarters in question (first or fourth quarter).

Note that partial successor situations, in which part of one establishment's employment transfers to another establishment, are not normally treated as noneconomic code changes. They do not belong on the CCS. This is addressed in Section 2.3.2.

11.5.4 How the System Handles Missing Employment or Wages

The CCS and Summary of Differences files include employment data for four months: December (month 3 of the fourth quarter) plus all three months of first quarter. They also include total wages for both fourth and first quarter. In some of the circumstances covered in the preceding sections, the four months of employment and two quarters of wages do not reside entirely on one record (one UI/RUN). Yet in nearly all cases, only one record will be copied to the CCS. Therefore part of the data for the establishment may be omitted from the CCS.

This section describes how the system treats missing employment and wage data on records that otherwise qualify for the CCS. In brief, if all other conditions are met but economic data fields are missing, then the system will still create the CCS record. If economic data are missing in a configuration consistent with a breakout, the national office system copies first quarter data to the fourth quarter on the CCS record. For a probable collapse, the system copies fourth quarter data to the CCS first quarter. For other situations including a probable predecessor or successor, the system zero-fills the missing data fields.

This process may sometimes assign imprecise or inaccurate data to the CCS and Summary of Differences. However, the remedies for this are very limited. Employment and wage data on the CCS and Summary of Differences are copied from the state system and the systems (in the national office and the states) do not offer any capability to change CCS data separately from the corresponding data fields on the state system. These economic data fields on the state system must be as accurate as possible because they appear (in aggregated form) on the macro file and in various other uses.

Probable Breakouts

December employment and fourth quarter wages cannot be copied to the CCS record when they are not present on the state system record. When a CCS record is created for a subunit that has been broken out for the first time in first quarter, the real December employment and fourth quarter wages may reside only on a different record, and only as part of an aggregation. In other words, the fourth quarter data may exist only as some portion of the data on the RUN 00000 record, which was reported as a single (typically with MEEI 4). The national office system will attempt to estimate (copy) data between quarters so the CCS will not understate the movement of fourth quarter data.

The national office system will estimate CCS data for a probable breakout situation when all these conditions occur:

1. The RUN of the record that qualifies for the CCS is greater than 00000,
2. The fourth quarter total wages and December employment of the record are missing (data = 0 and indicators = M), and
3. For the three months of first quarter employment and for first quarter total wages, none of the fields are missing.

When these conditions occur, the system creates a CCS record with estimated December employment and fourth quarter wages. The estimation simply consists of copying January (month 1) employment to December employment, and copying first quarter wages to fourth quarter wages.

Probable Collapses

The national office system will estimate CCS data for a probable collapse when all these conditions occur:

1. The RUN of the record that qualifies for the CCS is greater than 00000,
2. The first quarter total wages and all three months of first quarter employment of the record are missing (data = 0 and indicators = M), and
3. Neither December employment nor fourth quarter wages are missing.

When these conditions occur, the system creates a CCS record with estimated January, February, and March employment as well as estimated first quarter wages. The estimation consists of copying December employment to January, February, and March; and copying fourth quarter wages to first quarter wages.

As in the case of a new breakout, subunit records that are collapsed in first quarter typically do not carry their real first quarter data – these data are now part of the aggregation on an MEEI 4 record. The system therefore estimates (copies) data on the CCS record from the fourth quarter to the first quarter.

Probable Successors or Predecessors and Other Cases

The national office system will zero-fill missing data on the CCS record when missing data on the state system are present in any configuration other than the ones described above – for a probable breakout or a probable collapse.

The following configurations suggest a probable predecessor or successor:

Case #	RUN	Dec Emp Missing?	Q4 Wages Missing?	Jan Emp Missing?	Feb Emp Missing?	Mar Emp Missing?	Q1 Wages Missing?
1	00000			yes	yes	yes	yes
2	00000	yes	yes				
3	(any)	yes	yes	yes			
4	(any)	yes	yes	yes	yes		
5	(any)				yes	yes	
6	(any)					yes	

Cases 1 and 2 are identical to the conditions for probable breakout subunits and probable collapse subunits, respectively, except that the RUN is zero-filled. Subunits cannot have RUN 00000. Therefore cases 1 and 2 are more consistent with a single-unit successor and predecessor, respectively. Case 1 might be a predecessor that terminates in December, while case 2 might be a successor that begins operations in January.

Cases 3 and 4 are consistent with successor records. The case 3 record apparently starts up in February, while case 4 seems to start in March. Cases 5 and 6 are consistent with predecessors that terminate after January and February, respectively.

There are many possible configurations of missing employment and wage fields other than the six described above for probable breakouts, collapses, successors, and predecessors. These other configurations seem questionable, but suggest unsuccessful data imputation (estimation) in the state rather than situations that affect the CCS. For example, fourth quarter wages may be missing (Total Wage Indicator = M) because insufficient wage data were present in earlier quarters for the state system to impute fourth quarter. (Successful imputation would change the indicator from M to another value, typically E.)

These are just a few examples of questionable situations:

Case #	RUN	Dec Emp Missing?	Q4 Wages Missing?	Jan Emp Missing?	Feb Emp Missing?	Mar Emp Missing?	Q1 Wages Missing?
1	(any)		yes				
2	(any)		yes	yes			
3	(any)						yes
4	(any)			yes	yes		
5	(any)				yes		

When any of these questionable cases occur, the national office system will zero-fill the data field on the CCS and list the record for review on a report. This report (CCS Table 8) is titled CCS Records with Questionable Missing Employment/Wages and is shown in [Section 11.7.4](#).

11.5.5 When Out-of-Business Units Have No Successor

The sections above describe special cases that belong on the CCS when there is not a stable, active record present in both fourth quarter and first quarter. In these cases (breakouts, collapsed, and successors) a noneconomic code change occurs when there is an active, continuous establishment in some sense, even though the data are not continuously reported under the same UI Account Number and RUN.

For some records a noneconomic code change is identified, but the establishment does not remain active because the unit goes out of business. The ARS (or some other source) may identify a correction to an establishment's industry, area, or ownership codes; however, before the correct code can be implemented in first quarter, the establishment permanently ceases operations. **Such records do not belong on the Code Change Supplement.** The CCS should not be used to retroactively identify and correct inaccurate codes for business "deaths" that occur before the first quarter.

If a reporting unit goes out of business permanently and without a successor, the state should **not** assign the ARS Response Code, ARS Refile Year, and Old fields that would put it onto the CCS. ARS Response Code 64 (Out of business) is appropriate for such cases; codes 46 and 50 are not. In addition, for these cases, state staff should verify that the reporting unit has been terminated, or take the necessary actions to do so. An End of Liability Date should be assigned to the state system (and EQUI) record, with the Status Code changing to 2 (inactive) for the quarter following the last quarter with reported employment.

11.6 Generating the Summary of Differences File for the Integrated Edit

The Summary of Differences file provides the CCS employment and wage data at an aggregated level. For all affected county/ownership/industry cells, this file shows how much data enter and leave due to CCS code changes. The Summary of Differences file contains one record for each county/ownership/industry cell.

The data fields are as follows:

- December Employment
- Fourth Quarter Wages
- January Employment
- February Employment
- March Employment
- First Quarter Wages
- Number of Records (reporting units)

The national office system generates the Summary of Differences file from the CCS file, so they are consistent and use the same data. The only exception occurs for states that are required to use township codes (New Jersey and the New England states). If the CCS file for one of these states includes records with a change only to the township code (i.e., no changes to county, ownership, or industry), such records are excluded from the Summary of Differences. The Summary of Differences shows changes only to county, ownership, or industry.

The national office system uses two important steps when generating the Summary of Differences file:

1. CCS records are sorted by the Old fields (Old County, Old Ownership, and Old NAICS). Then the data elements listed above are summed for each county/ownership/industry cell. This becomes the data “from” each cell, that is, the data that are leaving the cell due to noneconomic code changes.
2. CCS records are then sorted by current fields (Current County, Current Ownership, and Current NAICS), and then the data elements listed above are summed for each cell. A “current” field is the New field if present; otherwise it is the Old field. For example, if a record has New NAICS as its only New field, then the current fields consist of Old County, Old Ownership, and New NAICS. Note that the current fields on a CCS record match the first quarter codes on the corresponding record. This data becomes the data “to” each cell, that is, the data that are entering the cell due to noneconomic code changes.

The national office system also generates a Summary of Differences report, shown in Section 11.7.5. For each cell, the report shows the data leaving (“from”), the data entering (“to”), and the net change (calculated as data “from” minus data “to”). The net change is used in the macro portion of the integrated edit, in a process called code change integration.

Code change integration uses Summary of Differences data in a temporary editing adjustment to the macro data. Its purpose is to prevent macro flags that would occur due to noneconomic code changes. Code change integration temporarily restores data that enter or leave macro cells as a result of noneconomic code changes reported on the CCS. Code change integration is used in the following macro edits:

Edit Code	Edit Message
091	Employment Change Greatly Exceeds Test Parameters
092	AQW Change is Significantly > Parm and Exceeds Twice the Quartile AQW Range
126	Employment Change Exceeds Test Parameters
127	AQW Change > Parm and Exceeds Twice the Quartile AQW Range
134	Number of Establishments out of Range

In the national office system, if Summary of Differences data exist for a macro cell but that cell still fails one of the macro edits, then the edit listing displays the Summary of Differences data. This appears on Table 9A, the Integrated Macro Edit listing. Code change integration is more fully explained in Section 10.3.1.

The Summary of Differences file includes December employment and fourth quarter wages even though these data are not used for code change integration. This is because CES and other data users still need December employment and fourth quarter wages for noneconomic code changes, aggregated to the macro cell level.

11.7 Printed Output from CCS Processing

The national office system generates the following listings during normal EQUI processing, beginning in first quarter and continuing through the end of second quarter. These reports are described in the sections immediately following.

- CCS Table 1: Response Code Change
- CCS Table 1A: Selected Records with Sector Level Code Change
- CCS Table 1B: Selected Records with Code Changes Within the Sector or/and Locality Change or/and Ownership Change
- CCS Table 2: CCS Creation Counts Report
- CCS Table 3: Records Excluded Due to Nonnumeric Employment/Wages or Missing Classification Codes
- CCS Table 5: Records with Response Code 30, 33, 34, or 35
- CCS Table 6: Records Excluded Due to Missing Code Change
- CCS Table 7: ES-202 Code Change Summary of Differences
- CCS Table 7A: Changes in Code Change Summary of Differences

The national office system can also generate three additional reports upon request. The first report is described in Section 11.8:

- CCS Master List
- CCS Table 4 – CCS Zero Employment and Wages Reported
- CCS Table 8 – CCS Records with Questionable Missing Employment/Wages

11.7.1 CCS Table 1: Response Code Change

The listing of (ARS) Response Code changes displays the identifying fields of EQUI records whose (ARS) Response Codes were changed by the national office system in the current edit job. The listing also shows the codes for each record, before and after they changed. It concludes with a count for the number of records whose codes were changed (and listed). ARS Response Code reassignment is described in Section 11.4.3. A sample page appears as EXHIBIT 11A.

EXHIBIT 11A Response Code Change Report

UI NUMBER	RUN	STATE ASSIGNED RESPONSE CODE	BLS ASSIGNED RESPONSE CODE
0000400403	00030	50	34
0000400403	00031	50	34
0000400403	00036	50	34
5000400404	00035	50	34
5000400404	00074	50	33
2000300313	00002	46	34
2000300313	00003	46	34
2000100118	00000	46	34
6000300314	00000	46	34
6000400416	00011	46	34
6000400416	00018	46	34
7000500518	00006	46	34
0000300328	00003	46	34
5000504568	00000	50	34
4000604658	00000	46	33
7000804857	00000	50	34
7000404459	00000	50	34
9000904964	00000	50	34
6000604666	00004	50	35
6000604666	00005	50	35
9000404466	00000	50	33
1000604661	00000	50	34
9000604661	00000	50	34

11.7.2 CCS Tables 1A and 1B: Code Changes for Large Records

The Selected Records with Sector Level Code Change report (CCS Table 1A) lists CCS records with employment above a parameter and with an industry code change between industry sectors. The system compares December employment to the parm unless December employment is zero. In that case, the system compares January employment to the parm.

Selected Records with Code Changes within the Sector (CCS Table 1B) lists CCS records with employment above a parameter and with a code change within an industry sector. This type of code change can include a change between industry codes in the same sector. It can also include changes to ownership, county, or township. As long as the CCS record does not change industry codes between sectors, it will appear on 1B rather than 1A. As with CCS Table 1A, the system compares December employment to the parm unless December employment is zero. In that case, the system compares January employment to the parm.

These two listings should be used to verify and correct, if necessary, the code changes. The national office may follow up with specific questions concerning records listed on these reports. The parms for these two reports, which determine the employment size of the records to be listed, are included on the EQUI header record. This gives the national office the opportunity to generate the reports using the same employment thresholds used by the state. BLS's default values for these parameters are provided in EXHIBIT 11B. Samples of CCS Tables 1A and 1B are provided as EXHIBITS 11C and 11D, respectively.

EXHIBIT 11B Parameters for CCS Edit Tables 1A and 1B

The following are the State-specific parameter defaults the national office uses to generate CCS Tables 1A and 1B.

State	Sector Level (1A)	Within Sector (1B)	State	Sector Level (1A)	Within Sector (1B)	State	Sector Level (1A)	Within Sector (1B)
Boston/New York region			Atlanta region			Dallas/Kansas City region		
CT	225	400	AL	175	275	AR	100	200
ME	90	175	FL	500	950	CO	225	375
MA	475	875	GA	300	475	KS	150	225
NH	90	175	KY	200	350	LA	200	325
NY	500	1,000	MS	90	175	MO	250	450
PR	50	50	NC	250	425	MT	50	90
RI	90	175	SC	175	250	NM	90	175
VT	50	90	TN	225	425	OK	175	250
VI	50	50	Chicago region			TX	500	1,000
Philadelphia region			IL	500	1,000	UT	100	200
DE	60	125	IN	225	375	WY	50	50
DC	200	350	IA	175	225	San Francisco region		
MD	350	600	MI	450	800	AK	50	60
NJ	450	900	MN	250	450	AZ	225	425
PA	500	1,000	NE	125	200	CA	500	1,000
VA	375	600	ND	50	90	HI	100	225
WV	80	150	OH	500	950	ID	50	80
			SD	50	90	NV	175	450
			WI	250	475	OR	175	250
						WA	225	375

EXHIBIT 11C Listing 1A

DATE: 07/25/2005		TIME: 06:07:08 PM		(STATE)										PAGE 1						
INITIAL RUN 2005/1		SELECTED RECORDS WITH SECTOR LEVEL CODE CHANGE (CCS TABLE-1A)										**CONFIDENTIAL DATA**								
BUREAU OF LABOR STATISTICS - EQUI PROCESSING																				
PARAMETERS:																				
MIN-EMP-TO-LIST-CCS-RECORD-WITH-SEC-CHANGE = 500																				
UI	ACCOUNT	RUN	EI	NUMBER	TRADE/LEGAL NAME	A	U	OLD	OLD	OLD	OLD	NEW	NEW	NEW	NEW	DEC	4TH QTR	JAN	1ST QTR	ADM
						X	NAICS	OWN	CTY	TWN	NAICS	OWN	CTY	TWN	EMPL	EMPL	EMPL	EMPL	VER	
0000034650	00000	541830748		MOONS TAVERN	5	565412	5	047			701112				73	1709878	73	1669823	511	
0000232431	00012	412300010		PINPOINT BALLOONS INC	0	445947	5	083			411915	085			103	3711214	98	4276897	511	
0000264458	00076	545500000		STARES & BARES	5	515211	5	085			729914				54	925445	48	829254	511	
0000423341	00000	769915696		FOOD FOR THAT	5	715411	5	085			738978	037			55	724524	55	648754	511	
0000425731	00002	871745273		SERENITY MARKERS	0	445099	5	075			571915	081			126	893245	129	932458	511	
0000536576	00004	760053657		FORMANS COUNTRY FOUNDATI	5	567389	5	037			386174	073			96	1922343	86	2124386	511	
0000616575	00006	468600020		BABAR SQUIRE CONSTRUCTIO	5	496512	5	037			593202				248	2852665	209	2266586	511	
0000666078	00002	873252522		NATIONAL PRONOUNCEMENT	1	445812	5	065	000		799995				115	1913840	0	276	511	
0000666078	00005	873252522		NATIONAL PRONOUNCEMENT	5	445812	5	065	000		799995				61	758429	0	1669	511	
0000786052	00000	873842488		ASSOCIATED SOULS & GHOUL	5	455357	5	065	000		782242				116	392385	113	498188	511	
0000789051	00000	876946096		PUN SERVICE EVENTS INC	5	475947	5	065	000		735935				55	925450	44	718193	511	
0000883076	00001	874252522		ODD SERVICES	1	784141	5	065	000		593274				83	1499482	78	901275	511	
0000883076	00002	874252522		ODD SERVICES	1	784141	5	065	000		593245				292	5454933	0	138	511	
0000883076	00007	874252522		ODD SERVICES	1	784141	5	065	000		593296				0	0	103	2303105	511	
0000883076	00008	874252522		ODD SERVICES	1	784141	5	065	000		593214				0	0	185	2709828	511	
*** CONFIDENTIAL DATA *** FOR STATISTICAL USE BY AUTHORIZED PERSONNEL ONLY, DESTROY ACCORDING TO RECORDS RETENTION SCHEDULE.																				

EXHIBIT 11D Listing 1B

DATE: 07/25/2005		TIME: 06:07:08 PM		(STATE)										PAGE 1			
INITIAL RUN 2005/1		SELECTED RECORDS WITH CODE CHANGE WITHIN THE SECTOR OR/AND LOCALITY CHANGE OR/AND OWNERSHIP CHANGE (CCS TABLE-1B)										**CONFIDENTIAL DATA**					
BUREAU OF LABOR STATISTICS - EQUI PROCESSING																	
PARAMETERS:																	
MIN-EMP-TO-LIST-CCS-RECORD-FOR-REPORT 1B = 1000																	
UI ACCOUNT	RUN	EI NUMBER	TRADE/LEGAL NAME	A	U	OLD	OLD	OLD	OLD	NEW	NEW	NEW	NEW	DEC	4TH QTR	1ST QTR	ADM
				X	NAICS	OWN	CTY	TWN	NAICS	OWN	CTY	TWN	EMPL	WAGES	EMPL	WAGES	VER
														(\$1000S)	(\$1000S)		
0000100432	00000	410389000	TWEEDLEDUM LANE MARKET	0	209911	5	057		220632					104	2112305	101	2012371 511
0000200243	00012	410230000	WATTERFORD AND LESTER	0	367922	5	083					085	223	33711214	280	24676897 511	
0000213227	00044	420105000	STARKEY INC	5	421066	5	037		423165				212	2276859	210	2127598 511	
0000300434	00000	893656570	L & L LANDSCAPE	0	509953	5	085		508732			037	144	2324524	154	2394527 511	
0000500473	00006	416824450	MOLE & SON LANDSCAPERS	0	509978	5	075		503378			081	226	5593245	226	593245 511	
0000508566	00000	451603540	FAMISHED SHOE WARHOUSE	0	514954	5	081					037	124	3289072	133	2928907 511	
0000509556	00002	745656744	BOBS BAR & GRILL	0	541198	5	037		544115			071	119	1796786	117	1742389 511	
0000600065	00000	420066557	MICKEYS TAVERN	0	581232	5	047		581389				573	1709878	573	1627822 511	
0000604574	00000	987766447	MIRAKLE MARKETS	0	602145	5	059		602265				199	2724597	187	2324091 511	
0000630054	00000	895765435	HOSS SHOES	0	621148	5	037		622132				151	4183490	166	4834904 511	
0000660657	00006	749686099	BAB SQUARE CONSTRUCTION	5	651296	5	037		653114				308	1452665	302	1465745 511	
00006663245	00016	450455000	GOSTARE	5	651212	5	085		651320				138	6925445	130	6255483 511	
0000700534	00000	410078556	FASHION STOREY MARKETING	0	738936	5	037					073	286	9223283	280	9323269 511	
0000700567	00003	893122430	INFORMANTS COUNTRY FOUND	0	738984	5	037					073	116	1922343	131	2122337 511	

*** CONFIDENTIAL DATA *** FOR STATISTICAL USE BY AUTHORIZED PERSONNEL ONLY, DESTROY ACCORDING TO RECORDS RETENTION SCHEDULE.

11.7.3 CCS Table 2: CCS Creation Counts Report

This report is generated each time the CCS file is created. A downloadable file is also produced for internal office use that is utilized in generating edit counts. The report may be especially helpful in identifying the level of records excluded from the CCS file due to problems, such as containing a CCS-related I-error or not having the expected code change. It displays the following counts:

```

NUMBER OF RECORDS ON THE MICRO FILE
NUMBER OF CURRENT REFILE RECORDS ON THE MICRO FILE
NUMBER OF RECORDS PUT ONTO THE CCS FILE
NUMBER OF CCS RECORDS WITH ZERO EMPLOYMENT/WAGES
NUMBER OF CCS RECORDS WITH QUESTIONABLE MISSING EMPLOYMENT/WAGES

NUMBER OF MICRO FILE RECORDS EXCLUDED FROM THE CCS FILE:
- WITH RESPONSE CODE 46/50 AND NO CCS CODE CHANGE
- WITH NON-NUMERIC EMPLOYMENT/WAGES OR MISSING CODES
- WITH RESPONSE CODES FOR I-ERRORS (30 & 33) OR OTHER
  PROBLEMS (34 & 35)

```

Additional counts include:

```

TOTAL NUMBER OF CCS RECORDS WITH:
NEW NAICS
NEW OWNERSHIP
NEW COUNTIES/NAICS CHANGES ONLY
OWNERSHIP CHANGES ONLY
LOCATION CHANGES ONLY
NAICS AND OWNERSHIP CHANGES
NAICS AND LOCATION CHANGES
OWNERSHIP AND LOCATION CHANGES
NAICS, OWNERSHIP AND LOCATION CHANGES

```

The second count, number of current refile records on the state system, is a count of records with the current year in the ARS Refile Year field. The fourth count, CCS records with zero employment and wages, refers to the records listed on the CCS Zero Employment and Wages Report. This report is described in the next section. The fifth count, CCS records with questionable missing employment/wages, refers to the records listed on CCS Table 8 and is described in the next section as well as Section 11.5.4.

The sixth, seventh, and eighth counts refer to records that were excluded from the CCS; however, their ARS Response Code or other conditions suggest that these records were intended for the CCS and should be reviewed. The records counted here are displayed on CCS Tables 6, 3, and 5, respectively. They are also described in the next section.

The final ten counts show the types of code changes present on the CCS file. The first group shows how many code changes altogether are present for that type of code change. For example, the total number of CCS records with a New NAICS shows the number of CCS records with any NAICS industry code change. For New England states and New Jersey only, a count of records with a township code change is listed. The second group shows more specifically how many industry code changes (for example) occur by themselves and how many occur in the various combinations with other types of code changes.

11.7.4 Missing Code Changes, Problem Response Codes, and Other Reports

The national office system generates five reports using similar formats:

- CCS Table 3: Records Excluded Due to Nonnumeric Employment/Wages or Missing Classification Codes
- CCS Table 4: CCS Zero Employment and Wages Report (generated on request only)
- CCS Table 5: Records with Response Code 30, 33, 34, or 35
- CCS Table 6: Records Excluded Due to Missing Code Change
- CCS Table 8: CCS Records with Questionable Missing Employment/Wages (generated on request only)

CCS Tables 4 and 8 (generated on request only) list records that are included on the CCS file but have characteristics calling for review. The other three tables list records from the national office micro file that may belong on the CCS but were excluded. Table 5, the report of Records with Response Code 30, 33, 34, or 35, is provided as EXHIBIT 11E to illustrate the format shared by this group of reports.

CCS Table 3: Records Excluded Due to Nonnumeric Employment/Wages or Missing Classification Codes

This listing, CCS Table 3, shows records that otherwise qualified for the CCS but were excluded for certain reasons. Specifically, these are records with a missing (blank) first quarter classification code (industry code, ownership, county, or (for New England states and New Jersey) township). This report also shows records excluded due to nonnumeric entries in one of the four monthly employment fields (December through March) or the two total wages fields (fourth quarter or first quarter). State staff should review records listed on this report to identify and correct the missing or nonnumeric data elements on the state system. In addition, any records on this report should be reviewed to see whether they belong on the CCS. If so, the appropriate correction should be made.

CCS Table 4: CCS Zero Employment and Wages Report

This listing, generated on request, shows CCS records with zero data in either the fourth quarter, the first quarter, or both. A CCS record will be listed if any of these conditions occurs:

1. Both December employment and fourth quarter wages are zero.
2. All three months of first quarter employment as well as first quarter wages are zero.
3. All four months of employment (December through March) and both quarters of wages (fourth and first) are zero.

The records are listed for reference. These situations may be legitimate, and usually do not require correction.

CCS Table 5: Records with Response Code 30, 33, 34, or 35

This listing, CCS Table 5, shows records that have a current ARS Refile Year and that have one of the following ARS Response Codes:

- 30 – CCS I-error
- 33 – The national office assigned, submitted as 46/50 but has CCS I-error on the national office micro file
- 34 – The national office assigned, submitted as 46/50 but doesn't have a true CCS code change on the national office micro file
- 35 – The national office assigned, submitted with Comment code 81 and a true code change but not with an ARS Response Code of 30/46/50

Records with any of these codes should be reviewed by state staff and corrected if they belong on the CCS. Records with ARS Response Codes 33, 34, and 35 may also appear on CCS Table 1 since the national office system will assign these. (The records will appear on CCS Table 1 if the codes are assigned in the same edit run.) ARS Response Code 30 will only be assigned in the states, typically in the state ARS system. However, a CCS I-error flag would also be assigned to any ARS Response Code 30 record by the national office edit; otherwise, the system would have changed the ARS Response Code from 30 to 41 or 46. Records with ARS Response Codes 30 or 33 that have I-errors and require correction will also appear on Table 9B. (Response Code reassignment is described in Section 11.4.3.)

CCS Table 6: Records Excluded Due to Missing Code Changes

This listing, CCS Table 6, displays records on the national office micro file that have a current ARS Refile Year and an ARS Response Code 46 or 50, but do not have a true CCS code change as defined in Section 11.2. State staff should review these records to determine whether their Old fields and first quarter codes are accurate. If the record does not belong on the CCS, remove the ARS Response Code or assign some other, more appropriate code such as 41 (Reviewed, no CCS code change). Correcting the ARS Response Code on the state system will likely remove inappropriate records from the state CCS file.

CCS Table 8: CCS Records with Questionable Missing Employment/Wages

CCS Table 8, generated on request, displays records that are included on the CCS but have a questionable configuration of "missing" employment or wage data. That is, the records have indicator M for one or more of the economic data fields used on the CCS, where the configuration of missing data fields indicates a possible problem or failure with estimating data. This is explained in the latter part of Section 11.5.4.

EXHIBIT 11E CCS Table 5: Records with Response Code 30, 33, 34, or 35

DATE: 07/25/2005		TIME: 09:42:41 PM		(STATE)										PAGE 1					
INITIAL RUN 2005/1		RECORDS EXCLUDED DUE TO RESPONSE CODE 30, 33, 34, OR 35 (CCS TABLE-5)										**CONFIDENTIAL DATA**							
BUREAU OF LABOR STATISTICS - EQUI PROCESSING																			
UI ACCT.	RUN	EI NUMBER	TRADE/LEGAL NAME	A										4TH QTR			1ST QTR		
				X	U	OLD	OLD	OLD	Q-1	Q-1	Q-1	Q-1	RS	DEC	WAGES	JAN	FEB	MAR	WAGES
				NAICS	OWN	CTY	TWN	NAICS	OWN	CTY	TWN	CD	EMP	(\$000S)	EMP	EMP	EMP	(\$000S)	
0102002323	00000	410200103	BARBS TAVERN	0	336414	5	999	000	336414	5	085	000	34	0	0	0	80	83	676
0304001243	00002	410300198	S & P	0	445110	5	057	000	445110	5	057	000	34	13	102	26	44	42	92
0600088307	00007	874252522	ODD SERVICES	1	721214	5	065	000	721214	5	065	000	34	113	3655	103	96	88	2303
0600088307	00008	874252522	ODD SERVICES	1	999999	5	065	000	711320	5	065	000	34	0	0	185	166	113	2710
0801031714	00000	420100250	JLM&N SQUARE CONS	0	541330	5	900	000	541330	5	073	000	33	165	4055	136	128	130	3688
0801031714	00003	420100250	JLM&N SQUARE CONS	5	238990	5	037	000	238990	5	037	000	34	25	96	20	20	23	83
0801031714	00006	420100250	JLM&N SQUARE CONS	0	322121	5	025	000	322121	5	025	000	34	6	13	5	2	0	11
0801031714	00013	420100250	JLM&N SQUARE CONS	0	522292	5	075	000	532412	5	075	000	35	10	42	0	6	6	32
0800033003	00000	000000000	SOLDER OF FORTUNE	0	331494	5	081	000	331494	5	081	000	34	4	11	0	0	0	0
0801031614	00000	424344450	HEIGHO MINING SER	0	212399	5	037	000	212399	5	037	000	34	9	28	13	10	16	33

11.7.5 Summary of Differences Reports

CCS Table 7

The Summary of Differences Report generated by the national office system (CCS Table 7) is a formatted listing of the Summary of Differences file described in Section 11.6. For each record on the file (each county/ownership/industry cell affected by the CCS), the report shows data leaving, data entering, and the net change. Data leaving are labeled “from,” while data entering are labeled “to.”

There are two differences to note between the file and the report.

1. The report itself shows only two months of employment for each cell: December and January. However, the Summary of Differences file includes fields for all four months represented on the CCS: December, January, February, and March. The file has two fields for each month; one shows the employment entering and the other shows employment leaving.
2. While the report shows the net change to employment and wages, there are no net change fields present on the file. The net change is calculated when the report is generated, as well as when the Summary of Differences file is used by the macro edit for code change integration.

A sample of the Summary of Differences Report appears as EXHIBIT 11G.

CCS Table 7A

The Changes in the CCS Summary of Differences Report (CCS Table 7A) displays Summary of Differences records/cells that are changed as a result of an EQUI update. It shows, in a format similar to CCS Table 7, the Summary of Differences data from the previous run and from the current run, with a third line showing the amount of change. Table 7A gives analysts the capability to identify large changes in the Summary of Differences caused by EQUI data changes, beginning with first quarter EQUI update/subset runs and continuing through second quarter processing. Due to system limitations, the sort sequence is approximate; it is based on the net change to first quarter (January) employment.

EXHIBIT 11H shows a sample of the Changes in the CCS Summary of Differences Report.

EXHIBIT 11G Summary of Differences Report (CCS Table 7)

DATE: 07/25/2005		TIME: 06:07:08 PM		(STATE)				PAGE 1			
INITIAL RUN 2005/1		CODE CHANGE SUMMARY OF DIFFERENCES FOR 4TH QTR AND 1ST QTR (CCS TABLE-7)							**CONFIDENTIAL DATA**		
CELL		FROM (-)			TO (+)			NET CHANGE (+/-)			
CNTY/OWN/NAI	# OF CCS RECORDS	DEC/JAN EMPLOYMENT	TOTAL WAGES	# OF CCS RECORDS	DEC/JAN EMPLOYMENT	TOTAL WAGES	# OF CCS RECORDS	DEC/JAN EMPLOYMENT	TOTAL WAGES		
001 5 236115											
4TH QTR	2	7	28,704	0	0	0	-2	-7	-28,704		
1ST QTR	2	8	28,337	0	0	0	-2	-8	-28,337		
001 5 236118											
4TH QTR	0	0	0	1	1	5,350	+1	+1	+5,350		
1ST QTR	0	0	0	1	1	4,100	+1	+1	+4,100		
001 5 238122											
4TH QTR	1	6	24,545	0	0	0	-1	-6	-24,545		
1ST QTR	1	3	18,049	0	0	0	-1	-3	-18,049		
001 5 238131											
4TH QTR	0	0	0	1	3	8,016	+1	+3	+8,016		
1ST QTR	0	0	0	1	3	14,450	+1	+3	+14,450		
001 5 238171											
4TH QTR	1	1	5,350	0	0	0	-1	-1	-5,350		
1ST QTR	1	1	4,100	0	0	0	-1	-1	-4,100		
001 5 238211											
4TH QTR	1	8	42,944	1	10	43,161	+0	+2	+217		
1ST QTR	1	0	44,487	1	9	41,293	+0	+9	-3,194		
001 5 238221											
4TH QTR	0	0	0	1	8	42,944	+1	+8	+42,944		
1ST QTR	0	0	0	1	0	44,487	+1	+0	+44,487		
001 5 238292											
4TH QTR	0	0	0	1	0	1,350	+1	+0	+1,350		
1ST QTR	0	0	0	1	0	1,080	+1	+0	+1,080		
001 5 238321											
4TH QTR	0	0	0	1	2	3,900	+1	+2	+3,900		
1ST QTR	0	0	0	1	2	3,900	+1	+2	+3,900		
001 5 423220											
4TH QTR	1	9	53,884	0	0	0	-1	-9	-53,884		
1ST QTR	1	9	38,657	0	0	0	-1	-9	-38,657		
001 5 423450											
4TH QTR	0	0	0	1	9	53,884	+1	+9	+53,884		
1ST QTR	0	0	0	1	9	38,657	+1	+9	+38,657		
001 5 423830											
4TH QTR	0	0	0	1	8	69,106	+1	+8	+69,106		
1ST QTR	0	0	0	1	8	55,326	+1	+8	+55,326		
001 5 425120											
4TH QTR	1	3	69,861	0	0	0	-1	-3	-69,861		
1ST QTR	1	4	98,777	0	0	0	-1	-4	-98,777		
001 5 441110											
4TH QTR	1	1	3,000	0	0	0	-1	-1	-3,000		
1ST QTR	1	1	3,000	0	0	0	-1	-1	-3,000		
001 5 441120											
4TH QTR	0	0	0	1	1	3,000	+1	+1	+3,000		
1ST QTR	0	0	0	1	1	3,000	+1	+1	+3,000		

EXHIBIT 11H Changes in the CCS Summary of Differences report (CCS Table 7A)

DATE: 10/25/2005		TIME: 02:25:38 PM		(STATE)			PAGE 1			
INITIAL RUN 2005/2		CHANGES IN CCS SOD FOR 4TH QUARTER 2004 AND 1ST QUARTER 2005 - CCS TABLE 7A **CONFIDENTIAL DATA**								
BUREAU OF LABOR STATISTICS - EQUI PROCESSING										
CELL		FROM(-)			TO(+)			NET CHANGE (+/-)		
CNTY/OWN/NAI	# OF CCS RECORDS	DEC/JAN EMPLOYMENT	TOTAL WAGES	# OF CCS RECORDS	DEC/JAN EMPLOYMENT	TOTAL WAGES	# OF CCS RECORDS	DEC/JAN EMPLOYMENT	TOTAL WAGES	
086 5 336411										
1ST OLD	0	0	0	3	33	551,289	3	33	551,289	
1ST NEW	1	0	0	3	33	551,289	2	33	551,289	
NET	1	0	0	0	0	0	-1	0	0	
4TH OLD	0	0	0	3	33	556,614	3	33	556,614	
4TH NEW	1	374	2,794,276	3	33	556,614	2	-341	-2,237,662	
NET	1	374	2,794,276	0	0	0	-1	-374	-2,794,276	
086 5 611610										
1ST OLD	5	17	196,176	3	15	173,171	-2	-2	-23,005	
1ST NEW	5	17	196,176	4	15	173,171	-1	-2	-23,005	
NET	0	0	0	1	0	0	1	0	0	
4TH OLD	5	17	185,595	3	17	242,815	-2	0	57,220	
4TH NEW	5	17	185,595	4	391	3,037,091	-1	374	2,851,496	
NET	0	0	0	1	374	2,794,276	1	374	2,794,276	
****END OF SUMMARY OF DIFFERENCE CHANGE REPORT****										

11.8 Additional National Office Processing of Code Change Data

The national office system also performs additional functions. In particular, it generates files and listings for data users, and it can generate an additional report on request: the CCS Master List.

Important users of the data are the Current Employment Statistics (CES) program, which uses CCS data in conjunction with employment benchmarking activities; and the Bureau of Economic Analysis (BEA), which uses CCS data to track data movement between fourth and first quarter macro data.

CES receives a National Summary of Differences file, which summarizes CCS data for all States to show data entering and leaving each affected ownership/6-digit industry code, as well as the net changes.

For non-signatory states, BEA receives a Macro CCS file aggregated by ownership/6-digit industry code/county code. For signatory states, BEA receives a CCS micro file.

The national office system can generate, on request, CCS Master Lists of state CCS files. A sample page of the CCS Master List is provided as EXHIBIT 11I. The master list is a report showing every record on the CCS file, displayed in similar format as the four reports covered in the previous section. Master Lists are sorted by Old Ownership/Old NAICS/UI Account Number/Reporting Unit Number, in ascending order.

The CCR Micro 1 Review File lists all of a State's CCS records and is an alternative to the CCS Master List. More information about the CCR Micro 1 Review File can be found in Chapter 13.

EXHIBIT 11I CCS Master List

DATE: 08/08/2005		TIME: 02:36:26 PM		(STATE)										PAGE 1							
RUN 2005/1		BUREAU OF LABOR STATISTICS - EQUI PROCESSING										**CONFIDENTIAL DATA**									
				CCS MASTER LIST																	
UI	ACCOUNT	RUN	EI NUMBER	TRADE/LEGAL NAME	A	U	OLD	OLD	OLD	OLD	NEW	NEW	NEW	NEW	RS	DEC	4TH QTR	JAN	FEB	MAR	1ST QTR
					X	NAICS	OWN	CTY	TWN	NAICS	OWN	CTY	TWN	CD	EMPL	EMPL	(\$1000S)	EMPL	EMPL	EMPL	WAGES
0230343120	00008	769915696	PHLEMCORP	5	541820	5	062	000					056	50	0		0	8	7	7	30
0460716048	00000	871745273	RANT AMERICA	5	515112	5	066	000	515111					46	5		25	5	5	5	24
0560086052	00000	873842488	ASSOCIATED SOULS & GH	5	443112	5	066	000	512120					46	116		392	113	116	115	498
0720532079	00000	959986398	DR OPTIMIST LENS CO	5	443112	5	066	000	443120					46	2		37	2	2	2	38
0310601035	00002	911323439	EGAD DISCOUNT LIVEWAR	5	443120	5	066	000				048	50	12			33	11	11	11	40
0570357053	00004	872848484	PC INTROSPECTION COMP	5	443120	5	066	000				048	50	0			0	5	5	5	28
0570357053	00005	872848484	PC INTROSPECTION COMP	5	443120	5	066	000				086	50	0			0	5	5	5	28
0670067062	00000	872637167	WHIZCO SALES CORP	5	443120	5	066	000	421440					46	1		6	1	1	1	3
0750315077	00000	872257423	ABC PRIZE INC	5	443120	5	066	000	443120					46	7		20	5	5	3	22
0790669075	00000	873355231	PINPOINT BALLOONS INC	5	443120	5	066	000	443120					46	2		13	2	0	0	4
0810341084	00000	877452141	MAC'S MICROCOMPUTER	5	443120	5	066	000				048	50	14			98	12	12	11	38
0650675062	00000	870053100	US CONCOCT SALES CO	5	451220	5	066	000	443120					46	30		321	31	33	37	356
0800650289	00000	872457448	WINFIELD LODGE & STOR	5	711110	5	066	000				070	46	20			24	15	20	20	16
0870657081	00002	871456142	BONGERS	5	711110	5	066	000				086	50	32			52	29	31	31	49
0610451060	00013	878150419	RAT RACK BREWING COMP	5	722410	5	066	000	711110					46	4		24	4	4	4	24
0890319084	00000	877454148	CARVING ENTERPRISES I	5	722410	5	066	000	624410					50	11		12	9	10	11	13
0610291060	00000	227883488	BAGGETTS BODY SHOP IN	5	446110	5	066	000	446199					46	23		57	20	18	18	50
0760006078	00001	873252522	NATIONAL PRONOUNCEMEN	0	446110	5	066	000	454390					46	9		1317	0	0	0	0
0760006078	00002	873252522	NATIONAL PRONOUNCEMEN	0	446110	5	066	000	454390					46	115		1913	0	0	0	0
0760006078	00003	873252522	NATIONAL PRONOUNCEMEN	0	446110	5	066	000	454390					46	4		193	0	0	0	0
0730183076	00001	874252522	ODD SERVICES	0	446110	5	066	000	454390					46	83		1499	78	78	80	901
0730183076	00003	874252522	ODD SERVICES	0	446110	5	066	000	454390					46	103		1103	251	254	269	3644
0730183076	00004	874252522	ODD SERVICES	0	446110	5	066	000	454390					46	48		531	0	0	0	0
0730183076	00007	874252522	ODD SERVICES	0	446110	5	066	000	454390					46	232		2454	261	266	261	3052
0730183076	00008	874252522	ODD SERVICES	0	446110	5	066	000	454390					46	185		2509	0	0	0	0
0730183076	00009	874252522	ODD SERVICES INC	5	446110	5	066	000	454390					50	0		0	179	182	176	3383
0730183076	00010	874252522	ODD SERVICES INC	5	446110	5	066	000	454390					50	0		0	8	8	8	120
0730183076	00011	874252522	ODD SERVICES INC	5	446110	5	066	000	454390					50	0		0	0	1	1	28
0530833054	00000	877943691	FRONTAGE THRIFT INC	5	522298	5	066	000				086	46	32			80	32	32	32	76
0780438076	00000	874353535	FATNESS FIRST INC	5	451110	5	066	000	421910					46	5		51	5	5	5	36
0860266086	00000	930114519	PAMPAS RETAIL OUTLETS	5	451110	5	066	000	448210					46	13		27	11	9	9	24
0840944081	00012	417096207	G DOLTEN COMIX	5	451211	5	066	000				086	50	0			0	3	3	3	10
0660716062	00000	878155414	GRANT SLAP SPORTS	5	451120	5	066	000	446199					46	2		4	2	2	2	4
0590789051	00000	876946096	PUN SERVICE EVENTS IN	5	453220	5	066	000	532299					46	25		25	14	14	14	18

*** CONFIDENTIAL DATA **** FOR STATISTICAL USE BY AUTHORIZED PERSONNEL ONLY, DESTROY ACCORDING TO RECORDS RETENTION SCHEDULE.

11.9 Cleaning CCS Data

States should perform their review and clean-up of CCS data in coordination with the general cleaning of first quarter data for other purposes. The EQUI correction files should address CCS issues as well as I-errors, macro flags, multi-unit discrepancies and so on. CCS issues include addressing edit flags on the Micro Edits Only listing (Table 9B) as well as reviewing CCS output tables. In first quarter, the regular 30-day clean-up schedule applies to the CCS as well as the normal data problems that can occur in any quarter.

Meanwhile, the national office will follow up with the state where necessary regarding records with code changes and large employment (on CCS Tables 1A and 1B) or possibly other records listed on reports described in Section 11.7. Some issues of concern to BLS may not be resolved within the 30-day clean-up period, and may continue into second quarter processing. Meanwhile data changes and corrections that states make for other purposes can continue to change CCS files in the national office, as long as the national office system is used to regenerate those files. Although the national office does not close out CCS processing and generate final versions of the files until all related issues are solved in every state, a complete and accurate National Summary of Differences must be generated in a timely manner.

In brief, CCS processing in the national office is performed in the first and second quarters. Afterwards, CCS processing in the national office is discontinued for the remainder of the year.

Chapter 12 – Preparing and Transmitting the EQUI

The state systems generate files of EQUI records with the specified layout, including the required data elements, from the state system databases. By using standardized processes to update and edit data and then generate an EQUI file, the state provides BLS with all its micro level employment and wage data, pertinent administrative data and corrections to these data fields for all unlocked quarters. This ensures substantial consistency between state and BLS data.

----- Contents of Chapter 12 -----

- 12.1 State Processing to Generate a Clean Deliverable
- 12.2 Creating the Deliverable EQUI File
 - 12.2.1 EQUI Records and Transaction Types
 - 12.2.2 Changes to Records
 - 12.2.3 Special Measures to Maintain Consistency between Files
 - 12.2.4 Corrections and Updates for Earlier Quarters
- 12.3 Transmitting the File
 - 12.3.1 Transmittal Options
 - 12.3.2 Using the QCEW Program Data Transmittal Form
- 12.4 Sending Test Files When Making System Changes
- 12.5 File Retention

12.1 State Processing to Generate a Clean Deliverable

Each state varies in size, UI system, organization, etc. The state QCEW systems offer states the flexibility to choose processing and editing options that work best in their environment. States have some leeway in selecting processing jobs and their timing in order to create an ideal schedule for delivering clean, comprehensive employment and wage data to BLS on a quarterly basis. Appendix E contains a suggested quarterly processing sequence.

States have several processing options within each standardized system:

- OPTION 1: Edit micro data on an on-going basis and then run the integrated edit during the last few weeks of processing.
- OPTION 2: Impute all missing or delinquent data when the first extract is loaded. Then edit all data through the integrated (micro and macro level) edits throughout the production cycle.
- OPTION 3: Edit micro data on an on-going basis. At a selected cut-off, impute all missing or delinquent data. After that, include in the integrated edit all previously edited micro records as well as all new micro records not previously edited. The integrated edit output will list flagged new micro records, previously flagged records with remaining invalid errors, and all flagged macro records.

States also choose between two editing and processing systems: WIN and EXPO. Though managed separately, these two systems share similar characteristics. Both systems provide a series of partial or specialized edits that flag such characteristics as unbalanced multi-accounts, gross errors, and incorrect ARS responses. These edits, which can be routinely run throughout the quarter, flag micro data that exceed certain parameters, are erroneous or are missing processing codes.

Both systems also provide comprehensive integrated edits that screen micro and macro data for outliers and identify missing data. Though integrated edits can be run at any time during the quarter after imputation, they *must* be run and reviewed near the end of the processing cycle -- after all new UI or MWR/EDI files have been loaded and just before EQUI submittal. Once an integrated edit is run for a current quarter, however, the State should not switch back to editing micro records only but should continue editing in an integrated edit mode.

In addition to pre-programmed edits, both systems provide state the flexibility to write customized queries (Progress queries for WIN and 40D for EXPO) to root out data issues not captured by typical routines. For systems' manuals and examples of state processing schedules, visit [StateWeb](#).

Each State should work with their regional office to ensure that their processing schedule will produce clean, timely data.

Options

Option 1: Running the Micro Edit Before Running the Full Integrated Edit

Advantages:

- Reported micro data can be edited early in the production cycle. (Initial review of first micro extract.)
- Allows the user to edit, update, and assign comments to micro data prior to processing macro data.
- Allows states to more frequently extract data and spread out review and correction work across more work weeks.

Disadvantages:

- Does not prioritize effort toward finding issues creating the largest distortions in local and state macro data.
- Less efficient than concurrently resolving micro problems and viewing impact on macro data.
- Does not utilize other data in the cell to assist in the micro data review.

Option 2: Running the Full Integrated Edit

Advantages:

- Prioritizes effort toward finding issues creating the largest distortions in local and state macro data.
- Easier to monitor industry patterns and other economic occurrences in your state.
- Ability to more quickly see large economic changes in your state. Useful during recessions and recoveries, and after natural disasters.
- Easier to determine the impact of the micro records on the macro data, if data are simultaneously processed at both the micro and macro levels.
- More efficient to resolve all questions associated with a micro record at one time, including both micro issues and their impact on the macro level.
- Greater assurance that all edit flags are addressed.

Disadvantages:

- You will review an imputed version and a reported version of the same micro record within a few weeks' time when employers send late data.

Option 3: Combination of Approaches

Edit earlier extracts with the microdata editing processes; switch to integrated edits for later extracts. For example, if only two current quarter UI Tax File extracts are run, edit the first extract using the micro edit programs. Use the integrated edit for the second round of extracted micro data. The integrated edit should also be used to continue editing any unresolved micro errors/failures and imputed missing or delinquent micro data. If more than two extracts are run,

this approach should be modified based on the timing of the extracts and when the imputations are generated.

Advantages:

- Reported micro data can be edited early in the production cycle. (Initial review of first micro extract.)
- Comments can be assigned and problems corrected closer to the time the reports are actually received from the respondent.
- Once the integrated edit is run, all associated flagged micro records are listed with the macro cell. Your review of the previously processed micro records may identify an economic condition or pattern within the macro cell. It may take fewer resources to review the remainder of the records with similar data movement.
- You have an opportunity to easily determine the quality of the imputations on both the micro and macro data and address problems.
- More time to resolve issues creating the largest distortions in the local and state economic story.

Disadvantages:

- Records previously addressed reappear each time you review the record

Tax System Cutoffs

State staff should work with the regional office to establish a cut-off date, after which the state will not import any new data from the tax system. This cut-off date needs to allow state staff enough time to complete edits and ensure a clean EQUI file. Late data that does not make the cut-off can always be extracted, edited, corrected, and transmitted as prior quarter data in the next EQUI submittal.

12.2 Creating the Deliverable EQUI File

The state systems generate a file of EQUI records with the required data elements in the specified layout. When the state systems generate standardized EQUI files, they include:

- Non-quarterly (administrative) fields
- Multiple quarters of data
- New reporting units (new UI/RUNs) not previously reported
- New quarterly data for UI/RUNs reported previously
- Data changes for UI/RUNs reported previously in the current or earlier quarters

State systems do not generate EQUI records for establishments with a Type of Coverage code of 8 (not covered). However, they do generate records for units with a Status Code of 2 (inactive) if additional information is available after the inactive status was first assigned. All remaining

records are included on the EQUI, including master records with an MEEI code of 2. The same file may also contain back quarter records, also in the EQUI format.

All records must include the appropriate Transaction Code, state FIPS Code, Year, Quarter, UI Account Number, and Reporting Unit Number to be loaded to BLS files. The format used for all data records is detailed in Appendix K.

The update process allows states to submit the current quarter data to BLS along with corrections/updates for up to four previous quarters. The Cooperative Agreement requires at least one extraction and review of late and retroactive prior quarter data for every new processing quarter, so each EQUI deliverable file will contain data for at least two quarters. States may continue to correct the current and previous quarters on a flow basis during the BLS review period.

Normally, all EQUI data available for the current quarter or any back quarter unlocked in BLS are submitted together. Once received in the national office, the data are loaded together and all quarters of data for a given record are processed and edited together. Once the current quarter file is submitted, corrections to it and/or other back quarters should be submitted in compliance with the correction policy.

12.2.1 EQUI Records and Transaction Types

The standardized systems create the following types of record entries:

- Header record
- Trailer record
- Initial current quarter active records
- Updates to current quarter micro data
- Updates to prior quarter micro data
- Initial records for one or more back quarters of micro data
- Deleted records
- Inactivated records
- Reactivated records
- Updates to administrative or non-quarterly data
- Predecessor/Successor Linkages

Five transaction codes, corresponding to transaction types, are used in the first position of each EQUI record.

TRANSACTION TYPES AND CODES

<i>Transaction Type</i>	<i>Transaction Code</i>
Header record	H
Trailer record	T

Deleted record	D
Full data record (all fields provided)	F
Predecessor-Successor Supplement	P

The format of each record type is provided in [Appendix K](#).

Header Records (H):

The header record contains detailed control information about the file submitted (e.g., volume serial number, record length, block size, creation date and time); information identifying the processing State, year, and quarter; and information about the State editing parameters and tolerances.

Trailer Records (T):

The trailer record provides summary information on the number of records in the transmission, as well as establishment counts and employment and wage totals by year, quarter, and ownership. BLS-Washington compares the trailer record with EQUI micro data to ensure that BLS was able to read all of the data included on the file.

Delete Records (D):

A “delete” or **D record** has the effect of removing all data on the file for that unit, regardless of how many quarters are on the file. States should delete erroneous UI Account Number and Reporting Unit Number combinations that never belonged on the state system. These are actually removed in EXPO while WIN inactivates all quarters and hides the data. “Delete” records should not be confused with “inactivate” records (units that are out of business, were sold, or subunits which ceased to be reported separately). A change in the Status Code to a “2” inactivates the record, but its historical data are retained on the file.

The standardized system will generate “delete” records with the following fields:

"DELETE" RECORD FIELDS

Positions	Length	Data Element
1	1	Transaction Code = “D”
2-3	2	State FIPS Code
4-7	4	Year
8	1	Quarter
9-18	10	UI Account Number
19-23	5	Reporting Unit Number

To delete an entire multi-establishment family, a "D" record must be sent for each subunit as well as the master record.

If the user designates a record for deletion, the system will automatically change the status code for the record to "inactive" for all open quarters. Deletions should be rare, since all quarters of data will effectively be removed. The user should be very cautious when deleting data. Only those records that were written to the state system in error should be deleted.

If, however, only the current quarter micro data should be deleted or a particular segment of the file, the fields should be zero- or blank-filled on quarterly occurrence fields, as appropriate. Inactive records should be assigned an end of liability date and an inactive status (Status Code 2) on the state system to avoid imputing for missing data.

The state should maintain a transaction file or audit trail and back up files in case large segments of the file are incorrectly deleted. If a few records are incorrectly deleted, the state should add the data for all appropriate quarters.

Full Data Records (F):

These update records provide normal data using every field. Every EQUI data element that is present on the state system for the specified year/quarter is included on these records, whether or not they were transmitted to BLS already. The state systems generate these records in the EQUI format with the following fields:

- Transaction Code of "F" in the first position of the EQUI record
- State FIPS code
- Year
- Quarter
- UI Account Number
- Reporting Unit Number
- All other EQUI data elements as they exist on the state system

During an update, if a matching BLS record exists, Transaction Code F tells the BLS system to overlay all relevant data elements on the BLS micro file with the contents of the EQUI record. For example, an EQUI update record with Transaction Code F may have a blank Trade Name field. This indicates that no Trade Name is present on the state system; therefore, the Trade Name will become blank on the BLS file as well (whether or not it was blank before).

Predecessor/Successor Supplemental Records

Predecessor/Successor supplemental records provide detailed information about the relationship between a predecessor and its successor. A pred/succ supplemental record is generated for each EQUI data record with a comment code of 85, 86, 87, 92, or 93. This means that for each identified pred/succ relationship (or pair), two pred/succ records are generated: one for the predecessor and one for the successor.

12.2.2 Changes to Records

Changes to Numeric Data

If you change a numeric field (such as employment, wages, or contributions) to zero on the state system, the same occurs on the EQUI. If you change an alpha-numeric field to blank on the state system, the system will blank out that field on the EQUI. This in turn converts the field on the BLS file to blanks.

An example of reporting alpha-numeric field changes

Quarter	Submitted	Change to second line of street address...
2019/1	August	Includes "Suite 7431"
2019/2	November	Is blank
2019/3	February	Is reported as blank

In the third quarter of this example, the field is reported as blank because it was already blanked out on both the state and BLS systems in the prior quarter.

Changes to Inactive Records:

If a record is inactivated for a quarter and the EQUI submittal is the first submittal for that record for that quarter, then all fields are submitted. This includes zeroes in the employment and wages and "M" (missing) in the employment and wage indicator fields. A "2" (inactive) appears in the Status Code field.

For records becoming inactive, the state systems send a full EQUI record only for the first inactive quarter. The state systems are not required to send EQUI records for subsequent quarters unless there is a change to at least one field on the EQUI (e.g., successor UI/RUN, end of liability date, quarterly data, etc.). If a record is already inactive and you are updating other data fields (e.g., end of liability date), the system will still send a full record.

If data were reported or imputed during the time that a record is inactive, the employment and wage data will remain on the file unless the state physically alters the data to zero. Altering is not required since the Status Code is searched in all aggregation programs, and output programs bypass all inactive records. For example, inactive records are always excluded from the macro file.

Any new information added to inactive records for any unlocked quarter maintained on the state system is sent to BLS for use in longitudinal research (see Appendix W).

Changes to Non-quarterly or Administrative Records

Administrative or non-quarterly fields can be changed in any quarter consistent with the correction policy. Non-quarterly fields are updated on the BLS file regardless of the year/quarter as long as the year/quarter combination of the EQUI record is unlocked on BLS files. If the reference period is locked, the BLS system will not update the record.

If multiple quarters are submitted on the same EQUI, all the data will first be loaded to the BLS micro file and then edited. For example, if three quarters are submitted for the first time for a record, and all data are reported each time, the non-quarterly data will only be edited once.

When to Include Administrative Data

Administrative Data / Non-Quarterly Data	Data Fields Submitted	Included with These Records
Active accounts	Any data for active accounts.	<ul style="list-style-type: none"> • All active single, sub-unit, or master UI- or UCFE-covered records on state system. • Records reporting retroactively, also include quarterly occurrence for the reference and prior quarter.
Inactive accounts	Missing Dates <ul style="list-style-type: none"> • End of Liability • Input (Setup) • Reactivation • Initial Liability UI#/RU# <ul style="list-style-type: none"> • Predecessor • Successor Status Code ARS <ul style="list-style-type: none"> • Response Code, • Refile Year, • Old Fields, etc. 	Any inactive single, sub-unit, or master UI- or UCFE-covered record on state system that has not been archived off the file.

Note: Each time a record is submitted for one or more back quarters of data, it includes all data fields in the EQUI format. This includes current administrative or non-quarterly information, because only the most current administrative data is maintained for each record. For example, if a unit was not on the state system for an earlier quarter, but research indicates the physical location differed during that time period, enter the most recent information on the state system to be updated on the EQUI file. If both the current and prior quarter are submitted on the same file for a specific UI/RUN, both records would contain the same administrative information since both would be full records.

Reactivated Records:

If a record is reactivated, it is submitted on the EQUI with a "1" (active) in the Status Code field. The Status Code field is a quarterly field which is populated in state systems based on dates, in this case, by the reactivation date.

12.2.3 Special Measures to Maintain Consistency between Files

The state systems can generate special EQUI files that provide full data for one quarter only, or that provide data only for specified reporting units. Processing problems may sometimes occur that cause significant inconsistencies between data on the state system and data on the BLS micro file. Following consultation with their regional office, states can generate one of these special files to bring state and BLS data back in sync.

A one-quarter EQUI file provides an EQUI record for every status 1 (active) and status 2 (inactive) record on the state system for the specified quarter. This file replaces all data on the BLS micro file for the matching UI/RUNs for the specified quarter.

States can also submit a subset EQUI file. A subset is a special file that provides data for specified reporting units and can be used to fix serious errors and restore consistency just prior to BLS publication. Subsets create additional review work at BLS when time is very limited. Almost all publication issues are resolvable using corrections made at BLS. When BLS needs a subset for publication purposes, BLS national office staff will typically share information regarding the specific records desired for inclusion on the subset. This information is sent to the regional office for transmission to the state. BLS publication closeout is most efficient when only the requested records are included in the subset. The state systems generate the subset EQUI file using, as input, a file of identifying information. The input file contains the state FIPS code, Year, Quarter, UI Account Number, and RUN for each record needed. The state system finds the matching record and creates the corresponding EQUI records. These are full EQUI records containing all available data for the specified quarter, plus all available non-quarterly data. EQUI subset file records have a status of either 1 (active), 2 (inactive), or 9 (pending).

12.2.4 Corrections and Updates for Earlier Quarters

Consistency between state and BLS data is generally maintained by updating the state system and providing BLS with all micro level corrections made to the state system for all unlocked quarters. EQUI files, correction files, update files and subset files all transmit updated data from state systems to BLS. BLS staff can also make changes to microdata in the BLS processing system in order to reduce the need for a subset file.

Extract Requirements

All states follow the same minimum requirements for collecting employer data. States must extract all current quarter data at least twice per quarter and prior quarter data at least once per quarter. Extracts pick up all new and changed account information occurring since the previous extract. Note that the prior quarter is defined as the quarter immediately preceding the current reference quarter (e.g., if the current reference quarter is 2019/4, then the prior quarter is 2019/3).

Initial extracts for the quarter include all data for the current quarter, including any non-quarterly or prior quarter fields that may have changed. Most states run two or three extracts each quarter

while a few run them weekly or daily. Because the state UI tax agencies do not follow the same data review guidelines as those required by BLS, state processing systems have procedures for locking selected fields. These can be locked to protect data that have already been reviewed, so they are not replaced by data of lesser quality coming in with consecutive extracts. Each state system also has a mechanism to compare extracted data against locked data to manually determine if changes are needed.

Prior quarter data extracts, as well as multiple extracts for the current quarter, are run to obtain later arriving data from UI and information on retroactive accounts set up since the last extract. Late data are loaded to the files to replace imputations. Current imputation procedures only allow one to two quarters of imputation before the data are zero-filled. BLS places tolerances on the amount of imputed data permissible, both over time and as a percent of the total file; the ability to capture actual reported data from nearly all American businesses is a hallmark of the QCEW program's data quality and utility. By replacing estimates with late data, the state can reduce the amount of imputed data on file, and also reduce the number of consecutively imputed quarters for some records, thus preventing active accounts from being dropped.

Any QCEW program information added to the UI tax file or other source files relating to inactive accounts that still reside on the state system is also extracted. Information from inactive accounts may include more accurate end of liability dates as well as information on their possible successors.

For example, an account reports on the Quarterly Contributions Report (QCR) through 2016/2, is imputed for 2016/3 and 2016/4, and zero-filled for 2017/1. Staff manually inactivates the record after 2016/2 by providing an end of liability date of July 1, 2016. During the 2017/3 extract, the End of Liability Date and a Successor UI Account Number are also extracted for the record. The inactive record on the state system is updated with this information so the correction will be provided to BLS. These data fields provide greater detail on deaths on the file, and predecessor/successor information, both of which will be used extensively for longitudinal research purposes as discussed in Chapter 5.

Most states use a copy of the state system micro file to compare extracted data against previously received data to determine if changes are needed. Options for identifying what to include on the extract are:

- Compare a version of the state system micro file to what is on the UI tax system for the fields on the system. These frequently use EXPO and WIN output files referred to as the 76 jobs to use in the comparison.
- Compare the last extract to the tax system to identify anything new or different
- Compile transactions to the tax system that occurred to fields on the state system since the last extract
- Dump of the tax file fields used in the state system and loading only those data elements that are new or different from what is already on the file.

Key Features of the Correction Policy

- Automated Transfer of Corrections to BLS Files**
 The state systems generate EQUI correction records that are submitted to BLS. This approach ensures substantial consistency between the files and minimizes errors. The EQUI file generation process creates a file of every changed record since the last EQUI file output. The “last EQUI file” can be an initial file, an update file, and in some cases, a subset file.
- Automated Correction of Macro Files from Micro Files**
 All corrections impacting employment and wage data made to the state systems are applied to the macro file when it is re-aggregated. These include changes to employment, total wages, county code, NAICS, ownership, MEEI, and status. No corrections are directly made to the macro data, either in the states or BLS.

The correction policy is summarized on the chart that follows. Specific points are listed below.

QCEW CORRECTION POLICY

<i>Any correction/update made in the state to quarters that are unlocked in BLS is transmitted to BLS to maintain consistency in the files.</i>					
Current (reference) Quarter (Quarterly Occurrence Data)	Example	Extract from UI tax and other information sources (required for quarters noted)	Example	Quarters which can be corrected/updated on BLS files	Example for BLS files
First	2020/1	Fourth of prior year and first of reference year	2019/4, 2020/1	Must update fourth quarter of the prior year and the reference quarter; may update first, second, and third quarters of the prior year	2019/4 and 2020/1 required; may update 2019/1, 2020/2, and 2020/3
Second	2020/2	First and second of reference year	2020/1, 2020/2	Must update only first and second quarters of the reference year	2020/1 and 2020/2 required
Third	2020/3	Second and third of reference year	2020/2, 2020/3	Must update second and third quarters of the reference year, may update first quarter of the reference year	2020/2 and 2020/3 required; may update 2020/1

Fourth	2020/4	Third and fourth of reference year	2020/3, 2020/4	Must update third and fourth quarters of the reference year, may update first and second quarters of the reference year	2020/3 and 2020/4 required; may update 2020/1 and 2020/2
--------	--------	------------------------------------	----------------	---	--

Unlocked Quarters on state and BLS Files:

For those quarters that are unlocked on BLS files, all corrections made to the state files are submitted to BLS.

For the prior and current quarters, extract data from the tax file or other sources for all new information available since the last extract. This includes:

- Active accounts
- Retroactive or reactivated accounts
- Reported data for delinquent accounts
- Other corrections

These changes must be made to the state micro database so the state can transmit them to BLS on the EQUI. Any current and prior quarter corrections that impact earlier unlocked quarters are then made to both state and BLS files. State systems permit extracting UI data back for many prior quarters, but BLS only requires the extract of the immediate prior quarter.

Updates to Macro Data

All macro file data are derived from the micro database file, in both the states and BLS. Once the state system is updated, the macro file is recreated using the updated micro file. Many data elements submitted on the EQUI will not affect macro data. Some of these include addresses, names, telephone numbers, and EINs. Other elements like industry, county, and ownership codes, monthly employment, and total wages do affect the macro records. (Macro data processing is discussed in more detail in Chapter 10 – Macro File and the Integrated Edit.)

Some changes to micro data may result in two macro cells being changed. For instance, if a private sector restaurant is updated and re-coded from county code “031” to “059,” both macro cells 722110/5/031 and 722110/5/059 will be updated and edited.

12.3 Transmitting the File

There are two common methods for transmitting EQUI data to the national office. EQUI data files must not be sent to the national office via e-mail under any circumstances due to BLS data security provisions. The approved methods are:

1. Submitting as a Service Center State
2. Submitting files using EUSWeb

The following criteria should be used in determining the appropriate method.

- If a state is using the Service Center for processing, they also use the Service Center for submission of the EQUI.
- Non-Service Center States, WIN States and Service Center states alike can use EUS Web for submittals.
- FTP transfer is also a possibility as a backup, but this must be coordinated and tested in advance on a case by case basis, and so it is not described in detail here.

12.3.1 Transmittal Options

1. Submitting as a Service Center State

For Service Center States, the creation of EQUI deliverables is done at the Service Center. Though all handling is done on-site, information regarding the exchange and processing of data must still be communicated.

- a) Service Center States creating their deliverable at DMA use the following naming conventions which must be maintained for processing:

The initial quarterly (primary) submittal and EQUI correction (or secondary or update) files, use the following naming convention:

DSN = ACTINT.ACCT.EQUI.DATA.STYRQ

Where:

ACTINT = the state's account and initial assigned at DMA
(example = YBU10W for Delaware's)

ACCT = the account at DMA (example = A145 which is Delaware's)

ST = State postal abbreviation (example = DE for Delaware)

YRQ = the most recent processing year and quarter contained on the file
(example = 204 for the 2020 fourth quarter)

A complete example would be DSN = YBU10W.A145.EQUI.DATA.DE204 for the 2020/4 file from Delaware.

One-quarter EQUI files and EQUI subset files (described in Section 12.2.3) use the following naming convention:

DSN = ACTINT.ACCT.EQUI.FED.STYRQ

Where:

ACTINT = the State's account and initial assigned at DMA
(example = YBU10W for Delaware's)

ACCT = the account at DMA (example = A145 which is Delaware's)

ST = State postal abbreviation (example = DE for Delaware)

YRQ = the most recent processing year and quarter contained on the file
(example = 204 for the 2020 fourth quarter)

A complete example would be DSN = YBU10W.A145.EQUI.FED.DE204 for the 2020/4 file from Delaware.

- b) After file creation, the state should catalog their dataset and send DBES a completed QCEW data transmittal form. Send the transmittal form via e-mail to the group name “**EQUI Submittals**” with a copy to the regional office. This will get the form directly to a group of people responsible for EQUI processing or interested in file receipts. **Follow the directions in Appendix S when completing the email subject line.**

2. Submitting Files Using EUSWeb

EUSWeb is another method for transmitting the EQUI and update transaction files. The procedures for using EUSWeb are documented in the EUSWEB User's Guide that can be accessed at <http://199.221.111.170/content/EUSWEB.doc>. States must conform to the proper format, naming conventions, and compression conventions given below.

- <http://199.221.111.136/default.aspx>
- For format, files must be saved in ASCII (text) format.

For the file name, state must use the following standard naming convention. This step is necessary for correct routing of the files. States should put their initial (primary) EQUI files in the MCR directory and put update (secondary, correction, subset) files in the CRX directory.



Bureau of Labor Statistics - FSMS - EUSWeb 2017.1.0

[Download](#) [Upload](#) [Log](#) [My Account](#) [Elvis](#) [Log Out](#)

Programs:

[General Forum](#)
[CES Program](#)
[QCEW Program](#)
[LAUS Program](#)
[OES Program](#)
[PROMIS Program](#)
[OSHS Program](#)
[Inter Office Transfer](#)

Select a file type:

[CARS Files for BLS](#)
[MWR Web History](#)
[State QCEW CRX \(Micro Correction\) Files](#)
[State QCEW MCR \(Micro\) Files](#)
[TRS Files for BLS](#)

For a primary EQUI submittal:

File Name = STMCRYQN.txt

Where:

ST = the State postal abbreviation (example = DE for Delaware)

MCR = the constant portion of the EQUI file name that is used for pollster routing

Y = the last digit of the most recent year

Q = most recent quarter

N = an incremental field in case a state has more than one file to transmit for the same year/quarter

A complete example would be file name = DEMCR741.TXT for Delaware's initial submittal of their EQUI in 2027/4.

For a secondary/correction/subset file:

File Name = STCRXYQN.txt

Where:

ST = the State postal abbreviation (example = DE for Delaware)

CRX = the constant portion of the correction file name that is used for pollster routing

Y = the last digit of the most recent year

Q = most recent quarter

N = an incremental field in case a state has more than one file to transmit for the same year/quarter

A complete example would be file name = DECRX742.TXT for Delaware's second update transaction file in 2027/4.

Files over 1MB in size must be transmitted in zipped format; while files of any size can be transmitted in this format. States may use a standard product such as PKZIP or WinZip. When zipping files, states should put each text file in a .zip file with the same naming convention (except for the extension). For example, the zipped version of DECRX832.TXT would be called DECRX832.ZIP.

Once the file has been posted to EUSWeb, the completed transmittal form should be sent via e-mail to DBES at the group name "EQUI_Submittals" with a copy to the regional office.

Follow the directions in Appendix S when completing the email subject line. This will get the form directly to a group of people responsible for EQUI processing, or interested in file receipts.

12.3.2 Using the QCEW Program Data Transmittal Form

The QCEW Program Data Transmittal Form (EXHIBIT 12A) was designed to be stored and filled out electronically in Microsoft Word.

DBES compares the record counts on the transmittal sheet to the file sent by the state. DBES reaches out to the state via the regional office regarding any discrepancies. If the counts don't match, DBES will not process the file until the two are reconciled.

The following procedures give some general guidelines for using the form.

Acquiring the Transmittal Form

The EQUI data transmittal form is available via the StateWeb server on the QCEW program page under QCEW Quick Links. Right click that link and select "Save target as..." to save a copy of the form to your computer.

http://199.221.111.170/Programs/QCEW/quick_links/2019_EQUI_Transmittal.docx

Completing the Transmittal Form

When filling out the form, make sure that only one box is checked in items with multiple check boxes. If you check the "Other" box, be sure to include the appropriate information in the space provided. Finally, if additional information is helpful for any specific item or the file in general, provide the information in the "Remarks" section of the form. (For example, if the file is a test file.)

Saving the Transmittal Form

The state should save a copy of the completed form. Use a file naming convention that identifies the year, quarter, and number of submittals within the quarter (1st tape, revised tape, etc.). For example, the State of Virginia may save its first EQUI transmittal form for 2020/4 as EQUI2020-4VA1.doc, where "...VA1" would indicate Virginia's first submittal. Subsequent submittals would be labeled "...VA2", "...VA3", etc.

Sending the Form

E-mail the form to "**EQUI_Submittals**" and copy your regional office. Follow the directions in Appendix S when completing the email subject line.

EXHIBIT 12A QCEW Program Data Transmittal Form

U.S. Department of Labor



Bureau of Labor Statistics
 QCEW Program Data Transmittal Form

1. State []	2. Date of Transmittal (MM/DD/YYYY) []	
3. Volume Serial Number (at DMA, if available) []	4. Transmittal <input type="checkbox"/> Primary File <input type="checkbox"/> Secondary File <input type="checkbox"/> Subset File <input type="checkbox"/> Other (Specify): []	
5. Total Number of Records on File []		
6. Year/Quarter on File (YYYY/Q) 1. [] 2. [] 3. [] 4. [] 5. []	7. Record Count by Quarter 1. [] 2. [] 3. [] 4. [] 5. []	8. Deletes [] 9. Predecessor/Successor Records []
10. Mode of Transmittal <input type="checkbox"/> Service Center at DMA <input type="checkbox"/> EUSWeb <input type="checkbox"/> Other (Specify): []		
11. Date of Last UI Extract Load (MM/DD/YYYY) []	12. Date of Last Micro or Integrated Edit Run (MM/DD/YYYY) []	13. Date of Last Estimation/Imputation Run (MM/DD/YYYY) []
14. Remarks (Dataset Names Are Not Necessary) []		
15. State Technical Contact Name []	16. State Technical Contact Information Phone: [] Email: []	

Technical Contact, Division of Business Establishment Systems: Supervisor, QCEW Systems Development June 2019

Voice: (202) 691-5234
 Fax: (202) 691-7292
 E-Mail: EQUI_Submittals@bls.gov

12.4 Sending Test Files When Making System Changes

The national office strongly recommends that test EQUI files be submitted to the national office several weeks in advance of the deliverable whenever a state implements a new processing system or makes a major change to an existing processing system. (Making a normal version change, such as changing EXPO or WIN, would not be considered a major change and would not require a test tape.) A major change to the state's UI Extract process or a major change to the UI Tax system such as from a UI Modernization would warrant test files.

The reason for the submittal of the test file is to determine if the new or changed processing system adversely affects the deliverable so that any identified problems can be corrected before the deliverable is submitted. Early identification of problems will make it more likely that corrective action can be taken before the actual QCEW data are needed for tabulation. The test files will not be stored on the databases at the national office, and corrections will not be processed against the test files.

The test file must contain all regular data elements so that it may be properly screened by the BLS EQUI processing system.

The regional office should notify the national office of any changes in the state's processing that might require the submittal of a test file and of the date and method of transmittal of this file.

12.5 File Retention

State systems provide the means for states to easily archive and retain EQUI files as well as other files, including the oldest quarters of data that "roll off" the Micro file and the Macro file.

It is essential that states keep a copy of every EQUI file sent to BLS, whether it is the quarterly deliverable or a correction file. This is because EQUI files can be lost or damaged in transmission and may need to be replaced. State systems will generate correction records by identifying all changes made to the data since the last EQUI file was generated. However, this tracking of data changes can be thrown off if the previous file was lost and needs to be replaced. Therefore, lost files should be replaced from backup copies, so state systems are not called upon to generate EQUI records a second time for data that were only changed once.

Current: BLS requires the following retention of files by the states:

- EQUI: retain in machine-readable form for a minimum of three years.
- ARS Control file: retained until after completion of the next cycle for the same portion of the universe. Presently, this is five years.
- Micro Files: retain in machine-readable form for a minimum of 3 years after submittal of data to BLS. It is recommended that states retain this indefinitely.
- QCEW macro data: retain indefinitely (publications)

BLS continues to retain data indefinitely.

Chapter 13 – BLS Processing of the EQUI Data

The Enhanced Quarterly Unemployment Insurance (EQUI) file is the primary quarterly deliverable states send to BLS. It is the source of all data the QCEW program publishes and provides to data users. This chapter describes how BLS processes EQUI files, and gives particular emphasis to printed output. Also covered are correction procedures and BLS data estimation for late files.

----- Contents of Chapter 13 -----

- 13.1 Overview of BLS Processing
 - 13.1.1 BLS Micro File
 - 13.1.2 Normal BLS Processing of EQUI Files
 - 13.1.3 Macro Data for Key Users and Publication
 - 13.1.4 Locking Out Data Changes for Older Quarters
 - 13.1.5 Special Processing to Ensure Consistent, Accurate Data
- 13.2 Output from BLS Processing
 - 13.2.1 BLS Pre-edits the Data
 - 13.2.2 EQUI Counts and Information
 - 13.2.3 EQUI Edit Listings
 - 13.2.4 EQUI Management Information Spreadsheets
- 13.3 BLS Review and State Correction Procedures
 - 13.3.1 BLS Review Activity
 - 13.3.2 State Correction Activity
 - 13.3.3 Edit Priorities
 - 13.3.4 Subset File
 - 13.3.5 Clean Declaration/Quarterly Signoff
- 13.4 BLS Estimates for Late Files

13.1 Overview of BLS Processing

Under policies in place since the EQUI file became the standard deliverable, all data entry, updates, and corrections occur only at the micro level and usually only in the states. All data for any BLS-open quarter that are loaded or entered onto the state micro file through a standard state system (EXPO or WIN-202) are provided to BLS on EQUI files. The BLS micro file database, built from the EQUI files, should have the same or virtually the same data as the states, at least for recent unlocked quarters.

The following sections outline the national office's role in the QCEW program. The full processing flow of the program is diagrammed and described in Section 1.5, Overview of Quarterly and Annual Processing. The latter part of the flow chart in Section 1.5.1 illustrates the processing described in this chapter.

13.1.1 BLS Micro File

The BLS system, similar to the standard state systems, uses a database called the micro file. All data on the BLS micro file are loaded from EQUI files and all EQUI data elements are present on the BLS micro file. The micro file contains a number of non-quarterly data elements that occur only once, including:

- Key fields (State FIPS Code, Unemployment Insurance (UI) Account Number, and Reporting Unit Number (RUN))
- Predecessor and successor UI Account Numbers and RUNs
- Name and address fields
- Employer Identification Number (EIN)
- Date fields (Initial Liability, End of Liability, Setup, and Reactivation dates)
- Annual Refiling Survey (ARS) related fields such as Response Code, ARS Year, and Old Code fields
- Geocoding fields such as latitude and longitude
- Facts of discrepancy fields such as fact of discrepancy NAICS
- Other codes and indicators such as organization type, data source, and version fields (administrative, quarterly)

The BLS micro file contains seven identically structured blocks of quarterly data elements, beginning with the current processing quarter and extending six quarters back. BLS does not use a future quarter. Quarterly data elements include:

- Economic data (monthly employment, total wages, taxable wages, contributions)
- Indicator flags (imputation flags) for each of the economic data elements
- Classification codes (including NAICS, ownership, county, township)
- Status code
- Multi Establishment Employer Indicator (MEEI) Code

- Comment codes and the narrative comment field
- Census fields (such as Census ID)
- Class code
- Data source
- Delete identifier
- Place (city) code
- Type of coverage
- Year

The BLS database contains data for all 53 states. It actually consists of 53 mainframe computer datasets, allowing each state's data to be processed separately; however, the data are also aggregated on a national level for various purposes mentioned in Section 13.1.3. Altogether, the BLS micro file database has more than ten million records.

13.1.2 Normal BLS Processing of EQUI Files

The BLS system loads EQUI files to its micro file in a sequence of steps that generate various files as well as the listings described in Section 13.2. The output files are given to established data users (as the next section describes), loaded to the BLS Longitudinal Database (LDB), and used for publication and data dissemination. DBES provides a copy of the BLS QCEW state system for use by authorized BLS customers. Called the 7 quarter file, this resource is always synchronized to the production version of the BLS QCEW micro file.

EQUI files are processed either as primary files for the quarter or as secondary/subset files. For primary EQUI files for the quarter, the quarterly blocks of data on the micro file for that state are "rolled" before EQUI processing begins. This means that the oldest quarter is removed and archived, while each of the other quarters is shifted. The current quarter's data are moved to the block for the prior quarter, the prior quarter's data are moved to become two quarters old, and so on. A new current quarter is initialized (set to initial values) before the EQUI is loaded.

File types in chronological order:

Primary – The first EQUI file sent from the states to BLS. Primary quarterly files provide a current quarter record for every active, UI- or UCFE-covered reporting unit on the state system. Inactive and pending reporting units may be included as well. EQUI records from earlier unlocked quarters are included on the deliverable file, if the State changed the unit's data for that quarter.

Secondary – An update to the primary file. The update automatically brings in all changes made to records in the states' systems since the primary file was submitted. This file was developed during testing of one-week acceleration testing. It will be maintained as an option in WIN/EXPO for use as needed.

BLS Correction – Prior to the advent of the BLS Correction System (BCS), the subset file was the primary method for making corrections to records in error in the BLS version of QCEW after the deliverable was submitted. As of April 2017, the BCS provides BLS staff with almost all the capacity to change records that states have had since the beginning of Mic/Mac processing, one exception is the capacity to create new records or assigning predecessor/successor codes (predecessor/successor capacity is in development). BLS corrections are created in the national office by the CDA and LDB groups, as well as by regional office analysts.

Subset – Subset files include records for accounts that have been marked by state staff for inclusion in the subset. The subset had been the primary way to correct records after the deliverable had been submitted and reviewed by BLS. With the implementation of the BLS Corrections System, subsets are no longer a necessity for many states. Subsets may be requested by the CDA or LDB groups, or the regional offices. They may also be submitted by the states as they see fit.

On the BLS micro file, the initial values for the economic data fields are zero, the employment and Total Wage indicator flags are “M” (Missing), while most other quarterly data elements are set to blank. The initial values of the classification codes (primarily the industry, ownership, and county codes) are blanks, not values copied from the prior quarter. The initial values for the Status Code and the Taxable Wage indicator flag are “3” and “B,” respectively. These are special values used only in BLS.

While each micro file record contains fields for seven quarters, each EQUI record contains data for only one quarter. When an EQUI record is loaded to the BLS micro file, data from the non-quarterly EQUI fields replace the contents of the equivalent micro file fields. Data from the quarterly EQUI fields replace corresponding data in the micro file fields for the designated quarter. If the initial quarterly file does not include an EQUI record for every reporting unit (every UI/RUN) on the BLS micro file, the unmatched UI/RUNs retain their initial values on the micro file for the new quarter. If an EQUI record introduces a UI/RUN that is not already present on the micro file, a new micro file record is generated with the full set of seven quarters; however, earlier quarters will retain the initial values. When a UI/RUN associated with an edit flag is new or discontinued, these BLS initial values (including Activity Status 3) can appear on edit listings such as the Integrated Macro Edit (Table 9A).

For an EQUI correction file, the corresponding quarter of data will already be present on the BLS micro file. Note: EQUI correction files refers to any type of file subsequent to the primary file including update, BLS Correction and subset files. When the EQUI record matches a record on the micro file, the EQUI data will replace the micro file data. Both primary EQUI files and correction files normally include records for more than one quarter. The BLS system separates the EQUI records by quarter so records for the prior quarter are treated like correction/update records.

Every EQUI file is processed through the pre-edit (described in Section 13.2.1) to verify that the data meet minimum standards. If the number of pre-edit errors is not excessive, the EQUI data are loaded to the BLS micro file. Micro file records are then edited. The full, integrated edit, including both micro and macro edits, is always performed whenever any EQUI file is loaded.

This means that the BLS macro file (discussed in Chapter 10) is regenerated each time. Editing is always performed as a batch job.

States can run all edits run by BLS. Only one set of edit parameters and tolerances is maintained in the standard state systems. This set is used to edit all historical quarter changes, current quarter data, and subsequent quarters of data until such time as the state modifies the parameter and tolerance values and settings. The current set of parameters/tolerances is copied to the header record each time the state system generates an EQUI file.

The BLS system uses its own set of parameters and tolerances when editing. The BLS parameters are never tighter than those of the state unless the state has set theirs to levels looser than the default values (that is, above levels acceptable to BLS). BLS parameters are always looser than or equal to default parameters. BLS parameters are set in line with how the data are used and released as well as to resolve problems before questions are received from other users (for example, Bureau of Economic Analysis (BEA)). Appendix H provides a summary of the edit parameters and tolerances.

The BLS micro file includes an edit indicator for each micro edit that shows whether the record passed or failed. This means that the results of the most recent edit run are stored on the micro file. As with the other data elements, edit indicators are either administrative (occurring only once on the file) or quarterly (occurring seven times, once in each quarterly block). When the primary quarterly EQUI file is processed, the entire micro file is edited. For correction files, however, the system only edits micro records that are updated. The quarterly micro edits are only performed on the quarters of those records that are updated. Meanwhile, the macro edits are always performed on the entire file for all quarters. Additional information about editing appears in Section 13.2.3.

The LDB is loaded with current quarter and back quarter data from the QCEW micro file after EQUI review signoff by BLS. The LDB uses the BLS QCEW production micro file for new records created for non-current quarters.

13.1.3 Macro Data for Key Users and Publication

BLS provides files of aggregated economic data to established users as soon as state files and BLS corrections are processed by BLS QCEW systems. In some cases, the data levels are consistent with the BLS macro file although some users require different levels of aggregation or additional data elements.

Essential data users include the following:

- The Bureau of Economic Analysis (BEA) of the Department of Commerce. BEA receives macro data for each state at the county-ownership-industry level and state data totals by ownership. BEA also receives information about comment codes, noneconomic code changes, and significant data changes occurring during the cleanup

period. If a state does not agree to share microdata with BEA, BEA receives comment code and noneconomic code change information for that state in aggregate rather than microdata form. States may choose to provide BEA with no microdata, limited microdata relating to comment codes and noneconomic changes, or the full microdata file.

- The Current Employment Statistics (CES) program in the national office. CES receives aggregate employment and wage data at both state and national levels. Benchmark files include employment by industry by size class. CES also receives national Summary of Differences data showing noneconomic code changes by industry and ownership. CES has access to all live QCEW microdata via the 7quarter micro file.
- The Employment and Training Administration (ETA) of the Department of Labor. ETA receives state and national data including Taxable Wages and Contributions, broken out based on type of coverage (taxable, reimbursable, and Federal). Due to earlier submittal by states and faster BLS publication processing, ETA receives these files on BLS QCEW release day each quarter. ETA has no microdata access.

Shortly after the national review signoff, the QCEW program releases data to the public. This publication deadline limits the amount of time available for review of the quarterly deliverable. For that reason, states must deliver a quarterly deliverable that is of good quality. Refer to Appendix T for a hyperlink to the QCEW homepage, which contains more information on data releases.

13.1.4 Locking Out Data Changes for Older Quarters

The correction policy described in Section 12.2.3 describes when specific quarters of data will normally be unlocked. The BLS system, however, is able to unlock individual quarters and/or state files when there is a specific need.

The correction policy is intended to ensure that state and BLS files match for unlocked quarters. States should extract data for both the current and prior quarter data as well as any changes to non-quarterly (administrative) fields. BLS places greater emphasis on the quality of these quarters' data than on older quarters. However, BLS makes some effort to ensure that data are accurate and consistent for a full calendar year. For example, a record exists with a significant change between third quarter and fourth quarter. If the third quarter is corrected and this causes a significant difference between second and third quarter, second quarter data may need correction as well. First quarter may also need correction, since it can affect publication. Changes to the correction policy may change the quarters to be extracted.

13.1.5 Special Processing to Ensure Consistent, Accurate Data

For the most part, the features of the state systems that create normal EQUI files keep state and BLS data consistent. However, the state systems are also able to generate a special EQUI file for BLS that does not depend on changing data in the state. In very rare cases this file is used to give BLS a copy of the most current state data. This brings BLS data in line with state data immediately, without waiting for the normal deliverable or subset file. The file is a single quarter file that contains an EQUI record for every active and inactive record on the state system for a specified quarter. A single quarter file is typically used to replace a full quarter of data. The previous version of the data is typically removed from the BLS database and then the new version of the data is loaded.

BLS has found it efficient to directly enter corrections to issues arising from BLS review. Direct corrections are preferable to making these corrections via the processing of a subset from the state. BLS review staff make these changes to the BLS copy of the QCEW file using the BLS Correction System or BCS. These corrections are usually based on information received from the states during the review process. On occasion, data must be corrected on the BLS micro file immediately, without waiting for an answer from the state. BLS provides notice to the state regarding the content of BLS corrections. Meanwhile, the state should also enter the correction on its own state system, otherwise the inaccurate data may be reported to BLS again on a subsequent EQUI submittal.

Subsets are almost always not needed to complete BLS correction processing. They can be submitted by states if desired.

Regarding consistency, it is worth noting that there is no QCEW program requirement that BLS and state files and outputs be identical. For example, states can keep working on quarters that are locked at BLS. BLS creates measures of change adjusted for breakouts and code changes. These are not available from Win and Expo. States publish township-based totals in New England, while BLS publishes by county in all states. States can create special industry or area groupings not used at BLS. Even with these differences, both versions are usually telling the same economic story.

13.2 Output from BLS Processing

The EQUI format is used to send all appropriate micro level data from the state system to the national office, including initially submitted current quarter data, retroactive back quarter data, corrections or other updates, deletion records, and certain inactive records. When a normal EQUI data record is submitted for a given quarter, all data elements – quarterly and administrative – are included. (Appendix K shows the EQUI formats.) When the national office processes EQUI files, it generates data files for established users. It also generates extensive listing output including data element counts, edit listings, edit counts, and data summaries. Some version of the listing output is generated upon the processing of primary or secondary EQUI files, subset files and BLS Correction files. Some information listed on the EQUI output tables

is confidential, therefore wording in the header is provided on the necessary listings to indicate the confidential nature of the data.

The national office will notify the state and regional offices via Email when output is available to view and/or print in their office. The email notifications include links to a pdf document that contains the entire edit output report. Also included are links to rtf files for each individual table. It is important to use links when sending the listings to the regions and the states to prevent the unauthorized disclosure of confidential data.

13.2.1 BLS Pre-edits the Data

Once a state's EQUI file is received and ready to process by BLS, the records are sorted. The header record is read to identify the state's edit parameters. The trailer record is read to identify data totals included on the submittal. The trailer record totals (generated by the state processing system as it created the file) are compared to load totals (generated by the BLS system as it reads the file) to ensure that the files remain consistent. This comparison helps identify whether some records may not have been read, or were dropped.

The states are to submit a transmittal sheet via email to EQUI_Submittals once they submit the EQUI file (see Chapter 12). DBES compares the record counts on the transmittal sheet to the file sent by the state. DBES reaches out to the state via the regional office regarding any discrepancies. If the counts don't match, DBES will not process the file until the two are reconciled.

The EQUI data records for all quarters on the file are processed through a pre-edit. The pre-edit identifies serious errors prior to running the full edits. If the number of pre-edit failures is not unreasonable, the EQUI data are loaded to the BLS micro file. Then full editing and other processing continues, as described in the following two sections.

The following tables are printed in these early stages of BLS processing on both primary and correction runs.

Table 1A - Comparison of EQUI Totals to Data Reported on the Trailer Record

This listing compares the record counts, economic data, and delete totals reported on the trailer record to those calculated by the BLS system. If data differences appear for the counts of the entire file (all quarters), this may indicate that BLS was not able to read all the records that should be present. See EXHIBIT 13A at the end of this chapter for an example of the report.

Table 1B – EQUI Pre-Edit Error Summary Counts

This report shows the number of records flagged on the EQUI Pre-Edit Listing. If the number of records with pre-edit errors exceeds a parameter (typically 1,000), processing will stop and the data will not be loaded to the BLS micro file. The national office will then contact the regional office about how to proceed. See EXHIBIT 13B at the end of this chapter for a sample page of the report.

Table 1C – EQUI Pre-Edit Listing

This listing displays the records that fail the following edit conditions as well as for non-numeric employment or wages. The edit conditions include all of the Level 1 edits, plus selected edits from Levels 2-4 that identify critical errors affecting data aggregation and key data users such as CES and BEA. See EXHIBIT 13C at the end of this chapter for a sample page of the report.

Level 1 – Pre-edits

- 001-I Invalid Transaction Code
- 002-I Invalid UI Account Number
- 003-I Invalid Reporting Unit Number
- 004-I Invalid Reference Year
- 005-I Invalid Reference Quarter
- 006-I Invalid State Code

Level 2 – Key Field edits

- 010-I Invalid NAICS Code
- 012-I Invalid Ownership Code
- 013-I Invalid County Code

Level 3 – Date and Status Code Edits

- 025-I Invalid Status Code

Level 4 – Remaining Invalid Error Edits

- 040-I Invalid MEEI Code

The pre-edit output should be the primary vehicle for identifying the rare case of non-numeric employment or wages, as they might not be displayed on Table 9B. Records with non-numeric employment and wages will be loaded to the database with the non-numeric fields zero-filled. Typically, states must submit an update transaction for every record on Table 1C. However, states may choose to focus on edit codes 001-006 when reviewing this pre-edit listing, since the other edit codes (010-013, 025, and 040) will also appear on the Micro Edits Only listing (Table 9B). Level 1 errors (001-006) are not displayed on Table 9B. All of the edit conditions, including those above, are described in detail in Appendix F.

13.2.2 EQUI Counts and Information

BLS generates numerous counts that provide significant information about individual data elements or combinations of elements. These counts are also included in the EQUI edit output as Table 3 and Table 8 counts, parameters, and other information are also written to files in national office and used in various spreadsheets.

The following informational tables print on the EQUI edit output. Some of these listings will only be generated when a full (primary or secondary) EQUI is run; others will be generated for initial, update, BLS Correction and subset runs. The table is printed on all versions of EQUI edit output unless otherwise noted in parentheses next to the table names. Not discussed here are the

CCS Tables generated during first and second quarter processing. Those listings appear in Section 11.7.

Table 2A - State Totals

This report provides state ownership totals by quarter for average monthly employment, average weekly wages, the number of establishments (reporting units), monthly employment, total wages, taxable wages, and contributions for the current and seven previous quarters.

This report excludes data from master records (records with MEEI 2 or County 900), inactive or pending records (Status Code not 1), non-covered records (Type of Coverage Code 8), and records without a valid Ownership (Code is not 1, 2, 3, or 5). The Over-the-Quarter (OTQ) and Over-the-Year (OTY) percent changes are included as analytical tools to facilitate data review. This high level summary can be used to quickly identify significant changes in state total data from one quarter to the next, or in the current quarter compared with the same quarter of the previous year. See EXHIBIT 13D at the end of this chapter for a sample page.

Table 2B - County Summary

Table 2B focuses on OTY data comparisons and has three sections. A summary of the table appears first. This summary lists the percentage changes in third month employment and average weekly wages by county. Columns marked as "T Adj" contain adjusted totals, which exclude data from records with publication error flags. Columns marked with "T" contain the unadjusted totals. See the discussion on Table 9X for a complete list of the publication edits.

The summary section is followed by a section of detailed employment and wage data for each county broken out by ownership. Over-the-year changes are given as a percent and as a level for third month employment, average weekly wage, total wages, and average monthly employment. Also provided are the average annual employment and the average annual wage, compared to a 4-quarter moving average for the current year-to-date. This is shown in the upper left hand corner of each county ownership breakout.

A final section provides statewide totals broken out by ownership.

The purpose of this table is to identify and review large fluctuations within a county that may impact publication. Annual averages and comparisons can provide early warning of these fluctuations, which might otherwise go undetected from the macro cell-level review and the industry-based editing and data review tools. Analysts can target problem counties for more detailed review.

Table 2B can also provide warning of systematic problems. It should be used to identify very large and suspicious data movements in the primary run and to review changes to county-level employment and wages in update and other submittals, as needed. Very large movements in the current quarter's data that are not explained by seasonality or code changes should be investigated further. The listing may also be used to monitor the annual data and, during first quarter processing, to identify unexpected changes between the preliminary and final publication data for the previous year. Review Table 2B generated from secondary runs only to the extent that large changes to the data are made, which are listed in Table 13A. See EXHIBIT 13E at the end of this chapter for a sample of Table 2B.

Table 3 – EQUI Data Counts

This report is used to review the reporting level of many data elements, such as employment and wages indicator flags, address information, and various codes. Along with the number of edit flags (see Table 8), these data element counts are also indicators of data quality. The counts are for active non-master records, except where footnotes indicate otherwise. See EXHIBIT 13F at the end of this chapter for a sample.

Based on these counts, the national office provides feedback through the regional offices about each state's deliverable. This feedback points out increased data quality (such as a decline in the use of NAICS 999999 or an increase in the proportion of employment data that are reported and not imputed). Also emphasized are unusual data patterns or areas needing improvement (for example, a significant percentage of continuous units having county code 999, or physical location addresses that appear on the file at a level well below the national average).

Record counts for each data element are displayed in Table 3 as follows:

- Current quarter totals
- Percent of current quarter total records
- Previous quarter totals
- Percent change between the previous and current quarters

A corresponding total of third month employment is also displayed for most data elements. Total wages is substituted for third month employment for select data elements. Similar to the record counts, third month employment totals for each data element are displayed as follows:

- Current quarter totals
- Percent of current quarter total records
- Previous quarter totals
- Percent change between the previous and current quarters

Section 1 displays characteristics by MEEI code; including counts of continuous units, dropped records, and new records. Continuous units are records reported and active under the same UI account number and reporting unit number (RUN) in both the current quarter and the prior quarter. Dropped records are UI/RUNs that were present and active in the prior quarter but not the current quarter. New records are UI/RUNs that are present and active this quarter but not in the prior quarter.

Section 2 displays the following identification information and characteristics:

Predecessor/Successor	Dates
NAICS	ARS Year and Response Codes
SIC	CES Indicator
Data Source (EDI Center)	Comments
Location	Special Indicator
Ownership	Agent Code

Employer Identification Number (EIN)

Note that SIC 4-Digit Coding Exceptions, Auxiliary, and Reporting Change Indicator identification characteristics are no longer displayed as headings in Table 3. EXHIBIT 13F still includes these. This may be corrected in a future exhibit.

a) Industry Codes (Includes NAICS and SIC) – Shows a count and percentage of records carrying NAICS and SIC industry codes (SIC codes are no longer used or updated, these counts should not be used for any purpose.) The various record counts are grouped by industry code. Some of the groupings common across the industry codes are listed below:

- Records with valid/specific codes (excluding 999999)
- Records with 999999
- Month 3 employment

b) Location Codes – Shows a count and percentage (with month three employment) of records having valid, specific County codes. There are separate counts and percentages for each of the county equivalent codes:

- 995/999 (combined)
- 995 (statewide/multi-county)
- 996 (foreign)
- 998 (out of state)
- 999 (unknown)
- 900 (master records)

c) Date Fields – Shows counts and percentages of records reporting each of the EQUI dates:

- Set-up Date
- Initial Liability Date
- End of Liability Date
- Reactivation Date.

The Date portion of Section 2 also shows a count and percentage of records having both an End of Liability Date and a Reactivation date, with (1) the Reactivation Date later than the End of Liability Date and (2) with the End of Liability Date later than the Reactivation Date.

d) ARS Information – Shows a count and percentage of records with a non-blank ARS Year and numeric response code.

It also shows a count and percentage for selected values of the ARS Response Code: 41, 42, 46, 50, 63, 64, 65, and 98.

e) Comment Codes – This part of Section 2 lists separate counts and percentages of records with one, two, and three numeric comment codes. Also, there is a count and percentage of records with non-blank narrative comments.

f) *Agent Codes* – Shows counts and percentages for records with a non-blank value in the Agent Code field. It also includes month 3 employment totals.

Section 3 displays employment and wage information including summaries of month three employment and total wages reported, imputed, missing, and prorated. It provides detailed record counts, employment and wage indicator counts, and employment for each value of the employment indicator flag, broken out by ownership and by month. Detailed record counts and total wages are provided for each value of the total wages indicator flag. Employment and total wage indicator flags are identified and discussed in Appendix J.

Section 4 displays information about addresses and related fields. Separate counts and percentages are given of records with Physical Location (PL) address fields, non-blank UI address fields, and non-blank Mailing/Other address fields. Record counts by MEEI groupings appear under the reporting unit description heading.

The count for # RECS WITH MEEI 3 OR 5 WITH BLANK RUD & a BLANK PL ADDRESS includes records that have a blank city field or a PLA edit flag (i.e., edit 102, 103, 104, or 114). The system checks for records that have a blank city field since an existing PLA must have a city while a single line for the street address sometimes appears on line 2 rather than on line 1. Furthermore, even if a PLA does exist on a record, the system also checks whether the PLA is valid by checking for edits 102, 103, 104, or 114.

Section 5 displays summary counts of continuous units, with detail about records that changed MEEI, NAICS, SIC, County, or other codes. Under the county code heading the "valid county" appearing on the count for # RECS CHGD FROM VALID COUNTY TO ANOTHER VALID COUNTY, does not include county 99x codes.

Section 6 provides record counts by third month employment broken out by size class for private continuous records, excluding masters for the following categories:

- All private continuous records
- All private continuous subunits
- NAICS 999999
- SIC 9999
- County Code 999
- Zero-filled EIN
- Valid Physical Location Address (PLA)
- Subunits (MEEI 3 or 5) with Reporting Unit Description (RUD)
- Subunits (MEEI 3 or 5) with no RUD nor valid PLA

Most of the percentages listed in Section 6 are based on the respective size class for total private continuous records as opposed to the total for each category. In addition, employment totals for each address data element and counts for valid address blocks are included in the listing. (Valid address blocks are defined as records with non-blank addresses that do not have any of the address-related edit flags.)

Section 6 of Table 3 is used in the generation of the QCEW Quality and Performance Measures report ("Flash Report"). The "Flash Report" is a report generated by the national office and posted on the StateWeb that provides various quarterly performance measures.

Section 7 displays summary counts of new units, giving some characteristics about MEEI, NAICS, County Code, and EIN.

Section 8 reflects the geocodes (based on PLAs) supplied through the previous quarter, assigned in the national office, loaded to state files, and provided back to the national office in the current quarter's EQUI files. These counts do not reflect any improvements the state may have made to the PLAs in the current quarter. Those changes will be reflected on the following quarter's EQUI after new geocode files have been provided by the national office and loaded to the state systems.

Table 4A - EIN Matrix Map

This listing specifies the number of times that a given character is used in each position of the EIN field for all active, covered records including masters. See EXHIBIT 13G at the end of this chapter or a sample.

Table 4B - UI Number Matrix Map

This listing specifies the number of times that a given character is used in each position of the UI Account Number field for all active, covered records including masters. See EXHIBIT 13H at the end of this chapter or a sample.

Table 4C - RUN Matrix Map

This listing specifies the number of times that a given character is used in each position of the Reporting Unit Number field for all active, covered records including masters. See EXHIBIT 13I at the end of this chapter for a sample.

Table 6 - Record Counts by Valid County/Township Codes

This table lists counts of the number of records reported in each valid county (and township for states required to use them) for active, non-master records. See EXHIBIT 13M at the end of this chapter for a sample page.

Table 15 - Comment Codes and Narrative Comments

This listing provides detailed information on comment code usage, including counts for each code used as well as various percentages. See EXHIBIT 13Z at the end of this chapter for a sample.

Table 16 - EQUI Sample Records (primary only)

This listing provides a sample of approximately 300 records from the state's EQUI file in a three-records-per-page format (so they are a sampling of the whole file from beginning to end). A review of this listing can sometimes uncover systematic data problems. Particular attention should be given to the area of physical location addresses because of the growing importance of

geocoding. If there are high levels of edit 114 (physical address error), the sample listing could be used to provide examples. See EXHIBIT 13AA at the end of this chapter for a sample page.

13.2.3 EQUI Edit Listings

BLS generates several tables to identify flagged records and summarize edit results. Like the EQUI Counts listings described in 13.2.2 some listings will only be generated when a full (initial) EQUI deliverable is run; others will be generated for all runs. Listings are provided for all edit run unless otherwise noted in parentheses next to the table names. See Appendix F to view the edit specifications for all the required edits used in the standard state QCEW processing systems and in the BLS system.

Table 7 - Edit Parameter and Tolerance Listing

This listing provides the edit parameters and tolerances used by the state (as provided on the EQUI header record) and those used by BLS. The "State Parameter Values" column reflects values included on the EQUI header record. If a particular value does not exist on the header record, the corresponding field on the report will be blank. The "BLS Parameter Values" in the last column show the actual values used to edit the data and generate Tables 8-10. At the end, Table 7 displays the BLS print cutoff parameters used for generating Table 9B. See EXHIBIT 13N at the end of this chapter for a sample page of Table 7.

Table 8 - Edit Code Summary

This report lists multi-unit discrepancy counts and the number of records that failed each edit (both micro and macro) for the current quarter, the prior quarter, and all other back quarters. Each edit run generates a set of counts that identifies how many times an edit condition occurred along with the edit code and the edit message. See EXHIBIT 13O at the end of this chapter for a sample.

The counts on this table may not always be consistent with the records printed on Tables 9A and 9B. For example, some employment and wage W-flags on micro records that do not cause a macro record to flag will not be printed. W-flags in this category that are not significant enough to cause the macro cell to flag on Table 9A will not print on Table 9A, and they will not print on Table 9B. In addition, records exceeding the Table 9B print cutoff will continue to be flagged and counted on Table 8, but they will not be printed on Table 9B.

Table 9A – Integrated Macro Edit

The purpose of this table is to review macro cells with significant current quarter changes in employment or wages. Regional offices should review this listing to identify significant or suspicious macro employment and wage data changes so the state can explain or provide micro-level corrections if necessary. The Over the Quarter (OTQ) and Over the Year (OTY) percent changes for the macro cells and level changes for the micro records are included as analytical tools to help determine if there is an issue with the record listed on the tables. It is essential that Table 9A be reviewed in its entirety from the deliverable run so that all current quarter macro edit failures are examined at least once. In particular, macro records flagged with edit codes

091-094 and 135 should be reviewed carefully. This listing shows all macro record edit failures for the current quarter - that is, the flags assigned to County/Ownership/NAICS macro cells. There may be some instances where there are no associated micro record edit flags, so only the macro record will appear. For current quarter failed records, Table 9A along with Table 13B could be used to review the entire macro record and any accompanying micro records that might explain the data. See EXHIBIT 13P at the end of this chapter for a sample page.

A print cutoff was incorporated for Table 9A that is designed to prevent the printing of immensely large listings caused by large numbers of micro records printing for macro cells. The number of micro records being printed for a particular macro cell will be limited to a specified parameter. A message will print at the end of the cell if the parameter is exceeded.

The macro records are sorted by County, Ownership, and industry code. Below each macro record, are the associated micro records that have the corresponding edit flags, with supporting data including the micro comments. Economic data for the macro record are shown for the current quarter and the seven previous quarters. The micro data appear for the current quarter and six previous quarters. Included are the economic data, classification codes, and other essential quarterly data elements such as Activity Status (ST), MEEI (ME), and Ownership (OW). Over-the-quarter (OTQ) and over-the-year (OTY) changes in average monthly employment and average weekly wages are included in the state systems. The employment and wage numbers on the micro data records are followed immediately by the employment or wage indicator flags, to show whether the data were reported, imputed, prorated, and so on.

Records with more serious macro employment and wage flags are the following Level 5 edits:

- 091-W Employment Change Greatly Exceeds Test Parameters
- 092-W AQW Change Is Significantly > Parameter and Exceeds Twice the Quartile AQW Range
- 093-W Average Employment Is Significantly > parameter, but Total Wages = 0
- 094-W Average Employment = 0, but Total Wages Is Significantly > Parameter

The other edit flags that may appear on this listing are these Level 6 edits:

- 126-W Employment Change Exceeds Test Parameters
- 127-W AQW Change > parameter and Exceeds Twice the Quartile AQW Range
- 130-W Average Employment > parameter, but Total Wages = 0
- 131-W Average Employment = 0, but Total Wages > parameter
- 134-W Number of Establishments Out Of Range
- 135-W New or Discontinued Record

Table 9A focuses on fluctuations in current quarter economic data; however, edit messages for other flags may also appear – provided that the macro cell for the current quarter is flagged. Specifically, Table 9A may show edit messages:

- For the same set of flags if they occur in back quarters
- For other micro edit flags in Levels 2-6. These will also appear on Table 9B.

During first and second quarter processing, Table 9A reflects an editing adjustment based on noneconomic code changes. This process, called code change integration, uses data from the Summary of Differences file to temporarily adjust macro data (monthly employment, total wages, and number of units) as they are edited. (See Section 11.6 for more information.) If Summary of Differences data account for any data fluctuations, the macro cell does not flag and is not listed on Table 9A. If Summary of Differences data exist for the cell but do not prevent edit flags, these data appear on Table 9A below the macro edit codes/messages. All data shown on the listing for the macro cell (and for associated micro records) are the actual, unadjusted data existing on BLS files.

Table 9A-D is a subset of Table 9A. If Table 9A is reviewed, then Table 9A-D need not be reviewed. The criteria for macro cells printed on Table 9A-D is as follows:

- For all small (non-publication) counties, only print macro cells involving a change of 900 or more employees and/or \$9 million in wages.
- For large (publication) counties with average annual employment levels 500,000 and above, only print macro cells involving a change of 450 or more employees and/or \$5 million in wages.
- For large (publication) counties with average annual employment levels between 170,000 and 499,999, only print macro cells involving a change of 250 or more employees and/or \$4 million in wages.
- For large (publication) counties with average annual employment levels of 169,999 or less, only print macro cells involving a change of 200 or more employees and/or \$3 million in wages.

Table 9B - Micro Edits Only

All current quarter I-errors (except for edit codes 001-006) not displayed on Table 9X will appear on this listing. This means that any I-errors displayed on the Integrated Macro Edit listing (Table 9A) will also be displayed on Table 9B. Table 9B and Table 9X should be the primary tool for identifying and correcting I-errors (010-080). Warning flags are also included on this listing for review and correction or verification as needed. Similar to I-errors, these may not appear on Table 9B if the record has large employment and a publication edit flag. They will be displayed on Table 9X instead. These records will be sorted primarily in ascending order by edit code (putting I-errors at the top for multiple flags) with a secondary sort by ascending UI/RUN. See EXHIBIT 13Q at the end of this chapter for a sample page of Table 9B.

This listing is formatted like the bottom (micro) portion of Table 9A. It shows economic data, classification codes, and other codes for the current quarter and the five previous quarters. It also shows name and address fields and most other non-quarterly data.

A print cutoff prevents the printing of extremely large listings in cases where there are widespread errors. When the number of records being printed for a particular edit flag reaches a specified parameter, additional records with that edit flag will generally not be printed on Table

9B. (An exception occurs if a record is flagged for more than one edit code and if one of the edit codes has not yet been printed above the parameter – in that case the record will still print on Table 9B.) Parameter values can be set for each edit level (2-6).

Table 9D – Micro Deletes Only

Table 9D should be reviewed to ensure that micro records with employment greater than 100 that were intended as a "delete" were correctly marked for deletion and are now appropriately inactivated (e.g., a duplicate account). Records on this table are sorted by prior quarter month 3 employment in descending order for all open quarters. See EXHIBIT 13R at the end of this chapter for a sample page of the report.

Table 9G- Unusable Physical Location Addresses

Table 9G displays records flagged for edit 088 (Large Record without Usable PLA); it also displays any other PLA edit messages for these records. In addition to displaying the address information, various identifier and contact information is provided. The records are sorted by UI/RUN in ascending order. This listing is only included with primary edit output. Addressing the records on this table should help states meet the geocoding PLA requirements in the LMI Cooperative Agreement. See EXHIBIT 13S at the end of this chapter for a sample page of the report. See Appendix V for the current geocoding requirements.

Table 9M-EMP – Large Master Record Edit

This listing contains large master records failing employment edits (91, 94, 96, and 97) that may not be listed on Table 10 or Table 9A. The purpose of this table is to allow for the review of large master records that may be in balance with the subunits but have significant fluctuations in employment where employment is spread out among many industries and counties. The table is sorted by the largest AME in descending order for all open quarters and one quarter back from the earliest open quarter. Economic data for the micro record are shown for the current quarter and the six previous quarters. Included are the economic data, classification codes, and other essential quarterly data elements such as Activity Status (ST), MEEI (ME), and Ownership (OW) codes. The listing also includes over the year (OTY) changes and over the quarter (OTQ) changes in AME and AWW; unit tallies (UT) – the number of active worksites; and EDI tallies (ET) -- the number of EDI reports (records with Data Source = C or E). Records showing significant changes in employment should be researched further. **Quick resolution of these problems is necessary to meet quarterly publication deadlines.** See EXHIBIT 13T at the end of this chapter for an example of this table.

Table 9P - Predecessor/Successor Edit Listing

Table 9P identifies those records with employment greater than 250 failing the predecessor/successor edits (edit codes 156, 157, 159, 160, 161, and 164). Current and prior quarter employment/wages information along with applicable administrative data are shown for the predecessor and successor records. The listing is sorted by the successor ownership, NAICS, and county codes as well as the successor UI number in ascending order. Discrepancies shown on this listing should be reviewed and corrected where necessary. Corrections may include changing administrative codes (NAICS, ownership, county, or township), economic data, or the predecessor/successor links themselves. See EXHIBIT 13U at the end of this chapter for an example of this table.

Table 9X – Records Failing NAICS Publication Standards Table 9X is used to identify records failing the NAICS publication edits as well as to address any non-publication edit flags on records also having a publication edit flag. In other words, these are records that will be entirely excluded from publications unless their data are fixed. Economic data for the micro record are shown for the current quarter and five previous quarters. Records with significant employment or wages should be marked for correction. Records failing special conditions are listed first, followed by those failing publication edits. This listing only prints records having large employment, and the entire listing should be reviewed, as some records with smaller third month employment in the most recent quarter might have larger employment and wages with errors in previous quarters. **Quick resolution of these problems is necessary to meet quarterly publication deadlines.** See EXHIBIT 13V at the end of this chapter for a sample page of the report.

NAICS Publication Edits

Edit Code	Edit Name
010	NAICS Code Check
012	Ownership (OWN) Code Check
013	County (CNTY) Code Check
016	Ownership/NAICS Conflict
025	Status Code Check
031	First Month Employment (M1) Check
032	Second Month Employment (M2) Check
033	Third Month Employment (M3) Check
034	Total Wages (TW) Check
035	Taxable Wages (TAXW) Check
036	Contributions (CTB) Check
039	Type of Coverage Check
040	MEEI Code Check
056	Federal/Type of Coverage Check
057	Federal/Taxable Wage Check
058	Federal/Contributions Check
059	Coverage/Taxable Wage Check
060	Coverage/Contributions Check

Table 10 - Multi-Establishment Edit Listing

The purpose of this table is to identify and correct multi-establishment accounts that fail Level 8 edits (edit codes 171-185). This table is an essential editing tool that can expedite finding the source of large employment and wage errors due to erroneous MEEI and/or status codes. These erroneous MEEI and/or status codes cause employment and wage data to either be double counted or eliminated from the macro aggregation. Please note that if the total wages are in error, taxable wages and/or contributions may also need to be corrected even though they do not appear on the edit output. Also displayed on this listing are other multi-establishment account edit failures (Level 8) such as the additivity balance checks (employment or wages differ

between the master and the subunits). These edit flags will not appear on the other edit listings. See EXHIBIT 13W at the end of this chapter for a sample page.

Multi-unit accounts will be printed if a multi edit flag exists in either the current quarter, prior quarter, or both quarters. When the number of subunits being printed for a particular multi account reaches a specified parameter, additional subunits for that account will not be printed. A message will be displayed indicating the parameter has been reached. The sum of the worksites and the net difference lines for both quarters will be printed for all edits except edit code 179 (worksites without master account check).

The master unit's predecessor/successor UI account number is located on the top line. If the master's predecessor and successor information exist, only the successor UI will print. An "S" or "P" will appear at the end of the "PRED/SUCC:" field to indicate whether it is the successor or predecessor UI account number. The multi-establishment edit counts appear on Table 8 (Edit Code Summary).

Table 13A – Macro Revisions

The purpose of this listing is to review any significant employment and wage changes that have been made to a macro cell. This table is the primary editing tool for identifying and validating current and back quarter updates to macro data resulting from micro-level corrections. Table 13A should be used to identify the macro records that failed the edits. The primary run of Table 13A includes only back quarter data that must be reviewed. It should be used to verify that questionable data left over from the previous quarter have been addressed and that no new back quarter macro errors have been introduced with the primary file. The correction runs may include current quarter records that changed in addition to the back quarter records. It is essential for regional offices to review this listing for all edit runs to identify significant or suspicious macro employment and wage data changes and for the states to explain or provide micro-level corrections. Suspicious records must be researched using Table 9A, the ES-202 Database (EDB, a client server system containing QCEW micro data from the EQUI) or EXPO/WIN. See EXHIBIT 13X at the end of this chapter for an example of this table.

Table 13A shows the macro-level impact of micro updates applied to the file. The table shows an "old" value, a "new" value, and a net difference for establishments, monthly employment, and total wages. The table is sorted by County, Ownership, and industry code. The information is displayed in year/quarter pairs or groupings in ascending order, from left to right and top to bottom. This design eliminates the printing of duplicate records on Table 13A and requires that the analyst review the table from left to right, top to bottom to find significant changes.

All current quarter records are excluded from listing on the primary run of Table 13A. However, updates to prior quarter records (such updates are included on the current quarter file) that change their employment value by more than 100 or the total wages by more than \$1 million are displayed in Table 13A.

Table 13A also displays any macro edit codes still remaining on the macro record under the footnote "EDIT CODES - REMAINING MACRO CODES AND ERROR LEVEL STATUS".

Macro level codes are displayed under "EDIT CODES." Information about the edits flagging the micro records (the micro records that comprise the macro record) appear under "ERROR LEVEL STATUS." An "Lx" (where "x" equals the level number) indicates that one or more micro records have been flagged by an edit in that level. For example, "L5 L6" indicates that one or more micro records were flagged by at least one edit in Level 5 and one edit in Level 6. A macro level code can be displayed by itself with no accompanying error level status code and vice versa. However, if there are no macro or micro errors in either that quarter or its previous quarter, only the footnote will be displayed. The footnote indicates there are large differences between quarters, but they are not flagging as errors.

Table 13B - Macro Revisions Failing Edits

This table lists the macro cells that have had large employment or wage updates and currently have a macro edit flag for any of the updated quarters. Table 13B focuses on large changes to the data that failed the macro edits. This listing is a hybrid report that essentially outputs selected records from the Table 13A but with the existing Table 9A format. The report is a listing of all macro records that appear in Table 13A **and** have a macro edit flag for any of the updated quarters. The output looks like Table 9A, with the macro data listed first and the associated micro records printed below the macro data. The Over the Quarter (OTQ) and Over the Year (OTY) percent changes for the macro cells and level changes for the micro records are included as analytical tools. This report should be reviewed in the same manner as Table 13A and for all edit runs. Since all of the records have been flagged from the macro edits, all records in this listing should be reviewed. See EXHIBIT 13Y at the end of this chapter for a sample page of the report.

13.2.4 EQUI Management Information Spreadsheets

BLS and state users should make use of the EQUI management information spreadsheets, which can be accessed via the StateWeb intranet. These spreadsheets provide a wealth of useful information about state processing and can help identify possible systemic problems or issues with the state data. Counts are available from the deliverable files, as well as from the final counts reflecting the end of the BLS review and correction period.

Deliverable Counts

The first version of the data element counts spreadsheets represents the current quarter's data once the deliverable is processed. This version takes into account both the primary and secondary files submitted by states. Normally, this processing includes the initial edit of the quarterly deliverable. Once the national office determines that a state's deliverable file is acceptable (no single quarter or revised file will be requested), then the counts from that edit are downloaded and used for calculations. The spreadsheets are produced after the primary and secondary files for every state have been processed.

Final Counts

Data element counts are also generated from subset files. If a state doesn't submit a subset, the counts are generated from the BLS correction files. These counts are downloaded and used to

produce an updated data element counts spreadsheet, which compiles the data counts from the BLS micro file at the end of the BLS review and correction period, after all subset files and BLS correction files have been processed.

Historical Counts

Record counts and associated percentages across multiple quarters for selected EQUI data elements are displayed on the historical EQUI data counts spreadsheet. Graphing ability is included. This spreadsheet offers a broad perspective that a reviewer might miss from looking at the quarterly counts alone. The historical counts are compiled from the deliverable and final EQUI data element counts spreadsheets that are prepared each quarter.

The various counts spreadsheets should be used to monitor problem areas in each state's processing of data and improve data quality.

13.3 BLS Review and State Correction Procedures

The national office works with State and regional office staff to review, verify, and publish local economic data. Quality input data are essential for the timely publication of accurate employment and wages.

BLS conducts a review and correction procedure prior to the release of QCEW publications. This process includes researching possible large errors in employment and wages that may affect the quality of the reported data. Possible large errors are researched immediately in the national office and submitted to the region for clarification and correction. Large over-the-year changes appearing in the news release are verified through the use of publication questions.

Potential errors identified by national office staff are shared with the regional offices in the form of national Office Questions (NOQs). The regional offices send NOQs to the respective state, in addition to any regional office Questions (ROQs) they may have from their own review of the file. The state responds to the NOQs and ROQs via the regional office. If a NOQ or ROQ results in a correction, the national office or the regional office may make a correction using the BLS Corrections System. Nearly all cases of errors meeting BLS criteria for a correction can be made using the BCS. One exception is correcting complicated predecessor/successor linkages. BLS-open quarter corrections made in the state will automatically be included in the next quarter's primary file.

In cases where a BLS Correction cannot be made, BLS staff may request a subset for correction of specific errors. States may also include corrections on the subset file that they feel to be significant, even if they were not requested by BLS. The national office processes BLS corrections and the subset and generates edit output and review tables. The national office then reviews, researches, and validates the revised data. Additional questions may be developed as part of this review.

Working within the processing schedule, the national office will accept the changes to the file and sign off on the economic validity of the open quarters. Regional office staff sign off on the

quality of microdata by declaring the state to be “clean.” Occasionally, the national office will make a second set of BLS Corrections to establishment records to meet deadline and quality constraints.

Processing deadlines, procedures, and criteria referenced in this section are subject to change. Please refer to the current quarterly EQUI File Processing memo (circulated via Email at the start of each quarter) for the latest information.

13.3.1 BLS Review Activity

The review of QCEW data in the national office is conducted by several different groups. The Current Data Analysis Branch (CDA) reviews employment and wage totals each quarter in support of QCEW publication activities. The Longitudinal Database micro review group (LDB group) conducts a quarterly establishment-level review. The regional offices review the mic/mac edits each quarter. BEA also submits questions to CDA during the review.

CDA Review

CDA conducts a review of employment and wages prior to the QCEW data release by BLS. This review results in NOQs that are transmitted to the states via the regional office. CDA's questions for the states are submitted at the level of the basic county-ownership-industry macro cell. These NOQs are developed when employment and/or total wages differ substantially from the expected level or do not follow historical employment and wage trends. Regional offices are expected to immediately share NOQs with the appropriate State.

CDA sends out NOQs for over-the-year changes in employment and wages using criteria which vary by state size. See the “CDA Review Criteria” table below for details. Each quarter's initial round of NOQs is sent to the regional office within ten working days after receiving the edit output. Subset NOQs are sent within one working day of receiving the subset edit output.

CDA staff works with review files built by DBES. These files are primarily built using microdata from the EQUI and are meant to serve a similar purpose to many of the BLS edit listings while more closely adhering to the review criteria established by CDA. They also use the Macro Analysis Tool (MAT), Enhanced Database (EDB), Pub-Files, and special publication review tools.

The MAT is a tool used by CDA that includes several years of employment and wage history. It helps analysts examine counties and industries with questionable economic behavior. CDA analysts then use the EDB to identify the establishments that are creating the questionable behavior.

DBES review files used heavily in CDA review consist of Macro Data Review (MDR), Macro Data Updates (MDU), High Level Macro Data, Multi-Edit File (MEF), MIC/MAC Analyzer, and Code Change Review (CCR). A NOQ may be developed by CDA when changes exceed the

criteria mentioned in the table below. Changes within these ranges that fit prevailing patterns or that match known special economic events (such as strikes) usually do not result in NOQs.

MDR files are a primary tool for CDA to review large changes in employment and wage data at the county level. The file aggregates employment and wages for each macro cell in the state and presents those cells with over-the-year changes that exceed CDA review criteria and must be evaluated. Analysts can then review micro records within the cell for unusual over-the-year changes and create NOQs if necessary.

MEF errors and significant imbalances must be corrected.

MDU files show changes (at the macro level) to any BLS-open quarter as compared to the previous version of the file at BLS. MDU files are the primary editing tool for identifying and validating current and back quarter updates to macro data resulting from micro-level corrections. The initial run of MDU includes only back quarter data that must be reviewed. The MDU listing for subsequent runs may include current quarter records that changed in addition to the back quarter records. Significant unexpected changes may lead to NOQs. CDA staff considers the size of the cell, the industry, cell history, and seasonal trends when determining if a change shown on MDU will result in a question. A change meeting the large/small state criteria may be seen on MDU but not result in a NOQ. If the change appears to be in keeping with historical reporting, the CDA analyst may deem it to be acceptable.

CCR files are used by CDA to identify large shifts in data caused by a code change to a micro records. Analysts check to see if the change is economic or non-economic and if the code change was added during the appropriate quarter. An NOQ is often required to verify such a change.

MIC/MAC publication files are generated in the CDA Branch for researching publication counties with unusual over the year change(s) in employment and/or wages. The publication files serve many different functions in the review process. The publication review supplements the traditional review of listings by checking for large counties with large over the year changes in employment or wages, adjusted for non-economic changes in the data. This review also results in NOQs, some of which come after the conclusion of the regular quarterly review.

BEA, an established user of QCEW data, sends questions to CDA throughout each processing quarter. While most BEA questions can be explained by researching the data in Washington, some cannot. These questions are also referred to the state via the regional offices.

CDA Review for Publication Adjustment

Adjusting for non-economic code changes allows the QCEW program to publish county data that mostly reflects real economic growth. Without adjusting for non-economic change, published data would contain more distortion due to reporting changes. The publication adjustment process modifies year-ago county, ownership, and/or industry codes inside the adjustment system. Examples include establishments included on the CCS, establishments previously having unclassified county or NAICS codes receiving a specific county or industry designation,

or breakouts of single employers to multi-establishment accounts. On occasion, especially in first quarter when non-economic code changes are supposed to be brought in, states will receive NOQs regarding the validity of economic/non-economic changes. Actual micro records are not modified. Macro adjusted data is an aggregation of adjusted microdata.

Effective with 2014/3 review, CDA implemented Automatic Proration Adjustment (APA). Multi-establishment accounts with comment code 48, 90, and/or 91 on any unit are automatically prorated to create year-ago matching subunits with distributions of data matching that of current quarter subunits. This adjustment can be applied to a single-to-multi breakout or to a multi with better reporting. It must be a multi in the current quarter and have a CC 48, 90, or 91 in at least one subunit. These codes were chosen because they indicate the recognition of a change in the quality and accuracy of reporting. It implies that no economic events have occurred, rather that the firm or state has a better idea of the data quality. States should be aware of the consequence of adding these codes because of the automatic nature of the process for CDA. The proration does not need to be approved, though if it causes a large shift in employment or wages between macro cells, it may result in an NOQ. The criteria for excluding some accounts with the appropriate comment codes from this adjustment process is shown below.

CDA Review Criteria				
Edit Output	Category	Employment	Wages	Focus
Gross Key punch Report		≥ 5,000	≥ \$20 million	Unusually large data problems, often due to keypunch errors. <u>Enter Key Punch Error on Gross Key Punch Report Immediately.</u>
KP (KeyPunch) File				Any record on the file meets review criteria.
High Level Data Viewer				Graphs not following trends or reflecting expected changes due to declines/upswings in the economy at ownership and supersector totals
EQUI Data Counts Imputation				Significant change in imputation and missing data for employment and wages
EDI Summary Review File		≥ 500	≥ \$5 million	Review UI_Run level records that flag for ABS employment OTY change of 500 or more, or \$5 million for wages.
Macro Data Review Tool	Small Pub CNTY ¹ ¹	≥ 300	≥ \$3 million	OTY change for current quarter
	Large Pub CNTY ² ²	≥ 500	≥ \$5 million	
	Non-Pub CNTY ³ ³	≥ 1,000	≥ \$10 million	
Largest Employer File with 9M records		≥ 1,000	≥ \$10 million	1. Review records with change in status to N (new) or R (removed). 2. Review 9M records: current quarter month-to-month change, and total wage change not within historical range. Do not research Pred/Succ issues here.

Pubfail	Small State	≥ 500	≥ \$5 million	Filter the national Publication Edit Failire (PEF) file by state FIPS, then filter the type field by "ST" (state aggregate of PEF records) and "MIC" (PEF micro records). If the state aggregate meets the small or large state criteria, include a question on the NOQ Form. Put the associated "MIC" records in a separate file on qcom in the same folder as the NOQs. Put a link in the PEF NOQ to the file of PEF records on qcom.
	Large State ⁴	≥ 1,000	≥ \$10 million	
Multi-Edit File	Small Pub CNTY	≥ 300	≥ \$3 million	For any UI accounts that are out of balance by 500 or more in employment, and/or \$5 million or more in wages, use the Error Check App (ECA) tool on the CDA Menu to see if there is a macro data impact that meets the criteria for small, large, and non-pub counties to the left.
	Large Pub CNTY	≥ 500	≥ \$5 million	
	Non-Pub CNTY	≥ 1,000	≥ \$10 million	
Macro Data Change Viewer	Small Pub CNTY	≥ 300	≥ \$3 million	1) Change in macro cell levels that meets this criteria 2) Change that does not make macro cell levels fit historical data better after factoring in Summary of Difference (SOD) data from CCR Macro.
	Large Pub CNTY	≥ 500	≥ \$5 million	
	Non-Pub CNTY	≥ 1,000	≥ \$10 million	
Estimated Records File	Small State	≥ 500	≥ \$15 million	1) Records with IV* (Inclusion Version) = Current QVER 2) MEEI <i>not</i> = 2 3) Employment and total wages indicators = E
	Large State	≥ 1,000	≥ \$25 million	
Code Change Review File: Macro		≥ 1,000	≥ \$25 million	Large changes in the Summary of Difference for a macro cell.
Code Change Review File: Micro 3 (Non-CCS County Changes)		≥ 500	≥ \$10 million	Reporting units with data levels that meet this criteria
Pub County Research in Mic/Mac Analyzer ("Highlighted Counties only")	Small Pub CNTY	≥ 300	≥ \$3 million	1) For counties in the News Release (NR) rankings for employment change, focus on OTY change in M3 for supersectors and 6-digits contributing to the county's employment growth (e.g., if county growth rates is positive, focus on positive growth). See #3 for counties with growth rates ranging from -1.0% to 1.0%. 2) For counties in the NR rankings for AWW change, focus on AWW Impact contributing to the county's AWW growth (e.g., if county
	Large Pub CNTY	≥ 500	≥ \$5 million	

			<p>growth rate is positive, focus on negative AWW impacts). Research supersectors and industries with +/- 0.3 percentage point impacts. Also research other large TW or AME changes. See #3 for counties with growth rates ranging from -1.0% to 1.0%.</p> <p>3) If a county is ranked and has a growth rate ranging from -1.0% to 1.0% (inclusive, i.e., -1.0% <= county growth rate <= 1.0%), review both contributing and offsetting changes that meet criteria. The write-up tool will include up to 3 offsetting supersectors and industries for a county with a growth rate that falls within this range near zero.</p>
	<p>10 Largest CNTY</p>		<p>3) For 10 largest counties, complete review of all private supersectors and combined government. Cover increases and decreases in M3 employment, and positive and negative AWW impacts. Use the following as a guideline:</p> <p>3.1) M3 employment review</p> <p>3.1.1) Within all private supersectors and combined government, review all 6-digit level changes $\geq 1,000$. If there are less than three changes $\geq 1,000$, review smaller changes to reach a total of three reviewed industries for employment increase.</p> <p>3.1.2) Repeat this review for employment decreases. Within all private supersectors and combined government, review all 6-digit level changes $\leq -1,000$. If there are less than three changes $\leq -1,000$, review smaller changes to reach a total of three reviewed industries for employment decrease.</p> <p>3.2) AWW review</p> <p>3.2.1) Within all private supersectors and combined government, review all 6-digit industries with an AWW impact of +/- 0.2 percent.</p> <p>3.2.2) Review any industries with an absolute change of \$25 million in total wages where the change is an outlier based on analyst knowledge/experience.</p>

				<p><u>Note:</u> If a county is ranked and has a growth rate ranging from -1.0% to 1.0% (inclusive, i.e., -1.0% <= county growth rate <= 1.0%), the write-up tool will include up to 3 offsetting supersectors and industries.</p>
BEA Questions		≥ 300	≥ \$3 million	Only respond to BEA questions or forward the questions to the states if they involve changes of 300 or more workers or \$3 million or more in wages.

Footnotes:

Updated: March 27, 2017

- 1) Small Publication County: Annual average employment ≥ 75,000 but ≤ 100,000
 - 2) Large Publication County: Annual average employment ≥ 100,000
 - 3) Non-publication County: Annual average employment < 75,000 or County FIPS = 99X
 - 4) Large State: California, Florida, Georgia, Illinois, Michigan, New York, North Carolina, Ohio, Pennsylvania, Texas
- *Inclusion Version (IV) indicates the year/quarter when the record was first included on the state system.

LDB Review

The LDB micro group conducts a quarterly micro-level review. Using the EQUI files and the LDB, the staff examine micro level records with a) large unexplained over the quarter employment changes including openings, closings, expansions, and contractions; b) unclear predecessor / successor relationships; and c) predecessor / successor or MEEI double counting. Records questioned are identified through a program run by the national office based in part on edit flags 91, 96, 126, 139, 140, 160, 161, 178, and 179. These records may not appear on the national office-generated edit output available to the regional offices.

After signoff LDB analysts complete the large unmatched unit review. States are processed on a flow basis after a “preliminarily signoff” declaration from the Current Data Analysis (CDA) branch is received. DBES then runs the Continuous Unit (CU) processing methodology, which links about 99% of the records on the EQUI file. The remaining unlinked records are reviewed by analysts. Manual links are placed on the Forced Match File. The file is then provided to

DBES when the state review is complete. The LDB is loaded and state submitted back quarter corrections are applied. In first quarter, Annual Manual Corrections (AMCs), a supplemental set of corrections, are loaded to the LDB.

RO Review

Regional office review starts with the review of the QCEW/CES spreadsheets. One week prior to the EQUI official deliverable file due date each quarter the states submit QCEW macro data to their regional office. The regional offices take the QCEW macro data and CES data for the same time period and load it into the QCEW/CES spreadsheet for each state. Statewide graphs are created by three and six digit NAICS for each ownership type. The regions review the graphs in the spreadsheets in various ways. The regional offices send early macro questions based on their review to the states in time to be addressed before the official deliverable EQUI files are submitted to BLS one week later.

Regional office staff works with the national office and state staff to resolve NOQs. All NOQs go through the regional office before being sent to the states. The regional offices review the NOQs prior to sending them to the states. The regional offices also review the states' responses to the NOQs before returning them to the national office. They seek clarification from the national office or the states when necessary.

The regions develop ROQs based on their independent review of BLS edit listings. ROQs are shared with the national office, as are the states' responses. Regional office staff works with the states to ensure that I-errors and W-flags appearing on Table 9B (the Micro Edits Only Listing) are corrected or explained, based on edit priority. Regional staff also review publication edit failures and work with states to resolve these issues.

The regional offices work closely with the states in a variety of ways to monitor data quality in the states, both before the submission of the quarterly deliverable and during the cleanup period. Regional offices work with state-supplied macro data at several points in the quarterly processing cycle to generate and review the macro roll-up spreadsheets and to follow up where necessary. Regional offices receive and review the listings described in the previous sections, working with the states to identify problems and focus cleanup efforts. Regional offices also monitor state procedures to verify their effectiveness and efficiency.

13.3.2 State Correction Activity

State responses to BLS review questions are essential to the data quality of the QCEW program. Each state sends an EQUI to BLS that contains current quarter data as well as corrections to BLS-open quarters. (Some states may have open quarters that differ from BLS practice.) During the review period, each state responds to the NOQs and ROQs. The state responds with explanations and/or corrections. States are required to address all data issues on the NOQ form including micro records involving EDI reporters. The EDI Center should provide answers to the states for questions on EDI-provided data and should also provide answers to the email group

QCEWNOQ on all questions. The state should provide additional feedback on responses provided by EDI when necessary. Corrections resulting from NOQs and ROQs are either made through the BLS Corrections system or sent via a subset file. Late or minor corrections are usually held for transmission with next quarter's EQUI.

States should submit responses to NOQs within five working days after the questions are received by the regional office. States should submit responses to subset questions as soon as possible after the questions are sent out. States should work with their RO to provide timely and complete responses to the NOQs using the standardized form. The regions should send responses to NOQs to QCEWNOQ and EDIBLSStaff.

If requested by the national office, states should submit a subset file containing the largest corrections within seven working days of the EQUI due date. This file is rarely requested, but is sometimes needed to provide BEA and CES with data corrected for very large errors.

All priority A or B warning (W) flags printed on the BLS listings should be reviewed and the necessary corrections made. For W-flags, a correction consists of either a change to the data that removes the flag or (where the data are verified as accurate) an update with an appropriate comment code. If the data are unusual or large, or if the data change substantially, a narrative comment is very helpful for reviewers and data users and should be included.

13.3.3 Edit Priorities

BLS has established three levels of edit priority for data review and cleanup:

Priority A (first priority)

This group of edit flags primarily affects aggregated economic data. They affect key current QCEW data products for customers, and in particular, users such as the Current Employment Statistics (CES), BEA, and others listed in Section 13.4.1 who need the data soon after the deliverable is due. This group of edit flags also includes errors that affect the ability of the system to provide a company name and at least one usable address to BLS survey users.

The priority A edits include all the macro edits:

Level 5 – Significant Employment and Wage Macro Edits

091-W Employment Change Greatly Exceeds Test Parameters

092-W AQW Change is significantly > Parameter and Exceeds Twice the Quartile AQW Range

093-W Average Employment is significantly > Parameter, but Total Wages = 0

094-W Average Employment = 0, but Total Wages is significantly > Parameter

Level 6 – Warning Macro Edits

126-W Employment Change Exceeds Test Parameters

127-W AQW Change > Parameter and Exceeds Twice the Quartile AQW Range

130-W Average Employment > Parameter, but Total Wages = 0

- 131-W Average Employment = 0, but Total Wages > Parameter
- 134-W Number of Establishments out of Range
- 135-W New or Discontinued Macro Record

Priority A also includes the following micro edits:

Level 1 – Pre-edits

- 002-I Invalid UI Account Number
- 003-I Invalid Reporting Unit Number
- 004-I Invalid Reference Year
- 005-I Invalid Reference Quarter
- 006-I Invalid State Code

Level 2 – Key Field edits

- 010-I Invalid NAICS Code
- 012-I Invalid Ownership Code
- 013-I Invalid County Code
- 016-I NAICS & Ownership Inconsistent

Level 3 – Date and Status Code Edits

- 025-I Invalid Status Code

Level 4 – Remaining Invalid Error Edits

- 031-I Invalid First Month Employment
- 032-I Invalid Second Month Employment
- 033-I Invalid Third Month Employment
- 034-I Invalid Total Wages
- 035-I Invalid Taxable Wages
- 036-I Invalid Contributions
- 039-I Invalid Type of Coverage
- 040-I Invalid MEEI Code
- 045-I Invalid Federal EI Number
- 056-I Inconsistent Ownership/Type of Coverage
- 057-I Taxable Wages on Federal Record
- 058-I Contributions on Federal Record
- 059-I Taxable Wages > 0 for Non-experience-rated Record
- 060-I Contributions > 0 for Non-experience-rated Record
- 062-I Taxable Wages > Total Wages
- 063-I Contributions > Taxable Wages
- 064-I MEEI/RUN Inconsistent
- 065-I Inconsistent County/Township Combination
- 070-I No Usable Address
- 072-I Both Trade Name and Legal Name are Blank
- 080-I Indian Tribal Indicator Inconsistent with NAICS or OWN

Level 5 – Significant Employment and Wage Micro Edits

- 085-W Potential Predecessor (UI #) found based on Wage Records
- 086-W Potential Successor (UI #) found based on Wage Records
- 089-W **WIN-202 Only:** Month 1 Employment Change Greatly Exceeds Test Parameters
- 090-W **WIN-202 Only:** Month 2 Employment Change Greatly Exceeds Test Parameters
- 091-W **EXPO and BLS:** Employment Change Greatly Exceeds Test Parameters
WIN-202: Month 3 Employment Change Greatly Exceeds Test Parameters
- 092-W AQW Change is significantly > Parameter and Exceeds Twice the Quartile AQW Range
- 093-W Average Employment is significantly > Parameter, but Total Wages = 0
- 094-W Average Employment = 0, but Total Wages is significantly > Parameter
- 095-W Total Wages = Sum of Employment +/- Parameter if AME is Large
- 096-W Unusually Large New Record on File
- 097-W Unusually Large Discontinued Record Inactivated
- 099-W Questionable Large Imputation

Level 6 – Warning Micro Edits

- 116-W EIN missing for More Than Parameter Months
- 126-W **EXPO and BLS Only:** Employment Change Exceeds Test Parameters (edits 136, 137, and 138 in WIN-202)
- 127-W AQW Change > Parameter and Exceeds Twice the Quartile AQW Range
- 130-W Average Employment > Parameter, but Total Wages = 0
- 131-W Average Employment = 0, but Total Wages > Parameter
- 132-W Total Wages = Sum of Employment +/- Parameter
- 133-W Unclassified Industry Employment > Parameter
- 136-W **WIN-202 Only:** Month 1 Employment Change Exceeds Test (edit 126 in EXPO and BLS)
- 137-W **WIN-202 Only:** Month 2 Employment Change Exceeds Test (edit 126 in EXPO and BLS)
- 138-W **WIN-202 Only:** Month 3 Employment Change Exceeds Test (edit 126 in EXPO and BLS)
- 139-W New Record?
- 140-W Discontinued Record?

Level 8 – Multi-establishment Edits

- 171-W First Month Employment Not in Balance
- 172-W Second Month Employment Not in Balance
- 173-W Third Month Employment Not in Balance
- 174-W Total Wages Not in Balance
- 175-W Taxable Wages Not in Balance
- 176-W Contributions Not in Balance
- 178-I Master Without Multiple Worksites
- 179-I Worksite Missing Master
- 180-I Single Account/Active Worksites
- 181-I Worksite Ownership Code Differs from Master

- 182-I Worksite EIN Differs from Master
- 185-I Inconsistent Indian Tribal Codes within the Multi Account

Priority B (second priority)

This group includes micro edit flags with smaller economic impact as well as flags for ARS data, and longitudinal (predecessor/successor) information:

Level 4 – Remaining Invalid Error Edits

- 043-I Invalid Predecessor SESA ID
- 044-I Invalid Successor SESA ID
- 046-I Invalid ARS Response Code/Year
- 066-I Invalid Format in Predecessor Account
- 067-I Invalid Format in Successor Account
- 074-I Invalid Old Ownership
- 075-I Invalid Old County
- 076-I Invalid Old County/Old Township Combination
- 078-I Invalid Old NAICS Code

Level 6 – Warning Edits

- 088-W Large Record without Usable PLA
- 120-W Possible Non-Economic Code Change
- 121-W Code Change Back to a Recent Code
- 123-W Expected Code Change Not Made
- 146-W Old Codes Are Inconsistent with 4th Quarter Codes

Level 7 – Predecessor/Successor Edits

- 156-W Predecessor/Successor County Code Change Conflict
- 157-W Predecessor/Successor Ownership Change Conflict
- 159-W Predecessor/Successor Township Code Change Conflict
- 160-W Both Predecessor and Successor Reported
- 161-W Neither Predecessor nor Successor Reported
- 164-W Predecessor/Successor NAICS Code Change Conflict

Priority C (third priority)

The remaining edit flags are concerned with miscellaneous address and administrative information. After the first two priorities are addressed, states should attend to the remainder of the edit flags.

Level 1 – Pre-edits

- 001-I Invalid Transaction Code

Level 3 – Date and Status Code Edits

- 021-I Invalid Initial Liability Date Format
- 022-I Invalid EOL Date Format
- 023-I Invalid Setup Date Format

024-I Reactivation Date Invalid or Earlier than Liability Date

Level 4 – Remaining Invalid Error Edits

047-I Invalid Tax Rate - Beyond Minimum/Maximum Range
048-I Invalid Comment Code
049-I Invalid First Month Employment Indicator
050-I Invalid Second Month Employment Indicator
051-I Invalid Third Month Employment Indicator
052-I Invalid Total Wages Indicator
053-I Invalid Taxable Wages Indicator
054-I Invalid Contributions Due Indicator

Level 6 – Warning Edits

101-W Unusable Address Type Code
102-W Blank Physical Location City; Other PLA Fields Present
103-W Unusable Physical Location State Abbreviation
104-W Unusable Physical Location Zip Code Format
105-W Unusable Telephone Format
106-W Blank UI City; Other UI Address Fields Present
107-W Unusable UI State Abbreviation
108-W Unusable UI Zip Code Format
109-W Blank Mailing/Other City, Other M/O Address Fields Present
110-W Unusable Mailing/Other State Abbreviation
111-W Unusable Mailing/Other Zip Code Format
112-W Questionable Fax Number Format
114-W P.O. Box, Blank Street. Or Out-of-State in PLA Block
118-W Computed Tax Rate > TOL % from Reported, and Computed Tax TOL from
 Reported
119-W First QTR Taxable Wages Missing for Experience-Rated Account
124-W Inactive Record with Reported Employment/Wage Data
125-W Data Reported Prior to Liability Date
128-W Identical Monthly Employment > Parameter
129-W Taxable/Total Wage Ratio > Prior Year Ratio by Parameter %

Level 9 – Warning Edits

191-W Questionable Wage Record Count
192-W Questionable Wage Record Wages
193-W First Month Employment > Wage Record Count
194-W Second Month Employment > Wage Record Count
195-W Third Month Employment > Wage Record Count
196-W All Months Employment = Wage Record Count
197-W Total Wages Vary from Wage Records
198-W Divergent Employment Trends

13.3.4 Subset File

The EQUI deliverable files are due once a quarter on the dates given in Appendix D. The subset deadline falls approximately four weeks after the EQUI files are due; these dates also appear in Appendix D. Increasingly, subsets are becoming unnecessary for BLS review and correction. In some cases, significant issues can be corrected only via subsets. However, BLS now has the capacity to make almost all changes in the version of the file located at BLS. Changes made in the state after the deliverable are automatically included in the next primary file.

If generated, the subset file should include corrections resulting from the national office and regional office questions, if a subset is required by either group. It should not be generated before the state has processed the NOQs and ROQs. If a subset is not required by the national office or the regional office, the state can still send one. The state can choose the records to be included on the subset. State data submittals, other than the EQUI or the scheduled subset file, must be approved by CDA before they are generated. This includes any files the State may want to submit after the four-week deadline has passed.

If the state (or BLS review staff) wishes to submit a subset file, that file must be transmitted to BLS in time to meet the subset deadline. Regional offices should work with their states to ensure that the data are edited and reviewed prior to submission of the subset to BLS. State processing schedules may need to be adjusted to allow for this editing and review. States and regional offices also need to allow time for the corrections to be received and processed by BLS. Except in extraordinary cases, subsets which miss the deadline will be held for processing with the next quarterly deliverable.

The edit output tables from the subset file processing are produced in the national office immediately after the subset file due date. Subsets accepted by CDA earlier than the due date are processed immediately upon acceptance. The national office then has one working day to get questions out to the regional offices. The regional offices are to confer with the states on getting responses back to the national office as soon as possible. This allows the regional offices to certify the files clean by the deadline. If errors are found during the review of the state's correction file, the regional offices and the national office consult to determine the best course of action. Usually, corrections are held for submission with the next quarter's EQUI deliverable. If the error is large, a BLS correction will be made to close out the BLS review and correction process.

13.3.5 Clean Declaration/Quarterly Signoff

For a State's QCEW data to be considered clean, the state must do the following:

- Correct all invalid errors listed in the Priority A and Priority B groups and printed in Table 9B.
- Answer all NOQs and correct the data if needed.

- Resolve all ROQs and correct the data if needed.

In addition, all invalid errors should be corrected, and all warnings in those groups that are printed on the national office listings should be reviewed and the necessary corrections made in the states' systems. Corrections not specifically requested by the national office may be held for the next quarterly deliverable rather than sent in a subset.

If no further corrections to a file are necessary, the state notifies the regional office that the data file is clean. The regional and national offices use a tracking tool called the Signoff and Subset Log to track whether a subset is required from a state and to track preliminary and final quarterly signoff. Once the appropriate entries are made in the signoff log, the tool generates emails to the national and regional office. Emails are generated with three signoff log entries; one for regional office signoff, one for CDA preliminary signoff and one for CDA final signoff. Regional offices forward CDA final signoff notification to the states. If a State's data do not meet the standard clean definition, even after updates, the national office will consult with the regional office to determine the best course of action. Clean designation does not influence BLS publication processing, which is driven by the resolution of CDA and LDB review questions.

13.4 BLS Estimates for Late Files

If a state is unable to submit a quarterly deliverable, the national office will create a replacement file for use in creating national totals. The replacement file will consist of a copy of the last quarterly deliverable received from the state. All data for the late state will be suppressed by BLS. This happened once during the first 20 years of mic/mac processing.

When production is resumed, the replacement will be removed and real data will be added back to the BLS system as time and resources permit.

EXHIBIT 13A

DATE: MM/DD/YYYY		TIME: 07:07:00 AM		(STATE NAME)			PAGE 1	
INITIAL RUN	YYYY/Q	COMPARISON OF EQUI TOTALS TO DATA REPORTED ON THE TRAILER RECORD - TABLE 1A			** CONFIDENTIAL DATA **			
BUREAU OF LABOR STATISTICS - EQUI PROCESSING								
YEAR/QTR.	TOTAL RECORDS ON TRAILER.	TOTAL RECORDS ON EQUI.		NET DIFFERENCE.				
2005/1	8,904	8,904		0				
2004/4	2,350	2,350		0				
2004/3	1,253	1,253		0				
N/A	0	0		0				
N/A	0	0		0				
TRAILER DELETED RECORDS.		EQUI DELETED RECORDS.		NET DIFFERENCE.				
43		43		0				
ALL QUARTERS ON TRAILER RECORD:								
ALL RECORDS	NO. ESTABL.	MONTH 1 EMPL.	MONTH 2 EMPL.	MONTH 3 EMPL.	TOTAL WAGES.	TAXABLE WAGES.	CONTRIBUTIONS.	
TRAILER	12,507	202,119	201,888	204,566	1,781,531,266	640,537,198	11,572,977	
EQUI	12,507	202,119	201,888	204,566	1,781,531,266	640,537,198	11,572,977	
DIFF.	0	0	0	0	0	0	0	
CURRENT QUARTER COUNTS-2005/1								
TOTAL	NO. ESTABL.	MONTH 1 EMPL.	MONTH 2 EMPL.	MONTH 3 EMPL.	TOTAL WAGES.	TAXABLE WAGES.	CONTRIBUTIONS.	
TRAILER	8,904	178,816	178,237	180,477	1,617,456,564	518,127,311	9,270,354	
EQUI	8,904	178,816	178,237	180,477	1,617,456,564	518,127,311	9,270,354	
DIFF.	0	0	0	0	0	0	0	
FEDERAL OWN.	NO. ESTABL.	MONTH 1 EMPL.	MONTH 2 EMPL.	MONTH 3 EMPL.	TOTAL WAGES.	TAXABLE WAGES.	CONTRIBUTIONS.	
TRAILER	2,350	15,865	16,145	16,601	99,853,224	72,023,894	1,369,444	
EQUI	3	731	732	731	10,407,582	0	0	
DIFF.	2,347	15,134	15,413	15,870	89,445,642	72,023,894	1,369,444	
STATE OWN.	NO. ESTABL.	MONTH 1 EMPL.	MONTH 2 EMPL.	MONTH 3 EMPL.	TOTAL WAGES.	TAXABLE WAGES.	CONTRIBUTIONS.	
TRAILER	1,253	7,438	7,506	7,488	64,221,478	50,385,993	933,179	
EQUI	47	12,726	12,561	13,156	119,401,159	0	0	
DIFF.	1,206	-5,288	-5,055	-5,668	-55,179,681	50,385,993	933,179	
LOCAL OWN.	NO. ESTABL.	MONTH 1 EMPL.	MONTH 2 EMPL.	MONTH 3 EMPL.	TOTAL WAGES.	TAXABLE WAGES.	CONTRIBUTIONS.	
TRAILER	0	0	0	0	0	0	0	
EQUI	49	31,514	30,734	33,325	283,331,485	4,300,635	68,180	
DIFF.	-49	-31,514	-30,734	-33,325	-283,331,485	-4,300,635	-68,180	
PRIVATE OWN.	NO. ESTABL.	MONTH 1 EMPL.	MONTH 2 EMPL.	MONTH 3 EMPL.	TOTAL WAGES.	TAXABLE WAGES.	CONTRIBUTIONS.	
TRAILER	0	0	0	0	0	0	0	
EQUI	8,805	133,845	134,210	133,265	1,204,316,338	513,826,676	9,202,174	
DIFF.	-8,805	-133,845	-134,210	-133,265	-1,204,316,338	-513,826,676	-9,202,174	
END OF THE COMPARISON OF EQUI TOTALS TO DATA REPORTED LISTING.								

EXHIBIT 13B

DATE: MM/DD/YYYY	TIME: 06:21:06 AM	(STATE)	PAGE 1		
INITIAL RUN	YYYY/Q	PRE-EDIT ERROR SUMMARY COUNTS - TABLE 1B			
		BUREAU OF LABOR STATISTICS - EQUI PROCESSING			
RECORDS READ	:	181,834			
RECORDS WITH NO PRE-EDIT ERRORS	:	181,447			
RECORDS WITH NO PRE-EDIT ERRORS (EDIT CODES 001-006)	:	181,834			
RECORDS WITH ONE OR MORE EDIT FIELDS WITH EDIT FLAGS (EDIT CODES 001-006)	:	0			
FIELDS FLAGGED (EDIT CODES 001-006)	:	0			
RECORDS SUBMITTED FOR LOCKED YEAR/QUARTERS	:	0			
EDIT FLAGS	:	0			

DESCRIPTION	EDIT CODE	2005/1	2004/4	ALL OTHER QUARTERS
INVALID TRANSACTION CODE	001	0	0	0
INVALID UI ACCOUNT NUMBER	002	0	0	0
INVALID REPORTING UNIT NUMBER	003	0	0	0
INVALID REFERENCE YEAR	004			0
INVALID REFERENCE QUARTER	005			0
INVALID STATE CODE	006	0	0	0
TOTAL		0	0	0

EXHIBIT 13C

DATE: MM/DD/YYYY		TIME: 07:07:00 AM		(STATE NAME)										PAGE		
INITIAL RUN		YYYY/Q		PRE-EDIT LISTING - TABLE 1C										CONFIDENTIAL DATA		
BUREAU OF LABOR STATISTICS - EQUI PROCESSING													1			
TRAN													EMPLOYMENT			
CD	ST	YEAR/Q	UI ACCT NO	RUN	STAT	NAME	EI NUMBER	EDI	NAICS	OWN	CTY	CD	M1	M2	M3	
A	66	2005/1	0000065432	00000	1	LACKLUSTER VIDEOS INC	000000000				532230	5	000	1		
SETUP DATE: 1989/11/28 INITIAL LIAB DATE: 1989/11/28 END OF LIAB DATE:													/	/	/	
13-I INVALID COUNTY CODE																
A	66	2005/1	0000065434	00000	1	NEEDLESS MARKUP DEPARTMEN	029876543			000000	0	000	1			
SETUP DATE: / / INITIAL LIAB DATE: 1999/10/01 END OF LIAB DATE:													1998/12/31		/	/
12-I INVALID OWNERSHIP CODE																
13-I INVALID COUNTY CODE																
A	66	2005/1	0000065436	00000	1	CUTTLEVISION MFR, INC	119876543			515210	5	000	1	000068	000060	
000067																
SETUP DATE: 1998/01/01 INITIAL LIAB DATE: 1999/10/01 END OF LIAB DATE:													/	/	/	
13-I INVALID COUNTY CODE																
A	66	2005/1	0000065440	00000	1	A D D CO SUSHI-CO RESTAUR	29876543			999999	5	000	1			
SETUP DATE: 1982/10/01 INITIAL LIAB DATE: 1982/10/01 END OF LIAB DATE:													/	/	/	
13-I INVALID COUNTY CODE																
A	66	2005/1	0000065444	00000	1	BUB FOLDING BOOKS CO INC	049876543			000000	0	000	1	000001		
SETUP DATE: / / INITIAL LIAB DATE: 2000/10/01 END OF LIAB DATE:													/	/	/	
12-I INVALID OWNERSHIP CODE																
13-I INVALID COUNTY CODE																
A	66	2005/1	0000065450	00000	1		229876789			000000	0	000	1	000005	000005	
000005																
SETUP DATE: / / INITIAL LIAB DATE: 2000/10/01 END OF LIAB DATE:													1997/12/31		/	/
12-I INVALID OWNERSHIP CODE																
13-I INVALID COUNTY CODE																
*** END OF PREEDIT ***																

EXHIBIT 13D

DATE: MM/DD/YYYY		TIME: 06:07:08 PM		(STATE)										PAGE 1	
INITIAL RUN YYYY/Q		STATE TOTALS - TABLE 2A										** CONFIDENTIAL DATA **			
BUREAU OF LABOR STATISTICS - EQUI PROCESSING															
STATE TOTAL															
YEAR/Q	AME (000S)	OTQ PCT	OTY PCT	AWW	OTQ PCT	OTY PCT	NUM EST (000S)	M1 (000S)	M2 (000S)	M3 (000S)	TOT W (IN B)	TAX W (IN B)	CONT (IN M)		
2003/2	1,782	2	0	577	-1	2	123.37	1,774	1,785	1,786	13.37	2.22	44.9		
2003/3	1,764	-1	0	580	0	2	106.86	1,747	1,772	1,774	13.30	1.33	27.6		
2003/4	1,773	0	0	624	8	3	106.41	1,772	1,771	1,775	14.38	1.12	23.9		
2004/1	1,753	-1	0	596	-4	2	109.65	1,738	1,748	1,774	13.58	6.86	149.5		
2004/2	1,803	3	1	595	0	3	111.54	1,793	1,805	1,811	13.94	2.31	52.4		
2004/3	1,793	-1	2	603	1	4	113.05	1,775	1,800	1,803	14.05	1.43	33.1		
2004/4	1,809	1	2	655	9	5	114.52	1,806	1,809	1,811	15.41	1.20	28.3		
2005/1	1,788	-1	2	611	-7	3	116.07	1,774	1,788	1,800	14.20	7.03	153.5		
PRIVATE SECTOR															
YEAR/Q	AME (000S)	OTQ PCT	OTY PCT	AWW	OTQ PCT	OTY PCT	NUM EST (000S)	M1 (000S)	M2 (000S)	M3 (000S)	TOT W (IN B)	TAX W (IN B)	CONT (IN M)		
2003/2	1,466	2	0	564	-2	2	120.12	1,455	1,467	1,476	10.75	2.20	44.7		
2003/3	1,465	0	0	566	0	2	103.68	1,468	1,469	1,459	10.79	1.33	27.5		
2003/4	1,455	-1	0	621	10	4	103.23	1,456	1,453	1,455	11.75	1.12	23.8		
2004/1	1,437	-1	0	586	-6	2	106.43	1,424	1,432	1,456	10.94	6.81	148.6		
2004/2	1,487	3	1	582	-1	3	108.27	1,476	1,487	1,500	11.26	2.29	52.1		
2004/3	1,493	0	2	588	1	4	109.78	1,498	1,495	1,487	11.42	1.42	33.0		
2004/4	1,489	0	2	651	11	5	111.24	1,487	1,489	1,490	12.61	1.20	28.2		
2005/1	1,467	-1	2	604	-7	3	112.79	1,457	1,467	1,478	11.52	6.98	152.7		
FEDERAL GOVERNMENT															
YEAR/Q	AME (000S)	OTQ PCT	OTY PCT	AWW	OTQ PCT	OTY PCT	NUM EST (000S)	M1 (000S)	M2 (000S)	M3 (000S)	TOT W (IN B)	TAX W (IN B)	CONT (IN M)		
2003/2	28	-1	0	898	-4	2	0.61	28	28	28	0.33				
2003/3	28	0	0	955	6	4	0.60	28	28	28	0.35				
2003/4	28	0	-2	921	-4	2	0.60	28	28	28	0.34				
2004/1	28	-1	-2	994	8	7	0.64	28	28	28	0.36				
2004/2	28	1	0	938	-6	4	0.64	28	28	28	0.34				
2004/3	28	1	1	1,019	9	7	0.65	29	28	28	0.38				
2004/4	28	-1	0	982	-4	7	0.65	28	28	28	0.36				
2005/1	28	1	2	993	1	0	0.65	28	28	28	0.37				
STATE GOVERNMENT															
YEAR/Q	AME (000S)	OTQ PCT	OTY PCT	AWW	OTQ PCT	OTY PCT	NUM EST (000S)	M1 (000S)	M2 (000S)	M3 (000S)	TOT W (IN B)	TAX W (IN B)	CONT (IN M)		
2003/2	88	-1	-1	654	2	2	0.80	90	89	86	0.75	0.00	0.0		
2003/3	85	-3	-2	661	1	2	0.80	84	84	88	0.73	0.00	0.0		
2003/4	89	4	-2	649	-2	1	0.80	88	89	89	0.75	0.00	0.0		
2004/1	88	-1	-2	659	2	2	0.80	86	88	88	0.75	0.00	0.1		
2004/2	88	0	0	638	-3	-2	0.85	89	88	86	0.73	0.00	0.1		
2004/3	86	-2	1	679	7	3	0.84	85	85	88	0.76	0.00	0.0		
2004/4	89	4	1	676	-1	4	0.85	89	89	89	0.78	0.00	0.0		
2005/1	88	-1	1	676	0	3	0.85	86	89	89	0.77	0.00	0.1		

EXHIBIT 13E

DATE: MM/DD/YYYY		TIME: 06:06:06 PM		(STATE)				PAGE 1							
INITIAL RUN		YYYY/Q		COUNTY SUMMARY- TABLE 2B SUMMARY PAGE				** CONFIDENTIAL DATA **							
BUREAU OF LABOR STATISTICS - EQUI PROCESSING															
		--M3 EMPLOYMENT--				-----AWW-----									
		T	ADJ	T	ADJ	T	ADJ	T	ADJ	T	ADJ				
		OTY	OTY	OTY	OTY	OTY	OTY	OTY	OTY	OTY	OTY				
		%CHG	%CHG	%CHG	%CHG	%CHG	%CHG	%CHG	%CHG	%CHG	%CHG				
(STATE)	TOTAL	+1.5	+1.5		+2.5	+2.5									
001	ABBEY	+2.9	+3.2		-0.6	-1.0		057	HURRY	+4.6	+2.8		+0.4	-1.2	
003	ACH	-0.2	-0.3		-0.8	-0.8		059	JASH	+10.1	+12.3		+3.6	+3.4	
005	ALLENTOWN	-5.0	-5.2		+7.5	+7.5		061	KEYSHONE	+1.6	-0.7		+5.9	+4.4	
007	ANDYTAYLOR	+0.0	+0.2		+1.3	+1.3		063	LANCASTER	-1.4	-0.6		+9.8	+10.0	
009	BAMBI	+0.5	+0.7		+1.6	+1.6		065	LAURAYS	+4.0	+5.4		+4.9	+4.5	
011	BARNSNOBLE	-0.4	-0.3		+0.4	+0.2		067	LIE	-2.0	-2.1		+2.9	+2.9	
013	BUFORD	+2.8	+3.1		+2.2	+2.1		069	LEX_LUTHER	+5.3	+2.7		+4.8	+3.8	
015	BRINKLY	+0.3	+3.8		+0.6	+0.9		071	MCCORMICK	+0.9	+0.3		+0.6	+0.6	
017	CALLOWAY	+0.5	+5.0		-4.6	-4.1		073	MARTIAL	-4.9	-6.2		+2.6	+2.4	
019	CHARLES	+2.7	+2.5		+3.3	+3.5		075	MARLBORO	+0.3	+0.2		+2.4	+2.4	
025	CHERRY	-5.1	-5.2		+1.0	+1.0		077	NEWSBORO	+3.5	+3.0		+2.9	+3.1	
027	CHESS_MASTER	+4.5	+5.0		+4.0	+4.0		079	OCOCHOBEE	-1.4	-1.0		-0.2	-0.3	
029	CHESTERFIELD	-0.4	-1.2		+0.6	+1.2		083	ORANGE	-0.1	+0.3		+1.9	+1.5	
031	CLAIRE	+0.2	+0.0		+0.9	+0.7		085	PIGSKIN	+0.9	+1.1		-0.4	-0.2	
035	COLLECTION	-1.4	-1.5		+2.1	+1.8		087	RICHERTHAN	+3.0	+0.5		+2.2	+1.6	
037	DARLING	-0.1	-0.4		+7.5	+7.3		089	SALADA	-1.1	+2.0		+4.8	+3.6	
039	DILLSOWER	+0.4	+6.0		-1.4	+1.6		091	SPRINGMOUNT	+0.7	+0.2		+3.2	+3.3	
041	DORCA	+2.9	+2.2		+1.1	+0.6		093	SUMMER	+0.9	+0.9		-0.8	-0.8	
043	EDGEFIELD	-3.2	-3.5		+1.0	+1.0		095	UNICORN	+0.0	-1.0		+4.2	+3.9	
045	FAIRFAZ	+3.9	+3.8		-3.1	-2.8		097	WILLIAMS	+1.2	+3.6		+6.2	+5.8	
047	FLOE	-2.1	-7.4		+1.4	-1.0		101	YORKSHIRE	+1.5	+1.5		+3.5	+3.3	
049	GEORGET	+7.0	+8.5		+7.7	+7.3		995	STATEWIDE, LOCS IN MORE THAN	+5.3	+319.8		-7.7	-25.5	
051	GREENWHICH	+1.5	+1.2		+0.6	+0.6		996	FOREIGN LOCATIONS	-22.7	-22.7		+48.8	+48.8	
053	GREENWOOD	+0.5	-0.5		-1.2	-0.9		998	OUT OF STATE	-33.3	-33.3		+226.5	+226.5	
055	HAMPTON	+0.3	+0.8		+3.5	+4.0		999	UNKNOWN LOCATIONS	-6.0	-7.4		+22.5	+22.2	

END OF THE COUNTY SUMMARY 2B LISTING

EXHIBIT 13E (continued)

DATE: MM/DD/YYYY		TIME: 06:06:06 PM		(STATE)				PAGE 1									
INITIAL RUN YYYY/Q		COUNTY SUMMARY - TABLE 2B								** CONFIDENTIAL DATA **							
BUREAU OF LABOR STATISTICS - EQUI PROCESSING																	
COUNTY: 001 ABBEY										ANNUAL 2004: AE		6,739		%CHG		+1.8	
										AAW \$		27,138		%CHG		+3.6	
-----M3 EMPLOYMENT-----																	
OWN	2004/1	2005/1	%CHG	OTY LEVEL	CHANGE	2004/1	2005/1	%CHG	OTY LEVEL	CHANGE	2004/1	2005/1	%CHG	OTY LEVEL	CHANGE		
1	43	42	-2.3	-1	813	791	-2.7	-16,117	45	44	-2.2	-1					
2	231	232	+0.4	+1	556	559	+0.5	+16,625	232	233	+0.4	+1					
3	1,225	1,237	+1.0	+12	515	521	+1.2	+218,594	1,208	1,226	+1.5	+18					
5	5,238	5,440	+3.9	+202	496	488	-1.6	+670,017	5,178	5,368	+3.7	+190					
T	6,737	6,951	+3.2	+214	504	499	-1.0	+889,119	6,663	6,872	+3.1	+209					
T ADJ	6,758	6,951	+2.9	+193	502	499	-0.6	+874,397	TW LEVEL 2005/1		44,533,392						
QAF	+21			TW 2004/1		+14,722											
COUNTY: 003 ACH										ANNUAL 2004: AE		57,013		%CHG		+1.1	
										AAW \$		38,458		%CHG		+1.2	
-----M3 EMPLOYMENT-----																	
OWN	2004/1	2005/1	%CHG	OTY LEVEL	CHANGE	2004/1	2005/1	%CHG	OTY LEVEL	CHANGE	2004/1	2005/1	%CHG	OTY LEVEL	CHANGE		
1	820	770	-6.1	-50	1,060	1,041	-1.8	-952,589	825	769	-6.8	-56					
2	1,676	1,681	+0.3	+5	594	627	+5.6	+603,606	1,662	1,648	-0.8	-14					
3	4,927	5,468	+11.0	+541	634	592	-6.6	+847,858	4,876	5,335	+9.4	+459					
5	49,083	48,400	-1.4	-683	750	748	-0.3	-7,380,951	48,908	48,225	-1.4	-683					
T	56,506	56,319	-0.3	-187	740	734	-0.8	-6,882,076	56,271	55,977	-0.5	-294					
T ADJ	56,441	56,319	-0.2	-122	740	734	-0.8	-6,516,199	TW LEVEL 2005/1		534,109,841						
QAF	-65			TW 2004/1		-365,877											
COUNTY: 005 ALLENTOWN										ANNUAL 2004: AE		3,337		%CHG		-4.4	
										AAW \$		30,219		%CHG		+6.8	
-----M3 EMPLOYMENT-----																	
OWN	2004/1	2005/1	%CHG	OTY LEVEL	CHANGE	2004/1	2005/1	%CHG	OTY LEVEL	CHANGE	2004/1	2005/1	%CHG	OTY LEVEL	CHANGE		
1	29	27	-6.9	-2	583	624	+7.0	+7,424	29	28	-3.4	-1					
2	447	444	-0.7	-3	568	594	+4.6	+102,101	447	441	-1.3	-6					
3	916	859	-6.2	-57	457	439	-3.9	-540,703	872	813	-6.8	-59					
5	2,050	1,933	-5.7	-117	582	649	+11.5	+1,235,987	2,035	1,971	-3.1	-64					
T	3,442	3,263	-5.2	-179	548	589	+7.5	+804,809	3,382	3,252	-3.8	-130					
T ADJ	3,433	3,263	-5.0	-170	548	589	+7.5	+851,824	TW LEVEL 2005/1		24,899,491						
QAF	-9			TW 2004/1		-47,015											

EXHIBIT 13E (continued)

DATE: MM/DD/YYYY		TIME: 06:06:06 PM		(STATE)		PAGE 28						
INITIAL RUN YYYY/Q		COUNTY SUMMARY - TABLE 2B						** CONFIDENTIAL DATA **				
BUREAU OF LABOR STATISTICS - EQUI PROCESSING												

COUNTY: 999 UNKNOWN LOCATIONS												
-----M3 EMPLOYMENT----- -----AWW----- -----TW----- -----AME-----												
OWN	2004/2	2005/2	OTY %CHG	OTY LEVEL CHANGE	2004/2	2005/2	OTY %CHG	OTY LEVEL CHANGE	2004/2	2005/2	OTY %CHG	OTY LEVEL CHANGE
1	0	0	+0.0	+0	0	0	+0.0	+0	0	0	+0.0	+0
2	0	0	+0.0	+0	0	0	+0.0	+0	0	0	+0.0	+0
3	0	0	+0.0	+0	0	0	+0.0	+0	0	0	+0.0	+0
5	127	106	-16.5	-21	671	738	+10.0	-31,844	117	103	-12.0	-14
T	127	106	-16.5	-21	671	738	+10.0	-31,844	117	103	-12.0	-14
T ADJ	127	106	-16.5	-21	671	738	+10.0	-31,844	TW LEVEL 2005/2		985,388	

STATE TOTAL												
-----M3 EMPLOYMENT----- -----AWW----- -----TW----- -----AME-----												
OWN	2004/2	2005/2	OTY %CHG	OTY LEVEL CHANGE	2004/2	2005/2	OTY %CHG	OTY LEVEL CHANGE	2004/2	2005/2	OTY %CHG	OTY LEVEL CHANGE
1	46,492	45,911	-1.2	-581	1,002	1,013	+1.1	+795,687	46,310	45,896	-0.9	-414
2	74,898	77,585	+3.6	+2,687	573	595	+3.8	+40,274,904	80,133	82,359	+2.8	+2,226
3	169,130	179,053	+5.9	+9,923	582	585	+0.5	+85,075,376	173,172	183,439	+5.9	+10,267
5	1,136,851	1,162,469	+2.3	+25,618	560	580	+3.6	+483,128,457	1,131,967	1,157,095	+2.2	+25,128
T	1,427,380	1,465,018	+2.6	+37,638	578	595	+2.9	+609,219,192	1,431,591	1,468,789	+2.6	+37,198
T ADJ	1,427,284	1,464,966	+2.6	+37,682	578	595	+2.9	+609,318,687	TW LEVEL 2005/2		11,359,290,829	
EXCLUD	-96	-52			TW 2004/2		-546,374	TW 2005/2		-446,879		

EXHIBIT 13F

	CURRENT QTR TOT	% OF CURR TOTAL RECS	PREV.QTR TOTAL	% CHG
TOTAL NUMBER OF ACTIVE, COVERED RECORDS EXCLUDE DELETES	117,401	100.00	115,734	1.44
TOTAL NUMBER OF INACTIVE, PENDING, OR NON-COVERED RECORDS	4,500		3,562	
TOTAL NUMBER OF ACTIVE, COVERED RECORDS EXCLUDING MASTERS MONTH 3 EMPLOYMENT	116,069	98.86	114,404	1.45
# ACTIVE COVERED RECORDS WITH REPORTING UNIT NUMBER > 0 MONTH 3 EMPLOYMENT	1,800,327	100.00	1,811,033	-0.59
	17,125	14.58	17,020	0.61
	588,669	32.69	607,443	-3.09

SECTION 1 - CHARACTERISTICS BY MEEI CODE

MULTI-ESTABLISHMENT EMPLOYER INDICATOR

# RECORDS WITH MEEI 1 - SINGLE UNITS MONTH 3 EMPLOYMENT	98,811	84.16	97,265	1.58
# RECORDS WITH MEEI 2 - MULTI-UNIT MASTER RECORDS MONTH 3 EMPLOYMENT	1,179,145	65.49	1,181,126	-0.16
# RECORDS WITH MEEI 3 - SUB-UNIT RECORDS MONTH 3 EMPLOYMENT	1,332	1.13	1,330	0.15
# RECORDS WITH MEEI 4 - MULTI-ESTAB EMPL REPORTING AS A SINGLE MONTH 3 EMPLOYMENT	588,250	32.67	607,441	-3.15
# RECS WITH MEEI 5 - COMBINATION OF ESTAB AS ONE SUB-UNIT MONTH 3 EMPLOYMENT	17,124	14.58	17,019	0.61
# RECS WITH MEEI 6 - MULTI RPTING AS SNGL (BELOW EMPL LEVEL) MONTH 3 EMPLOYMENT	587,388	32.62	606,121	-3.09
	71	0.06	57	24.56
	29,171	1.62	19,116	52.59
	1	0.00	1	0.00
	1,281	0.07	1,322	-3.10
	62	0.05	62	0.00
	3,342	0.18	3,348	-0.17

CONTINUOUS UNIT RECORDS, BY MEEI CODE

# CONTINUOUS RECS WITH MEEI 1 - SINGLE UNITS MONTH 3 EMPLOYMENT	94,887	80.82	94,464	0.44
# CONTINUOUS RECS WITH MEEI 2 - MULTI-UNIT MASTER RECORDS MONTH 3 EMPLOYMENT	1,154,020	64.10	1,166,356	-1.05
# CONTINUOUS RECS WITH MEEI 3 - SUB-UNIT MONTH 3 EMPLOYMENT	1,316	1.12	1,326	-0.75
# CONTINUOUS RECS WITH MEEI 4 - MULTI REPORTING AS A SINGLE MONTH 3 EMPLOYMENT	583,597	32.41	606,691	-3.80
# CONTINUOUS RECS WITH MEEI 5 - COMBINATION AS ONE SUB-UNIT MONTH 3 EMPLOYMENT	16,663	14.19	16,707	-0.26
# CONTINUOUS RECS WITH MEEI 6 - MULTI RPTG AS SNGL (LOW EMPL) MONTH 3 EMPLOYMENT	575,196	31.94	597,022	-3.65
	70	0.05	55	27.27
	28,897	1.60	18,926	52.68
	1	0.00	1	0.00
	1,281	0.07	1,322	-3.10
	61	0.05	61	0.00
	3,331	0.18	3,344	-0.38
# CONTINUOUS RECS EXCLUDING MEEI 2 (MASTER RECORDS) MONTH 3 EMPLOYMENT	111,682	95.12	111,288	0.35
	1,762,725	97.91	1,786,970	-1.35

	CURRENT QTR TOT	% OF CURR TOTAL RECS	PREV.QTR TOTAL	% CHG
RECORDS DROPPED, BY MEEI CODE				
# RECORDS DROPPED WITH MEEI 1 SINGLE UNITS	2,539	2.16	1,563	62.44
MONTH 3 EMPLOYMENT	13,545	0.75	6,407	111.40
# RECORDS DROPPED WITH MEEI 2 MULTI-UNIT MASTER RECS	18	0.01	10	80.00
MONTH 3 EMPLOYMENT	2,892	0.16	947	205.38
# RECORDS DROPPED WITH MEEI 3 SUB-UNIT	299	0.25	191	56.54
MONTH 3 EMPLOYMENT	18,466	1.02	6,153	200.11
# RECORDS DROPPED WITH MEEI 4 MULTI REPORTING AS SINGLE	1	0.00	0	
MONTH 3 EMPLOYMENT	1,845	0.10	0	
# RECORDS DROPPED W/MEEI 5 COMBINATION AS ONE SUB-UNIT	0	0.00	0	
MONTH 3 EMPLOYMENT	0	0.00	0	
# RECS DROPPED W/MEEI 6 MULTI REPORTING AS SINGLE (LOW EMPL)	2	0.00	1	100.00
MONTH 3 EMPLOYMENT	29	0.00	0	
# RECORDS DROPPED EXCLUDING MEEI 2 (MASTER RECORDS)	2,841	2.41	1,755	61.88
MONTH 3 EMPLOYMENT	33,885	1.88	12,560	169.78
# RECORDS DROPPED WITH ALL MEEI CODES	2,859	2.43	1,765	61.98
MONTH 3 EMPLOYMENT	36,777	2.04	13,507	172.28
NEW RECORDS, BY MEEI CODE				
# NEW RECORDS WITH MEEI 1 - SINGLE UNITS	3,924	3.34	2,801	40.09
MONTH 3 EMPLOYMENT	25,125	1.39	14,770	70.10
# NEW RECORDS WITH MEEI 2 - MULTI-UNIT MASTER RECORDS	16	0.01	4	300.00
MONTH 3 EMPLOYMENT	4,653	0.25	750	520.40
# NEW RECORDS WITH MEEI 3 - SUB-UNIT	461	0.39	312	47.75
MONTH 3 EMPLOYMENT	12,192	0.67	9,099	33.99
# NEW RECORDS WITH MEEI 4 - MULTI REPORTING AS A SINGLE	1	0.00	2	-50.00
MONTH 3 EMPLOYMENT	274	0.01	190	44.21
# NEW RECORDS WITH MEEI 5 - COMBINATION AS ONE SUB-UNIT	0	0.00	0	
MONTH 3 EMPLOYMENT	0	0.00	0	
# NEW RECS WITH MEEI 6 - MULTI REPORTING AS SINGLE (LOW EMPL)	1	0.00	1	0.00
MONTH 3 EMPLOYMENT	11	0.00	4	175.00
# NEW RECORDS EXCLUDING MEEI 2 (MASTER RECORDS)	4,387	3.73	3,116	40.78
MONTH 3 EMPLOYMENT	37,602	2.08	24,063	56.26

EXHIBIT 13F (continued)

DATE: MM/DD/YYYY TIME: 06:06:06 PM		(STATE)			PAGE	3
INITIAL RUN YYYY/Q		EQUI DATA COUNTS - TABLE 3				
BUREAU OF LABOR STATISTICS - EQUI PROCESSING						
		CURRENT	% OF CURR	PREV.QTR		
		QTR TOT	TOTAL RECS	TOTAL	% CHG	

SECTION 2 - OTHER IDENTIFICATION INFORMATION AND CHARACTERISTICS						
PREDECESSOR / SUCCESSOR						

#	RECORDS WITH VALID PREDECESSOR UI ACCOUNT# AND RUN	31,648	26.95	31,023	2.01	
#	RECORDS WITH PREDECESSOR UI ACCOUNT# AND RUN ALL 9	1	0.00	1	0.00	
#	RECORDS WITH VALID PREDECESSOR UI ACCOUNT# AND WITH PREDECESSOR RUN = 99999	5	0.00	4	25.00	
#	RECORDS WITH VALID SUCCESSOR UI ACCOUNT# AND RUN	1,583	1.34	1,733	-8.65	
#	RECORDS WITH SUCCESSOR UI ACCOUNT# AND RUN ALL 9	2	0.00	2	0.00	
#	RECORDS WITH VALID SUCCESSOR UI ACCOUNT# AND WITH SUCCESSOR RUN = 99999	7	0.00	4	75.00	
NAICS						

**	# RECS WITH VALID NAICS CODES (EXCL 999999)	112,333	96.78	110,341	1.80	
**	# RECORDS WITH NAICS 999999	3,736	3.21	4,063	-8.04	
**	MONTH 3 EMPLOYMENT	9,338	0.51	10,203	-8.47	
**	# RECORDS WITH NAICS 999999 & COUNTY 999	910	0.78	1,043	-12.75	
**	MONTH 3 EMPLOYMENT	1,784	0.09	2,176	-18.01	
SIC						

**	# RECS WITH SPECIFIC SIC CODES (EXCLUDING 9999 & EXCEPTIONS)	78,912	67.98	80,527	-2.00	
**	# RECORDS WITH SIC 9999	32,498	27.99	29,176	11.38	
**	MONTH 3 EMPLOYMENT	237,822	13.20	211,404	12.49	
***	# MASTER RECORDS WITH SPECIFIC SIC CODES	1,087	81.60	1,104	-1.53	
SIC 4-DIGIT CODING EXCEPTIONS						

**	SIC 0740	228	0.19	232	-1.72	
**	SIC 0780	609	0.52	619	-1.61	
**	SIC 5810	3,822	3.29	3,850	-0.72	
**	# RECORDS WITH SIC CODING EXCEPTIONS	4,659	4.01	4,701	-0.89	

** COUNTS AND PERCENTAGES EXCLUDE MASTER RECORDS (MEEI = 2)						
*** COUNTS AND PERCENTAGES INCLUDE MASTER RECORDS ONLY						
OTHER COUNTS AND PERCENTAGES INCLUDE ALL ACTIVE CURRENT QUARTER RECORDS						

EXHIBIT 13F (continued)

DATE: MM/DD/YYYY TIME: 06:06:06 PM		(STATE)			PAGE	4
INITIAL RUN YYYY/Q		EQUI DATA COUNTS - TABLE 3				
BUREAU OF LABOR STATISTICS - EQUI PROCESSING						
		CURRENT	% OF CURR	PREV.QTR		
		QTR TOT	TOTAL RECS	TOTAL	% CHG	

LOCATION						

**	# RECORDS WITH VALID COUNTY CODES (EXCL 000, 900, 995-999)	105,184	90.62	103,870	1.26	
**	MONTH 3 EMPLOYMENT	1,732,751	96.24	1,749,863	-0.97	
**	# RECORDS WITH COUNTY CODE 995/999 COMBINED	10,881	9.37	10,531	3.32	
**	MONTH 3 EMPLOYMENT	67,557	3.75	61,150	10.47	
**	# RECORDS WITH COUNTY CODE 995 (STATEWIDE/MULTI-COUNTY)	546	0.47	512	6.64	
**	MONTH 3 EMPLOYMENT	17,210	0.95	10,423	65.11	
**	# RECORDS WITH COUNTY CODE 996 (FOREIGN)	1	0.00	1	0.00	
**	MONTH 3 EMPLOYMENT	17	0.00	18	-5.55	
**	# RECORDS WITH COUNTY CODE 998 (OUT OF STATE)	3	0.00	2	50.00	
**	MONTH 3 EMPLOYMENT	2	0.00	2	0.00	
**	# RECORDS WITH COUNTY CODE 999 (UNKNOWN)	10,335	8.90	10,019	3.15	
**	MONTH 3 EMPLOYMENT	50,347	2.79	50,727	-0.74	
**	# RECORDS WITH MEEI 2 AND COUNTY CODE 900 (MASTER)	329	0.28	310	6.12	
OWNERSHIP						

**	# RECORDS WITH OWNERSHIP 1 (FEDERAL GOVERNMENT)	654	0.56	646	1.23	
**	MONTH 3 EMPLOYMENT	28,350	1.57	28,200	0.53	
**	# RECORDS WITH OWNERSHIP 2 (STATE GOVERNMENT)	850	0.73	850	0.00	
**	MONTH 3 EMPLOYMENT	89,338	4.96	89,338	0.00	
**	# RECORDS WITH OWNERSHIP 3 (LOCAL GOVERNMENT)	1,775	1.52	1,784	-0.50	
**	MONTH 3 EMPLOYMENT	204,856	11.37	203,681	0.57	
**	# RECORDS WITH OWNERSHIP 5 (PRIVATE INDUSTRY)	112,790	97.17	111,124	1.49	
**	MONTH 3 EMPLOYMENT	1,477,783	82.08	1,489,814	-0.80	
EI ACCOUNT NUMBER						

	# RECORDS WITH USABLE EIN	116,819	99.50	115,173	1.42	
	# RECORDS WITH UNUSABLE EIN	0	0.00	0		
	# RECORDS WITH ZERO-FILLED (UNKNOWN) EIN	582	0.49	561	3.74	
*	# FEDERAL GOVT (OWNERSHIP 1) RECS WITH USABLE EIN	685	100.00	676	1.33	
*	# FEDERAL GOVT RECS WITH ZERO-FILLED EIN	0	0.00	0		
*	# STATE GOVT (OWN 2) RECS WITH USABLE EIN	874	99.77	874	0.00	
*	# STATE GOVT RECS WITH ZERO-FILLED EIN	2	0.22	2	0.00	
*	# LOCAL GOVT (OWN 3) RECS WITH USABLE EIN	1,850	99.56	1,860	-0.53	
*	# LOCAL GOVT RECS WITH ZERO-FILLED EIN	8	0.43	8	0.00	
*	# PRIVATE (OWN 5) RECS WITH USABLE EIN	113,410	99.49	111,763	1.47	
*	# PRIVATE RECS WITH ZERO-FILLED EIN	572	0.50	551	3.81	
*	# PRIVATE RECS WITH ZERO-FILLED EIN AND MONTH 3 EMP 25 TO 50	1	0.00	4	-75.00	
*	# PRIVATE RECS WITH ZERO-FILLED EIN AND MONTH 3 EMP > 50	1	0.00	3	-66.66	

* PERCENTAGES ARE BASED ON TOTAL FOR RESPECTIVE OWNERSHIPS						
** COUNTS AND PERCENTAGES EXCLUDE MASTER RECORDS (MEEI = 2)						
OTHER COUNTS AND PERCENTAGES INCLUDE ALL ACTIVE CURRENT QUARTER RECORDS						

EXHIBIT 13F (continued)

DATE: MM/DD/YYYY TIME: 06:06:06 PM		(STATE)		PAGE 5	
INITIAL RUN YYYY/Q		EQUI DATA COUNTS - TABLE 3			
BUREAU OF LABOR STATISTICS - EQUI PROCESSING					
		CURRENT	% OF CURR	PREV.QTR	
		QTR TOT	TOTAL RECS	TOTAL	% CHG

AUXILIARY					

**	# RECORDS WITH AUXILIARY CODE 0 (UNKNOWN)	1	0.00	0	
**	MONTH 3 EMPLOYMENT	121	0.00	0	
**	# RECORDS WITH AUX CODE 5 (NOT AN AUXILIARY UNIT)	115,777	99.74	114,151	1.42
**	MONTH 3 EMPLOYMENT	1,785,718	99.18	1,797,307	-0.64
**	# RECORDS WITH AUX CODE 8 (AUXILIARY UNIT)	291	0.25	253	15.01
**	MONTH 3 EMPLOYMENT	14,488	0.80	13,726	5.55
DATES					

	# RECORDS WITH VALID SETUP DATE	108,323	92.26	106,455	1.75
	# RECORDS WITH VALID INITIAL LIABILITY DATE	117,401	100.00	115,734	1.44
	# RECORDS WITH VALID END OF LIABILITY (EOL) DATE	4,531	3.85	4,938	-8.24
	# RECORDS WITH VALID REACTIVATION DATE	9,009	7.67	8,842	1.88
	# RECORDS WITH REACTIVATION DATE LATER THAN EOL DATE	3,659	3.11	3,423	6.89
	# RECORDS WITH EOL DATE LATER THAN REACTIVATION DATE	60	0.05	122	-50.81
ARS YEAR 2005 AND RESPONSE CODES					

	# RECS WITH CURRENT ARS YEAR = 2005 & NUMERIC RESPONSE CODE	33,242	28.31	33,598	-1.05
	# RECS WITH RC 41 (NO CCS CHANGES)	21,986	18.72	22,227	-1.08
	# RECS WITH RC 42 (INCORRECT/CORRECT)	468	0.39	445	5.16
	# RECS WITH RC 46 (ARS CCS CHANGE)	2,351	2.00	2,961	-20.60
	# RECS WITH RC 50 (NON-ARS CCS CHANGE)	427	0.36	302	41.39
	# RECS WITH RC 63 (PO RETURN)	286	0.24	348	-17.81
	# RECS WITH RC 64 (OUT OF BUSINESS)	159	0.13	159	0.00
	# RECS WITH RC 65 (REFUSAL)	373	0.31	423	-11.82
	# RECS WITH RC 76 (CCS, NSTA SYSTEM-ASSIGNED)	0	0.00	0	0.00
	# RECS WITH RC 77 (NSTA SYSTEM-ASSIGNED)	0	0.00	0	0.00
	# RECS WITH RC 98 (CARRYOVER OOB)	2,014	1.71	3,229	-37.62
CES INDICATOR					

**	# RECORDS WITH CES INDICATOR C (ON CES REGISTRY)	6,314	5.43	6,401	-1.35
	# RECS WITH CES INDICATOR INVALID (RESET TO BLANK)	0	0.00	0	

** COUNTS AND PERCENTAGES EXCLUDE MASTER RECORDS (MEEI = 2)					
OTHER COUNT AND PERCENTAGES INCLUDE ALL ACTIVE CURRENT QUARTER RECORDS					

EXHIBIT 13F (continued)

DATE: MM/DD/YYYY TIME: 06:06:06 PM		(STATE)		PAGE	
INITIAL RUN YYYY/Q		EQUI DATA COUNTS - TABLE 3			
BUREAU OF LABOR STATISTICS - EQUI PROCESSING					
		CURRENT	% OF CURR	PREV.QTR	
		QTR TOT	TOTAL RECS	TOTAL	% CHG
DATA SOURCE					
**	# RECORDS WITH DATA SOURCE = C (LOADED USING EDI JOB)	2,765	2.38	2,610	5.93
**	MONTH 3 EMPLOYMENT	79,059	4.39	74,582	6.00
**	# RECORDS WITH DATA SOURCE = E (NORMALLY COLLECTED BY EDI CTR)	335	0.28	293	14.33
**	MONTH 3 EMPLOYMENT	4,528	0.25	4,901	-7.61
**	# RECORDS WITH DATA SOURCE = Q (STATE QCR WEB COLLECTION)	0	0.00	0	
**	MONTH 3 EMPLOYMENT	0	0.00	0	
**	# RECORDS WITH DATA SOURCE = R (REGISTERED TO REPORT VIA MWR WEB)	0	0.00	0	
**	MONTH 3 EMPLOYMENT	0	0.00	0	
**	# RECORDS WITH DATA SOURCE = S (STATE MAGNETIC MEDIA)	0	0.00	0	
**	MONTH 3 EMPLOYMENT	0	0.00	0	
**	# RECORDS WITH DATA SOURCE = W (MWR WEB COLLECTION)	0	0.00	0	
**	MONTH 3 EMPLOYMENT	0	0.00	0	
**	# RECORDS WITH DATA SOURCE = X (FUTURE USE)	0	0.00	0	
**	MONTH 3 EMPLOYMENT	0	0.00	0	
**	# RECORDS WITH DATA SOURCE = BLANK (OTHER)	112,969	97.32	111,501	1.31
**	MONTH 3 EMPLOYMENT	1,716,740	95.35	1,731,550	-0.85
SPECIAL INDICATOR					
**	# RECORDS WITH INDICATOR = T (TRIBAL COUNCIL)	2	0.00	2	0.00
**	MONTH 3 EMPLOYMENT	40	0.00	31	29.03
**	# RECORDS WITH INDICATOR = L (STAFF IS LEASED)	0	0.00	0	
**	MONTH 3 EMPLOYMENT	0	0.00	0	
**	# RECORDS WITH INDICATOR INVALID (WILL BE SET TO BLANK)	0	0.00	0	
REPORTING CHANGE INDICATOR					
****	# RECORDS WITH RCI = 1 (CHANGE IN REPORTING)	0	0.00	0	
****	MONTH 3 EMPLOYMENT	0	0.00	0	
****	# RECORDS WITH RCI = 0 (UNKNOWN, OR NO CHANGE)	100,276	100.00	98,714	1.58
****	MONTH 3 EMPLOYMENT	1,799,908	100.00	1,811,031	-0.61
****	# RECORDS WITH RCI INVALID (WILL SET TO 0)	0	0.00	0	
COMMENTS					
	# RECORDS WITH ONE COMMENT CODE ONLY	721	0.61	719	0.27
	# RECORDS WITH TWO COMMENT CODES ONLY	123	0.10	48	156.25
	# RECORDS WITH THREE COMMENT CODES ONLY	8	0.00	2	300.00
	# RECORDS WITH NARRATIVE COMMENT & COMMENT CODE(S)	123	0.10	38	223.68
AGENT CODE					
****	# RECORDS WITH NON-BLANK AGENT CODES	0	0.00	0	
****	MONTH 3 EMPLOYMENT	0	0.00	0	

**	COUNTS AND PERCENTAGES EXCLUDE MASTER RECORDS (MEEI = 2)				
****	COUNTS AND PERCENTAGES INCLUDE SINGLES AND MASTERS ONLY (MEEI = 1, 2, 4, & 6)				
	OTHER COUNTS AND PERCENTAGES INCLUDE ALL ACTIVE CURRENT QUARTER RECORDS				

EXHIBIT 13F (continued)

DATE: MM/DD/YYYY TIME: 06:06:06 PM		(STATE)		PAGE	
INITIAL RUN YYYY/Q		EQUI DATA COUNTS - TABLE 3			
BUREAU OF LABOR STATISTICS - EQUI PROCESSING					
		CURRENT	% OF CURR	PREV.QTR	
		QTR TOT	TOTAL RECS	TOTAL	% CHG
SECTION 3 - EMPLOYMENT AND WAGE INFORMATION					
**	# RECORDS WITH ZERO EMPLOYMENT ALL 3 MONTHS	13,252	11.41	11,820	12.11
**	# RECORDS WITH ZERO EMPLOYMENT - 1ST MONTH	16,147	13.91	14,329	12.68
**	# RECORDS WITH ZERO EMPLOYMENT - 2ND MONTH	15,751	13.57	14,477	8.80
**	# RECORDS WITH ZERO EMPLOYMENT - 3RD MONTH	16,113	13.88	14,233	13.20
**	# RECORDS WITH ZERO WAGES	12,156	10.47	10,730	13.28
**	# RECS WITH ZERO WAGES AND ZERO EMPLOYMENT ALL 3 MONTH	11,964	10.30	10,534	13.57
SUMMARY OF THE EMPLOYMENT AND WAGES INDICATORS					

EMPLOYMENT INDICATORS					

**	# RECS WITH REPORTED DATA - R OR BLANK,C,D,L	92,408	79.61	93,972	-1.66
**	MONTH 3 EMPLOYMENT	1,584,864	88.03	1,595,592	-0.67
**	# RECS WITH IMPUTED DATA - A,E,H,W	8,929	7.69	6,586	35.57
**	MONTH 3 EMPLOYMENT	33,889	1.88	32,841	3.19
**	# RECS WITH MISSING DATA - M,N	10,537	9.07	9,525	10.62
**	MONTH 3 EMPLOYMENT	0	0.00	0	0.00
**	# RECS WITH PRORATED DATA - P	4,195	3.61	4,321	-2.91
**	MONTH 3 EMPLOYMENT	181,574	10.08	182,600	-0.56
WAGES INDICATORS					

**	# RECS WITH REPORTED DATA - R OR BLANK,C,L	93,648	80.68	94,718	-1.12
**	TOTAL WAGES	12,448,145,927	87.65	13,571,827,171	-8.27
**	# RECS WITH IMPUTED DATA - E,H,W	7,501	6.46	5,562	34.86
**	TOTAL WAGES	171,944,671	1.21	137,985,437	24.61
**	# RECS WITH MISSING DATA - M,N	10,448	9.00	9,406	11.07
**	TOTAL WAGES	0	0.00	0	0.00
**	# RECS WITH PRORATED DATA - P	4,472	3.85	4,718	-5.21
**	TOTAL WAGES	1,580,693,720	11.13	1,685,382,592	-6.21

EMPLOYMENT INDICATORS - ALL OWNERSHIPS:					

1ST MONTH:					
**	# RECS WITH R OR BLANK - DATA REPORTED	90,454	77.93	91,896	-1.56
**	MONTH 3 EMPLOYMENT	1,545,168	85.82	1,554,312	-0.58
**	# RECS WITH A - DATA ESTIMATED FROM ACES	2	0.00	2	0.00
**	MONTH 3 EMPLOYMENT	1,043	0.05	1,161	-10.16
**	# RECS WITH C - DATA CHANGED / RE-REPORTED	1,903	1.63	2,068	-7.97
**	MONTH 3 EMPLOYMENT	38,433	2.13	40,747	-5.67

** COUNTS AND PERCENTAGES EXCLUDE MASTER RECORDS (MEEI = 2)					

EXHIBIT 13F (continued)

DATE: MM/DD/YYYY		TIME: 06:06:06 PM		(STATE)		PAGE		8	
INITIAL RUN		YYYY/Q		EQUI DATA COUNTS - TABLE 3					
BUREAU OF LABOR STATISTICS - EQUI PROCESSING									
		CURRENT	% OF CURR	PREV.QTR					
		QTR TOT	TOTAL RECS	TOTAL			% CHG		

**	# RECS WITH D - DATA REPORTED FROM MISSING DATA NOTICE	0	0.00	0					
**	MONTH 3 EMPLOYMENT	0	0.00	0					
**	# RECS WITH E - DATA IMPUTED/PRORATED FR IMPUTED MASTER	8,935	7.69	6,587			35.64		
**	MONTH 3 EMPLOYMENT	33,040	1.83	31,747			4.07		
**	# RECS WITH H - DATA HAND-IMPUTED	0	0.00	0					
**	MONTH 3 EMPLOYMENT	0	0.00	0					
**	# RECS WITH L - DATA REPORTED LATE	0	0.00	0					
**	MONTH 3 EMPLOYMENT	0	0.00	0					
**	# RECS WITH M - DATA MISSING	10,571	9.10	9,528			10.94		
**	MONTH 3 EMPLOYMENT	1,043	0.05	498			109.43		
**	# RECS WITH N - DATA ZERO PENDING RESOLUTION OF DELINQUENT	0	0.00	0					
**	MONTH 3 EMPLOYMENT	0	0.00	0					
**	# RECS WITH P - DATA PRORATED FROM REPORTED MASTER	4,204	3.62	4,323			-2.75		
**	MONTH 3 EMPLOYMENT	181,600	10.08	182,568			-0.53		
***	# RECS WITH S - DATA FOR MASTER SUMMED FROM WORKSITES	1	0.07	0					
***	MONTH 3 EMPLOYMENT	953	0.16	0					
**	# RECS WITH W - DATA IMPUTED FROM WAGE RECORDS	0	0.00	0					
**	MONTH 3 EMPLOYMENT	0	0.00	0					
**	# RECS WITH X - DATA SET TO 0 PENDING FURTHER ACTION	0	0.00	0					
**	MONTH 3 EMPLOYMENT	0	0.00	0					
2ND MONTH:									
**	# RECS WITH R OR BLANK - DATA REPORTED	90,467	77.94	91,917			-1.57		
**	MONTH 3 EMPLOYMENT	1,554,119	86.32	1,553,335			0.05		
**	# RECS WITH A - DATA ESTIMATED FROM ACES	2	0.00	2			0.00		
**	MONTH 3 EMPLOYMENT	1,043	0.05	1,161			-10.16		
**	# RECS WITH C - DATA CHANGED / RE-REPORTED	1,932	1.66	2,055			-5.98		
**	MONTH 3 EMPLOYMENT	30,499	1.69	41,910			-27.22		
**	# RECS WITH D - DATA REPORTED FROM MISSING DATA NOTICE	0	0.00	0					
**	MONTH 3 EMPLOYMENT	0	0.00	0					
**	# RECS WITH E - DATA IMPUTED/PRORATED FR IMPUTED MASTER	8,934	7.69	6,584			35.69		
**	MONTH 3 EMPLOYMENT	33,028	1.83	31,672			4.28		
**	# RECS WITH H - DATA HAND-IMPUTED	0	0.00	0					
**	MONTH 3 EMPLOYMENT	0	0.00	0					
**	# RECS WITH L - DATA REPORTED LATE	0	0.00	0					
**	MONTH 3 EMPLOYMENT	0	0.00	0					
**	# RECS WITH M - DATA MISSING	10,534	9.07	9,522			10.62		
**	MONTH 3 EMPLOYMENT	64	0.00	387			-83.46		
**	# RECS WITH N - DATA ZERO PENDING RESOLUTION OF DELINQUENT	0	0.00	0					
**	MONTH 3 EMPLOYMENT	0	0.00	0					
**	# RECS WITH P - DATA PRORATED FROM REPORTED MASTER	4,200	3.61	4,324			-2.86		
**	MONTH 3 EMPLOYMENT	181,574	10.08	182,568			-0.54		
***	# RECS WITH S - DATA FOR MASTER SUMMED FROM WORKSITES	0	0.00	0					
***	MONTH 3 EMPLOYMENT	0	0.00	0					
**	# RECS WITH W - DATA IMPUTED FROM WAGE RECORDS	0	0.00	0					
**	MONTH 3 EMPLOYMENT	0	0.00	0					

** COUNTS AND PERCENTAGES EXCLUDE MASTER RECORDS (MEEI = 2)									
OTHER COUNTS AND PERCENTAGES INCLUDE ALL ACTIVE CURRENT QUARTER RECORDS									
*** COUNTS AND PERCENTAGES INCLUDE MASTER RECORDS ONLY									

EXHIBIT 13F (continued)

DATE: MM/DD/YYYY		TIME: 06:06:06 PM		(STATE)		PAGE		9	
INITIAL RUN		YYYY/Q		EQUI DATA COUNTS - TABLE 3					
BUREAU OF LABOR STATISTICS - EQUI PROCESSING									
		CURRENT	% OF CURR	PREV.QTR					
		QTR TOT	TOTAL RECS	TOTAL	% CHG				
**	# RECS WITH X - DATA SET TO 0 PENDING FURTHER ACTION	0	0.00	0					
**	MONTH 3 EMPLOYMENT	0	0.00	0					
3RD MONTH:									
**	# RECS WITH R OR BLANK - DATA REPORTED	90,389	77.87	91,880					-1.62
**	MONTH 3 EMPLOYMENT	1,546,929	85.92	1,553,499					-0.42
**	# RECS WITH A - DATA ESTIMATED FROM ACES	2	0.00	2					0.00
**	MONTH 3 EMPLOYMENT	1,043	0.05	1,161					-10.16
**	# RECS WITH C - DATA CHANGED / RE-REPORTED	2,019	1.73	2,092					-3.48
**	MONTH 3 EMPLOYMENT	37,935	2.10	42,093					-9.87
**	# RECS WITH D - DATA REPORTED FROM MISSING DATA NOTICE	0	0.00	0					
**	MONTH 3 EMPLOYMENT	0	0.00	0					
**	# RECS WITH E - DATA IMPUTED/PRORATED FR IMPUTED MASTER	8,927	7.69	6,584					35.58
**	MONTH 3 EMPLOYMENT	32,846	1.82	31,680					3.68
**	# RECS WITH H - DATA HAND-IMPUTED	0	0.00	0					
**	MONTH 3 EMPLOYMENT	0	0.00	0					
**	# RECS WITH L - DATA REPORTED LATE	0	0.00	0					
**	MONTH 3 EMPLOYMENT	0	0.00	0					
**	# RECS WITH M - DATA MISSING	10,537	9.07	9,525					10.62
**	MONTH 3 EMPLOYMENT	0	0.00	0					
**	# RECS WITH N - DATA ZERO PENDING RESOLUTION OF DELINQUENT	0	0.00	0					
**	MONTH 3 EMPLOYMENT	0	0.00	0					
**	# RECS WITH P - DATA PRORATED FROM REPORTED MASTER	4,195	3.61	4,321					-2.91
**	MONTH 3 EMPLOYMENT	181,574	10.08	182,600					-0.56
***	# RECS WITH S - DATA FOR MASTER SUMMED FROM WORKSITES	0	0.00	0					
***	MONTH 3 EMPLOYMENT	0	0.00	0					
**	# RECS WITH W - DATA IMPUTED FROM WAGE RECORDS	0	0.00	0					
**	MONTH 3 EMPLOYMENT	0	0.00	0					
**	# RECS WITH X - DATA SET TO 0 PENDING FURTHER ACTION	0	0.00	0					
**	MONTH 3 EMPLOYMENT	0	0.00	0					
* EMPLOYMENT INDICATORS - FEDERAL OWNERSHIP (OWN 1)									

3RD MONTH:									
**	# RECS WITH R OR BLANK - DATA REPORTED	512	78.28	501					2.19
**	MONTH 3 EMPLOYMENT	26,501	93.47	26,518					-0.06
**	# RECS WITH A - DATA ESTIMATED FROM ACES	0	0.00	0					
**	MONTH 3 EMPLOYMENT	0	0.00	0					
**	# RECS WITH C - DATA CHANGED / RE-REPORTED	0	0.00	1					-100.00
**	MONTH 3 EMPLOYMENT	0	0.00	379					-100.00
**	# RECS WITH D - DATA REPORTED FROM MISSING DATA NOTICE	0	0.00	0					
**	MONTH 3 EMPLOYMENT	0	0.00	0					
**	# RECS WITH E - DATA IMPUTED/PRORATED FR IMPUTED MASTER	4	0.61	15					-73.33

* PERCENTAGES IN SECTION 3 ARE BASED ON TOTAL FOR RESPECTIVE OWNERSHIPS									
** COUNTS AND PERCENTAGES EXCLUDE MASTER RECORDS (MEEI = 2)									
*** COUNTS AND PERCENTAGES INCLUDE MASTER RECORDS ONLY									

EXHIBIT 13F (continued)

DATE: MM/DD/YYYY		TIME: 06:06:06 PM		(STATE)		PAGE 10	
INITIAL RUN YYYY/Q		EQUI DATA COUNTS - TABLE 3					
BUREAU OF LABOR STATISTICS - EQUI PROCESSING							
		CURRENT	% OF CURR	PREV.QTR			
		QTR TOT	TOTAL RECS	TOTAL	% CHG		
**	MONTH 3 EMPLOYMENT	1,813	6.39	1,303	39.14		
**	# RECS WITH H - DATA HAND-IMPUTED	0	0.00	0			
**	MONTH 3 EMPLOYMENT	0	0.00	0			
**	# RECS WITH L - DATA REPORTED LATE	0	0.00	0			
**	MONTH 3 EMPLOYMENT	0	0.00	0			
**	# RECS WITH M - DATA MISSING	128	19.57	129	-0.77		
**	MONTH 3 EMPLOYMENT	0	0.00	0			
**	# RECS WITH N - DATA ZERO PENDING RESOLUTION OF DELINQUENT	0	0.00	0			
**	MONTH 3 EMPLOYMENT	0	0.00	0			
**	# RECS WITH P - DATA PRORATED FROM REPORTED MASTER	10	1.52	0			
**	MONTH 3 EMPLOYMENT	36	0.12	0			
***	# RECS WITH S - DATA FOR MASTER SUMMED FROM WORKSITES	0	0.00	0			
***	MONTH 3 EMPLOYMENT	0	0.00	0			
**	# RECS WITH W - DATA IMPUTED FROM WAGE RECORDS	0	0.00	0			
**	MONTH 3 EMPLOYMENT	0	0.00	0			
**	# RECS WITH X - DATA SET TO 0 PENDING FURTHER ACTION	0	0.00	0			
**	MONTH 3 EMPLOYMENT	0	0.00	0			
* EMPLOYMENT INDICATORS - STATE GOVERNMENT OWNERSHIP (OWN 2)							

3RD MONTH:							
**	# RECS WITH R OR BLANK - DATA REPORTED	182	21.41	258	-29.45		
**	MONTH 3 EMPLOYMENT	39,760	44.50	53,130	-25.16		
**	# RECS WITH A - DATA ESTIMATED FROM ACES	0	0.00	0			
**	MONTH 3 EMPLOYMENT	0	0.00	0			
**	# RECS WITH C - DATA CHANGED / RE-REPORTED	3	0.35	12	-75.00		
**	MONTH 3 EMPLOYMENT	1,224	1.37	4,000	-69.40		
**	# RECS WITH D - DATA REPORTED FROM MISSING DATA NOTICE	0	0.00	0			
**	MONTH 3 EMPLOYMENT	0	0.00	0			
**	# RECS WITH E - DATA IMPUTED/PRORATED FR IMPUTED MASTER	0	0.00	0			
**	MONTH 3 EMPLOYMENT	0	0.00	0			
**	# RECS WITH H - DATA HAND-IMPUTED	0	0.00	0			
**	MONTH 3 EMPLOYMENT	0	0.00	0			
**	# RECS WITH L - DATA REPORTED LATE	0	0.00	0			
**	MONTH 3 EMPLOYMENT	0	0.00	0			
**	# RECS WITH M - DATA MISSING	2	0.23	2	0.00		
**	MONTH 3 EMPLOYMENT	0	0.00	0			
**	# RECS WITH N - DATA ZERO PENDING RESOLUTION OF DELINQUENT	0	0.00	0			
**	MONTH 3 EMPLOYMENT	0	0.00	0			
**	# RECS WITH P - DATA PRORATED FROM REPORTED MASTER	663	78.00	578	14.70		
**	MONTH 3 EMPLOYMENT	48,354	54.12	32,208	50.13		
***	# RECS WITH S - DATA FOR MASTER SUMMED FROM WORKSITES	0	0.00	0			
***	MONTH 3 EMPLOYMENT	0	0.00	0			
**	# RECS WITH W - DATA IMPUTED FROM WAGE RECORDS	0	0.00	0			

* PERCENTAGES IN SECTION 3 ARE BASED ON TOTAL FOR RESPECTIVE OWNERSHIPS							
** COUNTS AND PERCENTAGES EXCLUDE MASTER RECORDS (MEEI = 2)							
*** COUNTS AND PERCENTAGES INCLUDE MASTER RECS ONLY							

EXHIBIT 13F (continued)

DATE: MM/DD/YYYY		TIME: 06:06:06 PM		(STATE)		PAGE		11	
INITIAL RUN		YYYY/Q		EQUI DATA COUNTS - TABLE 3					
BUREAU OF LABOR STATISTICS - EQUI PROCESSING									
				CURRENT	% OF CURR	PREV.QTR			
				QTR TOT	TOTAL RECS	TOTAL	% CHG		

**	MONTH 3 EMPLOYMENT			0	0.00	0			
**	# RECS WITH X - DATA SET TO 0 PENDING FURTHER ACTION			0	0.00	0			
**	MONTH 3 EMPLOYMENT			0	0.00	0			
* EMPLOYMENT INDICATORS - LOCAL GOVERNMENT OWNERSHIP (OWN 3)									

3RD MONTH:									
**	# RECS WITH R OR BLANK - DATA REPORTED			1,532	86.30	1,624		-5.66	
**	MONTH 3 EMPLOYMENT	181,084		88.39		175,236		3.33	
**	# RECS WITH A - DATA ESTIMATED FROM ACES			0	0.00	0			
**	MONTH 3 EMPLOYMENT			0	0.00	0			
**	# RECS WITH C - DATA CHANGED / RE-REPORTED			15	0.84	20		-25.00	
**	MONTH 3 EMPLOYMENT	2,278		1.11		6,122		-62.78	
**	# RECS WITH D - DATA REPORTED FROM MISSING DATA NOTICE			0	0.00	0			
**	MONTH 3 EMPLOYMENT			0	0.00	0			
**	# RECS WITH E - DATA IMPUTED/PRORATED FR IMPUTED MASTER			12	0.67	5		140.00	
**	MONTH 3 EMPLOYMENT	1,586		0.77		2,984		-46.84	
**	# RECS WITH H - DATA HAND-IMPUTED			0	0.00	0			
**	MONTH 3 EMPLOYMENT			0	0.00	0			
**	# RECS WITH L - DATA REPORTED LATE			0	0.00	0			
**	MONTH 3 EMPLOYMENT			0	0.00	0			
**	# RECS WITH M - DATA MISSING			11	0.61	15		-26.66	
**	MONTH 3 EMPLOYMENT			0	0.00	0			
**	# RECS WITH N - DATA ZERO PENDING RESOLUTION OF DELINQUENT			0	0.00	0			
**	MONTH 3 EMPLOYMENT			0	0.00	0			
**	# RECS WITH P - DATA PRORATED FROM REPORTED MASTER			205	11.54	120		70.83	
**	MONTH 3 EMPLOYMENT	19,908		9.71		19,339		2.94	
***	# RECS WITH S - DATA FOR MASTER SUMMED FROM WORKSITES			0	0.00	0			
***	MONTH 3 EMPLOYMENT			0	0.00	0			
**	# RECS WITH W - DATA IMPUTED FROM WAGE RECORDS			0	0.00	0			
**	MONTH 3 EMPLOYMENT			0	0.00	0			
**	# RECS WITH X - DATA SET TO 0 PENDING FURTHER ACTION			0	0.00	0			
**	MONTH 3 EMPLOYMENT			0	0.00	0			
* EMPLOYMENT INDICATORS - PRIVATE OWNERSHIP (OWN 5)									

3RD MONTH:									
**	# RECS WITH R OR BLANK - DATA REPORTED			88,163	78.16	89,497		-1.49	
**	MONTH 3 EMPLOYMENT	1,299,584		87.94		1,298,615		0.07	
**	# RECS WITH A - DATA ESTIMATED FROM ACES			2	0.00	2		0.00	
**	MONTH 3 EMPLOYMENT			1,043	0.07	1,161		-10.16	
**	# RECS WITH C - DATA CHANGED / RE-REPORTED			2,001	1.77	2,059		-2.81	
**	MONTH 3 EMPLOYMENT	34,433		2.33		31,592		8.99	
**	# RECS WITH D - DATA REPORTED FROM MISSING DATA NOTICE			0	0.00	0			

* PERCENTAGES IN SECTION 3 ARE BASED ON TOTAL FOR RESPECTIVE OWNERSHIPS									
** COUNTS AND PERCENTAGES EXCLUDE MASTER RECORDS (MEEI = 2)									
*** COUNTS AND PERCENTAGES INCLUDE MASTER RECORDS ONLY									

EXHIBIT 13F (continued)

DATE: MM/DD/YYYY		TIME: 06:06:06 PM		(STATE)		PAGE		12	
INITIAL RUN		YYYY/Q		EQUI DATA COUNTS - TABLE 3					
BUREAU OF LABOR STATISTICS - EQUI PROCESSING									
		CURRENT	% OF CURR	PREV.QTR					
		QTR TOT	TOTAL RECS	TOTAL			% CHG		
**	MONTH 3 EMPLOYMENT	0	0.00	0					
**	# RECS WITH E - DATA IMPUTED/PRORATED FR IMPUTED MASTER	8,911	7.90	6,564			35.75		
**	MONTH 3 EMPLOYMENT	29,447	1.99	27,393			7.49		
**	# RECS WITH H - DATA HAND-IMPUTED	0	0.00	0					
**	MONTH 3 EMPLOYMENT	0	0.00	0					
**	# RECS WITH L - DATA REPORTED LATE	0	0.00	0					
**	MONTH 3 EMPLOYMENT	0	0.00	0					
**	# RECS WITH M - DATA MISSING	10,396	9.21	9,379			10.84		
**	MONTH 3 EMPLOYMENT	0	0.00	0					
**	# RECS WITH N - DATA ZERO PENDING RESOLUTION OF DELINQUENT	0	0.00	0					
**	MONTH 3 EMPLOYMENT	0	0.00	0					
**	# RECS WITH P - DATA PRORATED FROM REPORTED MASTER	3,317	2.94	3,623			-8.44		
**	MONTH 3 EMPLOYMENT	113,276	7.66	131,053			-13.56		
***	# RECS WITH S - DATA FOR MASTER SUMMED FROM WORKSITES	0	0.00	0					
***	MONTH 3 EMPLOYMENT	0	0.00	0					
**	# RECS WITH W - DATA IMPUTED FROM WAGE RECORDS	0	0.00	0					
**	MONTH 3 EMPLOYMENT	0	0.00	0					
**	# RECS WITH X - DATA SET TO 0 PENDING FURTHER ACTION	0	0.00	0					
**	MONTH 3 EMPLOYMENT	0	0.00	0					
		CURRENT	%OF CURR	PREV.QTR					
		QTR TOT	QTR TOT	TOTAL			% CHG		

TOTAL WAGES INDICATORS - ALL OWNERSHIP									

**	# RECS WITH R OR BLANK - DATA REPORTED	93,442	80.50	94,360			-0.97		
**	TOTAL WAGES	12,406,502,555	87.36	13,467,151,762			-7.87		
**	# RECS WITH C - DATA CHANGED / RE-REPORTED	206	0.17	358			-42.45		
**	TOTAL WAGES	41,643,372	0.29	104,675,409			-60.21		
**	# RECS WITH E - DATA IMPUTED/PRORATED FR IMPUTED MASTER	7,501	6.46	5,562			34.86		
**	TOTAL WAGES	171,944,671	1.21	137,985,437			24.61		
**	# RECS WITH H - DATA HAND-IMPUTED	0	0.00	0					
**	TOTAL WAGES	0	0.00	0					
**	# RECS WITH L - DATA REPORTED LATE	0	0.00	0					
**	TOTAL WAGES	0	0.00	0					
**	# RECS WITH M - DATA MISSING	10,447	9.00	9,406			11.06		
**	TOTAL WAGES	0	0.00	0					
**	# RECS WITH N - DATA ZERO PENDING RESOLUTION OF DELINQUENT	1	0.00	0					
**	TOTAL WAGES	0	0.00	0					
**	# RECS WITH P - DATA PRORATED FROM REPORTED MASTER	4,472	3.85	4,718			-5.21		
**	TOTAL WAGES	1,580,693,720	11.13	1,685,382,592			-6.21		
***	# RECS WITH S - DATA FOR MASTER SUMMED FROM WORKSITES	1	0.07	0					
***	TOTAL WAGES	219,620	0.00	0					
**	# RECS WITH W - DATA IMPUTED FROM WAGE RECORDS	0	0.00	0					
**	TOTAL WAGES	0	0.00	0					
**	# RECS WITH X - DATA SET TO 0 PENDING FURTHER ACTION	0	0.00	0					
**	TOTAL WAGES	0	0.00	0					

** COUNTS AND PERCENTAGES EXCLUDE MASTER RECORDS (MEEI = 2)									
*** COUNTS AND PERCENTAGES INCLUDE MASTER RECORDS ONLY									

EXHIBIT 13F (continued)

DATE: MM/DD/YYYY		TIME: 06:06:06 PM		(STATE)		PAGE		13	
INITIAL RUN		YYYY/Q		EQUI DATA COUNTS - TABLE 3					
BUREAU OF LABOR STATISTICS - EQUI PROCESSING									
		CURRENT	%OF CURR	PREV.QTR					
		QTR TOT	QTR TOT	TOTAL		% CHG			
* TOTAL WAGES INDICATORS - FEDERAL OWNERSHIPS (OWN 1)									

**	# RECS WITH R OR BLANK - DATA REPORTED	512	78.28	501		2.19			
**	TOTAL WAGES	334,019,818	91.17	340,521,849		-1.90			
**	# RECS WITH C - DATA CHANGED / RE-REPORTED	0	0.00	0					
**	TOTAL WAGES	0	0.00	0					
**	# RECS WITH E - DATA IMPUTED/PRORATED FR IMPUTED MASTER	4	0.61	16		-75.00			
**	TOTAL WAGES	31,826,786	8.68	17,083,304		86.30			
**	# RECS WITH H - DATA HAND-IMPUTED	0	0.00	0					
**	TOTAL WAGES	0	0.00	0					
**	# RECS WITH L - DATA REPORTED LATE	0	0.00	0					
**	TOTAL WAGES	0	0.00	0					
**	# RECS WITH M - DATA MISSING	128	19.57	129		-0.77			
**	TOTAL WAGES	0	0.00	0					
**	# RECS WITH N - DATA ZERO PENDING RESOLUTION OF DELINQUENT	0	0.00	0					
**	TOTAL WAGES	0	0.00	0					
**	# RECS WITH P - DATA PRORATED FROM REPORTED MASTER	10	1.52	0					
**	TOTAL WAGES	499,071	0.13	0					
***	# RECS WITH S - DATA FOR MASTER SUMMED FROM WORKSITES	1	3.22	0					
***	TOTAL WAGES	219,620	0.07	0					
**	# RECS WITH W - DATA IMPUTED FROM WAGE RECORDS	0	0.00	0					
**	TOTAL WAGES	0	0.00	0					
**	# RECS WITH X - DATA SET TO 0 PENDING FURTHER ACTION	0	0.00	0					
**	TOTAL WAGES	0	0.00	0					
* TOTAL WAGES INDICATORS - STATE GOVERNMENT OWNERSHIP (OWN 2)									

**	# RECS WITH R OR BLANK - DATA REPORTED	185	21.76	259		-28.57			
**	TOTAL WAGES	367,863,577	47.50	501,214,072		-26.60			
**	# RECS WITH C - DATA CHANGED / RE-REPORTED	0	0.00	11		-100.00			
**	TOTAL WAGES	0	0.00	27,824,682		-100.00			
**	# RECS WITH E - DATA IMPUTED/PRORATED FR IMPUTED MASTER	0	0.00	0					
**	TOTAL WAGES	0	0.00	0					
**	# RECS WITH H - DATA HAND-IMPUTED	0	0.00	0					
**	TOTAL WAGES	0	0.00	0					
**	# RECS WITH L - DATA REPORTED LATE	0	0.00	0					
**	TOTAL WAGES	0	0.00	0					
**	# RECS WITH M - DATA MISSING	2	0.23	2		0.00			
**	TOTAL WAGES	0	0.00	0					
**	# RECS WITH N - DATA ZERO PENDING RESOLUTION OF DELINQUENT	0	0.00	0					
**	TOTAL WAGES	0	0.00	0					
**	# RECS WITH P - DATA PRORATED FROM REPORTED MASTER	663	78.00	578		14.70			
**	TOTAL WAGES	406,505,324	52.49	253,960,496		60.06			
***	# RECS WITH S - DATA FOR MASTER SUMMED FROM WORKSITES	0	0.00	0					
***	TOTAL WAGES	0	0.00	0					

* PERCENTAGES IN SECTION 3 ARE BASED ON TOTAL FOR RESPECTIVE OWNERSHIPS									
** COUNTS AND PERCENTAGES EXCLUDE MASTER RECORDS (MEEI = 2)									
*** COUNTS AND PERCENTAGES INCLUDE MASTER RECORDS ONLY									

EXHIBIT 13F (continued)

DATE: MM/DD/YYYY		TIME: 06:06:06 PM		(STATE)		PAGE 14	
INITIAL RUN YYYY/Q		EQUI DATA COUNTS - TABLE 3					
BUREAU OF LABOR STATISTICS - EQUI PROCESSING							
		CURRENT	%OF CURR	PREV.QTR			
		QTR TOT	QTR TOT	TOTAL		% CHG	
**	# RECS WITH W - DATA IMPUTED FROM WAGE RECORDS	0	0.00	0			
**	TOTAL WAGES	0	0.00	0			
**	# RECS WITH X - DATA SET TO 0 PENDING FURTHER ACTION	0	0.00	0			
**	TOTAL WAGES	0	0.00	0			
* TOTAL WAGES INDICATORS - LOCAL GOVERNMENT OWNERSHIP (OWN 3)							

**	# RECS WITH R OR BLANK - DATA REPORTED	1,550	87.32	1,646		-5.83	
**	TOTAL WAGES	1,356,341,647	88.14	1,462,077,234		-7.23	
**	# RECS WITH C - DATA CHANGED / RE-REPORTED	0	0.00	0			
**	TOTAL WAGES	0	0.00	0			
**	# RECS WITH E - DATA IMPUTED/PRORATED FR IMPUTED MASTER	10	0.56	5		100.00	
**	TOTAL WAGES	16,607,514	1.07	21,398,998		-22.39	
**	# RECS WITH H - DATA HAND-IMPUTED	0	0.00	0			
**	TOTAL WAGES	0	0.00	0			
**	# RECS WITH L - DATA REPORTED LATE	0	0.00	0			
**	TOTAL WAGES	0	0.00	0			
**	# RECS WITH M - DATA MISSING	10	0.56	14		-28.57	
**	TOTAL WAGES	0	0.00	0			
**	# RECS WITH N - DATA ZERO PENDING RESOLUTION OF DELINQUENT	0	0.00	0			
**	TOTAL WAGES	0	0.00	0			
**	# RECS WITH P - DATA PRORATED FROM REPORTED MASTER	205	11.54	119		72.26	
**	TOTAL WAGES	165,748,000	10.77	177,111,500		-6.41	
***	# RECS WITH S - DATA FOR MASTER SUMMED FROM WORKSITES	0	0.00	0			
***	TOTAL WAGES	0	0.00	0			
**	# RECS WITH W - DATA IMPUTED FROM WAGE RECORDS	0	0.00	0			
**	TOTAL WAGES	0	0.00	0			
**	# RECS WITH X - DATA SET TO 0 PENDING FURTHER ACTION	0	0.00	0			
**	TOTAL WAGES	0	0.00	0			
* TOTAL WAGES INDICATORS - PRIVATE OWNERSHIP (OWN 5)							

**	# RECS WITH R OR BLANK - DATA REPORTED	91,195	80.85	91,954		-0.82	
**	TOTAL WAGES	10,348,277,513	89.81	11,163,338,607		-7.30	
**	# RECS WITH C - DATA CHANGED / RE-REPORTED	206	0.18	347		-40.63	
**	TOTAL WAGES	41,643,372	0.36	76,850,727		-45.81	
**	# RECS WITH E - DATA IMPUTED/PRORATED FR IMPUTED MASTER	7,487	6.63	5,541		35.12	
**	TOTAL WAGES	123,510,371	1.07	99,503,135		24.12	
**	# RECS WITH H - DATA HAND-IMPUTED	0	0.00	0			
**	TOTAL WAGES	0	0.00	0			
**	# RECS WITH L - DATA REPORTED LATE	0	0.00	0			
**	TOTAL WAGES	0	0.00	0			
**	# RECS WITH M - DATA MISSING	10,307	9.13	9,261		11.29	
**	TOTAL WAGES	0	0.00	0			

* PERCENTAGES IN SECTION 3 ARE BASED ON TOTAL FOR RESPECTIVE OWNERSHIPS							
** COUNTS AND PERCENTAGES EXCLUDE MASTER RECORDS (MEEI = 2)							
*** COUNTS AND PERCENTAGES INCLUDE MASTER RECORDS ONLY							

EXHIBIT 13F (continued)

DATE: MM/DD/YYYY		TIME: 06:06:06 PM		(STATE)		PAGE 15	
INITIAL RUN		YYYY/Q		EQUI DATA COUNTS - TABLE 3			
BUREAU OF LABOR STATISTICS - EQUI PROCESSING							
		CURRENT	%OF CURR	PREV.QTR			
		QTR TOT	QTR TOT	TOTAL		% CHG	
**	# RECS WITH N - DATA ZERO PENDING RESOLUTION OF DELINQUENT	1	0.00	0			
**	TOTAL WAGES	0	0.00	0			
**	# RECS WITH P - DATA PRORATED FROM REPORTED MASTER	3,594	3.18	4,021		-10.61	
**	TOTAL WAGES	1,007,941,325	8.74	1,254,310,596		-19.64	
***	# RECS WITH S - DATA FOR MASTER SUMMED FROM WORKSITES	0	0.00	0			
***	TOTAL WAGES	0	0.00	0			
**	# RECS WITH W - DATA IMPUTED FROM WAGE RECORDS	0	0.00	0			
**	TOTAL WAGES	0	0.00	0			
**	# RECS WITH X - DATA SET TO 0 PENDING FURTHER ACTION	0	0.00	0			
**	TOTAL WAGES	0	0.00	0			
**	# RECS WITH ALL 3 MOS EMPL IMP/MISS/PRO BUT WAGES REP	1,638	1.41	1,227		33.49	
**	# RECS WITH ALL 3 MOS EMPL IMP/MISS/PRO AND WAGES IMP/MISS/PRO	22,014	18.96	19,188		14.72	
**	# RECS WITH EMPL/WAGES IMPUTED FOR LAST 4 QTRS	2	0.00	2		0.00	
**	MONTH 3 EMPLOYMENT	322	0.01	284		13.38	
**	# RECS WITH EMPL/WAGES IMPUTED FOR LAST 5 QTRS	2	0.00	0		0.00	
**	MONTH 3 EMPLOYMENT	322	0.01	0		0.00	
**	# RECS WITH EMPL/WAGES IMPUTED FOR LAST 6 QTRS	0	0.00	0		0.00	
**	MONTH 3 EMPLOYMENT	0	0.00	0		0.00	
**	# RECS WITH EMPL/WAGES IMPUTED FOR LAST 7 QTRS	0	0.00	0		0.00	
**	MONTH 3 EMPLOYMENT	0	0.00	0		0.00	
**	# RECS WITH EMPL/WAGES EQUAL/UNCHANGED FOR 7 QTRS	5,074	4.37	4,610		10.06	
**	MONTH 3 EMPLOYMENT	2,128	0.11	2,338		-8.98	
**	# RECS WITH EMPL/WAGES IMPUTED, NEW BIRTHS	0	0.00	0		0.00	
**	MONTH 3 EMPLOYMENT	0	0.00	0		0.00	
SECTION 4 - ADDRESSES AND RELATED FIELDS							
		CURRENT	% OF CURR	PREV.QTR			
		QTR TOT	TOTAL RECS	TOTAL		% CHG	
COUNTS OF NON-BLANK ADDRESS LINES:							
	TRADE NAME ONLY	12	0.01	5		140.00	
	LEGAL NAME ONLY	4,639	3.95	4,772		-2.78	
	BOTH TRADE AND LEGAL NAMES	112,750	96.03	110,957		1.61	
**	# RECS WITH NON-BLANK, NON-ZERO TELEPHONE NUMBERS	110,022	93.71	108,376		1.51	
**	# RECS WITH NON-BLANK, NON-ZERO FAX NUMBERS	24,883	21.43	22,482		10.67	
**	# RECS WITH VALID PHYSICAL LOCATION BLOCK	80,755	69.57	81,008		-0.31	
**	MONTH 3 EMPLOYMENT	1,556,122	86.43	1,573,169		-1.08	
**	# RECS WITH VALID UI ADDRESS BLOCK	101,320	86.30	99,758		1.56	
**	MONTH 3 EMPLOYMENT	1,263,960	70.20	1,256,681		0.57	
**	# RECS WITH VALID MAILING/OTHER BLOCK	19,627	16.71	19,357		1.39	
**	MONTH 3 EMPLOYMENT	471,645	26.19	465,682		1.28	
** COUNTS AND PERCENTAGES EXCLUDE MASTER RECS: MEEI=2							
*** COUNTS AND PERCENTAGES INCLUDE MASTER RECORDS ONLY							
OTHER COUNTS AND PERCENTAGES INCLUDE ALL ACTIVE CURRENT QUARTER RECORDS							

EXHIBIT 13F (continued)

DATE: MM/DD/YYYY TIME: 06:06:06 PM		(STATE)		PAGE 16	
INITIAL RUN YYYY/Q		EQUI DATA COUNTS - TABLE 3			
BUREAU OF LABOR STATISTICS - EQUI PROCESSING					
		CURRENT	% OF CURR	PREV.QTR	% CHG
		QTR TOT	TOTAL RECS	TOTAL	

PHYSICAL LOCATION ADDRESS:					

**	STREET ADDRESS LINE 1	81,053	69.83	81,324	-0.33
**	MONTH 3 EMPLOYMENT	1,559,120	86.60	1,576,429	-1.09
**	STREET ADDRESS LINE 2	5,385	4.63	5,037	6.90
**	MONTH 3 EMPLOYMENT	88,174	4.89	88,279	-0.11
**	CITY	80,826	69.63	81,082	-0.31
**	MONTH 3 EMPLOYMENT	1,557,779	86.52	1,574,870	-1.08
**	STATE ABBREVIATION	80,787	69.60	81,043	-0.31
**	MONTH 3 EMPLOYMENT	1,557,628	86.51	1,574,728	-1.08
**	ZIP CODE (NUMERIC AND > 0)	80,955	69.74	81,216	-0.32
**	MONTH 3 EMPLOYMENT	1,558,302	86.55	1,575,533	-1.09
**	ZIP CODE EXPANSION (NUMERIC AND > 0)	2,059	1.77	1,854	11.05
**	MONTH 3 EMPLOYMENT	65,736	3.65	65,100	0.97
**	# RECS WITH PL STATE ABBREVIATION "ZZ" (OUT OF COUNTRY)	0	0.00	0	
**	MONTH 3 EMPLOYMENT	0	0.00	0	0.00
**	# RECS WITH PL STATE ABBREVIATION "CN" (CANADA)	0	0.00	0	
**	MONTH 3 EMPLOYMENT	0	0.00	0	0.00
**	# RECS WITH PL STATE ABBREV "AE","AA" OR "AP" (MILITARY P.O.)	0	0.00	0	
**	MONTH 3 EMPLOYMENT	0	0.00	0	0.00
UI ADDRESS:					

	STREET ADDRESS LINE 1	101,352	86.32	99,793	1.56
	MONTH 3 EMPLOYMENT	1,263,549	70.18	1,256,293	0.57
	STREET ADDRESS LINE 2	9	0.00	9	0.00
	MONTH 3 EMPLOYMENT	325	0.01	352	-7.67
	CITY	101,329	86.31	99,767	1.56
	MONTH 3 EMPLOYMENT	1,264,304	70.22	1,257,020	0.57
	STATE ABBREVIATION	101,296	86.28	99,734	1.56
	MONTH 3 EMPLOYMENT	1,263,935	70.20	1,256,655	0.57
	ZIP CODE (NUMERIC AND > 0)	101,296	86.28	99,734	1.56
	MONTH 3 EMPLOYMENT	1,263,935	70.20	1,256,655	0.57
	ZIP CODE EXPANSION (NUMERIC AND > 0)	6	0.00	6	0.00
	MONTH 3 EMPLOYMENT	164	0.00	166	-1.20

** COUNTS AND PERCENTAGES EXCLUDE MASTER RECORDS (MEE= 2)					
OTHER COUNTS AND PERCENTAGES INCLUDE ALL ACTIVE CUEENT QUARTER RECORDS					

EXHIBIT 13F (continued)

DATE: MM/DD/YYYY TIME: 06:06:06 PM
 INITIAL RUN YYYY/Q

(STATE)
 EQUI DATA COUNTS - TABLE 3
 BUREAU OF LABOR STATISTICS - EQUI PROCESSING

PAGE 17

	CURRENT QTR TOT	% OF CURR TOTAL RECS	PREV.QTR TOTAL	% CHG
MAILING/OTHER ADDRESS:				
STREET ADDRESS LINE 1	19,664	16.74	19,396	1.38
MONTH 3 EMPLOYMENT	472,324	26.23	466,374	1.27
STREET ADDRESS LINE 2	1,974	1.68	1,842	7.16
MONTH 3 EMPLOYMENT	30,231	1.67	27,874	8.45
CITY	19,640	16.72	19,369	1.39
MONTH 3 EMPLOYMENT	471,995	26.21	466,045	1.27
STATE ABBREVIATION	19,617	16.70	19,347	1.39
MONTH 3 EMPLOYMENT	471,637	26.19	465,673	1.28
ZIP CODE (NUMERIC AND > 0)	19,628	16.71	19,359	1.38
MONTH 3 EMPLOYMENT	471,898	26.21	465,987	1.26
ZIP CODE EXPANSION (NUMERIC AND > 0)	3,511	2.99	3,333	5.34
MONTH 3 EMPLOYMENT	95,931	5.32	92,502	3.70

ADDRESS TYPE:

UI ADDRESS TYPE:

1 - PHYSICAL LOCATION	0	0.00	0	
2 - MAILING ADDRESS	0	0.00	0	
3 - CORPORATE HQ OR CENTRAL OFFICE	0	0.00	0	
9 - UNKNOWN	113,818	96.94	112,487	1.18

MAILING/OTHER ADDRESS TYPE:

1 - PHYSICAL LOCATION	3,357	2.85	3,202	4.84
2 - MAILING ADDRESS	18	0.01	17	5.88
3 - CORPORATE HQ OR CENTRAL OFFICE	1	0.00	1	0.00
9 - UI TAX ADDRESS OR UNKNOWN	14,699	12.52	14,586	0.77
# RECS WITH PL ADDRESS IDENTICAL TO UI OR M/O ADDRESS	20,371	17.35	20,557	-0.90

REPORTING UNIT DESCRIPTION

# RECS WITH REPORTING UNIT DESCRIPTION NOT ALL BLANKS	14,004	11.92	13,947	0.40
***** # RECS WITH RUD AND MEEI 1	113	0.11	114	-0.87
***** # RECS WITH RUD AND MEEI 2	35	2.62	35	0.00
***** # RECS WITH RUD AND MEEI 4 OR 6	1	0.75	1	0.00
***** # RECS WITH RUD AND MEEI 3 OR 5	13,855	80.90	13,797	0.42
***** # RECS WITH MEEI 3 OR 5 WITH BLANK RUD & A BLANK PL ADDRESS	192	1.12	188	2.12
# RECS WITH RUD ZEROES (WILL BE SET TO BLANK)	0	0.00	0	

***** PERCENTAGES ARE BASED ON TOTAL FOR RESPECTIVE MEEI CODE
 OTHER COUNTS AND PERCENTAGES INCLUDE ALL ACTIVE CURRENT QUARTER RECORDS

EXHIBIT 13F (continued)

DATE: MM/DD/YYYY TIME: 06:06:06 PM		(STATE)		PAGE 18	
INITIAL RUN YYYY/Q		EQUI DATA COUNTS - TABLE 3			
BUREAU OF LABOR STATISTICS - EQUI PROCESSING					
		CURRENT	% OF CURR	PREV. QTR	
		QTR TOT	TOTAL RECS	TOTAL	% CHG

SECTION 5 - SUMMARY COUNTS OF CONTINUING UNITS					
****	# TOTAL CONTINUOUS UNIT RECORDS	112,998	96.24	112,614	0.34
****	MONTH 3 EMPLOYMENT	1,762,725	97.91	1,786,970	-1.35
MEEI CHANGES					

	# RECORDS CHANGING MEEI CODE FROM PREV QTR	41	0.03	19	115.78
	MONTH 3 EMPLOYMENT	16,353	0.92	6,908	136.72
	# RECORDS CHANGING FROM MEEI 1, 4 OR 6 TO 2	15	0.01	7	114.28
	MONTH 3 EMPLOYMENT	2,278	0.12	1,864	22.21
	# RECORDS CHANGING FROM MEEI 2 TO 1, 4 OR 6	17	0.01	8	112.50
	MONTH 3 EMPLOYMENT	12,761	0.72	782	1531.84
	# RECORDS CHANGING FROM MEEI 3 TO 5	0	0.00	0	
	MONTH 3 EMPLOYMENT	0	0.00	0	
	# RECORDS CHANGING FROM MEEI 5 TO 3	0	0.00	0	
	MONTH 3 EMPLOYMENT	0	0.00	0	
	# MASTER RECORDS WITH REPORTING CHANGE INDICATOR = 1	0	0.00	0	
	MONTH 3 EMPLOYMENT	0	0.00	0	
	# NON-MASTER RECORDS WITH REPORTING CHANGE INDICATOR = 1	0	0.00	0	
	MONTH 3 EMPLOYMENT	0	0.00	0	
NAICS					

**	# RECS CHGD BTWN VALID NAICS CODES (EXCL 999999)	2,035	1.82	2	1650.00
**	# RECS CHGD FROM NAICS 999999 TO A VALID NAICS	54	0.04	4	1250.00
**	# RECS CHGD BTWN VALID NAICS TO NAICS 999999	0	0.00	2	-100.00
**	# RECS WITH NAICS 999999 FOR CURRENT & PREV QTS	2,304	2.06	3,167	-27.24
**	# RECS WITH NAICS 999999 FOR CUR & PREV QTR, EMPL > 25	3	0.00	2	50.00
SIC					

**	# RECS CHGD FROM VALID SIC TO ANOTHER VALID SIC (EXCL 9999)	0	0.00	0	
**	# RECS CHGD FROM SIC 9999 TO A VALID SIC	0	0.00	0	
**	# RECS CHGD FROM VALID SIC TO SIC 9999	97	0.08	4	2325.00
**	# RECS WITH SIC 9999 FOR CURRENT & PREV QTR	28,321	25.35	26,355	7.45
**	# RECS WITH SIC 9999 FOR CURRENT & PREV QTR, EMPL > 25	1,101	0.98	1,058	4.06

OTHER PERCENTAGES IN SECTION 5 BASED ON CONTINUOUS RECORDS					
** COUNTS AND PERCENTAGES EXCLUDE MASTER RECORDS (MEEI = 2)					
**** PERCENTAGES BASED ON ALL ACTIVE CURRENT QUARTER RECORDS					

EXHIBIT 13F (continued)

DATE: MM/DD/YYYY TIME: 06:06:06 PM		(STATE)		PAGE		19	
INITIAL RUN YYYY/Q		EQUI DATA COUNTS - TABLE 3					
BUREAU OF LABOR STATISTICS - EQUI PROCESSING							
		CURRENT	% OF CURR	PREV.QTR			
		QTR TOT	TOTAL RECS	TOTAL		% CHG	

COUNTY CODE							

**	# RECS CHGD FROM VALID COUNTY TO ANOTHER VALID COUNTY	822	0.73	51	1511.76		
**	# RECS CHGD FROM A VALID CODE TO 999	22	0.01	34	-35.29		
**	# RECS CHGD FROM 999 TO A VALID CODE	74	0.06	7	957.14		
**	# RECS CHGD FROM VALID COUNTY TO 995, 996 OR 998	22	0.01	0			
**	# RECS CHGD FROM 995, 996 OR 998 TO VALID COUNTY	3	0.00	0			
**	# RECS WITH COUNTY 999 FOR CURRENT & PREV QTR	9,550	8.55	9,165	4.20		
**	# RECS WITH COUNTY 999 FOR CURRENT & PREV QTR, EMP > 25	308	0.27	306	0.65		
AUXILIARY CODE							

**	# RECS CHGD FROM AUXILIARY CODE 0 TO AUX CODE 5	0	0.00	0			
**	# RECS CHGD FROM AUX CODE 0 TO VALID AUX CODE 8	0	0.00	0			
**	# RECS CHGD FROM AUX CODE 5 TO AUX CODE 0	1	0.00	0			
**	# RECS CHGD FROM AUX CODE 5 TO VALID AUX CODE 8	32	0.02	0			
**	# RECS CHGD FROM AUX CODE 8 TO AUX CODE 0	0	0.00	0			
**	# RECS CHGD FROM AUX CODE 8 TO AUX CODE 5	3	0.00	0			
CODE CHANGES (INCLUDING ECONOMIC CODE CHANGES)							

**	# RECS WITH NAICS CHANGE ONLY (FROM PREVIOUS QUARTER)	1,906	1.70	6	1666.66		
**	MONTH 3 EMPLOYMENT	38,349	2.17	38	818.42		
**	# RECS WITH LOCATION CHANGE ONLY	785	0.70	107	633.64		
**	MONTH 3 EMPLOYMENT	19,754	1.12	504	3819.44		
**	# RECS WITH OWNERSHIP CHANGE ONLY	0	0.00	0			
**	MONTH 3 EMPLOYMENT	0	0.00	0			
**	# RECS WITH NAICS & LOCATION CHANGE	181	0.16	2	8950.00		
**	MONTH 3 EMPLOYMENT	3,044	0.17	144	2013.88		
**	# RECS WITH NAICS & OWNERSHIP CHANGE	1	0.00	0			
**	MONTH 3 EMPLOYMENT	24	0.00	0			
**	# RECS WITH LOCATION & OWNERSHIP CHANGE	0	0.00	0			
**	MONTH 3 EMPLOYMENT	0	0.00	0			
**	# RECS WITH NAICS, LOCATION & OWNERSHIP CHANGE	1	0.00	0			
**	MONTH 3 EMPLOYMENT	33	0.00	0			

** COUNTS AND PERCENTAGES EXCLUDE MASTER RECORDS (MEEI = 2)							
OTHER PERCENTAGES IN SECTION 5 BASED ON CONTINUOUS RECORDS							

EXHIBIT 13F (continued)

DATE: MM/DD/YYYY TIME: 06:06:06 PM		(STATE)			PAGE	20
INITIAL RUN YYYY/Q		EQUI DATA COUNTS - TABLE 3				
BUREAU OF LABOR STATISTICS - EQUI PROCESSING						
		CURRENT	% OF CURR	PREV.QTR		
		QTR TOT	TOTAL RECS	TOTAL	% CHG	
SECTION 6 - SUMMARY OF PRIVATE CONTINUOUS RECORDS BY SIZE CLASS, EXCLUDING MASTERS						
ALL PRIVATE CONTINUOUS RECORDS						

* #	RECORDS WITH MONTH 3 EMPL 1000 OR MORE	63	0.05	67	-5.97	
* #	MONTH 3 EMPLOYMENT	116,631	8.09	117,970	-1.13	
* #	RECORDS WITH MONTH 3 EMPL 500-999	141	0.13	145	-2.75	
* #	MONTH 3 EMPLOYMENT	94,085	6.53	97,441	-3.44	
* #	RECORDS WITH MONTH 3 EMPL 250-499	459	0.42	471	-2.54	
* #	MONTH 3 EMPLOYMENT	160,011	11.10	163,304	-2.01	
* #	RECORDS WITH MONTH 3 EMPL 100-249	1,520	1.40	1,580	-3.79	
* #	MONTH 3 EMPLOYMENT	228,272	15.84	237,133	-3.73	
* #	RECORDS WITH MONTH 3 EMPL 50-99	2,910	2.68	2,896	0.48	
* #	MONTH 3 EMPLOYMENT	198,816	13.80	197,859	0.48	
* #	RECORDS WITH MONTH 3 EMPL 20-49	8,379	7.72	8,599	-2.55	
* #	MONTH 3 EMPLOYMENT	252,794	17.54	261,079	-3.17	
* #	RECORDS WITH MONTH 3 EMPL 10-19	12,250	11.30	12,477	-1.81	
* #	MONTH 3 EMPLOYMENT	165,529	11.49	168,203	-1.58	
* #	RECORDS WITH MONTH 3 EMPL 5-9	19,172	17.68	19,323	-0.78	
* #	MONTH 3 EMPLOYMENT	126,960	8.81	127,807	-0.66	
* #	RECORDS WITH MONTH 3 EMPL 1-4	48,319	44.57	48,913	-1.21	
* #	MONTH 3 EMPLOYMENT	97,408	6.76	98,685	-1.29	
* #	RECORDS WITH MONTH 3 EMPL 0	15,193	14.01	13,565	12.00	
* #	MONTH 3 EMPLOYMENT	0	0.00	0	0.00	
** #	TOTAL PRIVATE CONTINUOUS RECORDS	108,406	96.11	108,036	0.34	
** #	MONTH 3 EMPLOYMENT	1,440,506	97.47	1,469,481	-1.97	
ALL PRIVATE CONTINUOUS SUBUNIT						

#	RECORDS WITH MONTH 3 EMPL 1000 OR MORE	27	42.85	31	-12.90	
#	MONTH 3 EMPLOYMENT	42,967	36.84	50,911	-15.60	
#	RECORDS WITH MONTH 3 EMPL 500-999	53	37.58	56	-5.35	
#	MONTH 3 EMPLOYMENT	36,315	38.59	38,382	-5.38	
#	RECORDS WITH MONTH 3 EMPL 250-499	154	33.55	155	-0.64	
#	MONTH 3 EMPLOYMENT	55,243	34.52	55,750	-0.90	
#	RECORDS WITH MONTH 3 EMPL 100-249	503	33.09	552	-8.87	
#	MONTH 3 EMPLOYMENT	74,060	32.44	82,024	-9.70	
#	RECORDS WITH MONTH 3 EMPL 50-99	1,005	34.53	995	1.00	
#	MONTH 3 EMPLOYMENT	68,718	34.56	68,089	0.92	

* PERCENTAGES BASED ON TOTAL PRIVATE CONTINUOUS RECORDS AND EMPLOYMENT						
** PERCENTAGES BASED ON TOTAL PRIVATE RECORDS AND EMPLOYMENT						
OTHER PERCENTAGES BASED ON RESPECTIVE SIZE CLASS FOR ALL PRIVATE CONTINUOUS RECORDS AND EMPLOYMENT						

EXHIBIT 13F (continued)

DATE: MM/DD/YYYY TIME: 06:06:06 PM		(STATE)		PAGE	21
INITIAL RUN YYYY/Q		EQUI DATA COUNTS - TABLE 3			
BUREAU OF LABOR STATISTICS - EQUI PROCESSING					
		CURRENT	% OF CURR	PREV.QTR	
		QTR TOT	TOTAL RECS	TOTAL	% CHG
#	RECORDS WITH MONTH 3 EMPL 20-49	2,278	27.18	2,420	-5.86
	MONTH 3 EMPLOYMENT	68,738	27.19	73,942	-7.03
#	RECORDS WITH MONTH 3 EMPL 10-19	2,724	22.23	2,778	-1.94
	MONTH 3 EMPLOYMENT	37,374	22.57	37,878	-1.33
#	RECORDS WITH MONTH 3 EMPL 5-9	3,731	19.46	3,632	2.72
	MONTH 3 EMPLOYMENT	25,055	19.73	24,446	2.49
#	RECORDS WITH MONTH 3 EMPL 1-4	2,827	5.85	2,774	1.91
	MONTH 3 EMPLOYMENT	7,723	7.92	7,577	1.92
#	RECORDS WITH MONTH 3 EMPL 0	829	5.45	806	2.85
	MONTH 3 EMPLOYMENT	0	0.00	0	0.00
* #	TOTAL PRIVATE CONTINUOUS RECORDS	14,131	13.03	14,199	-0.47
* #	MONTH 3 EMPLOYMENT	416,193	28.89	438,999	-5.19
NAICS 999999					
#	RECORDS WITH MONTH 3 EMPL 1000 OR MORE	0	0.00	0	0.00
	MONTH 3 EMPLOYMENT	0	0.00	0	0.00
#	RECORDS WITH MONTH 3 EMPL 500-999	0	0.00	0	0.00
	MONTH 3 EMPLOYMENT	0	0.00	0	0.00
#	RECORDS WITH MONTH 3 EMPL 250-499	0	0.00	0	0.00
	MONTH 3 EMPLOYMENT	0	0.00	0	0.00
#	RECORDS WITH MONTH 3 EMPL 100-249	0	0.00	0	0.00
	MONTH 3 EMPLOYMENT	0	0.00	0	0.00
#	RECORDS WITH MONTH 3 EMPL 50-99	1	0.03	2	-50.00
	MONTH 3 EMPLOYMENT	64	0.03	117	-45.29
#	RECORDS WITH MONTH 3 EMPL 20-49	21	0.25	33	-36.36
	MONTH 3 EMPLOYMENT	508	0.20	850	-40.23
#	RECORDS WITH MONTH 3 EMPL 10-19	81	0.66	134	-39.55
	MONTH 3 EMPLOYMENT	1,029	0.62	1,725	-40.34
#	RECORDS WITH MONTH 3 EMPL 5-9	203	1.05	300	-32.33
	MONTH 3 EMPLOYMENT	1,330	1.04	1,931	-31.12
#	RECORDS WITH MONTH 3 EMPL 1-4	1,225	2.53	1,909	-35.83
	MONTH 3 EMPLOYMENT	2,034	2.08	3,191	-36.25
#	RECORDS WITH MONTH 3 EMPL 0	773	5.08	791	-2.27
	MONTH 3 EMPLOYMENT	0	0.00	0	0.00
* #	TOTAL PRIVATE CONTINUOUS RECORDS	2,304	2.12	3,169	-27.29
* #	MONTH 3 EMPLOYMENT	4,965	0.34	7,814	-36.46
* PERCENTAGES BASED ON TOTAL PRIVATE CONTINUOUS RECORDS AND EMPLOYMENT					
OTHER PERCENTAGES BASED ON RESPECTIVE SIZE CLASS FOR ALL PRIVATE CONTINUOUS RECORDS AND EMPLOYMENT					

EXHIBIT 13F (continued)

	CURRENT	% OF CURR	PREV.QTR	
	QTR TOT	TOTAL RECS	TOTAL	% CHG
SIC 9999				

# RECORDS WITH MONTH 3 EMPL 1000 OR MORE	9	14.28	9	0.00
MONTH 3 EMPLOYMENT	14,381	12.33	12,833	12.06
# RECORDS WITH MONTH 3 EMPL 500-999	13	9.21	13	0.00
MONTH 3 EMPLOYMENT	8,132	8.64	8,402	-3.21
# RECORDS WITH MONTH 3 EMPL 250-499	37	8.06	32	15.62
MONTH 3 EMPLOYMENT	12,838	8.02	10,795	18.92
# RECORDS WITH MONTH 3 EMPL 100-249	155	10.19	144	7.63
MONTH 3 EMPLOYMENT	23,154	10.14	21,314	8.63
# RECORDS WITH MONTH 3 EMPL 50-99	313	10.75	327	-4.28
MONTH 3 EMPLOYMENT	21,067	10.59	22,537	-6.52
# RECORDS WITH MONTH 3 EMPL 20-49	1,165	13.90	1,081	7.77
MONTH 3 EMPLOYMENT	35,015	13.85	32,179	8.81
# RECORDS WITH MONTH 3 EMPL 10-19	1,932	15.77	1,862	3.75
MONTH 3 EMPLOYMENT	25,993	15.70	24,759	4.98
# RECORDS WITH MONTH 3 EMPL 5-9	3,955	20.62	3,699	6.92
MONTH 3 EMPLOYMENT	26,059	20.52	24,251	7.45
# RECORDS WITH MONTH 3 EMPL 1-4	15,413	31.89	14,699	4.85
MONTH 3 EMPLOYMENT	27,891	28.63	26,658	4.62
# RECORDS WITH MONTH 3 EMPL 0	5,234	34.45	4,316	21.26
MONTH 3 EMPLOYMENT	0	0.00	0	0.00
* # TOTAL RECS WITH SIC 9999	28,226	26.03	26,182	7.80
* MONTH 3 EMPLOYMENT	194,530	13.50	183,728	5.87

COUNTY 999				

# RECORDS WITH MONTH 3 EMPL 1000 OR MORE	1	1.58	1	0.00
MONTH 3 EMPLOYMENT	1,476	1.26	1,546	-4.52
# RECORDS WITH MONTH 3 EMPL 500-999	1	0.70	2	-50.00
MONTH 3 EMPLOYMENT	510	0.54	1,336	-61.82
# RECORDS WITH MONTH 3 EMPL 250-499	11	2.39	9	22.22
MONTH 3 EMPLOYMENT	3,824	2.38	3,347	14.25
# RECORDS WITH MONTH 3 EMPL 100-249	42	2.76	47	-10.63
MONTH 3 EMPLOYMENT	6,175	2.70	6,774	-8.84
# RECORDS WITH MONTH 3 EMPL 50-99	97	3.33	100	-3.00
MONTH 3 EMPLOYMENT	6,596	3.31	6,768	-2.54

 * PERCENTAGES BASED ON TOTAL PRIVATE CONTINUOUS RECORDS AND EMPLOYMENT
 OTHER PERCENTAGES BASED ON RESPECTIVE SIZE CLASS FOR ALL PRIVATE CONTINUOUS RECORDS AND EMPLOYMENT

EXHIBIT 13F (continued)

DATE: MM/DD/YYYY TIME: 06:06:06 PM		(STATE)		PAGE 23	
INITIAL RUN YYYY/Q		EQUI DATA COUNTS - TABLE 3			
BUREAU OF LABOR STATISTICS - EQUI PROCESSING					
		CURRENT	% OF CURR	PREV.QTR	
		QTR TOT	TOTAL RECS	TOTAL	% CHG

# RECORDS WITH MONTH 3 EMPL 20-49		333	3.97	334	-0.29
MONTH 3 EMPLOYMENT		9,959	3.93	10,004	-0.44
# RECORDS WITH MONTH 3 EMPL 10-19		489	3.99	453	7.94
MONTH 3 EMPLOYMENT		6,665	4.02	6,136	8.62
# RECORDS WITH MONTH 3 EMPL 5-9		731	3.81	676	8.13
MONTH 3 EMPLOYMENT		4,772	3.75	4,455	7.11
# RECORDS WITH MONTH 3 EMPL 1-4		5,013	10.37	4,976	0.74
MONTH 3 EMPLOYMENT		7,770	7.97	7,726	0.56
# RECORDS WITH MONTH 3 EMPL 0		2,851	18.76	2,612	9.15
MONTH 3 EMPLOYMENT		0	0.00	0	0.00
* # TOTAL RECS WITH COUNTY 999		9,569	8.82	9,210	3.89
* MONTH 3 EMPLOYMENT		47,747	3.31	48,092	-0.71
ZERO-FILLED EIN					

# RECORDS WITH MONTH 3 EMPL 1000 OR MORE		0	0.00	0	0.00
MONTH 3 EMPLOYMENT		0	0.00	0	0.00
# RECORDS WITH MONTH 3 EMPL 500-999		0	0.00	0	0.00
MONTH 3 EMPLOYMENT		0	0.00	0	0.00
# RECORDS WITH MONTH 3 EMPL 250-499		0	0.00	0	0.00
MONTH 3 EMPLOYMENT		0	0.00	0	0.00
# RECORDS WITH MONTH 3 EMPL 100-249		0	0.00	1	-100.00
MONTH 3 EMPLOYMENT		0	0.00	102	-100.00
# RECORDS WITH MONTH 3 EMPL 50-99		1	0.03	2	-50.00
MONTH 3 EMPLOYMENT		86	0.04	143	-39.86
# RECORDS WITH MONTH 3 EMPL 20-49		3	0.03	5	-40.00
MONTH 3 EMPLOYMENT		69	0.02	142	-51.40
# RECORDS WITH MONTH 3 EMPL 10-19		10	0.08	16	-37.50
MONTH 3 EMPLOYMENT		138	0.08	235	-41.27
# RECORDS WITH MONTH 3 EMPL 5-9		52	0.27	45	15.55
MONTH 3 EMPLOYMENT		323	0.25	297	8.75
# RECORDS WITH MONTH 3 EMPL 1-4		185	0.38	202	-8.41
MONTH 3 EMPLOYMENT		335	0.34	365	-8.21
# RECORDS WITH MONTH 3 EMPL 0		243	1.59	228	6.57
MONTH 3 EMPLOYMENT		0	0.00	0	0.00
* # TOTAL RECS WITH ZERO-FILLED EIN		494	0.45	499	-1.00
* MONTH 3 EMPLOYMENT		951	0.06	1,284	-25.93

* PERCENTAGES BASED ON TOTAL PRIVATE CONTINUOUS RECORDS AND EMPLOYMENT					
OTHER PERCENTAGES BASED ON RESPECTIVE SIZE CLASS FOR ALL PRIVATE CONTINUOUS RECORDS AND EMPLOYMENT					

EXHIBIT 13F (continued)

DATE: MM/DD/YYYY TIME: 06:06:06 PM		(STATE)		PAGE	24
INITIAL RUN YYYY/Q		EQUI DATA COUNTS - TABLE 3			
BUREAU OF LABOR STATISTICS - EQUI PROCESSING					
		CURRENT	% OF CURR	PREV.QTR	
		QTR TOT	TOTAL RECS	TOTAL	% CHG

VALID PHYSICAL LOCATION ADDRESS					

#	RECORDS WITH MONTH 3 EMPL 1000 OR MORE	61	96.82	65	-6.15
	MONTH 3 EMPLOYMENT	113,806	97.57	115,258	-1.25
#	RECORDS WITH MONTH 3 EMPL 500-999	139	98.58	141	-1.41
	MONTH 3 EMPLOYMENT	92,955	98.79	95,080	-2.23
#	RECORDS WITH MONTH 3 EMPL 250-499	438	95.42	453	-3.31
	MONTH 3 EMPLOYMENT	152,272	95.16	156,763	-2.86
#	RECORDS WITH MONTH 3 EMPL 100-249	1,431	94.14	1,493	-4.15
	MONTH 3 EMPLOYMENT	215,689	94.48	224,582	-3.95
#	RECORDS WITH MONTH 3 EMPL 50-99	2,577	88.55	2,559	0.70
	MONTH 3 EMPLOYMENT	176,894	88.97	175,095	1.02
#	RECORDS WITH MONTH 3 EMPL 20-49	7,194	85.85	7,381	-2.53
	MONTH 3 EMPLOYMENT	217,071	85.86	224,801	-3.43
#	RECORDS WITH MONTH 3 EMPL 10-19	10,142	82.79	10,386	-2.34
	MONTH 3 EMPLOYMENT	137,279	82.93	140,422	-2.23
#	RECORDS WITH MONTH 3 EMPL 5-9	15,332	79.97	15,469	-0.88
	MONTH 3 EMPLOYMENT	101,791	80.17	102,574	-0.76
#	RECORDS WITH MONTH 3 EMPL 1-4	32,581	67.42	33,112	-1.60
	MONTH 3 EMPLOYMENT	69,016	70.85	70,263	-1.77
#	RECORDS WITH MONTH 3 EMPL 0	8,238	54.22	7,354	12.02
	MONTH 3 EMPLOYMENT	0	0.00	0	0.00
*	# TOTAL RECS WITH A VALID PL ADDRESS	78,133	72.07	78,413	-0.35
*	MONTH 3 EMPLOYMENT	1,276,773	88.63	1,304,838	-2.15
SUBUNITS (MEEI 3 OR 5) WITH REPORTING UNIT DESCRIPTIONS					

***	# RECORDS WITH MONTH 3 EMPL 1000 OR MORE	19	70.37	21	-9.52
***	MONTH 3 EMPLOYMENT	31,437	73.16	35,381	-11.14
***	# RECORDS WITH MONTH 3 EMPL 500-999	40	75.47	45	-11.11
***	MONTH 3 EMPLOYMENT	27,940	76.93	30,924	-9.64
***	# RECORDS WITH MONTH 3 EMPL 250-499	116	75.32	117	-0.85
***	MONTH 3 EMPLOYMENT	42,916	77.68	43,496	-1.33
***	# RECORDS WITH MONTH 3 EMPL 100-249	379	75.34	426	-11.03
***	MONTH 3 EMPLOYMENT	55,365	74.75	63,329	-12.57
***	# RECORDS WITH MONTH 3 EMPL 50-99	785	78.10	796	-1.38
***	MONTH 3 EMPLOYMENT	53,880	78.40	54,662	-1.43

* PERCENTAGES BASED ON TOTAL PRIVATE CONTINUOUS RECORDS AND EMPLOYMENT					
*** PERCENTAGES BASED ON RESPECTIVE SIZE CLASS FOR PRIVATE CONTINUOUS SUBUNITS AND EMPLOYMENT					
OTHER PERCENTAGES BASED ON RESPECTIVE SIZE CLASS FOR ALL PRIVATE CONTINUOUS RECORDS AND EMPLOYMENT					

EXHIBIT 13F (continued)

DATE: MM/DD/YYYY TIME: 06:06:06 PM		(STATE)		PAGE 25	
INITIAL RUN YYYY/Q		EQUI DATA COUNTS - TABLE 3			
BUREAU OF LABOR STATISTICS - EQUI PROCESSING					
		CURRENT	% OF CURR	PREV.QTR	
		QTR TOT	TOTAL RECS	TOTAL	% CHG

***	# RECORDS WITH MONTH 3 EMPL 20-49	1,732	76.03	1,854	-6.58
***	MONTH 3 EMPLOYMENT	52,362	76.17	56,430	-7.20
***	# RECORDS WITH MONTH 3 EMPL 10-19	2,161	79.33	2,223	-2.78
***	MONTH 3 EMPLOYMENT	29,612	79.23	30,137	-1.74
***	# RECORDS WITH MONTH 3 EMPL 5-9	3,034	81.31	2,960	2.50
***	MONTH 3 EMPLOYMENT	20,382	81.34	19,909	2.37
***	# RECORDS WITH MONTH 3 EMPL 1-4	2,298	81.28	2,220	3.51
***	MONTH 3 EMPLOYMENT	6,280	81.31	6,049	3.81
***	# RECORDS WITH MONTH 3 EMPL 0	707	85.28	679	4.12
***	MONTH 3 EMPLOYMENT	0	0.00	0	0.00
****	# TOTAL SUBUNITS WITH RU DESCRIPTIONS	11,271	79.76	11,341	-0.61
****	MONTH 3 EMPLOYMENT	320,174	76.92	340,317	-5.91
SUBUNITS (MEEI 3 OR 5) WITH NO RUD NOR VALID PL ADDRESS					

***	# RECORDS WITH MONTH 3 EMPL 1000 OR MORE	0	0.00	0	0.00
***	MONTH 3 EMPLOYMENT	0	0.00	0	0.00
***	# RECORDS WITH MONTH 3 EMPL 500-999	0	0.00	0	0.00
***	MONTH 3 EMPLOYMENT	0	0.00	0	0.00
***	# RECORDS WITH MONTH 3 EMPL 250-499	2	1.29	1	100.00
***	MONTH 3 EMPLOYMENT	726	1.31	386	88.08
***	# RECORDS WITH MONTH 3 EMPL 100-249	2	0.39	5	-60.00
***	MONTH 3 EMPLOYMENT	338	0.45	721	-53.12
***	# RECORDS WITH MONTH 3 EMPL 50-99	14	1.39	10	40.00
***	MONTH 3 EMPLOYMENT	955	1.38	718	33.00
***	# RECORDS WITH MONTH 3 EMPL 20-49	12	0.52	14	-14.28
***	MONTH 3 EMPLOYMENT	355	0.51	467	-23.98
***	# RECORDS WITH MONTH 3 EMPL 10-19	8	0.29	14	-42.85
***	MONTH 3 EMPLOYMENT	106	0.28	195	-45.64
***	# RECORDS WITH MONTH 3 EMPL 5-9	32	0.85	27	18.51
***	MONTH 3 EMPLOYMENT	209	0.83	170	22.94
***	# RECORDS WITH MONTH 3 EMPL 1-4	26	0.91	26	0.00
***	MONTH 3 EMPLOYMENT	56	0.72	64	-12.50
***	# RECORDS WITH MONTH 3 EMPL 0	23	2.77	23	0.00
***	MONTH 3 EMPLOYMENT	0	0.00	0	0.00
****	# TOTAL SUBUNITS WITH NO RUD NOR VALID PL ADDRESS	119	0.84	120	-0.83
****	MONTH 3 EMPLOYMENT	2,745	0.65	2,721	0.88

*** PERCENTAGES BASED ON RESPECTIVE SIZE CLASS FOR PRIVATE CONTINUOUS SUBUNITS AND EMPLOYMENT					
**** PERCENTAGES BASED ON TOTAL PRIVATE CONTINUOUS SUBUNITS AND EMPLOYMENT					

EXHIBIT 13F (continued)

DATE: MM/DD/YYYY TIME: 06:06:06 PM		(STATE)		PAGE 26	
INITIAL RUN YYYY/Q		EQUI DATA COUNTS - TABLE 3			
BUREAU OF LABOR STATISTICS - EQUI PROCESSING					
		CURRENT	% OF CURR	PREV. QTR	
		QTR TOT	TOTAL RECS	TOTAL	% CHG

SECTION 7 - SUMMARY COUNTS OF NEW UNITS (NEW UI/RUNS)					
****	# TOTAL NEW RECORDS	4,403	3.75	3,120	41.12
****	MONTH 3 EMPLOYMENT	37,602	2.08	24,063	56.26
MULTI-ESTABLISHMENT EMPLOYER INDICATOR					

	1 - NEW SINGLE UNITS	3,924	89.12	2,801	40.09
	2 - NEW MULTI-UNIT MASTER RECORDS	16	0.36	4	300.00
	3 - NEW SUB-UNIT RECORDS	461	10.47	312	47.75
	4 - NEW MULTI-ESTAB EMPLOYER REPORTING AS A SINGLE UNIT	1	0.02	2	-50.00
	5 - NEW SUB-UNIT REPRESENTING A COMBINATION OF ESTABL	0	0.00	0	
	6 - NEW MULTIS REPORTING AS SINGLE UNIT (BELOW EMPL LEVEL)	1	0.02	1	0.00
NAICS					

**	# NEW RECS WITH VALID NAICS (EXCLUDING 999999)	2,955	67.35	2,222	32.98
**	MONTH 3 EMPLOYMENT	33,229	88.37	21,674	53.31
**	# NEW RECS WITH NAICS 999999	1,432	32.64	894	60.17
SIC					

**	# NEW RECS WITH VALID SICS (EXCLUDING 9999)	307	6.99	299	2.67
**	MONTH 3 EMPLOYMENT	6,137	16.32	8,083	-24.07
**	# NEW RECS WITH SIC 9999	4,080	93.00	2,817	44.83
COUNTY CODE					

**	# NEW RECS WITH VALID COUNTY CODES (EXCL 995 - 999)	3,611	82.31	2,297	57.20
**	# NEW RECS WITH COUNTY CODE 995, 996 OR 998	15	0.34	15	0.00
**	# NEW RECS WITH COUNTY CODE 999	761	17.34	804	-5.34
EI ACCOUNT NUMBER					

	# NEW RECS WITH USABLE EIN	4,325	98.22	3,068	40.97
*	# NEW PRIVATE RECS WITH USABLE EIN	4,322	0.00	3,040	42.17
*	# NEW PRIVATE RECS WITH UNKNOWN EIN	78	0.00	52	50.00
*	# NEW PRIVATE RECS WITH UNUSABLE EIN	0	0.00	0	

* PERCENTAGES ARE BASED ON TOTAL NEW PRIVATE RECORDS (OWN = 5)					
** COUNTS AND PERCENTAGES EXCLUDE MASTER RECORDS (MEEI = 2)					
**** PERCENTAGES ARE BASED ON ALL ACTIVE CURRENT QUARTER RECORDS					
OTHER PERCENTAGES IN SECTION 6 BASED ON NEW RECS					

EXHIBIT 13F (continued)

DATE: MM/DD/YYYY TIME: 06:06:06 PM		(STATE)		PAGE	27
INITIAL RUN YYYY/Q		EQUI DATA COUNTS - TABLE 3			
BUREAU OF LABOR STATISTICS - EQUI PROCESSING					
		CURRENT	% OF CURR	PREV.QTR	
		QTR TOT	TOTAL RECS	TOTAL	% CHG

SECTION 8 - GEOCODING COUNTS					
LOCATION CODE					

#	PRIVATE RECS WITH 100 OR MORE EMP, TOTAL	2,135	2.09	2,175	-1.83
	MONTH 3 EMPLOYMENT	576,013	41.20	590,293	-2.41
**	# PRIVATE RECS WITH 100 OR MORE EMP, LOC CODE = A OR Z	1,936	90.67	2,017	-4.01
**	MONTH 3 EMPLOYMENT	535,634	92.98	551,064	-2.80
**	# PRIVATE RECS WITH 100 OR MORE EMP, LOC CODE NOT A OR Z	199	9.32	158	25.94
**	MONTH 3 EMPLOYMENT	40,379	7.01	39,229	2.93
**	# PRIVATE RECS WITH 100 OR MORE EMP, LOC CODE = A	1,601	74.98	1,658	-3.43
**	MONTH 3 EMPLOYMENT	431,995	74.99	445,392	-3.00
**	# PRIVATE RECS WITH 100 OR MORE EMP, LOC CODE = Z	335	15.69	359	-6.68
**	MONTH 3 EMPLOYMENT	103,639	17.99	105,672	-1.92
#	PRIVATE (OWN=5) RECS WITH LOC CODE = A (ROOFTOP)	65,731	64.52	64,566	1.80
	MONTH 3 EMPLOYMENT	1,016,460	72.71	1,026,295	-0.95
#	PRIVATE (OWN=5) RECS WITH LOC CODE = Z (ZIP CENTROID)	9,062	8.89	8,935	1.42
	MONTH 3 EMPLOYMENT	192,293	13.75	194,438	-1.10
#	PRIVATE (OWN=5) RECS WITH LOC CODE = A99 (STATE-DERIVED)	0	0.00	0	0.00
	MONTH 3 EMPLOYMENT	0	0.00	0	0.00
#	FEDERAL (OWN=1) RECS WITH LOC CODE = A (ROOFTOP)	82	12.59	83	-1.20
	MONTH 3 EMPLOYMENT	4,461	15.73	4,536	-1.65
#	FEDERAL (OWN=1) RECS WITH LOC CODE = Z (ZIP CENTROID)	40	6.14	38	5.26
	MONTH 3 EMPLOYMENT	358	1.26	349	2.57
#	FEDERAL (OWN=1) RECS WITH LOC CODE = A99 (STATE-DERIVED)	0	0.00	0	0.00
	MONTH 3 EMPLOYMENT	0	0.00	0	0.00
#	STATE GOVT (OWN=2) RECS WITH LOC CODE = A (ROOFTOP)	389	45.81	370	5.13
	MONTH 3 EMPLOYMENT	53,398	59.77	50,196	6.37
#	STATE GOVT (OWN=2) RECS WITH LOC CODE = Z (ZIP CENTROID)	66	7.77	65	1.53
	MONTH 3 EMPLOYMENT	19,339	21.64	18,477	4.66
#	STATE GOVT (OWN=2) RECS WITH LOC CODE = A99 (STATE-DERIVED)	0	0.00	0	0.00
	MONTH 3 EMPLOYMENT	0	0.00	0	0.00
#	LOCAL GOVT (OWN=3) RECS WITH LOC CODE = A (ROOFTOP)	1,064	60.01	1,074	-0.93
	MONTH 3 EMPLOYMENT	144,762	71.87	148,301	-2.38
#	LOCAL GOVT (OWN=3) RECS WITH LOC CODE = Z (ZIP CENTROID)	373	21.03	372	0.26
	MONTH 3 EMPLOYMENT	31,745	15.76	30,886	2.78
#	LOCAL GOVT (OWN=3) RECS WITH LOC CODE = A99 (STATE-DERIVED)	0	0.00	0	0.00
	MONTH 3 EMPLOYMENT	0	0.00	0	0.00

COUNTS AND PERCENTAGES EXCLUDE MEEI = 2,4,5 AND COUNTY = 995,996,998,999					
PERCENTAGES ARE BASED ON RESPECTIVE OWNERSHIPS					
**	PERCENTAGES ARE BASED ON TOTAL PRIVATE RECS WITH 100 OR MORE EMP				

EXHIBIT 13G

DATE: MM/DD/YYYY TIME: 06:06:00 AM (STATE) PAGE 1 INITIAL RUN: YYYY/Q EIN MATRIX MAP - - TABLE 4A BUREAU OF LABOR STATISTICS - EQUI PROCESSING									
FIELD POSITION									
	1	2	3	4	5	6	7	8	9
CHARACTER = 0	5,380	4,537	45,536	17,745	15,642	15,231	15,844	15,270	17,165
1	1,306	10,009	59,843	16,073	11,937	11,280	11,179	11,514	11,227
2	1,359	2,586	3,779	22,880	10,282	10,958	10,945	10,803	10,739
3	3,376	85,164	2,852	10,341	10,359	11,150	11,131	11,898	11,221
4	1,758	4,449	1,050	4,569	10,549	11,874	10,949	11,101	11,011
5	2,237	2,810	116	6,844	10,545	11,011	10,863	10,758	10,927
6	878	2,198	1,552	7,939	11,234	10,824	11,088	11,497	10,696
7	2,328	1,454	318	10,172	11,166	11,152	10,867	10,786	10,773
8	2,664	1,747	83	9,756	11,398	10,780	11,683	10,975	10,901
9	94,237	569	394	9,204	12,411	11,263	10,974	10,921	10,863
ALPHABETIC	0	0	0	0	0	0	0	0	0
BLANK	0	0	0	0	0	0	0	0	0
OTHER	0	0	0	0	0	0	0	0	0
TOTAL NUMBER OF RECORDS ON THE MICRO FILE								190,577	
TOTAL NUMBER OF INACTIVE RECORDS								75,054	
NUMBER OF RECORDS WITH VALID EIN NUMBERS (EXCLUDING ZERO-FILLED)								111,830	
NUMBER OF RECORDS WITH ZERO-FILLED EIN NUMBERS								3,691	
NUMBER OF RECORDS WITH INVALID EIN NUMBERS (NON-NUMRIC OR NINE-FILLED)								2	
*** END OF EIN MATRIX LISTING ***									

EXHIBIT 13H

DATE: MM/DD/YYYY TIME: 06:06:00 AM (STATE) PAGE 1 INITIAL RUN: YYYY/Q UI NUMBER MATRIX MAP - - TABLE 4B BUREAU OF LABOR STATISTICS - EQUI PROCESSING										
FIELD POSITION										
	1	2	3	4	5	6	7	8	9	10
CHARACTER = 0	115,523	115,523	115,523	81,039	23,688	17,548	12,894	12,368	12,197	12,072
1	0	0	0	34,484	18,203	17,386	12,501	11,811	11,586	12,124
2	0	0	0	0	8,186	13,498	12,485	11,501	12,195	11,605
3	0	0	0	0	13,007	6,990	11,706	11,191	11,449	11,045
4	0	0	0	0	4,916	5,634	12,343	11,465	11,277	11,049
5	0	0	0	0	4,954	9,102	13,144	11,404	11,727	11,431
6	0	0	0	0	14,362	9,716	10,523	11,270	11,274	11,565
7	0	0	0	0	662	13,082	9,939	12,104	11,007	11,581
8	0	0	0	0	15,857	11,288	9,408	11,082	11,536	11,633
9	0	0	0	0	11,688	11,279	10,580	11,327	11,275	11,418
ALPHABETIC	0	0	0	0	0	0	0	0	0	0
BLANK	0	0	0	0	0	0	0	0	0	0
OTHER	0	0	0	0	0	0	0	0	0	0

TOTAL NUMBER OF RECORDS ON THE MICRO FILE	190,577
TOTAL NUMBER OF INACTIVE RECORDS	75,054
NUMBER OF RECORDS WITH VALID UI NUMBERS (EXCLUDING ZERO-FILLED)	115,523
NUMBER OF RECORDS WITH ZERO-FILLED UI NUMBERS	0
NUMBER OF RECORDS WITH INVALID UI NUMBERS (NON-NUMERIC OR NINE-FILLED)	0

*** END OF UI NUMBER MATRIX LISTING ****

EXHIBIT 13I

DATE: MM/DD/YYYY		TIME: 06:06:00 AM		(STATE)		PAGE		1		
INITIAL RUN: YYYY/Q		RUN MATRIX MAP - - TABLE 4C								
BUREAU OF LABOR STATISTICS - EQUI PROCESSING										
FIELD POSITION										
		1	2	3	4	5				
CHARACTER = 0		115,523	115,468	114,087	107,621	101,120				
1		0	55	823	2,987	2,242				
2		0	0	327	1,642	2,110				
3		0	0	107	965	1,903				
4		0	0	60	627	1,700				
5		0	0	50	493	1,533				
6		0	0	13	399	1,420				
7		0	0	13	328	1,282				
8		0	0	22	244	1,152				
9		0	0	21	217	1,061				
ALPHABETIC		0	0	0	0	0				
BLANK		0	0	0	0	0				
OTHER		0	0	0	0	0				
TOTAL NUMBER OF RECORDS ON THE MICRO FILE							190,577			
TOTAL NUMBER OF INACTIVE RECORDS							75,054			
NUMBER OF RECORDS WITH VALID RUN NUMBERS (EXCLUDING ZERO-FILLED)							15,458			
NUMBER OF RECORDS WITH ZERO-FILLED RUN NUMBERS							100,065			
NUMBER OF RECORDS WITH INVALID RUN NUMBERS (NON-NUMERIC OR NINE-FILLED)							0			
*** END OF RUN NUMBER MATRIX LISTING ****										

EXHIBIT 13M

DATE: MM/DD/YYYY		TIME: 06:06:00 AM		(STATE)	PAGE	1	
INITIAL RUN: YYYY/Q		RECORD COUNTS BY VALID COUNTY/TOWNSHIP CODES - TABLE 6					
BUREAU OF LABOR STATISTICS - EQUI PROCESSING							
COUNTY CODE	TOWNSHIP CODE	COUNTY NAME	TOWNSHIP NAME	NUMBER OF RECORDS			
001	000	BAKER		699			
003	000	BENTON		579			
005	000	CLACKAMAS		1,096			
007	000	CLATSOP		3,183			
009	000	COLUMBIA		986			
011	000	COOS		334			
013	000	CROOK		151			
015	000	CURRY		780			
017	000	DESCHUTES		362			
019	000	DOUGLAS		609			
021	000	GILLIAM		482			
023	000	GRANT		586			
025	000	HARNEY		123			
027	000	HOOD RIVER		736			
029	000	JACKSON		444			
031	000	JEFFERSON		2,399			
033	000	JOSEPHINE		1,011			
035	000	KLAMATH		1,171			
037	000	LAKE		451			
039	000	LANE		304			
041	000	LINCOLN		464			
043	000	LINN		509			
045	000	MALHEUR		1,623			
047	000	MARION		320			
049	000	MORROW		204			
051	000	MULTNOMAH		2,688			
053	000	POLK		289			
055	000	SHERMAN		802			
057	000	TILLAMOOK		525			
059	000	UMATILLA		593			
061	000	UNION		369			
063	000	WALLOWA		872			
065	000	WASCO		260			
067	000	WASHINGTON		562			
069	000	WHEELER		1,842			
071	000	YAMHILL		432			
900	000	MASTER RECORD		182			
995	000	STATEWIDE, LOCS IN MORE THAN 1 CNTY		466			
998	000	OUT OF STATE		228			
999	000	UNKNOWN LOCATIONS		202			
STATE TOTAL				29,918			

*** END OF VALID COUNTY/TOWNSHIPS CODES ***

EXHIBIT 13N

DATE: MM/DD/YYYY		TIME: 06:06:06 PM		(STATE)			PAGE	1
INITIAL RUN		YYYY/Q		EDIT PARAMETER AND TOLERANCE LISTING - TABLE 7				
		BUREAU OF LABOR STATISTICS - EQUI PROCESSING						
EDIT CODE	EDIT CHECKS	PARAMETER/TOLERANCE NAME	EXPO PK#	WIN PK#	PROD PARAMETER VALUES	STATE PARAMETER VALUES	BLS PARAMETER VALUES	
045	EIN EDIT	AME FOR EIN EDIT		070	000250	000005	000005	
047	TAX RATE RANGE	MAXIMUM TAX RATE	001	001	015000	015000	015000	
047	TAX RATE RANGE	MINIMUM TAX RATE	002	002	000000	000000	000000	
048	COMMENT ERROR	COMMENT ERROR AME	056	063	000010	000000	000010	
063	CONTRIBUTIONS > TAXABLE WAGES	EMPLOYEE TAX RATE	051	003	000000	000000	003000	
066	PREDECESSOR ACCOUNT FORMAT	PREDECESSOR AND SUCCESSOR AME CUTOFF	006	004	000000	000000	000000	
067	SUCCESSOR ACCOUNT FORMAT	PREDECESSOR AND SUCCESSOR AME CUTOFF	006	004			0000000000	
070	ADDRESS EDIT	ADDRESS AME ADDRESS EDIT CUTOFF	--	--	000005		000005	
088	PLA ADDRESS EDIT	PLA ADDRESS PARM					000100	
072	TRADE AND LEGAL NAME EDIT	CUTOFF PARM FOR TRADE/LEGAL NAME	--	--	000003		000003	
091/126	MONTHLY EMPLOYMENT CHANGE (MICRO/MACRO)	SPLIT LEVEL FOR EMPLOYMENT DIFFERENCE	010	005	20	20	20	
091/126	MONTHLY EMPLOYMENT CHANGE (MICRO/MACRO)	LOW EMPLOYMENT MAX EMPLOYMENT DIFFERENCE	011	006	10	10	15	
091/126	MONTHLY EMPLOYMENT CHANGE (MICRO/MACRO)	HIGH EMPLOYMENT MAX EMPLOYMENT DIFFERENCE	012	007	30	30	40	
091/126	MONTHLY EMPLOYMENT CHANGE (MICRO/MACRO)	HIGH REPORTING PERCENT CHANGE	013	008	10	10	15	
091/126	MONTHLY EMPLOYMENT CHANGE (MICRO/MACRO)	REPORTING PERCENT CHANGE	014	009	30	30	30	
091/126	MONTHLY EMPLOYMENT CHANGE	EMPLOYMENT CHECK MULTILPIER	053	010	10	10	10	
091/126	SMALL RECORD BYPASS	SMALL RECORD BYPASS			000015		000025	
091/126	SMALL MACRO RECORD BYPASS	SMALL MACRO RECORD BYPASS			000000040		000000100	
091/126	ESTABLISHMENT LIMIT	NUMER OF ESTABLISHMENTS LIMIT			000100		000100	
091/126	NON ZERO EMPLOYMENT CUTOFF	NON ZERO EMPLOYMENT CUTOFF			000050		000050	

EXHIBIT 130

DATE: MM/DD/YYYY TIME: 06:06:06 PM		(STATE)			PAGE 1		
INITIAL RUN YYYY/Q		EDIT CODE SUMMARY - TABLE 8					
BUREAU OF LABOR STATISTICS - EQUI PROCESSING							
----- <u>TOTAL FLAGGED</u> -----							
----- <u>FLAGGED AND PRINTED</u> -----							
		<u>CURRENT</u>	<u>PRIOR</u>	<u>OTHER BACK</u>	<u>CURRENT</u>	<u>PRIOR</u>	<u>OTHER BACK</u>
		<u>QUARTER</u>	<u>QUARTER</u>	<u>QUARTERS</u>	<u>QUARTER</u>	<u>QUARTER</u>	<u>QUARTERS</u>
TOTAL MICRO RECORDS READ	:	152,712					
ACTIVE MICRO RECORDS READ	:	117,401	115,857	554,159			
NUMBER OF MACRO CELLS	:	19,243					
MACRO CELLS WITH NO MACRO FLAGS	:	19,134	19,173	95,765	0	0	0
MACRO CELLS WITH MACRO FLAGS	:	109	70	450	0	0	0
TOTAL NUMBER OF MACRO FLAGS	:	116	73	464	0	0	0
MICRO RECORDS WITH NO MICRO FLAGS (001-164)	:	150,147	152,026	760,500	0	0	0
MICRO RECORDS WITH MICRO FLAGS (001-164)	:	2,565	686	3,060	0	0	0
TOTAL NUMBER OF MICRO FLAGS (001-164)	:	2,938	698	3,086	0	0	0
RECORDS WITH MICRO I ERRORS (001-080)	:	0	0	0	0	0	0
TOTAL NUMBER OF MICRO I ERRORS (001-080)	:	0	0	0	0	0	0
RECORDS WITH MICRO W FLAGS (088-164)	:	2,565	686	3,060	0	0	0
TOTAL NUMBER OF MICRO W FLAGS (088-164)	:	2,938	698	3,086	0	0	0
NUMBER OF ACTIVE MULTI ACCOUNTS	:	1,333	1,336	6,644	0	0	0
MULTI ACCOUNTS WITH NO FLAGS (171-185)	:	1,332	1,336	6,643	0	0	0
MULTI ACCOUNTS WITH FLAGS (171-185)	:	1	0	1	0	0	0
NUMBER OF MULTI FLAGS COUNTED BY UI ACCOUNT (171-185)	:	2	0	1	0	0	0
TOTAL NUMBER OF WORKSITES IN ACCOUNTS WITH MULTI FLAGS (171-185)	:	2	0	0	0	0	0
** MACRO CELLS WITH A-LIST FLAGS	:	109	70	450	0	0	0
TOTAL NUMBER OF MACRO A-LIST FLAGS	:	116	73	464	0	0	0
MICRO RECORDS WITH A-LIST FLAGS	:	726	686	3,058	0	0	0
TOTAL NUMBER OF MICRO A-LIST FLAGS	:	753	698	3,084	0	0	0
MULTI ACCOUNTS WITH A-LIST FLAGS	:	1	0	1	0	0	0
TOTAL NUMBER OF MULTI ACCOUNT A-LIST FLAGS	:	2	0	1	0	0	0
MICRO RECORDS WITH B-LIST FLAGS	:	38	0	1	0	0	0
TOTAL NUMBER OF MICRO B-LIST FLAGS	:	38	0	1	0	0	0
MICRO RECORDS WITH C-LIST FLAGS	:	1,822	0	1	0	0	0
TOTAL NUMBER OF MICRO C-LIST FLAGS	:	2,147	0	1	0	0	0
** A-LIST: MICRO EDIT CODES: 002-006,010,012,013,016,025,031-036,039,040,045,056-060,062-065,070,072,080,091-097,116,126,127,130-133,139,140,160,161							
MACRO EDIT CODES: 091-094,126,127,130,131,134,135; MULTI ACCOUNT EDIT CODES: 171-174,178-185							
B-LIST: MICRO EDIT CODES: 041,043,044,046,066,067,074-076,078,088,120,121,123,142,146,156,157,159,162,164							
C-LIST: MICRO EDIT CODES: 001,021-024,048-052,101-112,114,118,119,124,125,128,129							

EXHIBIT 13O (continued)

DATE: MM/DD/YYYY TIME: 06:06:06 PM		(STATE)			PAGE 2		
INITIAL RUN YYYY/Q		EDIT CODE SUMMARY - TABLE 8					
BUREAU OF LABOR STATISTICS - EQUI PROCESSING							
-----TOTAL FLAGGED-----				-----FLAGGED AND PRINTED-----			
	CURRENT QUARTER	PRIOR QUARTER	OTHER BACK QUARTERS	CURRENT QUARTER	PRIOR QUARTER	OTHER BACK QUARTERS	
** RECORDS WITH PUBLICATION EDIT FLAGS	0	0	0	0	0	0	0
TOTAL NUMBER OF PUBLICATION EDIT FLAGS	0	0	0	0	0	0	0
-----EMPLOYMENT-----							
	CURRENT QUARTER	PRIOR QUARTER	OTHER BACK QUARTERS				
MONTH 3 EMPLOYMENT FOR RECORDS WITH PUBLICATION EDIT FLAGS :		0	0	0			
-----TOTAL FLAGGED-----				-----FLAGGED AND PRINTED-----			
EDIT MESSAGES	EDIT CODE	CURRENT QUARTER	PRIOR QUARTER	OTHER BACK QUARTERS	CURRENT QUARTER	PRIOR QUARTER	OTHER BACK QUARTERS
MACRO EDIT FLAGS (CODES 091-135)	TOTAL	116	73	464	0	0	0
EMPLOYMENT CHANGE GREATLY EXCEEDS TEST PARAMETERS	091	9	6	62	0	0	0
AQW CHANGE IS SIGNIFIANTLY > \$PARM AND EXCEEDS TWICE THE QUARTILE AQW RANGE	092	36	23	87	0	0	0
AVERAGE EMPLOYMENT IS SIGNIFICANTLY > \$PARM, BUT TOTAL WAGES = \$0	093	0	0	0	0	0	0
AVERAGE EMPLOYMENT = 0, BUT TOTAL WAGES IS SIGNIFICANTLY > \$PARM	094	0	0	0	0	0	0
EMPLOYMENT CHANGE EXCEEDS TEST PARAMETERS	126	29	18	182	0	0	0
AQW CHANGE > \$PARM AND EXCEEDS TWICE THE QUARTILE AQW RANGE	127	17	13	26	0	0	0
AVERAGE EMPLOYMENT > \$PARM, BUT TOTAL TOTAL WAGES = \$0	130	0	0	0	0	0	0
AVERAGE EMPLOYMENT = 0, BUT TOTAL WAGES > \$PARM	131	0	0	0	0	0	0
NUMBER OF ESTABLISHMENTS OUT OF RANGE	134	23	13	107	0	0	0
NEW OR DISCONTINUED MACRO RECORD	135	2	0	0	0	0	0
** PUBLICATION EDITS: MICRO EDIT CODES: 010,012,013,016,025,031-036,039,040,056-060,062,063							
ANY RECORDS CARRYING THESE ERRORS WILL BE EXCLUDED FROM BLS DATA EXTRACTS FOR NONDISCLOSURE PROCESSING.							

EXHIBIT 130 (continued)

DATE: MM/DD/YYYY	TIME: 06:06:06 PM	(STATE)	PAGE	3			
INITIAL RUN	YYYY/Q	EDIT CODE SUMMARY - TABLE 8					
BUREAU OF LABOR STATISTICS - EQUI PROCESSING							
<u>EDIT MESSAGES</u>	----- <u>TOTAL FLAGGED</u> -----			----- <u>FLAGGED AND PRINTED</u> -----			
	<u>EDIT CODE</u>	<u>CURRENT QUARTER</u>	<u>PRIOR QUARTER</u>	<u>OTHER BACK QUARTERS</u>	<u>CURRENT QUARTER</u>	<u>PRIOR QUARTER</u>	<u>OTHER BACK QUARTERS</u>
MICRO EDIT FLAGS (LEVELS 1-7, CODES 001-164)	TOTAL	2,938	698	3,086	0	0	0
PRE-EDIT-FLAGS (LEVEL ONE, CODES 001-006)	TOTAL	0	0	0	0	0	0
INVALID TRANSACTION CODE	001	0	0	0	0	0	0
INVALID UI ACCOUNT NUMBER	002	0	0	0	0	0	0
INVALID REPORTING UNIT NUMBER	003	0	0	0	0	0	0
INVALID REFERENCE YEAR	004	0	0	0	0	0	0
INVALID REFERENCE QUARTER	005	0	0	0	0	0	0
INVALID STATE CODE	006	0	0	0	0	0	0
KEY FIELD EDIT FLAGS (LEVEL TWO, CODES 010-016) TOTAL	TOTAL	0	0	0	0	0	0
INVALID NAICS CODE	010	0	0	0	0	0	0
INVALID OWNERSHIP CODE	012	0	0	0	0	0	0
INVALID COUNTY CODE	013	0	0	0	0	0	0
NAICS AND OWNERSHIP INCONSISTENT	016	0	0	0	0	0	0
DATES AND STATUS CODE CHECKS (LEVEL THREE, CODES 021-025)	TOTAL	0	0	0	0	0	0
INVALID LIABILITY DATE FORMAT	021	0			0		
INVALID EOL DATE FORMAT	022	0			0		
INVALID SETUP DATE FORMAT	023	0			0		
REACTIVATION DATE FORMAT INVALID OR EARLIER THAN LIABILITY DATE	024	0			0		
INVALID STATUS CODE	025	0	0	0	0	0	0
REMAINING INVALID ERRORS (LEVEL FOUR FOUR CODES, 031-080)	TOTAL	0	0	0	0	0	0
INVALID FIRST MONTH EMPLOYMENT	031	0	0	0	0	0	0
INVALID SECOND MONTH EMPLOYMENT	032	0	0	0	0	0	0
INVALID THIRD MONTH EMPLOYMENT	033	0	0	0	0	0	0
INVALID TOTAL WAGES	034	0	0	0	0	0	0
INVALID TAXABLE WAGES	035	0	0	0	0	0	0
INVALID CONTRIBUTIONS	036	0	0	0	0	0	0

PRE-EDIT FLAG TOTALS ARE NOT CURRENTLY INCLUDED. THEY WILL BE INCLUDED IN FUTURE VERSIONS. SEE TABLE 1B FOR PRE-EDIT FLAGS.
 PRIOR QUARTER AND OTHER BACK QUARTER TOTALS MAY INCLUDE EDITS THAT HAVE BEEN DISCONTINUED.

EXHIBIT 130 (continued)

DATE: MM/DD/YYYY TIME: 06:06:06 PM		(STATE)			PAGE 4		
INITIAL RUN YYYY/Q		EDIT CODE SUMMARY - TABLE 8					
BUREAU OF LABOR STATISTICS - EQUI PROCESSING							
<u>EDIT MESSAGES</u>	-----TOTAL FLAGGED-----			-----FLAGGED AND PRINTED-----			
	<u>EDIT CODE</u>	<u>CURRENT QUARTER</u>	<u>PRIOR QUARTER</u>	<u>OTHER BACK QUARTERS</u>	<u>CURRENT QUARTER</u>	<u>PRIOR QUARTER</u>	<u>OTHER BACK QUARTERS</u>
INVALID TYPE OF COVERAGE	039	0	0	0	0	0	0
INVALID MEEI CODE	040	0	0	0	0	0	0
INVALID AUXILARY CODE	041	0	0	0	0	0	0
INVALID PREDECESSOR SESA ID	043	0	0	0	0	0	0
INVALID SUCCESSOR SESA ID	044	0	0	0	0	0	0
INVALID FEDERAL EI NUMBER	045	0	0	0	0	0	0
INVALID ARS RESPONSE CODE/YEAR	046	0	0	0	0	0	0
INVALID COMMENT CODE	048	0	0	0	0	0	0
INVALID FIRST MONTH EMPLOYMENT INDICATOR	049	0	0	0	0	0	0
INVALID SECOND MONTH EMPLOYMENT INDICATOR	050	0	0	0	0	0	0
INVALID THIRD MONTH EMPLOYMENT INDICATOR	051	0	0	0	0	0	0
INVALID TOTAL WAGES INDICATOR	052	0	0	0	0	0	0
INCONSISTENT OWNERSHIP/TYPE OF COVERAGE	056	0	0	0	0	0	0
TAXABLE WAGES ON FEDERAL RECORD	057	0	0	0	0	0	0
CONTRIBUTIONS ON FEDERAL RECORD	058	0	0	0	0	0	0
TAXABLE WAGES > 0 FOR NONEXPERIENCE-RATED RECORD	059	0	0	0	0	0	0
CONTRIBUTIONS > 0 FOR NONEXPERIENCE RATED RECORD	060	0	0	0	0	0	0
TAXABLE WAGES > TOTAL WAGES	062	0	0	0	0	0	0
CONTRIBUTIONS > TAXABLE WAGES	063	0	0	0	0	0	0
MEEI/REPORTING UNIT # INCONSISTENT	064	0	0	0	0	0	0
INCONSISTENT COUNTY/TOWNSHIP COMBINATION	065	0	0	0	0	0	0
INVALID FORMAT IN PREDECESSOR ACCOUNT	066	0	0	0	0	0	0
INVALID FORMAT IN SUCCESSOR ACCOUNT	067	0	0	0	0	0	0
NO USABLE ADDRESS	070	0	0	0	0	0	0
BOTH TRADE AND LEGAL NAME ARE BLANK	072	0	0	0	0	0	0
INVALID OLD OWNERSHIP	074	0	0	0	0	0	0
INVALID OLD COUNTY	075	0	0	0	0	0	0
INVALID OLD COUNTY/TOWNSHIP COMBINATION	076	0	0	0	0	0	0
INVALID OLD NAICS CODE	078	0	0	0	0	0	0
INDIAN TRIBAL INDICATOR INCONSISTENT WITH NAICS OR OWN	080	0	0	0	0	0	0

EXHIBIT 130 (continued)

DATE: MM/DD/YYYY TIME: 06:06:06 PM		(STATE)			PAGE 5		
INITIAL RUN YYYY/Q		EDIT CODE SUMMARY - TABLE 8					
BUREAU OF LABOR STATISTICS - EQUI PROCESSING							
<u>EDIT MESSAGES</u>	-----TOTAL FLAGGED-----			-----FLAGGED AND PRINTED-----			
	<u>EDIT CODE</u>	<u>CURRENT QUARTER</u>	<u>PRIOR QUARTER</u>	<u>OTHER BACK QUARTERS</u>	<u>CURRENT QUARTER</u>	<u>PRIOR QUARTER</u>	<u>OTHER BACK QUARTERS</u>
SIGNIFICANT EMPLOYMENT AND WAGE FLAGS (LEVEL FIVE, CODES 091-097)							
TOTAL		195	189	672	0	0	0
EMPLOYMENT CHANGE GREATLY EXCEEDS TEST PARAMETERS	091	43	37	220	0	0	0
AQW CHANGE IS SIGNIFICANTLY > \$PARM AND EXCEEDS TWICE THE QUARTILE AQW RANGE	092	146	152	450	0	0	0
AVERAGE EMPLOYMENT IS SIGNIFICANTLY > \$PARM, BUT TOTAL WAGES = \$0	093	0	0	0	0	0	0
AVERAGE EMPLOYMENT = 0, BUT TOTAL WAGES IS SIGNIFICANTLY > \$PARM	094	0	0	1	0	0	0
TOTAL WAGES = SUM OF EMPLOYMENT +/- \$PARM IF AME IS LARGE	095	0	0	0	0	0	0
UNUSUALLY LARGE NEW RECORD ON FILE	096	2	0	0	0	0	0
UNUSUALLY LARGE DISCONTINUED RECORD INACTIVATED	097	4	0	1	0	0	0
** WARNING EDIT FLAGS (LEVEL SIX, CODES 088 AND 101-146)							
TOTAL		2,738	509	2,414	0		
LARGE RECORD WITHOUT USABLE PLA	088	32			0		
UNUSABLE MOA ADDRESS TYPE CODE	101	1,624			0		
BLANK PHYSICAL LOCATION CITY, OTHER PLA FIELDS PRESENT	102	93			0		
UNUSABLE PHYSICAL LOCATION STATE ABBREVIATION	103	114			0		
UNUSABLE PHYSICAL LOCATION ZIP CODE FORMAT	104	58			0		
UNUSABLE TELEPHONE FORMAT	105	0			0		
BLANK UI CITY, OTHER UI ADDRESS FIELDS PRESENT	106	5			0		
UNUSABLE UI STATE ABBREVIATION	107	14			0		
UNUSABLE UI ZIP CODE FORMAT	108	14			0		
BLANK MAILING/OTHER CITY, OTHER M/O ADDRESS FIELDS PRESENT	109	20			0		
UNUSABLE MAILING/OTHER STATE ABBREVIATION	110	32			0		
UNUSABLE MAILING/OTHER ZIP CODE FORMAT	111	9			0		
QUESTIONABLE FAX NUMBER FORMAT	112	0			0		
PHYSICAL ADDRESS ERROR--P O BOX, BLANK STREET OR OUT-OF-STATE IN PHYSICAL ADDRESS BLOCK	114	163			0		
EIN MISSING FOR MORE THAN \$PARM MONTHS	116	1			0		
COMPUTED TAX RATE > \$TOL% FROM REPORTED, AND COMPUTED TAX > \$TOL FROM REPORTED	118	0	0	0	0	0	0
** ADDRESS FLAGS 101-114 WILL NOT APPEAR ON TABLE 9B UNLESS THE RECORDS FAILS EDIT CODE 70 (NO USEABLE ADDRESS).							

EXHIBIT 130 (continued)

DATE: MM/DD/YYYY		TIME: 06:06:06 PM		(STATE)			PAGE 6	
INITIAL RUN YYYY/Q		EDIT CODE SUMMARY - TABLE 8						
BUREAU OF LABOR STATISTICS - EQUI PROCESSING								
<u>EDIT MESSAGES</u>		----- <u>TOTAL FLAGGED</u> -----			----- <u>FLAGGED AND PRINTED</u> -----			
	<u>EDIT CODE</u>	<u>CURRENT QUARTER</u>	<u>PRIOR QUARTER</u>	<u>OTHER BACK QUARTERS</u>	<u>CURRENT QUARTER</u>	<u>PRIOR QUARTER</u>	<u>OTHER BACK QUARTERS</u>	
FIRST QUARTER TAXABLE WAGES MISSING FOR AN EXPERIENCE-RATED ACCOUNT								
	119	0	0	0	0	0	0	
POSSIBLE NONECONOMIC CODE CHANGE								
	120	1	0	0	0	0	0	
CODE CHANGE BACK TO A RECENT CODE								
	121	1	0	0	0	0	0	
EXPECTED CODE CHANGE NOT MADE								
	123	4			0			
INACTIVE RECORD WITH REPORTED EMPLOYMENT/WAGE DATA								
	124	1			0			
DATA REPORTED PRIOR TO LIABILITY DATA								
	125	0			0			
EMPLOYMENT CHANGE EXCEEDS TEST PARAMETERS								
	126	418	297	2,052	0	0	0	
AQW CHANGE > \$PARM AND EXCEEDS TWICE THE QUARTILE AQW RANGE								
	127	108	212	354	0	0	0	
IDENTICAL MONTHLY EMPLOYMENT > \$PARM								
	128	0	0	0	0	0	0	
TAXABLE/TOTAL WAGE RATIO EXCEEDS PRIOR YEAR RATIO BY \$PARM%								
	129	0	0	1	0	0	0	
AVERAGE EMPLOYMENT > \$PARM, BUT TOTAL WAGES = \$0								
	130	0	0	0	0	0	0	
AVERAGE EMPLOYMENT = 0, BUT TOTAL WAGES > \$PARM								
	131	0	0	2	0	0	0	
TOTAL WAGES = SUM OF EMPLOYMENT +/- \$PARM								
	132	0	0	0	0	0	0	
UNCLASSIFIED INDUSTRY, EMPLOYMENT > PARM								
	133	2	0	0	0	0	0	
NEW RECORD?								
	139	19	0	0	0	0	0	
DISCONTINUED RECORD?								
	140	5	0	4	0	0	0	
INCONSISTENT AUXILIARY/NAICS COMBINATION								
	142	0	0	1	0	0	0	
OLD CODES ARE NOT CONSISTENT WITH 4TH QTR CODES								
	146	0			0			
PREDECESSOR/SUCCESSOR EDIT FLAGS (LEVEL 7, CODES 151-164)								
	TOTAL	5			0			
PREDECESSOR/SUCCESSOR ACCOUNT DISCREPANCY								
	151	0			0			
PREDECESSOR END OF LIABILITY DATE ERROR								
	152	0			0			
SUCCESSOR REPORTED PRIOR TO LIABILITY DATE								
	153	0			0			
SUCCESSOR REPORTED LATER THAN LIABILITY DATE								
	154	0			0			
DATA REPORTED FOR RECORD CODED								
	155				0			
OUT-OF-BUSINESS								
PREDECESSOR/SUCCESSOR COUNTY CODE CHANGE CONFLICT								
	156	0			0			
PREDECESSOR/SUCCESSOR OWNERSHIP CODE CHANGE CONFLICT								
	157	0			0			

EXHIBIT 130 (continued)

DATE: MM/DD/YYYY TIME: 06:06:06 PM		(STATE)			PAGE 7		
INITIAL RUN YYYY/Q		EDIT CODE SUMMARY - TABLE 8					
		BUREAU OF LABOR STATISTICS - EQUI PROCESSING					
<u>EDIT MESSAGES</u>	----- <u>TOTAL FLAGGED</u> -----			----- <u>FLAGGED AND PRINTED</u> -----			
	<u>EDIT CODE</u>	<u>CURRENT QUARTER</u>	<u>PRIOR QUARTER</u>	<u>OTHER BACK QUARTERS</u>	<u>CURRENT QUARTER</u>	<u>PRIOR QUARTER</u>	<u>OTHER BACK QUARTERS</u>
PREDECESSOR/SUCCESSOR TOWNSHIP CODE CHANGE CONFLICT	159	0			0		
BOTH PREDECESSOR AND SUCCESSOR REPORTED	160	4			0		
NEITHER PREDECESSOR NOR SUCCESSOR REPORTED	161	1			0		
QUESTIONABLE INCONSISTENCIES RESULT IN PRED/SUCC RELATIONSHIP	162	0			0		
PREDECESSOR/SUCCESSOR NAICS CODE CHANGE CONFLICT	164	0			0		
MULTI FLAGS COUNTED BY UI ACCOUNT (LEVEL 8, CODES 171-185)	TOTAL	2	0	1	0	0	0
MULTI OUT OF BALANCE FLAGS COUNTED BY UI ACCOUNT (171-174)		0	0	0	0	0	0
WORKSITES IN ACCOUNTS WITH OUT OF BALANCE FLAGS (171-174)		0	0	0	0	0	0
FIRST MONTH EMPLOYMENT NOT IN BALANCE	171	0	0	0	0	0	0
SECOND MONTH EMPLOYMENT NOT IN BALANCE	172	0	0	0	0	0	0
THIRD MONTH EMPLOYMENT NOT IN BALANCE	173	0	0	0	0	0	0
TOTAL WAGES NOT IN BALANCE	174	0	0	0	0	0	0
OTHER MULTI FLAGS COUNTED BY UI ACCOUNT (178-185)		2	0	1	0	0	0
WORKSITES IN ACCOUNTS WITH OTHER MULTI FLAGS (178-185)		2	0	0	0	0	0
MASTER WITHOUT MULTIPLE WORKSITES	178	0	0	1	0	0	0
WORKSITE MISSING MASTER	179	1	0	0	0	0	0
SINGLE ACCOUNT/ACTIVE WORKSITES	180	1	0	0	0	0	0
WORKSITE OWNERSHIP CODE DIFFERS FROM MASTER	181	0	0	0	0	0	0
WORKSITE EIN DIFFERS FROM MASTER	182	0	0	0	0	0	0
INCONSISTENT INDIAN TRIBAL CODES WITHIN THE MULTI ACCOUNT	185	0	0	0	0	0	0

DATE: MM/DD/YYYY TIME: 06:07:08 PM
INITIAL RUN YYYY/Q

(STATE)
INTEGRATED MACRO EDIT - TABLE 9A
BUREAU OF LABOR STATISTICS - EQUI PROCESSING

PAGE 1
CONFIDENTIAL DATA

OWNERSHIP:	3	COUNTY:	018	DUCHMASTER	NAICS:	561599	All other travel arrangement services				TOTAL WAGES	
YEAR/Q	AME	OTQ	OTY	AWW	OTQ	OTY	NO.	ESTABL	M1	M2	M3	
	PCT	PCT			PCT	PCT						
2005/2	532	35	52	336	-5	-30	1		473	491	631	2,322,630
2005/1	395	-11	13	354	-45	-19	1		394	393	397	1,815,463
2004/4	444	24	-8	642	57	84	1		458	446	429	3,708,337
2004/3	359	3	-1	410	-15	3	1		352	354	371	1,912,535
2004/2	350	0	-10	483	11	9	1		341	351	358	2,196,153
2004/1	350	-28	-2	436	25	6	1		345	350	355	1,981,702
2003/4	484	34	18	349	-12	-18	1		640	403	408	2,192,860
2003/3	362	-7	-22	398	-11	-5	1		364	368	353	1,872,464

2005/2 MACRO EDIT CODES/MESSAGES:
126-W EMPLOYMENT CHANGE EXCEEDS TEST PARAMETERS

2004/4 MACRO EDIT CODES/MESSAGES:
092-W AQW CHANGE IS SIGNIFICANTLY > PARM AND EXCEEDS TWICE THE QUARTILE AQW RANGE

UI ACCOUNT/RUN: 0011223344 00000 TRADE: CITY OF USA PRED: 0099887766 00000 SETUP: 1980/01/01 AVER
EIN: 987321654 LEGAL: SUCC: REACT: / / 521
LIAB: 1980/01/01 EOL: / /

YEAR/Q	T	E	W	EDI	NAICS	CNT	LEV	OTQ	OTY	LEV	OTQ	OTY	M1	M2	M3	TOTAL WAGES	CC	CC	CC	QVER
2005/2	1	3	3		561599	109	532	137	182	336	-18	-147	473R	491R	631R	2,322,630P	03	35		521
2005/1	1	3	3		561599	109	395	-49	45	354	-288	-82	394R	393R	397R	1,815,463R	04	35		521
2004/4	1	3	3		561599	109	444	85	-40	642	232	293	458R	446R	429R	3,708,337H	05	31		511
2004/3	1	3	3		561599	109	359	9	-3	410	-73	12	352P	354P	371P	1,912,535P				431
2004/2	1	3	3		561599	109	350	0	-39	483	47	38	341P	351P	358P	2,196,153P				421
2004/1	1	3	3		561599	109	350	-134	-7	436	87	24	345R	350R	355R	1,981,702R				411
2003/4	1	3	3		561599	109	484	122	73	349	-49	-79	640R	403R	408R	2,192,860R	05	06		411

ARS RESPONSE CODE: 41 ARS REFILE YEAR: 2003 OLD COUNTY: 109 OLD NAICS: 561599 OLD OWN: 3 OLD TOWN: 000
2005/2 EDIT CODES/MESSAGES:
126-W EMPLOYMENT CHANGE EXCEEDS TEST PARAMETERS
1 OF 1 ASSOCIATED MICRO RECORDS WERE PRINTED FOR ESTBL <= PARM

EXHIBIT 13Q

DATE: MM/DD/YYYY	TIME: 06:07:08 PM	(STATE)	PAGE 1								
INITIAL RUN YYYY/Q		MICRO EDITS ONLY - - TABLE 9B	** CONFIDENTIAL DATA **								
BUREAU OF LABOR STATISTICS - EQUI PROCESSING											
UI ACCOUNT/RUN: 4567890123 00044	TRADE: CITY OF BUBBLE SPRINGS	LEGAL: CITY OF BUBBLE SPRINGS									
EIN: 567890123	LIAB: 2005/01/01 EOL: / /	SETUP: 2004/05/12 REACT: / /	RCI: 0								
PRED:	SUCC:	SPEC: ECCI: 00	CES: ORG:								
S M C O	A	AGENT EDI									
YEAR/Q	T E V W NAICS	SIC X NSTA	CTY TWN	M1	M2	M3	TOTAL WAGES	AWW	TAX. WAGES	CTB	CC CC CC CODE
2005/1 1 1 9 1	926110 9999 5		019 000	314	319	320	4,809,618	1163	0	0	99
2004/4 3				0	0	0	0	0	0	0	
2004/3 3				0	0	0	0	0	0	0	
2004/2 3				0	0	0	0	0	0	0	
2004/1 9 1 0 5	926110 9999 5		019 000	220	222	225	3,281,636	1137	0	0	
2003/4 3				0M	0M	0M	0M	0	0	0	
CURRENT QTR NARRATIVE: First time reporting in over a year											
ARS RESPONSE CODE:	REFILE YEAR:	OLD CODES:	CNTY:	OWN:	NAICS:	TOWN: 000					
-----PHYSICAL LOCATION-----UI ADDRESS-----MAILING/OTHER-----											
STREET ADDRESS-1	20 MILKY WAY				1234 MAIN ST						
STREET ADDRESS-2					ROOM 58						
CITY	BUBBLE SPRINGS				ANYWHERE						
STATE ZIP	UA 23456-				ST 23456-						
					MAILING/OTHER ADDRESS TYPE: 9						
PHONE: 123-456-7890 EXT. 00000 FAX: 123-456-7891 RPRTG UNIT DESC:											
2005/1 EDIT CODES/MESSAGES:											
096-W UNUSUALLY LARGE NEW RECORD ON FILE											

** CONFIDENTIAL DATA ** FOR STATISTICAL USE BY AUTHORIZED PERSONNEL ONLY. DESTROY ACCORDING TO RECORDS RETENTION SCHEDULE.											

EXHIBIT 13R

YEAR/Q	T E V W	NAICS	SIC	X	FLAG	CTY	TWN	M1	M2	M3	TOTAL WAGES	AWW	TAX. WAGES	CTB	CC	CC	CC	CODE	AGENT EDI
2005/2	2				D			0	0	0	0	0	0	0					
2005/1	2	3 0 5	424810	5181	5	D	001 000	147	146	151	1,677,529	872	1,465,626	20,518	91				
2004/4	3							OM	OM	OM	OM	0	0	0					
2004/3	3							OM	OM	OM	OM	0	0	0					
2004/2	3							OM	OM	OM	OM	0	0	0					
2004/1	3							OM	OM	OM	OM	0	0	0					

DATE: MM/DD/YYYY TIME: 06:07:08 PM (STATE) PAGE 1
 INITIAL RUN YYYY/Q MICRO DELETES ONLY -- TABLE 9D ** CONFIDENTIAL DATA **
 BUREAU OF LABOR STATISTICS - EQUI PROCESSING
 UI ACCOUNT/RUN: 0123456789 00044 TRADE: BACON AND EGGS LEGAL:
 EIN: 123456789 LIAB: 2005/01/01 EOL: / / SETUP: 2005/05/31 REACT: / / RCI: CES: ORG:
 PRED: SUCC: SPEC:

ARS RESPONSE CODE: REFILE YEAR: OLD CODES: CNTY: OWN: NAICS: TOWN: 000
 -----PHYSICAL LOCATION-----UI ADDRESS-----MAILING/OTHER-----
 STREET ADDRESS-1 | 3 MAIN STREET | 789 BOARDWALK RD | |
 STREET ADDRESS-2 | | | |
 CITY | ANYWHERE | ANYPLACE | |
 STATE ZIP | UA 12345- | UA 98765-0000 | | - |
 ADDRESS TYPE: PHONE: 123-456-7890 REPORTING UNIT DESCRIPTION:

 ** CONFIDENTIAL DATA ** FOR STATISTICAL USE BY AUTHORIZED PERSONNEL ONLY. DESTROY ACCORDING TO RECORDS RETENTION SCHEDULE.
 *** END OF MICRO DELETES LISTING ****

EXHIBIT 13S

```

DATE: MM/DD/YYYY    TIME: 06:07:08 PM                    (STATE)                    PAGE 1
INITIAL RUN  YYYY/Q    UNUSABLE PHYSICAL LOCATION ADDRESSES - - TABLE 9G    ** CONFIDENTIAL DATA **
BUREAU OF LABOR STATISTICS - EQUI PROCESSING
UI ACCOUNT/RUN: 1234567890 00044    TRADE:                    LEGAL:LEGAL NAME                    EIN: 012345678
LIAB: 1936/11/01 EOL:    / /    REACT:    / /    PRED: 0000012223 00010    SUCC: 0000388888 00007    SPEC:    AVER: 511
CONTACT:                    WEB:
TITLE:                    E-MAIL:
YEAR/Q ST MEEI OWN  NAICS CTY TWN LOC  GS MATCH  LATITUDE  LONGITUDE  PLACE  CENSUS BLOCK  AS  AME AGENT EDI QVER
2005/1 1 3 5 221112 029 000
OLD ARS CODE: RESP: 41  REFILE YEAR: 2004 CNTY:    CMI: 00 | | FUTURE ARS CODES: RESP:    REFILE YEAR:    CNTY:    CMI:
-----PHYSICAL LOCATION-----UI ADDRESS-----MAILING/OTHER-----
STREET ADDRESS-1 | |092 PENGUINS R US ROAD | | |
STREET ADDRESS-2 | | | | |
CITY | | |ANYWHERE | | |
STATE ZIP | | - |UA 12345- | | - |
PLA CHANGED DATE: / / |UI ADDRESS TYPE: 9 |MAILING/OTHER ADDRESS TYPE: |
PHONE: 0- - 0 EXT. 00000 FAX: - - RPRTG UNIT DESC: COLLETON COUNTY
2005/1 EDIT CODES/MESSAGES:
088-W LARGE RECORD WITHOUT USABLE PLA
*****
UI ACCOUNT/RUN: 1234567890 00044    TRADE:                    LEGAL:OFFICE INC.                    EIN: 987654321
LIAB: 1966/06/01 EOL:    / /    REACT:    / /    PRED:                    SUCC:                    SPEC:    AVER: 511
CONTACT:                    WEB:
TITLE:                    E-MAIL:
YEAR/Q ST MEEI OWN  NAICS CTY TWN LOC  GS MATCH  LATITUDE  LONGITUDE  PLACE  CENSUS BLOCK  AS  AME AGENT EDI QVER
2005/1 1 3 5 236220 045 000
OLD ARS CODE: RESP: 41  REFILE YEAR: 2003 CNTY:    CMI: 00 | | FUTURE ARS CODES: RESP:    REFILE YEAR:    CNTY:    CMI:
-----PHYSICAL LOCATION-----UI ADDRESS-----MAILING/OTHER-----
STREET ADDRESS-1 | |P O BOX 1 | | |
STREET ADDRESS-2 | | | | |
CITY | | |ANYWHERE | | |
STATE ZIP | | - |UA 12345- | | - |
PLA CHANGED DATE: / / |UI ADDRESS TYPE: 9 |MAILING/OTHER ADDRESS TYPE: |
PHONE: 0- - 0 EXT. 00000 FAX: - - RPRTG UNIT DESC: OFFICEVILLE
2005/1 EDIT CODES/MESSAGES:
088-W LARGE RECORD WITHOUT USABLE PLA

```

EXHIBIT 13T

DATE: MM/DD/YYYY		TIME: 12:20:28 PM		STATE										PAGE 1							
INITIAL RUN YYYY/Q				LARGE MASTER RECORD EDIT - - TABLE 9M-EMP										** CONFIDENTIAL DATA **							
				BUREAU OF LABOR STATISTICS - EQUI PROCESSING																	
UI ACCOUNT/RUN: 0123456789 98765				TRADE: MEATBALL INC.				PRED:				LIAB: 2001/06/15 AVER: 511									
EIN: 830589112				LEGAL: SPAGHETTI NOODLES				SUCC:				SETUP: 2001/06/15									
NAICS: "Offices of physicians, except mental health"																					
YEAR/Q	S	M	O	NAICS	CTY	LEVEL	OTQ	OTY	LEVEL	OTQ	OTY	UT	ET	M1	M2	M3	TOT W	CC	CC	CC	QVER
2005/1	1	2	5	621111	049	1.5	.2	1.5	.5	0	.5	100	100	1,000	1,500	2,000	10.0	03	01		511
2004/4	1	2	5	621111	049	1.3	0	1.3	.5	0	.5	95	95	2,000	1,000	800	8.0				441
2004/3	1	2	5	621111	049	1.3	0	1.3	.5	0	.5	95	95	800	1,000	800	8.8	03			441
2004/2	1	2	5	621111	049	1.3	1.3	1.3	.5	.5	.5	95	95	800	1,000	800	8.8	85			431
2004/1	2	2	5	621111	049	0	0	0	0	0	0	0	0	0	0	0	0				412
2003/4	2	2	5	621111	049	0	0	0	0	0	0	0	0	0	0	0	0				341
2003/3	2	2	5	621111	049	0	0	0	0	0	0	0	0	0	0	0	0				331
2002/2 EDIT CODES/MESSAGES:																					
091-W EMPLOYMENT CHANGE GREATLY EXCEEDS TEST PARAMETERS																					

UI ACCOUNT/RUN: 0123456789 98765				TRADE:				PRED:				LIAB: 2001/06/15 AVER: 511									
EIN: 814071669				LEGAL: NEW MARKETS CONSULTING				SUCC:				SETUP: 2001/06/15									
NAICS: "Offices of physicians, except mental health"																					
YEAR/Q	S	M	O	NAICS	CTY	LEVEL	OTQ	OTY	LEVEL	OTQ	OTY	UT	ET	M1	M2	M3	TOT W	CC	CC	CC	QVER
2005/1	1	2	5	621111	049	1.5	.2	1.5	.5	0	.5	100	100	1,000	1,500	2,000	10.0	03	01		511
2004/4	1	2	5	621111	049	1.3	0	1.3	.5	0	.5	95	95	2,000	1,000	800	8.0				511
2004/3	1	2	5	621111	049	1.3	0	1.3	.5	0	.5	95	95	800	1,000	800	8.8	03			431
2004/2	1	2	5	621111	049	1.3	1.3	1.3	.5	.5	.5	95	95	800	1,000	800	8.8	85			431
2004/1	2	2	5	621111	049	0	0	0	0	0	0	0	0	0	0	0	0				411
2003/4	2	2	5	621111	049	0	0	0	0	0	0	0	0	0	0	0	0				341
2003/3	2	2	5	621111	049	0	0	0	0	0	0	0	0	0	0	0	0				331
2002/2 EDIT CODES/MESSAGES:																					
091-W EMPLOYMENT CHANGE GREATLY EXCEEDS TEST PARAMETERS																					

** CONFIDENTIAL DATA ** FOR STATISTICAL USE BY AUTHORIZED PERSONNEL ONLY. DESTROY ACCORDING TO RECORDS RETENTION SCHEDULE.																					

EXHIBIT 13U

```

DATE: MM/DD/YYYY    TIME: 06:07:08 PM                    (STATE)                    PAGE 1
INITIAL RUN    YYYY/Q                                PREDECESSOR/SUCCESSOR EDIT LISTING - TABLE 9P    ** CONFIDENTIAL DATA **
                                                    BUREAU OF LABOR STATISTICS - EQUI PROCESSING
PREDECESSOR
UI/RUN: 1234567890/00044                                | SUCCESSOR
EIN: 987654321                                | 0003456789/00045
LEGAL NAME: COMPANY CORPORATION                                | 412412412
TRADE NAME: THE COMPANY                                | ACE INCORPORATED
NAICS: 336330 Motor vehicle steering and suspension pa    | AZTEC MERCHANDISE
DATES: LIAB: 1994/04/01 EOL: / / REACT: / /                | 336330 Motor vehicle steering and suspension pa
CURRENT CC: 92                                | LIAB: 2005/01/01 EOL: / / REACT: / /
CURRENT NAR:                                | 92
PRIOR CC:
PRIOR NAR:
ARS: RESPONSE CODE: 98 REFILE YEAR: 2005 AVER: 511        | RESPONSE CODE: 41 REFILE YEAR: 2005 AVER: 512
OLD CODES: CTY: OWN: NAICS:                                | CTY: OWN: NAICS:
|-----2004/4-----|-----2005/1-----|
| S M O | S M O |
| T E W NAICS CTY TWN M1 M2 M3 TOTAL WAGES QVER | T E W NAICS CTY TWN M1 M2 M3 TOTAL WAGES QVER |
PRED | 1 1 5 336330 083 000 501R 499R 499R 5,906,511R 511 | 1 1 5 336330 083 000 357R 361R 358R 3,728,152R 511 |
SUCC | 3 | 0M 0M 0M 0M 000 | 1 1 5 336330 083 000 141R 139R 142R 1,434,158R 512 |
2005/1 EDIT CODES/MESSAGES:
160-W BOTH PREDECESSOR AND SUCCESSOR REPORTED
*****
** CONFIDENTIAL DATA ** FOR STATISTICAL USE BY AUTHORIZED PERSONNEL ONLY. DESTROY ACCORDING TO RECORDS RETENTION SCHEDULE.

```

EXHIBIT 13V

	CURRENT	PRIOR	QTR 3	QTR 4	QTR 5	
	QTR TOT	QTR TOT	TOT	TOT	TOT	
TOTAL RECORDS FAILING SPECIAL CONDITIONS	63	66	0	0	0	
MONTH 3 EMPLOYMENT	12,548	13,559	0	0	0	
TOTAL WAGES	97,878,412	110,351,287	0	0	0	
LARGE RECORDS WITH CNTY 999	63	66	0	0	0	
MONTH 3 EMPLOYMENT	12,548	13,559	0	0	0	
TOTAL WAGES	97,878,412	110,351,287	0	0	0	
LARGE RECORDS WITH NAICS 999999	1	0	0	0	0	
MONTH 3 EMPLOYMENT	108	0	0	0	0	
TOTAL WAGES	286,865	0	0	0	0	
LARGE RECORDS WITH CNTY 995	0	0	0	0	0	
MONTH 3 EMPLOYMENT	0	0	0	0	0	
TOTAL WAGES	0	0	0	0	0	
RECORDS IN DC WITH SECTOR 11	0	0	0	0	0	
MONTH 3 EMPLOYMENT	0	0	0	0	0	
TOTAL WAGES	0	0	0	0	0	
RECORDS IN DC WITH COUNTY 995/999	0	0	0	0	0	
MONTH 3 EMPLOYMENT	0	0	0	0	0	
TOTAL WAGES	0	0	0	0	0	
	EDIT	CURRENT	PRIOR	QTR 3	QTR 4	QTR 5
	CODE	QTR TOT	QTR TOT	TOT	TOT	TOT
TOTAL RECORDS FAILING NAICS PUBLICATION EDITS		0	0	0	0	0
MONTH 3 EMPLOYMENT		0	0	0	0	0
TOTAL WAGES		0	0	0	0	0
RECS W/ INVALID NAICS CODE	010	0	0	0	0	0
MONTH 3 EMPLOYMENT		0	0	0	0	0
TOTAL WAGES		0	0	0	0	0
RECS W/ INVALID OWNERSHIP CODE	012	0	0	0	0	0
MONTH 3 EMPLOYMENT		0	0	0	0	0
TOTAL WAGES		0	0	0	0	0
RECS W/ INVALID COUNTY CODE	013	0	0	0	0	0
MONTH 3 EMPLOYMENT		0	0	0	0	0
TOTAL WAGES		0	0	0	0	0
RECS W/ NAICS & OWNERSHIP INCONSISTENT	016	0	0	0	0	0
MONTH 3 EMPLOYMENT		0	0	0	0	0
TOTAL WAGES		0	0	0	0	0
RECS W/ INVALID STATUS CODE	025	0	0	0	0	0
MONTH 3 EMPLOYMENT		0	0	0	0	0
TOTAL WAGES		0	0	0	0	0
RECS W/ INVALID M1 EMPLOYMENT	031	0	0	0	0	0
MONTH 3 EMPLOYMENT		0	0	0	0	0
TOTAL WAGES		0	0	0	0	0

 ** CONFIDENTIAL DATA ** FOR STATISTICAL USE BY AUTHORIZED PERSONNEL ONLY. DESTROY ACCORDING TO RECORDS RETENTION SCHEDULE.

EXHIBIT 13V (continued)

DATE: MM/DD/YYYY		TIME: 06:07:08 PM		(STATE)		PAGE 2	
INITIAL RUN YYYY/Q		RECORDS FAILING NAICS PUBLICATION STANDARDS		- TABLE 9X		** CONFIDENTIAL DATA **	
BUREAU OF LABOR STATISTICS - EQUI PROCESSING							
EDIT	CURRENT	PRIOR	QTR 3	QTR 4	QTR 5		
CODE	QTR TOT	QTR TOT	TOT	TOT	TOT		
RECS W/ INVALID M2 EMPLOYMENT	032	01	01	01	01	01	01
MONTH 3 EMPLOYMENT		01	01	01	01	01	01
TOTAL WAGES		01	01	01	01	01	01
RECS W/ INVALID M3 EMPLOYMENT	033	01	01	01	01	01	01
MONTH 3 EMPLOYMENT		01	01	01	01	01	01
TOTAL WAGES		01	01	01	01	01	01
RECS W/ INVALID TOTAL WAGES	034	01	01	01	01	01	01
MONTH 3 EMPLOYMENT		01	01	01	01	01	01
TOTAL WAGES		01	01	01	01	01	01
RECS W/ INVALID TAXABLE WAGES	035	01	01	01	01	01	01
MONTH 3 EMPLOYMENT		01	01	01	01	01	01
TOTAL WAGES		01	01	01	01	01	01
RECS W/ INVALID CONTRIBUTIONS	036	01	01	01	01	01	01
MONTH 3 EMPLOYMENT		01	01	01	01	01	01
TOTAL WAGES		01	01	01	01	01	01
RECS W/ INVALID TYPE OF COVERAGE	039	01	01	01	01	01	01
MONTH 3 EMPLOYMENT		01	01	01	01	01	01
TOTAL WAGES		01	01	01	01	01	01
RECS W/ INVALID MEEI	040	01	01	01	01	01	01
MONTH 3 EMPLOYMENT		01	01	01	01	01	01
TOTAL WAGES		01	01	01	01	01	01
RECS W/INCONSISTENT OWNERSHIP/TYPE OF COVERAGE	056	01	01	01	01	01	01
MONTH 3 EMPLOYMENT		01	01	01	01	01	01
TOTAL WAGES		01	01	01	01	01	01
RECS W/ TAXABLE WAGES ON FEDERAL RECORD	057	01	01	01	01	01	01
MONTH 3 EMPLOYMENT		01	01	01	01	01	01
TOTAL WAGES		01	01	01	01	01	01
RECS W/ CONTRIBUTIONS ON FEDERAL RECORD	058	01	01	01	01	01	01
MONTH 3 EMPLOYMENT		01	01	01	01	01	01
TOTAL WAGES		01	01	01	01	01	01
RECS W/ CONTRIB>0 FOR NON-EXP RATED RECORD	060	01	01	01	01	01	01
MONTH 3 EMPLOYMENT		01	01	01	01	01	01
TOTAL WAGES		01	01	01	01	01	01
RECS W/ TAXABLE WAGES > TOTAL WAGES	062	01	01	01	01	01	01
MONTH 3 EMPLOYMENT		01	01	01	01	01	01
TOTAL WAGES		01	01	01	01	01	01
RECS W/ CONTRIBUTIONS > TAXABLE WAGES	063	01	01	01	01	01	01
MONTH 3 EMPLOYMENT		01	01	01	01	01	01
TOTAL WAGES		01	01	01	01	01	01

 ** CONFIDENTIAL DATA ** FOR STATISTICAL USE BY AUTHORIZED PERSONNEL ONLY. DESTROY ACCORDING TO RECORDS RETENTION SCHEDULE.

EXHIBIT 13V (continued)

DATE: MM/DD/YYYY		TIME: 06:07:08 PM		(STATE)		PAGE 3							
INITIAL RUN YYYY/Q		RECORDS FAILING NAICS PUBLICATION STANDARDS		- TABLE 9X		** CONFIDENTIAL DATA **							
BUREAU OF LABOR STATISTICS - EQUI PROCESSING													
UI ACCOUNT/RUN: 1234567890 00044		TRADE: TRAIN FOREST		LEGAL: TRAIN FOREST UNLIMITED									
EIN: 123456789		LIAB: 2000/07/01 EOL: / /		SETUP: 2000/10/01 REACT: / /		ORG: AVER: 511							
PRED: 987654321 00000		SUCC:											
S M C O		A											
YEAR/Q	T E V W	NAICS	X CTY TWN	M1	M2	M3	TOTAL WAGES	AWW	TAX. WAGES	CTB	CC CC CC	EDI	QVER
2005/1	1 4 0 5	561320	5 999 000	1,447	1,500	1,476	5,744,647	300	5,666,466	228,925			511
2004/4	1 4 0 5	561320	5 999 000	1,837	1,703	1,546	6,755,537	307	4,684,745	156,470	05		441
2004/3	1 4 0 5	561320	5 999 000	1,415	1,515	1,593	6,750,921	344	4,973,060	166,100			431
2004/2	1 4 0 5	561320	5 999 000	1,316	1,344	1,469	5,524,118	309	4,786,614	159,873			421
2004/1	1 4 0 5	561320	5 999 000	1,186E	1,423E	1,565E	4,578,579	253	4,497,271	150,209			411
2003/4	1 4 0 5	561320	5 999 000	1,238	1,276	1,223	5,088,836	314	3,364,789	105,654			341
ARS RESPONSE CODE: 41 REFILE YEAR: 2004 OLD CODES:				CNTY:		OWN:		NAICS:		TOWN: 000			

** CONFIDENTIAL DATA ** FOR STATISTICAL USE BY AUTHORIZED PERSONNEL ONLY. DESTROY ACCORDING TO RECORDS RETENTION SCHEDULE.													

EXHIBIT 13W

DATE: MM/DD/YYYY		TIME: 06:33:21 PM		(STATE)		PAGE 1																	
INITIAL RUN YYYY/Q		MULTI-ESTABLISHMENT EDIT LISTING - TABLE 10						**CONFIDENTIAL DATA**															
BUREAU OF LABOR STATISTICS - EQUI PROCESSING																							
UI ACCT: 0987654321		HARBORS TROLLING INC		EIN: 737373737		OWN: 5 P/S: _____		SPEC: _ AGENT: _____		EDI: _ AVER: 512													
-----2004/4----- -----2005/1-----																							
RUN	NAME	S	M	CTY	NAICS	M1	M2	M3	TOTAL WAGES	OVER	S	M	CTY	NAICS	M1	M2	M3	TOTAL WAGES	OVER				
00000		3	0			OM	OM	OM	OM 000		1	1	995	561320	OM	OM	OM		OM	512			
00001	HARBORS	3	0			OM	OM	OM	OM 000		1	3	016	561320	OC	95C	96C	437,571C	511				
00002	HARBORS	3	0			OM	OM	OM	OM 000		1	3	026	621610	OM	112C	111C	510,901C	511				
NO MASTER RECORD																							
SUM OF WORKSITES TALLY:		0		0		0		0		0		TALLY:		2		0		207		207		948,472	
2005/1 EDIT CODES/MESSAGES:																							
179 WORKSITE MISSING MASTER																							
180 SINGLE ACCOUNT/ACTIVE WORKSITES																							
*** END OF MULTI ESTABLISHMENT EDIT LISTING ****																							

EXHIBIT 13X

DATE: MM/DD/YYYY		TIME: 07:07:00 AM		(STATE)		PAGE 1				
INITIAL RUN YYYY/Q				MACRO REVISIONS - TABLE 13A		**CONFIDENTIAL DATA**				
BUREAU OF LABOR STATISTICS - EQUI PROCESSING										
CNTY: <u>015</u>		OWN: <u>2</u>		INDUSTRY CODE: <u>311330</u>						
DATA	NO. OF ESTABL	2004/3 EMPLOYMENT			TOTAL WAGES	NO. OF ESTABL	2004/4 EMPLOYMENT			TOTAL WAGES
		M1	M2	M3			M1	M2	M3	
OLD:	4	4752	4758	4766	48,368,553	4	4723	4729	4737	48,078,342
NEW:	4	4752	4758	4766	48,368,553	4	4454	4490	4746	46,980,716
NET										
DIFF:	+0	+0	+0	+0	+0	+0	-269	-239	+9	-1,097,626
CNTY: <u>017</u>		OWN: <u>5</u>		INDUSTRY CODE: <u>334119</u>						
DATA	NO. OF ESTABL	2004/3 EMPLOYMENT			TOTAL WAGES	NO. OF ESTABL	2004/4 EMPLOYMENT			TOTAL WAGES
		M1	M2	M3			M1	M2	M3	
OLD:	26	77	78	79	696,890	28	136	140	144	9,409,838
NEW:	26	77	78	79	696,890	27	76	80	81	696,927
NET										
DIFF:	+0	+0	+0	+0	+0	-1	-60	-60	-63	-8,712,911
EDIT CODES - REMAINING MACRO CODES AND ERROR LEVEL STATUS:					EDIT CODES - REMAINING MACRO CODES AND ERROR LEVEL STATUS:					
CNTY: <u>019</u>		OWN: <u>5</u>		INDUSTRY CODE: <u>522210</u>						
DATA	NO. OF ESTABL	2004/3 EMPLOYMENT			TOTAL WAGES	NO. OF ESTABL	2004/4 EMPLOYMENT			TOTAL WAGES
		M1	M2	M3			M1	M2	M3	
OLD:	12	1397	1413	1407	15,424,274	13	1548	1547	1546	15,717,833
NEW:	12	1397	1413	1407	15,424,274	12	1407	1403	1406	13,883,917
NET										
DIFF:	+0	+0	+0	+0	+0	-1	-141	-144	-140	-1,833,916
EDIT CODES - REMAINING MACRO CODES AND ERROR LEVEL STATUS:					EDIT CODES - REMAINING MACRO CODES AND ERROR LEVEL STATUS:					
L6										

EXHIBIT 13Y

YEAR/Q	AME	OTQ	OTY	AWW	OTQ	OTY	NO.	M1	M2	M3	TOTAL WAGES
2005/1	777	-14	-11	753	-14	-3	4	888	887	855	25,464,866
2004/4	899	0	-4	875	2	-4	4	910	709	889	15,140,125
2004/3	902	-4	-49	857	-10	-65	4	966	958	902	15,274,259
2004/2	944	8	-41	957	23	-70	5	978	955	899	11,739,554
2004/1	875	-6	43	777	-15	-2	4	916	883	825	8,834,340
2003/4	932	-48	13	912	-63	-2	4	918	932	945	11,040,406
2003/3	1,784	11	1	2,482	-22	13	8	1,762	1,779	1,810	57,553,640
2003/2	1,605	34	-17	3,183	47	4	8	1,589	1,605	1,622	66,430,607

DATE: MM/DD/YYYY TIME: 08:08:08 AM (STATE NAME) PAGE 1
 INITIAL RUN YYYY/Q MACRO REVISIONS FAILING EDITS - TABLE 13B **CONFIDENTIAL DATA**
 BUREAU OF LABOR STATISTICS - EQUI PROCESSING

OWNERSHIP: 5 COUNTY: 020 ANCHORAGE NAICS: 611310 Colleges and universities

2005/1 MACRO EDIT CODES/MESSAGES:
 126-W EMPLOYMENT CHANGE EXCEEDS TEST PARAMETERS

2004/2 MACRO EDIT CODES/MESSAGES:
 126-W EMPLOYMENT CHANGE EXCEEDS TEST PARAMETERS

SUMMARY OF DIFFERENCES		2004/4		2005/1		TOTAL WAGES	
CHANGE TO:	DEC. EMPL.	NO. ESTAB.	JAN EMPL.	FEB EMPL.	MAR EMPL.	TOTAL WAGES	TOTAL WAGES
CHANGE FROM:	407	1	288	326	339	6,900,763	6,900,763
NET DIFFERENCE:	0	0	0	0	0	0	0
	407	1	288	326	339	6,900,763	6,900,763

QVER: 511

DIFFERENCE	NO. OF ESTABL	EMPLOYMENT			TOTAL WAGES
		M1	M2	M3	
2004/1	+0	-116	-127	-36	-3,447,234

UI ACCOUNT/RUN: 5567890123 00044 TRADE: HELIOBACTOR PILORI PRED: SUCC:

YEAR/Q	S M O	T E W EDI	NAICS	CTY	LEV	OTQ	OTY	LEV	OTQ	OTY	M1	M2	M3	TOTAL WAGES	CC	CC	CC	
2005/1	1	3	5	611310	020	8	3	2	460	-70	-194	7R	9R	9R	49,805R			
2004/4	1	3	5	611310	020	5	1	-1	530	90	146	3R	5R	6R	32,168R			
2004/3	1	3	5	611310	020	4	-1	-1	440	-19	102	5R	4R	3R	22,871R			
2004/2	1	3	5	611310	020	5	-1	5	459	-195	459	5D	5D	5D	29,853R			
2004/1	1	3	5	611310	020	6	0	6	654	270	654	6E	6E	6E	51,008R			

EXHIBIT 13Y (continued)

DATE: MM/DD/YYYY		TIME: 08:08:08 AM		(STATE NAME)										PAGE 2								
INITIAL RUN YYYY/Q		MACRO REVISIONS FAILING EDITS - TABLE 13B										**CONFIDENTIAL DATA**										
BUREAU OF LABOR STATISTICS - EQUI PROCESSING																						

UI ACCOUNT/RUN: 4567890123 00044				TRADE:				PRED:				SUCC: 1970/01/06										
YEAR/Q	S	M	O	T	E	W	EDI	NAICS	CTY	LEV	OTQ	OTY	LEV	OTQ	OTY	M1	M2	M3	TOTAL WAGES	CC	CC	CC
2005/1	1	3	5					611310	020	877	5	5	2,234	60	186	888	887	855	25,464,866			31
2004/4	1	3	5					611310	020	836	-11	-7	1,393	12	-55	910E	709E	889E	15,140,125E			
2004/3	1	3	5					611310	020	942	4	82	1,247	29	39	966	958	902	15,274,259			
2004/2	1	3	5					611310	020	909	8	-484	966	24	-4304	943	920	863	11,407,193		05	31
2004/1	1	3	5					611310	020	839	-6	-446	782	-15	-2585	880	845	791	8,521,631			
2005/1 EDIT CODES/MESSAGES:																						
092-W AQW CHANGE IS SIGNIFICANTLY > PARM AND EXCEEDS TWICE THE QUARTILE AQW RANGE																						

UI ACCOUNT/RUN: 0123456789 00022				TRADE:				PRED:				SUCC: 1970/01/06										
YEAR/Q	S	M	O	T	E	W	EDI	NAICS	CTY	LEV	OTQ	OTY	LEV	OTQ	OTY	M1	M2	M3	TOTAL WAGES	CC	CC	CC
2005/1	1	3	5					611310	020	877	5	5	2,234	60	186	888	887	855	25,464,866			31
2004/4	1	3	5					611310	020	836	-11	-7	1,393	12	-55	910E	709E	889E	15,140,125E			
2004/3	1	3	5					611310	020	942	4	82	1,247	29	39	966	958	902	15,274,259			
2004/2	1	3	5					611310	020	909	8	-484	966	24	-4304	943	920	863	11,407,193		05	31
2004/1	1	3	5					611310	020	839	-6	-446	782	-15	-2585	880	845	791	8,521,631			
2005/1 EDIT CODES/MESSAGES:																						
092-W AQW CHANGE IS SIGNIFICANTLY > PARM AND EXCEEDS TWICE THE QUARTILE AQW RANGE																						
*****														***** END OF MACRO REVISIONS FAILING EDITS REPORT *****								

EXHIBIT 13Z

DATE: MM/DD/YYYY	TIME: 06:07:08 PM	(STATE)	PAGE	1
INITIAL RUN	YYYY/Q	COMMENT CODES AND NARRATIVE COMMENTS - TABLE 15	BUREAU OF LABOR STATISTICS - EQUI PROCESSING	
COUNT	CODE	DESCRIPTION.		
0	00	MULTIPLE WORKSITES TO SINGLE (QCEW).		
1,899	01-19	EMPLOYMENT SHIFTS.		
22	01	SEASONAL INCREASE.		
65	02	SEASONAL DECREASE.		
236	03	MORE BUSINESS (EXPANSION).		
231	04	LESS BUSINESS (CONTRACTION).		
45	05	SHORT-TERM/SPECIFIC BUSINESS PROJECT STARTING OR CONTINUING.		
30	06	SHORT-TERM/SPECIFIC BUSINESS PROJECT COMPLETED OR APPROACHING COMPLETION.		
6	07	LAYOFF, NOT ELSEWHERE CLASSIFIED.		
29	09	TEMPORARY SHUTDOWN		
3	10	CONVERSION OR REMODEL OF FACILITIES, RETOOLING, OR REPAIR & MAINTENANCE OF EQUIPMENT RESULTING IN EMPL. DECREASE.		
1	11	CONVERSION OR REMODEL OF FACILITIES, RETOOLING, OR REPAIR & MAINTENANCE OF EQUIPMENT RESULTING IN EMPL. INCREASE.		
48	12	INTERNAL REORGANIZATION, DOWNSIZING OR BANKRUPTCY RESULTING IN AN EMPLOYMENT DECREASE.		
12	13	INTERNAL REORGANIZATION, DOWNSIZING OR BANKRUPTCY RESULTING IN AN EMPLOYMENT INCREASE.		
1	14	NONSTANDARD WORK SCHEDULE.		
43	15	INTRA-ACCOUNT (FIRM) TRANSFERS.		
1,100	18	ACTIVE EMPLOYER REPORTING ZERO EMPLOYMENT AND WAGES.		
27	19	EMPLOYMENT RETURNS OR RETURNING TO NORMAL OR A NEWNORMAL AFTER CODED 07-18.		
919	20-36	PAY SHIFTS.		
13	20	WAGE RATE DECREASE.		
8	21	WAGE RATE INCREASE (INCLUDING COLAS).		
97	22	INCREASE IN PERCENTAGE OF LOWER-PAID EMPLOYEES.		
24	23	INCREASE IN PERCENTAGE OF HIGHER-PAID EMPLOYEES.		
2	24	LOWER HOURLY EARNINGS OR WAGES BECAUSE OF PIECEWORK OR LOWER INCENTIVE PAY.		
13	29	SEVERENCE PAY DISTRIBUTED.		
5	30	WAGES PAID TO EMPLOYEES WORKING IN PAY PERIODS NOT INCLUDING THE 12 OF THE MONTH AND NOT SHOWN IN EMPLOYMENT.		
370	31	BONUSES, EXECUTIVE PAY, PROFITS DISTRIBUTED LUMP-SUM PAYMENTS.		
1	32	CHANGE IN COMMISSIONS.		
1	34	CHANGE IN HOURLY EARNINGS OR PAY DUE TO CHANGE IN AMOUNT OF SHIFT WORK WITH PAY DIFFERENTIAL.		
4	35	CHANGES IN HOURS, EARNINGS, OR WAGES DUE TO LEGISLATION/ADMINISTRATIVE REGULATIONS.		
381	36	PAY RETURNS OR RETURNING TO NORMAL OR A NEW NORMAL AFTER CODED 29-35.		
1	39	LABOR SHORTAGE.		
1	39	DECREASE IN EMPLOYMENT RESULTING FROM A LABOR SORTAGE.		
5	40-47, 49	HOURS, TIME AND VACATION.		
1	40	SHORTER SCHEDULED WORKWEEK; FEWER HOURS WORKED; NUMBER OF PAY PERIODS LESS THAN USUAL.		
4	43	INCREASE IN PART-TIME WORKERS.		
3	48	IMPROVED REPORTING (QCEW).		
3	48	IMPROVED REPORTING (QCEW).		

EXHIBIT 13Z (continued)

DATE: MM/DD/YYYY	TIME: 06:07:08 PM	(STATE)	PAGE	2
INITIAL RUN	YYYY/Q	COMMENT CODES AND NARRATIVE COMMENTS - TABLE 15 BUREAU OF LABOR STATISTICS - EQUI PROCESSING		
COUNT	CODE	DESCRIPTION.		
0	50-55	EXTERNAL FACTORS.		
0	58	ENVIRONMENTAL LEGISLATION.		
0	59-60	DEFENSE-RELATED CODES.		
0	61-64	TEMPORARY USE CODES (CES/QCEW).		
0	65-74	STATE-SPECIFIC CODES (CES USE ONLY).		
0	75-79	TAX OR COVERAGE CHANGES (QCEW USE ONLY).		
484	80-82	CODING AND CLASSIFICATION CHANGES.		
478	81	NONECONOMIC CODE CHANGE.		
6	82	ECONOMIC CODE CHANGE.		
2,978	83-93	REPORTING ISSUES.		
185	83	EMPLOYEE LEASING REPORTING CHANGE.		
588	85	NEW ESTABLISHMENT OR WORKSITE.		
297	86	ESTABLISHMENT PERMANENTLY OUT OF BUSINESS.		
46	87	REACTIVATED UI ACCOUNT OR WORKSITE (QCEW).		
1	88	ESTABLISHMENT DISSOLUTION.		
9	89	ESTABLISHMENT MERGER.		
737	90	CHANGED BASIS OF, REPORTING WITH MORE DETAIL.		
19	91	CHANGED BASIS OF REPORTING WITH LESS DETAIL.		
90	92	PARTIAL PREDECESSOR/SUCCESSOR TRANSACTION (QCEW) /CES CANCELLATION (CES).		
1,006	93	FULL PREDECESSOR/SUCCESSOR TRANSFER (QCEW).		
76	94-99	VERIFICATION.		
4	98	DATA VERIFIED BY EDIC(QCEW) ./DATA VERIFIED BY REGIONAL OFFICE(CES).		
72	99	DATA VERIFIED--SEE NARRATIVE.		
96	--	NARRATIVE COMMENTS.		

EXHIBIT 13Z (continued)

DATE: MM/DD/YYYY	TIME: 06:49:22 PM	(STATE)	PAGE	3
INITIAL RUN	YYYY/Q	COMMENT CODES AND NARRATIVE COMMENTS - TABLE 15 BUREAU OF LABOR STATISTICS - EQUI PROCESSING		
COUNT	PERCENT*	RECORDS WITH COMMENTS.		
6,365	6.76%	TOTAL COMMENTS, IN ALL RECORDS.		
5,049	5.36%	TOTAL RECORDS WITH COMMENTS.		
4,005	4.25%	RECORDS WITH EXACTLY ONE COMMENT CODE.		
772	0.82%	RECORDS WITH EXACTLY TWO COMMENT CODES.		
272	0.28%	RECORDS WITH EXACTLY THREE COMMENT CODES.		
96	0.10%	RECORDS WITH NARRATIVE COMMENT AND AT LEAST ONE COMMENT CODE.		
COUNT	PERCENT**	COMMENTS WITHIN EACH OWNERSHIP.		
39	0.77%	FEDERAL GOVERNMENT	RECORDS WITH COMMENTS.	
18	0.35%	STATE GOVERNMENT	RECORDS WITH COMMENTS.	
159	3.14%	LOCAL GOVERNMENT	RECORDS WITH COMMENTS.	
4,833	95.72%	PRIVATE SECTOR	RECORDS WITH COMMENTS.	
COUNT	PERCENT**	RECORDS WITH COMMENTS AND EDIT FLAGS.		
371	7.34%	RECORDS WITH LEVELS 5-8 EDIT FLAGS WITH COMMENTS.		
79	1.56%	RECORDS WITH LEVEL 5 EDIT FLAGS WITH COMMENTS.		
280	5.54%	RECORDS WITH LEVEL 6 EDIT FLAGS WITH COMMENTS.		
0	0.00%	RECORDS WITH LEVEL 7 EDIT FLAGS WITH COMMENTS.		
18	0.35%	RECORDS WITH LEVEL 8 EDIT FLAGS WITH COMMENTS.		
COUNT	PERCENT**	COMMENTS WITHIN EACH MEEI CODE.		
2,487	49.25%	MEEI = 1 RECORDS WITH COMMENTS.		
2,527	50.04%	MEEI = 3 RECORDS WITH COMMENTS.		
29	0.57%	MEEI = 4 RECORDS WITH COMMENTS.		
2	0.03%	MEEI = 5 RECORDS WITH COMMENTS.		
4	0.07%	MEEI = 6 RECORDS WITH COMMENTS.		
COUNT	PERCENT**	COMMENTS WITHIN EACH DATA SOURCE.		
249	4.93%	EDI RECORDS WITH COMMENTS.		
* PERCENTAGES ARE BASED ON THE TOTAL NUMBER OF ACTIVE RECORDS (EXCLUDING MASTERS).				
** PERCENTAGES ARE BASED ON THE NUMBER OF ACTIVE RECORDS WITH AT LEAST ONE COMMENT CODE (EXCLUDING MASTERS). THE END OF THE COMMENT CODES AND NARRATIVE COMMENTS LISTING.				

EXHIBIT 13AA

DATE: MM/DD/YYYY	TIME: 07:07:00 AM	(STATE)	PAGE 1																
INITIAL RUN	YYYY/Q	EQUI SAMPLE RECORDS - TABLE 16	**CONFIDENTIAL DATA**																
BUREAU OF LABOR STATISTICS - EQUI PROCESSING																			

YEAR/Q	ST	UI ACCOUNT	RUN	EI NO.	STAT	MEEI	COV	EDI	CES	SP AGENT	RCI	OWN	ORG	CNTY	TOWN	NAICS	AUX	SIC	NSTA
2005/1	66	4567890123	00044	567890123	1	1	0		C		0	5	C	009	000	424450	5	5145	
REFILING YEAR:		2001	RESP CODE: 41				OLD CODE:5		009	000	422450	5145							
M1 EMPL:		00000325R	M2 EMPL: 00000327R		M3 EMPL: 00000324R		TW: 000000000172411R		TAXW:00000000122411		CONTR: 00000000979								
COMMENTS:		NARRATIVE:																	
TRADE NAME		CITY OF BUBBLE SPRINGS																	
LEGAL NAME																			
		PHONE NUMBER 444-555-3333																	
		----- PHYSICAL ----- UI ----- MAILING/OTHER -----																	
ADDRESS		20 MILKY WAY																	
ADDRESS2																			
CITY		BUBBLE SPRINGS																	
STATE ZIP		UA 23456-																	
RU DESCR																			
PREDECESSOR UI#/RUN:		INITIAL LIABILITY DATE: 1950/04/01										REACT DATE:		/ /					
SUCCESSOR UI#/RUN:		SETUP DATE: 1950/04/01										END OF LIAB DATE:		/ / REC# 29					

YEAR/Q	ST	UI ACCOUNT	RUN	EI NO.	STAT	MEEI	COV	EDI	CES	SP AGENT	RCI	OWN	ORG	CNTY	TOWN	NAICS	AUX	SIC	NSTA
2005/1	66	1234567890	00005	345678901	1	1	0		C		0	5	C	011	000	323110	5	2752	
REFILING YEAR:		1999	RESP CODE: 46				OLD CODE:5		011	000	2759								
M1 EMPL:		00000036R	M2 EMPL: 00000046R		M3 EMPL: 00000055R		TW: 000000000048120R		TAXW:00000000033120		CONTR: 00000000861								
COMMENTS:		NARRATIVE:																	
TRADE NAME		OLD HOUSE REALTY CORP																	
LEGAL NAME		OLD HOUSE REALTY CORP																	
		PHONE NUMBER 987-654-3210																	
		----- PHYSICAL ----- UI ----- MAILING/OTHER -----																	
ADDRESS		721 W. QUENSTON HIGHWAY																	
ADDRESS2																			
CITY		GOULD																	
STATE ZIP		UA 77333																	
RU DESCR																			
PREDECESSOR UI#/RUN:		INITIAL LIABILITY DATE: 1953/10/01										REACT DATE:		/ /					
SUCCESSOR UI#/RUN:		SETUP DATE: 1953/10/01										END OF LIAB DATE:		/ / REC# 58					

YEAR/Q	ST	UI ACCOUNT	RUN	EI NO.	STAT	MEEI	COV	EDI	CES	SP AGENT	RCI	OWN	ORG	CNTY	TOWN	NAICS	AUX	SIC	NSTA
2005/1	66	7890123456	00018	123456789	1	1	0				0	5	C	011	000	425120	5	5192	
REFILING YEAR:		2001	RESP CODE: 41				OLD CODE:5		011	000	422920	5192							
M1 EMPL:		00000011R	M2 EMPL: 00000011R		M3 EMPL: 00000011R		TW: 000000000038451R		TAXW:00000000010096		CONTR: 00000000071								
COMMENTS:		NARRATIVE:																	
TRADE NAME		PAYMORE FOR LESS INC																	
LEGAL NAME		PAYMORE FOR LESS INC																	
		PHONE NUMBER 123-456-7890																	
		----- PHYSICAL ----- UI ----- MAILING/OTHER -----																	
ADDRESS		1776 BROADWAY																	
ADDRESS2																			
CITY		EL WACKO																	
STATE ZIP		UA 12345																	
RU DESCR																			
PREDECESSOR UI#/RUN:		INITIAL LIABILITY DATE: 1955/01/01										REACT DATE:		/ /					
SUCCESSOR UI#/RUN:		SETUP DATE: 1955/01/01										END OF LIAB DATE:		/ / REC# 87					

MEEI	Valid County/Valid Township Combination
1-6	999/999
1-6	995/995
1-6	996/996
1-6	998/998
2	any county code including 900, 995, 996, 998; and township 900 or 999

Chapter 14 – Documenting and Validating State Operations

BLS routinely monitors state performance and develops plans to share best practices, promote improvements, and address deficiencies with the ultimate goal of assessing and improving QCEW program data quality. This chapter outlines the formal aspects of this monitoring and explains the tools used for review and documentation purposes. The BLS Large Multi-Unit ARS Review, also known as the “central review” is discussed in Chapter 6, Annual Refile Survey.

In addition to internal BLS validation, feedback and information requests are also provided to states stemming from BLS’ relationships with other federal statistical agencies or private partnerships provided under memorandum of understanding (MOU). The process and details of what information may be shared and how this may impact the data is specified in those MOU’s.

----- Contents of Chapter 14 -----

- 14.1 Quarterly Monitoring
- 14.2 Annual Report
- 14.3 State Operations Review
- 14.4 NAICS Quality Review
- 14.5 Large Code Change Review

14.1 Quarterly Monitoring

Each quarter regional office staff monitor state processing schedules prior to the EQUI submittal due date and conduct a review of summary processing statistics to identify and resolve systematic data quality problems prior to submittal of the initial file.

It is a best practice for states to provide to their regional office with detailed processing schedules. If done, it should be provided at least once a year. The processing schedules provide detailed information on the timing of each task related to creating the EQUI deliverable. Regional offices can review the processing schedules to ensure that identified best practices are followed in the states. Best practice processing schedules will include detailed plans including the timing of each task related to EQUI submittal, which jobs are run, timing and number of UI extracts, and any other pertinent details. Appendix E provides an example processing schedule.

State systems have two reports that can be generated on demand by states to provide useful information to both state QCEW supervisors and regional office staff. One is called the QCEW/CES Comparison Sheet and the other is called the Flash Report in Expo(DCount Report in Win.) The QCEW/CES Comparison Sheet is required in the cooperative agreement. Sharing the Flash/Dcount Report with BLS is not required by the cooperative agreement but is a best practice.

States and regions can compare summary counts against similar data from previous EQUI reports to highlight areas that need to be reviewed. It is recommended that states send a Flash/Dcount Report and QCEW/CES Comparison Sheet to the regional office 2 weeks prior to the creation of the EQUI file. These reports contain summaries only, they have no confidential data, and so can be e-mailed by states to regional office staff.

Flash Report/ DCount Report

- a. **State Flash report mechanics:** For EXPO States, States submit Job 29D. For ease in reading this document, use the Excel spreadsheet created to load in this job and compare its output to previous submittals.
- b. **State DCount report mechanics:** For WIN States, States email two files: Dcounts and Summary. Both of these can be loaded similarly to different spreadsheets for comparison purposes. Dcounts counts certain data elements (similar to EXPO's 29D) and Summary provides the number of errors by error codes.

Why the report matters: The flash report can provide clues to potential major data issues such as the amount of imputed and estimated data, large shifts in employment and wage data compared to earlier quarters, and I errors. It is also possible to identify the number of firms with an MEEI 4 to potentially break out, the number of unclassified records with NAICS 999999, County Code 995 and 999 for checking unclassified levels, and the number of new records. This

is a best practice because it has repeatedly led to the discovery and correction of systematic errors before submittal of the primary deliverable.

QCEW/CES Comparison Sheet

- a. **QCEW/CES report mechanics:** documentation on the CES/QCEW roll-up spreadsheet is available on StateWeb
<http://199.221.111.170/program/ES202/GeneralProgramInfo.htm>
- b. **Why the report matters:** The CES/QCEW graphs can be used to compare data at various levels from 3-digit to 6-digit NAICS. They are helpful in spotting data fluctuations that could indicate important issues with EQUI data before the deliverable is submitted. There are also graphs comparing QCEW data to prior year QCEW data, total wages, average weekly wages, and percentage changes in Average Monthly Employment, Total Wages, and Average Weekly Wages. In other words, these spreadsheets detail the data flow between different ownership/NAICS combinations, and compare the data flow from the current year with the data flow from last year. All data are at the State-wide level.

Editing State Data

The QCEW/CES Comparison Sheet compares QCEW and CES trends. Usually these trends are broadly in agreement. When there are large differences in trends, it can be evidence of an upcoming significant state CES benchmark revision. It can also guide QCEW reviewers to substantial errors in QCEW microdata. If QCEW looks reasonable, let CES staff know that they may need to prepare for a substantial revision.

NOTE: CES data should not be used in place of QCEW data, nor should it be used to wedge or otherwise modify QCEW microdata. Validation of QCEW data should be done independently.

14.2 Annual Report

Each year, regional office staff members prepare and submit a report summarizing the state of program operations for each state in their region. The report is typically due to the national office by the end of October, and it includes a systematic annual review of QCEW management information that is presented by category. The report may include information on the state QCEW staffing patterns, any processing or data problems the state is experiencing and the plans for correcting them, a link to a document outlining future system changes planned, and a number of data quality indicators. A full listing of the items to be included in the Annual Report can be found in R-memorandum 19-01.

These performance indicators are updated twice each quarter and available for states and regions to review anytime on StateWeb within the QCEW Program Management Information section. The Historical Data Counts section contains graphs and tables for easy data viewing. The yearly Cooperative Agreement sets the acceptable threshold for employment percentages of NAICS 999999 and county 995/999. A copy of the most recent agreement is available on StateWeb in the LMI section.

14.3 State Operations Review

Purpose

The purpose of an SOR is the following:

- Identify “best practices” that may benefit other States and/or BLS.
- Provide State and BLS staff with a comprehensive summary of State UI Tax Unit practices which impact QCEW.
- Provide State and BLS staff with a comprehensive summary of State QCEW operations and procedures.
- Assist States in determining the staffing needed to support QCEW activities.
- Serve as a record of State operations.
- Help new State and BLS staff become familiar with individual State operations.

Description of the State Operations Review Questionnaire

The SOR consists of a detailed questionnaire administered by the regional office to each state. The SOR is comprised of two parts, called modules. Module 1, UI Tax Database and Procedures, and Module 2, QCEW state operations. Module 1 documents the data types collected by state UI tax departments. The module also documents the lifecycle of UI accounts; the creation of a new establishment, changes in status and ownership, delinquency, closures, reactivation, and quarterly wage and employment reporting. In addition, information on the UI Department leadership roles and responsibilities is documented.

Module 2 provides a picture of LMI/QCEW operations in each State including the extract logic, data elements, and procedures. Procedures for processing non-UI tax data such as multiple worksite reports and the annual refiling survey are also included in the document. Staffing patterns and roles and responsibilities of the QCEW unit are documented.

14.4 NAICS Quality Review

A NAICS quality review is conducted for each state approximately every five years. Regional office staff review a sample of assigned NAICS codes. These reviews are typically conducted after a state has completed the SOR, but the review can also be conducted whenever there is a need. Ideal times within the year for a NAICS quality review are following an EQUI clean-up period such as in late February/March, late May/June, or late August/ September. This is a recommended practice.

Purpose

The purpose of a NAICS quality review is to assess the quality of the NAICS codes assigned by States during the Annual Refiling Survey (ARS) as well as from new employer accounts from the State Status Determination Forms (SDFs).

Review Structure and Design

Reviews may be conducted during an on-site visit, but they are often conducted remotely with teleconference capabilities employed to facilitate discussion. Typically the reviews include one regional office staff member from the host region, one regional office staff member from another region, and one national office coder. The reviewers discuss their findings with state staff. Codes are reviewed by each coder independently, and codes are adjudicated among the team.

This review emphasizes the detection of broad problem areas, rather than error rates for each state or individuals within the state. The spirit of this activity is educational, not disciplinary. The NAICS Quality Assurance review is also an opportunity to provide training to BLS and state staff on NAICS coding procedures. Regional staff identify and note “best practices” so that they can be shared with all states and regions.

14.5 Large Code Change Review

The Large Code Change Review assesses the quality of changes made by states to NAICS and county/township codes of large reporting units during the Annual Refiling Survey. The Large Code Change Review typically begins in April or May and lasts through the first quarter EQUI submittal. Regional offices typically use the CCS edit tables 1a and 1b to identify those establishments that meet the threshold for review.

Results of the Large Code Change Review are included on the Annual Report and document information on the number of cases reviewed, the number of changes recommended and whether or not those recommendations were incorporated by the state. In addition, any trends or consistent coding discrepancies, and recommendations for state NAICS training or other improvement plans are included on the Annual Report.

Chapter 15 – Recurring Coverage and Reporting Problems

The sections in this chapter outline general procedures for identifying and resolving questionable employment counts or total wages reflected in the state system and the EQUI. These guidelines should be followed when a state does not have a relevant UI law.

The following definitions give the basic guidelines for reporting employment and wage data in the QCEW program. This chapter covers reporting practices and special situations that challenge these guidelines; however, basic guidelines should still be applied to the extent possible.

Monthly employment is the total count of all covered full- and part-time employees who worked during, or received pay for, the pay period that includes the 12th day of the month. The count should be unduplicated, so that for the reference period in any month, an employee should be counted only once. **Covered employees** are those workers who are subject to state Unemployment Insurance (UI) laws or the Unemployment Compensation for Federal Employee (UCFE) program. For additional details on who is a covered employee and who is not, please see Chapter 1, section 8 (1.8) of this manual.

For employers providing Multiple Worksite Report (MWR) data, the employee should be counted at only one worksite during each referenced payroll period. Employees that work at more than one site during a referenced payroll period should be reported where they worked the most during that payroll period. Since some payroll systems do not store employment counts for each pay period during the quarter, state QCEW staff should use their judgment as to where the employee may be reported working at the end of the quarter. This assumes that the employee is still working in that state and under the same Unemployment Insurance Account Number.

Total Quarterly Wages (sometimes called “gross wages” or simply “wages”) are the amount of wages paid or payable (depending on the state law) to covered workers for services performed, on all the payrolls of whatever type, during the quarter. Bonuses paid are included in the payroll figures. Also included, when furnished with the job, is the cash value of such items as meals, lodging, tips, and other gratuities, to the extent that state laws and regulations provide. Total wages include both taxable wages and nontaxable wages and are reported by both taxable and reimbursing subject employers.

----- Contents of Chapter 15 -----

- 15.1 Common Employment Reporting Errors
- 15.2 Atypical Payments to Employees
- 15.3 Problem Industries
- 15.4 Related S-Memos

15.1 Common Employment Reporting Errors

End-of Quarter Count

Some employers may mistakenly provide a count of employment as of the time the Quarterly Contribution Report (QCR) is received – possibly the payroll period at the end of the third month of the quarter or the beginning of the following month. This is not generally the proper reference period and, as a result, the employment level reported for that month is somewhat inaccurate. Even more serious, employment for the first two months may be reported as the same figure or even "guesstimated." Thus, data for the first two months of the quarter may be even more inaccurate. This reporting situation may be the most difficult to identify. Identical monthly employment counts and knowledge of the industry by state staff may be the best means of determining that a problem exists.

While identical monthly employment may be accurate for establishments with a small workforce, it is suspect when employment is large. Edit 128-W assigns a warning flag to records with identical monthly employment when the employment exceeds a parameter.

Wage Record Count

The wage record count may be a more common problem, probably because this count is also required by many states to be reported on the QCR. In what are called "wage reporting" states, employers are required to report "wage items" or "wage records." This report is a listing by Social Security Number of all persons receiving pay during the quarter along with their total wages. Typically, the data are reported along with a count of the number of records (persons). Some employers mistakenly believe that this wage record count is also the employment count requested for the payroll period including the twelfth. They then report that same value for each month on the QCR.

Only in an extreme case where the employment level is absolutely constant for the entire quarter is the wage record count equal to the employment count for each of the three reference periods. If there is any turnover or change in staffing, the wage record count will overstate the true employment level for each reference period. The greater the degree of turnover or staffing changes, the larger the overstatement. Again, knowledge of the industry by State staff may be the best means of determining whether a problem exists.

Count of Checks (Payments) Issued

Some employers measure and report employment by counting the number of checks written within the payroll system for a particular period. This approach provides an accurate employment count only if the payroll system limits a person to one check per payroll period for

all types of wage payments combined. Otherwise, the employment count is overstated to the degree that employees receive more than one check during the reference period. Possible types of additional payments include bonuses, commissions, overtime pay, vacation pay, sick pay, holiday pay, moving expenses, severance pay, and contributions to an employee savings plan (e.g., 401(k)). Ensuring that a Social Security Number is counted no more than one time for the appropriate reference period may facilitate generating a proper count.

It should also be noted that using the check date does not guarantee reporting for the proper reference period. The reference payroll period is the payroll period for which – not in which – the employee is being paid. If an employer pays with a time lag, a check for work in the reference period will typically be dated in a later payroll period.

Cumulative Employment Counts

Some employers mistakenly provide cumulative counts of everyone who has worked for them since the beginning of some time period. That period might be a calendar quarter, calendar year, tax year, fiscal year, or another time frame. The resulting pattern of data reported shows employment for each month at or above the level of the preceding month. When the employer's file is purged, as it is periodically, a precipitous decline in reported employment results. Thus, employment is overstated by an amount that grows each month until the overstatement becomes substantial (again, the degree depends on worker turnover). Then a sizable drop in reported employment appears, but it is due to an administrative practice, rather than any economic phenomenon.

One practice that causes this type of overstatement of employment to occur is when an employer reports the number of "active employees" each month. Again, if the employer's active file is not updated every pay period to reflect turnover, an overstatement of monthly employment will result until the file is subsequently purged. Frequently this purge will occur at the start of every quarter, so while it is NOT always the case, one will usually find M1 employment to be much smaller than it is for M3 in the current quarter as well as M3 in prior quarters as well. A pattern of M1 perpetually being smaller than M2 and M3, both current and in prior quarters, may also be evident.

Count of Available Employees

This count is provided typically by employers who maintain a file or list of employees who may be called upon to work. The count reported is the number of people on that list, rather than those who actually worked. Employment is overstated because the count adds those who were potentially available but did not actually work during the relevant period to those who did work. This situation is most likely to occur in industries such as education, retail sales, and temporary help. In these industries, employers frequently maintain lists of certified substitute teachers, contingent sales staff, and available temporaries.

Non-covered Employment

Workers not covered under State UI and UCFE laws should not be counted in QCEW monthly employment or total wage figures. The employment counts and wages reported on the States' Quarterly Contribution Reports should include only those employees who are covered by UI and UCFE. With relatively few exceptions, which may vary from state to state, UI coverage is comprehensive throughout the United States. For more detailed information regarding each state's UI coverage, refer to [Comparison of State Unemployment Insurance Laws](#), published by the Employment and Training Administration (ETA).

The following are notable limitations and exclusions of UI and UCFE coverage:

- Railroad workers covered by the Railroad Unemployment Insurance Act
- State and local government elected officials
- College and university students, spouses of students, student nurses, and interns who work for the institution that they, or their spouse, attend. NOTE: This case is if they are paid through nonmonetary compensation (such as tuition waivers or free room and board or the work is part of a curricular requirement) OR they are NOT paid a wage above UI thresholds.)
- Nonprofit organizations with fewer than 4 employees
- Insurance and real estate agents compensated only by commissions

Handling Reporting Errors

If the state staff determine that the employer is providing incorrect employment counts (for example, those described earlier in this section or some other problem not mentioned), the state staff should ask the employer for additional information under certain conditions. If the incorrect employment level provided by the employer was greater than 50 (note that this is the level reported, not the magnitude of the error), then the state staff should follow the procedures listed below.

- 1) Ask the employer if they use the services of a payroll service bureau, Certified Public Accountant (CPA), bookkeeper, or some other agent, to prepare their QCR. If no, skip to step 2 below. If yes, please obtain the name of the firm, address, phone number, and the name of a contact at that firm from the employer. Also obtain from the employer, the specific year and quarter that the firm started providing this service. The next step would be to contact the firm providing the QCR preparation service and ask how the employment counts are developed. Next, skip to step 4 for more instructions.
- 2) Ask the employer if the employment counts from the QCR are derived from reports prepared by their own staff using payroll/tax filing software that was developed by their own staff (a.k.a. as an in-house payroll/tax system). If no, skip to line 3 below. If yes, ask the employer when (year and quarter) the system was first used and then determine how the employment counts are developed. Then skip to step 4 for more instructions.

- 3) Ask the employer if their software was purchased from a software vendor for use on a personal computer, mainframe computer, client server, or some other computer system. Assuming that the answer to the question is yes, please obtain the name of the firm, address, phone number, and the name of a contact at that firm from the employer. Also determine when (year and quarter) the employer began using that software and how the employment counts are derived. If the employer answered no to this question, please repeat the questions in steps 1 and 2 again as one of these three situations should be applicable.
- 4) With the information that was collected in either steps 1, 2, or 3, the state staff needs to assess the impact of this problem on data for this employer and possibly other employers and states as well. Please contact the appropriate regional office for assistance in resolving this issue if any of the following apply: 1) the employer is large and the difference between the reported values and the correct values are significant, 2) the reported/correct value differences extend over more than two quarters, or 3) the software that was used to produce the employment counts was also used by other employers (either from a service bureau or similar type agent or was purchased from a vendor). If none of the factors just cited were applicable, then correct the current quarter's employment counts. When in doubt, the state staff should consult the appropriate regional office for assistance.

When dealing with this type of problem, it is important to remember that the implementation of a change in the method to compute the employment counts needs to be fully documented. The differences in the method of reporting need to be distinguished from real changes in employment. In the event that a service bureau or software vendor needs to change their method to compute the employment counts, the national office would request that the employment counts be prepared for a minimum of one quarter (preferably two quarters) under both methods to quantify the differences in the counts. In addition, the new methodology would not be introduced in the first or second quarters of the year as these changes would adversely impact the development of the annual employment benchmarks for the Current Employment Statistics program.

15.2 Atypical Payments to Employees

These guidelines should be followed when a state does not have a relevant UI law to address the situation.

Back Wages

Occasionally a firm will pay employees or former employees' back wages, usually as a result of litigation that requires the employer to compensate an employee or group of employees. The back wages awarded may sometimes be for pay periods many years in the past.

Back wage payments should be included in the total wages reported for the reference quarter in which the back wage payment was made. Recipients of the back wages should be included in

the employment figures only if they were actively employed during the reference pay periods of the quarter. If they receive both regular and back pay they should still be counted only one time.

For example, several former employees win a lawsuit in the 4th quarter stipulating that their employer pay them back wages for services rendered during the 1st quarter. During the 4th quarter (the quarter in which the back wages are paid), the former employees would not be counted as employed (performed no work during the 4th quarter) but the wages would be included in the total wages figure for the 4th quarter.

Although back wages are included in the total wage figure, any additional payments unrelated to the previous employment (for example, punitive damages) should not be included in total wages.

Early Retirement Payments

Often, large corporations offer their employees an “early retirement incentive” or “early buyout” to leave their positions before the standard retirement age. In many cases, employees will have a choice of taking a lump sum payment or receiving a salary continuation for a fixed period of time after they stop working.

If an individual receives a **lump sum** early retirement payment, the payment should be included in the total wages in the quarter it was paid. The individual should not be counted as employed in any 12th of the month reference pay period of the quarter following the individuals’ departure.

In the event that the individual is receiving a **salary continuation**, the regular payment should be included in total wages for each quarter in which the payments were made. The employee should be included in the monthly employment counts for each month payment was made.

Severance Pay

When a firm permanently lays off members of its workforce, the former employees will often be compensated in the form of severance payments. Severance payments are typically made in lump sum, but some employers may choose to distribute the payment in installments.

If a **lump sum severance payment** is made, the employer should report the payment in total wages during the quarter that the payment was made. An individual receiving a lump sum severance payment should not be counted as employed during payroll periods including the 12th of the month following their departure. A layoff with lump sum severance payments typically results in a lower employment count relative to the total wages figure (that is, higher average wages).

If the permanently laid-off employee is receiving **severance pay in installments**, the person is considered to be on paid administrative leave. Because a regular check is being received, the individual should be included in the monthly employment counts during which payments are received, and the severance payments should be included with total quarterly wages. This

scenario is distinct from employees that, after having been laid off, are receiving both UI benefits and supplemental pay from their former employer. (See “Supplemental Pay During Layoff Status” later in this section.)

Sick or Disability Payments by Third Party Insurance Companies

Many employees on extended sick or disability leave continue to receive pay from their employers. In some cases, the employer has taken out insurance to cover these situations and a third party insurance company instead of the employer makes sick or disability payments. Third party insurance company payments deserve special attention because of the way they are treated under state UI laws and the potential for the employer to report these employees and payments inaccurately.

Sick or disability pay, paid by either the employer or a third party insurance company, but not paid under Worker’s Compensation, is taxed as wages for the first six months under UI laws in all states. Individuals receiving such pay should be counted as employed and the pay should be included in total wages. Worker’s Compensation payments are never taxed as wages for UI or included in total wages. Persons receiving Worker’s Compensation should not be counted as employed.

If sick or disability pay from the employer and/or third party insurance company continues after six months, it is taxed as wages for UI and included in total wages only in the following states:

Arkansas	New Mexico
Montana	North Carolina
Nebraska	Puerto Rico
New Hampshire	South Dakota

When third party sick and disability payments are taxed for UI, associated employees should not be counted as employed twice in the event that the employer pays part of the salary during the illness and the third party insurance company makes up the difference. That is, if the associated employee is given two separate checks, the employee must only be counted as employed once.

It is also important that the employment and wages be reported for the correct reference period. Insurance companies do not have to report to the employer the sick or disability payments they make until the 15th of the following month. This time lag may cause an employer to report employment and pay in the wrong month or quarter. Employment and wages should be included in the state system and the EQUI for the reference period in which the payment was actually made by the insurance company.

To ensure that the data are reported correctly, state QCEW staff should evaluate each case individually and question the employer about the following factors:

1. The employer’s policy with an insurance company.

2. Whether the employer also makes payment to the employee along with the insurance company.
3. How the employer's payroll system is programmed to pick up these payments for UI/QCEW purposes (does it check for duplicate payments, ignore the payments, or report the employees and payments for the wrong reference period).
4. If the employer uses a payroll service bureau, how the payroll service bureau's tax system is programmed to pick up these payments.
5. How long a time period the payments have been made to determine whether they are still taxable under the state's UI law and should be reported.

Stock Options

Many professionals and executives receive company stock options from their employers as part of their compensation, often as a form of bonus or incentive pay. Both federal and state unemployment insurance laws have defined covered wages to include remuneration other than cash. Therefore, unless stock options are specifically excluded from the definition of wages by a State's unemployment insurance laws, they should be reported as wages for QCEW purposes. If state QCEW staff has any concerns about stock options reported by employers, they should contact their UI tax unit for a ruling on their state's law.

Supplemental Pay During Layoff Status

If an employee of a firm is placed on a temporary or permanent layoff, an employer may choose to supplement, with a regular check, the unemployment insurance benefits being received by the former employer. Often, the supplement pay will make up the difference between the employee's unemployment insurance check and regular pay, or some percentage of that difference. Employees who receive UI payments that are supplemented by company checks, even if they are distributed regularly through payroll, should not be counted as employed. The supplemental pay should not be included in total wages.

Note that a firm may have different procedures for handling temporary or permanent layoffs depending on the specific company contract. The special procedures can potentially impact whether employment, wages, or both are included in the state system and the EQUI. Questions should be directed to the appropriate regional office.

Vacation Funds

Establishments that manage vacation funds for employee groups are classified in NAICS 525120, "Health and Welfare Funds." These types of establishments invest employee-contributed funds on their behalf and then distribute the moneys to the participants once a year. When vacation moneys are distributed, these establishments may incorrectly report a count of the checks issued to participants as employment. While the moneys paid out to participants should be reported as wages during the reference period in which the payments are made, the recipients

should not be counted in employment. Only those persons employed in managing the funds should be counted in employment. Large once-a-year increases in employment in NAICS 525120 should be investigated even if the increases are reflected in historical data. All of the large increase in NAICS 525 should be reviewed.

NAICS 525 - Funds, Trusts, and Other Financial Vehicles is a NAICS Subsector that was created during the conversion from SIC to NAICS. According to the NAICS manual, this subsector is comprised of “legal entities” that have “little or no employment and no revenue from the sale of services.” The manual directs that establishments that are engaged in managing funds, trust, and other financial vehicles be classified in NAICS 5239 – Portfolio Management. For more information, see QCEW S-13-03 and S-19-04.

Workers Paid During a Strike

If employees are on strike but are still collecting pay from their employer for personal leave (annual or sick), the individuals should continue to be counted as employed, and their pay included in total wages.

15.3 Problem Industries

Professional Employer Organizations (PEOs)

NAICS 561330, “Professional Employer Organizations,” includes employee-leasing companies, which lease employees to client firms on a contractual basis. Many businesses, small businesses in particular, have found it financially advantageous to transfer their workers to employee leasing companies because the arrangement relieves the businesses of human resource and administrative work. It also allows more time to be devoted to the actual business and offers their workers access to potentially better benefits that otherwise would not be affordable. The advantages gained by using a leasing company have led many employers to enter into this arrangement. A key aspect of the leasing firm/client relationship is that the employees of the client that are subsequently leased from the leasing firm are now considered to be employees of the leasing firm. This leads to the erroneous reporting of leased employees in NAICS 561330, when in reality they are working in other industries.

To obtain accurate data from employee leasing companies and their clients, the state should treat establishments taken over by a leasing firm as sub-units of the leasing firm. Employment and wage data for a sub-unit should be classified using the industry code that correctly identifies the primary industrial activity of the sub-unit and in the geographic location (state and county) in which the sub-unit is physically located, not the state and county of the leasing firm. Only the staff in the leasing company’s administrative offices should be coded in NAICS 561330 and the

geographical code of the leasing company. To obtain this information, states will need to request that all leasing companies file a Multiple Worksite Report listing all of their clients' worksites.

In most cases, only a small portion (executives & managers) or none of the client's staff will remain on the payroll of the original firm. The workers normally are transferred to the leasing company. If the executives and management staff do not move to the leasing company, the client firm's account would remain active in the UI system and the state system. The remaining employees would still be reported under the old UI account. QCEW staff should ask the appropriate UI staff in their State for assistance to determine exactly how leasing firms are administered in their State.

When a leasing firm initially breaks out their clients by worksite, they should provide the clients' trade names, former UI account numbers (predecessors), physical location addresses, and a description of their client's economic activities. If their client's industry code is unknown, the state staff should collect this information as well. Predecessor UI numbers and successor UI numbers need to be assigned to each worksite. They allow for longitudinal tracking of an establishment. See Section 5.1 for more information on assigning predecessor/successor UI/RUNs. With the UI account number, states have the ability to locate a client's previous record on their state system. From this previous record, industry and geographic codes can be determined and applied to the new record reported by the leasing company. The address and industry description information reported by the leasing company for the client should be used to ensure that the present industry and geographic codes are correct. If the existing codes do not compare with the information reported by the leasing company, the state should call the leasing company to ensure that the correct codes are assigned. If a client is found to have incorrect industry and/or geographic codes, the correct codes should be assigned both to the client's record reported by the leasing company and to the client's original record. These changes, however, should be held until the following first quarter, as described below.

States should include on the Code Change Supplement any shifts in employment and wages from the NAICS code and geographic area of leasing companies to the NAICS code and area of clients and vice versa. The procedures for doing so appear in Chapter 11. When an employee leasing company that previously did not break out their clients' worksites begins reporting by worksite, the clients' employment and wages that were being reported in NAICS 561330 and in the geographic area of the leasing company need to be placed into their proper industries and areas, as described above. This action is considered to be a non-economic code change and should be made effective as of the beginning of the calendar year.

For example, a leasing company using the MWR for the first time in the second quarter reports a restaurant with 50 employees. In this case, a code change has to be made to show 50 employees moving from NAICS 561330 to NAICS 722511 and from the geographic area of the leasing company to the area of the restaurant, if necessary, as of the subsequent first quarter. The MWR for the second, third, and fourth quarter will still be collected, but the employment and wages of the client will remain in NAICS 561330 and the geographic code of the leasing company until the following first quarter. The same process would be followed if the restaurant had previously been miscoded in NAICS 722410. The restaurant's original record would remain coded in 722410 until the following first quarter when it would be changed to 722511. The restaurant's

record reported by the leasing company will have NAICS 722410 until 2020/1quarter, when it also will change to 722511.

When an employee-leasing firm completes the MWR on a regular basis and reports a client for the first time, the state should immediately assign the previous industry and geographic code of the client to the new record. This assumes the client is a single location employer. The state should obtain the client's UI account number from the leasing company and use it to locate the client's previous record. Once it is located and verified, use it to assign the client record's Predecessor UI and Reporting Unit Numbers.

If the client operates multiple worksites, the state should check that the client also filed an MWR. If the client did provide an MWR, then the industry and geographic codes of the worksites should be assigned to the corresponding worksites reported by the leasing company. If the client did not provide an MWR, then all of the client's worksites should be assigned the present industry and geographic code of the client. These code changes should once again be held until the following first quarter. The state should also compare the client's worksites as reported by the leasing company to the worksites reported by the client to ensure that duplicate reporting does not occur or that a month or more of reporting is not mistakenly skipped. If the state encounters any problems during this process, they should contact their regional offices for assistance.

States should investigate large, sudden growth in employment in NAICS 561330 to ensure that it is not due to inaccurate reporting by leasing companies. If multi-state employee leasing companies are found to be reporting incorrectly, states should refer these to their regional office for forwarding to the national office for further follow-up and evaluation.

Education Industry

Some employees in the education industry may be paid less frequently than once a month. For example, adjunct professors may receive remuneration once or twice while teaching during an entire semester (which typically lasts four months). Some school bus drivers may be paid every six weeks. This would erroneously reduce the employment count whenever a non-payment month occurred. The state should advise the employer to include these individuals in the employment counts each month. To accomplish this goal may entail manual adjustment of each month's employment count by a fixed amount.

Also in the education industry, many college professors are paid to teach a fixed number of courses. If they teach more than that number, they may receive additional compensation in the form of more than one check. In this case, the individual should only be included in the employment count once. See Count of Checks (Payments) Issued.

University/Teaching Hospitals

Many state universities and larger private universities operate hospitals from which medical schools are based. Others have affiliations with a public or private hospital from which they conduct their medical school programs. The university units and hospital units should be reported separately in NAICS 611310 and NAICS 622110, respectively. However, there may be a tendency by some institutions to count workers in both the university and hospital reporting units. Employment may also shift back and forth between the units. Data inconsistencies should be checked with the employer to ensure that there is no double count.

Television and Film Industry

Payroll practices in the Television and Film Industry often cause confusion. There are two distinct situations that occur in the industry, one of which is reported, the other excluded.

An actor under contract for a television series typically shoots a season's worth of episodes in a two-to-three month period. The actor is not actually working on the series during the rest of the year, but is paid throughout the season contract period. Since such actors are under contract, they are still considered as employed and are ineligible for UI benefits during that period. Therefore, their employment and wages should be reported on the state system and the EQUI throughout the contract period even though they are not technically at work.

An actor, no longer under contract for specific advertising commercial or television series work, receives "residual" payments for that work when it is re-broadcast. Residual payments are often made many years after the actual work is performed. These actors should not be counted as employed nor should the residual payments be included in total wages. Furthermore, unemployed actors receiving residual payments are eligible for UI benefits, albeit reduced. It would be contradictory to count a person eligible for or receiving UI benefits as employed on the state system and the EQUI.

15.4 Related S-Memos

Some S-memorandums clarify handling of coverage and reporting problems. See below for a list.

S-13-02	01/23/13	Assigning NAICS and CTY Codes to Telework Establishments
S-13-03	04/11/13	NAICS Coding Review for establishments classified in NAICS 525

- S-18-01 01/18/18 Assigning Industry Classification for Temporary Help Agencies
- S-18-02 01/18/18 Assigning Industry Classification for Online Retail Enterprises
(Revised)
- S-18-03 01/18/18 Assigning Industry Classification for Wholesale Trade
Representatives and Offices (Revised)
- S-18-09 04/04/18 Multi Breakout and Proration Guidance for Large Online Retail
Firm (LOR)
- S-19-03 01/23/19 Treatment of North American Industry Classification System
(NAICS) 551114 - Corporate, Subsidiary, and Regional Managing Offices in Quarterly Census
of Employment and Wages (QCEW)
- S-19-04 01/23/19 Update to North American Industry Classification System
(NAICS) Guidance for Qualified Settlement Funds (QSFs)
- S-19-05 01/28/19 Treatment of Factoryless Good Producers (FGPs) in the Quarterly
Census of Employment and Wages (QCEW)

Appendix A – Flowcharts

----- Contents of Appendix A -----

- A.1 Main Processing Flow
- A.2 Annual Refiling Survey: Web & State Collection
- A.3 Centrally Collected MWR and Federal Data from EDIC
- A.4 MWR Data Collected in State
- A.5 Processing existing multi-establishment employers

A.1 Main Processing Flow

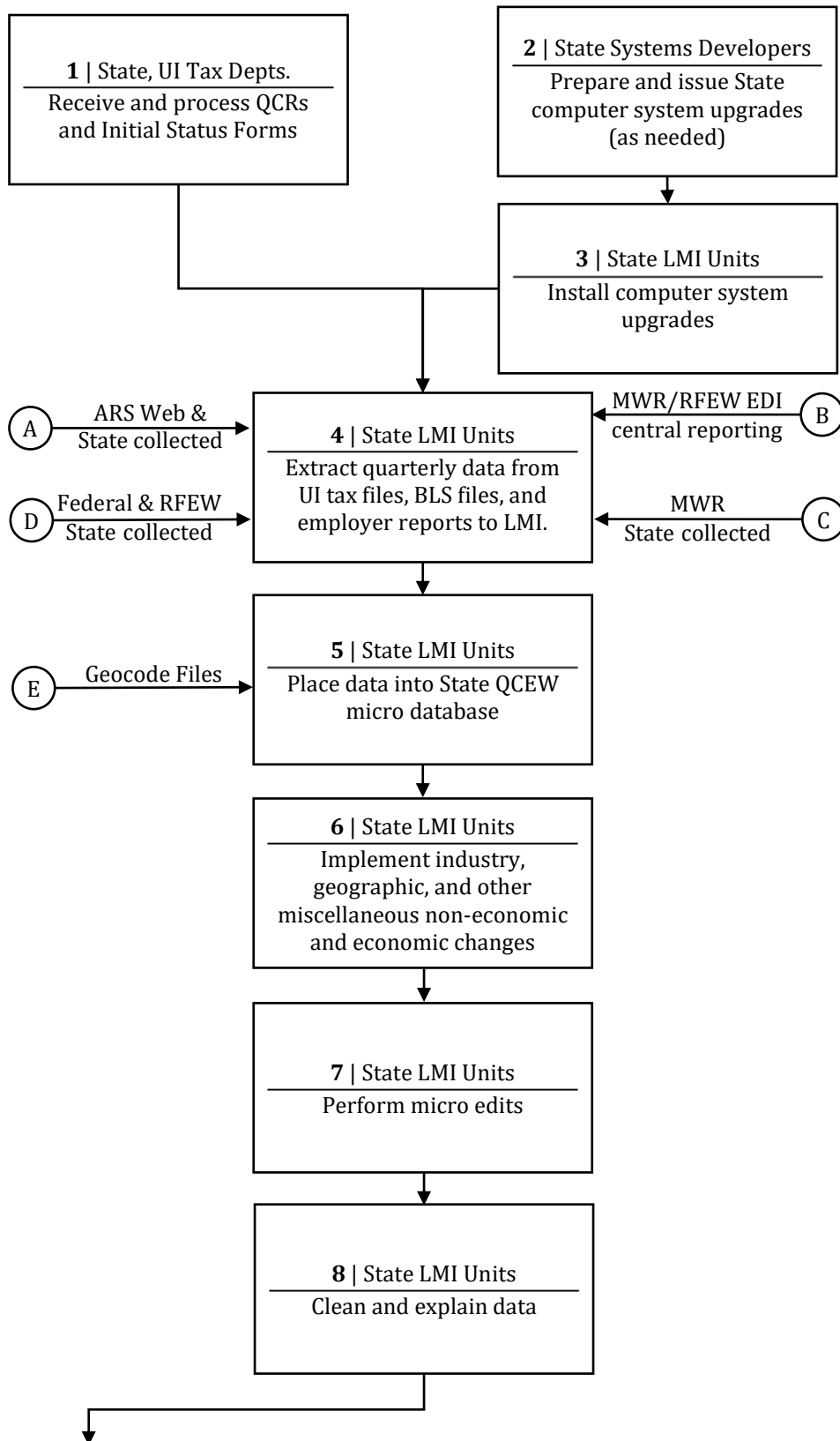

Main Processing Flow (continued)

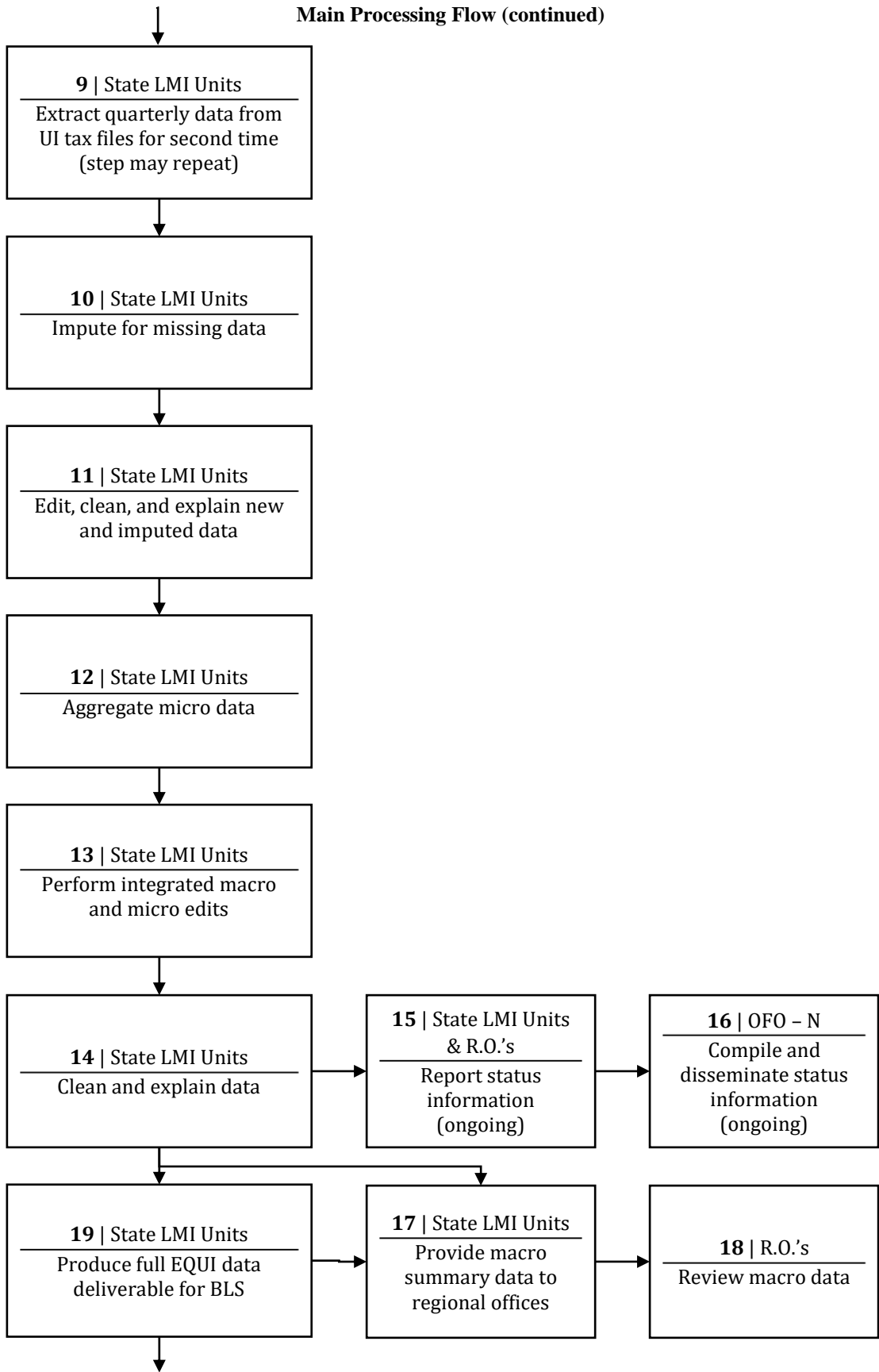

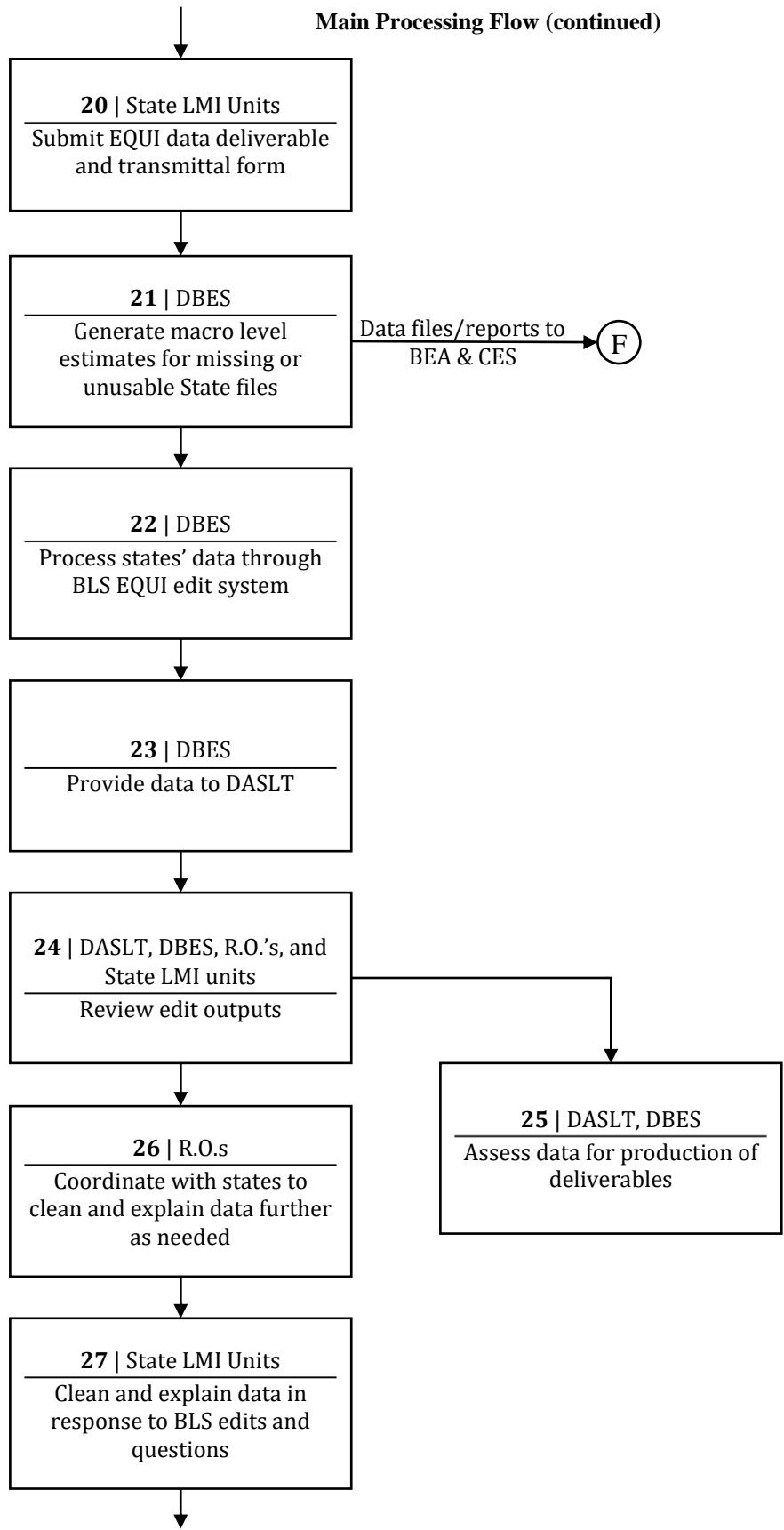

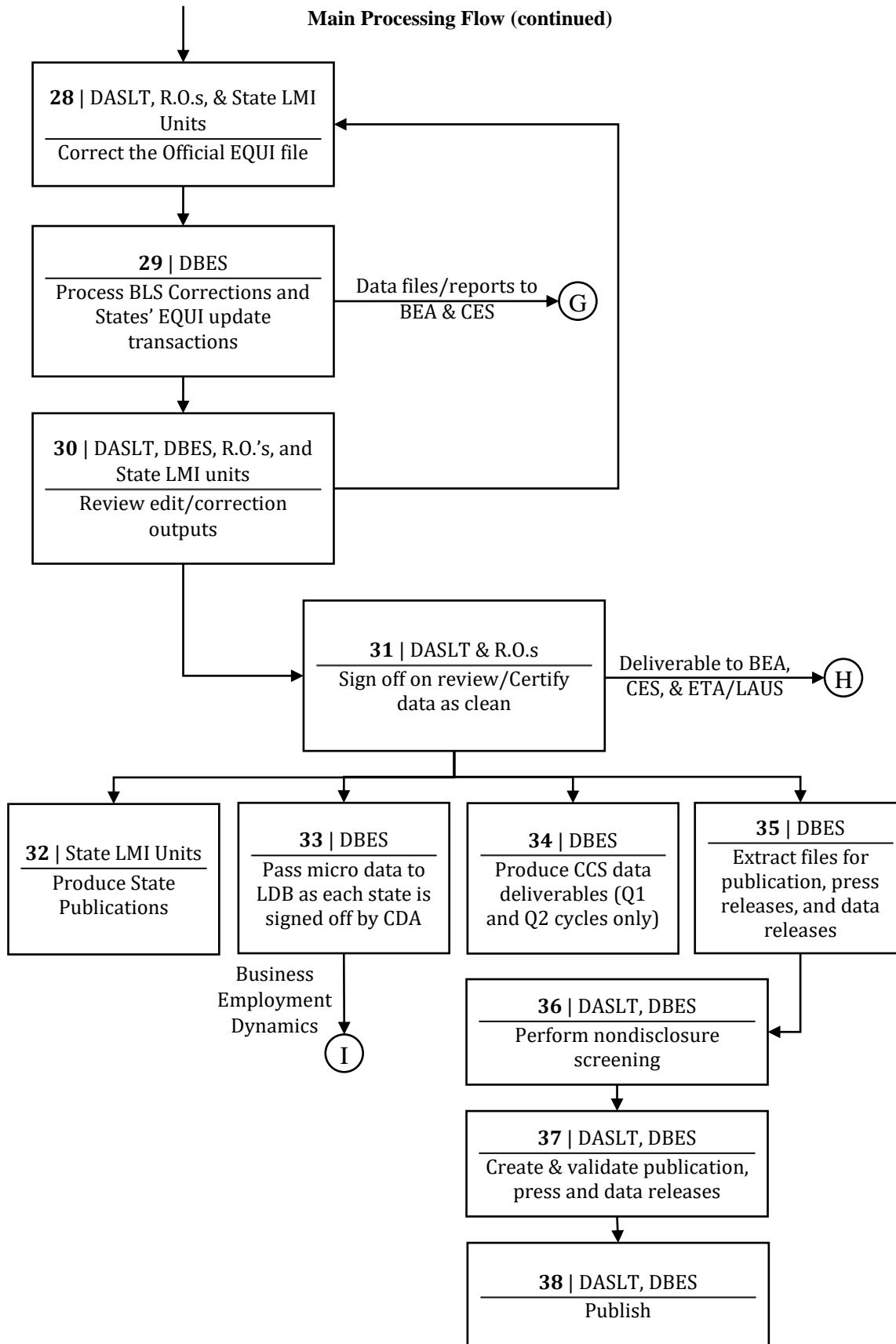

A.2 Annual Refiling Survey: Web & State Collection

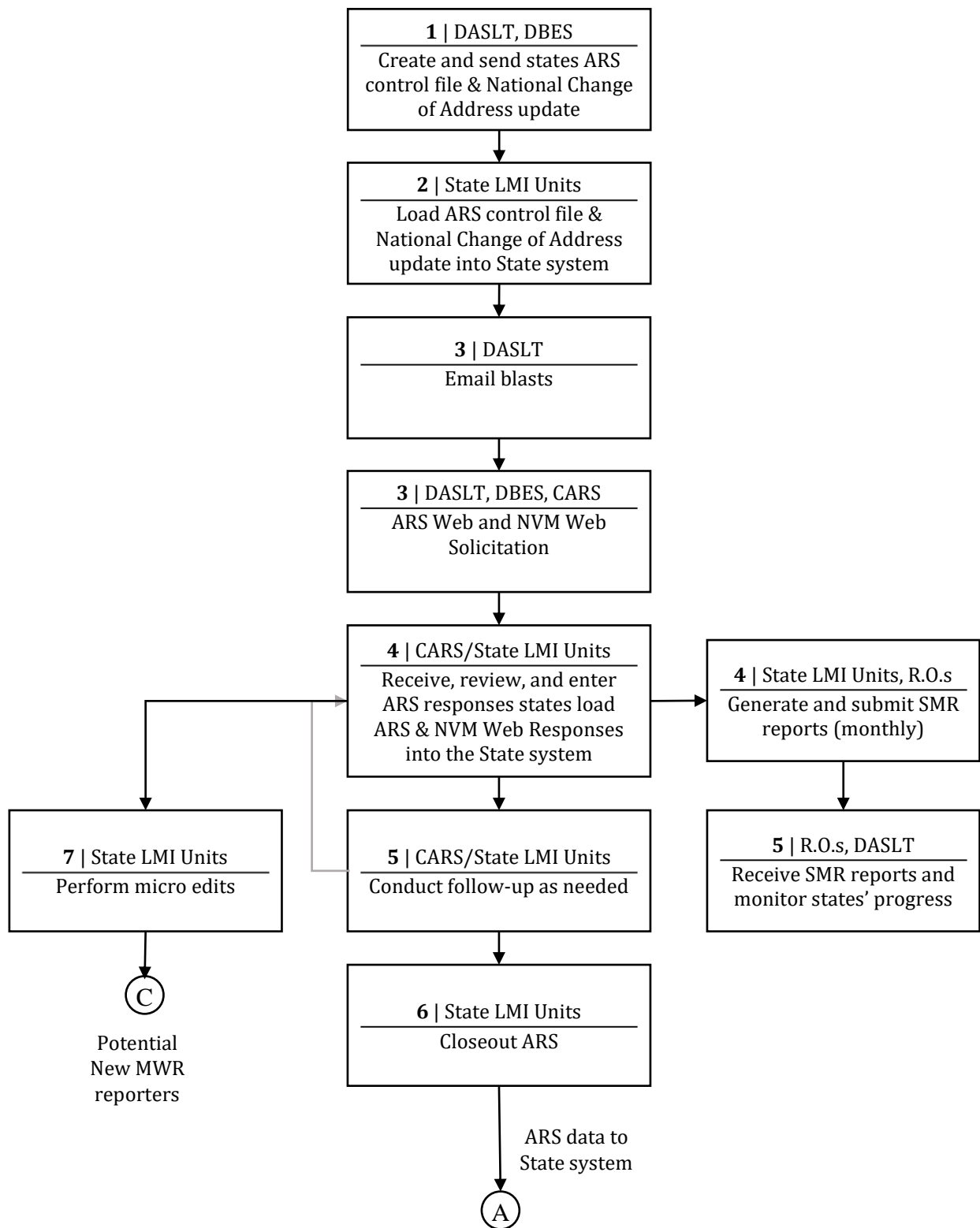

A.4 MWR* Data Collected in State

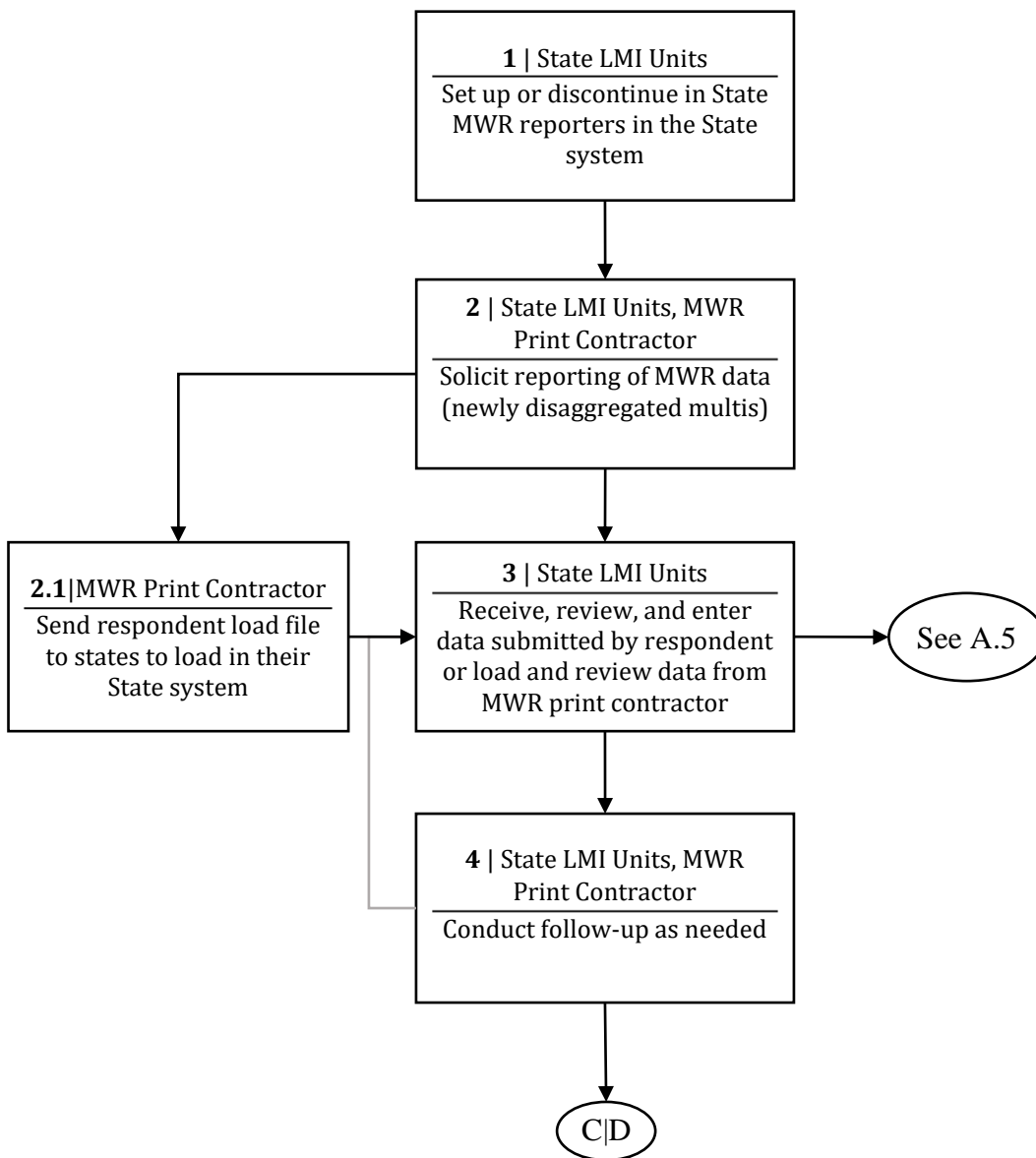

* This process may also apply to RFEW data collection

A.5 Processing existing multi-establishment employers

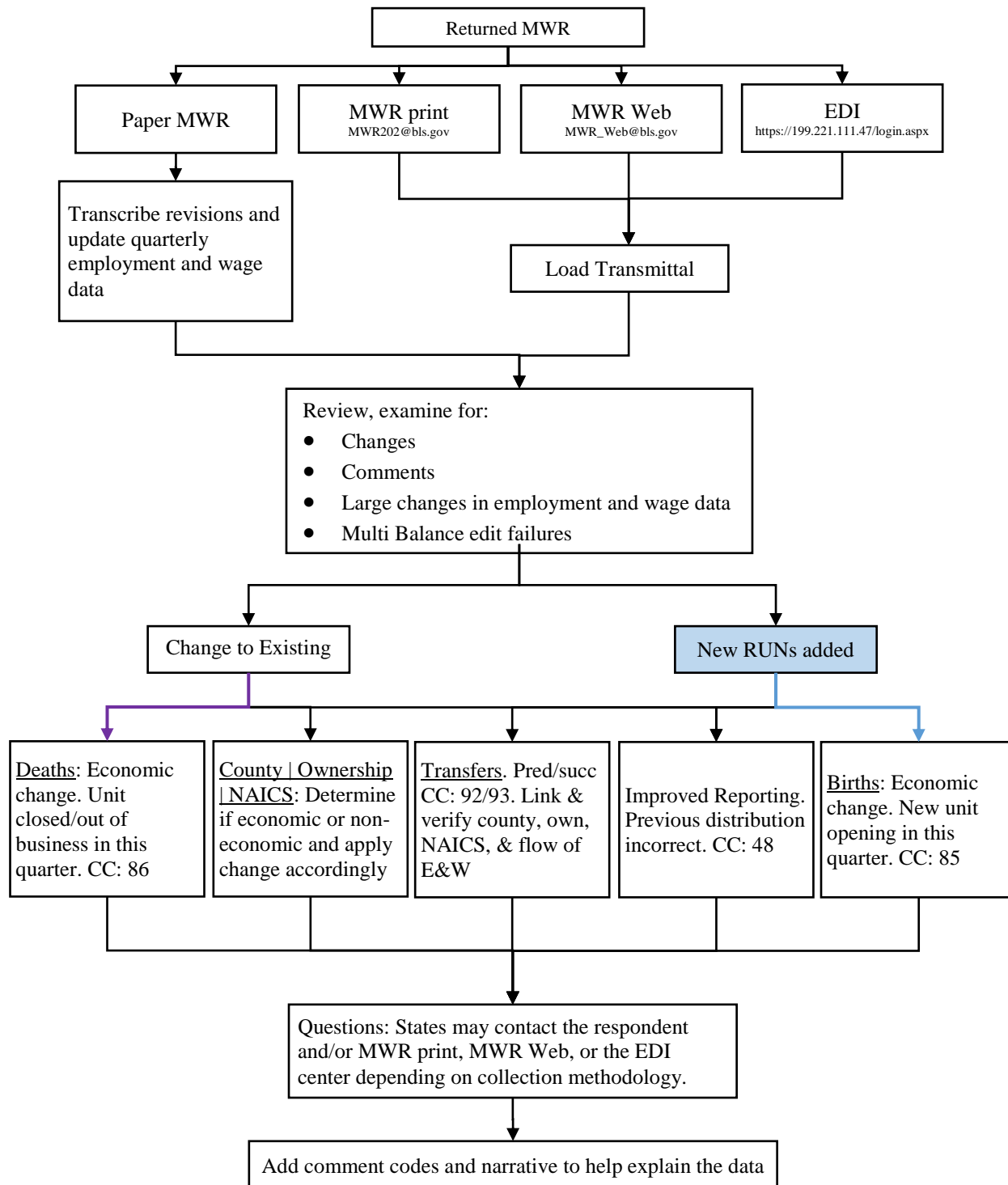

Appendix B – Data Element Definitions

The following are data elements used in the QCEW program. Nearly all of these elements are included on the QCEW micro file database or in supplemental files in the state and national office systems, while most are also on the Enhanced Quarterly Unemployment Insurance (EQUI) file (shown in Appendix K). The following descriptive information is provided for some or all of the data elements:

<i>Descriptive Information</i>	<i>Explanation</i>
Requirement level	Shows whether the data element is required, optional, required when available, and so on.
EQUI:	Identifies if the data field is included, if available, on the EQUI record or supplemental EQUI predecessor/successor (P/S) record
	“Include, P/S Record” identifies that the field is included on the supplemental EQUI with additional predecessor/successor information.
Positions:	Positions where the field is found on the regular EQUI record or on the supplemental separate EQUI predecessor/successor record, if applicable
Frequency:	Non-quarterly (most administrative and address data appearing on the micro file once) or quarterly (most economic and code data appearing on the micro file for each quarter)
Field Length:	Number of positions allowed for the data element on each record
Type:	Description of the field as numeric or alphanumeric
Default Value:	Known default values (e.g., if unknown, zero-fill)
Alternate Name:	Frequently used abbreviation or alternate names used for the field (e.g., OWN for ownership code)
Format:	Description of special formatting required (e.g., date fields are: four positions for year, two for month, and two for day or YYYYMMDD)
Source:	Data source for states to obtain this information (e.g., state Unemployment Insurance (UI) system, system-assigned, assigned by QCEW staff)
Definition:	Precise definition of the data element

Descriptive Information***Explanation***

Valid Values:

Valid values associated with the field if valid values must be used (e.g., Multi-establishment Employer Indicator (MEEI) codes must equal 1, 2, 3, 4, 5, or 6). In some cases, the appropriate appendix reference is cited instead of repeating a long list.

System Action or Notes:

Special notes related to a particular data element

Example

Examples used to clarify the proper definition or to demonstrate specific cases or scenarios

Caution

Special instructions and warnings related to the proper use of the data element

Rounding Criteria:

Procedures for rounding certain numeric fields such as Total and Taxable Wages

Data elements are typically listed in alphabetic order. In some cases, (e.g., monthly employment) data are clustered together.

A

Action Code (Predecessor/Successor)

(Required)

<u>EQUI:</u>	Include, P/S record	<u>Positions:</u>	20		
<u>Frequency:</u>	Transaction	<u>Field Length:</u>	1	<u>Type:</u>	Alphanumeric
<u>Default Value:</u>	Blank	<u>Alternate Names:</u>	PS-Action		
<u>Source:</u>	System-assigned				

Definition: Identifies the situation on the EQUI where the predecessor/successor transaction should be added or deleted from BLS files. The UI account/Reporting Unit Number (RUN), format type, and predecessor or successor UI account/RUN combine to identify a unique linkage. Changes to other fields on the supplemental EQUI P/S record such as source codes and comment information update the existing linkage information.

Valid Values:

D = Delete the transaction information
Blank = Add/update the transaction information

Address/Contact Source

(Optional)

<u>EQUI:</u>	Include	<u>Position:</u>	798		
<u>Frequency:</u>	Non-quarterly	<u>Field Length:</u>	1	<u>Type:</u>	Alphanumeric
<u>Default Value:</u>	Blank	<u>Alternate Names:</u>	Address Source, Contact Source, PL-SO, addr-source		

Source: State UI system (if available), Web collection, outside sources such as InfoUSA or Dunn and Bradstreet

Definition: Identifies if the physical location address was obtained through a traditional QCEW source or a more non-traditional source.

Valid Values:

R = Annual Refiling Survey (ARS) refiling
A* = Current Employment Statistics (CES) Program
E = Employer Contact
F* = Occupational Employment Statistics (OES) Federal/State Program
W = Web
S = Status Determination Form
I = InfoUSA
T = UI Tax system
O = Other

*Note: The use of codes A and F is no longer acceptable since information from the CES and OES programs cannot be used in the QCEW microdata.

Agent Code

(Required if available and maintained by UI and/or obtained from agent submittal tapes)

<u>EQUI:</u>	Include	<u>Positions:</u>	577-580		
<u>Frequency:</u>	Quarterly	<u>Field Length:</u>	4	<u>Type:</u>	Alphanumeric

Default Value: Blank Alternate Names: Third Party Agent, PPF, AGENT, agent_cd

Format: Right justified with leading zeros if numeric, left justified if alphanumeric

Source: State UI system; Payroll provider or tax filer code if obtained and maintained directly from agent reported files listing each client for the reference quarter.

Definition: Identifies the source of the reported data. This code should be used only if it is updated on a regular basis by UI or the agent and readily available. The Agent Code will be used to identify companies, such as payroll providing firms and tax filing firms, who file UI reports for other establishments. This identifier information will be very useful in conducting research on reporting procedures.

Special Criteria: A master list of each state's codes (if used) must be submitted to national office. The list would normally include national payroll providers and national tax filers. An updated list must be provided each year by those states using/providing this information.

Special Processing: A mechanism is required to ensure that this field is properly maintained. If an employer ceases to use the services of a particular agent, the agent code should not be used after the quarter for which the agent reported data.

Caution: Do not use this field if it is not readily available and maintained by UI or information provided by the agent. Although this field will not be edited, it will be used for research purposes. Standardized codes for commonly used agents may be established in the future.

Note: The "QCEW System Developers Guide for Standardized UI Extract", which can be found on Stateweb, calls for this field to be extracted using a field length of 10. When loaded to EXPO or WIN, these are truncated to the first four positions.

ARS Response Code

(Required if ever refiled)

EQUI: Include Positions: 546-547

Frequency: Non-Quarterly Field Length: 2 Type: Numeric

Default Value: Blank Alternate Names: Refile Code, ARS Code, RC, response-cd

Source: ARS Control File (as provided by BLS and loaded by states into their standard state QCEW system); QCEW staff (user updates to the micro file); Centralized Annual Refiling Survey (CARS) system.

Definition: On the ARS Refiling Control File, this code gives the processing status of a record included in the refiling survey. On the state and national office micro files, this code shows the status of a record when it was last refiled or when it was subsequently updated for purposes of generating the CCS, as described in Chapter 11. This information is maintained until the next refiling or noneconomic change to the NAICS, county, township (New England and New Jersey) or ownership codes. For example, if the record was refiled in 2014, the ARS Response Code for that refiling record would be retained through the 2016/4 data on the EQUI submittal. It would change if refiled in 2017/1 or if one of the codes were changed earlier.

Valid Values: The valid ARS Response Code values and definitions are provided in Appendix Q.

Caution: These data are not available from UI tax files. This information is loaded to the control file from BLS-created ARS control files, batch updates, CARS, scanning, system action, or manually. The control file is used to update the micro files in EXPO. The micro file can also be updated manually on a limited basis or for late ARS updates made after the control file was

copied to the microdata file for the last time . In the WIN system, the NAICS, ownership, and area codes are maintained in the micro file while the control file information maintains the ARS Refile Year and ARS Response Code.

ARS Refile Year

(Required if refiled)

<u>EQUI:</u>	Include	<u>Positions:</u>	548-551
<u>Frequency:</u>	Non-quarterly	<u>Field Length:</u>	4 <u>Type:</u> Numeric
<u>Default Value:</u>	Blank	<u>Alternate Names:</u>	ARS Year, Response Year, REFYR, refile-yr

Format: YYYY (four-digit year, e.g., "2017")

Source: ARS Control File (system transferred as discussed below); QCEW staff (user updates to the micro file).

Definition: Fiscal year in which the record was last included in the ARS, or was last included on the CCS, or the reference year that reflected the noneconomic code change.

Valid Values: Year greater than 1996

Sources of ARS Response Code and ARS Refile Year:

The state QCEW systems transfer several data elements from their ARS refiling systems to their QCEW micro file database, preferably during first quarter processing. Data elements that are transferred include ARS Response Code and ARS Refile Year. These two fields are used to generate the Code Change Supplement (CCS) file, and to show when the reporting unit was last surveyed and what response was recorded or when the reporting unit had its latest noneconomic code change.

Example: BLS and states begin refiling activity in summer 2016 and conclude it in late spring or early summer of 2017, so the ARS Refile Year is 2017 (both the fiscal year of the ARS and the reference year when the ARS codes would be made effective). The ARS Refile Year as well as the ARS Response Code would be passed from the refiling system to the micro file for first quarter 2017 processing. If the survey identified a noneconomic code change, that change would be implemented in the 2017 first quarter. The ARS Refile Year and ARS Response Code on the micro file work together in the state and national office systems to place the reporting unit on the 2017 CCS file.

Note: Some noneconomic code changes are identified from sources other than the ARS, including multi-unit breakouts and consolidations; in addition, some code changes are identified too late to be entered through the refiling system. Therefore, QCEW staff may need to update ARS Refile Year, ARS Response Code, and other fields directly on the micro file and/or Control File.

Caution: This information is not extracted from the UI tax file. Reference EXPO or WIN documentation for system-specific details.

ARS Verification Year

(Required if available)

<u>EQUI:</u>	Include	<u>Positions:</u>	556-559
<u>Frequency:</u>	Non-quarterly	<u>Field Length:</u>	4 <u>Type:</u> Numeric
<u>Default Value:</u>	Blank	<u>Alternate Names:</u>	ARS Year, ARS Verification Year, Verify Year, VFYYR

Format: YYYY (four-digit year, e.g., "2017")

Source: System assigned. This field will be system generated in the state systems.

Definition: Fiscal year in which the reporting unit last received a usable ARS response. When the ARS Response Code and ARS Refile Year are copied from the ARS system to the micro file, the system copies the ARS Refile Year to this field if the ARS Response Code is one of the following:

41	Reviewed, no refiling changes (no NAICS, county, township (New England or New Jersey only) or ownership change) on a single or subunit record. Response Code 41 is also assigned to a reviewed master record (MEEI =2) with or without any code changes. This code is also used for refiling records that changed from unclassified to classified area where the NAICS is unchanged.
42	Employer misunderstood industry description but codes are correct.
46	Clean record with CCS updates from the ARS refiling. Noneconomic code change made to NAICS, county, township (New England and New Jersey only) or ownership.
50	Code changes from non-refiling sources. Noneconomic code change made to NAICS, county, township (New England and New Jersey only) or ownership but not from the ARS refiling.
57*	Code changes from non-refiling sources. Noneconomic code change made to the 2002 NAICS resulting in a 2007 NAICS code as well.
76*	Code change to industry code, county, township (New England and New Jersey only) or ownership also results in a NAICS 2007 code assignment.
77*	2007 NAICS code assigned during refiling but with no correction to the 2002-based NAICS code. (Employer may or may not have misunderstood the industry description but the 2002-based NAICS code was correct.) There were no changes to the county, township (New England and New Jersey only) or ownership codes. Response code 77 will also be system-assigned to those industries that directly map from a specific 2002-based code to one 2007-based code where no other noneconomic code change is made.

***Note:** ARS Response Codes 57, 76, and 77 were used for processing and monitoring the 2007 NAICS revision. They are no longer used.

This data element will allow users in the state and in BLS to tell how recently the existing industry code and other codes were assigned or verified. It is system-assigned based on the ARS Response Code and ARS Refile Year.

Valid Values: Year later than 1996

Caution: This field is derived from the ARS Refile Year and ARS Response Code.

B

Business Transfer Company

(Optional for state systems, not reported on the EQUI)

<u>EQUI:</u>	Exclude	<u>Positions:</u>	N/A		
<u>Frequency:</u>	Non-quarterly	<u>Field Length:</u>	50	<u>Type:</u>	Alphanumeric
<u>Default Value:</u>	Blank	<u>Alternate Names:</u>	None		
<u>Source:</u>	MWR Web collection system				

Definition: Name of the other company involved in the business transfer event based on information from the respondent and not from the successor account. This information is sent to the state on the MWR Web Collected Data File and is accompanied by a Business Transfer Event Type.

Valid Values for Business Transfer Event Types:

- 1 = Acquired another company
- 2 = Been sold to another company
- 3 = Been in a merger
- 4 = Reorganized
- 5 = Opened a new UI account

C

Census ID

(Required if available)

<u>EQUI:</u>	Include	<u>Positions:</u>	779-793
<u>Frequency:</u>	Quarterly	<u>Field Length:</u>	15 <u>Type:</u> Alphanumeric
<u>Default Value:</u>	Blank	<u>Alternate Names:</u>	census-id, BLOCK, BL-ST, BLCTY, BLBLK, BLTRA

Source: BLS-supplied from Global Innovative Systems softwareDefinition: Census ID is a 15 digit field that is actually comprised of

- 2 digit state FIPS code
- 3 digit county code assigned by the geocoding software
- 6 digit tract code
- 1 digit block code
- 3 digit detailed block classification (this may or may not be assigned to a record based on the Physical Location Address (PLA))

Caution: Portions of this field may be blank. The county code generated by the geocoding software may differ from the quarterly county code. When reconciling these differences between the geocoded county and the one on the file, any change to the quarterly county code would be treated as a noneconomic code change and should be processed appropriately. Also note that if the physical location address changes or the latitude and longitude change, the census ID may also change.

Check Digit

(Optional for state systems)

<u>EQUI:</u>	Exclude	<u>Position:</u>	N/A
<u>Frequency:</u>	Non-quarterly	<u>Field Length:</u>	1 <u>Type:</u> Numeric
<u>Default Value:</u>	Zero or blank	<u>Alternate Names:</u>	Ck Digit; chkdig, CKD
<u>Source:</u>	System generated		

Definition: The UI Account Number check digit. It may or may not be used in a state. It is optional, for use only on state files. Check digits are used in some state tax systems and QCEW systems to ensure that new data and data changes are applied to the proper record and not accidentally to the wrong record.

Valid Values: 0 through 9, if this element is used.Example: Some states copy UI tax file check digits to the state system when the check digit is needed in conjunction with the UI Account number to access information from the tax file.Note: Some states include the check digit of the account number in EXPO or WIN as part of the ten digit UI account number, typically appended to the right of the UI account number.

Class Code

(Required if available)

EQUI: Include Positions: 777-778
Frequency: Quarterly Field Length: 2 Type: Alphanumeric
Default Value: Blank Alternate Names: Class, City Class , city-id,
Format: First position is a letter and the second position is either blank or a number
Source: BLS-assigned and forwarded to states in conjunction with place codes.

Definition: Class code identifier that explains the Place/City code field. If no place/city code is assigned, then no class code will be assigned either.

Valid Values:

Class C1-C9: Incorporated Places
 Class U1-U9: Populated (Community) Places (Except Those Associated with Facilities)
 Class D1-D9: American Indian Areas
 Class E1-E7: Alaska Native Areas
 Class H1-H6: Counties and County Equivalents
 Class T1-T5: Active Minor Civil Divisions
 Class Z1-Z8: Inactive or Nonfunctioning Primary County Divisions
 Class G: Nongovernment Facilities
 Class M1-M9: Federal Facilities
 Class N1-N9: State, Local, and International Government Facilities
 Class A1-A5: Airports
 Class B: Post Offices Not Corresponding to Other Locational Entities
 Class S: Surface Transportation Facilities
 Class X1-X6: Obsolete or Incorrect Names or Entities

Note: For more detailed information, use the following website:

<https://www.census.gov/geo/reference/class.html>

Special Handling: If the place/city code is blank, blank out class codes as well. If the place/city code is assigned, also include the class code. If deleting an incorrect place/city code, also remove the class code.

Collection Mode Indicator (CMI)

(Required)

EQUI: Include Positions: 725-726
Frequency: Non-quarterly Field Length: 2 Type: Numeric
Default Value: Blank Alternate Names: CMI
Source: System-assigned in some cases by the state systems, ARS Control File, CARS
Definition: This code identifies records with ARS responses collected by the ARS Web system.

Valid Values: The valid Collection Mode indicator values and definitions are provided in Appendix Q.

Collection Status ID

(Provided from web collection systems)

<u>EQUI:</u>	Exclude	<u>Position:</u>	N/A
<u>Frequency:</u>	Non-quarterly	<u>Field Length:</u>	1 <u>Type:</u> Alphanumeric
<u>Default Value:</u>	Blank	<u>Alternate Names:</u>	None
<u>Source:</u>	Web collection systems		

Definition: Information from the web collection systems regarding the collection status of the Multiple Worksite Report (MWR) information sent to the states on the MWR Web Collected Data File.

Valid Values:

- 1 = No action required
- 2 = Change mail indicator to Y and resume sending MWR forms to the respondent
- 3 = Employer is now a single worksite account. State action is required. This information will be printed out in EXPO and WIN so that the state QCEW analyst knows that an action is needed.
- 4 = UI account is no longer active. This information will be printed out in EXPO and WIN so that the state QCEW analyst knows that a potential action is needed.
- 5 = No action required
- 6 = No action required

Comment Code

(Required if available)

<u>EQUI:</u>	Include	<u>Positions:</u>	662-663, 664-665, 666-667
<u>Frequency:</u>	Quarterly	<u>Field Length:</u>	2 <u>Type:</u> Numeric
<u>Default Value:</u>	Blank	<u>Alternate Names:</u>	CC, CMNT, CMT1, CMT2, CMT3, com_1, com_2, com_3

Source: QCEW Staff; Electronic Data Interchange (EDI) Center (for worksites of centrally collected employers), MWR, MWR Web collection system

Definition: Code used to explain fluctuations or changes in the data, especially changes which cause current records to be flagged as questionable. Only standard QCEW comment codes may be used. These are defined in Appendix I. Additional information on using comment codes can be found in Section 9.6 of the manual.

Note: Three comment code fields, each with a field length of 2, are available in state systems and on the EQUI. When only one comment code is assigned to a record, place it in the first comment code field. When two codes are assigned, place them in the first and second comment code fields.

Valid Values: Comment codes 37, 38, 62-74, and 94 are invalid for the QCEW program. Comment code 99 should only be used if a narrative comment is also provided.

(QCEW) Contact Name (Attention Line)

(Required if available for multi master records, optional for singles, not required for subunits)

<u>EQUI:</u>	Include	<u>Positions:</u>	850-884
<u>Frequency:</u>	Non-quarterly	<u>Field Length:</u>	35 <u>Type:</u> Alphanumeric
<u>Default Value:</u>	Blank	<u>Alternate Names:</u>	Contact Name, Attention Line, Name, contact, CO-NM

Format: Left justified

Source: State UI system (if available); ARS or MWR forms (optional entry), CARS,
MWR Web collection systems.

Definition: Name of a specific person or department (e.g. Payroll Office) to whom the LMI forms or questions are directed. According to U.S. Post Office standards, the contact name or attention line is an optional line for additional address information to facilitate delivery. For those records and information collected via the web, this is the web respondent.

Note: State staffs are not required to manually enter this field.

Caution: If both a UI contact and a MWR contact exist and are different, then enter the MWR contact. Other contact information (e.g., contact title) should match with the contact name. Contact name and contact title should be entered, changed or deleted together. When a name changed, the title may likely change as well.

(QCEW) Contact Title

(Required if available for multi master records, optional for singles, not required for subunits)

<u>EQUI:</u>	Include	<u>Positions:</u>	885-919
<u>Frequency:</u>	Non-quarterly	<u>Field Length:</u>	35 <u>Type:</u> Alphanumeric
<u>Default Value:</u>	Blank	<u>Alternate Names:</u>	Contact Title, Title, contact- title, CO-TI

Format: Left justified

Source: State UI system (if available); ARS or MWR forms (optional entry), CARS,
MWR Web collection systems.

Definition: The title of the contact name provided on the ARS or MWR forms or through the Web collection systems. For example, titles may include: vice president, CEO, accountant, etc.

Note: State staffs are not required to manually enter this field.

Caution: If both a UI contact and a MWR contact exist and are different, then enter the MWR contact title. Other contact information (e.g., contact name) should match with the contact title. Contact name and contact title should be entered, changed or deleted together. When a name changed, the title may likely change as well.

Contributions (Due)

(Required)

<u>EQUI:</u>	Include	<u>Positions:</u>	650-658
<u>Frequency:</u>	Quarterly	<u>Field Length:</u>	9 <u>Type:</u> Numeric
<u>Default Value:</u>	None	<u>Alternate Names:</u>	Contributions, CTB, Insurance Taxes, Taxes, Subject Taxes, contrib, CTRB

Format: Right justified with leading zerosSource: State UI system; system imputations (worksites); QCEW staff (corrections, other); system-calculatedDefinition: Amount of money due to the state for the Unemployment Insurance benefit program for the reference quarter, on all the payrolls during the reference quarter. Currently these data are submitted several ways:

Reported contributions extracted from state UI system

Contributions due extracted from state UI system

Contributions due calculated based on the tax rate

Contributions due prorated for non-reimbursable worksites

Contributions due prorated for reimbursable worksites (Pennsylvania and Alaska)

Total of employer and employee contributions due (Pennsylvania and Alaska)

Contributions paid (California)

Exclusions: Not included in the definition of employer contributions are:

Any tax, surcharge, etc. that is used to pay off the interest on a loan from the federal government to the state trust fund and is required by federal law to be deposited outside the unemployment trust fund

Any temporary excise tax or permanent surcharge tax

The administrative financing excise tax paid to the federal government by all employers of one or more workers in 20 weeks during a calendar year in covered industries

Payments in lieu of contributions by certain nonprofit organizations and state and local government instrumentalities which finance benefit costs on a reimbursing basis

Voluntary contributions (paid by employers in some states to be credited to their experience-rating accounts to obtain more favorable rates for future periods)

Employee contributions: Employee contributions are the unemployment insurance taxes required by some state unemployment compensation laws to be deducted from an employee's pay by the employer and included with the employer's contribution to the state agency.Note: Total contributions, therefore, are a composite of the employer's contribution and, where applicable, the employees' contributions. states collecting employee contributions use special Type of Coverage Codes.Special: All federal accounts must be zero-filled.Rounding Criteria: To the nearest whole dollar amount. For example, if contributions are \$2,465.49, then 000002465, and not 000246549, appears in this field. If contributions are \$2,465.50, then the data are rounded up so that 000002466 appears in this field.

Contributions (Due) Indicator Flag

(Required in state systems)

<u>EQUI:</u>	Exclude	<u>Position:</u>	N/A
<u>Frequency:</u>	Quarterly	<u>Field Length:</u>	1 <u>Type:</u> Alphanumeric
<u>Default Value:</u>	M	<u>Alternate Names:</u>	Contributions Due Imputation Flag, Contributions Flag, Contrib-Ind, Contrib_Ind, CTRBI

Source: 1) System generated for all data entered via extract or batch.
 2) Assigned when data imputed or prorated.
 3) QCEW staff (manual override).

Definition: Indicator showing the source of the Contributions Due.

Valid Values:

- Blank or R = reported data
- C = changed (re-reported)
- E = imputed
- H = hand-imputed (not system generated)
- K = special system-generated imputation to reflect data impacted by a catastrophe
- L = late reported (overrides prior imputation)
- M = missing data
- N = zero-filled pending resolution of long-term delinquent reporter
- P = imputed from prorated taxable wages
- X = non-numeric contributions zero-filled pending further action

Caution: Data imputed (estimated) by UI are not to be copied from the tax files to QCEW files. These UI estimates frequently overstate total and taxable wages to inflate estimated contributions due.

County Code

(Required)

<u>EQUI:</u>	Include	<u>Positions:</u>	599-601
<u>Frequency:</u>	Quarterly	<u>Field Length:</u>	3 <u>Type:</u> Numeric
<u>Default Value:</u>	999 if MEEI = 1, 3-6; 900 if MEEI = 2.	<u>Alternate Names:</u>	Cnty, Cty, FIPS, Location Code, Area, county_cd,

Source: State UI system; QCEW staff (staff research); copied from previous quarter if unchanged on state systems; system-transferred from the ARS Control File in first quarter; EDI Center (for birth records of centrally collected employers), new units collected via the MWR web system, geocoding software based on physical location address information; based on township code/county code crosswalk in New England states and New Jersey

Definition: Three-digit numeric Federal Information Processing Standard (FIPS) code used to identify each reporting unit's location or place of business. Use the code for the county where the reporting unit is located or the county that has the greatest percentage of total employment for the reporting unit, provided 50% or more of the reporting unit's employment is in that county. For mobile and physically dispersed businesses, refer to the county coding standards in Section 2.1.2. If the physical location(s) is located in more than one county, overseas, out-of-state, unknown, or if the employer refuses to provide it, use whichever of the following QCEW equivalent codes is appropriate: 995, 996, 998, or 999. Use of 900 on master records is optional and is not required. For access to complete and current FIPS county codes for all states and territories, visit the web site <https://www.census.gov/geo/reference/codes/cou.html>.

Valid Values: Valid FIPS County codes for the state plus the county equivalent codes. (For a full description of the county equivalent codes, see Section 2.1.2.)

900 = Master record

995 = Statewide with no primary county

996 = Foreign locations

998 = Out-of-state locations

999 = Unknown locations.

Note: The county equivalent codes 900 and 995 first became valid with third quarter 1997 data. County code 994 was only valid from 1997 through 2000.

Current Employment Statistics (CES) Indicator

(Required if available)

<u>EQUI:</u>	Include	<u>Position:</u>	545
<u>Frequency:</u>	Non-quarterly	<u>Field Length:</u>	1
<u>Default Value:</u>	Blank	<u>Type:</u>	Alphanumeric
<u>Source:</u>	System generated by loading CES registry information to QCEW micro files		
		<u>Alternate Names:</u>	CES Ind, ces-ind, CES

Definition: A CES Indicator Code was assigned to a record to identify that a record also existed on the state CES registry and that the firm also participated in the CES program. This code was normally system assigned by the CES/QCEW crosswalk program or other system-specific tools to indicate if a CES/QCEW match occurred. This code was used to assist in data review. It allowed the editor to check CES files for selected employment data for establishments in the CES survey.* This information was also be useful to CES staffs to identify non-sample records, and to assist in reconciling reporting differences.

***Note:** The Confidential Information Protection and Statistical Efficiency Act (CIPSEA) prohibits using CES-sourced information in QCEW microdata. The analyst should not review CES respondent information to correct, impute, or validate QCEW data.

Valid Values: C = CES reporter
blank = not found on the CES file

Caution: This information was updated periodically but may be out-of-date. The CES indicator is not related to the reference date of the QCEW data. Also note, this information is not extracted from UI tax files but from CES files.

D

Data Source

(Required if available)

<u>EQUI:</u>	Include	<u>Position:</u>	575
<u>Frequency:</u>	Quarterly	<u>Field Length:</u>	1 <u>Type:</u> Alphanumeric
<u>Default Value:</u>	Blank	<u>Alternate Names:</u>	Source, EDI indicator, DATSO
<u>Source:</u>	QCEW staff; EDI Center (for worksites of centrally collected employers); MWR Print contractor; tax Web collection; MWR Web collection system		

Definition: Code used to provide information on the source of the data. Until recently this code was only used to identify multi-unit UI accounts whose MWR data are provided by the EDI Center and are not provided directly to the state by employers (or their agents).

Valid Values:

E = EDI record collected by EDIC
 C = EDI sent and loaded from EDIC
 P = MWR Print contractor collected
 S = State-collected magnetic media
 Q = Quarterly Contribution Report (QCR) web collected
 W = MWR Web collected
 X = Other Data Collection
 blank (default value) = All other sources

Note: Masters and subunits may have different codes; for example, the master's data are reported on UI (with Source of Data = blank) while the worksite information is received from the EDI Center (with Source of Data = C) or have the same source code, using the code used on the worksites.

Date PLA Changed (YYYYMMDD)

(Required)

<u>EQUI:</u>	Include	<u>Positions:</u>	730-737
<u>Frequency:</u>	Non-quarterly	<u>Field Length:</u>	8 <u>Type:</u> Numeric
<u>Default Value:</u>	Blank	<u>Alternate Names:</u>	PLA Changed Date, place-dte, PL-DT

Format: YYYYMMDDSource: State system assigned

Definition: Indicates when the physical location address was last changed (YYYYMMDD). This field would be system assigned when either of the two street address lines, city, state, or 5-digit ZIP changes.

Note: A change from a blank zip extension to a zero-filled extension or vice versa does not constitute a change.

Delete Identifier

(This or a comparable mechanism in state systems, delete identifier on national office system)

<u>EQUI:</u>	Include	<u>Position:</u>	1		
<u>Frequency:</u>	Quarterly	<u>Field Length:</u>	1	<u>Type:</u>	Alpha
<u>Default Value:</u>	None	<u>Alternate Names:</u>	1 st County Result		
<u>Source:</u>	State QCEW staff				

Definition: A designation in the system to identify that the state analyst believes that the record should be removed from the file but which will suppress the data where it can be retained and reactivated for the entire period of time or a portion of time it existed as needed.

Caution: Records that were active for a period of time should never be deleted. Only those records that were truly set up in error or which were set up and duplicate an existing record should ever be deleted.

Valid Values: The designation in the state systems can be determined by the developers. BLS uses a "D" in the Transaction File on the EQUI file to identify a record that should be deleted from its files based on state-supplied information.

E

Economic Code Change Indicator (ECCI)

(Required if applicable)

<u>EQUI:</u>	Include	<u>Positions:</u>	727-728
<u>Frequency:</u>	Quarterly	<u>Field Length:</u>	2 <u>Type:</u> Numeric
<u>Default Value:</u>	00	<u>Alternate Names:</u>	ECCI, ecci_cd
<u>Source:</u>	QCEW staff; system generated by summing for combination changes using 01, 02, 04, and 08 for single changes		

Definition: Code assigned to a micro level data record to indicate an economic change in NAICS, County or Township area, or Ownership codes.

Valid Values: 00 through 15

- 00 = No change
- 01 = Economic Township code change
- 02 = Economic NAICS change
- 03 = Economic Township and NAICS code changes
- 04 = Economic Ownership change
- 05 = Economic Township and Ownership code changes
- 06 = Economic NAICS and Ownership code changes
- 07 = Economic Township, NAICS, and Ownership code changes
- 08 = Economic County code change
- 09 = Economic Township and County code changes
- 10 = Economic NAICS and County code changes
- 11 = Economic Township, NAICS, and County code changes
- 12 = Economic Ownership and County code changes
- 13 = Economic Township, Ownership, and County code changes
- 14 = Economic NAICS, Ownership, and County code changes
- 15 = Economic Township, NAICS, Ownership, and County code changes

Summations of these values indicate more than one type of change. For example, an economic change to NAICS (02) plus an economic change to Ownership (04) is indicated by 06 (02 + 04 = 06), a summation of the values. Whereas an economic change to Township (01), NAICS (02), Ownership (04), and County (08) is indicated by a summation of 15 (01 + 02 + 04 + 08 = 15). In EXPO, the economic code change indicators are displayed with a “Y” next to the field with the economic change.

(QCEW Contact) Email Address

(Include if available)

<u>EQUI:</u>	Include	<u>Positions:</u>	920-979
<u>Frequency:</u>	Non-quarterly	<u>Field Length:</u>	60
<u>Default Value:</u>	Blank	<u>Type:</u>	Alphanumeric
		<u>Alternate Names:</u>	URL, electronic mail, computer address, email, EMAIL

Format: Left justified; include all fields including prefixes and suffixes
Source: ARS, ARS Web, and MWR Web collection, state UI system (if available), state QCEW Staff

Definition: The employer or respondent’s e-mail address where the respondent can be contacted directly via email over the internet. This should not be confused with a generic company web site.

Note: Ideally this information will be obtained from other sources and states may opt to manually enter this information if they have it easily available and choose to do so.

Caution: Great care must be taken when using e-mail addresses. Confidential data must not be sent via email to the respondent at any time. The respondent may provide e-mail information to the state if the respondent is informed of the potential risks to confidentiality that may exist.

Employer Identification Number (EIN)

(Required if available)

<u>EQUI:</u>	Include	<u>Positions:</u>	24-32
<u>Frequency:</u>	Non-quarterly	<u>Field Length:</u>	9
<u>Default Value:</u>	Zero-filled	<u>Type:</u>	Numeric
		<u>Alternate Names:</u>	EIN, FEIN, EI Number, Federal Number, IRS Number, Federal Tax Number

Source: State UI system; QCEW staff (for federal reports); EDI Center (for worksites of centrally collected employers)

Definition: A nine-digit Federal Identification number devised by the Internal Revenue Service (IRS) to identify legal entities. The IRS assigns it to corporations or other firms (partnerships or proprietorships). The EIN field should not be used to report the Social Security Number of the individual who owns the firm. QCEW staff tries to obtain the EI Number if it is not available.

In virtually all cases, the master and its subunits should share the same EIN and ownership code.

Valid Values: Cannot start with 07, 08, 09, 17, 18, 19, 28, 29, 49, 78, 79, or 89. Cannot be all ones (111111111), all twos, all threes, all fours, all fives, all sixes, all sevens, all eights, or all nines.

Notes: The EI Number is critical in developing firm linkages on the national office Longitudinal Database (LDB) to identify corporate ownership and relationships within an enterprise. In addition, EI Numbers will be important in potential projects that involve data sharing with other Federal statistical agencies, as the EI Numbers are the common identifier on different agencies’ files.

System Action: When the EIN is assigned to a master record in a multi-unit account, the state system copies the EIN from the master record to the subunit records in the same UI account.

Caution: Some state UI tax files may include Social Security Numbers for EINs. These are edited on a limited basis by checking the first two digits for valid values. Also, note that units with several quarters of zero-filled EINs will be flagged.

End of Liability Date

(Required if available)

<u>EQUI:</u>	Include	<u>Positions:</u>	528-535
<u>Frequency:</u>	Non-quarterly	<u>Field Length:</u>	8 <u>Type:</u> Numeric
<u>Default Value:</u>	Blank	<u>Alternate Names:</u>	EOL Date, EOL, end_liab_date

Format: YYYYMMDD – four positions for year, two for month, and two for day (e.g., "20170331" for March 31, 2017)

Source: State UI system; assigned by QCEW staff for federal reports; system or QCEW staff assigned for worksites (see definition below for a detailed description of how to select the appropriate date). This date would be obtained by extracting the appropriate date from the UI system in most cases. The appropriate date to extract will be determined individually for each state and will depend on the available UI dates. The dates assigned for the MWR reporting units are assigned as of the date the RUN is no longer reported on the MWR, imputed, prorated, or is no longer broken out.

Definition: The date that the business ceases operations or no longer has employees or pays wages. The date applies to singles and master records and is assigned by UI. The date for worksites reported on the MWR reflects the date the establishment actually closed or the closest approximation to that date. Once assigned, this date would not be changed. When a business (UI account) ceases operations and no longer has employees and pays wages, the state UI section assigns a date to the account that represents the date that the unit closed its doors and is no longer required to file quarterly Contribution Reports. In the case of UI accounts, the date assigned would be the UI section assigned date.

In the case of establishments reported on an MWR, if the establishment is closed, the date assigned would be the date the establishment was actually closed or the closest approximation to that date. This date should not be confused by situations where businesses still owe back taxes but are no longer operating and accumulating UI taxes. The date required is the date at which a business no longer has employees and pays no wages. The business may or may not owe taxes for wages paid during an earlier period of time. This information may be used by the state systems to impute delinquent data for the unit's last quarter of activity. For instance, if an employer's End of Liability date is February 27th, but no data were reported for first quarter, March employment would be imputed as zero and the wages would be cut by approximately a third. This date will be used to track units on the LDB.

Caution: Some states' UI systems have several dates and status codes that identify different types of "no operations" in the state. These may include when the employer ceases to employ workers or pay wages, when the employer pays off all debts to the employment security agency, when the employer temporarily ceases operations during non-peak (non-seasonal times), etc. This field includes the date when the employer ceases to have employees or wages and does not anticipate reopening within the year. Do not use the later date of "inactive dates" or "end of liability dates." Use the date that identifies when the unit ceased to be active.

Note: If the unit's End of Liability date occurred during or after the reference quarter, the status code for the quarter would be active; if the End of Liability date were prior to the reference quarter, the status code would be inactive. If the End of Liability Date is the first day of the quarter but there is no employment or wages in the quarter, set the Status Code to inactive.

F

Fact of Discrepancy Information

(Required)

Fact of Discrepancy information are provided from BLS to the states identifying where there are discrepancies between comparable data fields of a record from what is on the state/BLS files and the information available from Census or other sources. The resulting information identifies how the state reviewed the problem and the outcome.

Fact of Discrepancy Year

(Required if any Fact of Discrepancies on the record is reported)

EQUI: Include Positions: 1113-1116
Frequency: Non-quarterly Field Length: 4 Type: Alphanumeric
Default Value: Blank Alternate Names: FoD Year
Source: BLS or state QCEW staff

Definition: Reference year in which BLS notified the state to resolve a Fact of Discrepancy or the year that the state made their determination about the record.

Note: If no action requested, the field is left blank.

Caution: To date, the Fact of Discrepancy Year has not been coded or maintained.

Fact of Discrepancy Month

(Required if any Fact of Discrepancies on the record is reported)

EQUI: Include Positions: 1117-1118
Frequency: Non-quarterly Field Length: 2 Type: Alphanumeric
Default Value: Blank Alternate Names: FoD Month
Source: BLS or state QCEW staff

Definition: Reference month in which BLS notified the state to resolve a Fact of Discrepancy or the month that the state made their determination about the record.

Note: If no action requested, the field is left blank.

Caution: To date, the Fact of Discrepancy Month has not been coded or maintained.

Fact of Discrepancy Control/Action Code

(Required if any Fact of Discrepancies on the record is reported)

EQUI: Include Positions: 1119-1120
Frequency: Non-quarterly Field Length: 2 Type: Alphanumeric
Default Value: Blank Alternate Names: FoD Action
Source: BLS or QCEW state staff

Definition: Control code from BLS explaining the type of discrepancy or the action code taken by the state to decide what the correct code was and if a change was or was not needed.

Note: If no action requested, the field is left blank.

Valid Values: TBD

Caution: To date, the Fact of Discrepancy Control/Action Code has not been coded or maintained.

Fact of Discrepancy NAICS

(Required if any Fact of Discrepancies on the record is reported)

EQUI: Include Positions: 1121-1126
Frequency: Non-quarterly Field Length: 6 Type: Alphanumeric
Default Value: Blank Alternate Names: FoD NAICS
Source: QCEW state staff

Definition: If a Fact of Discrepancy regarding the NAICS code existed between the state and alternate source, this field would include the NAICS code that the state determined was correct.

Note: If no action requested, the field is left blank.

Caution: To date, the Fact of Discrepancy NAICS has not been coded or maintained.

Fact of Discrepancy County

(Required if any Fact of Discrepancies on the record is reported)

EQUI: Include Positions: 1127-1129
Frequency: Non-quarterly Field Length: 3 Type: Alphanumeric
Default Value: Blank Alternate Names: FoD County
Source: State QCEW staff

Definition: If a Fact of Discrepancy regarding the county code existed between the state and alternate source, this field would include the county code that the state determined was correct.

Note: If no action requested, the field is left blank.

Caution: To date, the Fact of Discrepancy County has not been coded or maintained.

Fact of Discrepancy Explanation

(Required if any Fact of Discrepancies on the record is reported)

EQUI: Include Positions: 1130-1186
Frequency: Non-quarterly Field Length: 57 Type: Alphanumeric
Default Value: Blank Alternate Names: FoD Comment
Source: State QCEW staff

Definition: Narrative comment or explanation from the state clarifying their decision and actions regarding the discrepancy.

Note: If no action requested, the field is left blank.

Caution: To date, the Fact of Discrepancy Explanation has not been coded or maintained. Some states, however, with converted UI Account Numbers, retain the old UI numbers in the non-quarterly state use filed in their state system. These are transmitted to BLS in positions 1130-1165 of the EQUI file.

(QCEW Contact) Fax Number

(Required if available)

<u>EQUI:</u>	Include	<u>Positions:</u>	980-989
<u>Frequency:</u>	Non-quarterly	<u>Field Length:</u>	10 <u>Type:</u> Alphanumeric
<u>Default Value:</u>	Blank	<u>Alternate Names:</u>	Fax_area_cd, fax_phone, FX-AR, FAX

Format: Ten digits comprised of 3-digit area code, 3-digit prefix, and 4-digit suffix
Source: State UI system; QCEW staff (entered from MWR or ARS forms or from staff research), EDI, MWR Web, CARS

Definition: The fax telephone number for the employer. Preferably this is the fax number of the actual employer (not an agent), and it corresponds to the physical location of the establishment. The master record fax phone number should not be copied to subunits. Do not enter a 3-digit area code only, without the corresponding 7-digit number. Do not enter directory assistance number, (xxx) 555-1212. If the physical location fax telephone number is not available, a fax telephone number for another location or section of that employer would be preferable, e.g. the number of the corporate headquarters or central office, as opposed to the number for an outside payroll preparer or accounting firm.

Note: States are not required to enter this information.

Field Lock Position

(Optional in state systems)

<u>EQUI:</u>	Exclude	<u>Positions:</u>	N/A
<u>Frequency:</u>	Non-quarterly	<u>Field Length:</u>	2 <u>Type:</u> Numeric
<u>Default Value:</u>	Blank	<u>Alternate Names:</u>	Field Lock
<u>Source:</u>	QCEW staff		

Definition: Locking option to be used on the micro file to lock out updates/corrections to selected fields.

Valid Entries:

- 00 = No fields locked to update
- 01 = Physical Location Address locked
- 02 = Mailing/Other Address locked
- 04 = Legal Name locked
- 08 = Trade Name/DBA locked
- 16 = Telephone number locked
- 32 = Attention name locked

“01” and “02” will lock all fields of the physical location and mailing/other addresses.

Summations of these values indicate more than one type of change. For example, 03 means that both the Physical Location Address and Mailing Address are locked.

Caution: Note that while the Physical Location and Mailing/Other address fields can be locked, the UI address cannot be locked. All changes to the UI address are reported each quarter, preferably via an extract. If, however, the UI address is incorrect, the corrections are made to the UI tax file or source file and then sent to the micro file via an extract. If the UI address cannot be corrected via the tax file and it represents a more current and accurate address than the record has in its Mailing/Other address block, then the UI address is manually copied to the Mailing/Other address and corrected there. Alternatively, update the existing Mailing/Other address if the Mailing/Other address is not locked and if the mailing/other type code is 9 (unknown or other).

Example: If the UI address is extracted with no city, and if the UI tax file cannot be updated to add the city (e.g., Chicago), and the Mailing/Other address fields are blank, then enter the UI address with the correct city (Chicago) to the Mailing/Other address block. Determine if the UI address is a mailing address, corporate headquarters, or physical location and assign the appropriate Mailing/Other Address Type code. If the Address Type is unknown, code as “9.”

Format Type (Predecessor/Successor)

(Required)

<u>EQUI:</u>	Include, PS record	<u>Position:</u>	19		
<u>Frequency:</u>	Transaction	<u>Field Length:</u>	1	<u>Type:</u>	Alphanumeric
<u>Default Value:</u>	Blank	<u>Alternate Names:</u>			PS-Format
<u>Source:</u>	System-assigned, QCEW state staff				

Definition: Identifies if the UI Account/Reporting Unit Number is linked to a predecessor or a successor.

Valid Values:

- P = Predecessor
- S = Successor

Future ARS Refile Year

(Required if available)

<u>EQUI:</u>	Include	<u>Positions:</u>	808-811		
<u>Frequency:</u>	Non-quarterly	<u>Field Length:</u>	4	<u>Type:</u>	Numeric
<u>Default Value:</u>	Blank	<u>Alternate Names:</u>			Next First Quarter ARS Year
<u>Source:</u>	ARS Control File				

Definition: Refile year of the next refiling cycle if included in the current cycle. For instance, a record last refiled in 2015 may also be refiled in 2018. This field is blank on the EQUI if the record is not being refiled during the current fiscal year. The future ARS Refile Year does not exist in the EXPO or WIN micro files. This information is only on the control file in the state systems.

Future ARS Response Code

(Required if available)

<u>EQUI:</u>	Include	<u>Positions:</u>	812-813
<u>Frequency:</u>	Non-quarterly	<u>Field Length:</u>	2 <u>Type:</u> Numeric
<u>Default Value:</u>	Blank	<u>Alternate Names:</u>	Next First Quarter ARS Response Code

Source: ARS Control File

Definition: The information contained in this field is the ARS Response Code for the next first quarter EQUI file submittal if that record is included in the current refiling survey. For instance, a record is selected for inclusion in the FY 2018 ARS, and, based upon employer responses, is assigned an ARS Response Code of 41. If this same record was included three years earlier in the FY 2015 ARS and was assigned an ARS Response Code of 46 at that time, the “regular” ARS Response Code would be 46 (the response code from three years ago) through the 2017/4 EQUI file while the Future ARS Refile Year would be 2018 and the Future ARS Response Code would be 41. The ARS Response Code that would be used for this record during 2018/1 EQUI processing in national office would be 41 received as a result of the FY 2018 ARS. Response code 41 would now be the regular ARS Response Code on the record from the 2018/1 EQUI file through the 2020/4 file (assuming no changes occur and assuming the UI is refiled every three years).

Note: This field is blank on the EQUI if the record is not being refiled during the current fiscal year. The future ARS Refile Year does not exist in the EXPO or WIN micro files. This information is only on the control file in the state systems.

Future ARS NAICS Code

(Required if available)

<u>EQUI:</u>	Include	<u>Positions:</u>	814-819
<u>Frequency:</u>	Non-quarterly	<u>Field Length:</u>	6 <u>Type:</u> Numeric
<u>Default Value:</u>	Blank	<u>Alternate Names:</u>	Next First Quarter NAICS

Source: ARS Control File or the next first quarter micro file

Definition: Updated NAICS code expected for the next first quarter resulting from the current refiling survey. If the ARS Response Code is less than 41, leave the code blank. If the ARS Response Code is 41 or 42 set the Future ARS NAICS to the current quarter’s NAICS code. If the ARS Response Code is 46 or 50, include the Future ARS NAICS code of the pending code change that would be reflected in the first quarter data.

Note: This field is blank on the EQUI if the record is not being refiled during the current fiscal year. The Future ARS NAICS Code does not exist in the EXPO or WIN micro files. This information is only on the control file in the state systems.

Future ARS County Code

(Required if available)

<u>EQUI:</u>	Include	<u>Positions:</u>	820-822
<u>Frequency:</u>	Non-quarterly	<u>Field Length:</u>	3 <u>Type:</u> Numeric
<u>Default Value:</u>	Blank	<u>Alternate Names:</u>	Next First Quarter County
<u>Source:</u>	ARS Control File or the next first quarter micro file		

Definition: Updated county code expected for the next first quarter resulting from the current refiling survey. If the ARS Response Code is less than 41, leave the code blank. If the ARS Response Code is 41 or 42, set the Future ARS County Code to the current quarter's county code. If the ARS Response Code is 46 or 50, include the Future ARS County Code of the pending code change that would be reflected in the first quarter data.

Note: This field is blank on the EQUI if the record is not being refiled during the current fiscal year. The Future ARS County Code does not exist in the EXPO or WIN micro files. This information is only on the control file in the state systems.

Future ARS Township Code

(Required if available)

<u>EQUI:</u>	Include	<u>Positions:</u>	823-825
<u>Frequency:</u>	Non-quarterly	<u>Field Length:</u>	3 <u>Type:</u> Numeric
<u>Default Value:</u>	Blank	<u>Alternate Names:</u>	Next First Quarter Town
<u>Source:</u>	ARS Control File or the next first quarter micro file		

Definition: Updated township code expected for the next first quarter resulting from the current refiling survey. If the ARS Response Code is less than 41, leave the code blank. If the ARS Response Code is 41 or 42, set the Future ARS Township Code to the current quarter's township code. If the ARS Response Code is 46 or 50, include the Future ARS Township Code of the pending code change that would be reflected in the first quarter data.

Note: Town or township codes are assigned in New England states and New Jersey.

Note: This field is blank on the EQUI if the record is not being refiled during the current fiscal year. The Future ARS Township Code does not exist in the EXPO or WIN micro files. This information is only on the control file in the state systems.

Future ARS CMI Code

(Required if available)

<u>EQUI:</u>	Include	<u>Positions:</u>	826-827
<u>Frequency:</u>	Non-quarterly	<u>Field Length:</u>	2 <u>Type:</u> Numeric
<u>Default Value:</u>	Blank	<u>Alternate Names:</u>	Next First Quarter CMI
<u>Source:</u>	ARS Control File or the next first quarter micro file		

Definition: The information contained in this field is the ARS CMI Code for the next first quarter EQUI file submittal if that record is included in the current refiling survey.

Note: This field is blank on the EQUI if the record is not being refiled during the current fiscal year. The Future ARS CMI Code does not exist in the EXPO or WIN micro files. This information is only on the control file in the state systems.

Future Use

(Leave blank at this time)

<u>EQUI:</u>	Include	<u>Positions:</u>	1187-1190
--------------	---------	-------------------	-----------

Frequency: Not Determined Field Length: 4 Type: Alphanumeric/Numeric
Default Value: Blank Alternate Names: None
Source: N/A

Definition: Fields for future use. No other information is currently available.

G

Geocoding Software

(Required)

<u>EQUI:</u>	Include	<u>Position:</u>	738
<u>Frequency:</u>	Non-quarterly	<u>Field Length:</u>	1 <u>Type:</u> Alphanumeric
<u>Default Value:</u>	Blank	<u>Alternate Names:</u>	Geosoftware, SOFT,
<u>Source:</u>	State staff		

Definition: Single character designation of the software used to assign latitude and longitude. This field will be tied to the most recent location code and match code.

Valid Values: G = GeoStan, the software previously used by BLS

 blank = Web-based geocoding software from i/Lytics Innovative Systems

 S = Other state-used software

 Blank = if no latitude and longitude assigned

Geocode Source

(Required)

<u>EQUI:</u>	Include	<u>Position:</u>	739
<u>Frequency:</u>	Non-quarterly	<u>Field Length:</u>	1 <u>Type:</u> Alphanumeric
<u>Default Value:</u>	Blank	<u>Alternate Names:</u>	Geosource, geosource-cd, SRC
<u>Source:</u>	State staff		

Definition: Indicates where the latitude and longitude were originally assigned. Potential sources include: state QCEW unit, national office, or outside vendors. A default of blank is used when no latitude and longitude are assigned.

Valid Values: B = BLS assigned

 S = State assigned

 W = Web-based assignment (Global Innovative Systems)

 Blank = if no latitude and longitude assigned or other source

H

No Current Entries.

I

Initial Date of Liability

(Required)

<u>EQUI:</u>	Include	<u>Positions:</u>	520-527
<u>Frequency:</u>	Non-quarterly	<u>Field Length:</u>	8 <u>Type:</u> Numeric
<u>Default Value:</u>	Blank	<u>Alternate Names:</u>	Liability Date, Liab Date, init_liab_date, LIAB

Format: YYYYMMDD – four positions for year, two for month, and two for day (e.g., "20180401" for April 1, 2018)

Source: State UI system (for records with MEEI 1, 2, 4, or 6); system or QCEW staff assigned (for new worksite records – MEEI 3 or 5); QCEW staff (for federal reports), EDI, MWR Web system

Definition: This is the date that a new business became subject to UI reporting requirements. The date applies to single and master accounts and is assigned by UI. The date for worksites reported on the MWR or through the EDI Center is the date the subunit was first reported on the MWR or EDI transmission. When a new business begins operations for the first time and files an initial status determination form with the state (or becomes known to them by some other method), the employer is assigned an initial date of liability by the UI section. This date is available for single and master records (MEEI 1, 2, 4, or 6). For worksite records (MEEI 3 or 5), this preferably is the date of the first employment and wages that appear on the state system. As in the case of coding for the Set-up Date, it may not be possible to assign an accurate date to employers who have been active for an extended period; however, it is possible to assign reasonable dates to all new records. Once assigned, this date would not change for a continuous UI account or for a continuous establishment being reported via a MWR. This date is necessary to determine when the business (UI account) or establishment actually became liable under the UI laws and is typically (but not always) when the business began operations. This date will be used to track units on the LDB.

Note: If the unit is liable for even a single day, it is liable for the whole quarter.

J

No Current Entries.

K

No Current Entries.

L

Latitude

(Required)

EQUI: Include Positions: 747-755
Frequency: Twice (old and new) Field Length: 9 Type: Alphanumeric with decimal place
Default Value: Blank Alternate Names: Lat
Format: xx.xxxxxx
Source: Generated from the geocoding software

Definition: xx.xxxxxx format of the latitude (with two positions before the decimal place and six places after the decimal for accuracy). Include the decimal place in the format for the EQUI, listings, and screens.

Note: When a new latitude is assigned based on a change in the PLA data, shift the old latitude to the old latitude field and write the new latitude to the current latitude field.

Legal Name

(Required if available)

EQUI: Include Positions: 63-97
Frequency: Non-quarterly Field Length: 35 Type: Alphanumeric
Default Value: Blank Alternate Names: Legal/Corporate Name, legal_n, LGLNM
Format: Left justified
Source: State UI system; QCEW staff (for worksites); EDI Center (for worksites of centrally collected employers); ARS Web collected-data files; MWR Web collected-data files

Definition: Name of the reporting unit for legal purposes, both for single and multi-unit employers. Referred to as the Corporate Name in many systems. This element is usually extracted from the UI file thus using the definition of Legal Name as found in each state's tax system.

Special Criteria: Either the Legal Name or Trade Name **must** be present for each record. If both are available, both must be present.

Examples: The following examples show proper Trade and Legal Name configurations for both single unit and multi-unit employers.

For a single unit (MEEI=1, 4, or 6) with the Trade Name of Jim's Restaurant where the Legal Name is the same as the Trade Name, "Jim's Restaurant" appears in both name fields on the state system and the EQUI.

Trade Name: JIM'S RESTAURANT
 Legal Name: JIM'S RESTAURANT

If a single unit (MEEI=1, 4, or 6) has a Trade Name of Jack's Towing Service and a Legal Name of Jack Smith Enterprises, then "Jack's Towing Service" should appear in the Trade Name field, and "Jack Smith Enterprises" should appear in the Legal Name field.

Trade Name: JACK'S TOWING SERVICE
Legal Name: JACK SMITH ENTERPRISES

Suppose two multi subunits (MEEI=3 or 5) have unique Trade Names of Mike's Bar and Grill and Mike's Gas Station and they are both part of a multi-establishment employer whose Legal name is Mike Gray's Enterprises. Suppose further that this employer is not divided into divisions or subsidiaries. Each subunit record contains the unique Trade name for the subunit in the Trade Name field and "Mike Gray's Enterprises" in the Legal Name field.

(subunit 1)
Trade Name: MIKE'S BAR AND GRILL
Legal Name: MIKE GRAY'S ENTERPRISES

(subunit 2)
Trade Name: MIKE'S GAS STATION
Legal Name: MIKE GRAY'S ENTERPRISES

For multi subunits (MEEI=3 or 5), assume that the American Computer Corporation (Legal Name) is not organized into divisions or subsidiaries and has three subunits all with the Trade Name of Orange Computers. The subunit records on the micro and EQUI files all contain the Trade Name of "Orange Computers" and the Legal Name of "American Computer Corporation." Unique worksite identification, such as a store number, is reported in the Reporting Unit Description field, not in the Trade or Legal Name field.

(subunit 1)
Trade Name : ORANGE COMPUTERS
Legal Name : AMERICAN COMPUTER CORPORATION
R.U. Description: STORE NO. 1

(subunit 2)
Trade Name : ORANGE COMPUTERS
Legal Name : AMERICAN COMPUTER CORPORATION
R.U. Description: STORE NO. 2

(subunit 3)
Trade Name : ORANGE COMPUTERS
Legal Name : AMERICAN COMPUTER CORPORATION
R.U. Description: STORE NO. 3

For multi subunits (MEEI=3 or 5) that are not part of a subsidiary or separate division and where the Trade Name is the same as the Legal Name, both the Legal and Trade name fields on the EQUI and state system contain that name. For example, if a multi-establishment employer with a Legal Name of Smith Accounting Services has two subunits, all having the Trade Name of Smith Accounting Services, both the Trade Name field and the Legal Name field should contain

"Smith Accounting Services." Again, unique worksite identification is reported in the Reporting Description field.

(subunit 1)

Trade Name : SMITH ACCOUNTING SERVICES

Legal Name: : SMITH ACCOUNTING SERVICES

R.U. Description: BUSINESS AUDIT DIVISION

(subunit 2)

Trade Name : SMITH ACCOUNTING SERVICES

Legal Name: : SMITH ACCOUNTING SERVICES

R.U. Description: CORPORATE SERVICES DIVISION

Multi subunits (MEEI=3 or 5) that are part of a corporation organized into divisions or subsidiaries are reported with the Legal or Corporate Name of the multi-establishment employer in the Legal Name field and both the division subsidiary name and the trade name in the Trade Name field. For example, Francis Marlow Corporation has three divisions – the Restaurant division, the Hotel division, and the Condominium/Timeshare division. Chez Michele, Le Bistro, and Jacque's are three establishments in the Restaurant division. The record for Chez Michele should have "Francis Marlow Corporation" reported in the Legal Name field and "Restaurant Div. - Chez Michele" in the Trade Name field. Necessary abbreviations due to space restrictions are acceptable but every effort should be made to ensure that they are understandable.

(subunit 1)

Trade Name: RESTAURANT DIV. - CHEZ MICHELE

Legal Name: FRANCIS MARLOW CORPORATION

(subunit 2)

Trade Name: RESTAURANT DIV. - LE BISTRO

Legal Name: FRANCIS MARLOW CORPORATION

(subunit 3)

Trade Name: RESTAURANT DIV. - JACQUE'S

Legal Name: FRANCIS MARLOW CORPORATION

Location Code

(Required)

EQUI: Include Positions: 744-746
Frequency: Twice (old and new) Field Length: 3 Type: Alphanumeric
Default Value: Blank Alternate Names: LocCode, LOC, location-cd
Source: Geocoding software; BLS Geoload file

Definition: Explains the level of detail used to assign the geocode information as well as the qualities of the match—used to measure accuracy and reliability. According to the i/Lytics Innovative Systems documentation, “Address location codes detail the known qualities about the geocode.”

Valid Values are:

- E0** Not geocoded
- A1** Street Level - Record was geocoded to the rooftop level
- A2** Firm High-rise Point - Record was a firm/high-rise record and was assigned the latitude/longitude for the given firm/high-rise in the database
- A99** State assigned
- Z5** Record was geocoded to the ZIP centroid
- Z7** Record was geocoded to the ZIP + 2 centroid
- Z9** Record was geocoded to the ZIP + 4 centroid

Longitude

(Required)

EQUI: Include Positions: 756-766
Frequency: Twice (old and new) Field Length: 11 Type: Alphanumeric with sign and decimal place
Default Value: Blank Alternate Names: Long
Format: +/-xxx.xxxxxx
Source: Generated from the geocoding software

Definition: +/-xxx.xxxxxx format of the longitude where the first position is the direction, when positive no sign applied (blank instead of + sign), up to three positions can be used before the decimal place and six after. Include the decimal place in the format for the EQUI, listings, and screens.

Note: When a new longitude is assigned based on a change in the PLA date, shift the old longitude to the old longitude field and write the new longitude to the current longitude field.

M

Mailing/Other (M/O) Address Block

(Required if available)

The Mailing/Other address consists of a block of seven fields, and includes the Mailing/Other Address Type. These fields are described below. This address, if available, should be used for ARS mailings and MWR forms mailings to employers (or their agents), as well as missing data notices, and other correspondence. This address can be locked (as discussed for the [Field Lock Position](#)). Note: At least one complete address (either Physical Location, UI Address, or Mailing/Other Address), including all appropriate address lines, city, state, and zip information must appear on each record.

Caution: Few states have an address field on the UI tax file or related supplemental files that include specific mailing addresses. Mailing/Other address fields are not to be extracted from the UI tax file unless they are maintained and updated by UI on a regular basis. states use the Mailing/Other address fields to correct UI addresses. The Mailing/Other address fields can be locked.

Note: The Mailing/Other Address Block does not include either
Mailing/Other Address Foreign Country Code or
Mailing Other Address Foreign Postal Code.

Mailing/Other Address Line 1

(Required if available)

<u>EQUI:</u>	Include	<u>Positions:</u>	355-389
<u>Frequency:</u>	Non-quarterly	<u>Field Length:</u>	35
<u>Default Value:</u>	Blank, if all other fields in the Mailing/Other address block are blank	<u>Type:</u>	Alphanumeric
		<u>Alternate Names:</u>	Mailing/Other Address – Secondary Address Line, Mailing Address Line 1, MO- A1, mail_st1
<u>Format:</u>	Left justified		
<u>Source:</u>	QCEW staff		

Definition: First line of the mailing address for the reporting unit.

Note: If the street address and room, apartment, or suite number does not fit on one line, the street should be put in Address Line 1, while the room, apartment or suite number is put in Address Line 2.

System Action: If the Mailing/Other Address Line 1 is blank, but information is included on Mailing/Other Address Line 2, the state system moves it to Mailing/Other Address Line 1.

Mailing/Other Address Line 2

(Required if available)

EQUI: Include Positions: 390-424
Frequency: Non-quarterly Field Length: 35 Type: Alphanumeric
Default Value: Blank Alternate Names: Mailing/Other Address –
 Delivery Address Line,
 Mailing Address Line 2, MO-
 A2, mail_st2

Format: Left justified

Source: QCEW staff

Definition: Second line of the mailing address for the reporting unit. This is to include postal delivery information.

Note If the street address and room, apartment, or suite number does not fit on one line, the street should be put in Address Line 1, while the room, apartment or suite number is put in Address Line 2.

System Action: If the Mailing/Other Address Line 1 is blank, but information is included on Mailing/Other Address Line 2, the state system moves it to Mailing/Other Address Line 1.

Mailing/Other Address City

(Required if available)

EQUI: Include Positions: 425-454
Frequency: Non-quarterly Field Length: 30 Type: Alphanumeric
Default Value: Blank, if all other Alternate Names: Mailing Address City, MO-C1,
 fields in the mail_cty
 Mailing/Other address
 block are blank

Format: Left justified

Source: QCEW staff

Definition: City or town of the mailing address for the reporting unit. If the mailing/other address is located outside the United States, enter the city, a space, followed by the country abbreviation.

Valid Canadian province abbreviations are listed below:

Canadian Province Codes			
Province	Code	Province	Code
Alberta	AB	Nunavut	NU
British Columbia	BC	Ontario	ON
Manitoba	MB	Prince Edward Island	PE
New Brunswick	NB	Quebec	PQ
Newfoundland	NF	Saskatchewan	SK
Northwest Territory	NT	Yukon Territory	YT
Nova Scotia	NS		

Mailing/Other Address State

(Required if available)

EQUI: Include Positions: 455-456
Frequency: Non-quarterly Field Length: 2 Type: Alphabetic
Default Value: Blank, if all other fields in the Mailing/Other address block are blank Alternate Names: Mailing Address – State, MO-ST, mailst
Source: QCEW staff

Definition: Post Office state abbreviation of the mailing address for the reporting unit. For Canadian addresses, place “CN”. Other foreign locations should have “ZZ” in this field., in this field.

For military post offices, enter either AE, AA, or AP in this field as applicable.

Valid Values: The standard Post Office abbreviations for states appear in Appendix C. Other valid values are as follows:

Destination	Abbreviation
American Samoa	AS
Guam	GU
Military Post Offices in Central and South America (APO Miami)	AA
Military Post Offices in Canada, Europe, Africa, and the Middle East (APO New York)	AE
Military Post Offices in Pacific and some areas of Alaska (APO San Francisco)	AP
Canada	CN
All other foreign countries	ZZ

Mailing/Other Address ZIP Code

(Required if available)

EQUI: Include Positions: 457-461
Frequency: Non-quarterly Field Length: 5 Type: Alphanumeric
Default Value: Blank, if all other fields in the Mailing/Other address block are blank Alternate Names: Mailing Address – ZIP, MO-Z5, mail_zip
Source: QCEW staff

Definition: ZIP Code of the mailing address for the reporting unit.

Mailing/Other Address ZIP Code Extension

(Required if available)

<u>EQUI:</u>	Include	<u>Positions:</u>	462-465
<u>Frequency:</u>	Non-quarterly	<u>Field Length:</u>	4 <u>Type:</u> Alphanumeric
<u>Default Value:</u>	Blank	<u>Alternate Names:</u>	Mailing Address - ZIP Extension, Mailing/Other ZIP+4, MO-Z4, mail_ext

Format: Left justified. Place position 6 of a Canadian ZIP Code in the first position of this field, followed by three blanks.

Source: QCEW staff

Definition: ZIP Code Extension of the mailing address for the reporting unit. However, ZIP Code Extension is not essential; if all other mailing/other address fields exist but ZIP extension is missing, the address still passes the edits.

Mailing/Other Address Foreign Postal Code

<u>EQUI:</u>	Exclude	<u>Positions:</u>	
<u>Frequency:</u>	Non-quarterly	<u>Field Length:</u>	7 <u>Type:</u> Alphanumeric
<u>Default Value:</u>	Blank	<u>Alternate Names:</u>	

Format:

Source: State UI system

Definition: The postal code associated with the data in the Mailing/Other Address if the "Mailing/Other Address Foreign Country Code" field is available and out of country.

Note: EXPO, WIN-202, and the BLS processing system do not include this data element. This data element is included in the Standardized UI QUEST extract. This data element is only used for Canadian addresses. It populates the zip code field and the first position of the zip code expansion. This data element is to be left blank for addresses in Puerto Rico or the U.S. Virgin Islands.

Mailing/Other Address Type

(Required if the Mailing/Other Address block contains an address)

<u>EQUI:</u>	Include	<u>Position:</u>	466
<u>Frequency:</u>	Non-quarterly	<u>Field Length:</u>	1 <u>Type:</u> Numeric
<u>Default Value:</u>	9 if M/O Address is included, blank if M/O Address is blank	<u>Alternate Names:</u>	Address Type, AT, Mailing Address Type, MO-AT, mo_addr_ind

Source: QCEW staff (MWR, ARS, research), or system assigned default

Definition: Code that defines the type of address in the Mailing/Other Address block.

Valid Values:

- 1 = Physical address (physical and mailing address are the same)
- 2 = Mailing address (where the mail goes directly to the unit and may include the P.O. Box or RFD addresses)
- 3 = Corporate central office mail address
- 9 = Unknown blank – Mailing/Other address fields are blank

Users should only assign an Address Type of 1 if this physical location address conforms to postal regulations as a mailable address.

System Action: If 1 is assigned in this field, the state system includes a copy of the Physical Location Address to the Mailing/Other Address.

Match Code

(Required on records with latitude and longitude)

<u>EQUI:</u>	Include	<u>Positions:</u>	740-743
<u>Frequency:</u>	Non-quarterly	<u>Field Length:</u>	4
<u>Default Value:</u>	Blank	<u>Alternate Names:</u>	Alphanumeric MATCH, Address process code, match-cd, old-match-cd

Definition: Match codes are status information generated from the i/Lytics Post Locate Innovative Systems software that identifies the extent to which the software was able to match the address information to a latitude and longitude or if it was unable to make any kind of match. Information on the first position is listed below.

Valid Values:

- SS** Success. Single candidate returned from the database
- EW** Record matched to an entry in the Early Warning System (EWS) file
- LC** The record was not matched to the zip+4 database, but was converted to a ZIP+4 coded address using the *Locatable Address Conversion System*
- IC** Input city/postal code not found in database. Lookup failed.
- IS** The street name was not found in the database. Lookup failed.
- MH** Multiple possible candidates in database. Lookup failed.
- NC** No city/state or postal code found. . Lookup failed.
- NH** No candidate records in the database. Lookup failed.
- SC** The street name was not found for the city name entered. Lookup failed.
- SH** The house number does not exist for the street name entered. Lookup failed.
- UZ** Record has a ZIP Code flagged as unique but address did not match in database. Lookup failed.
- ZM** Record matched entry in ZIP Move file, but did not match new ZIP Code. Lookup failed.

Maximum Reporting Unit Number

(Derived in state systems)

<u>EQUI:</u>	Include	<u>Positions:</u>	563-567
<u>Frequency:</u>	Non-quarterly	<u>Field Length:</u>	5
<u>Default Value:</u>	Blank	<u>Alternate Names:</u>	Numeric Highest Worksite Number; Highest RUN, Highest Reporting Unit Number, max_run, MAXRU

Format: Right justified, with unused positions zero-filledSource: System generated

Definition: The largest Reporting Unit Number ever used or assigned to the unit's UI Account Number. If the account is a single establishment and was never a multi-establishment, the Maximum Reporting Unit Number is "00000." If a master unit converts to a single establishment (collapsed multi), this field would include the Maximum Reporting Unit Number of a worksite that is either no longer on the state system or inactive on the state system. The Maximum Reporting Unit Number may be higher than any active existing Reporting Unit Number due to active, inactive, sold or out of business reporting units.

Valid Values: Numbers less than 99999.

Example: A group of multi-establishments has six units with "00006" as the highest reporting unit number assigned. If unit "00006" is closed, the Maximum Reporting Unit Number remains

at “00006”. If a new unit is established, that new unit would be assigned “00007” and the maximum reporting unit number would also be changed to “00007”.

Caution: This field is included in the systems to help ensure that reporting unit numbers are not reused. See Reporting Unit Number for additional details.

Monthly Employment and Monthly Employment Indicators

(Required)

There are three monthly employment fields, one for each month of the quarter. Each employment field is associated with an employment indicator flag that identifies the source of the data.

First Month Employment

(Required)

<u>EQUI:</u>	Include	<u>Positions:</u>	606-611
<u>Frequency:</u>	Quarterly	<u>Field Length:</u>	6 <u>Type:</u> Numeric
<u>Default Value:</u>	None	<u>Alternate Names:</u>	Month One Employment, M1, Emp1, (January, April, July, October), m1 emp, MON1

Format: Right justified with leading zeros

Source: State UI system (for single and master records); QCEW staff (for worksites, federal records); EDI Center (for worksites of centrally collected employers); or system generated (for imputed data); MWR Web collection systems

Definition: The monthly employment data, which may be reported on the Quarterly Contribution Report, Multiple Worksite Report, the Report of Federal Employment and Wages (RFEW), or electronically. This is a count of all full-time and part-time workers who worked during or received pay (subject to Unemployment Insurance taxes) for the pay period that includes the 12th day of the first month of the reference quarter. If there is no first month employment, zero-fill the entire field. The count is unduplicated, so an employee is counted only once in any month by a given employer.

Rounding Criteria: To the nearest whole number.

System Action: The state system imputes the employment when it is not reported, as appropriate (see First Month Employment Indicator Flag).

First Month Employment Indicator Flag

(Required)

<u>EQUI:</u>	Include	<u>Position:</u>	612
<u>Frequency:</u>	Quarterly	<u>Field Length:</u>	1 <u>Type:</u> Alphanumeric

<u>Default Value:</u>	M	<u>Alternate Names:</u>	Imputed Employment Flag, Estimated Employment Flag, Month 1 Indicator, m1 emp_ind, MON1I
-----------------------	---	-------------------------	--

Source: System generated (blank, K, M, N, P, R, E, X, and S) for all data entered via extract or batch or from an imputation routine. Also on the IMT. QCEW staff (other values).

Definition: Indicator showing how the employment data were obtained. Data must be imputed, prorated or aggregated if: 1) the Quarterly Contribution Report is delinquent; or 2) the Quarterly Contribution Report has been submitted with wage data but without employment data, and follow-up to obtain the missing data is unsuccessful; or 3) the Quarterly Contribution Report is submitted for a multi-establishment employer but the MWR is not; or 4) the MWR is submitted but the Quarterly Contribution Report is not.

Valid Values:

Blank or R = reported data
 A = estimated from CES report
 C = changed (re-reported)
 D = reported from missing data notice
 E = imputed single unit employment or imputed worksite employment prorated from imputed parent record
 H = hand-imputed (not system generated)
 K = special system-generated imputation to reflect data impacted by a catastrophe
 L = late reported (overrides prior imputation)
 M = missing data
 N = zero-filled pending resolution of long-term delinquent reporter
 P = prorated from reported master to worksite
 S = aggregated master from reported MWR or EDI data
 W = estimated from wage record employment
 X = non-numeric employment zero-filled pending further action

Note: The state needs to resolve all "X" records before submission on the EQUI.

Caution: Imputed data on the UI tax file should not be copied or extracted to QCEW micro files.

Second Month Employment

(Required)

<u>EQUI:</u>	Include	<u>Positions:</u>	613-618
<u>Frequency:</u>	Quarterly	<u>Field Length:</u>	6 <u>Type:</u> Numeric
<u>Default Value:</u>	None	<u>Alternate Names:</u>	Month Two Employment, M2, Emp2, (February, May, August, November), m2emp, MON2

Format: Right justified with leading zeros

Source: State UI system (for single and master records); QCEW staff (for worksites, federal records); EDI Center (for worksites of centrally collected employers); or system generated (for imputed data), MWR Web collection systems

Definition: The monthly employment data, which may be reported on the Quarterly Contribution Report, Multiple Worksite Report, the Report of Federal Employment and Wages (RFEW), or electronically. This is a count of all full-time and part-time workers who worked during or received pay (subject to Unemployment Insurance taxes) for the pay period that includes the 12th day of the second month of the reference quarter. If there is no second month

employment, zero-fill the entire field. The count is unduplicated, so an employee is counted only once in any month by a given employer.

System Action: The state system imputes the employment when it is not reported, as appropriate (see Second Month Employment Indicator Flag).

Second Month Employment Indicator Flag

(Required)

<u>EQUI</u> :		<u>Position</u> :	619	
<u>Frequency</u> :	Quarterly	<u>Field Length</u> :	1	<u>Type</u> : Alphanumeric
<u>Default Value</u> :	M	<u>Alternate Names</u> :	Imputed Employment Flag, Estimated Employment Flag, Month 2 Indicator, m2emp_ind, MON2I	

Source: System generated (blank, K, M, N, P, R, E, X, and S) for all data entered via extract or batch or from an imputation routine. IMT QCEW staff (other values).

Definition: Indicator showing how the employment data were obtained. Data must be imputed, prorated or aggregated if: 1) the Quarterly Contribution Report is delinquent; or 2) the Quarterly Contribution Report has been submitted with wage data but without employment data, and follow-up to obtain the missing data is unsuccessful; or 3) the Quarterly Contribution Report is submitted for a multi-establishment employer but the MWR is not; or 4) the MWR is submitted but the Quarterly Contribution Report is not.

Valid Values:

- Blank or R = reported data
- A = estimated from CES report
- C = changed (re-reported)
- D = reported from missing data notice
- E = imputed single unit employment or imputed worksite employment prorated from imputed parent record
- H = hand-imputed (not system generated)
- K = special system-generated imputation to reflect data impacted by a catastrophe
- L = late reported (overrides prior imputation)
- M = missing data
- N = zero-filled pending resolution of long-term delinquent reporter
- P = prorated from reported master to worksite
- S = aggregated master from reported MWR or EDI data
- W = estimated from wage record employment
- X = non-numeric employment zero-filled pending further action

Note: The state needs to resolve all "X" records before submission on the EQUI.

Caution: Imputed data on the UI tax file should not be copied or extracted to QCEW micro files.

Third Month Employment

(Required)

EQUI:	Include	Positions:	620-625
Frequency:	Quarterly	Field Length:	6 Type: Numeric
Default Value:	None	Alternate Names:	Month Three Employment, M3, Emp3, (March, June, September, December), m3emp, MON3

Format: Right justified with leading zeros

Source: State UI system (for single and master records); QCEW staff (for worksites, federal records); EDI Center (for worksites of centrally collected employers); or system generated (for imputed data), MWR Web collection systems, IMT

Definition: The monthly employment data, which may be reported on the Quarterly Contribution Report, Multiple Worksite Report, the RFEW, or electronically. This is a count of all full-time and part-time workers who worked during or received pay (subject to Unemployment Insurance taxes) for the pay period that includes the 12th day of the third month of the reference quarter. If there is no third month employment, zero-fill the entire field. The count is unduplicated, so an employee is counted only once in any month by a given employer.

System Action: The state system needs to impute the employment when it is not reported, as appropriate (see Third Month Employment Indicator Flag).

Third Month Employment Indicator Flag

(Required)

<u>EQUI:</u>		<u>Position:</u>	626
<u>Frequency:</u>	Quarterly	<u>Field Length:</u>	1
<u>Default Value:</u>	M	<u>Alternate Names:</u>	Type: Alphanumeric Imputed Employment Flag, Estimated Employment Flag, Month 3 Indicator, m3emp_ind, MON3I

Source: System generated (blank, K, M, N, P, R, E, X, and S) for all data entered via extract or batch or from an imputation routine, IMT, QCEW staff (other values).

Definition: Indicator showing how the employment data were obtained. Data must be imputed, prorated or aggregated if: 1) the Quarterly Contribution Report is delinquent; or 2) the Quarterly Contribution Report has been submitted with wage data but without employment data, and follow-up to obtain the missing data is unsuccessful; or 3) the Quarterly Contribution Report is submitted for a multi-establishment employer but the MWR is not; or 4) the MWR is submitted but the Quarterly Contribution Report is not.

Valid Values:

- Blank or R = reported data
- A = estimated from CES report
- C = changed (re-reported)
- D = reported from missing data notice
- E = imputed single unit employment or imputed worksite employment prorated from imputed parent record
- H = hand-imputed (not system generated)
- K = special system-generated imputation to reflect data impacted by a catastrophe
- L = late reported (overrides prior imputation)
- M = missing data
- N = zero-filled pending resolution of long-term delinquent reporter
- P = prorated from reported master to worksite
- S = aggregated master from reported MWR or EDI data
- W = estimated from wage record employment
- X = non-numeric employment zero-filled pending further action

Note: The state needs to resolve all "X" records before submission on the EQUI.

Caution: Imputed data on the UI tax file should not be copied or extracted to QCEW micro files.

Multi Establishment Employer Indicator

(Required)

<u>EQUI:</u>	Include	<u>Position:</u>	660
<u>Frequency:</u>	Quarterly	<u>Field Length:</u>	1 <u>Type:</u> Numeric
<u>Default Value:</u>	None	<u>Alternate Names:</u>	MEEI, MEEI Code, meei_cd
<u>Source:</u>	QCEW staff ; copied from previous quarter if unchanged on state system		

Definition: Code that distinguishes between records for single units, multi-unit master records, and subunits of a multi-establishment employer.

Valid Values:

- 1 = Single establishment unit
- 2 = Multi-unit master record
- 3 = Subunit establishment level record for a multi-unit employer
- 4 = Multi-establishment employer reporting as a single unit due to unavailability of data, including refusals
- 5 = A subunit record that actually represents a combination of establishments; finer level breakouts are not yet available
- 6 = Known multi establishment employer reporting as a single unit and not solicited for disaggregation because of small employment (< 10) in all secondary establishments combined

For every multi-unit employer, the state's system and EQUI file contain at least three records (the master and at least two subunits). The master unit represents the administrative (UI accounting) aggregation of all subunits under that UI Account Number and should not be confused with the primary establishment, which is evaluated along with secondary establishment(s) to determine multi-unit status. At least two active subunits (representing at least two establishments) must be associated with the master record UI account number. If there is only one active subunit, then the account has been misidentified and is reclassified as a single unit. If a multi-establishment employer becomes a single establishment employer, the record for the out-of-business or sold subunit is inactivated, the record for the remaining establishment is also inactivated, and the MEEI code of the master record should be changed from "2" to "1." That record (the record with RUN 00000) is used to report the data for the one remaining establishment. See Sections 5.5 and 5.6 for additional information on multi-unit breakouts and collapses.

Also note the difference between MEEI code "4" and "6." As stated earlier, an MEEI of "6" indicates that the establishments in question do not meet the employment size criterion for disaggregating a multi-unit employer. On the other hand, the MEEI of "4" indicates that the employer does meet the employment criterion, but is unable or unwilling to provide employment and wage data at the establishment level. Employers with MEEI codes of "4" are solicited periodically to see if employment and wage data can be reported at the establishment level. Employers coded as MEEI "6" may be solicited as resources permit.

MWR Mail Indicator

(Required if available)

<u>EQUI:</u>	Include	<u>Position:</u>	568		
<u>Frequency:</u>	Quarterly	<u>Field Length:</u>	1	<u>Type:</u>	Numeric
<u>Default Value:</u>	Blank	<u>Alternate Names:</u>	<u>MA-CD, mwr-mail-ind</u>		
<u>Source:</u>	QCEW staff, EDI load, MWR Web load				

Definition: Identifies whether or not a MWR form should be mailed to the respondent.

Valid Values: EXPO and WIN specific

Caution: Both EXPO and WIN default the value to “mailing MWR” even on single accounts.

The field is used in conjunction with the MEEI code. Only accounts with MEEI 2 and this value are sent a form.

N

NAICS Code

(Required if available)

<u>EQUI:</u>	Include	<u>Positions:</u>	591-596
<u>Frequency:</u>	Quarterly	<u>Field Length:</u>	6 <u>Type:</u> Numeric
<u>Default Value:</u>	999999	<u>Alternate Names:</u>	Organization NAICS, Link NAICS, naics-cd

Source: System transferred from ARS Control File in first quarter; copied from previous quarter if unchanged in state system, EDI for new units and successor records, MWR Web collection for comparable new units, QCEW staff (for worksites, economic changes); state UI system (new records)

Definition: NAICS (North American Industry Classification System) codes are uniform industrial codes used by the United States, Canada, and Mexico to identify the primary activity of an establishment. The NAICS code uses the NAICS Manual definitions for the handling of auxiliary establishments, in which each establishment is classified **based on its own activities**.

Valid Values: Six-digit NAICS codes, as defined by the 2017 NAICS code.

Caution: This field should not be extracted from the UI tax file except for new records.

NAICS12

(Blank for all records unless notified otherwise)

<u>EQUI:</u>	Include as blank	<u>Positions:</u>	585-590
<u>Frequency:</u>	Quarterly	<u>Field Length:</u>	6 <u>Type:</u> Numeric
<u>Default Value:</u>	Blank	<u>Alternate Names:</u>	NAICS-2012 code

For 2017/1, set by the state systems to the NAICS-2012 code in 2016/4, blank for new records

Source: For the revision to NAICS-2017, the state systems copied the 2016/4 NAICS code into this (NAICS12) field for 2017/1.

Definition: For 2017/1, this field holds the 2016/4 NAICS-2012 based NAICS code. Though quarterly, the 2017/1 value in this field will not roll forward and it should be blank for 2017/2 and subsequent quarters. For new records started 1/1/2017 or later, this field will be blank in all quarters, including 2017/1.

Valid Values: 2012-based NAICS codes

Caution: Until the revision to NAICS-2017, this field had been named “NAICS07”, having been used in the last (NAICS-2012) revision and repurposed for the NAICS-2017 revision.

Narrative Comment

(Required if applicable)

<u>EQUI:</u>	Include	<u>Positions:</u>	668-724
<u>Frequency:</u>	Quarterly	<u>Field Length:</u>	57 <u>Type:</u> Alphanumeric
<u>Default Value:</u>	Blank	<u>Alternate Names:</u>	com_narr
<u>Format:</u>	Left justified		
<u>Source:</u>	QCEW staff; EDI Center (for worksites of centrally collected employers); MWR Web collection system, MWR form		

Definition: A field used to provide an explanation for any unique changes in an establishment that cannot be accounted for through the standard QCEW comment codes. State staff are encouraged to include more details in the narrative comment field if the record is very large or the change was significant.

Special Criteria: If narrative comment field is included, the comment code 99 or at least one valid comment code must appear on the micro file record.

Note: This field is 57 positions. State staff should attempt to use reasonable abbreviations to ensure that they include the useful information without it being truncated.

Nondisclosure/Informed Consent Code

(Optional use in state)

<u>EQUI:</u>	Include	<u>Position:</u>	799
<u>Frequency:</u>	Non-quarterly	<u>Field Length:</u>	1 <u>Type:</u> Alphanumeric
<u>Default Value:</u>	Blank	<u>Alternate Names:</u>	<u>Informed Consent Code,</u> <u>ICCD, consent-cd</u>
<u>Format:</u>	Right justified with leading zeros		
<u>Source:</u>	Assigned by the state based on receipt of an informed consent form from the employer or the end of an informed consent period previously approved by the employer.		

Definition: The Nondisclosure/Informed Consent Code identifies if the state and the employer have established a written understanding and agreement that selected data information may be released either as micro data from the respondent or with selected macro aggregations including data from the respondent even though data users may be able to identify confidential information about the employer and its business.

Valid Values: To be determined at a later date.

Nondisclosure/Informed Consent Year Agreed

(Optional use in state)

<u>EQUI:</u>	Include	<u>Positions:</u>	800-803
<u>Frequency:</u>	Non-quarterly	<u>Field Length:</u>	4 <u>Type:</u> Numeric
<u>Default Value:</u>	Blank	<u>Alternate Names:</u>	<u>Consent initial year, consent-init-yr, Informed Consent Start Year, ICST</u>

Format: YYYY

Source: Assigned by the state based on receipt of an informed consent form from the employer or the end of an informed consent period previously approved by the employer.

Definition: The Nondisclosure/Informed Consent Year is the beginning reference year that the state has been provided with permission to potentially release either selected micro data from the respondent or selected macro aggregations including data from the respondent even though data users may be able to identify confidential information about the employer and its business. This is not the date of the agreement but the year of the reference data that may be released.

Nondisclosure/Informed Consent Year Ended

(Optional use in state)

<u>EQUI:</u>	Include	<u>Positions:</u>	804-807
<u>Frequency:</u>	Non-quarterly	<u>Field Length:</u>	4 <u>Type:</u> Numeric
<u>Default Value:</u>	Blank	<u>Alternate Names:</u>	<u>Consent end year, consent-end-yr, Informed Consent End Year, ICEND</u>

Format: YYYY

Source: Assigned by the state based on receipt of an informed consent form from the employer or the end of an informed consent period previously approved by the employer.

Definition: The Nondisclosure/Informed Consent Year is the ending reference year that the state has been provided with permission to potentially release either selected micro data from the respondent or selected macro aggregations including data from the respondent even though data users may be able to identify confidential information about the employer and its business.

O

Old County

(Required for a county change when a noneconomic code change is present)

<u>EQUI:</u>	Include	<u>Positions:</u>	552-554
<u>Frequency:</u>	Non-quarterly	<u>Field Length:</u>	3 <u>Type:</u> Numeric
<u>Default Value:</u>	Blank	<u>Alternate Names:</u>	OCTY
<u>Source:</u>	ARS Control File (system transferred), or QCEW staff when applying code changes directly to the micro file, derived in WIN		

Definition: A data element used to identify a noneconomic code change to the County code. If the County code for the first quarter reference period (e.g., first quarter 2018 for the FY 2018 refiling) is different than the County code used to report that establishment's data in the preceding fourth quarter (e.g., fourth quarter 2017) then the micro file should include an Old County code – provided the change is noneconomic. The Old County code normally equals the record's county code when the ARS Control File was created during the preceding first quarter (e.g., first quarter 2017). In special circumstances (e.g., a new multi-establishment breakout), certain predecessor/successor situations, the Old County is set equal to the fourth quarter County code of a different record.

System Action: The state system is used to transfer certain information from the Control File to the micro file during first quarter processing. For each record on the Control File, the state systems transfer the Old fields from the Control File to the Old fields in the non-quarterly occurrence portion of the matching micro file record. Meanwhile the system assigns the Control File's New field, if valid and different from the Old, to the equivalent first quarter classification code of the micro file record. The ARS Response Code and ARS Refile Year will also be passed from the Control File to the micro file at the same time. If the Old field differs from the equivalent code in fourth quarter, and if the fourth quarter code is valid, and if the fourth quarter was active, then the state system sets the Old field on the micro file equal to the fourth quarter code.

Valid Values: Valid FIPS County codes for the state plus the following county equivalent codes:

- 995 = Statewide with no primary county
- 996 = Foreign locations
- 998 = Out-of-state locations
- 999 = Unknown locations

Caution: Old fields are copied from the ARS Control File, not from the UI tax file. If Old fields are not retained on the Control File, the Old fields should equal the corresponding fourth quarter codes on the micro file.

Old NAICS

(Required for a NAICS change when a noneconomic code change is present)

<u>EQUI:</u>	Include	<u>Positions:</u>	569-574
<u>Frequency:</u>	Non-quarterly	<u>Field Length:</u>	6 <u>Type:</u> Numeric
<u>Default Value:</u>	Blank	<u>Alternate Names:</u>	ONAIICS
<u>Source:</u>	ARS Control File (system transferred), or QCEW staff when applying code changes directly to the micro file, derived in WIN		

Definition: A data element used to identify a noneconomic code change to the NAICS code. If the NAICS code for the first quarter reference period (e.g., first quarter 2018 for the FY2018 refiling) is different than the NAICS code used to report that establishment's data in the preceding fourth quarter (e.g., fourth quarter 2017) then the micro file should include an Old NAICS – provided the change is noneconomic. The Old NAICS code normally equals the record's NAICS code when the ARS Control File was created during the preceding first quarter (e.g., first quarter 2017). In special circumstances (e.g., a new multi-establishment breakout), the Old NAICS may be set equal to the fourth quarter NAICS code of a different record.

System Action: The state system is used to transfer certain information from the Control File to the micro file during first quarter processing. For each record on the Control File, the state systems transfer the Old fields from the Control File to the Old fields in the non-quarterly occurrence portion of the matching micro file record. Meanwhile the system assigns the Control File's New field, if valid and different from the Old, to the equivalent first quarter classification code of the micro file record. The ARS Response Code and ARS Refile Year will also be passed from the Control File to the micro file at the same time. If the Old field differs from the equivalent code in fourth quarter, and if the fourth quarter code is valid, and if the fourth quarter was active, then the state system sets the Old field on the micro file equal to the fourth quarter code.

Valid Values: Six-digit NAICS codes, as defined in the 2017 North American Industry Classification System manual.

Caution: Old fields are copied from the ARS Control File, not from the UI tax file. If Old fields are not retained on the Control File, the Old fields should equal the corresponding fourth quarter codes on the micro file.

Old Ownership

(Required for an ownership change when a noneconomic code change is present)

<u>EQUI:</u>	Include	<u>Position:</u>	555
<u>Frequency:</u>	Non-quarterly	<u>Field Length:</u>	1 <u>Type:</u> Numeric
<u>Default Value:</u>	Blank	<u>Alternate Names:</u>	Old Own, OOWN
<u>Source:</u>	ARS Control File (system transferred), or QCEW staff when applying code changes directly to the micro file, derived in WIN		

Definition: A data element used to identify a noneconomic code change to the Ownership code. If the Ownership code for the first quarter reference period (e.g., first quarter 2018 for the FY 2018 refiling) is different than the Ownership code used to report that establishment's data in the preceding fourth quarter (e.g., fourth quarter 2017) then the micro file should include an Old Ownership code – provided the change is noneconomic. The Old Ownership code normally equals the record's Ownership code when the ARS Control File was created during the preceding first quarter (e.g., first quarter 2017). In special circumstances (e.g., certain predecessor/successor situations), the Old Ownership is set equal to the fourth quarter Ownership code of a different record.

System Action: The state system is used to transfer certain information from the Control File to the micro file during first quarter processing. For each record on the Control File, the state systems transfer the Old fields from the Control File to the Old fields in the non-quarterly occurrence portion of the matching micro file record. Meanwhile the system assigns the Control File's New field, if valid and different from the Old, to the equivalent first quarter classification code of the micro file record. The ARS Response Code and ARS Refile Year will also be passed from the Control File to the micro file at the same time. If the Old field differs from the equivalent code in fourth quarter, and if the fourth quarter code is valid, and if the fourth quarter was active, then the state system sets the Old field on the micro file equal to the fourth quarter code.

Valid Values:

- 1 = Federal government
- 2 = State government
- 3 = Local government
- 5 = Private sector

Caution: Old fields are copied from the refiling Control File, not from the UI tax file. If Old fields are not retained on the Control File, the Old fields should equal the corresponding fourth quarter codes on the micro file.

Old Township

(For New England states and New Jersey, required for a geographic (County/Township) change when a noneconomic code change is present.)

EQUI:	Include	Positions:	560-562
Frequency:	Non-quarterly	Field Length:	3
Default Value:	Blank	Type:	Numeric
Source:	ARS Control File (system transferred), or QCEW staff when applying code changes directly to the micro file, derived in WIN		
		Alternate Names:	Old Town, OTOWN

Definition: For certain states, a data element used to identify a noneconomic code change to the Township code. If the Township code for the first quarter reference period (e.g., first quarter 2018 for the FY 2018 refiling) is different than the Township code used to report that establishment's data in the preceding fourth quarter (e.g., fourth quarter 2017) then the micro file should include an Old Township code – provided the change is noneconomic. The Old Township code normally equals the record's Township code when the ARS Control File was created during the preceding first quarter (e.g., first quarter 2017). In special circumstances (e.g., a new multi-establishment breakout, certain predecessor/successor situations), the Old Township is set equal to the fourth quarter Township code of a different record.

System Action: The state system is used to transfer certain information from the Control File to the micro file during first quarter processing. For each record on the Control File, the state

systems transfer the Old fields from the Control File to the Old fields in the non-quarterly occurrence portion of the matching micro file record. Meanwhile the system assigns the Control File's New field, if valid and different from the Old, to the equivalent first quarter classification code of the micro file record. The ARS Response Code and ARS Refile Year will also be passed from the Control File to the micro file at the same time. If the Old field differs from the equivalent code in fourth quarter, and if the fourth quarter code is valid, and if the fourth quarter was active, then the state system sets the Old field on the micro file equal to the fourth quarter code.

Valid Values: Valid FIPS Township codes for the state plus the following Township equivalent codes:

- 995 = Statewide with no primary township
- 996 = Foreign locations
- 998 = Out-of-state locations
- 999 = Unknown locations

Caution: Old fields are copied from the refiling Control File, not from the UI tax file. If Old fields are not retained on the Control File, the Old fields should equal the corresponding fourth quarter codes on the micro file.

Note: This data element is only used for states required to report Township codes: the New England states and New Jersey. These states enter Old Township in combination with Old County. If Old fields are not retained on the Control File, the Old fields should equal the corresponding fourth quarter codes on the micro file.

Organization Type Indicator

(Required if available)

<u>EQUI:</u>	Include	<u>Position:</u>	598
<u>Frequency:</u>	Non-quarterly	<u>Field Length:</u>	1
<u>Default Value:</u>	Blank	<u>Type:</u>	Alphanumeric
<u>Source:</u>	State UI system; QCEW staff	<u>Alternate Names:</u>	Org Type, ORG, org_typ_cd

Definition: The legal form of the organization used for tax purposes by the establishment. It is valid for the private sector (Ownership code 5) only. This code is used on Initial Status Determination Forms to solicit information from private sector establishments concerning their organizational structure.

Valid Vales: I = Individual
P = Partnership
C = Corporation
O = Other

System Action: When this indicator is assigned to a master record in a multi-unit account, the state system copies the indicator from the master record to the subunit records in the same UI account.

Caution: Several state tax systems collect a limited number of organization types from the Status Determination Forms. These should be reviewed and converted to the standardized codes listed above. Blank-fill for Ownership Codes of 1, 2, and 3. In states where Organization Codes are not used, leave the field blank.

Ownership Code

(Required)

<u>EQUI:</u>	Include	<u>Position:</u>	597
<u>Frequency:</u>	Quarterly	<u>Field Length:</u>	1 <u>Type:</u> Numeric
<u>Default Value:</u>	None	<u>Alternate Names:</u>	Own, own_cd, OWN1
<u>Source:</u>	State UI system; QCEW staff (including Federal accounts); copied from previous quarter if unchanged on state system; system-transferred from the ARS Control File in first quarter; EDI Center (for birth records of centrally collected employers), MWR Web collection for births		

Definition: A one-position field showing the legal proprietorship of the enterprise and describing the economic ownership of the enterprise.

Valid Values:

- 1 = Federal government
- 2 = State government
- 3 = Local government
- 5 = Private sector (includes both domestic and foreign-owned units)

System Action: When this code is assigned to a master record in a multi-unit account, the state system copies the code from the master record to the subunit records in the same UI account.

Ownership Extension

(Optional in EXPO)

<u>EQUI:</u>	Exclude	<u>Position:</u>	N/A
<u>Frequency:</u>	Quarterly	<u>Field Length:</u>	1 <u>Type:</u> Alphanumeric
<u>Default Value:</u>	Zero	<u>Alternate Names:</u>	None
<u>Source:</u>	Derived from UI tax file status codes; QCEW Staff; system assigned		

Definition: A one-position field for use as an optional extension to the Ownership code. Some states have state-specific codes for subdivisions of the private sector and may place them in this field.

Example: In a few states, the second digit of the two-digit ownership code includes information on different types of partnerships (e.g., limited partnerships or limited liability partnerships) or corporations (e.g., non-profit corporation, in-state corporation, or out-of-state corporations), or other information on estates, associations, cooperatives, etc.

Caution: States are encouraged to report this information in the Organization Type Indicator.

P

PEO Client Information from EDI or other sources

The following information is collected via the EDI centers or other central collection on Professional Employer Organizations (PEO), formerly referred to as Employee Leasing Companies.

PEO Client UI Account Number

(Provided by EDI for PEO units)

<u>EQUI:</u>	Exclude	<u>Positions:</u>	N/A
<u>Frequency:</u>	Non-quarterly	<u>Field Length:</u>	10 <u>Type:</u> Numeric
<u>Default Value:</u>	blank	<u>Alternate Names:</u>	None
<u>Source:</u>	Provided by EDI system for PEO units (record type 3 of the EDI format)		

Definition: The ten-digit value of the original client account. This information is transferred from the EDI load file to the predecessor UI number field of the record. This information should be written to the unit's predecessor UI Account Number. Zero-fill the predecessor reporting unit number in these cases.

Note: See Appendix N – MWR File Layouts for the EDI format.

PEO Client Employer Identification (EI) Number

(Provided by EDI for PEO units)

<u>EQUI:</u>	Exclude	<u>Positions:</u>	N/A
<u>Frequency:</u>	Quarterly	<u>Field Length:</u>	9 <u>Type:</u> Alphanumeric
<u>Default Value:</u>	Blank	<u>Alternate Names:</u>	peo-ein
<u>Source:</u>	Provided by EDI for PEO units (record type 3 of the EDI format)		

Definition: A nine-position field from the EDI center that identifies that EIN of the client. This information may be used by the state to identify links between the PEO and the client account to ensure that duplicate or dropped reporting does not exist. This may be particularly useful if a client ceases to use a PEO and attempts are made to track who is reporting the data.

Note: See Appendix N – MWR File Layouts for the EDI format.

PEO Client Telephone Number

(Provided by EDI for PEO units)

<u>EQUI:</u>	Exclude	<u>Positions:</u>	N/A
<u>Frequency:</u>	Non-quarterly	<u>Field Length:</u>	10 <u>Type:</u> Numeric
<u>Default Value:</u>	blank	<u>Alternate Names:</u>	None
<u>Source:</u>	Provided by EDI for PEO units (record type 3 of the EDI format)		

Definition: A ten-position field for use from EDI to provide the client telephone number. The load program will move this field to the units telephone number field. This information would also be useful to contact the employer if the data are no longer reported by the PEO.

Note: See Appendix N – MWR File Layouts for the EDI format.

PEO Client Month and Year Became a Client

(Provided by EDI for PEO units)

<u>EQUI:</u>	Exclude	<u>Positions:</u>	N/A
--------------	---------	-------------------	-----

Frequency: Non-quarterly Field Length: 6 Type: Numeric
Default Value: blank Alternate Names: None
Source: Provided by EDI for PEO units (record type 3 of the EDI format)

Definition: A six-position field for use to identify when the unit started as a reporting unit of the PEO. This can be used as the initial liability date of the new reporter under the PEO's account. Note that the client account may still be operating if some of the employees continue to be reported directly by the client account. This information will be useful to determine if duplicate reporting is occurring for a particular time period and to explain why the client ceased to report the data under the client's account.

Note: See Appendix N – MWR File Layouts for the EDI format.

PEO Client Month and Year Ceased to be a Client

(Provided by EDI for PEO units)

EQUI: Exclude Positions: N/A
Frequency: Non-quarterly Field Length: 6 Type: Numeric
Default Value: blank Alternate Names: None
Source: Provided by EDI for PEO units (record type 3 of the EDI format)

Definition: A six-position field for use to identify when the unit ceased as a reporting unit of the particular PEO. This field would explain when the unit ceased to be reported by the PEO. This may be used to enter an end of liability date for the record. Note that this record should be researched to determine if the unit is out of business or being reported by the client or a different PEO.

Note: See Appendix N – MWR File Layouts for the EDI format.

PEO Client Worksite Economic Activity Description

(Provided by EDI for PEO units)

EQUI: Exclude Positions: N/A
Frequency: Non-quarterly Field Length: 33 Type: Numeric
Default Value: blank Alternate Names: None
Source: Provided by EDI for PEO units (record type 3 of the EDI format)

Definition: A short description from the respondent identifying what the economic activity is for the client record. This is useful to help identify NAICS codes.

Note: See Appendix N – MWR File Layouts for the EDI format.

Physical Location Address Block

(Required if available)

The Physical Location address consists of a block of six fields, which are described below. This address can be locked (as discussed for the Field Lock Position).

Note If the street address and room, apartment, or suite number does not fit on one line, the street should be put in Address Line 1, while the room, apartment or suite number is put in Address Line 2. At least one complete address (either Physical Location, UI Address, or Mailing/Other Address), including all appropriate address lines, city, state, and zip information must appear on each record. All physical location addresses should be geocodeable, at least to a zip-centroid latitude and longitude.

In some cases it is possible to identify that the UI address or the Mailing/Other address is actually the physical location address. The appropriate address type field should be marked and the address copied to the physical location address fields. At least one complete address (either Physical Location, UI Address, or Mailing/Other Address), including all appropriate address lines, city, state, and zip information must appear on each record. All large non-master records must have a physical location address.

Caution: Few states have an address field on the UI tax file or related supplemental files that include specific physical location addresses. Physical location address fields can be locked.

Physical Location Address Line 1

(Required if available)

<u>EQUI:</u>	Include	<u>Positions:</u>	244-278
<u>Frequency:</u>	Non-quarterly	<u>Field Length:</u>	35
<u>Default Value:</u>	Blank, if all other fields in the PL address block are blank	<u>Type:</u>	Alphanumeric
		<u>Alternate Names:</u>	PLA – Supplemental Location Information, Physical address 1, Physical location 1, PL address 1, PLA-line 1, PL-A1, phys_str

Format: Left justified

Source: Extracted from UI files; entered by state QCEW staff (from various sources); system copied (from Mailing/Other Address if MOA Address Type = 1); system copied (from UI Address if UI Address Type = 1); EDI Center (for worksites of centrally collected employers); CARS, MWR Web collection system

Definition: First line of the address where the unit is physically located.

System Action: If the Physical Location Address Line 1 is blank, but information is included on Physical Location Address Line 2, the state system moves it to Physical Location Address Line 1.

Note: Efforts should be made to ensure that the street address is geocodable and if the physical location address is the only address on the record, then it must also be mailable. At least one complete address (either Physical Location, UI Address, or Mailing/Other Address), including all appropriate address lines, city, state, and zip information must appear on each record. All large non-master records must have a physical location address that is geocodeable to at least the zip centroid latitude and longitude.

Physical Location Address Line 2

(Required if available)

<u>EQUI:</u>	Include	<u>Positions:</u>	279-313
<u>Frequency:</u>	Non-quarterly	<u>Field Length:</u>	35
<u>Default Value:</u>	Blank	<u>Type:</u>	Alphanumeric
		<u>Alternate Names:</u>	PLA – Street Address, Physical address 2, Physical location 2, PL address 2, PLA- line 2, PL-A2, phys_str2

Format: Left justified

Source: Copied by the system from the ARS refile (control) file; CARS; extracted from UI files; entered by state QCEW staff (from various sources); system copied (from Mailing/Other Address if MOA Address Type = 1); system copied (from UI Address if UI Address Type = 1)

Definition: Second line of the address where the unit is physically located.

System Actions: If the Physical Location Address Line 1 is blank, but information is included in Physical Location Address Line 2, the State system moves it to Physical Location Address Line 1.

Note: Efforts should be made to ensure that the street address is geocodable and if the physical location address is the only address on the record, then it must also be mailable. At least one complete address (either Physical Location, UI Address, or Mailing/Other Address), including all appropriate address lines, city, state, and zip information must appear on each record. All large non-master records must have a physical location address that is geocodeable to at least the zip centroid latitude and longitude.

Physical Location Address City

(Required if available)

<u>EQUI:</u>	Include	<u>Positions:</u>	314-343
<u>Frequency:</u>	Non-quarterly	<u>Field Length:</u>	30
<u>Default Value:</u>	Blank, if all other fields in the PL address block are blank.	<u>Type:</u>	Alphanumeric
		<u>Alternate Names:</u>	Physical city, PL city, PLA city, PL-C1, phys_cty

Format: Left justified

Source: Copied by the system from the ARS refile (control) file; CARS; extracted from UI files; entered by state QCEW staff (from various sources; system copied (from Mailing/Other Address if MOA Address Type = 1); system copied (from UI Address if UI Address Type = 1); EDI Center (for worksites of centrally collected employers); MWR Web collection

Definition: City or town where the unit is physically located.

Note: At least one complete address (either Physical Location, UI Address, or Mailing/Other Address), including all appropriate address lines, city, state, and zip information must appear on each record. All large non-master records must have a physical location address that is geocodeable to at least the zip centroid latitude and longitude.

Physical Location Address State

(Required if available)

EQUI: Include Positions: 344-345
Frequency: Non-quarterly Field Length: 2 Type: Alphabetic
Default Value: Blank, if all other fields in the PL address block are blank Alternate Names: Physical State, PL State, PLA-State, PL-ST, physst

Source: Copied by the system from the ARS refileing (control) file; CARS; extracted from UI files; entered by state QCEW staff (from various sources); system copied (from Mailing/Other Address if MOA Address Type = 1); system copied (from UI Address if UI Address Type = 1); EDI Center (for worksites of centrally collected employers) ; MWR Web collection

Definition: Post Office abbreviation of the state where the unit is physically located.

Valid Values: The standard Post Office abbreviations for states appear in Appendix C. Other valid values are as follows:

Destination	Abbreviation
American Samoa	AS
Guam	GU
Military Post Offices in Central and South America (APO Miami)	AA
Military Post Offices in Canada, Europe, Africa, and the Middle East (APO New York)	AE
Military Post Offices in Pacific and some areas of Alaska (APO San Francisco)	AP

Note: This abbreviation must match the state FIPS code for the state reporting the data, except in the rare circumstance where County code 996 (foreign locations) or 998 (out of state) is appropriate and is assigned. At least one complete address (either Physical Location, UI Address, or Mailing/Other Address), including all appropriate address lines, city, state, and zip information must appear on each record. All large non-master records must have a physical location address that is geocodeable to at least the zip centroid latitude and longitude.

Physical Location Address ZIP Code

(Required if available)

EQUI: Include Positions: 346-350
Frequency: Non-quarterly Field Length: 5 Type: Alphanumeric

Default Value: Blank, if all other fields in the PL address block are blank

Alternate Names: Physical ZIP, PL ZIP, PLA ZIP, PL-Z5, phys_zip

Source: Copied by the system from the ARS refileing (control) file; CARS; extracted from UI files; entered by state QCEW staff (from various sources); system copied (from Mailing/Other Address if MOA Address Type = 1); system copied (from UI Address if UI Address Type = 1); EDI Center (for worksites of centrally collected employers) ; MWR Web collection

Definition: ZIP Code of the address where the unit is physically located.

Note: At least one complete address (either Physical Location, UI Address, or Mailing/Other Address), including all appropriate address lines, city, state, and zip information must appear on each record. All large non-master records must have a physical location address that is geocodeable to at least the zip centroid latitude and longitude.

Physical Location Address ZIP Code Extension

(Required if available)

<u>EQUI:</u>	Include	<u>Positions:</u>	351-354
<u>Frequency:</u>	Non-quarterly	<u>Field Length:</u>	4
<u>Default Value:</u>	Blank	<u>Type:</u>	Alphanumeric
		<u>Alternate Names:</u>	Physical location - ZIP Ext., Physical ZIP expansion, PL ZIP Ext., PLA ZIPX, PL-Z4, phys_ext

Format: Left justified

Source: Copied by the system from the ARS refileing (control) file; CARS; extracted from UI files; entered by state QCEW staff (from various sources); system copied (from Mailing/Other Address if MOA Address Type = 1); system copied (from UI Address if UI Address Type = 1); EDI Center (for worksites of centrally collected employers) ; MWR Web collection

Definition: ZIP Code Extension of the address where the unit is physically located.

Note: At least one complete address (either Physical Location, UI Address, or Mailing/Other Address), including all appropriate address lines, city, state, and zip information must appear on each record. All large non-master records must have a physical location address that is geocodeable to at least the zip centroid latitude and longitude. However, ZIP Code Extension is not essential; if all other physical location address fields exist but ZIP extension is missing, the address still passes the edits.

Caution: Changes between zero-filled and blank ZIP code extensions are not considered changes to the physical location addresses.

Place (City) Code

(Required)

<u>EQUI:</u>	Include	<u>Positions:</u>	772-776
<u>Frequency:</u>	Quarterly	<u>Field Length:</u>	5
<u>Default Value:</u>	Blank	<u>Type:</u>	Numeric
<u>Source:</u>	BLS-supplied	<u>Alternate Names:</u>	City, Place, city-cd

Definition: Five-digit code assigned based on Census supplied boundary tables and latitude and longitude.

Note: Not all records that are assigned latitude and longitude values will also be assigned place codes. For more details on the place codes, refer to the following website:

<https://www.census.gov/geo/reference/codes/place.html>

PLA Type Code

(Required)

<u>EQUI:</u>	Include	<u>Position:</u>	661
<u>Frequency:</u>	Non-quarterly	<u>Field Length:</u>	1
<u>Default Value:</u>	Blank	<u>Type:</u>	Numeric
<u>Source:</u>	BLS-supplied	<u>Alternate Names:</u>	PLA Bypass

Definition: Unlike the Mailing/Other and UI Address Type code, the PLA type code does not compare the physical location address to any other address. The purpose of the PLA type code is to override or bypass specific data requirements, counts, geocoding, and editing criteria for a selected record when its physical location address is either incomplete or missing. Examples of where this may be appropriate are home health care worksites that are actual residences, domestics that are also operating in an actual residence, sales agents working out of their own homes, and some government facilities.

Valid Values:

C = PLA and county confirmed

P = PLA provided and not geocodable

R = PLA blank—worksite is a residence or private home

S = PLA blank—sales agents working out of their own home

G = government facility only providing city, state, and ZIP code but no street address

B = BLS-approved bypass for missing PLA

Blank = PLA is provided or missing but no bypass/override exists

Note: An edit will probably be built into the systems to identify when a bypass is being used that is not approved or unexpected.

Predecessor SESA ID

(Required if available)

The Predecessor SESA ID is a block of two fields that identifies or points to a predecessor record. It allows continuous establishments that change key fields (UI Account Number or RUN) to be linked. It consists of the Predecessor UI Account Number and Predecessor Reporting Unit Number. If either one of these data elements is present, both must be present.

Predecessor UI Account Number

(Required if available)

<u>EQUI:</u>	Include, P/S Record	<u>Positions:</u>	21-30
<u>Frequency:</u>	Transaction	<u>Field Length:</u>	10
<u>Default Value:</u>	Blank	<u>Alternate Names:</u>	Predecessor UI Account Number, Pred UI#

Format: Right justified, with unused positions zero-filled

Source: State UI system; QCEW staff (for federal reports and worksites); EDI

Definition: The UI Account Number under which the unit was previously reported if it has been reported under a different UI Account Number/Reporting Unit Number configuration. This is

explained in greater detail under Predecessor Reporting Unit Number and in Chapter 5. Two transaction records are created for each full or partial transaction, each showing one of the two directions of the transfer. For example, if a business (Joe's Manufacturing) buys three businesses (Jane Makes, Makes Them Right, and Tim's Technology), the following records would be created:

- Jane Makes is a predecessor of Joe's Manufacturing
- Joe's Manufacturing is a successor of Jane Makes
- Makes Them Right is a predecessor of Joe's Manufacturing
- Joe's Manufacturing is a successor of Makes Them Right
- Tim's Technology is a predecessor of Joe's Manufacturing
- Joe's Manufacturing is a successor of Tim's Technology
- Joe's Manufacturing had multiple predecessors

Predecessor Reporting Unit Number

(Required if available)

<u>EQUI:</u>	Include, P/S Record	<u>Positions:</u>	31-35
<u>Frequency:</u>	Non-quarterly	<u>Field Length:</u>	5
<u>Default Value:</u>	Blank if Predecessor UI is blank	<u>Alternate Names:</u>	Predecessor RUN, Pred RUN, Pred RU#
<u>Format:</u>	Right justified, with unused positions zero-filled		
<u>Source:</u>	QCEW staff; EDI		

Definition: The Reporting Unit Number under which the unit was previously reported if it has been changed to a different UI Account Number/Reporting Unit Number configuration. This is explained further below and in Section 5.1.

1. When there is more than one reporting unit to point to as the predecessor of this reporting unit, each specific Predecessor RUN should be assigned. (In these cases, BLS will generate a record with "99999" assigned as the Predecessor RUN to indicate that more than one reporting unit has been identified as a predecessor reporting unit. The "99999" record would be used by the LDB system.)
2. When there is more than one UI Account Number to point to as the predecessor of this reporting unit, each specific Predecessor UI Account Number should be assigned. (In these cases, BLS will generate a record with "9999999999" assigned to indicate that more than one UI Account has been identified as a predecessor UI account. The "9999999999" record would be used by the LDB system.)
3. The situations in 1 and 2 above can be fully identified in the LDB by reporting the Successor UI/Successor RUN in each of the multiple predecessor reporting units' (in one or more UI accounts) Successor UI Account Number and Successor RUN fields.

An establishment previously being reported under a different UI Account Number (or different RUN within the same UI account) that now begins reporting with a newly assigned UI Account Number (or newly assigned RUN within the same UI account) should identify its predecessor. Its Predecessor UI and Predecessor RUN fields should be assigned the UI Account Number and RUN under which the establishment was previously reported. If more than one predecessor existed, then each predecessor should be identified on the predecessor/successor transaction file. See Chapter 5 for more details.

The purpose of Predecessor and Successor UI/RUN assignment is to identify establishments as continuous, especially when they change ownership or UI number. This assignment is used whether or not the case satisfies the state UI definitions for legal predecessors and successors. For QCEW program purposes, a predecessor/successor relationship is one where the successor (the new owner of an establishment) performs similar operations to the predecessor (the previous owner of an establishment) using some or all of the predecessor's employees. These operations are frequently, but not necessarily, performed at the same location as the predecessor.

- (1) In the case of single accounts which are acquired by a new owner with a new (or different) UI Account Number, the previous UI Account Number and RUN (usually 00000) for the single account should be reported in the Predecessor UI and Predecessor RUN fields.
- (2) An individual establishment formerly reported via an MWR (containing several establishments) may be acquired by another multi-establishment reporter. In this case, the appropriate Predecessor UI and Predecessor RUN assigned to the newly acquired establishment would be the previous UI number and RUN of that establishment.
- (3) For cases involving the merger of several UI accounts either in whole or in part, it is usually possible to assign unique Predecessor UI/RUNS to each of the establishments being reported on the MWR of the re-formed multi establishment reporter.

Changes Within the Same UI Account: UI accounts that change reporting configuration (by breaking out or consolidating reporting units) should also be assigned a Predecessor UI/RUN. When data for a multi-unit employer are broken out for the first time, each newly disaggregated subunit should repeat the UI Account Number and RUN of the previously aggregated unit in the Predecessor UI Number and Predecessor RUN fields of the transaction records. When a multi-unit employer is collapsed (e.g., because the employer refuses to report on the MWR), the new combined record should include the UI Account Number of the previous multi-unit account in its Predecessor UI Number field. In this case, each individual worksite reporting unit number being collapsed would be written as separate transaction records in the transaction file.

In many cases it is not possible to accurately assign predecessor and successor UI/RUNs because of reporting discrepancies. In the textbook case where there is a change of ownership and all multi-establishment reporters are reporting their establishments on a MWR, it is possible to report predecessor and successor UI/RUNs accurately to the individual establishments. In these cases, it is important to report predecessor and successor UI/RUNs with the individual UI Account Number and/or RUN if individual UI Accounts/reporting units can be pointed to as the predecessor or successor.

This information may not be available in time to report it for the year and quarter when the change occurred. However, the Predecessor/Successor SESA ID fields should still be assigned as soon as the information becomes available.

Cautions:

- (1) The Predecessor UI Number should not be assigned unless the Predecessor RUN is also assigned. The Predecessor RUN should not be assigned unless the Predecessor UI Number is also assigned. If either field is present, both must be present.
- (2) Most state UI tax files do not include a reporting unit number field, as defined by BLS. In these cases, the Predecessor Reporting Unit Number should be zero filled when extracting Predecessor UI Account Numbers from the UI tax files. QCEW staff should then correct the Predecessor RUN as needed.

Predecessor/Successor Source Code

(Required)

<u>EQUI:</u>	Include, PS record	<u>Positions:</u>	36-37
<u>Frequency:</u>	Transaction	<u>Field Length:</u>	2
<u>Default Value:</u>	Blank	<u>Type:</u>	Alphanumeric
<u>Source:</u>	QCEW staff, UI extract, UI information, MWR Web, ARS, EDI, SUTA Dumping Detection Software, others		

Definition: The purpose of the predecessor/successor source code is to clearly identify if UI has made a legal determination of a predecessor/successor relationship or if the QCEW staff have obtained this information from other sources. It will also be useful when explaining why some information such as transfer dates may change from when QCEW staff believe it occurred to when UI actually makes the change to when QCEW staff actually reflect the change in their data.

Valid Values: This is a two digit field. An interim one digit version existed in the systems for a short period of time. Both sets of values are provided below.

<u>Source Code</u>	<u>Definition</u>	<u>Assignment</u>
EX	UI extract load	System-assigned
UI	UI, not loaded through the extract	User-assigned
ER	Information from the employer	User-assigned
SD	Wage record SUTA dumping detection system	System-assigned or may be user-assigned
ED	EDI data load	System-assigned or may be user-assigned
WR	Other wage record tool	System-assigned or may be user-assigned
RL	State record linkage/scoring	System-assigned or may be user-assigned
AR	ARS	User-assigned
MW	MWR	User-assigned
FS*	Other federal/state programs	User-assigned
BL	BLS weighted match system	User-assigned
MD	News Media	User-assigned
HS	Historical information – initialization of P/S table/files	System-assigned
OT	Other/Unidentified source	User-assigned
blank	Unknown	

*No longer used due to the Confidential Information Protection and Statistical Efficiency Act (CIPSEA).

Note: See Chapter 5 for more details.

Predecessor/Successor Posting Date

(Required)

<u>EQUI:</u>	Include, PS record	<u>Positions:</u>	46-53
<u>Frequency:</u>	Transaction	<u>Field Length:</u>	8 <u>Type:</u> Numeric
<u>Default Value:</u>	Blank	<u>Alternate Names:</u>	
<u>Source:</u>	System-assigned		

Definition: The date that the transaction was posted to the state QCEW database. This date helps track when the information was available to the state. It will also be used to determine if the record should be submitted on the EQUI file since the record does not include a reference year and quarter. In many states, the QCEW are notified of predecessor/successor transactions that are several quarters or years old. Without the date information, these data may conflict with the quarterly employment and wage information provided for the predecessor and successor records. Although the dates may not line up exactly, it is important that no reporting gaps or overlaps occur between the two (or more) records.

Predecessor/Successor Narrative Comment

(Required)

<u>EQUI:</u>	Include, PS record	<u>Positions:</u>	54-198
<u>Frequency:</u>	Transaction	<u>Field Length:</u>	145 <u>Type:</u> Alphanumeric
<u>Default Value:</u>	Blank	<u>Alternate Names:</u>	
<u>Source:</u>	QCEW staff assigned		

Definition: The Predecessor/Successor Narrative Comment is additional space to explain in more detail any relevant information about the predecessor/successor transaction that would not fit in other existing fields.

Predecessor/Successor Transfer Date

(Required if available)

<u>EQUI:</u>	Include, P/S Record	<u>Positions:</u>	38-45
<u>Frequency:</u>	Transaction	<u>Field Length:</u>	8 <u>Type:</u> Numeric
<u>Default Value:</u>	Blank	<u>Alternate Names:</u>	
<u>Format:</u>	YYYYMMDD		
<u>Source:</u>	UI, QCEW state staff		

Definition: The P/S Transfer Date is the actual date of the predecessor/successor transaction. If the transaction is a full transfer, then this date is typically the same as the end of liability date of the predecessor. If the transaction is a partial transfer to a new account, then the transfer date would be the same as the successor's initial liability date. Records with large employment (typically one hundred or greater) should have a transfer date.

Q

Quarter

(Required)

<u>EQUI:</u>	Include	<u>Position:</u>	8	<u>Type:</u>	Numeric
<u>Frequency:</u>	Quarterly	<u>Field Length:</u>	1	<u>Alternate Names:</u>	Reporting Quarter, Reference Quarter, qtr
<u>Default Value:</u>	None				

Source: Input micro transaction records, or system assigned

Definition: The calendar quarter for which the data are being reported.

Valid Values: 1 = January, February, March
2 = April, May, June
3 = July, August, September
4 = October, November, December

R

Reactivation Date

(Required if available)

<u>EQUI:</u>	Include	<u>Positions:</u>	536-543
<u>Frequency:</u>	Non-quarterly	<u>Field Length:</u>	8 <u>Type:</u> Numeric
<u>Default Value:</u>	Blank	<u>Alternate Names:</u>	react_dte, REACT
<u>Format:</u>	YYYYMMDD – four positions for year, two for month, and two for day (e.g., "20180401" for April 1, 2018)		

Source: State UI system; QCEW staff (for federal reports and worksites)

Definition: The date that an inactive unit or out-of-business unit (on the state UI system) is reactivated. If the reactivated unit is still present on the micro file, the Reactivation Date should be assigned while all other dates are maintained without change. If the reactivated unit is no longer in the QCEW system (having been inactive for more than six quarters) but is still on UI files, the record should be added to the micro file and should include appropriate dates extracted from the UI files: Input Date, Initial Date of Liability, and End of Liability. If the reactivated unit has not been submitted on the EQUI file (because it was inactivated on state system), the entire record should be submitted including the Input Date, Initial Date of Liability, and End of Liability Date. The End of Liability Date should not change when the reactivation date is assigned. If a reactivated unit again ceases operations and is assigned an End of Liability Date, the old End of Liability Date should be overwritten.

Once an establishment receives an “end of liability” date, meaning that the unit has ceased operations, it has no employees and pays no wages. In those cases where the state allows these businesses to begin operations again with the same UI Account Number, the inactive unit (in the QCEW system) should be assigned a reactivation date (while maintaining all other dates without change). The time period between the End of Liability Date and the Reactivation Date will indicate the period of time the unit was not operating as a business. This date will be used to track units on the LDB. This date may not exist or be available in all states. Some states may have a substantial number of these cases, including seasonal businesses.

Caution: Some states do not permit reactivations, while others do not track the reactivation date separately. If a previously inactivated unit is reactivated in the UI tax file by replacing the old liability date with a new date, the new date should be moved to the Reactivation Date. Some states refer to this as the reinstall date.

Reporting Unit Description

(Required if available for multi subunits (MEEI 3 and 5); optional for all other MEEI codes)

<u>EQUI:</u>	Include	<u>Positions:</u>	467-501
<u>Frequency:</u>	Non-quarterly	<u>Field Length:</u>	35 <u>Type:</u> Alphanumeric
<u>Default Value:</u>	Blank	<u>Alternate Names:</u>	RUD, Worksite Description, run_descr

Format: Left justifiedSource: QCEW staff; EDI Center (for worksites of centrally collected employers); MWR Web collection system

Definition: Unique description of the reporting unit, in terms meaningful to the reporter. When possible, use the employer's terminology. The vehicle for collection and verification of the

Reporting Unit Description (RUD) is the Multiple Worksite Report (MWR) and the availability of this data element is dependent on the reporter. (For MWR data collected by the EDI Center, the RUD is also provided by the employer.) The RUD should be consistent over time and across files. The RUD for each subunit should be provided back to the respondent on a quarterly basis via the MWR for verification and updating. Examples of the RUD include store numbers, plant numbers, and plant names, which apply to the subunit. If the reporter uses any system such as a store number or accounting code to identify the subunit, that information should be reported in the RUD field (for example, "STORE #2986" or "CODE #52"). If such a system is used by the reporter, wording (STORE, CODE) should be used along with the number to explain the meaning of the number. The RUD should be unique nationwide for users of the national office Longitudinal Data Base. BLS surveys will frequently send a data collection form to a corporate headquarters and refer to each worksite solely by the Reporting Unit Description (without reference to state).

Reporting Unit Descriptions should generally be provided for subunit records but may be omitted in certain situations. Specifically, RUDs are not required if all these conditions are met:

- (a) the employer has multiple establishments in only one state,
- (b) each establishment is uniquely identified by name and address,
- (c) the multi-establishment employer has relatively few subunits (five or less), and
- (d) the employer uses no other means to identify the establishment.

For a reporting unit which represents more than one establishment of a multi-establishment employer (e.g., MEEI = 4, 5, or 6), the RUD should describe the aggregation of establishments that the record represents. For example, if a record has an MEEI of 5, the RUD might contain "DALLAS PLANT AND FORT WORTH WAREHOUSE" as an adequate description.

- Cautions: (1) Industry descriptions or Short Titles should not be used in this field.
(2) This information is not usually available on UI tax files.

Reporting Unit Number

(Required)

<u>EQUI:</u>	Include, regular EQUI record and P/S record	<u>Positions:</u>	19-23
<u>Frequency:</u>	Non-quarterly	<u>Field Length:</u>	5
<u>Default Value:</u>	None	<u>Type:</u>	Numeric
<u>Format:</u>	Right justified, with unused positions zero-filled		
<u>Source:</u>	For new worksite units: state QCEW staff (or the EDI Center for centrally collected employers); MWR Web collection system For single and master records: system assigned zeros.		

Definition: A five-digit number used to uniquely distinguish worksites of a multi-unit account. This field should be consistent from quarter to quarter to allow identification of the same unit over time. The RUN is a five digit extension of the UI Account Number. Its purpose is to uniquely distinguish worksites of a multi-unit account. When more than one unit has the same state assigned UI Account Number, the RUN will distinguish each particular unit of a multi-establishment account from any other unit. Each subunit record within a UI account should be assigned a unique RUN. RUNs for subunits of the same UI Number should be assigned sequentially, and should not be re-used for a different reporting unit under the same UI Account Number. In the case of inactive reporting units, however, a reactivated unit may have the same RUN as before. When RUNs are assigned to newly broken out multi subunits, the first subunit must have a RUN of 00001, and the number for each additional subunit must increase by 1. For example, a UI account with three subunits will have RUNs numbered 00001, 00002, and 00003. Gaps in the numbering system may occur over time as a result of units going out of business or being sold. This systematic pattern will:

Make it easier for states to keep track of which RUNs have been used

Make apparent the next number available for use

Allow employers to keep state assigned RUNs in their payroll system – whether to provide data in a file or to generate a facsimile of the Multiple Worksite Report

Enable state staff, the EDI Collection Center, or employers to assign the proper RUN to a new unit when first setting it up

Valid Values: For single and master units, 00000. For subunits, values greater than 00000 and less than 99999. The Reporting Unit Number of each record should be consistent with the MEEI. Records with MEEI of 1 (single), 2 (master), 4, (multi reporting as single), or 6 (multi not solicited) should have a Reporting Unit Number = 00000. Records with MEEI of 3 (subunit) or 5 (combined subunit) should have a Reporting Unit Number greater than 00000.

Special Notes: (1) UI Account Number and Reporting Unit Number are the identifying fields (key fields) for records on the national office and state system databases.

(2) Reporting Unit Number 99999 should not be assigned since it is reserved at BLS for use in the Predecessor RUN and Successor RUN fields to indicate that the predecessor or successor is not unique. This information will be generated by EXPO and WIN systems and included on the transaction files when more than one predecessor or successor transaction record is created for the record between submittals to BLS. BLS will continue to use this information in the LDB system.

Caution: States that maintain worksite information on tax files are required to follow these guidelines on state and national office QCEW files. states that allow “orphans” or cases where a multi-establishment family terminates all units but one (leaving a single, surviving worksite) must convert its Reporting Unit Number to “00000” during the extract process and ensure the correct MEEI code is assigned. Most state UI tax files do not include a Reporting Unit Number field, as defined by BLS. In these cases, the Reporting Unit Number should be zero filled when extracting single and master accounts from UI tax files.

S

Setup Date

(Required if available)

<u>EQUI:</u>	Include	<u>Positions:</u>	512-519
<u>Frequency:</u>	Non-quarterly	<u>Field Length:</u>	8 <u>Type:</u> Numeric
<u>Default Value:</u>	Blank	<u>Alternate Names:</u>	Input Date, input_dte, SETUP
<u>Format:</u>	YYYYMMDD – four positions for year, two for month, and two for day (e.g., "20180501" for May 1, 2018)		
<u>Source:</u>	State UI system (for records with MEEI 1, 2, 4, or 6); system assigned (for new records with MEEI 3 or 5); QCEW staff (federal reports). For states unable to extract a Setup Date (MEEI 1, 2, 4, or 6), the system assigns the date that the record was first extracted from the tax file.		

Definition: This is the date that the information for the UI account is put into the state UI system. For a subunit (worksite) record, this is the date the record was assigned an active status code. Once assigned, this date would not change for a continuous UI account or for a continuous subunit. For an ownership change, the successor account would have a new setup date that would match the date the new record was input onto the state UI system. This date is necessary for determining when units were added to the state UI system. Potential uses are:

1. To distinguish between new units and units which were part of a previous sample frame used for selecting a sample at a specific point in time. (Sampling for births.) This date is important in simplifying the task of sampling for births.
2. For use in analyzing LDB data. Some businesses actually enter the state UI system some period of time after the business' initial date of liability (when the business actually pays wages to employees). Sometimes the first employment does not appear on QCEW files until the setup date even though the initial date of liability indicates that employees were present earlier.

Note: This date may not be accurate in some states for UI accounts that were already active before this became a required QCEW data element (before third quarter 1997).

Shared Secret/Temporary Password

(Used for security in the MWR Web systems)

<u>EQUI:</u>	Exclude	<u>Positions:</u>	N/A
<u>Frequency:</u>	Non-quarterly	<u>Field Length:</u>	8 <u>Type:</u> Alphanumeric
<u>Default Value:</u>	Blank	<u>Alternate Names:</u>	Shared Secret
<u>Format:</u>	Left justified if alphanumeric		
<u>Source:</u>	Provided by BLS for MWR Web solicitation		

Definition: Field provided by BLS to states for collection of information via the Web. This information would be printed on the MWR form and used by the employer for the respondent's initial registration and use of the MWR Web system. This information can be found on the MWR Web Solicitation Request File in Appendix N – MWR File Formats.

Note: the name that the respondent will see for this value is the "Password" or "Temporary Password".

SIC Code

(Required)

<u>EQUI:</u>	Include	<u>Positions:</u>	581-584
<u>Frequency:</u>	Quarterly	<u>Field Length:</u>	4 <u>Type:</u> Numeric
<u>Default Value:</u>	9999	<u>Alternate Names:</u>	Standard Industrial Classification code, SIC, sic- cd-chr

Source: System-transferred from ARS Control File in first quarter; QCEW staff (for worksites, economic changes); state UI files (new records); copied from previous quarter if unchanged on state system; EDI Center (for birth records of centrally collected employers)

Definition: Standard Industrial Classification code to identify the primary economic activity of the reporting unit. The primary activity is the primary product or group of products produced or distributed (or services rendered) by the establishment (reporting unit). The primary activity of the enterprise is the primary activity of the establishments within a state.

Caution: This code was replaced with the NAICS code as the primary industry code of record. SICs are no longer coded or maintained.

Valid Values: valid four-digit codes as shown in the 1987 SIC Manual, plus 0740, 0780, and 5810.

Solicitation ID/Temporary ID

(Provided by BLS to states from the Respondent for MWR Web collection)

<u>EQUI:</u>	Exclude	<u>Positions:</u>	N/A
<u>Frequency:</u>	Non-quarterly	<u>Field Length:</u>	12 <u>Type:</u> Alphanumeric
<u>Default Value:</u>	Blank	<u>Alternate Names:</u>	

Format:

Source: BLS MWR Web system

Definition: SolicitationID is a unique identifier respondents use when they register to the MWR Web system. Note that this is the 12-character version of the SolicitationID, where the first three characters specify the IDCF survey. This information can be found on the MWR Web Solicitation Request File in Appendix N – MWR File Formats.

The name that the respondent will see for this value is the “ID” or “Temporary Account Number”.

Special Indicator

(Required if available)

<u>EQUI:</u>	Include	<u>Position:</u>	576
<u>Frequency:</u>	Non-quarterly	<u>Field Length:</u>	1 <u>Type:</u> Alphanumeric
<u>Default Value:</u>	Blank	<u>Alternate Names:</u>	SPCL, spec_ind

Source: QCEW staff

Definition: Code used to identify records that may require special handling or provide special information.

Valid Values:

T = Indian Tribal Council

P = PEO Employer (used in Standardized UI QUEST extract but converted to “L” in EXPO and WIN)

L = Staff in establishment leased to a PEO
blank (default value) = All other records

Note: Other codes may be developed later.

Special Criteria: Professional employer (staff leasing) firm (master) would be coded with P; subunit with leased employment would be coded with L.

State Code

(Optional in state systems; required on the EQUI and the national office micro file)

EQUI: Include, regular EQUI Positions: 2-3
record and P/S record

Frequency: Non-quarterly Field Length: 2 Type: Numeric
Default Value: None Alternate Names: State FIPS code
Source: System

Definition: The two-digit numeric FIPS designator for the state that handles the UI Account, inclusive of the District of Columbia, Puerto Rico and the Virgin Islands.

Valid Values: The valid values for each state appear in Appendix C. Invalid codes include 00, 03, 07, 14, 43, 52, 57-71, 73-77, and numbers greater than 78.

Caution: This field will be system-assigned by EXPO and WIN.

State Use Field

(Optional; not reported on the EQUI)

EQUI: Positions: N/A
Frequency: Non-quarterly Field Length: 35 Type: Alphanumeric
Default Value: Blank Alternate Names: State_use, STUSE
Format: Left justified
Source: QCEW staff

Definition: A field available for use by the state for their own purposes.

Caution: This is for internal use only. Some states, however, with converted UI Account Numbers, retain the old UI numbers in the non-quarterly state use field in their state system. These are transmitted to BLS in positions 1130-1165 of the EQUI file.

Status Code

(Required)

<u>EQUI:</u>	Include	<u>Position:</u>	544
<u>Frequency:</u>	Quarterly	<u>Field Length:</u>	1 <u>Type:</u> Numeric
<u>Default Value:</u>	None	<u>Alternate Names:</u>	Status; Status Code, SC, STA, status_cd

Source: Derived from UI tax file status codes, QCEW staff, or system assigned. May be system assigned based on Initial Liability Date, End of Liability Date, and/or Reactivation Date. May be provided for new multi-establishment units sent through EDI or the Web collection. Also assigned when a record is “deleted” from the file

Definition: A code showing whether or not the record is active for QCEW purposes. This does not refer to the UI status of the record. If a record is active for any part of the quarter, it is active for the entire quarter. Most status codes are system-assigned based on the combination of Initial Liability Date, End of Liability Date, and Reactivation Date.

Valid Values: 1 = active (also includes reactivated units, active for a portion of the time, and active for the entire quarter)
 2 = inactive (also includes terminated, closed, sold, etc.)
 3 = inactive; filler for non-submitted quarters of a record (in the national office system only)
 9 = pending (e.g., a new unit is set up as pending for a multi-establishment in a quarter to begin the breakout reporting as active in a later quarter)

Note: For records that have been imputed for one or two quarters and have been delinquent for an additional five quarters, a 2 (inactive) will be assigned unless there is reason to believe the unit is still active. The standard QCEW systems include a systems option to inactivate these records.

Caution: Several state tax systems distinguish between inactive and terminated accounts. Other systems include information on delinquent accounts, seasonal accounts, and other special characteristics. States need to match specialty codes in their UI tax systems to the QCEW standardized codes of 1, 2, and 9 to ensure that all records that should be included are extracted.

Successor SESA ID

(Required if available)

The Successor SESA ID is a block of two fields that identifies or points to a successor record. It allows continuous establishments that change key fields (UI Account Number or RUN) to be linked. It consists of the Successor UI Account Number and Successor Reporting Unit Number. If either one of these data elements is present, both must be present.

Successor UI Account Number

(Required if available)

<u>EQUI:</u>	Include, P/S Record	<u>Positions:</u>	21-30
<u>Frequency:</u>	Transaction	<u>Field Length:</u>	10
<u>Default Value:</u>	Blank	<u>Alternate Names:</u>	Successor UI Account Number, Successor UI#

Format: Right justified, with unused positions zero-filled.Source: State UI system; QCEW staff (for federal reports and worksites)

Definition: The UI Account Number under which the unit will be reported, (or is now reporting) if its UI Account Number/Reporting Unit Number configuration will change (or has already changed.) This is explained in greater detail under Successor Reporting Unit Number and in Chapter 5. Two transaction records are created for each full or partial transaction, each showing one of the two directions of the transfer. For example, if a business (Joe's Manufacturing) buys three businesses (Jane Makes, Makes Them Right, and Tim's Technology), the following records would be created:

- Jane Makes is a predecessor of Joe's Manufacturing
- Joe's Manufacturing is a successor of Jane Makes
- Makes Them Right is a predecessor of Joe's Manufacturing
- Joe's Manufacturing is a successor of Makes Them Right
- Tim's Technology is a predecessor of Joe's Manufacturing
- Joe's Manufacturing is a successor of Tim's Technology
- Joe's Manufacturing had multiple predecessors

Successor Reporting Unit Number

(Required if available)

<u>EQUI:</u>	Include, P/S Record	<u>Positions:</u>	31-35
<u>Frequency:</u>	Transaction	<u>Field Length:</u>	5
<u>Default Value:</u>	Blank if Successor UI Number is blank	<u>Alternate Names:</u>	Successor RUN, Succ RUN, Succ RU#

Format: Right justified, with unused positions zero-filledSource: QCEW staff

Definition: The Reporting Unit Number under which the unit will be reported (or is now reporting), if its UI Account Number/Reporting Unit Number configuration will change (or has already changed). This is explained further below, and in Section 5.1.

1. When there is more than one reporting unit to point to as the successor of a predecessor unit, each specific Successor RUN should be assigned. (In these cases, BLS will generate a record with "99999" as the Successor RUN to indicate that more than one reporting unit has been identified as a successor reporting unit. The "99999" record would be used by the LDB system.)

2. When there is more than one UI Account Number to point to as the successor of a predecessor unit, each specific Successor UI Account Number should be assigned. (In these cases, BLS will generate a record with “9999999999” as the Successor UI Account Number to indicate that more than one UI Account has been identified as a successor UI Account. The “9999999999” record would be used by the LDB system.)
3. The situations in 1 and 2 above can be fully identified in the LDB by reporting the Predecessor UI/Predecessor RUN in each of the multiple successor reporting units’ (in one or more UI accounts) Predecessor's UI Account Number and Predecessor's Reporting Unit Number fields.

An establishment that ceases reporting under one UI Account Number/Reporting Unit Number and begins reporting with a newly assigned UI/RUN should have a Successor UI Number and Successor RUN identified for the record that will no longer be reported. The Successor UI Number and Successor RUN should reflect the newly assigned and currently reporting UI number/Reporting Unit Number.

The purpose of Predecessor and Successor UI/RUN assignment is to identify establishments as continuous, especially when they change ownership or UI number. This assignment should be used whether or not the case satisfies the state UI definitions for legal predecessors and successors. For QCEW program purposes, a predecessor/successor relationship is one where the successor (the new owner of an establishment) performs similar operations to the predecessor (the previous owner of an establishment) using some or all of the predecessor’s employees. These operations are frequently, but not necessarily, performed at the same location as the predecessor.

This information may not be available in time to report it for the year and quarter when the change occurred. However, the Predecessor/Successor SESA ID fields should still be assigned as soon as the information becomes available.

Cautions:

(1) The Successor UI Number should not be assigned unless the Successor RUN is also assigned. The Successor RUN should not be assigned unless the Successor UI Number is also assigned. If either field is present, both must be present.

(2) Most state UI tax files do not include a reporting unit number field, as defined by BLS. In these cases, the Successor Reporting Unit Number should be zero filled when extracting Successor UI Numbers from the UI tax files. QCEW staff should then correct the Successor RUN as needed.

T

Tax Rate

(Required; not reported on the EQUI)

<u>EQUI:</u>	Exclude	<u>Positions:</u>	N/A
<u>Frequency:</u>	Quarterly	<u>Field Length:</u>	5 <u>Type:</u> Numeric
<u>Default Value:</u>	None for contributory employers. Zero for reimbursable, non-UI-covered or UCFE covered	<u>Alternate Names:</u>	Rate, Employer Tax Rate, tax_rate, TAXRT
<u>Format:</u>	Right justified with leading zeros; a decimal place is implied after the first position from the left. For example, the value of 00325 is a tax rate of 0.0325, or 3.25% (i.e. divide by 100 to obtain the tax rate percentage).		
<u>Source:</u>	State UI system		

Definition: Tax rate used during the reference quarter to tax contributory employer's taxable wages to meet the employer's obligation to the UI fund. Tax rates should be assigned, typically by the UI tax unit, to all active, tax-rated or experience-rated accounts.

Rounding Criteria: To the nearest thousandths place.

Note: Tax rates for master records are copied to all the subunits of the UI account.

Special Criteria: System must associate the appropriate tax rate with any given micro data record. System must be able to maintain this association on exported files.

Taxable Wages

(Required)

<u>EQUI:</u>	Include	<u>Positions:</u>	639-649
<u>Frequency:</u>	Quarterly	<u>Field Length:</u>	11 <u>Type:</u> Numeric
<u>Default Value:</u>	None	<u>Alternate Names:</u>	Tax Wages, TAXW, tax_wg
<u>Format:</u>	Right justified with leading zeros		
<u>Source:</u>	1) State UI system (masters and singles) 2) System assigned (imputed for worksites).		

Definition: Wages of the employer (reported) that are UI taxed. Contributory accounts only. Even if an employer has a zero tax rate, taxable wages should be reported for subject wages up to the state wage limit.

Note: "Subject wages" is not the same as "taxable wages". "Subject wages" are wages that meet the criteria for being taxed irrespective of minimum or maximum per-employee cutoffs. Thus, if the state limited its UI Tax collections to X percent of each employee's subject wages less than \$25,001 in a calendar year, employees earning \$80,000 per year would have "subject wages" of \$80,000, providing their wages were otherwise subject to UI Tax, irrespective of the maximum per-employee taxable limit. In this example, each employee's wages up to \$25,000 in the year would be "taxable wages", and each employee's wages above \$25,000 in the year would not be "taxable wages".

Rounding Criteria: All wage fields are rounded to the nearest whole dollar amounts. For example, if taxable wages are \$122,465.49, then 00000122465, and not 00012246549, should

appear in this field. If taxable wages are \$122,465.50, then the data should be rounded up so that 00000122466 appears in this field.

Taxable Wages Indicator Flag

(Required)

<u>EQUI:</u>	Exclude	<u>Position:</u>	N/A
<u>Frequency:</u>	Quarterly	<u>Field Length:</u>	1 <u>Type:</u> Alphanumeric
<u>Default Value:</u>	M	<u>Alternate Names:</u>	Taxable Wages Indicator; TaxW-Ind., tax_wg_ind,

Source:

- 1) System generated for all data entered via extract or batch.
- 2) Assigned when data imputed or prorated.
- 3) QCEW staff (manual override).

Definition: Indicator showing the source of the taxable wages.

Valid Values: Blank or R = reported data

B = BLS-initialized quarter. The national office system assigns this taxable wage indicator when no EQUI record was received from the state for this quarter

C = changed (re-reported)

E = imputed single unit taxable wages or imputed worksite taxable wages prorated from imputed master taxable wages

H = hand-imputed (not system generated)

K = special system-generated imputation to reflect data impacted by a catastrophe

L = late reported (overrides prior imputation)

M = missing data

N = zero-filled pending resolution of long-term delinquent reporter

P = prorated from reported master to worksites

X = non-numeric taxable wages zero-filled pending further action

Caution: Imputed data on the UI tax file should not be copied or extracted.

Telephone Number

(Required if available)

<u>EQUI:</u>	Include	<u>Positions:</u>	502-511
<u>Frequency:</u>	Non-quarterly	<u>Field Length:</u>	10 <u>Type:</u> Alphanumeric
<u>Default Value:</u>	Blank	<u>Alternate Names:</u>	Phone, PH-AR, PHN7, area_cd,

Format: Ten digits comprised of 3-digit area code, 3-digit prefix, and 4-digit suffix

Source: State UI system; QCEW staff (entered from MWR or ARS forms or from staff research), EDI, MWR Web, CARS.

Definition: The telephone number for the employer. Preferably this is the number of the actual employer (not an agent), and it corresponds to the physical location of the establishment. The master record phone number should not be copied to subunits. Do not enter a 3-digit area code only, without the corresponding 7-digit number. Do not enter directory assistance number, (xxx) 555-1212. If the physical location telephone number is not available, a telephone number for another location or section of that employer would be preferable, e.g. the number of the corporate headquarters or central office, as opposed to the number for an outside payroll preparer or accounting firm.

Note: Some states do retain the phone number of payroll providers to ask the preparer questions, however; this is not the preferred telephone number if an employer number is available.

Telephone Extension

(Required if available)

<u>EQUI:</u>	Include	<u>Positions:</u>	845-849
<u>Frequency:</u>	Non-quarterly	<u>Field Length:</u>	5
<u>Default Value:</u>	Blank	<u>Type:</u>	Numeric
<u>Format:</u>	Right justified with leading zeros	<u>Alternate Names:</u>	Phone Extension
<u>Source:</u>	State UI system (if available), QCEW staff, MWR Web, and EDI		

Definition: This field includes any telephone extension number that would be used to point to a specific contact within the respondent organization.

Note: ARS Web does not collect nor export to states the respondents' telephone extensions.

Total Wages

(Required)

<u>EQUI:</u>	Include	<u>Positions:</u>	627-637
<u>Frequency:</u>	Quarterly	<u>Field Length:</u>	11
<u>Default Value:</u>	None	<u>Type:</u>	Numeric
<u>Format:</u>	Right justified with leading zeros	<u>Alternate Names:</u>	Total Quarterly Wages, Gross Wages, Wages, TOTW, TW, tot_wg
<u>Source:</u>	<ol style="list-style-type: none"> 1) State UI system 2) System generated (imputed data) 3) EDI Center (for worksites of centrally collected employers) 4) QCEW staff (other) 5) MWR Web collection 		

Definition: Total amount of UI-subject wages paid quarterly to covered workers on all the payrolls during the entire reference quarter. Includes taxable and nontaxable (excess) wages, and bonuses. Total Wages may include the cash value of meals, lodging, bonuses, stock options, tips and other gratuities depending on state laws and if these items are furnished with the job.

Rounding Criteria: All wage fields are rounded to the nearest whole dollar amounts. For example, if total wages are \$122,465.49, then 00000122465, and not 00012246549, should appear in this field. If total wages are \$122,465.50, then the data should be rounded up so that 00000122466 appears in this field.

Total Wages Indicator Flag

(Required)

<u>EQUI:</u>	Include	<u>Position:</u>	638
<u>Frequency:</u>	Quarterly	<u>Field Length:</u>	1
<u>Default Value:</u>	M	<u>Alternate Names:</u>	Wage Flag, Quarterly Wage Imputation Flag, TOTWI, tot_wg_ind, TW-ind

Source: 1) System generated (blank, K, M, N, P, R, E, X, and S) for all data entered via extract or batch or from an imputation routine.
2) QCEW staff (manual override).

Definition: Indicator showing the source of the wage data.

Valid Values: Blank or "R" = reported data

C = changed (re-reported)

E = imputed single unit or prorated worksite wages from an imputed master record

H = hand-imputed (not system generated)

K = special system-generated imputation to reflect data impacted by a catastrophe

L = late reported (overrides prior imputation)

M = missing data

N = zero-filled pending resolution of long-term delinquent reporter

P = prorated from master to worksite

S = aggregated master from reported MWR or EDI data

W = imputed from wage record wages

X = non-numeric wages zero-filled pending further action

Note: State should resolve all "X" records before submission on the EQUI.

Special: State System assigns R for all blanks when generating the EQUI file.

Caution: Imputed data on the UI tax file should not be copied or extracted.

Township Code

(Required for New England states and New Jersey, optional for all other states)

<u>EQUI:</u>	Include	<u>Positions:</u>	602-604
<u>Frequency:</u>	Quarterly	<u>Field Length:</u>	3
<u>Default Value:</u>	999 for New England states and New Jersey, zero-filled for all other states	<u>Alternate Names:</u>	TWN, Town, res_cd, residence code

Source: State UI system; copied from previous quarter if unchanged on state system; QCEW staff (staff research); ARS Control File (system transferred); CARS; EDI Center (for birth records of centrally collected employers); MWR; MWR Web

Definition: Three-digit numeric code required for New England states and New Jersey, used to identify the township of the location or place of business. FIPS codes are not required for the township code. New England states as well as New Jersey must notify national office through their regional office of any changes to their township code list before submitting the affected deliverable EQUI file. The notification should include all affected combinations of county and township codes and include a narrative description that identifies the county/township name of each combination. Use of 900 on master records is optional and is not required.

Valid Values: Valid township codes for the state plus the following township equivalent codes: (For a full description of the township equivalent codes, see Section 2.1.3.)

- 900 = Master record
- 995 = Statewide with no primary township
- 996 = Foreign locations
- 998 = Out-of-state locations
- 999 = Unknown locations

Note: Township equivalent codes other than 999 first became valid with third quarter 1997 data.

Township Extension

(Optional; for state use only.)

EQUI:	Exclude	Position:	N/A
Frequency:	Quarterly	Field Length:	1
Default Value:	None	Type:	Alphanumeric
		Alternate Names:	None

Definition: A one-position field for filler. For states other than New Jersey and the New England states, this may be used as an optional extension to township code, creating a four-position zone field. Typically this information is collected and maintained at a more detailed level than county level.

Example: "Traffic zone" information for the Highway department.

Caution: New England states and New Jersey are required to collect, maintain, and submit three-digit township information.

Trade Name

(Required if available)

EQUI:	Include	Positions:	98-132
Frequency:	Non-quarterly	Field Length:	35
Default Value:	Blank	Type:	Alphanumeric
Format:	Left justified	Alternate Names:	DBA Name, TRDNM, dba
Source:	State UI system; QCEW staff (for worksites); EDI Center (for worksites of centrally collected employers); ARS Web collected-data files; MWR Web collected-data files		

Definition: Name of the reporting unit as it is known to the public.

Special Criteria: Either the Legal Name or Trade Name **must** be present for each record. If both are available, both must be present. (See the examples for Legal Name.)

Transaction Code

(Required)

EQUI:	Include, regular EQUI record and P/S record	Position:	1
--------------	---	------------------	---

Frequency: State and BLS generated
Field Length: 1
Type: Alphanumeric
Default Value: Blank
Alternate Names: INA
Source: State system

Definition: Identifies if the record submitted on the EQUI is a

T = Trailer record

H = Header record

D = Delete record

F = Full record

P = Predecessor/Successor record

U = a selected number of records are submitted by BLS staff to resolve significant problems that must be corrected quickly for critical BLS users.

Blank = used for limited update directly by BLS

Type of Coverage

(Required)

EQUI: Include
Position: 659
Frequency: Quarterly
Field Length: 1
Type: Numeric
Default Value: None
Alternate Names: Coverage code, COV, Reimbursable code, REIM code, REM code, typcov_cd, TOC

Source: State UI system; QCEW staff for federal, UCFE-covered accounts

Definition: Each employer covered under the state's Unemployment Insurance or Unemployment Compensation for Federal Employees (UCFE) is assigned a type of coverage using a state-specific coding scheme. These codes identify whether the employer is determined to be experience rated, covered under a standard contributions rate, or is an employer who is not required to pay contributions but must reimburse when a claim is filed against the account. Three states have a provision for the possible use of employee contributions. Several states also collect data from non-UI/UCFE covered employers.

Valid Values: 0 = Experience rated (contributory) (employer funded). Accounts coded as "0" should be experience-rated, assigned a standard contributions rate, or similar or special tax rate as specified in the state UI laws. Employees in these accounts do not contribute to the UI trust fund.

1 = Reimbursable. Certain nonprofit organizations, state or local government entities, and political subdivisions which elect or are required to reimburse state UI trust fund when a claim is filed against the employer in lieu of contributions as provided in the state UI laws.

2 = Taxable (employer and employee funded). Employers deduct employee contributions from the employees' pay and include them with the required employer contributions.

3 = Reimbursable (employer reimburses upon demand but the employee contributes on a periodic basis).

8 = Non-subject accounts. (These will not be submitted on the EQUI.) These are accounts that do not meet the UI or UCFE coverage requirements but provide data to the state for other purposes (e.g., statistical research).

9 = Federal accounts covered under UCFE.

Known Valid Code Combinations within a state: 0, 1, 8, 9

0, 1, 9

1, 2, 9

2, 3, 9

1, 2, 8, 9

Example: Valid codes for a state with employee contributions would be 2, 3, and 9.

System Action: When this code is assigned to a master record in a multi-unit account, the state system copies the code from the master record to the subunit records in the same UI account.

Caution: State-specific codes must be properly mapped to the six valid codes allowed in the QCEW standardized state systems.

U

UI Account Number

(Required)

EQUI: Include, regular EQUI record and P/S record Positions: 9-18

Frequency: Non-quarterly Field Length: 10 Type: Numeric

Default Value: None Alternate Names: UI Tax Number, UI#, unum, ACCT

Format: Right justified, with unused positions zero-filledSource: State UI system; QCEW staff (for federal reports)

Definition: The identification number assigned by the state UI unit to identify employers covered by the state UI laws, or the identification number assigned by the state UI unit or the QCEW unit to identify Federal government installations covered by UCFE provisions, or the identification number assigned by the QCEW unit to identify non-UI and non-UCFE covered employers maintained in the QCEW files. This field should be consistent from quarter to quarter to allow identification of the same unit over time. Any suffix or prefix that is used to identify individual units of a multi-unit employer should be reported in the Reporting Unit Number field and not as part of the UI Account Number.

Valid Values: Cannot be all zeros or all nines. Must be numeric in all positions.

Special Notes: (1) UI Account Number 9999999999 should not be assigned since it is reserved for use in the Predecessor UI Number and Successor UI Number fields for the BLS LDB system to indicate that the predecessor or successor is not unique.

(2) UI Account Number and Reporting Unit Number are the identifying fields (key fields) for records on the national office and state system databases.

(3) If the state plans to change the structure of the UI Account Number, the state must coordinate implementing these changes with the regional Office and national office before submitting the EQUI file. Notification is necessary since any change to the structure would affect the processing of the file. In addition, the changes should be described in the Remarks section of the QCEW Program Data Transmittal Form.

UI Address Block

The UI address consists of a block of six fields, which are described below. The UI address should be extracted from UI tax files, but should not be updated. If it needs correction and the record does not have a usable Mailing/Other address, copy the UI address to the Mailing/Other address block and make corrections there. Unlike the Mailing/Other address and the Physical Location address, the UI address cannot be locked.

Caution: Some states will use the Mailing/Other address fields to correct UI addresses.

Mailing/Other address fields can be locked.

Note: At least one complete address (either Physical Location, UI Address, or Mailing/Other Address), including all appropriate address lines, city, state, and zip information must appear on each record.

Note: The UI Address Block does not include either
UI Address Foreign Country Code or
UI Address Foreign Postal Code.

UI Address Line 1

(Required if available)

<u>EQUI:</u>	Include	<u>Positions:</u>	133-167
<u>Frequency:</u>	Non-quarterly	<u>Field Length:</u>	35
<u>Default Value:</u>	Blank	<u>Type:</u>	Alphanumeric
		<u>Alternate Names:</u>	UI Address – Secondary Address Line, UI-A1, tax_str

Format: Left justified

Source: State UI system

Definition: First line of the street address on the UI Tax file.

System Action: If the UI Address Line 1 is blank, but information is included on UI Address Line 2, the state system moves it to UI Address Line 1. If the UI address for a subunit (worksite) is blank, and if the worksite has no other address, then the state system copies the master UI address to the worksite.

UI Address Line 2

(Required if available)

<u>EQUI:</u>	Include	<u>Positions:</u>	168-202
<u>Frequency:</u>	Non-quarterly	<u>Field Length:</u>	35
<u>Default Value:</u>	Blank	<u>Type:</u>	Alphanumeric
		<u>Alternate Names:</u>	UI Address – Delivery Address Line, UI-A2, tax_str2

Format: Left justified

Source: State UI system

Definition: Second line of the street address on the UI Tax file.

System Action: If the UI Address Line 1 is blank, but information is included on UI Address Line 2, the state system moves it to UI Address Line 1. If the UI address for a subunit (worksite) is blank, and if the worksite has no other address, then the state system copies the master UI address to the worksite.

UI Address City

(Required if available)

<u>EQUI:</u>	Include	<u>Positions:</u>	203-232
<u>Frequency:</u>	Non-quarterly	<u>Field Length:</u>	30
<u>Default Value:</u>	Blank, if all other fields in the UI address block are blank	<u>Type:</u>	Alphanumeric
		<u>Alternate Names:</u>	UI-C1, tax_cty

Format: Left justified

Source: State UI system

Definition: City or town of the address on the UI Tax file. For foreign addresses, the city, province or state and country should preferably be included in this field. The list of Canadian provinces are listed below.

Default Value: Blank, if all other fields in the UI address block are blank

Alternate Names: UI-Z5, tax_zip

Source: State UI system

Definition: ZIP Code of the address on the UI Tax file. (For foreign addresses, the foreign country's postal code should be left justified in the ZIP code field, with any trailing unused portions being left blank. For example, the first five positions of a six position Canadian ZIP code should be placed in this field).

System Action: If the UI address for a subunit (worksite) is blank, and if the worksite has no other address, then the state system copies the master UI address to the worksite.

UI Address ZIP Code Extension

(Required if available)

EQUI: Include

Positions: 240-243

Frequency: Non-quarterly

Field Length: 4 Type: Alphanumeric

Default Value: Blank

Alternate Names: UI-Z4, tax-ext

Format: Left justified. Place position 6 of a Canadian ZIP Code in the first position of this field, followed by three blanks.

Source: state UI system

Definition: ZIP Code Extension of the address on the UI Tax file.

System Action: If the UI address for a subunit (worksite) is blank, and if the worksite has no other address, then the state system copies the master UI address to the worksite.

UI Address Foreign Country Code (This is a new data element.)

EQUI: Exclude

Positions:

Frequency: Non-quarterly

Field Length: 3 Type: Alphanumeric

Default Value: Blank (USA should not be the default.)

Alternate Names:

Format:

Source: State UI system

Definition: 3-character ISO country code of the UI address.

Valid Values: Valid values are available in Appendix B (Country Codes) of the "QCEW System Developers Guide for Standardized UI QUEST Extract", which can be found on Stateweb

Note: EXPO, WIN-202, and the BLS processing system do not include this as a separate data element but append it to the end of the UI city field. This data element is included in the Standardized UI QUEST extract. This data element is not part of the UI Address Block. This data element is to be left blank for addresses in Puerto Rico or the U.S. Virgin Islands.

UI Address Foreign Postal Code (This is a new data element.)

EQUI: Exclude

Positions:

Frequency: Non-quarterly

Field Length: 7 Type: Alphanumeric

Default Value: Blank

Alternate Names:

Format:

Source: State UI system

Definition: The postal code associated with the data in the UI Address if the "UI Address Foreign Country Code" field is available and out of country.

Note: EXPO, WIN-202, and the BLS processing system do not include this data element. This data element is included in the Standardized UI QUEST extract. This data element is not part of the UI Address Block. Canadian Postal Codes are included in the UI Address Zip Code and the first position of the UI Address Zip Extension. This data element is to be left blank for addresses in Puerto Rico or the U.S. Virgin Islands.

UI Address Type Code

(Optional use in states)

<u>EQUI:</u>	Include	<u>Position:</u>	729
<u>Frequency:</u>	Non-quarterly	<u>Field Length:</u>	1
<u>Default Value:</u>	Blank	<u>Type:</u>	Alphanumeric
<u>Source:</u>	State UI system (if available)	<u>Alternate Names:</u>	UI Type, ui_addr_ind, UI-AT

Definition: Identifies when the UI address is also the PLA.

Valid Values: 1 = Physical address (physical and UI address are the same)
 2 = Address (where the mail goes directly to the unit and may include the P.O. Box or RFD addresses)
 3 = Corporate central office mail address
 9 = UI Address or unknown

V

Version Fields

Version fields are two fields maintained on the national Office micro database (Administrative Version and Quarterly Version) that indicate the submittal version of a state's files to BLS. These fields indicate when data items were submitted to BLS. These version fields will allow processes and analysis to better focus on records updated during the quarter. Updates to these fields will occur each time a specific record's data are submitted for the processing quarter.

Administrative Version

(Provided on national Office micro files only)

<u>EQUI:</u>	N/A	<u>Positions:</u>	N/A
<u>Frequency:</u>	Non-quarterly	<u>Field Length:</u>	3 <u>Type:</u> Numeric
<u>Default Value:</u>	Blank	<u>Alternate Names:</u>	Aver
<u>Format:</u>	Right justified		
<u>Source:</u>	System generated by BLS		

Definition: Contains a value for each quarter that indicates when that quarter's data were updated. This includes both the latest change to a quarterly field or a change to administrative data. Each of these fields contains three positions. The first position represents the ones place of the submittal year. The second position represents the submittal quarter. The third position represents the version of the quarterly submittal (e.g., "1" indicates the first EQUI file submitted; "2" indicates the next submittal, whether it's an Update EQUI or a set of BLS Corrections or a Subset EQUI; "3" indicates the third submittal of the quarterly data, whether it's an Update EQUI or a set of BLS Corrections or a Subset EQUI; and so forth).

Note: If the record was not submitted for the current processing quarter, the Aver value will be all zeroes.

Example: When the 2017/3 initial EQUI files are processed, all submitted records will be given an Aver value of "731." If this same record is supplied on the 2017/3 update file, the Aver value will be "732." If this record is submitted on the 2017/4 initial EQUI file, the Aver value will be "671."

Note: As long as a processed file includes a record with a given UI-RUN, the AVER for that UI-RUN will be updated to the corresponding AVER (as described above) regardless of whether or not the UI-RUN is updated by the processed file.

Quarterly Version

(Provided on national Office micro files only)

<u>EQUI:</u>	N/A	<u>Positions:</u>	N/A
<u>Frequency:</u>	Non-quarterly	<u>Field Length:</u>	3 <u>Type:</u> Numeric
<u>Default Value:</u>	Blank	<u>Alternate Names:</u>	Qver
<u>Format:</u>	Right justified		
<u>Source:</u>	System generated by BLS		

Definition: Contains a value for each quarter that indicates when the record was last submitted in terms of the processing quarter. Each of these fields contains three positions. The first position represents the ones place of the submittal year. The second position represents the submittal quarter. The third position represents the version of the quarterly submittal (e.g., "1"

indicates the first EQUI file submitted; "2" indicates the next submittal, whether it's an Update EQUI or a set of BLS Corrections or a Subset EQUI; "3" indicates the third submittal of the quarterly data, whether it's an Update EQUI or a set of BLS Corrections or a Subset EQUI; and so forth).

Example: When the 2017/3 initial EQUI files are processed and the first and second quarter updates are provided along with current quarter data for a particular record, the Qver values for each of these three quarters will be set to "731." If this same record is supplied on the update file with only a third quarter record, the 2017/3 Qver value will be "732." The 2017/2 and 2017/1 Qver values will both still be "731." If this record is submitted on the 2017/4 initial EQUI file with no back quarter records, the 2017/4 Qver value will be "741." The 2017/3 Qver value will remain "732." The 2017/2 and 2017/1 Qver values will both still be "731."

Note: As long as a processed file includes a record with a given UI-RUN-YEAR-QTR, the QVER for that UI-RUN-YEAR-QTR will be updated to the corresponding QVER (as described above) regardless of whether or not the UI-RUN-YEAR-QTR is updated by the processed file.

W

Wage Record Count of Unique Social Security Numbers (SSNs)

(Required if available on MEEI records coded 1, 2, 4, or 6; Optional on MEEI records coded 3 or 5)

<u>EQUI:</u>	Include	<u>Positions:</u>	828-833
<u>Frequency:</u>	Quarterly	<u>Field Length:</u>	6 <u>Type:</u> Numeric
<u>Default Value:</u>	Blank	<u>Alternate Names:</u>	WRC
<u>Format:</u>	Right justified with leading zeros if numeric		
<u>Source:</u>	State UI system (if available)		

Definition: This is the count of unique social security numbers reported to the UI, of the employees that received pay at any time during the reference quarter, on the wage record report for the account

Caution: Leave blank if not available.

Derivation: For each UI account, tally the number of social security numbers appearing on the current quarter wage record report, counting each unique social security number only once.

Example: If a wage record report has 20 separate “lines of information for a social security record” but 3 social security numbers are repeated, each receiving possibly regular wages for one record and the other record for each possibly for bonus checks. The wage record count for this field would be 17.

Wage Record Count Migrating to Largest Wage Record Recipient (Possible or Actual Successor)

(Required if available on MEEI records coded 1, 2, 4, or 6; Optional on MEEI records coded 3 or 5)

<u>EQUI:</u>	Include	<u>Positions:</u>	1061-1066
<u>Frequency:</u>	Quarterly	<u>Field Length:</u>	6 <u>Type:</u> Numeric
<u>Default Value:</u>	Blank	<u>Alternate Names:</u>	LWRR
<u>Format:</u>	Right justified with leading zeros if numeric		
<u>Source:</u>	State UI system (if available)		

Definition: This is the count of the largest number of unique social security numbers reported on wage records that went from the prior UI account to a different, current UI account number. For instance, a UI account reported 500 wage records in the prior quarter and 300 of these are now reported under other UI accounts. Using wage record information, if 50 are reported by one UI account and 250 by another UI account, then 250 would be reported in this count.

Caution: Leave blank if not available.

Derivation: Compare the wage records for the account for the current quarter and the prior quarter. For those wage records reported to the account in the prior quarter that are now reported to different accounts and not reported to this account, tally the unique social security number wage records for each of the receiving accounts. Report the highest tally in this field.

Example: Account 1234567890 had 300 people reported on wage records in the prior quarter; 200 of these social security numbers are not reported on account 1234567890's current quarter wage record report. In the current quarter, account 2345678901 has 150 of these social security numbers and account 3456789012 has 50 of them on their wage record reports. 150 would be reported in this field.

Wage Record – Largest Wage Record Recipient – Possible or Actual Successor

(Required if available on MEEI records coded 1, 2, 4, or 6; Optional on MEEI records coded 3 or 5)

<u>EQUI</u> :	Include	<u>Positions</u> :	1051-1060
<u>Frequency</u> :	Quarterly	<u>Field Length</u> :	10 <u>Type</u> : Numeric
<u>Default Value</u> :	Blank	<u>Alternate Names</u> :	<u>LWRR UI</u>
<u>Format</u> :	Right justified with leading zeros if numeric		
<u>Source</u> :	State UI system (if available)		

Definition: This is the account number of the business that received the wage records reported in the Wage Record Count Migrating to the Largest or Dominant Wage Record Recipient.

Caution: Leave blank if not available.

Derivation: Compare the wage records for the account for the current quarter and the prior quarter. For those wage records reported to the account in the prior quarter that are now reported to different accounts and not reported to this account, tally the unique social security number wage records for each of the receiving accounts. There are three possible types of situations occurring: 1) the wage record movement described above occurred and the recipient of the wage records is known to be a successor (possibly because UI had already made the determination or from some other source), 2) the wage record movement described above occurred and the recipient is known NOT to be a successor (the state QCEW analyst should have some ability to make this determination and mark it in the EXPO and WIN systems), and 3) the wage record movement described above occurred and it is unknown if the recipient is a successor or not. Report the UI account number with the highest tally in this field where the relationship is unknown (exclude known successors and accounts known not to be linked) .

Note: Exclude the reference account as its own possible predecessor or successor.

Example: Account 1234567890 had 300 people reported on wage records in the prior quarter; 200 of these social security numbers are not reported on account 1234567890's current quarter wage record report. In the current quarter, account 2345678901 has 150 of these social security numbers and account 3456789012 has 50 of them on their wage record reports. The state did not yet make a determination of the possible relationship between accounts 12345675690 and 2345678901. Account number 2345678901 would be reported in this field.

Wage Record Count from Largest Wage Record Contributor (Possible or Actual Predecessor)

(Required if available on MEEI records coded 1, 2, 4, or 6; Optional on MEEI records coded 3 or 5)

<u>EQUI:</u>	Include	<u>Positions:</u>	1077-1082
<u>Frequency:</u>	Quarterly	<u>Field Length:</u>	6 <u>Type:</u> Numeric
<u>Default Value:</u>	Blank	<u>Alternate Names:</u>	LWRC
<u>Format:</u>	Right justified with leading zeros if numeric		
<u>Source:</u>	State UI system (if available)		

Definition: This is the count of the largest number of unique social security numbers reported on wage records that came to this account from a different UI account number. For instance, a UI account reported 100 wage records in the prior quarter and 300 additional wage records in the current quarter, for a total of 400 wage records. Using wage record information, if 50 of those new wage records were reported in one UI account in the prior quarter and 250 of those new wage records were reported by another UI account in the prior quarter, the 250 would be reported in this count.

Caution: Leave blank if not available.

Derivation: Compare the wage records for the account for the current quarter and the prior quarter. For those wage records reported to the account in the current quarter that were reported to different accounts and not reported to this account, tally the unique social security number wage records for each of these contributing accounts. Report the highest tally in this field.

Example: Account 4567890123 had 600 people reported on wage records in the current quarter; 400 of these social security numbers were not reported on account 4567890123's prior quarter wage record report. In the prior quarter, account 5678901234 had 300 of these social security numbers and account 6789012345 had 100 of them on their wage record reports. 300 would be reported in this field for account 4567890123.

Wage Record – Largest Wage Record Contributor – Possible or Actual Predecessor

(Required if available on MEEI records coded 1, 2, 4, or 6; Optional on MEEI records coded 3 or 5)

<u>EQUI:</u>	Include	<u>Positions:</u>	1067-1077
<u>Frequency:</u>	Quarterly	<u>Field Length:</u>	10 <u>Type:</u> Numeric
<u>Default Value:</u>	Blank	<u>Alternate Names:</u>	<u>LWRC UI</u>
<u>Format:</u>	Right justified with leading zeros if numeric		
<u>Source:</u>	State UI system (if available)		

Definition: This is the account number of the business that previously reported the wage records counted in the Wage Record Count from the Largest or Dominant Wage Record Contributor.

Caution: Leave blank if not available.

Derivation: Compare the wage records for the account for the current quarter and the prior quarter. For those wage records reported to the account in the current quarter that were reported to different accounts and not reported to this account, tally the unique social security number wage records for each of these contributing accounts. Report the UI account number with the highest tally in this field.

Note: Exclude the reference account as its own possible predecessor or successor.

Example: Account 4567890123 had 600 people reported on wage records in the current quarter; 400 of these social security numbers were not reported on account 4567890123's prior quarter wage record report. In the prior quarter, account 5678901234 had 300 of these social security numbers and account 6789012345 had 100 of them on their wage record reports. Account number 5678901234 would be reported in this field for account 4567890123.

Wage Record Count of Covered Workforce "New Entrants"

(Required if available on MEEI records coded 1, 2, 4, or 6; Optional on MEEI records coded 3 or 5)

<u>EQUI</u> :	Include	<u>Positions</u> :	1095-1100		
<u>Frequency</u> :	Quarterly	<u>Field Length</u> :	6	<u>Type</u> :	Numeric
<u>Default Value</u> :	Blank	<u>Alternate Names</u> :	<u>WREN</u>		
<u>Format</u> :	Right justified with leading zeros if numeric				
<u>Source</u> :	State UI system (if available)				

Definition: This is the count of wage records included in the current quarter for the employer that were not reported to any one reporting wage records in the prior quarter. These records appear for the first time on the wage records for the two consecutive quarters.

Note: This count may be effected by missing wage records, delinquent or sporadic reporters, as well as those employers not required to submit wage records, such as federal government. This is a count of "New Entrants to the State's Workforce", and may be one source of an employer's new hires or rehires.

Caution: Leave blank if not available.

Derivation: Compare the wage records for the account for the current quarter and the prior quarter. For those wage records reported to the account in the current quarter that were not reported to this account or any other account in the prior quarter, tally the unique social security number wage records. Report this tally in this field.

Example: Account 7890123456 had 200 people reported on wage records in the current quarter; 50 unique social security numbers were not reported on account 7890123456's prior quarter wage record report nor were they reported under any other UI account in the prior quarter. 50 would be reported in this field for account 7890123456.

Wage Record Count of Covered Workforce – Hires

(Required if available on MEEI records coded 1, 2, 4, or 6; Optional on MEEI records coded 3 or 5)

<u>EQUI</u> :	Include	<u>Positions</u> :	1083-1088		
<u>Frequency</u> :	Quarterly	<u>Field Length</u> :	6	<u>Type</u> :	Numeric
<u>Default Value</u> :	Blank	<u>Alternate Names</u> :	<u>N/A</u>		
<u>Format</u> :	Right justified with leading zeros if numeric				
<u>Source</u> :	State UI system (if available)				

Definition: This is the count of wage records included in the current quarter for the employer that were not reported to the employer on the account's reporting wage records in the prior quarter. The count is always of unique social security numbers, not a count of lines on the report or checks.

Note: This count may be effected by missing wage records, and delinquent or sporadic reporters. This is different from the count of "New Entrants to the State's Workforce". The hires count will include the count of employees reporting to a different employer in the prior quarter and

now reporting this employer as well as employees who are still reporting to the other employer as well as now to this employer.

Caution: Leave blank if not available. If the employer did not provide any wage records last quarter even though it was active and had positive employment but does report wage records this quarter, do not count the difference as hires.

Wage Record Count of Covered Workforce “Exits”

(Required if available on MEEI records coded 1, 2, 4, or 6; Optional on MEEI records coded 3 or 5)

<u>EQUI:</u>	Include	<u>Positions:</u>	1101-1106		
<u>Frequency:</u>	Quarterly	<u>Field Length:</u>	6	<u>Type:</u>	Numeric
<u>Default Value:</u>	Blank	<u>Alternate Names:</u>	<u>WREX</u>		
<u>Format:</u>	Right justified with leading zeros if numeric				
<u>Source:</u>	State UI system (if available)				

Definition: This is the count of wage records reported in the prior quarter for an employer that are not reported by any employer in the current quarter. These records appeared for the last time on the wage records the last quarter of the two consecutive quarters.

Note: This count may be effected by missing wage records, delinquent or sporadic reporters, as well as those employers not required to submit wage records, such as federal government, and those on extended leave, e.g., maternity or paternity leave. This is a count of “Left the State’s Workforce, and may be one source of an employer’s separations.

Caution: Leave blank if not available.

Derivation: Compare the wage records for the account for the current quarter and the prior quarter. For those wage records reported to the account in the prior quarter that are not reported to this account or any other account in the current quarter, tally the unique social security number wage records. Report this tally in this field.

Example: Account 8901234567 had 250 people reported on wage records in the prior quarter; 70 unique social security numbers found on the prior quarter report are not reported on account 8901234567’s current quarter wage record report nor are they reported under any other UI account in the current quarter. 70 would be reported in this field for account 8901234567.

Wage Record Count of Covered Workforce – Separations

(Required if available on MEEI records coded 1, 2, 4, or 6; Optional on MEEI records coded 3 or 5)

<u>EQUI:</u>	Include	<u>Positions:</u>	1089-1094		
<u>Frequency:</u>	Quarterly	<u>Field Length:</u>	6	<u>Type:</u>	Numeric
<u>Default Value:</u>	Blank	<u>Alternate Names:</u>	<u>N/A</u>		
<u>Format:</u>	Right justified with leading zeros if numeric				
<u>Source:</u>	State UI system (if available)				

Definition: This is the count of wage records reported in the prior quarter for an employer that are not reported to the employer on the account's reporting wage records in the current quarter. These records appeared for the last time on the wage records the last quarter of the two consecutive quarters for a specific account. This count is different from the count of exits since it includes those wage records that are still found on the state UI wage record system reporting to other employers. The count is always of unique social security numbers, not a count of lines on the report or checks.

Note: This count may be effected by missing wage records, and delinquent or sporadic reporters. It will also include those still on the employers payroll but on extended leave, e.g., maternity or paternity leave.

Caution: Leave blank if not available. If the employer did not provide any wage records this quarter even though it was active and had positive employment but did report wage records last quarter, do not count the difference as separations.

Wage Record Count of "Continuous Records"

(Required if available on MEEI records coded 1, 2, 4, or 6; Optional on MEEI records coded 3 or 5)

EQUI:	Include	Positions:	1107-1112
Frequency:	Quarterly	Field Length:	6 Type: Numeric
Default Value:	Blank	Alternate Names:	WRCR
Format:	Right justified with leading zeros if numeric		
Source:	State UI system (if available)		

Definition: This is the count of wage records included in both the current and prior quarters wage records for the employer. The individuals represented in this count may also be reported by other employers when the individual is a multiple job holder.

Caution: Leave blank if not available.

Derivation: Compare the wage records for the account for the current quarter and the prior quarter. For those wage records reported to the account in both the current and prior quarter, tally the unique social security number wage records. Report this tally in this field.

Example: Account 9012345678 had 40 people reported on wage records in both the current and prior quarter. 40 would be reported in this field.

Wage Record Matched Number of Occurrences

(Required if available on MEEI records coded 1, 2, 4, or 6; Optional on MEEI records coded 3 or 5)

EQUI:	Exclude	Positions:	N/A
Frequency:	Quarterly	Field Length:	6 Type: Numeric
Default Value:	Blank	Alternate Names:	Number of Occurrences, matched SSN's, MSHSSN, shared wage records
Format:	Right justified with leading zeros if numeric		
Source:	State UI system (if available)		

Definition: This is the number of wage records that were previously reported under one account and later report to a specific different account. These wage record tallies identify the number of employees potentially involved in a predecessor/successor transfer.

Caution: Leave blank if not available or not applicable.

Derivation: When comparing wage records by Social Security Number, identify all the unique SSNs that were reported to one specific account in the prior reference period and are now reported to one specific different account.

Example: Account 2233445566 had 600 people reported on wage records in the prior quarter; 400 of these social security numbers were not reported on account 2233445566's current quarter wage record report. In the current quarter, account 7788990011 had 300 of these social security numbers and account 9988776655 had 100 of them on their wage record reports. The wage record matched number of occurrences between 2233445566 and 7788990011 was 300 and the wage record matched number of occurrences between 2233445566 and 9988776655 was 100.

Wage Record Wages

(Required if available on MEEI records coded 1, 2, 4, or 6; Optional on MEEI records coded 3 or 5)

EQUI:	Include	Positions:	834-844	
Frequency:	Quarterly	Field Length:	11	Type: Numeric
Default Value:	Blank	Alternate Names:	WRW	
Format:	Right justified with leading zeros if numeric			
Source:	State UI system (if available)			

Definition: This is the total amount of wages reported on the wage record report for wages paid during any time in the quarter.

Caution: Leave blank if not available.

Derivation: Total all wage records reported on the wage records regardless of the number of times that a given social security number may be reported separately.

Example: 15 wage records are reported to account 1122334455 in the current quarter, there are a total of \$7,456,635.68 in wages reported. Round to a whole dollar amount and report 7456636 in this field.

Website Address

(Required if available)

EQUI:	Include	Positions:	990-1049	
Frequency:	Non-quarterly	Field Length:	60	Type: Alphanumeric
Default Value:	Blank	Alternate Names:	web	
Format:	left justified if alphanumeric			
Source:	Web collection systems, QCEW state staff			

Definition: This is the Uniform Resource Locator (URL), or website, of the business for which the respondent is reporting employment and wage data.

X

No Current Entries.

Y

Year

(Required)

<u>EQUI:</u>	Include	<u>Positions:</u>	4-7		
<u>Frequency:</u>	Quarterly	<u>Field Length:</u>	4	<u>Type:</u>	Numeric
<u>Default Value:</u>	None	<u>Alternate Names:</u>		Reporting Year, Reference Year, Yr	

Format: YYYY (four-digit year, e.g., "2018")

Source: Input micro transaction records, or system assigned

Definition: Four-digit reporting or reference year of the data.

Caution: The year should be within the time period maintained on the file. For example, if the quarters available on the state systems are

- future quarter: 2018/2
- current quarter: 2018/1
- prior quarter: 2017/4
- 2nd historical quarter: 2017/3
- 3rd historical quarter: 2017/2
- 4th historical quarter: 2017/1
- 5th historical quarter: 2016/4

The Year would be 2016, 2017, or 2018.

Year and Quarter of New Latitude and Longitude

(Required)

<u>EQUI:</u>	Include	<u>Positions:</u>	767-771		
<u>Frequency:</u>	Twice (old and new)	<u>Field Length:</u>	5	<u>Type:</u>	Numeric
<u>Default Value:</u>	Blank	<u>Alternate Names:</u>		Lat/Long Date, GYRQ, ll-chg-qtr, ll-chg-yr	

Format: YYYYQ

Source: State System Assigned

Definition: Year Quarter that new geocode information would be available for publication, etc. Used to keep the latitude and longitude in sync with quarter area codes such as county, town, city, etc.

Z

No Current Entries.

Appendix C – State Codes

The table below lists state FIPS Codes and standard state abbreviations, and identifies the BLS regional office that serves each state. A second table at the end identifies valid abbreviations that may be used for non-state destinations.

FIPS Code	State	State Abbreviation	Region
01	Alabama	AL	Atlanta
02	Alaska	AK	San Francisco
04	Arizona	AZ	San Francisco
05	Arkansas	AR	Dallas/Kansas City
06	California	CA	San Francisco
08	Colorado	CO	Dallas/Kansas City
09	Connecticut	CT	Boston/New York
10	Delaware	DE	Philadelphia
11	District of Columbia	DC	Philadelphia
12	Florida	FL	Atlanta
13	Georgia	GA	Atlanta
15	Hawaii	HI	San Francisco
16	Idaho	ID	San Francisco
17	Illinois	IL	Chicago
18	Indiana	IN	Chicago
19	Iowa	IA	Chicago
20	Kansas	KS	Dallas/Kansas City
21	Kentucky	KY	Atlanta
22	Louisiana	LA	Dallas/Kansas City
23	Maine	ME	Boston/New York
24	Maryland	MD	Philadelphia
25	Massachusetts	MA	Boston/New York
26	Michigan	MI	Chicago
27	Minnesota	MN	Chicago
28	Mississippi	MS	Atlanta
29	Missouri	MO	Dallas/Kansas City
30	Montana	MT	Dallas/Kansas City
31	Nebraska	NE	Chicago
32	Nevada	NV	San Francisco
33	New Hampshire	NH	Boston/New York
34	New Jersey	NJ	Philadelphia
35	New Mexico	NM	Dallas/Kansas City
36	New York	NY	Boston/New York
37	North Carolina	NC	Atlanta
38	North Dakota	ND	Chicago

FIPS Code	State	State Abbreviation	Region
39	Ohio	OH	Chicago
40	Oklahoma	OK	Dallas/Kansas City
41	Oregon	OR	San Francisco
42	Pennsylvania	PA	Philadelphia
44	Rhode Island	RI	Boston/New York
45	South Carolina	SC	Atlanta
46	South Dakota	SD	Chicago
47	Tennessee	TN	Atlanta
48	Texas	TX	Dallas/Kansas City
49	Utah	UT	Dallas/Kansas City
50	Vermont	VT	Boston/New York
51	Virginia	VA	Philadelphia
53	Washington	WA	San Francisco
54	West Virginia	WV	Philadelphia
55	Wisconsin	WI	Chicago
56	Wyoming	WY	Dallas/Kansas City
72	Puerto Rico	PR	Boston/New York
78	Virgin Islands	VI	Boston/New York

Destination	Abbreviation
American Samoa	AS
Guam	GU
Military Post Offices in Central and South America (APO Miami)	AA
Military Post Offices in Canada, Europe, Africa, and the Middle East (APO New York)	AE
Military Post Offices in Pacific and some areas of Alaska (APO San Francisco)	AP
Canada	CN
All other foreign countries	ZZ

Appendix D – Due Dates

The submittal schedule for the Enhanced Quarterly Unemployment Insurance (EQUI) deliverable is viewable in the Fed/State Deliverables Calendar which is available for download on the main StateWeb page. In addition, the deliverable dates are listed in the Cooperative Agreement and the first page of the QCEW Valid Values spreadsheet, commonly known as the Cheat Sheet, which is located on the “QCEW Quick Links” menu under the QCEW section on StateWeb. Subset due dates are found in the same places.

At the start of each quarter, states and regional offices should review the quarterly EQUI file processing email distributed by the national office that lists major processing changes for the current quarter. In addition, this email provides a calendar of due dates for important milestones for current quarter processing. States should add these due dates to their calendar or processing schedule.

The state may meet the EQUI deliverable requirements in one of the following ways:

1. Create the EQUI deliverable through the service center
2. Transmit the EQUI deliverable via file transfer protocol (FTP) **no later than** the due date
3. Transmit the EQUI deliverable via EUSWeb **no later than** the due date

Section 12.3 covers the technical aspects of each transmittal option

In addition to generating the EQUI file and making it available to the national office for processing no later than the due date, states must ensure all fields of the QCEW Program Data Transmittal Form are properly populated.

If the state cannot submit the EQUI deliverable by the due date or if there are any data quality problems that will significantly affect the accuracy of the EQUI deliverable, then the state must notify the regional office as soon as possible so appropriate action can be taken.

States should work closely with their regional office to develop the most efficient processing schedule to produce the highest quality data on the EQUI deliverable. Examples of state processing schedules can be found on StateWeb.

If a state provides a subset to BLS, it must be made available for BLS processing **no later than** the due date.

Appendix E – State Processing Schedule

The two tables below outline the suggested schedule for State processing, although actual schedules may vary in each State due to State-specific circumstances.

The first table gives a view of the quarterly processing cycle, detailing a suggested weekly schedule for generating each quarter's Enhanced Quarterly Unemployment Insurance (EQUI) deliverable. Note that due dates and deadlines are subject to change. While deadlines must be met, the steps needed to reach those deadlines do not have hard and fast deadlines. The schedule listed below should be treated as a guideline, rather than a firm schedule States are required to follow.

The second table gives a view of the annual processing cycle, showing the major steps for conducting the Annual Refiling Survey (ARS) and for generating quarterly EQUI files throughout the year.

Quarterly Processing Cycle

The following table is a proposed weekly activity schedule for processing State data in a single quarter. Sample time frames are given for each activity, based on particular quarterly processing cycles. Where available, EXPO Jobs and WIN Routines that correspond with the proposed activities are included. States are encouraged to work with their regional office to develop a processing schedule that best fits their data environment.

STATE PROCESSING ACTIVITIES
<p>Prior to and Including Week 1 <i>Week 1 is the week following the end of each calendar quarter or reference period. For 1Q processing, Week 1 is the first week of April. For 2Q, this is the first week of July, etc.</i></p>
<p>UI sends Quarterly Contribution Reports (QCRs), QCEW sends Multiple Worksite Reports (MWRs), and Reports of Federal Employment and Wages (RFEWs) to employers. Electronic reporting reminders are sent, including MWR Web emails. Review and update State edit parameters.</p>
<p>Prior to the start of the first quarter (ONLY!!): EXPO-QCEW States only- Load non-economic code changes and other information to State system from the refiling system.</p>
<p>Weeks 2-5</p> <p>Receive completed QCRs, MWRs, and RFEWs. Enter data from QCRs to UI tax file, screen reports, and generate missing data notices (which may be done by UI or QCEW, depending on the State). Process MWRs and RFEWs, and enter data to State system. Load Contractor collected MWR data Load MWR BLS Web Confirmed Register File Load BLS MWR Collected Data file and Confirmed Registry Updates</p>
<p>Week 6 or 7</p> <p>After the Initial submittal, roll the quarter which archives the oldest data and moves the next quarter to file, and loads the initial UI extract.</p>

STATE PROCESSING ACTIVITIES
Impute missing data for all incomplete QCRs on hand. States may wait until after the second UI extract to do this. Send notices for delinquent QCRs. Follow-ups for missing MWRs and RFEWs. Begin contacting delinquent reporters. Create 2 nd mailing print file for MWR Print Contract - current collection quarter
Weeks 6-9
Contact delinquent reporters not submitting MWRs or RFEWs with significant employment. Enter missing data (provided by employers in response to missing data notices) to State system. Refer wage corrections to UI tax section (done in some States but not all). Run edits and review edit listings. Possible future quarter Editing on reference quarter while finishing up previous quarter. Perform focused editing (FESTER) of micro data. Do multi-balance edit for current and previous quarters. Perform predecessor/successor edit. Document unusual fluctuations in the data, and assign micro level comment codes as needed. Enter corrections and comments from edit review to State system. Load Contractor collected MWR Data Week 9: Create list of MWR Actives
Week 9 or 10
Perform second UI extract with edit and estimation for accounts with missing data. Prorate accounts with missing subunit data. Create State Historical File Create initial mailing print file for MWR print contract- next quarter collection
Weeks 10-12
Contact large imputed employers. Run edits and review edit listings. Document unusual fluctuations in the data, and assign micro level comment codes as needed. Enter corrections and comments from edit review to State system.
Week 13
Multi-balance edit for the current and previous quarters Predecessor/successor edit (if needed) Streamlined focused edit Produce gross error listing Generate 46f data and send to regional office for review
Week 14
Multi-balance edit for the current and previous quarters Focused editing EQUI-Based Scoring edit, just prior to submittal
Thursday: EQUI File due (Note: Tuesday due date for 3Q)
Weeks 14-17
BLS edits EQUI data. BLS questions/listings forwarded to States for additional corrections or comments.

STATE PROCESSING ACTIVITIES
States update State system with corrections and comments based on their own review, BLS review, or other sources.
Week 18
Tuesday: Subset file due (optional for most States)
BLS edits Subset data. BLS questions/listings forwarded to States for additional corrections or comments. States update State system with corrections and comments based on their own review, BLS review, or other sources.
Thursday: Clean certifications due

Annual Processing Cycle

The following table is a recommended schedule for the major processing activities, including both the ARS (Annual Refiling Survey) and the quarterly EQUI deliverables. As shown on this schedule, at most times during the year the State is working with two quarters of data as well as the ARS.

This table begins in July, since this is when the ARS processing cycle begins. The national office disseminates a checklist of directions at the start of each ARS cycle as an aid to States.

Early- July For the end of the current refiling year	
BLS Activities	State Activities
	Cut off the updating of refiling responses and other code changes to the ARS control file
	For EXPO States- apply refiling information to the State system
	Run final Summary Management Report
	Refile is submitted with the first quarter EQUI
July	
BLS initializes ARS Web and tests the system	States submit updates to contact information sheet (ongoing)
BLS creates control and print files	States load control file to State system. States may generate first summary management report of the new cycle
BLS sends NCA 1 print spreadsheets to States	States provide YES or No responses for NCA1

NVS proofs posted for 24-hour review	States review NVS proofs and provide feedback
First ARS email blast is sent	
August	
NVS1a/NCA1 mailing complete	States send <i>remove</i> list prior to 2 nd email blast
NVM Web closes for 2Q collection	
Second ARS email blast sent	
September	
BLS uploads ARS transmittals 1 and 2. Transmittal 2 includes NVM data	States process ARS transmittals 1 and 2.
NVM Web opens for 3Q collection	
BLS send NVS1b, NVM1 print files and State contact information spreadsheet to the contractor	
NVS1b mailing complete	
October	
BLS uploads ARS transmittals 3 and 4	States process ARS data from transmittals 3 and 4, and send the SMR by the 25 th
Contractor completes the first NVM mailing	
Third ARS email blast is sent	
November	
BLS uploads ARS transmittal 5	States process ARS data from transmittal 5 and sends the SMR by the 25 th
NVM Web closes for 3Q collection	
December	
	States send remove lists prior to 4 th email blast
BLS uploads ARS transmittal 6, including NVM responses	States process ARS data from transmittal 6 and sends the SMR by the 25 th
BLS sends NVM2 print files to contractor	
Late-December, NVM Web opens for 4Q collection	
January	
BLS sends NCA2 print spreadsheet to States	State review NCA2 print spreadsheet, provide a yes or no for mailing
BLS sends NVS2, NCA2, and State contact information spreadsheet to print contractor	

BLS uploads ARS transmittal 7	States process ARS data from transmittal 7, and send the SMR by the 25 th
NVM2, NVS2, and NCA2 mailing complete	
February	
BLS uploads ARS transmittal 8 and 9	States process ARS data from transmittal 8 and 9, and send the SMR by the 25 th
NVM Web closes for 4Q collection	
March	
BLS uploads ARS transmittal 10, including NVM responses	States process ARS data from transmittal 6 and sends the SMR by the 25 th
NVM Web opens for 1Q collection	
Fourth ARS email blast (if needed)	
April	
BLS uploads ARS transmittal 11	States process ARS data from transmittal 11, and send the SMR by the 25 th
BLS sends NCA3 print spreadsheet to States	State review NCA3 print spreadsheet, provide a yes or no for mailing
BLS sends NVS3, NCA3, and State contact information spreadsheet to print contractor	
NVS3, NCA3 mailing complete	
	States initiate procedures for delinquent reporters
	States send UI respondent email addresses to qualify for rebate
	Generate CCS edit 1a and 1b, send to regional office
May	
BLS uploads ARS transmittal 12	States process ARS data from transmittal 12, and send the SMR by the 25 th
	Generate CCS edit 1a and 1b, send to regional office
NVM Web closes for 1Q	
June	
BLS uploads ARS transmittal 13 and 14. Transmittal 14 is the final of the ARS year.	States process ARS data from transmittal 13 and 14, and send the SMR by the 25 th
ARS Web closes for the year	

Appendix F – Edit Conditions and Formulas

This appendix provides the edit specifications for all the required edits used in the standard state QCEW processing systems and in the BLS system. The edits are presented in edit code order, grouped by edit level. Frequently used formulas, symbols, and abbreviations appear first, followed by edit descriptions. The following information is provided for the edits:

<i>Descriptive Information</i>	<i>Explanation</i>
General Description:	Identifies the data element or elements being edited, and gives the basic purpose of the edit.
Location:	Tells whether the edit is performed in state systems, the BLS system, or both.
Level:	Micro (the Unemployment Insurance/Reporting Unit Number (UI/RUN) record is edited), macro (the county-ownership-industry cell is edited), or both.
Edit Level:	Every edit is included in an edit level, based on its purpose and on the severity of the error or flag. The characteristics of each edit level are explained in the body of the appendix, just before the edit descriptions for that level. There are nine edit levels: <ol style="list-style-type: none"> 1 Pre-edits (edits 001-006) 2 Key field (industry, county, ownership) invalid errors (010-017) 3 Date and status code invalid errors (021-025) 4 Remaining invalid errors (031-080) 5 Large record employment and wage edits (089-099) 6 Warning and other summed level edits (088, 101-146) 7 Predecessor/Successor edits (156-164) 8 Multi-establishment edits (171-185) 9 Wage record edits (193-198)
Edit Type:	Distinguishes between invalid (I) errors and warning (W) flags.
Priority:	A, B, or C. Priorities for correcting or explaining flagged data are discussed in Section 13.3.3.
BLS Edit Publ. Criteria:	Identifies whether a record is included in BLS publication aggregations if one of these edit flags exists. Include = ignore the flag and use the data. Exclude = do not use the record. Records with no edit flags are typically included in publication totals depending on their status code, coverage code, and possibly other factors.

<i>Descriptive Information</i>	<i>Explanation</i>
Edit Message:	The message typically displayed when the edit flag is assigned. Appendix G gives a complete list of edit messages arranged in order by edit code and grouped by edit level.
Edit Conditions:	The data conditions that cause the system to assign the flag. This section sometimes begins with bypasses: data conditions that cause the system to skip the edit and pass the record. The edit conditions are written in the form of system requirements, that is, as instructions to the computer.
Editing Parameters/Tolerances:	Parameters or tolerances (if any) used by the edit. These are displayed with italicized small capital letters. Appendix H provides a consolidated list of the parameters and tolerances for all the edits.
System Action:	Actions taken by state or BLS systems, if they take any action apart from flagging the record. For example, the system may replace invalid values with blanks.

Appendix B (Data Element Definitions) gives the purposes and uses of the data elements being edited, and describes the valid values and default values (where applicable).

Frequently Used Formulas

Average Monthly Employment (AME) is the sum of the three monthly employment fields divided by three:

$$AME = \frac{M1 + M2 + M3}{3}$$

Average Quarterly Wages (AQW) equals Total Wages (TW) divided by Average Monthly Employment:

$$AQW = \frac{TW}{AME}$$

(When AME = 0, then AQW = 0.)

Average Weekly Wages (AWW) equals Average Quarterly Wages divided by 13:

$$AWW = \frac{AQW}{13}$$

Frequently Used Symbols

Σ	sum of (for example, $\Sigma M1_{\text{sub}i} = M1_{\text{sub}1} + M1_{\text{sub}2} + \dots + M1_{\text{sub-last}}$)
	absolute value (for example, $ a - b $ or if $a = 3$ and $b = 5$, then $ 3 - 5 = -2 = 2$)
\geq	greater than or equal
\leq	less than or equal
\neq	not equal
\pm	plus or minus
\div	divided by (for example $AQW = TW \div AME$)
$\sqrt{\quad}$	may also be used to identify when taking a square root of a number or portion of a formulae (for example, $\sqrt{9} = 3$)
$n^{1/2}$	square root of n (for example, $9^{1/2} = \text{square root of } 9 = 3$)

Subscripts (letters with a lowered position) show which quarter's data are used:

- Subscripts of "c" represent the current quarter. For example, TW_c = Total Wages for the current quarter.
- Subscripts of "p" represent the prior quarter. For example, AQW_p = Average Quarterly Wages for the prior quarter.
- Subscripts of "cy" represent the quarter one year ago from the current quarter. For example, AME_{cy} = Average Monthly Employment from the quarter one year ago from the current quarter.
- Subscripts of "py" represent the quarter one year ago from the prior quarter. For example, $M1_{py}$ = First Month Employment from the quarter one year ago from the first month of the prior quarter.

Frequently Used Data Field Abbreviations:

AME	Average Monthly Employment
AQW	Average Quarterly Wages
ARS	Annual Refiling Survey
AWW	Average Weekly Wages
CNTY	County Code
CTB	Contributions Due
EOL	End of Liability Date

LIAB	Initial Liability Date
LWRC	Wage Record Count from Largest Wage Record Contributor (excluding self)
LWRR	Wage Record Count from Largest Wage Record Recipient (excluding self)
M1	First Month Employment
M2	Second Month Employment
M3	Third Month Employment
MEEI	Multi-establishment Employer Indicator
MOA	Mailing Other Address
MWRC	Matched Wage Record Count
OWN	Ownership Code
PLA	Physical Location Address
PRED	Predecessor
QTR	Reference Quarter
REACT	Reactivation Date
RUN	Reporting Unit Number
SETUP	Set-up Date
STATUS	Status Code
SUCC	Successor
TAXW	Taxable Wages
TOWN	Township Code
TW	Total Wages
UI#	UI Account Number
UIA	UI Address
YEAR	Reference Year

QTR refers to the quarter whose data are being edited. Processing quarter refers to the current quarter, i.e., the quarter treated as current by the processing system.

Edit Descriptions – Pre-edits

Pre-Edits ensure that each record's identifying information is properly formatted as numeric or alpha-numeric, has the expected values, and can be loaded to the BLS system. These errors rarely if ever occur in state systems since the data elements are usually system-controlled. These edits are important in the BLS system to ensure that the correct state's data are loaded to the database for the correct year and quarter and are processed as instructed by the state.

001 — Transaction Code Check

General Description: All micro records submitted to BLS on the Enhanced Quarterly Unemployment Insurance (EQUI) deliverable must have a valid Transaction Code. The Transaction Code identifies the type of record being submitted from the state to BLS. These codes are assigned by state systems when generating an EQUI file. The transaction codes are used by BLS to determine how to process the record. Valid codes are:

- D - delete record
- F - data record. "F" stands for full record, since all data records provide full data in every field, even if they only modify (update) selected fields.
- P - predecessor/successor record
- H - header record
- T - trailer record
- U - a selected number of records are submitted by BLS staff to resolve significant problems that must be corrected quickly for critical BLS users.
- Blank- partial record (no longer used)

Location: BLS only
Edit Level: 1
Priority: C

Level: Micro
Edit Type: Invalid
BLS Edit Publ. Criteria: N/A

Edit Message: *Invalid Transaction Code*

Edit Conditions:

- Flag if
- Transaction Code ≠ "D", "F", "P", "H", "T", "U", or blank.

002 — UI Account Number (UI#) Check

General Description: The UI Account Number edit checks for valid numeric values. The UI Account Number field must be numeric in all ten positions, and must not be zero-filled, nine-filled, or blank. The field should be right justified with unused positions zero-filled. If the structure of the UI Account Number is in any way different from the structure on the previous quarter's file, the state should provide a description of the changes and coordinate with the BLS prior to submitting the file.

Location: Both BLS & state system
 Edit Level: 1
 Priority: A

Level: Micro
 Edit Type: Invalid
 BLS Edit Publ. Criteria: N/A

Edit Message: *Invalid UI Account Number*

Edit Conditions:

Flag if

- UI # = all zeroes, all nines, all blanks, or contains a non-numeric value in any position

System Action: State systems will right justify and zero-fill any unused positions. State systems create files or printouts of those records, such as those with non-numeric UI account numbers, which cannot be loaded to their state system.

003 — Reporting Unit Number (RUN) Check

General Description: The Reporting Unit Number is a 5-digit field that must be numeric in every position. The field must be right justified with unused positions zero-filled. It can never be blank. It cannot be nine-filled, since “99999” is reserved for selected cases of the Predecessor RUN and Successor RUN fields.

Location: Both BLS & state systems
 Edit Level: 1
 Priority: A

Level: Micro
 Edit Type: Invalid
 BLS Edit Publ. Criteria: N/A

Edit Message: *Invalid Reporting Unit Number*

Edit Conditions:

Flag if either condition occurs

- RUN ≠ numeric in any position or
- RUN = 99999.

System Action: State systems will right-justify and zero-fill any unused positions. State systems create files or printouts of those records, such as those with non-numeric Reporting Unit Numbers, which cannot be loaded to their state system.

004 — Reference Year (YEAR) Check

General Description: The Reference Year is a four digit numeric field. This field helps ensure that only data for the reference period are entered into the correct year/quarter positions of the database.

Location: Both BLS & state system
 Edit Level: 1
 Priority: A

Level: Micro
 Edit Type: Invalid
 BLS Edit Publ. Criteria: N/A

Edit Message: *Invalid Reference Year***Edit Conditions:**

Flag if either condition occurs:

- YEAR \neq numeric in any positions or
- First two digits of YEAR \neq 19 or 20.

System Action: If the reference year/reference quarter combination is valid but does not correspond to the range of unlocked quarters, the BLS system will not load and process the record.

005 — Reference Quarter (QTR) Check

General Description: This edit checks the Reference Quarter field to verify that it is 1, 2, 3, or 4. This field helps ensure that only data for the reference period are entered into the correct quarterly portion of the database.

Location: Both BLS & state system

Edit Level: 1

Priority: A

Level: Micro

Edit Type: Invalid

BLS Edit Publ. Criteria: N/A

Edit Message: *Invalid Reference Quarter***Edit Conditions:**

Flag if

- QTR \neq 1, 2, 3, or 4.

System Action: If the reference year/reference quarter combination is valid but does not correspond to the range of unlocked quarters, the BLS system will not load and process the record.

006 — State Code Check

General Description: This edit checks for a valid State Federal Information Processing Standards (FIPS) Code in the BLS system. The State FIPS code is present on EQUI data records but is not required on the state files. The State Code must match a parameter (*STATE-FIPS-CODE*), to verify that the EQUI file is being processed for the correct state.

Location: BLS only

Edit Level: 1

Priority: A

Level: Micro

Edit Type: Invalid

BLS Edit Publ. Criteria: N/A

Edit Message: *Invalid State Code*

Edit Conditions:

Flag if

- STATE \neq STATE-FIPS-CODE.

Editing Parameters/Tolerances:

Parameter	Parameter Name	Length	EXPO PK #	WIN PK #	State Default	BLS Default
STATE-FIPS-CODE	State FIPS Code	2	N/A	N/A	Valid FIPS code of state being processed	Valid FIPS code of state being processed

Level 2 Edit Descriptions – Key Field Edits

Key fields, typically industry, ownership, and county, are essential classification fields which are most used for aggregation, sampling, and other data uses. Errors in these fields render a record fundamentally unusable.

010 — NAICS Code Check

General Description: The NAICS code check ensures that only valid codes under the North American Industry Classification System are used in the NAICS field on QCEW data files. Normally the NAICS Code is not edited for inactive records; however, it is edited when an inactive record in first quarter has a Response Code that may include it on the Code Change Supplement (CCS) for the same reference/refiling year.

Location: Both BLS & State systems
Edit Level: 2
Priority: A

Level: Micro
Edit Type: Invalid
BLS Edit Publ. Criteria: Exclude, if flagged

Edit Message: *Invalid NAICS Code*

Edit Conditions:

Bypass if STATUS = 3 or 9.
Bypass if STATUS = 2 and MEEI = 2.

Flag if both of the following conditions occur:

- STATUS ≠ 2, 3, or 9 and
- NAICS ≠ valid 6-digit NAICS.

Flag if all of the following conditions occur:

- QTR = 1 and
- STATUS = 2 and
- ARS REFILE YEAR = Current Refiling Year and
- (RESPONSE CODE = 46 or 50 in the state systems) or (RESPONSE CODE = 30, 33, 46 or 50 in the national office System) and
- NAICS ≠ valid 6-digit NAICS.

System Action: If data for 2016/4 or earlier, use 2012-based list of valid NAICS codes. If data for 2017/1 or later, use 2017-based list of valid NAICS codes. Note: Do not edit locked quarters or quarters beyond the maximum length of the correction policy.

012 — Ownership (OWN) Code Check

General Description: This edit flags the Ownership if it is not one of the following valid codes:

- 1 Federal Government
- 2 State Government
- 3 Local Government
- 5 Private Sector

Normally the Ownership Code is not edited for inactive records; however, it is edited when an inactive record in first quarter has a Response Code that may include it on the CCS for the same reference/refiling year.

Location: Both BLS & state system
Edit Level: 2
Priority: A

Level: Micro
Edit Type: Invalid
BLS Edit Publ. Criteria: Exclude, if flagged

Edit Message: *Invalid Ownership Code*

Edit Conditions:

- Bypass if STATUS = 3 or 9.
- Bypass if STATUS = 2 and MEEI = 2.

Flag if both of the following conditions occur:

- STATUS \neq 2, 3, or 9 and
- OWN \neq 1, 2, 3, or 5.

Flag if all of the following conditions occur:

- QTR = 1 and
- STATUS = 2 and
- ARS REFILE YEAR = Current Refiling Year and
- (RESPONSE CODE = 46 or 50 in the state systems) or (RESPONSE CODE = 30, 33, 46 or 50 in the BLS System) and
- OWN \neq 1, 2, 3, or 5.

Note: Do not edit locked quarters or quarters beyond the maximum length of the correction policy.

013 — County (CNTY) Code Check

General Description: The County Code must be a valid FIPS county code for the state, or one of the valid county equivalent codes: 995, 996, 998, or 999. Master records may carry code 900. Normally the County Code is not edited for inactive records; however, it is edited when an inactive record in first quarter has a Response Code that may include it on the CCS for the same reference/refiling year.

Location: Both BLS & state systems
Edit Level: 2
Priority: A

Level: Micro
Edit Type: Invalid
BLS Edit Publ. Criteria: Exclude, if flagged

Edit Message: *Invalid County Code*

Edit Conditions:

Bypass if STATUS = 3 or 9.
Bypass if STATUS = 2 and MEEI = 2.

Flag if all of the following conditions occur:

- STATUS ≠ 2, 3, or 9 and
- MEEI = 1, 3, 4, 5, or 6 and
- (CNTY ≠ valid county FIPS code) or (CNTY ≠ 995, 996, 998, or 999).

Flag if all of the following conditions occur:

- STATUS ≠ 2, 3, or 9 and
- MEEI = 2 and
- (CNTY ≠ valid county FIPS code) or (CNTY ≠ 900, 995, 996, 998, or 999).

Flag if all of the following conditions occur:

- QTR = 1 and
- STATUS = 2 and
- ARS REFILE YEAR = Current Refiling Year and
- (RESPONSE CODE = 46 or 50 in the state systems) or (RESPONSE CODE = 30, 33, 46 or 50 in the BLS System) and
- MEEI = 1, 3, 4, 5, or 6 and
- (CNTY ≠ valid county FIPS code) or (CNTY ≠ 995, 996, 998, or 999).

Note: Do not edit locked quarters or quarters beyond the maximum length of the correction policy.

016 — Ownership/NAICS Conflict

General Description: The Ownership/NAICS Conflict edit looks for situations in which the ownership and NAICS are incompatible. Normally NAICS and Ownership Codes (and their combinations) are not edited for inactive records; however, they are edited when an inactive record in first quarter has a Response Code that may include it on the CCS for the same reference/refiling year.

Location: Both BLS & state systems

Edit Level: 2

Priority: A

Level: Micro

Edit Type: Invalid

BLS Edit Publ. Criteria: Exclude, if flagged

Edit Message: *NAICS & Ownership Inconsistent*

Edit Conditions:

Bypass if STATUS = 3 or 9.

Bypass if STATUS = 2 and MEEI = 2.

Flag if (STATUS ≠ 2, 3, or 9) and any of the following conditions occur:

- (NAICS = 814110 and OWN ≠ 5) or
- ((NAICS = 921110 — 921140) and OWN = 5) or
- ((NAICS = 921190 — 928120) and OWN = 5) or
- (NAICS = 921150 and OWN ≠ 5 and Year ≤ 2000) or
- (NAICS = 921150 and OWN ≠ 3 and Year ≥ 2001) or
- (NAICS = 521110 and OWN = 2 or 3) or
- (NAICS = 551111 — 551114 and OWN = 1, 2, or 3) or
- (NAICS = 491110 and OWN = 2 or 3).

Flag if all of the following conditions occur:

- QTR = 1 and
- STATUS = 2 and
- ARS REFILE YEAR = Current Refiling Year and
- (RESPONSE CODE = 46 or 50 in the State Systems) or (RESPONSE CODE = 30, 33, 46 or 50 in the BLS System) and
- Any of the following conditions occur:
 - (NAICS = 814110 and OWN ≠ 5) or
 - ((NAICS = 921110 — 921140) and OWN = 5) or
 - ((NAICS = 921190 — 928120) and OWN = 5) or
 - (NAICS = 921150 and OWN ≠ 5 and Year ≤ 2000) or
 - (NAICS = 921150 and OWN ≠ 3 and Year ≥ 2001) or
 - (NAICS = 521110 and OWN = 2 or 3) or
 - (NAICS = 551111 — 551114 and OWN = 1, 2, or 3) or
 - (NAICS = 491110 and OWN = 2 or 3).

Note: Do not edit locked quarters or quarters beyond the maximum length of the correction policy.

Level 3 Edit Descriptions – Date and Status Code Edits

The Date and Status Code edits are used to ensure that the record has adequate information to properly determine its status. These fields are used to determine whether or not the record should be edited, refiled, aggregated, and provided to various state and BLS users.

The year portion of the Liability Date, End of Liability Date, Set Up Date, and Reactivation Date is a four-digit numeric field. Note that state extract programs can use 1935 as the lowest valid value for any year starting with 19.

021 — Liability Date Format Check

General Description: For single and master records, this is the date that an employer became subject to UI reporting requirements; it is assigned by UI. For worksites, this is the date they were first reported on the Multiple Worksite Report (MWR) or alternate MWR data collection modes. The edit checks that the field, if provided, is numeric in every position and is properly formatted as a date.

Both the EXPO and WIN systems use Liability, Reactivation, and End of Liability dates to override most Status Code procedures and or settings. Liability dates and End of Liability dates are also used to determine if a particular month of employment should be imputed or if the wages should be adjusted for a shorter quarterly work period.

Location: Both BLS & state systems

Edit Level: 3

Priority: C

Level: Micro

Edit Type: Invalid

BLS Edit Publ. Criteria: Include, if flagged

Edit Message: *Invalid Initial Liability Date Format*

Edit Conditions:

Format = YYYYMMDD (where YYYY = year, MM = month, and DD = day).

Bypass if LIAB blank.

Bypass if OWN = 1.

Bypass if STATUS = 2, 3, or 9.

Flag if any of the following conditions are met:

- MM = 0 or > 12, or
- DD = 00, or
- First two digits of the year ≠ “19” or “20,” or
- YYYYMMDD is non-numeric in any positions but not all blank

System Action: If the values are non-numeric (other than blank) or all zeros, the systems (both state and BLS) will change the values to blanks. If the day positions (DD) are blank but the rest of the field (YYYYMM) is not blank, the EXPO and WIN systems will change DD to 01. If MM = 02 and DD > 29, the EXPO and WIN systems will set DD = 28. If MM = 04, 06, 09 or 11 and DD > 30, the EXPO and WIN systems will set DD = 30. If MM = 01, 03, 05, 07, 08, 10, or 12 and DD > 31, the EXPO and WIN systems will set DD = 31. If an invalid date is entered online the state system will require that it be corrected.

022 — End of Liability Date Format Check

General Description: The End of Liability Date (sometimes called the Termination Date) is assigned by UI for single and master records showing when an employer no longer has employment or wages, ceases to be active, or is no longer operating. For worksites, it is the closest date available showing when the establishment closed. The edit checks that the field, if provided, is numeric in every position and is properly formatted as a date.

Both the EXPO and WIN systems use Liability, Reactivation, and End of Liability dates to override most Status Code procedures and or settings. Liability dates and End of Liability dates are also used to determine if a particular month of employment should be imputed or if the wages should be adjusted for a shorter quarterly work period.

Location: Both BLS & state systems

Edit Level: 3

Priority: C

Level: Micro

Edit Type: Invalid

BLS Edit Publ. Criteria: Include, if flagged

Edit Message: *Invalid EOL Date Format*

Edit Conditions:

Format = YYYYMMDD (where YYYY = year, MM = month, and DD = day).

Bypass if EOL blank.

Bypass if STATUS = 3 or 9.

Bypass if OWN = 1.

Flag if any of the following conditions are met:

- MM = 0 or > 12, or
- DD = 00, or
- First two digits of the year ≠ “19” or “20,” or
- YYYYMMDD is non-numeric in any positions but not all blank

System Action: If the values are non-numeric (other than blank) or all zeros, the systems (both state and BLS) will change the values to blanks. If the day positions (DD) are blank but the rest of the field (YYYYMM) is not blank, the EXPO and WIN systems will change DD to 28. If MM = 02 and DD > 29, the EXPO and WIN systems will set DD = 28. If MM = 04, 06, 09 or 11 and DD > 30, the EXPO and WIN systems will set DD = 30. If MM = 01, 03, 05, 07, 08, 10, or 12 and DD > 31, the EXPO and WIN systems will set DD = 31. If an invalid date is entered online the state system will require that it be corrected.

023 — Setup Date Format Check

General Description: The Setup Date shows when the reporting unit entered the state UI system. Typically it should not be missing (blank) for singles or masters, but may be missing for subunits. The edit checks that the field, if provided, is numeric in every position and is properly formatted as a date.

Location: Both BLS & state systems
Edit Level: 3
Priority: C

Level: Micro
Edit Type: Invalid
BLS Edit Publ. Criteria: Include, if flagged

Edit Message: *Invalid Set-Up Date Format*

Edit Conditions:

Format = YYYYMMDD (where YYYY = year, MM = month, and DD = day).

Bypass if SETUP is blank.

Bypass if STATUS = 2, 3, or 9.

Bypass if OWN = 1.

Flag if any of the following conditions are met:

- MM = 0 or > 12, or
- DD = 00, or
- First two digits of the year ≠ “19” or “20,” or
- YYYYMMDD is non-numeric in any positions but not all blank

System Action: If the values are non-numeric (other than blank) or all zeros, the systems (both state and BLS) will change the values to blanks. If the day positions (DD) are blank but the rest of the field (YYYYMM) is not blank, the EXPO and WIN systems will change DD to 01. If MM = 02 and DD > 29, the EXPO and WIN systems will set DD = 28. If MM = 04, 06, 09 or 11 and DD > 30, the EXPO and WIN systems will set DD = 30. If MM = 01, 03, 05, 07, 08, 10, or 12 and DD > 31, the EXPO and WIN systems will set DD = 31. If an invalid date is entered online, the state system will require that it be corrected.

024 — Reactivation Date Format Check

General Description: The Reactivation Date shows when an inactive unit in the UI system is reactivated. The interval between the End of Liability Date and the Reactivation Date will indicate the period of time the unit was not operating as a business. If a reactivated unit again ceases operations, its End of Liability Date should be updated. The edit checks that the field, if provided, is numeric in every position and is properly formatted as a date.

Both the EXPO and WIN systems use Liability, Reactivation, and End of Liability dates to override most Status Code procedures and or settings.

Location: Both BLS & state systems

Level: Micro

Edit Level: 3

Edit Type: Invalid

Priority: C

BLS Edit Publ. Criteria: Include, if flagged

Edit Message: *Reactivation Date Invalid or Earlier than Initial Liability Date*

Edit Conditions:

Format = YYYYMMDD (where YYYY = year, MM = month, and DD = day).

Bypass if REACT is blank.

Bypass if STATUS = 2, 3, or 9.

Bypass if OWN = 1.

Flag if any of the following conditions are met:

- MM = 0 or > 12, or
- DD = 00, or
- First two digits of the year ≠ “19” or “20,” or
- YYYYMMDD is non-numeric in any positions but not all blank

Flag if REACT < LIAB

System Action: If the values are non-numeric (other than blank) or all zeros, the systems (both state and BLS) will change the values to blanks. If the day positions (DD) are blank but the rest of the field (YYYYMM) is not blank, the EXPO and WIN systems will change DD to 01. If MM = 02 and DD > 29, the EXPO and WIN systems will set DD = 28. If MM = 04, 06, 09 or 11 and DD > 30, the EXPO and WIN systems will set DD = 30. If MM = 01, 03, 05, 07, 08, 10, or 12 and DD > 31, the EXPO and WIN systems will set DD = 31. If an invalid date is entered online the state system will require that it be corrected.

025 — Status Code Check

General Description: The Status Code edit check is used to ensure that the entries in the Status Code are valid:

- 1 = Active
- 2 = Inactive
- 3 = Not submitted on the EQUI for the reference quarter (used in the BLS system only)
- 9 = Pending

The Status Code is used as a quarterly data element in both state and BLS systems and is included on the EQUI file. This data element is critical for identifying active reporting units, because their economic data belong on the macro file and other data aggregations. Most other edits use the Status code, typically for bypassing inactive or pending records.

Location: Both BLS & state systems

Edit Level: 3

Priority: A

Level: Micro

Edit Type: Invalid

BLS Edit Publ. Criteria: Exclude, if flagged

Edit Message: *Invalid Status Code*

Edit Conditions:

Flag if STATUS \neq 1, 2, or 9 in state systems.

Flag if STATUS \neq 1, 2, 3, or 9 in BLS systems.

State System Action:

If the Liability Date and the End of Liability Date are the same valid date, but not blank, the state systems consider the record inactive and set the Status Code = 2.

If the record has a valid, non-blank Reactivation Date which is equal to the valid, non-blank End of Liability Date, the state systems consider the record active and set the Status Code = 1.

If the Liability Date, End of Liability Date, and Reactivation Date are valid, non-blank, and equal, the state systems consider the record active and set the Status Code = 1.

If the Reactivation Date is blank or earlier or equal to the End of Liability Date, and if the End of Liability Date is the first day of the quarter and the employment and wages fields have zeroes and "M" indicators, the state systems consider the record inactive and set the Status Code to 2.

WIN-202 System: If the End of Liability Date is the first day of the quarter (i.e., January 1, April 1, July 1, October 1) and the quarter of the End of Liability Date has employment, wages, and/or contributions > 0 , the End of Liability Date is changed to the second day of the quarter (i.e., January 2, April 2, July 2, October 2) and the status is set to Active (1).

EXPO System: EXPO gives its users the option to inactivate records that have not reported in six quarters even without an End of Liability Date. EXPO also has an option to reactivate records that were inactive and report positive data.

BLS and State Systems Action:

If the delete indicator is set to D, then change the Status Code to 2 on all unlocked quarters regardless of the End of Liability Date. Note: Unlocking older quarters will trigger this Status Code reset.

If the delete indicator is changed to blank in the state systems, the Status Code is changed to active in all unlocked quarters except those where a state analyst sets the Status Code to something other than 1 or the End of Liability Date is entered, triggering resetting of the Status Codes on unlocked quarters. These updates will mark EQUI updates for those quarters covered under the BLS correction policy.

BLS will update its files based on updated EQUI records submitted by the states.

Level 4 Edit Descriptions – Remaining Invalid Error Edits

Edits in this level review the data elements for:

- Valid numeric or alpha conditions
- Valid responses from a limited set of expected values
- Valid relationships between two or three data elements

In almost all cases, these edit flags must be corrected. There are a few situations where the state systems will override an invalid response with a blank, or will zero fill.

031 — First Month Employment (M1) Check

General Description: The monthly employment fields are numeric on both the state and BLS databases, and only numeric values may be entered.

Location: Both BLS & state systems

Edit Level: 4

Priority: A

Level: Micro

Edit Type: Invalid

BLS Edit Publ. Criteria: Exclude, if flagged

Edit Message: *Invalid First Month Employment*

Edit Conditions:

Bypass if STATUS = 2, 3, or 9.

Flag if M1 is not numeric.

In the BLS system, also flag if the M1-IND = X.

System Action: The state system right-justifies and zero-fills leading blanks. If non-numeric characters occur during initial entry to the system, the state system puts an “X” in the first month employment indicator field to signify a non-numeric entry, lists the non-numeric values, and zero-fills first month employment.

032 — Second Month Employment (M2) Check

General Description: The monthly employment fields are numeric on both the state and BLS databases, and only numeric values may be entered.

Location: Both BLS & state systems	Level: Micro
Edit Level: 4	Edit Type: Invalid
Priority: A	BLS Edit Publ. Criteria: Exclude, if flagged

Edit Message: *Invalid Second Month Employment*

Edit Conditions:

Bypass if STATUS = 2, 3, or 9.
Flag if M2 is not numeric.
In the BLS system, also flag if the M2-IND = X.

System Action: The state system right-justifies and zero-fills leading blanks. If non-numeric characters occur during initial entry to the system, the state system puts an “X” in the second month employment indicator field to signify a non-numeric entry, lists the non-numeric values, and zero-fills second month employment.

033 — Third Month Employment (M3) Check

General Description: The monthly employment fields are numeric on both the state and BLS databases, and only numeric values may be entered.

Location: Both BLS & state systems	Level: Micro
Edit Level: 4	Edit Type: Invalid
Priority: A	BLS Edit Publ. Criteria: Exclude, if flagged

Edit Message: *Invalid Third Month Employment*

Edit Conditions:

Bypass if STATUS = 2, 3, or 9.
Flag if M3 is not numeric.
In the BLS system, also flag if the M3-IND = X.

System Action: The state system right-justifies and zero-fills leading blanks. If non-numeric characters occur during initial entry to the system, the state systems puts an “X” in the third month employment indicator field to signify a non-numeric entry, lists the non-numeric values, and zero-fills third month employment.

034 — Total Wages (TW) Check

General Description: The Total Wages field is numeric on both the state and BLS databases, and only numeric values may be entered. The Total Wages edit checks for numeric values and no decimal places. The Total Wages field should contain whole dollar amounts only – round to next higher dollar if residual cents are greater than or equal to 50 cents.

Location: Both BLS & state systems	Level: Micro
Edit Level: 4	Edit Type: Invalid
Priority: A	BLS Edit Publ. Criteria: Exclude, if flagged

Edit Message: *Invalid Total Wages*

Edit Conditions:

Bypass if STATUS = 2, 3, or 9.
Flag if TW not numeric.
In the BLS system, also flag if the TW-IND = X.

System Action: The state system right-justifies and zero-fill leading blanks. If non-numeric characters occur during initial entry to the system, the state system puts an “X” in the Total Wages Indicator field to signify a non-numeric entry, lists the non-numeric values, and zero-fills Total Wages.

035 — Taxable Wages (TAXW) Check

General Description: The Taxable Wages field is numeric on both the state and BLS databases, and only numeric values may be entered. This edit checks for numeric values and no decimal places. The Taxable Wages field should contain whole dollar amounts only – round to next higher dollar if residual cents are greater than or equal to 50 cents.

Location: Both BLS & state systems	Level: Micro
Edit Level: 4	Edit Type: Invalid
Priority: A	BLS Edit Publ. Criteria: Exclude, if flagged

Edit Message: *Invalid Taxable Wages*

Edit Conditions:

Bypass if STATUS = 2, 3, or 9.
Flag if TAXW not numeric.

System Action: The state system right-justifies and zero-fills leading blanks. If non-numeric characters occur during initial entry to the system, the state system puts an “X” in the Taxable Wages Indicator field to signify a non-numeric entry, lists the non-numeric values, and zero-fills Taxable Wages.

036 — Contributions (CTB) Check

General Description: Contributions are not valid for Federal, reimbursable, or non-covered accounts. The Contributions field is numeric on both the state and BLS databases, and only numeric values may be entered. This edit checks for non-numeric values, including decimal places, as well as for non-zero Contributions on records with certain Type of Coverage or Ownership codes. This is because Contributions should not be present on reimbursable, non-covered, or Federal records. The Contributions field should contain whole dollar amounts only – round to next higher dollar if residual cents are greater than or equal to 50 cents.

Location: Both BLS & state systems

Edit Level: 4

Priority: A

Level: Micro

Edit Type: Invalid

BLS Edit Publ. Criteria: Exclude, if flagged

Edit Message: *Invalid Contributions*

Edit Conditions:

Bypass if STATUS = 2, 3, or 9.

Flag if any of the following occur:

- CTB not numeric or
- OWN = 1 and CTB > 0 or
- COVERAGE = 1, 8, or 9, and CTB > 0

System Action: The state system right-justifies and zero-fills leading blanks. If non-numeric characters occur during initial entry to the system, the state system puts an “X” in the Contributions Indicator field to signify a non-numeric entry, lists the non-numeric values, and zero-fills Contributions.

039 — Type of Coverage Check

General Description: This edit flags the Type of Coverage Code (sometimes called the Reimbursable Code) if it is not valid. A few states also collect employee contributions. In these cases, special Type of Coverage Codes were created to allow for additional contributions beyond the amount of Taxable Wages times the Employer Tax Rate.

Type of Coverage Code 8 (non-subject accounts) is valid in State systems, but not in BLS. Records with this code are excluded from the EQUI.

Location: Both BLS & State systems

Edit Level: 4

Priority: A

Level: Micro

Edit Type: Invalid

BLS Edit Publ. Criteria: Exclude, if flagged

Edit Message: *Invalid Type of Coverage*

Edit Conditions:

In state systems, flag if both conditions are met:

- STATUS \neq 2 or 9, and
- COVERAGE \neq 0, 1, 2, 3, 8, or 9.

In the BLS system, flag if both conditions are met:

- STATUS \neq 2, 3, or 9, and
- (COVERAGE \neq 0, 1, 2, 3, or 9) or (COVERAGE not valid for the state being edited).

040 — MEEI Code Check

General Description: This edit checks for valid values for the Multi Establishment Employer Indicator.

Location: Both BLS & state systems
Edit Level: 4
Priority: A

Level: Micro
Edit Type: Invalid
BLS Edit Publ. Criteria: Exclude, if flagged

Edit Message: *Invalid MEEI Code*

Edit Conditions:

Flag if both conditions are met:

- STATUS \neq 2, 3, or 9, and
- MEEI \neq 1, 2, 3, 4, 5, or 6.

043 — Predecessor UI Account Number or Predecessor Reporting Unit Number Check

General Description: The Predecessor UI Account Number edit checks for valid numeric values. The Predecessor UI Account Number must be numeric in all ten positions. It cannot be all zeros. The Predecessor UI Account Number is used to track a change of ownership between accounts and to link successor accounts to predecessor accounts.

The Predecessor Reporting Unit Number, if provided, must be numeric in all five positions.

Edit code 043 is used for both parts of the Predecessor SESA ID: the Predecessor UI Account Number and the Predecessor Reporting Unit Number.

Location: Both BLS & state systems
Edit Level: 4
Priority: B

Level: Micro
Edit Type: Invalid
BLS Edit Publ. Criteria: Include, if flagged

Edit Message: *Invalid Predecessor SESA ID*

Edit Conditions:

- Bypass if PRED UI# is blank.
- Bypass if PRED RUN is blank.

Bypass if STATUS = 2, 3, or 9.

Flag if PRED UI# includes nonnumeric values.

Flag if PRED RUN includes nonnumeric values.

System Action: If the Predecessor UI Account Number is reported, the state system will right-justify it and zero-fill unused positions.

If the Predecessor Reporting Unit Number is provided, the state system will right-justify it and zero-fill unused positions. If the Predecessor UI Account Number is blank, and the Predecessor Reporting Unit Number is all blank, the system will leave them as blank.

If all fifteen positions of the UI account and Reporting Unit Number are zeroes, the system will change it to all blanks in the BLS System. State systems should check that predecessor/successor transaction records do not have zero or blank predecessors or successors.

044 — Successor UI Account Number Check or Successor Reporting Unit Number Check

General Description: The Successor UI Account Number edit checks for valid numeric values. The Successor UI Account Number must be numeric in all ten positions. It cannot be all zeroes. The Successor UI Account Number is used to track a change of ownership between accounts and to link successor accounts to predecessor accounts.

The Successor Reporting Unit Number, if provided, must be numeric in all five positions.

Edit code 044 is used for both parts of the Successor SESA ID: the Successor UI Account Number and the Successor Reporting Unit Number.

Location: Both BLS & state systems

Edit Level: 4

Priority: B

Level: Micro

Edit Type: Invalid

BLS Edit Publ. Criteria: Include, if flagged

Edit Message: *Invalid Successor SESA ID*

Edit Conditions:

Bypass if SUCC UI# is blank.

Bypass if SUCC RUN is blank.

Bypass if STATUS = 3 or 9.

Flag if SUCC UI# includes nonnumeric values.

Flag if SUCC RUN includes nonnumeric values.

System Action: If the Successor UI Account Number is reported, the state system will right-justify it and zero-fill unused positions.

If the Successor Reporting Unit Number is provided, the state system will right-justify it and zero-fill unused positions. If the Successor UI Account Number is blank, and the Successor Reporting Unit Number is all blank, the system will leave them as blank.

If all fifteen positions of the UI account and Reporting Unit Number are zeroes, the system will change it to all blanks in the BLS System. State systems should check that predecessor/successor transaction records do not have zero or blank predecessors or successors.

045 — Federal Employer Identification Number (EIN) Check

General Description: This edit checks the EIN for invalid values including non-numeric, invalid prefixes, and values between 000000001 and 009999999. The EIN is assigned to each employer by the IRS and is used by BLS to link units of the same enterprise. Multi-establishment sub-units should have the same EIN as their master record. EINs are sometimes unavailable or unreliable for government units and private households. The list of valid prefixes will be periodically reviewed and updated as IRS updates their list of valid prefixes.

EINs are used extensively for sampling, multi-state matching and corporate linking, research, nondisclosure processing, Electronic Data Interchange (EDI) processing, etc. It is important that usable EINs be properly maintained.

Location: Both BLS & state systems
Edit Level: 4
Priority: A

Level: Micro
Edit Type: Invalid
BLS Edit Publ. Criteria: Include, if flagged

Edit Message: *Invalid Federal EI Number*

Edit Conditions:

- Bypass if STATUS = 2, 3, or 9.
- Bypass if NAICS = 814110.
- Bypass if COVERAGE = 8 or 9.

If EIN blank, change to zeroes and do edit 116 instead.

[In State systems only, if

- EIN has the first 2 digits of 70,
- Set EIN = 000000000.]

Flag if EIN is any of these values:

- One-filled (111111111) or
- Two-filled (222222222) or
- Three-filled (333333333) or
- Four-filled (444444444) or
- Five-filled (555555555) or
- Six-filled (666666666) or
- Seven-filled (777777777) or
- Eight-filled (888888888) or
- Nine-filled (999999999).

Flag if all of these conditions are met:

- AME > EIN-ERROR-AME and
- OWN = 5 and
- EIN is in the range of 000000001 - 009999999, inclusive.

Flag if all of these conditions are met:

- AME > EIN-ERROR-AME and
- OWN = 5 and
- EIN has the first 2 digits of: 07, 08, 09, 17, 18, 19, 28, 29, 49, 78, 79, or 89

In BLS edit system, flag if all of these conditions are met:

- AME > EIN-ERROR-AME and
- OWN = 5 and
- EIN has the first 2 digits of 70.

In BLS edit system, flag if EIN is nonnumeric in any position.

Editing Parameters/Tolerances:

Parameter	Parameter Name	Length	EXPO PK #	WIN PK #	State Default	BLS Default
EIN-ERROR-AME	Small Record EIN Parm	6	066	070	5	5

System Action: If EIN is all blank, the State systems zero fill the field. If EIN is all zeroes, the BLS and State systems bypass this check and perform the Missing Federal Employer Identification Number Check, code 116.

046 — ARS Response Code/Year Check

General Description: This edit ensures that the ARS Response Code and ARS Refile Year, if provided, are valid. These two data elements, in combination, show what refiling response the record last received and when it received that response. Their use is discussed in detail in Chapter 11; definitions for the ARS Response Code appear in Appendix Q. If either ARS Response Code or ARS Refile Year is present, both must be present. This edit is performed for inactive reporting units (with Status Code = 2) because they can be included on the CCS and therefore need accurate Response Code/ARS Refile Year combinations.

Location: Both BLS & state systems

Level: Micro

Edit Level: 4

Edit Type: Invalid

Priority: B

BLS Edit Publ. Criteria: Include, if flagged

Edit Message: *Invalid ARS Response Code/Year*

Edit Conditions:

Bypass if STATUS = 3 or 9.

Bypass if RESPONSE CODE and ARS REFILE YEAR are both blank.

Flag if

STATUS = 2 and (QTR = 1) and (in BLS system, the quarter is unlocked for CCS processing), and any of the following conditions occur:

- RESPONSE CODE is not blank nor a valid code (00, 01, 02, 03, 04, 11, 12, 30, 31, 32, 33, 34, 35, 41, 42, 43, 46, 50, 63, 64, 65, 86, 98, 99) or
- ARS REFILE YEAR is not numeric and not blank, or ARS REFILE YEAR is later than *FISCAL-YEAR* (the current refiling year) or
- (RESPONSE CODE is numeric but not 50 or) and the ARS REFILE YEAR is blank, or
- ARS REFILE YEAR is numeric but the ARS RESPONSE CODE is blank.

Flag if

STATUS ≠ 2, 3, or 9, and any of the following conditions occur:

- RESPONSE CODE not blank nor valid code (00, 01, 02, 03, 04, 11, 12, 30, 31, 32, 33, 34, 35, 41, 42, 43, 46, 50, 63, 64, 65, 86, 98, 99) or
- (ARS REFILE YEAR is not numeric and not blank) or (ARS REFILE YEAR is later than *FISCAL-YEAR*) or
- (RESPONSE CODE is numeric but not 50) and the ARS REFILE YEAR is blank, or
- ARS REFILE YEAR is numeric but the RESPONSE CODE is blank.

Editing Parameters/Tolerances:

Parameter	Parameter Name	Length	EXPO PK #	WIN PK #	State Default	BLS Default
<i>FISCAL-YEAR</i>	Fiscal Year	4	—	—	Processing or fiscal year for current refiling	Current processing year, or fiscal year for the refiling just completed

System Action: If the ARS Response Code = 50 and the ARS Refile Year is blank, the State systems will change the ARS Refile Year to the current fiscal year. The BLS system assigns Response Codes 33, 34, and 35 when the state-assigned Response Code is not appropriate given the code change information provided.

047 — Tax Rate Range Check

General Description: The Employer Tax Rate is a 5-position numeric field on state files. This edit checks the field values against the minimum and maximum tax rate parameters for non-Federal, non-reimbursing accounts. A valid Tax Rate is required to edit the non-reimbursable account Contributions. It is also used to impute any missing contributory Contributions.

Location: State only
Edit Level: 4
Priority: C

Level: Micro
Edit Type: Invalid
BLS Edit Publ. Criteria: N/A

Edit Message: *Invalid Tax Rate - Beyond Minimum/Maximum Range*

Edit Conditions:

Flag if all of the following conditions occur:

- STATUS ≠ 2 or 9, and
- COVERAGE = 0 or 2 and
- OWN > 1 and
- (RATE > MAX-TAX-RATE) or (RATE < MIN-TAX-RATE).

Editing Parameters/Tolerances:

Parameter	Parameter Name	Length	EXPO PK #	WIN PK #	State Default	BLS Default
<i>MAX-TAX-RATE</i>	Maximum Tax Rate	6	001	001	15% (expressed as 015000 in EXPO, 15.00 in WIN)	N/A
<i>MIN-TAX-RATE</i>	Minimum Tax Rate	6	002	002	0	N/A

048 — Comment Code Check

General Description: Three comment code fields of two positions each are available to provide clarifications relating to the data or to explain unusual data fluctuations. This edit checks all three fields. Unused comment code fields should be left blank. Current Employment Statistics (CES)-only comment codes are invalid for this edit. Comment code 99 may be used if a Narrative Comment is present on the record.

Location: Both BLS & state systems
Edit Level: 4
Priority: C

Level: Micro
Edit Type: Invalid
BLS Edit Publ. Criteria: Include, if flagged

Edit Message: *Invalid Comment Code*

Edit Conditions:

Bypass if COMMENT is all blank.

Flag if both conditions are met:

- STATUS ≠ 2, 3 or 9, and
- Any COMMENT = 37-38, 62-74, 84, or 94; or contains non-numeric values.

049 — First Month Employment Indicator Check

General Description: This edit checks that the one-position alpha-numeric First Month Employment Indicator field contains a valid entry. This data element describes whether the employment data were reported or imputed. If imputed, the indicator describes the type of imputation performed on the employment field.

Location: Both BLS & state systems
Edit Level: 4
Priority: C

Level: Micro
Edit Type: Invalid
BLS Edit Publ. Criteria: Include, if flagged

Edit Message: *Invalid First Month Employment Indicator*

Edit Conditions:

Flag if both conditions occur:

- STATUS ≠ 2, 3, or 9, and
- M1-IND ≠ R, A, C, D, E, H, K, L, M, N, P, S, W, X, or blank.

050 — Second Month Employment Indicator Check

General Description: This edit checks that the one-position alpha-numeric Second Month Employment Indicator field contains a valid entry. This data element describes whether the employment data were reported or imputed. If imputed, the indicator describes the type of imputation performed on the employment field.

Location: Both BLS & state systems	Level: Micro
Edit Level: 4	Edit Type: Invalid
Priority: C	BLS Edit Publ. Criteria: Include, if flagged

Edit Message: *Invalid Second Month Employment Indicator*

Edit Conditions:

Flag if both conditions occur:

- STATUS ≠ 2, 3, or 9, and
- M2-IND ≠ R, A, C, D, E, H, K, L, M, N, P, S, W, X, or blank.

051 — Third Month Employment Indicator Check

General Description: This edit checks that the one-position alpha-numeric Third Month Employment Indicator field contains a valid entry. This data element describes whether the employment data were reported or imputed. If imputed, the indicator describes the type of imputation performed on the employment field.

Location: Both BLS & state systems	Level: Micro
Edit Level: 4	Edit Type: Invalid
Priority: C	BLS Edit Publ. Criteria: Include, if flagged

Edit Message: *Invalid Third Month Employment Indicator*

Edit Conditions:

Flag if both conditions occur:

- STATUS ≠ 2, 3, or 9, and
- M3-IND ≠ R, A, C, D, E, H, K, L, M, N, P, S, W, X, or blank.

052 — Total Wages Indicator Check

General Description: This edit checks that the one-position alpha-numeric Total Wage Indicator field contains a valid entry. This data element describes whether the Total Wages data were reported or imputed. If imputed, the indicator describes the type of imputation performed on the Total Wages field.

Location: Both BLS & state systems	Level: Micro
Edit Level: 4	Edit Type: Invalid
Priority: C	BLS Edit Publ. Criteria: Include, if flagged

Edit Message: *Invalid Total Wages Indicator*

Edit Conditions:

Flag if both conditions occur:

- STATUS ≠ 2, 3, or 9, and
- TW-IND ≠ R, C, E, H, K, L, M, N, P, S, W, X, or blank.

053 — Taxable Wages Indicator Check

General Description: This edit checks that the one-position alpha-numeric Taxable Wages Indicator field contains a valid entry. This data element describes whether the Taxable Wages data were reported or imputed. If imputed, the indicator describes the type of imputation performed on the Taxable Wages field.

Location: State Only	Level: Micro
Edit Level: 4	Edit Type: Invalid
Priority: C	BLS Edit Publ. Criteria: N/A

Edit Message: *Invalid Taxable Wages Indicator*

Edit Conditions:

Flag if both conditions occur:

- STATUS ≠ 2 or 9, and
- TAXW-IND ≠ R, C, E, H, K, L, M, N, P, X, or blank.

054 — Contributions Due Indicator Check

General Description: This edit checks that the one-position alpha-numeric Contributions Indicator field contains a valid entry. This data element describes whether the Contributions data were reported or imputed. If imputed, the indicator describes the type of imputation performed on the Contributions field.

Location: State only	Level: Micro
Edit Level: 4	Edit Type: Invalid

Priority: C

BLS Edit Publ. Criteria: N/A

Edit Message: *Invalid Contributions Due Indicator*Edit Conditions:

Flag if both conditions occur:

- STATUS \neq 2 or 9, and
- CTB-IND \neq R, C, E, H, K, L, M, N, P, X, or blank.

056 — Federal/Type of Coverage Check

General Description: This edit verifies that all Federal government installations (Ownership Code 1) are coded with the appropriate Type of Coverage Code (code 9, Federal accounts covered under Unemployment Compensation for Federal Employees (UCFE)). These types of error conditions are rare but usually occur when new UCFE units are set up with the wrong Type of Coverage Code.

Location: Both BLS & state systems	Level: Micro
Edit Level: 4	Edit Type: Invalid
Priority: A	BLS Edit Publ. Criteria: Exclude, if flagged

Edit Message: *Inconsistent Ownership/Type of Coverage*Edit Conditions:

Flag if all of the following conditions are met:

- STATUS \neq 2, 3, or 9, and
- OWN = 1 and
- COVERAGE \neq 9

Flag if all of the following conditions are met:

- STATUS \neq 2, 3, or 9, and
- COVERAGE = 9, and
- OWN $>$ 1

057 — Federal/Taxable Wage Check

General Description: This edit verifies that Taxable Wages are not included on Federal government records. These problems are rare but sometimes occur because:

- Federal government data have projected Taxable Wages and Contributions from the UI Tax File or supplemental files
- Contributory accounts are incorrectly assigned the wrong ownership

Location: Both BLS & state systems Level: Micro
Edit Level: 4 Edit Type: Invalid
Priority: A BLS Edit Publ. Criteria: Exclude, if flagged

Edit Message: *Taxable Wages on Federal Record*

Edit Conditions:

Flag if all conditions are met:

- STATUS \neq 2, 3, or 9, and
- OWN = 1 or COVERAGE = 9, and
- TAXW > 0

058 — Federal/Contributions Check

General Description: This edit verifies that Contributions are not included on Federal government records. These problems are rare but sometimes occur because:

- Federal government data have projected Taxable Wages and Contributions from the UI Tax File or supplemental files
- Contributory accounts are incorrectly assigned the wrong ownership

Location: Both BLS & state systems Level: Micro
Edit Level: 4 Edit Type: Invalid
Priority: A BLS Edit Publ. Criteria: Exclude, if flagged

Edit Message: *Contributions on Federal Record*

Edit Conditions:

Flag if all conditions are met:

- STATUS \neq 2, 3, or 9, and
- OWN = 1 or COVERAGE = 9, and
- CTB > 0

059 — Coverage/Taxable Wage Check

General Description: This edit checks for inconsistencies between the Type of Coverage Code and the Taxable Wages field. The UI-covered Type of Coverage Code should be 0, 1, 2, 3, or 9 on the EQUI, and may be 8 (non-subject) on state files. The record is flagged if Taxable Wages are included on a reimbursable record, a reimbursable/employee-funded record, a federal government record, or on a non-covered record.

Location: Both BLS & state systems	Level: Micro
Edit Level: 4	Edit Type: Invalid
Priority: A	BLS Edit Publ. Criteria: Exclude, if flagged

Edit Message: *Taxable Wages > 0 for Non-Experience-Rated Record*

Edit Conditions:

Flag if all conditions are met:

- STATUS ≠ 2, 3, or 9, and
- COVERAGE = 1, 3, 8, or 9 and
- TAXW > 0

060 — Coverage/Contributions Check

General Description: This edit checks for inconsistencies between the Type of Coverage Code and the Contributions field. Contributions should be zero on reimbursing records without employee funding, federal government records, or on non-covered records. Contributions must not be included on an employer-funded reimbursing record or non-covered record.

Location: Both BLS & state systems	Level: Micro
Edit Level: 4	Edit Type: Invalid
Priority: A	BLS Edit Publ. Criteria: Exclude, if flagged

Edit Message: *Contributions > 0 for Non-Experience-Rated Record*

Edit Conditions:

Flag if all conditions are met:

- STATUS ≠ 2, 3, or 9, and
- COVERAGE = 1, 8, or 9, and
- CTB > 0

062 — Taxable > Total Wage Check

General Description: This edit ensures that the Taxable Wages are not greater than the Total Wages. This problem may infrequently occur during the imputation or proration processes or on the UI extract if there are rounding problems. Significant differences frequently occur when the employer incorrectly completes the Quarterly Contribution Report (QCR) or if there are possible scanning problems when reading the QCR.

Location: Both BLS & state systems	Level: Micro
Edit Level: 4	Edit Type: Invalid
Priority: A	BLS Edit Publ. Criteria: Exclude, if flagged

Edit Message: *Taxable Wages > Total Wages*

Edit Conditions:

Flag if both conditions are met:

- STATUS ≠ 2, 3, or 9, and
- TW < TAXW

063 — Contributions > Taxable Wages Check

General Description: This edit ensures that the Contributions are not greater than the Taxable Wages. The edit treats Pennsylvania differently to allow for its handling of employee contributions.

Location: Both BLS & state systems	Level: Micro
Edit Level: 4	Edit Type: Invalid
Priority: A	BLS Edit Publ. Criteria: Exclude, if flagged

Edit Message: *Contributions > Taxable Wages*

Edit Conditions:

Flag if all conditions are met:

- STATUS ≠ 2, 3, or 9, and
- STATE FIPS ≠ 42 and
- COVERAGE = 0 and
- TAXW < CTB

Flag if all conditions are met:

- STATE FIPS = 42 and
- COVERAGE = 2 or 3 and
- TAXW < CTB - (TW × EMPLOYEE-TAX-RATE)

Editing Parameters/Tolerances:

Parameter	Parameter Name	Length	EXPO PK #	WIN PK #	State Default	BLS Default
<i>EMPLOYEE-TAX-RATE</i>	Employee Tax Rate	6	051	003	3% (expressed as 3000 in EXPO and 3.00 in WIN)	3% (expressed as 003000)

064 — Inconsistent MEEI and Reporting Unit Number Check

General Description: This edit checks for consistency between the Reporting Unit Number and MEEI code. This check ensures that a master record or a single account (MEEI 1, 2, 4 or 6) has a Reporting Unit Number = 00000 and a sub-unit (MEEI 3 or 5) has a Reporting Unit Number greater than 00000.

This problem may occur as a single unit is converted to a multi-establishment reporter and the single unit's MEEI code is changed to 3 or 5. In these cases, the single unit should typically be changed to the master record, and separate records should be set up for each worksite as appropriate. The new worksites should have MEEI codes of 3 or 5 and Reporting Unit Numbers greater than 00000.

Location: Both BLS & state systems
Edit Level: 4
Priority: A

Level: Micro
Edit Type: Invalid
BLS Edit Publ. Criteria: Include, if flagged

Edit Message: *MEEI/RUN Inconsistent*

Edit Conditions:

Flag if all of the conditions are met:

- STATUS ≠ 2, 3, or 9, and
- MEEI = 1, 2, 4, or 6, and
- RUN > 00000

Flag if all of the conditions are met:

- STATUS ≠ 2, 3, or 9, and
- MEEI = 3 or 5, and
- RUN = 00000

065 — Inconsistent County and Township Codes Check

General Description: This edit checks for valid County code /Township code configurations for New England states (including, for this purpose, New Jersey). For these states, County/Township consistency editing verifies that the Township code on each record is valid for the specified county. Township codes can be used by any state; however, Township codes from Non-New England states are zero-filled on EQUI submittals. This edit is only performed for New England states (Connecticut, Maine, Massachusetts, New Hampshire, Rhode Island, Vermont), and New Jersey.

Location: Both state & BLS systems	Level: Micro
Edit Level: 4	Edit Type: Invalid
Priority: A	BLS Edit Publ. Criteria: Include, if flagged

Edit Message: *Inconsistent County/Township Combination*

Edit Condition (only for Township states):

- Bypass if STATUS is 3 or 9.
- Bypass if STATE ≠ 09, 23, 25, 33, 34, 44, or 50.

Flag if both of the following conditions are met:

- STATUS ≠ 2, 3, or 9, and
- TOWN ≠ valid for the associated STATE.

Flag if both of the following conditions are met:

- STATUS ≠ 2, 3, or 9, and
- CNTY and TOWN are inconsistent based on lookup tables.

These are valid combinations for county and township equivalent codes:

MEEI	County/Township	MEEI	County/Township
1-6	valid county/valid town combination	1-6	999/999
1-6	996/996	1-6	995/995
1-6	998/998	2	900/900

Flag if all of the following conditions are met:

- STATUS = 2 and
- QTR = 1 and
- MEEI ≠ 2 and
- ARS REFILE YEAR = current Refiling year and
- RESPONSE CODE = 30, 33, 46, or 50 and
- TOWN ≠ valid for the associated STATE.

Flag if all of the following conditions are met:

- STATUS = 2 and
- QTR = 1 and
- MEEI ≠ 2 and
- ARS REFILE YEAR = current Refiling year and
- RESPONSE CODE = 30, 33, 46, or 50 and
- CNTY and TOWN are inconsistent based on lookup tables.

These are valid combinations for county and township equivalent codes:

MEEI	County/Township	MEEI	County/Township
1, 3-6	valid county/valid town combination	1, 3-6	999/999
1, 3-6	996/996	1, 3-6	995/995
1, 3-6	998/998		

066 — Predecessor Account Format Check

General Description: This edit ensures that both the Predecessor Reporting Unit Number and the Predecessor UI Account Number are present, if one or the other is present. If the Predecessor UI Account Number is not blank, then the Predecessor Reporting Unit Number cannot be blank.

Location: Both BLS & state systems	Level: Micro
Edit Level: 4	Edit Type: Invalid
Priority: B	BLS Edit Publ. Criteria: Include, if flagged

Edit Message: *Invalid Format in Predecessor Account*

Edit Conditions:

Flag if all conditions are met:

- STATUS ≠ 2, 3, or 9, and
- PRED UI# ≠ blank and
- PRED RUN is blank and
- AME_C > PRED-SUCC-AME.

Flag if all conditions are met:

- STATUS ≠ 2, 3, or 9, and
- PRED RUN ≠ blank and
- PRED UI# is blank.

Editing Parameters/Tolerances:

Parameter	Parameter Name	Length	EXPO PK #	WIN PK #	State Default	BLS Default
PRED-SUCC-AME	Predecessor and Successor AME Cutoff	6	006	004	0	0

067 — Successor Account Format Check

General Description: This edit ensures that both the Successor Reporting Unit Number and the Successor UI Account Number are present, if one or the other is present. If the Successor UI Account Number is not blank, then the Successor Reporting Unit Number cannot be blank. This edit checks inactive records (Status Code = 2) because their Successor SESA IDs are often needed to link predecessors to successors.

Location: Both BLS & state systems Level: Micro
 Edit Level: 4 Edit Type: Invalid
 Priority: B BLS Edit Publ. Criteria: Include, if flagged

Edit Message: *Invalid Format in Successor Account*

Edit Conditions:

Flag if all conditions are met:

- STATUS \neq 3 or 9, and
- SUCC UI# \neq blank and
- SUCC RUN is blank and
- $AME_C > PRED-SUCC-AME$.

Flag if all conditions are met:

- STATUS \neq 3 or 9, and
- SUCC RUN \neq blank and
- SUCC UI# is blank.

Editing Parameters/Tolerances:

Parameter	Parameter Name	Length	EXPO PK #	WIN PK #	State Default	BLS Default
<i>PRED-SUCC-AME</i>	Predecessor And Successor AME Cutoff	6	006	004	0	0

070 — Address Edits

General Description: Records have as many as three possible addresses (physical location, Mailing/Other, and UI address). These addresses are field specific on the State and BLS Micro files and on the EQUI files. To pass this edit, records must contain one full, mailable address that meets postal regulations. To test for usability and mailable in at least one address, the system examines each address field separately, then blocks the fields together as an individual address, and then compares the blocked addresses to determine if any block meets all editing requirements.

An Address block is defined as having

- Street Line - 1
- Street Line - 2
- City
- State
- Zip Code
- Zip Extension.

If at least one address block passes the edits, then all flags are counted but only a limited number of fields (where appropriate) will be listed for review. If none of the address blocks pass the edits, the system will list all three addresses so that the reviewer will have all information readily available to resolve the address problems for that record. At least one full block must be corrected before the address data are acceptable. UI Addresses cannot be manually updated in State systems. Changes to UI addresses should be made through the UI Tax system or can be entered into the MOA addresses if not used for a different address.

Location: Both BLS & state systems

Edit Level: 4

Priority: A

Level: Micro

Edit Type: Invalid

BLS Edit Publ. Criteria: Include, if flagged

Edit Message: *No Useable Address*

Edit Conditions:

Bypass if STATUS = 2, 3, or 9.

Bypass if OWN = 1. (Continue if OWN > 1.)

1. Edit each field of all the addresses separately (the specifications are listed with each data field below for edits 102-114).
2. If all fields in the address block pass the individual edits, then the address block also passes.
3. If any field in the address block fails an edit, then the address block also fails:
 - the Physical Location address block fails if edits 102-104, or 114 are flagged or PLA is missing.
 - the Mailing/Other address block fails if edits 109-111 are flagged or Mailing/Other address is missing.
 - the UI address block fails if edits 106-108 are flagged or UI address is missing.
4. If all three address blocks are blank and if the record has an MEEI code of 3 or 5, then copy a clean, usable address from the master record, if possible, as described in the system actions below. Otherwise, flag the record with code 070.
5. If all 3 address blocks pass the edits, continue editing other fields or records, as appropriate.

6. Identify the address blocks that have flags. Pass or flag edit 070 based on the following table:

PLA address block (edits 102-104,114)	UIA address block (edits 106-108)	MOA address block (edits 109-111)	Flag edit 070?
Pass	Pass or flag or missing	Pass or flag or missing	Pass
Pass or flag or missing	Pass	Pass or flag or missing	Pass
Pass or flag or missing	Pass or flag or missing	Pass	Pass
Flag or missing	Flag or missing	Flag or missing	Pass if AME < ADDRESS-AME
Flag or missing	Flag or missing	Flag or missing	Flag if AME ≥ ADDRESS-AME

Editing Parameters/Tolerances:

Parameter	Parameter Name	Length	EXPO PK #	WIN PK #	State Default	BLS Default
ADDRESS-AME	Address Edit Cutoff	6	069	095	5	5

State System Actions:

1. If any address contains all zeroes in one of the following fields, the system will blank out the field: Street Address Line 1, Street Address Line 2, City, or State Abbreviation. (This system action occurs before editing.)
2. For any address, if Address Line 1 is blank but Address Line 2 is not, the State systems move the contents of Line 2 to Line 1. When the State systems print addresses onto forms, the system will not print a blank street address line.
3. When the State Abbreviation = ZZ or CN, the State systems do not print the ZZ or CN onto forms. (The country or province name/abbreviation required by the Post Office should be present at the end of the City field.)
4. For multis, if a master's Mailing/Other Address is present and passes all address edits, but any subunit has no useable address, then the State systems copy the Mailing/Other Address from the master to the subunit. Note that if a subunit had earlier been flagged for having no clean address, this system action should remove the flag.
5. For multis, if a master's Mailing/Other Address is unavailable, and its UI Address is present and passes all address edits, and any subunit has no useable address, then the State systems copy the UI Address from the master to the subunit's UI Address. Note that if a subunit had earlier been flagged for having no clean address, this system action should remove the flag.

072 — Blank Name Check

General Description: This edit ensures that either a Trade Name (DBA) or a Legal Name is present on each record. An employment parameter is used. This allows some leeway particularly for new accounts where complete information may not be immediately available.

Location: Both BLS & state systems Level: Micro
 Edit Level: 4 Edit Type: Warning
 Priority: A BLS Edit Publ. Criteria: Include, if flagged

Edit Message: *Both Trade Name and Legal Name are Blank*

Edit Conditions:

Flag if all conditions are met:

- STATUS ≠ 2, 3, or 9, and
- AME > NAME-AME and
- TRADE NAME blank and
- LEGAL NAME blank.

Editing Parameters/Tolerances:

Parameter	Parameter Name	Length	EXPO PK #	WIN PK #	State Default	BLS Default
NAME-AME	Name AME	6	070	096	3	3

State System Action:

When printing forms, if Trade Name and Legal Name are the same, the system only prints one name.

074 — Old Ownership Code Check

General Description: This edit verifies that the non-quarterly Old Ownership field, if present, contains a valid code. Where the record has a valid Ownership code in the most recent fourth quarter and fourth quarter is active, the system uses this code to update the Old Ownership. The Old Ownership is essential for generating the CCS file. This edit is only performed when the Response Code, ARS Refile Year, and MEEI code qualify the record for the CCS. MEEI 2 records are not included on the CCS.

Location: Both BLS & state systems Level: Micro
 Edit Level: 4 Edit Type: Invalid
 Priority: B BLS Edit Publ. Criteria: Include, if flagged

Edit Message: *Invalid Old Ownership*

Edit Conditions:

Bypass if QTR = 1 and STATUS = 3.

Bypass if ARS REFILE YEAR \neq FISCAL-YEAR.

Bypass if RESPONSE CODE \neq 30, 33, 46, or 50.

Bypass if MEEI of the most recent first quarter = 2 or if the MEEI of the most recent fourth quarter = 2.

[In BLS system only: Bypass if OLD OWN is blank.]

Flag if OLD OWN \neq 1, 2, 3, or 5.

Editing Parameters/Tolerances:

Parameter	Parameter Name	Length	EXPO PK #	WIN PK #	State Default	BLS Default
FISCAL-YEAR	Fiscal Year	4	—	—	Processing or fiscal year for current refiling	Current processing year, or fiscal year for the refiling just completed

System Action: If Old Ownership is invalid or not equal to the valid fourth quarter Ownership, the State systems replace the Old Ownership with the valid, active fourth quarter Ownership code in the year prior to the refile year. If CCS is locked, the system will not run this edit.

075 — Old County Code Check

General Description: This edit verifies that the non-quarterly Old County field, if present, contains a valid code. Where the record has a valid County code in the most recent fourth quarter and fourth quarter is active, the system uses this code to update the Old County. The Old County is essential for generating the CCS file. This edit is only performed when the Response Code, ARS Refile Year, and MEEI code qualify the record for the CCS. MEEI 2 records are not included on the CCS.

Location: Both BLS & state systems

Edit Level: 4

Priority: B

Level: Micro

Edit Type: Invalid

BLS Edit Publ. Criteria: Include, if flagged

Edit Message: *Invalid Old County*

Edit Conditions:

Bypass if QTR = 1 and STATUS = 3.

Bypass if ARS REFILE YEAR \neq FISCAL-YEAR.

Bypass if RESPONSE CODE \neq 30, 33, 46, or 50.

Bypass if MEEI of the most recent first quarter = 2 or if the MEEI of the most recent fourth quarter = 2.

[In BLS system only: Bypass if OLD COUNTY is blank.]

Flag if OLD CNTY \neq valid County code nor 995, 996, 998, nor 999.

Editing Parameters/Tolerances:

Parameter	Parameter Name	Length	EXPO PK #	WIN PK #	State default	BLS Default
<i>FISCAL-YEAR</i>	Fiscal Year	4	—	—	Processing or fiscal year for current refiling	Current processing year, or fiscal year for the refiling just completed

System Action: If Old County is invalid or not equal to the valid fourth quarter County, the State systems replace the Old County with the valid, active fourth quarter County code in the year prior to the refile year. If the CCS is locked, the system will not run this edit.

076 — Old County/Township Code Check

General Description: This edit verifies that the non-quarterly Old Township field, if present, is valid and consistent with the Old County code. This edit is only used for New England states (including, for this purpose, New Jersey). Where the record has a valid Township code in the most recent fourth quarter and fourth quarter is active, the system uses this code to update the Old Township. The Old Township is used for generating the CCS file in New England states and New Jersey. This edit is only performed when the Response Code, ARS Refile Year, and MEEI code qualify the record for the CCS. MEEI 2 records are not included on the CCS.

Location: Both BLS & state systems

Level: Micro

Edit Level: 4

Edit Type: Invalid

Priority: B

BLS Edit Publ. Criteria: Include, if flagged

Edit Message: *Invalid Old County/Old Township Combination*

Edit Conditions:

Bypass if QTR = 1 and STATUS = 3.

Bypass if ARS REFILE YEAR \neq *FISCAL-YEAR* (the current refiling year).

Bypass if RESPONSE CODE \neq 30, 33, 46, or 50.

Bypass if the state is not Connecticut, Maine, Massachusetts, New Hampshire, Rhode Island, Vermont, or New Jersey (if STATE \neq 09, 23, 25, 33, 34, 44, or 50).

Bypass if MEEI of the most recent first quarter = 2 or if the MEEI of the most recent fourth quarter = 2.

In BLS system only: Bypass if OLD CNTY and OLD TOWN are blank.

Flag if the OLD CNTY/OLD TOWN combination is not a valid county/township combination for the state or is not an acceptable combination of county/township equivalent codes.

These are valid combinations for county and township equivalent codes:

MEEI	County/Township	MEEI	County/Township
1, 3-6	valid county/valid town combination	1, 3-6	999/999
1, 3-6	996/996	1, 3-6	995/995
1, 3-6	998/998		

Editing Parameters/Tolerances:

Parameter	Parameter Name	Length	EXPO PK #	WIN PK #	State default	BLS Default
<i>FISCAL-YEAR</i>	Fiscal Year	4	—	—	Processing or fiscal year for current refiling	Current processing year, or fiscal year for the refiling just completed

System Action: If Old Township is invalid or not equal to the valid fourth quarter Township, the state systems replace the Old Township with the valid, active fourth quarter Township code in the year prior to the refile year. If the CCS is locked, the system will not run this edit.

078 — Old NAICS Code Check

General Description: This edit verifies that the non-quarterly Old NAICS field, if present, contains a valid code. Where the record has a valid NAICS code in the most recent fourth quarter and fourth quarter is active, the system uses this code to update the Old NAICS field. The Old NAICS is used for generating the CCS file. This edit is only performed when the Response Code, ARS Refile Year, and MEEI code qualify the record for the CCS. MEEI 2 records are not included on the CCS.

Location: Both BLS & state systems
 Edit Level: 4
 Priority: B

Level: Micro
 Edit Type: Invalid
 BLS Edit Publ. Criteria: Include, if flagged

Edit Message: *Invalid Old NAICS Code*

Edit Conditions:

- Bypass if QTR = 1 and STATUS = 3.
- Bypass if ARS REFILE YEAR ≠ *FISCAL-YEAR*.
- Bypass if RESPONSE CODE ≠ 30, 33, 46, or 50.
- Bypass if MEEI of the most recent first quarter = 2 or if the MEEI of the most recent fourth quarter = 2.
- [In BLS system only: Bypass if OLD NAICS is blank.]

Flag if OLD NAICS \neq valid 6-digit 2017-based NAICS code in 2018/1 processing.

Editing Parameters/Tolerances:

Parameter	Parameter Name	Length	EXPO PK #	WIN PK #	State Default	BLS Default
FISCAL- YEAR	Fiscal Year	4	—	—	Processing or fiscal year for current refiling	Current processing year, or fiscal year for the refiling just completed

System Action: If Old NAICS is invalid or not equal to the valid fourth quarter NAICS, the state systems replace the Old NAICS with the valid, active fourth quarter NAICS code in the year prior to the refile year. If the CCS is locked, the system will not run this edit.

080 — Indian Tribal Indicator Ownership/NAICS Conflict Check

General Description: The Indian Tribal Ownership/NAICS Conflict edit looks for situations in which the ownership and/or NAICS is/are incompatible with the Special Indicator value T (Indian Tribal Council). When the Special Indicator T is used, the ownership code should always be 3. Also, when the NAICS code is 921150, the Special Indicator should be a T. Note that it is possible for records in ownership 3 with many other NAICS codes to be valid with a Special Indicator of T as well. For instance, a federally recognized tribe running a gambling casino would be coded in 713210 and ownership 3 with a special indicator of T. Note also that edit 016 checks the NAICS and ownership combination for industry 921150.

Location: Both BLS & state systems

Edit Level: 4

Priority: A

Level: Micro

Edit Type: Invalid

BLS Edit Pub Criteria: Include, if flagged

Edit Message: *Indian Tribal Indicator Inconsistent with NAICS or OWN*

Edit Conditions:

Flag if all conditions are met:

- STATUS \neq 2, 3, or 9 and
- SPECIAL INDICATOR = T and
- OWN \neq 3.

Flag if all conditions are met:

- STATUS \neq 2, 3, or 9 and
- NAICS = 921150 and
- SPECIAL INDICATOR \neq T

085 — Potential Predecessor Check

General Description: An existing or new account receives a significant number of its employees from one primary contributing account based on information from matching wage records. A check of wage records show that many of the wage records were previously reported to, but no longer report to, a different account. That previous wage records reporter may be a potential predecessor to the account being edited.

Location: Both BLS & state systems

Level: Micro

Edit Level: 5

Edit Type: Warning

Priority: A

BLS Edit Publ. Criteria: Include, if flagged

Edit Message: *Potential Predecessor (UI#) found based on Wage Records*

EXPO and WIN Edit Conditions:

Flag if all conditions are true:

- $OWN_c = 5$
- $STATUS_c \neq 2$ or 9
- $MEEI_c \neq 3$ or 5
- $COVERAGE_c = 0$
- Each of the 6 earlier quarters has either
M1-IND, M2-IND, and M3-IND = R, C, E, H, K, M, N, X, or blank
OR
STATUS = 2 or 9 (In other words, the earlier quarters may be a combination of =
R, C, E, H, K, M, N, X, or blank employment indicators or STATUS 2 or 9)
- $AME_c > POTENTIAL-PS-EMP$
- No positively identified predecessor information (ignore possible predecessors) is found for the current time period in the predecessor/successor or other files.
- $LWRC_c$ (reported to account in current quarter but reported to someone else in the prior quarter) $> AME_c \times PPS-EMP\%$

If flagged, bypass edits 096 and 139.

BLS Edit Conditions:

Flag if all conditions are true:

- $OWN_c = 5$
- $STATUS_c \neq 2, 3,$ or 9
- $MEEI_c \neq 3$ or 5
- $COVERAGE_c = 0$
- Each of the 6 earlier quarters has either
M1-IND, M2-IND, and M3-IND = R, C, E, H, K, M, N, X, or blank
OR

STATUS = 2, 3, or 9 (In other words, the earlier quarters may be a combination of = R, C, E, H, K, M, N, X, or blank employment indicators or STATUS 2, 3, or 9)

- $AME_c > POTENTIAL-PS-EMP$
- No supplemental predecessor/successor records in current quarter that identify one or more predecessors
- $LWRC_C > AME_c \times PPS-EMP\%$

If flagged, bypass edits 096 and 139.

System Actions: (1) Display the UI account of the possible predecessor LWRC UI either in the error message, on the listing output, or on the on-line edit screen. (2) Allow states to run these edits separately or at a different time than the rest of the edits since they are dependent upon access to wage record information which may be available later in the edit cycle. (3) Exclude the reference account from being its own predecessor.

Editing Parameters/Tolerances:

Parameter	Parameter Name	Length	EXPO PK #	WIN PK #	State Default	BLS Default
<i>POTENTIAL-PS-EMP</i>	Potential Predecessor/ Successor Employment	6	086	N/A	100	100
<i>PPS-EMP%</i>	Potential Predecessor/ Successor Employment Percentage	6	087	N/A	75	75

086 — Potential Successor Check

General Description: An existing account is delinquent or possibly inactive. Many or all of the wage records reported to an account in a prior quarter are now reported by one different, primary receiving account in the current quarter. The recipient of those wage records may be a potential successor.

Location: Both BLS & state systems
 Edit Level: 5
 Priority: A

Level: Micro
 Edit Type: Warning
 BLS Edit Publ. Criteria: Include, if flagged

Edit Message: *Potential Successor (UI #) found based on Wage Records*

EXPO and WIN Edit Conditions:

Flag if all conditions are true:

- $OWN_p = 5$
- $STATUS_p \neq 2$ or 9
- $MEEI_p \neq 3$ or 5
- $COVERAGE_p = 0$
- The current quarter has either
M1-IND, M2-IND, and M3-IND = R, C, E, H, K, M, N, X, or blank
OR
STATUS = 2 or 9 (In other words, the current quarter may be a combination of =
R, C, E, H, K, M, N, X, or blank employment indicators or STATUS 2 or 9)
- $AME_p > POTENTIAL-PS-EMP$
- No positively identified successor information (ignore possible successors) is found for the current time period in the predecessor/successor or other files.
- $LWRR_C$ (reported to account in prior quarter but reported to different account in the current quarter) $> AME_p \times PPS-EMP\%$

If flagged, bypass edits 097 and 140.

BLS Edit Conditions:

Flag if all conditions are true:

- $OWN_p = 5$
- $STATUS_p \neq 2, 3,$ or 9
- $MEEI_p \neq 3$ or 5
- $COVERAGE_p = 0$
- The current quarter has either
M1-IND, M2-IND, and M3-IND = R, C, E, H, K, M, N, X, or blank
OR
STATUS = 2, 3, or 9 (In other words, the current quarter may be a combination of
= R, C, E, H, K, M, N, X, or blank employment indicators or STATUS 2, 3, or 9)
- $AME_p > POTENTIAL-PS-EMP$
- No supplemental predecessor/successor records in current quarter that identify one or more successors
- $LWRR_C > AME_p \times PPS-EMP\%$

If flagged, bypass edits 097 and 140.

System Actions: (1) Display the UI account of the possible successor either in the error message, on the listing output, or on the on-line edit screen. (2) Allow states to run these edits separately or at a different time than the rest of the edits since they are dependent upon access to wage record information which may be available later in the edit cycle. (3) Exclude the reference account from being its own successor.

Editing Parameters/Tolerances:

Parameter	Parameter Name	Length	EXPO PK #	WIN PK #	State default	BLS Default
<i>POTENTIAL-PS-EMP</i>	Potential Predecessor/ Successor Employment	6	086	N/A	100	100
<i>PPS-EMP%</i>	Potential Predecessor/ Successor Employment Percentage	6	087	N/A	75	75

088 — Large Record without Usable PLA Check

General Description: Each record has as many as three possible addresses (physical location, Mailing/Other, and UI address). These addresses are field specific on the State and BLS Micro files and on the EQUI files. To pass this edit, records must contain a full Physical Location address that can be geocoded. To test for usability and the ability to geocode the Physical Location Address, the system examines each address field separately, then blocks the fields together as an individual address, and then compares the blocked address to determine if it meets all editing requirements.

A Physical Location Address block is defined as having

- PLA Street Line - 1
- PLA Street Line - 2
- PLA City
- PLA State
- PLA Zip Code
- PLA Zip Extension.

Location: Both BLS & state systems

Level: Micro

Edit Level: 6

Edit Type: Warning

Priority: B

BLS Edit Publ. Criteria: Include, if flagged

Edit Message: *Large Record Without Usable PLA*

Edit Conditions:

Bypass if STATUS = 2, 3, or 9.

Bypass if OWN = 1-3. (Continue if OWN = 5.)

Bypass if MEEI = 2, 4 or 5.

Bypass if CNTY = 995, 996, 998, or 999

Bypass if AME < *LARGE-PLA-ADDRESS-AME-CUTOFF*

Flag if either condition is met:

- All of the PL address fields are blank or missing, or
- The record's PL address is flagged for any other PLA edit (for edit 102, 103, 104, or 114).

Editing Parameters/Tolerances:

Parameter	Parameter Name	Length	EXPO PK #	WIN PK #	State default	BLS Default
<i>LARGE-PLA-ADDRESS-AME</i>	Large PLA Address Cutoff	6	080	099	100	100

State System Actions:

If the PLA contains all zeroes in one of the following fields, the system will blank out the field: Street Address Line 1, Street Address Line 2, City, or State Abbreviation. (This system action occurs before editing.)

Level 5 Edit Descriptions – Large Record Employment and Wage Edits

Several of the employment and wage edits are divided into significant changes (Level 5) and important but not as large changes (Level 6). This was done to help reviewers focus first on those changes that have the greatest impact on the data. Most of these edits are performed at both the micro and macro level.

These edits identify

- Fluctuations over time in employment or wages,
- Significantly large new or discontinued records,
- Records with high wages but no employment, or
- Records with high employment but no wages.

Most of these records warrant further review, possible corrections, and usually some explanation if not corrected. Problems can be researched

- Using wage records,
- Using UI correspondences or supplemental information,
- Using similar units of a multi-establishment employer, similar employers in the cell, or
- By contacting the employer.

089 — Large Monthly Employment Change Check - Month 1 (WIN-202)

General Description: Edits 089 and 136 look for unusual employment fluctuations in month 1 employment. Larger fluctuations flag with code 089, while smaller (but still questionable) fluctuations flag with code 136. These two edits are only used in the WIN-202 System (EXPO and BLS use 091 and 126 instead).

See edit 091 for a full description.

Location: WIN-202 System only
Edit Level: 5

Level: Micro
Edit Type: Warning

Priority: A

BLS Edit Publ. Criteria: Include, if flagged

Edit Message: *Month 1 Employment Change Greatly Exceeds Test Parameters*

Edit Conditions: See Edit 091 in this section for details and parameter values

090 — Large Monthly Employment Change Check - Month 2 (WIN-202)

General Description: Edits 090 and 137 look for unusual employment fluctuations in month 2 employment. Larger fluctuations flag with code 090, while smaller (but still questionable) fluctuations flag with code 137. These two edits are only used in the WIN-202 System (EXPO and BLS use 091 and 126 instead).

See edit 091 for a full description.

Location: WIN-202 System only

Level: Micro

Edit Level: 5

Edit Type: Warning

Priority: A

BLS Edit Publ. Criteria: Include, if flagged

Edit Message: *Month 2 Employment Change Greatly Exceeds Test Parameters*

Edit Conditions: See Edit 091 in this section for details and parameter values.

091 — Large Monthly Employment Change Check

General Description: Edit 091 looks for unusual employment fluctuations. The edit works differently in the WIN-202 System, so the general description is broken out below by system.

EXPO and BLS System: Edits 091 and 126 look for unusual employment fluctuations in all three months of employment. The largest fluctuations flag with edit code 091, while smaller (but still questionable) fluctuations flag with code 126. The edit is performed three times for any given record, once for each month of employment in the quarter. The monthly employment edit consists of six different tests. If all steps that can be performed fail for any one of those months, the edit is flagged with either 91 or 126. This edit is performed at both the micro and macro levels. The edit description for 091 is quite lengthy, and includes an example to illustrate the process. ***This edit is attempted three times for any given record, once for each month of employment in the current quarter. If all steps that can be performed fail for any one of those months, the edit is flagged with either 091 or 126.***

WIN-202 System: Edits 091 and 138 look for unusual employment fluctuations in month 3 employment. Larger fluctuations flag with code 091, while smaller (but still questionable) fluctuations flag with code 138. This edit consists of six different tests. If all steps that can be performed fail for month 3 employment, the edit is flagged with either 091 or 138. This edit is performed at both the micro and macro levels. (Fluctuations in month 1 employment are covered by edit 089 and 136, and fluctuations in month 2 are covered by edits 090 and 137.)

Location: Both BLS & state systems
 Edit Level: 5
 Priority: A

Level: Micro & Macro
 Edit Type: Warning
 BLS Edit Publ. Criteria: Include, if flagged

Edit Message:**EXPO and BLS:** *Employment Change Greatly Exceeds Test Parameters***WIN-202:** *Month 3 Employment Change Greatly Exceeds Test Parameters*Definitions:

AME = (month 1 employment + month 2 employment + month 3 employment)/3

AME_y = AME from the quarter one year ago from the current quarter

MC = employment of the current quarter month that is being tested (month 1, month 2, or month 3)

MC_y = employment of the month one year ago from MC (if MC = month 1 employment, MC_y = month 1 employment one year ago; if MC = month 2 employment, MC_y = month 2 employment one year ago; and if MC = month 3 employment, MC_y = month 3 employment one year ago)

MP = month preceding MC (if MC = month 1 employment, MP = month 3 employment of the prior quarter; if MC = month 2 employment, MP = month 1 employment of the current quarter; and if MC = month 3 employment, MP = month 2 of the current quarter)

Subscripts of c refer to the current quarter

Subscripts of y refer to the quarter one year ago from the current quarter (e.g., MC_y = current month, one year ago)

Subscripts of p refer to the prior quarter

F.3.1 Micro Edit Conditions

Edit Conditions:

Bypass the edit if STATUS = 2, 3, or 9 in the current quarter.

A. SMALL RECORD BYPASS

Condition:

- $\text{Max}(M1_p, M2_p, M3_p, M1_c, M2_c, M3_c) < \text{SMALL-REC-BYPASS}$

If the condition is true, bypass the edit. (stop - do not fail this edit for any of the three months of employment.)

If the condition is false, go to B. (Continue to 'NO HISTORY BYPASS'.)

B. NO HISTORY BYPASS

Condition:

- All 4 prior quarters have either of the following occur:
 - M1-IND and M2-IND and M3-IND = M, N, or X
 - OR
 - STATUS = 2, 3, or 9

If the condition is true, bypass the edit (stop - does not fail this edit for any of the three months of employment. This record may receive 096 or 139. See edit 096 for details.)

If the condition is false, continue with the C, PRELIMINARY STEP.'

EXPO and BLS: Steps C through J are performed on all three months of employment
WIN-202: Steps C through J are performed only on month 3 employment.

C. PRELIMINARY STEP

(i) Conditions:

- Employment indicator code for current month one year ago (MC_y-IND) = M, N, or X and MC_y = 0
- Employment indicator code for preceding month (MP-IND) = M, N, or X and MP = 0

If both conditions are true, continue with step (ii) of 'preliminary step'

If either of the conditions is false, go to D (continue with 'step 1')

(ii) Conditions:

- $|MC - MP| \geq EMPL-DIFF-SPL-AME \times EMPL-CHECK-MULTIPLIER$ (regardless of MP-IND)
- $LOW-EMPL-MAX-DIFF < |MC-MP| < EMPL-DIFF-SPL-AME \times EMPL-CHECK-MULTIPLIER$

If the 1st condition is true, flag with edit code 091 for that month.

If the 2nd condition is true, flag with edit code 126 in EXPO and BLS or 138 in WIN-202 for that month.

If both conditions are false, bypass the rest of the edit for that month (stop - does not fail this edit for month being tested).

D. STEP 1 – Current Month to preceding month -- absolute change

(i) Condition:

- Employment indicator code for preceding month (MP-IND) = M, N, or X

If the condition is true, go to G (bypass steps 1, 2, and 3 and continue with 'step 4')

If the condition is false, continue with step (ii) of 'step 1'

(ii) Conditions:

1)

- $AME_p < EMPL-DIFF-SPL-AME$
- $|MC - MP| > LOW-EMPL-MAX-DIFF$

OR

2)

- $AME_p \geq EMPL-DIFF-SPL-AME$
- $|MC - MP| > HIGH-EMPL-MAX-DIFF$

If either pair of conditions is true, go to E (continue with 'step 2').

If both pairs of conditions are false, bypass the rest of the edit (stop - does not fail this edit for month being tested).

E. STEP 2 – Current month to preceding month -- percent change

Conditions:

1) If both of the following occur:

- Number of months where M1-IND, M2-IND, and M3-IND \neq M, N, or X and STATUS = 1 from the four prior quarters \geq 6, and
- $| (MC - MP) | > HIGH-REPORTING-PCT-CHG \times MP$

OR

2) If both of the following occur:

- Number of months where M1-IND, M2-IND, and M3-IND \neq M, N, or X and STATUS = 1 from the four prior quarters $<$ 6
- $| (MC - MP) | > REPORTING-PCT-CHG \times MP$

If 1st condition is true, go to F (continue with 'step 3').

If 2nd condition is true, go to G (bypass 'step 3' and continue with 'step 4').

If both pairs of conditions are false, bypass the rest of the edit (stop - does not fail this edit for month being tested).

F. STEP 3 – T-test

Identify the largest employment value and smallest employment value in the four prior quarters. Exclude months with an employment indicator code MX-IND of M, N, or X or STATUS \neq 1.

Let RANGE = Largest Employment Value in four prior quarters – Smallest Employment Value in four prior quarters.

Determine T-Value from table where n = total number of available months in four prior quarters (include only months with employment indicator code MX-IND ≠ M, N, or X and STATUS = 1).

<u>n</u>	<u>T-Value</u>
6	2.571
7	2.447
8	2.365
9	2.306
10	2.262
11	2.228
12	2.201

Let $M_TOL = T\text{-Value} \times \sqrt{2} \times (RANGE/6)$

Condition:

- $|MC - MP| > M_TOL$

If condition is true, go to G (continue with 'step 4').

If condition is false, bypass the rest of the edit (stop - does not fail this edit for month being tested).

G. STEP 4 – Current month to year-ago month -- absolute change

(i) Condition:

- Employment indicator code for current month one year ago ($MC_y\text{-IND}$) = M, N, or X

If the condition is true, go to J (bypass steps 4, 5, and 6 and continue to 'determining edit level')

If the condition is false, continue with step (ii) of 'step 4'

(ii) Conditions:

(1)

- $AME_y < EMPL\text{-DIFF}\text{-SPL}\text{-AME}$
- $|MC - MC_y| > LOW\text{-EMPL}\text{-MAX}\text{-DIFF}$

OR

(2)

- $AME_y \geq EMPL\text{-DIFF}\text{-SPL}\text{-AME}$
- $|MC - MC_y| > HIGH\text{-EMPL}\text{-MAX}\text{-DIFF}$

If either pair of conditions is true, go to H (continue with 'step 5')

If both pairs of conditions are false, bypass the rest of the edit (stop - does not fail this edit for month being tested)

H. STEP 5 – Current month to year ago month -- percent change

Conditions:

(1)

- Number of available months employment in previous four quarters ≥ 6 (include only months with M1-IND, M2-IND, and M3-IND \neq M, N, or X and STATUS = 1)
- $|(MC - MC_y)| > HIGH-REPORTING-PCT-CHG \times MC_y$

OR

(2)

- Number of available months' employment in previous four quarters < 6 (include only months with employment indicator code MX-IND \neq M, N, or X and STATUS = 1)
- $|(MC - MC_y)| > REPORTING-PCT-CHG \times MC_y$

If condition (1) is true, go to I (continue with 'step 6')

If condition (2) is true, go to J (continue to 'determining edit level')

If both pairs of conditions are false, bypass the edit (stop - does not fail this edit for month being tested)

I. STEP 6 – Current month to year-ago month -- t-test

Condition:

- $|MC - MC_y| > M_TOL$ (M_TOL is defined in 'step 3')

If condition is true, go to J (continue to 'determining edit level')

If condition is false, continue with the following comparison between the First Month of the Current Quarter and the Last Month of the Prior Quarter:

Conditions:

- $|M1_c - M3_p| > BETWEEN-QUARTERS-ABS-DIFF$
- $|M1_c - M3_p| > BETWEEN-QUARTERS-PERCENT-DIFF \times M3_p$

Defaults for the parms are $BETWEEN-QUARTERS-ABS-DIFF = 500$ and $BETWEEN-QUARTERS-PERCENT-DIFF = 0.10$

If both conditions are true, go to J (continue to 'determining edit level')

If either of the conditions is false, bypass the edit (stop - does not fail this edit for month being tested).

J. DETERMINING EDIT LEVEL

Condition:

- $|MC - MP| > EMPL-DIFF-SPL-AME \times EMPL-CHECK-MULTIPLIER$

If condition is true, flag with edit 091.

If condition is false, flag with edit 126 in EXPO and BLS and 138 in WIN-202.

EXPO and BLS: If one of the three months receives a 091 or a 126, the record receives that edit code. If one month receives a 091 and another receives a 126, the record receives a 091.

WIN-202: Edits 089/136 and 090/137 follow these same rules. Anything receiving what would have been a 091/138 edit had it been month 3 employment would receive a 089/136 in month 1 or a 090/137 in month 2.

EDITING UPDATES TO PREVIOUS QUARTERS

States extract or update data **up to four quarters** earlier than the current processing quarter. Updates include corrections to reported data and the replacement of estimates with reported data. However, there are limited quarters of historical data available on the database. Since all updates should be edited, even if they are from four quarters back, the normal micro edits described earlier do not have enough historical data available to perform all the tests. If fewer tests were performed, a record would have fewer opportunities to pass the edits. This would cause updates to the earliest quarters to be more likely to flag. Therefore, the data that are used to edit back quarters will not be restricted to data from prior to the quarter being edited, but may also include quarters that are more recent than the quarter being reviewed.

A. Quarters to Use for T-Test (Steps 3 and 6)

For the t-test, the editing of updates to previous quarters may involve using data from any of the historical quarters on the file. Twelve months of data must be used to perform the test. The following table shows which quarters to use when performing the t-test.

For example, if the current quarter was 2018/1 and an update was made to 2017/3, the T-Test would use data from 2018/1, 2017/4, 2017/2, and 2017/1 to edit the updated record.

<i>Quarters to Use</i>	<i>Quarter Being Updated</i>				
	Current – 1	Current – 2	Current – 3	Current – 4	Current – 5
Current		X	X	X	
Current – 1		X	X	X	X
Current – 2	X		X	X	X
Current – 3	X	X		X	X
Current – 4	X	X	X		X
Current – 5	X				

B. Quarter to Use for Seasonality Test (Steps 4 and 5)

For the seasonality test portion of the employment edit, the updated employment data must be compared to data from the same month from the quarter either four quarters before or four quarters after the quarter being edited. Thus, for updates to the two oldest quarters on the file, the comparison will be to the quarter that is four quarters after the updated quarter. For the quarter that immediately precedes the current quarter, the comparison will be to the quarter that is four quarters before the updated quarter. The following table illustrates the appropriate quarters that are used. Note that the seasonality test cannot be performed for updates to the quarters that precede the current quarter by two or three quarters.

<i>Quarters to Use</i>	<i>Quarter Being Updated</i>				
	Current – 1	Current – 2	Current – 3	Current – 4	Current – 5
Current				X	
Current – 1					X
Current – 2					
Current – 3					
Current – 4					
Current – 5	X				

Micro Editing Parameters/Tolerances:

Parameter	Parameter Name	Length	EXPO PK #	WIN PK #	State default	BLS Default
<i>SMALL-REC-BYPASS</i>	Small Record Bypass	2	071	085	25	25
<i>EMPL-CHECK-MULTIPLIER</i>	Employment Check Multiplier	2	053	010	10	10
<i>EMPL-DIFF-SPL-AME</i>	Split Level For Employment Difference	2	010	005	20	20
<i>LOW-EMPL-MAX-DIFF</i>	Low Employment Maximum Employment Difference	2	011	006	15	15
<i>HIGH-EMPL-MAX-DIFF</i>	High Employment Maximum Employment Difference	2	012	007	40	40
<i>HIGH-REPORTING-PCT-CHG</i>	Employment Percent Change Limit For > 6 Reported Months	2	013	008	10	10
<i>REPORTING-PCT-CHG</i>	Employment Percent Change Limit For < 6 Reported Months	2	014	009	30	30
<i>BETWEEN-QUARTERS-ABS-DIFF</i>	Between quarters absolute difference	6	081	100	500	500
<i>BETWEEN-QUARTERS-PERCENT-DIFF</i>	Between quarters percent difference	2	082	101	0.10	0.10

F.3.2 Macro Edit Conditions

A. SMALL RECORD BYPASS

(i) Condition:

- $\text{Max}(M1_c, M2_c, M3_c, M1_p, M2_p, M3_p) < \text{SMALL-MACRO-REC-BYPASS}$

If the condition is true, bypass the edit (stop - does not fail this edit for any of the 3 months)

If the condition is false, continue to step (ii) of the pre-edit

(ii) Let NumEstab_c = number of establishments in the current quarter with non-zero total wages
or at least one non-zero month of employment

Let NumEstab_p = number of establishments in the prior quarter with non-zero total wages or
at least one non-zero month of employment

Let $\text{NumEstablMultiplier} = 0.5 \times \text{MIN}(\text{NumEstab}_c, \text{NumEstab}_p)$

If $\text{NumEstablMultiplier} < 1$, let $\text{NumEstablMultiplier} = 1$

Else let $\text{NumEstablMultiplier} = \text{Round}(\text{NumEstablMultiplier})$
{rounding is done to the nearest whole number}

If $\text{NumEstablMultiplier} > \text{NUM-ESTABL-LIMIT}$, let $\text{NumEstablMultiplier} = \text{NUM-ESTABL-LIMIT}$

Go to B (continue with 'pre-edit').

EXPO AND BLS: Steps B through I are performed on all three months of employment!

WIN-202: Steps B through I are performed on month 3 only!

B. PRE-EDIT

Conditions:

(1)

- Each of the four prior quarters has Number of Establishment = 0

OR

(2)

- Each of the two prior quarters has Number of Establishments = 0
- $M_c = \text{First Non-Zero Emp}$
- $M_c < \text{NONZERO-EMPL-CUTOFF}$

OR

(3)

- Each of the two prior quarters has Number of Establishments = 0

- $M_C = 0$

If (1) OR (2) OR (3) is true, bypass the edit. (Stop - does not fail this edit for month being tested.)

If both conditions are false, go to C. (Continue with 'step 1.')

EXPO and BLS: If the first nonzero month of employment is month 1 and the number of establishments in the two prior quarters is zero, continue to edit month 2 and month 3 through edits 091/126. If the first nonzero month of employment is month 2, continue to edit month 3 through edits 091/126.

C. STEP 1 - Minor Fluctuation Test—Absolute Difference:

Conditions:

(1)

- $AME_p < (\text{NumEstablMultiplier} \times \text{EMPL-DIFF-SPL-AME})$
- $|MC - MP| > (\text{NumEstablMultiplier} \times \text{LOW-EMPL-MAX-DIFF})$

OR

(2)

- $AME_p \geq (\text{NumEstablMultiplier} \times \text{EMPL-DIFF-SPL-AME})$
- $|MC - MP| > (\text{NumEstablMultiplier} \times \text{HIGH-EMPL-MAX-DIFF})$

If either pair of conditions is true go to D. (Continue with 'step 2.')

If both pairs of conditions are false, bypass the edit. (Stop - does not fail this edit for month being tested.)

D. STEP 2 - Minor Fluctuation Test—Percent Change:

Conditions:

(1)

- Number of available months (including month 1, month 2, and month 3) of available employment (in quarters where the number of establishments > 0) from the four prior quarters ≥ 6
- $|MC - MP| > (\text{HIGH-REPORTING-PCT-CHG} \times MP)$

OR

(2)

- Number of available months (including month 1, month 2, and month 3) of available employment (in quarters where the number of establishments > 0) from the four prior quarters < 6
- $|MC - MP| > (\text{REPORTING-PCT-CHG} \times MP)$

If (1) is true, go to E. (Continue with 'step 3.')

If (2) is true, go to F. (Continue with 'step 4.')

If both (1) and (2) are false, bypass the edit. (Stop - does not fail this edit for month being tested.)

E. STEP 3 - t-test:

- Identify the largest monthly employment value and smallest monthly employment value in the 12 months in the four prior quarters. Exclude months in quarters with Number of Establishments = 0.
- Let RANGE = largest employment value in four prior quarters– smallest employment value in four prior quarters

Determine t-Value from table where n = total number of available months in four prior quarters (excluding months in quarters with Number of Establishments = 0)

<u>n</u>	<u>T-Value</u>
6	2.571
7	2.447
8	2.365
9	2.306
10	2.262
11	2.228
12	2.201

- Let $M_TOL = t\text{-Value} \times \sqrt{2} \times (RANGE/6)$

Condition:

- $|MC - MP| > M_TOL$

If the condition is true, go to F. (Continue with 'step 4.')

If the condition is false, bypass the edit. (Stop - does not fail this edit for month being tested.)

F. STEP 4 - Seasonality Fluctuation Test—Absolute Difference:

Conditions:

(1)

- $AME_y < (\text{NumEstablMultiplier} \times EMPL\text{-}DIFF\text{-}SPL\text{-}AME)$
- $|MC - MC_y| > (\text{NumEstablMultiplier} \times LOW\text{-}EMPL\text{-}MAX\text{-}DIFF)$

OR

(2)

- $AME_y \geq (\text{NumEstablMultiplier} \times \text{EMPL-DIFF-SPL-AME})$
- $|\text{MC} - \text{MC}_y| > (\text{NumEstablMultiplier} \times \text{HIGH-EMPL-MAX-DIFF})$

If either pair of conditions is true, go to G. (Continue with 'step 5.')

If both pairs of conditions are false, bypass the edit. (Stop - does not fail this edit for month being tested.)

G. STEP 5 - Seasonality Fluctuation Test—Percent Change:

Conditions:

(1)

- Number of available months employment (number of establishments in the quarter \neq zero) ≥ 6
- $|\text{MC} - \text{MC}_y| > \text{HIGH-REPORTING-PCT-CHG} \times \text{MC}_y$

(2)

- Number of available months employment (including month 1, month 2, and month 3) of available employment (in quarters where the number of establishments > 0) from the 4 prior quarters < 6
- $|\text{MC} - \text{MC}_y| > \text{REPORTING-PCT-CHG} \times \text{MC}_y$

If 1st condition is true, go to H. (Continue with 'step 6.')

If 2nd condition is true, go to I. (Skip 'step 6' and continue with 'edit level.')

If both pairs of conditions are false, bypass the edit. (Stop - does not fail this edit for month being tested.)

H. STEP 6 - Seasonality t-test:

Condition:

- $|\text{MC} - \text{MC}_y| > \text{M_TOL}$ where (M_TOL is defined in 'step 3')

If condition is true, go to I. (Continue to 'determining edit level.')

If condition is false, bypass the edit. (Stop - does not fail this edit for month being tested.)

I. DETERMINING EDIT LEVEL

Condition:

- $|\text{MC} - \text{MP}| > (\text{NumEstablMultiplier} \times \text{EMPL-DIFF-SPL-AME} \times \text{EMPL-CHECK-MULTIPLIER})$

If the condition is true, flag with edit 091.

If the condition is false, flag with edit 126 in EXPO and BLS or 138 in WIN.

EXPO and BLS: If one of the three months receives a 091 or a 126, the record receives that edit code. If one month receives a 091 and another receives a 126, the record receives a 091.

WIN: Edits 089/136 and 090/137 follow these same rules. Anything receiving what would have been a 091/138 edit had it been month 3 employment would receive a 089/136 in month 1 or a 090/137 in month 2.

CODE CHANGE INTEGRATION

Editing macro data across years may be impacted by noneconomic code changes. For example, a large micro record that changed its industry in first quarter due to a noneconomic code change could cause a large and apparently unexplained change in a macro cell; the micro record would be in a different macro cell, and the macro cell it came from could have a precipitous drop in employment. To adjust for cases like this, the first quarter data are temporarily adjusted to eliminate the effect of the code changes only when the first quarter is the processing quarter (the quarter being edited). This adjustment is based on the net change for the cell from the Summary of Differences file, described in Chapter 11. (The only exception to this occurs when there are two first quarters on the file and the update is to the older first quarter. Whenever this occurs, there is no CCS or Summary of Differences file for that quarter, so the data cannot be adjusted.) Non-adjusted data are maintained on the files. If the second quarter of the current year is the processing quarter, both the first and second quarter data for the current year are left unadjusted and edited as described in the earlier tables.

EDITING UPDATES TO PREVIOUS QUARTERS

States extract or update data *up to four quarters* earlier than the current processing quarter. Updates include corrections to reported data and the replacement of estimates with reported data. However, there are limited quarters of historical data available on the database. Since all updates should be edited, even if they are from four quarters back, the normal macro edits described earlier do not have enough historical data available to perform all the tests. If fewer tests were performed, a record would have fewer opportunities to pass the edits. This would cause updates to the earliest quarters to be more likely to flag. Therefore, the data that are used to edit back quarters will not be restricted to data from prior to the quarter being edited, but may also include quarters that are more recent than the quarter being reviewed.

A. Quarters to Use for T-Test (Steps 3 and 6)

For the t-test, the editing of updates to previous quarters may involve using data from any of the historical quarters on the file. Twelve months of data must be used to perform the test. The following table shows which quarters to use when performing the t-test.

For example, if the current quarter was 2018/1 and an update was made to 2017/3, the t-test would use data from 2018/1, 2017/4, 2017/2, and 2017/1 to edit the updated record.

<i>Quarters to Use</i>	<i>Quarter Being Updated</i>				
	Current – 1	Current – 2	Current – 3	Current – 4	Current – 5
Current		X	X	X	
Current – 1		X	X	X	X
Current – 2	X		X	X	X
Current – 3	X	X		X	X
Current – 4	X	X	X		X
Current – 5	X				

B. Quarter to Use for Seasonality Test (Steps 4 and 5)

For the seasonality test portion of the employment edit, the updated employment data must be compared to data from the same month from the quarter either four quarters before or four quarters after the quarter being edited. Thus, for updates to the two oldest quarters on the file, the comparison will be to the quarter that is four quarters after the updated quarter. For the quarter that immediately precedes the current quarter, the comparison will be to the quarter that is four quarters before the updated quarter. The following table illustrates the appropriate quarters that are used. Note that the seasonality test cannot be performed for updates to the quarters that precede the current quarter by two or three quarters.

<i>Quarters to Use</i>	<i>Quarter Being Updated</i>				
	Current – 1	Current – 2	Current – 3	Current – 4	Current – 5
Current				X	
Current – 1					X
Current – 2					
Current – 3					
Current – 4					
Current – 5	X				

Example of Macro 091/126 using State Default Parameters:

Macro data

<u>Quarter</u>	<u>Number of Establishments</u>	<u>M1</u>	<u>M2</u>	<u>M3</u>
4	4	135	136	101
3	4	82	59	60
2	4	63	63	63
1	3	100	105	110
Current	2	180	190	190

Current Quarter Micro data:

<u>UI/RUN</u>	<u>M1 Emp</u>	<u>M2 Emp</u>	<u>M3 Emp</u>	<u>Total Wages</u>
0000000001/00000	100	100	100	100,000
0000000002/00000	80	90	90	60,000
0000000003/00000	0	0	0	0
0000000004/00000	0	0	0	0

Prior Quarter Micro data:

<u>UI/RUN</u>	<u>M1 Emp</u>	<u>M2 Emp</u>	<u>M3 Emp</u>	<u>Total Wages</u>
0000000001/00000	90	95	90	100,000
0000000002/00000	10	10	20	60,000
0000000003/00000	0	0	0	10,000
0000000004/00000	0	0	0	0

A. Example Small Record Bypass:

- (i) $\text{Max}(135, 136, 101, 82, 59, 60) = 136$
Since $136 > 40$ (*SMALL-MACRO-REC-BYPASS*), go to step (ii).
- (ii) $\text{NumEstab}_c = 2$
 $\text{NumEstab}_p = 3$
 $\text{NumEstablMultiplier} = 0.5 \times \text{Min}(\text{NumEstab}_c, \text{NumEstab}_p) = 0.5 \times \text{Min}(2, 3) = 0.5 * 2 = 1$
Go to B (Pre-edit for Month 1).

B. Example Pre-edit (MONTH 1):

Number of Establishments $\neq 0$ for all four prior quarters
Go to C (Step 1).

TEST MONTH 1**C. Example Step 1: Minor Fluctuation Test--Absolute Difference (MONTH 1):**

MC = Month 1 = 180

MP = Prior Quarter Month 3 = 110

$\text{AME}_p = (100 + 105 + 110)/3 = 105 \geq \text{NumEstablMultiplier} \times \text{EMPL-DIFF-SPL-AME} = 1 \times 20 = 20$

$|\text{MC} - \text{MP}| = |180 - 110| = 70 > \text{NumEstablMultiplier} \times \text{HIGH-EMPL-MAX-DIFF} = 1 \times 30 = 30$

The conditions in (2) are true, so go to D (Step 2).

D. Example Step 2: Minor Fluctuation Test--Percent Change (MONTH 1):

Number of available months in four prior quarters = 12

$$|MC - MP| = |180 - 110| = 70 > HIGH-REPORTING-PCT-CHG \times MP = 0.1 \times 110 = 11$$

The conditions in (1) are true, so go to E (Step 3).

E. Example Step 3: t-test (MONTH 1):

$$\text{Max}(\text{employment in four prior quarters}) = \text{Max}(100, 105, 110, 63, 63, 63, 82, 59, 60, 135, 136, 101) = 136$$

$$\text{Min}(\text{employment in four prior quarters}) = \text{Min}(100, 105, 110, 63, 63, 63, 82, 59, 60, 135, 136, 101) = 59$$

$$\text{RANGE} = \text{maximum employment} - \text{minimum employment} = 136 - 59 = 77$$

$$n - 1 = \text{total number of months available} - 1 = 12 - 1 = 11$$

$$t\text{-value} = 2.201 \text{ when } n-1 = 11$$

$$M_TOL = t\text{-value} \times \sqrt{2} \times (\text{RANGE} / 6) = 2.201 \times \sqrt{2} \times (77/6) = 39.946$$

$$|MC - MP| = |180 - 110| = 70 > M_TOL = 39.946$$

The condition is true, so go to F (Step 4).

F. Example Step 4: Seasonality Fluctuation Test--Absolute Difference (MONTH 1):

$$AME_y = (135 + 136 + 101) / 3 > (\text{NumEstablMultiplier} \times HIGH-EMPL-MAX-DIFF) = 1 \times 20$$

$$124 > 20$$

$$|MC - MC_y| = |180 - 135| > (\text{NumEstablMultiplier} \times HIGH-EMPL-MAX-DIFF) = 1 \times 30$$

$$45 > 30$$

The conditions in (2) are true, so go to G (Step 5).

G. Example Step 5: Seasonality Fluctuation Test--Percent Change (MONTH 1):

Number of available months employment = 12

$$|MC - MC_y| = |180 - 135| > HIGH-REPORTING-PCT-CHG \times MC_y = (0.10) \times (135)$$

$$45 > 13.5$$

The conditions in (2) are true, so go to H (Step 6).

H. Example Step 6: Seasonality t-test (MONTH 1):

$$|MC - MC_y| = |180 - 135| > M_TOL \text{ (M_TOL was defined in Step 3)}$$

$$45 > 39.946$$

The condition is true, so go to I ‘determining edit level.’)

I. Example Determining Edit Level (MONTH 1):

$$|M_c - M_p| < (\text{NumEstablMultiplier} \times \text{EMPL-DIFF-SPL-AME} \times \text{EMPL-CHECK-MULTIPLIER})$$

$$|180 - 110| < (1) \times (20) \times (10)$$

$$70 < 200$$

The condition is false, so month 1 receives edit 126 in EXPO and BLS or edit 136 in WIN.
Go to J to test Month 2.

TEST MONTH 2**J. Example Pre-edit (MONTH 1):**

Number of Establishments \neq 0 for all 4 prior quarters.
Go to K (Step 1).

K. Example Step 1: Minor Fluctuation Test--Absolute Difference (MONTH 2):

$$MC = \text{Month 2} = 190$$

$$MP = \text{Month 1} = 180$$

$$AME_p = (100 + 105 + 110)/3 = 105 \geq \text{NumEstablMultiplier} \times \text{EMPL-DIFF-SPL-AME} = 1 \times 20$$

$$= 20$$

$$|MC - MP| = |190 - 110| = 80 < \text{NumEstablMultiplier} \times \text{HIGH-EMPL-MAX-DIFF} = 1 \times 30 = 30$$

The 2nd condition in (2) is false, so bypass the rest of the edit for Month 2.
Go to L to test Month 3.

TEST MONTH 3**L. Example Pre-edit (MONTH 1):**

Number of Establishments \neq 0 for all four prior quarters
Go to M (Step 1)

M. Example Step 1: Minor Fluctuation Test--Absolute Difference (MONTH 3):

MC = Month 3 = 190

MP = Month 2 = 190

$$AME_p = (100 + 105 + 110)/3 = 105 \geq \text{NumEstablMultiplier} \times \text{EMPL-DIFF-SPL-AME} = 1 \times 20 = 20$$

$$|MC - MP| = |190 - 190| = 0 < \text{NumEstablMultiplier} \times \text{HIGH-EMPL-MAX-DIFF} = 1 \times 30 = 30$$

The 2nd condition in (2) is false, so bypass the rest of the edit for Month 3.

EXPO and BLS: Since Month 1 received edit 126, the record receives edit 126.

WIN-202: Record receives edit 136.

Editing Parameters/Tolerances:

Parameter	Parameter Name	Length	EXPO PK #	WIN PK #	State Default	BLS Default
<i>EMPL-CHECK-MULTIPLIER</i>	Employment Check Multiplier	2	053	010	10	10
<i>EMPL-DIFF-SPL-AME</i>	Split Level For Employment Difference	2	010	005	20	20
<i>LOW-EMPL-MAX-DIFF</i>	Low Employment Maximum Employment Difference	2	011	006	15	15
<i>HIGH-EMPL-MAX-DIFF</i>	High Employment Maximum Employment Difference	2	012	007	40	40
<i>HIGH-REPORTING-PCT-CHG</i>	Employment Percent Change Limit For > 6 Reported Months	2	013	008	10	10
<i>REPORTING-PCT-CHG</i>	Employment Percent Change Limit For < 6 Reported Months	2	014	009	30	30
<i>SMALL-MACRO-REC-BYPASS</i>	Macro Small Record Bypass	2 (3 in BLS)	073	086	100	100
<i>NUM-ESTABL-LIMIT</i>	Macro Number of Establishments Limit	6	076	087	100	100
<i>NONZERO-EMPL-CUTOFF</i>	Macro Non-zero Employment Cutoff	6	075	088	50	50

092 — Large Wage Change Check

General Description: Edits 092 and 127 look for unusual fluctuations in Average Quarterly Wages. The largest fluctuations flag with code 092, while smaller (but still questionable) fluctuations flag with code 127. This edit is performed at both the micro and macro levels and consists of two stages: (1) the current quarter AQW is compared to the prior quarter AQW, and (2) a statistical test is used to compare the current AQW to the four prior AQWs. There are some additional tests, but these two parts comprise the core of the edit.

The record fails the edit in the following situations:

- Fails stage one, and
- Does not have sufficient data for stage two

OR

- Fails stage one, and
- Fails stage two

OR

- Fails stage one, and
- Passes stage two, and
- Fails the supplement edit

Location: Both BLS & state systems
Edit Level: 5
Priority: A

Level: Micro & Macro
Edit Type: Warning
BLS Edit Publ. Criteria: Include, if flagged

Edit Message: *AQW Change Is Significantly > Parm and Exceeds Twice the Quartile AQW Range*

Definitions

M1 = Month 1 Employment

M2 = Month 2 Employment

M3 = Month 3 Employment

TW = Total Wages

AME = (Month 1 Employment + Month 2 Employment + Month 3 Employment)/3

AQW = Total Wages ÷ AME , if AME ≠ 0
Total Wages, if AME = 0

TW-IND = Total Wage Indicator

Subscripts of c refer to the current quarter

Subscripts of cy refer to the quarter one year ago from the current quarter

Subscripts of p refer to the prior quarter

Micro Edit Conditions

Edit Conditions:

Edit if:

- $MEEIc \neq 2$
- $STATUSc \neq 2, 3, \text{ or } 9$

A. PRE-EDIT

(i) Conditions:

- $AMEc > NO-WAGE-MAX-EMPL$
- $TWc = 0$

If one or both of these conditions is false, continue to step (ii) of the 'pre-edit'.

If both conditions are true, bypass the rest of the edit. (Stop - does not fail 092 or 127. It will fail 093 or 130. See edit 093 for details.)

(ii) Conditions:

- $M1c = M2c = M3c = 0$
- $TWc > NO-EMP-MAX-WAGE$

If one or both of these conditions is false, go to B. (Continue to 'small record bypass'.)

If both conditions are true, bypass the rest of the edit. (Stop - does not fail 092 or 127. It will fail 094 or 131. See edit 094 for details.)

B. SMALL RECORD BYPASS

Conditions:

1)

- $AMEp < AME-WAGE-CUTOFF$
- $AMEc < AME-WAGE-CUTOFF$
- $TWp < TW-WAGE-CUTOFF$
- $TWc < TW-WAGE-CUTOFF$

OR

2)

- $|TW_c - TW_p| < TW\text{-CHANGE-SMALL-RECORD-BYPASS}$

If all four of the conditions in (1) are true or the condition in (2) is true, bypass the edit (stop - does not fail 092 or 127).

Otherwise, go to C. (Continue to 'checking for newly reported records.').

C. CHECKING FOR NEWLY REPORTED RECORDS

(i) Condition:

- $TW\text{-IND}_c = M, N, \text{ or } X$

If the condition is true, bypass the edit. (Stop - does not fail 092 or 127.)

If the condition is false, continue with step (ii).

(ii) Conditions:

- Each of the 4 prior quarters has
- $TW\text{-IND} = M, N, \text{ or } X$
OR
- $STATUS = 2, 3, \text{ or } 9$
- $AQW_c \geq WAGE\text{-CHG-CUTOFF} \times EMPL\text{-CHECK-MULTIPLIER}$

If both conditions are true, flag with 092 and bypass the rest of the edit.

If 1st condition is true but not the 2nd, bypass the edit. (Stop - does not fail 092 or 127.)

If 1st condition is false, go to D. (Continue with 'large record flag.')

D. LARGE RECORD FLAG

Conditions:

- $STATUS_c = 1$
- $STATUS_p = 1$
- $|TW_c - TW_p| > 2,000,000$
- $|AQW_c - AQW_p| \leq WAGE\text{-CHG-CUTOFF}$
- $|AQW_c - AQW_p| / AQW_p \geq 0.25$ (only do this condition when $AQW_p \neq 0$)

If all of the conditions are true, then flag with 092 and stop. (Bypass the rest of the edit.)

If at least one of the conditions is false, go to E. (Continue with 'stage 1.')

E. STAGE 1

Condition:

- $|AQW_c - AQW_p| > WAGE\text{-CHG-CUTOFF}$

If the condition is true, go to F. (Continue with 'stage 2.')

If the condition is not true, bypass the edit. (Stop - does not fail 092 or 127.)

F. STAGE 2

(i) Condition:

- At least one of the current or four prior quarters has
 - TW-IND = M, N, or X
- OR
- STATUS = 2, 3, or 9

If the condition in (i) is true, go to H. (Bypass the rest of stage 2 and the supplemental edit and continue to 'edit level check.')

If the condition is false, continue to (ii) of 'stage 2.'

(ii) Let

FU = 2nd highest AQW of all AQWs of the current and four prior quarters

FL = 2nd lowest AQW of all AQWs of the current and four prior quarters

This is done by eliminating the highest and lowest AQW and finding the maximum and minimum of the remaining three. It is possible to have FU equal to the highest value and FL equal to the lowest value.

Let

$$\text{WAGE RANGE} = 2 \times (\text{FU} - \text{FL})$$

If $\text{WAGE RANGE} < \text{WAGE-CHG-CUTOFF}$, then let $\text{WAGE RANGE} = \text{WAGE-CHG-CUTOFF}$

Conditions:

- $\text{AQW}_c > \text{FU} + \text{WAGE RANGE}$
- $\text{AQW}_c < \text{FL} - \text{WAGE RANGE}$

If one of the conditions in (ii) is true, go to H. (Bypass the supplemental edit and continue to 'edit level check.')

If both conditions in (ii) are false, go to G. (Continue to 'supplemental edit.')

G. SUPPLEMENTAL EDIT

Conditions:

- AQW_c is less than the AQWs of all four prior quarters
- $(\text{FL} - \text{WAGE RANGE}) < 0$
- $|\text{AQW}_c - \text{AQW}_p| > \text{SUPPL-WAGE-DIFF}$
- $\text{AME}_c > \text{SUPPL-AME}$ or $\text{AME}_p > \text{SUPPL-AME}$

If all four of these conditions are true, go to H. (Continue to the 'edit level check.')

If at least one of these conditions is false, bypass the rest of the edit. (Stop - does not fail 092 or 127.)

H. EDIT LEVEL CHECK

- $|AQW_c - AQW_p| > WAGE\text{-}CHG\text{-}CUTOFF \times WAGE\text{-}CHECK\text{-}MULTIPLIER$

If this condition is true, flag with edit 092.

If this condition is false, flag with edit 127.

EDITING UPDATES TO PREVIOUS QUARTERS

States extract or update data *up to four quarters* earlier than the current processing quarter. Updates include corrections to reported data and the replacement of estimates with reported data. However, there are limited quarters of historical data available on the database. Since all updates should be edited, even if they are four quarters back, the normal micro edits described earlier do not have enough historical data available to perform all the tests. If fewer tests were performed, a record would have fewer opportunities to pass the edits. This would cause updates to the earliest quarters to be more likely to flag. Therefore, the data that are used to edit back quarters are not restricted to data from quarters prior to the quarter being edited, but may also include quarters that are more recent than the quarter being reviewed.

Quarters to Use for Stage 2 and Supplemental Edit

For the Stage 2 test and the supplemental edit, the editing of updates to previous quarters involves using data from historical quarters. Current and four additional quarters worth of data must be used to perform the test. The following table shows which quarters to use when performing the Stage 2 test and the Supplemental edit.

For example, if the current quarter was 2018/1 and an update was made to total wages for 2017/3, the Stage 2 test and Supplemental Edit would use 2018/1, 2017/4, 2017/3, 2017/2, and 2017/1 to edit the updated record.

<i>Quarters to Use</i>	<i>Quarter Being Updated</i>				
	Current – 1	Current – 2	Current – 3	Current – 4	Current – 5
Current		X	X	X	
Current – 1	X	X	X	X	X
Current – 2	X	X	X	X	X
Current – 3	X	X	X	X	X
Current – 4	X	X	X	X	X
Current – 5	X				X

Editing Parameters/Tolerances:

Parameter	Parameter Name	Length	EXPO PK #	WIN PK #	State Default	BLS Default
<i>AME-WAGE-CUTOFF</i>	AME Wage Cutoff	6	071	091	25	25
<i>TW-WAGE-CUTOFF</i>	TW Cutoff	6	072	092	100,000	100,000
<i>TW-CHANGE-SMALL-RECORD-BYPASS</i>	TW Change Small Record Bypass	6	077	N/A	50,000	50,000
<i>EMPL-CHECK-MULTIPLIER</i>	Employment Check Multiplier	2	053	010	10	10
<i>NO-WAGE-MAX-EMPL</i>	No Total Wages With AME Cutoff	2	008	011	15	15
<i>NO-EMPL-MAX-WAGE</i>	No Employment With TW Cutoff	6	007	015	100,000	100,000
<i>WAGE-CHG-CUTOFF</i>	Total Wage Change Parm	6	019	012	15,000	15,000
<i>WAGE-CHECK-MULTIPLIER</i>	Total Wage Check Multiplier	2	059	013	10	10
<i>SUPPL-AME</i>	Supplemental Edit AME	6	057	071	75	75
<i>SUPPL-WAGE-DIFF</i>	Supplemental Edit AQW Difference	6	058	072	10,000	10,000

Macro Edit Conditions

Edit Conditions:**A. PRE-EDIT**

(i) Conditions:

- Each of the four prior quarters has Number of Establishments = 0
- Each of the two prior quarters has Number of Establishments = 0 and $TW_c < NONZERO-WAGE-CUTOFF$

If either condition is true, then bypass the rest of the edit. (Stop - does not fail 092 or 127.)

If both conditions are false, continue with step (ii) of 'pre-edit.'

(ii) Conditions:

- $AME_c > NO-WAGE-MAX-EMPL$
- $TW_c = 0$

If one or both of these conditions is false, continue with step (iii) of the Pre-edit.

If both conditions are true, bypass rest of the edit. (Stop - does not fail 092 or 127. It should fail 093 or 130. See Edit 093 for details.)

(iii) Conditions:

- $M1c = M2c = M3c = 0$
- $TWc > NO-EMP-MAX-WAGE$

If one or both of these conditions is false, go to B. (Continue to 'small record bypass.')

If both conditions are true, bypass the rest of the edit. (Stop - does not fail 092 or 127. It should fail 094 or 131. See Edit 094 for details.)

B. SMALL RECORD BYPASS

Conditions:

- $AMEp < MACRO-AME-WAGE-CUTOFF$
- $AMEc < MACRO-AME-WAGE-CUTOFF$
- $TWp < MACRO-TW-WAGE-CUTOFF$
- $TWc < MACRO-TW-WAGE-CUTOFF$

If all four of the conditions are true, the system will bypass the edit. (Stop - does not fail 092 or 127.)

If at least one of the four conditions are false, go to C. (Continue with 'large record flag.')

C. LARGE RECORD FLAG

Conditions:

(1)

- $AMEc > 1000$
- $|AQWc - AQWp| > 5000$

OR

(2)

- $AMEc > 10000$
- $|AQWc - AQWp| > 1000$

OR

(3)

- $|AQWc - AQWp| \leq WAGE-CHG-CUTOFF$
- $|TWc - TWp| > 1,000,000$
- $|AQWc - AQWp| \div \text{MAX}(AQWc, AQWp) > 0.25$ (if $\text{MAX}(AQWc, AQWp) = 0$ then do not use this condition)
- $|TWc - TWy| > 1,000,000$
- $|AQWc - AQWy| \div \text{MAX}(AQWc, AQWy) > 0.25$ (if $\text{MAX}(AQWc, AQWy) = 0$ then do not use this condition)

If all the conditions in (1) are true or all conditions in (2) are true or all conditions that can be performed in (3) are true, then flag with 092 and bypass the rest of the edit.

Otherwise, if all three sets of conditions contain at least one false statement, go to D. (Continue with 'stage1.')

D. STAGE 1

Condition:

- $|AQW_c - AQW_p| > WAGE-CHG-CUTOFF$

If the condition is true, go to E. (Continue with 'stage 2.')

If the condition is false, bypass the rest of the edit. (Stop - does not fail 092 or 127.)

E. STAGE 2

(i) Condition:

- At least one of the current or four prior quarters has Number of Establishments = 0

If the condition is true, go to F. (Bypass rest of 'stage 2' and 'supplemental edit' and go to 'edit level check.')

If the condition is false, continue with step (ii) of 'stage 2.'

(ii) Let

FU = 2nd highest AQW of all AQWs of the current and four prior quarters

FL = 2nd lowest AQW of all AQWs of the current and four prior quarters

The system does this by eliminating the highest and lowest AQW and finding the maximum and minimum of the remaining three. It is possible to have FU equal to the highest value and FL equal to the lowest value.

Let

$$WAGE\ RANGE = 2 \times (FU - FL)$$

If $WAGE\ RANGE < WAGE-CHG-CUTOFF$, then let $WAGE\ RANGE = WAGE-CHG-CUTOFF$

Conditions:

- $AQW_c > FU + WAGE\ RANGE$
- $AQW_c < FL - WAGE\ RANGE$

If one of the conditions is true, go to G. (Bypass the 'supplemental edit' and continue to the 'edit level check.')

If both conditions are false, go to F. (Continue to the 'supplemental edit'.')

F. SUPPLEMENTAL EDIT

Conditions:

- AQWC IS LESS THAN THE AQWS OF THE 4 PRIOR QUARTERS
- $(FL - WAGE\ RANGE) < 0$
- $|AQWC - AQWP| > SUPPL-WAGE-DIFF$
- $AMEC > SUPPL-AME$ OR $AMEP > SUPPL-AME$

If all four of the conditions are true, go to G. (Continue to the 'edit level check.')

If at least one of the conditions is false, bypass the rest of the edit. (Stop - does not fail 092 or 127.)

G. EDIT LEVEL CHECK

Condition:

- $|AQWC - AQWP| > WAGE-CHG-CUTOFF \times WAGE-CHECK-MULTIPLIER$

If this condition is true, flag with edit 092.

If this condition is false, flag with edit 127.

CODE CHANGE INTEGRATION

Macro editing of updates to historical data becomes complicated due to the Code Change Integration in the first quarter of each calendar year. Therefore, whenever the updated quarter is the first quarter, the data are temporarily adjusted to eliminate the effect of the code changes. This adjustment is based on the net change for the cell from the Summary of Differences file, described in Section 11.6. (The only exception to this occurs when there are two first quarters on the file and the update is to the older first quarter. Whenever this occurs, there is no CCS or Summary of Differences file for that quarter, so the data cannot be adjusted.) Non-adjusted data are maintained on the files.

EDITING UPDATES TO PREVIOUS QUARTERS

States extract or update data *up to four quarters* earlier than the current processing quarter. Updates include corrections to reported data and the replacement of estimates with reported data. However, there are limited quarters of historical data available on the database. Since all updates should be edited, even if they are four quarters back, the normal macro edits described earlier do not have enough historical data available to perform all the tests. If fewer tests were performed, a record would have fewer opportunities to pass the edits. This would cause updates to the earliest quarters to be more likely to flag. Therefore, the data that are used to edit back quarters are not restricted to data from quarters prior to the quarter being edited, but may also include quarters that are more recent than the quarter being reviewed.

Quarters to Use for Stage 2 test and Supplemental Edit

For the Stage 2 test and the supplemental edit, the editing of updates to previous quarters involves using data from historical quarters. Current and four additional quarters worth of data must be used to perform the test. The following table shows which quarters to use when performing the Stage 2 test and the Supplemental edit.

For example, if the current quarter was 2018/1 and an update was made to total wages for 2017/3, the Stage 2 test and Supplemental Edit would use 2018/1, 2017/4, 2017/3, 2017/2, and 2017/1 to edit the updated record.

<i>Quarters to Use</i>	<i>Quarter Being Updated</i>				
	Current – 1	Current – 2	Current – 3	Current – 4	Current – 5
Current		X	X	X	
Current – 1	X	X	X	X	X
Current – 2	X	X	X	X	X
Current – 3	X	X	X	X	X
Current – 4	X	X	X	X	X
Current – 5	X				X

Editing Parameters/Tolerances:

Parameter	Parameter Name	Length	EXPO PK #	WIN PK #	State Default	BLS Default
<i>EMPL-CHECK-MULTIPLIER</i>	Employment Check Multiplier	2	053	010	10	10
<i>NO-WAGE-MAX-EMPL</i>	No Total Wages With AME Cutoff	2	008	011	15	15
<i>NO-EMPL-MAX-WAGE</i>	No Employment With TW Cutoff	6	007	015	100,000	100,000
<i>WAGE-CHG-CUTOFF</i>	Total Wage Change Parm	6	019	012	15,000	15,000
<i>WAGE-CHECK-MULTIPLIER</i>	Total Wage Check Multiplier	2	059	013	10	10
<i>SUPPL-AME</i>	Supplemental Edit AME	6	057	071	75	75
SUPPL-WAGE-DIFF	Supplemental Edit AQW Difference	6	058	072	10,000	10,000
MACRO-AME-WAGE-CUTOFF	Macro AME Wage Cutoff	6	073	093	100	100
TW-WAGE-CUTOFF	Macro TW Wage Cutoff	6	074	089	500,000	500,000
<i>NONZERO-WAGE-CUTOFF</i>	Macro Nonzero Wage Cutoff	6 (9 at BLS)	N/A	090	2,000,000	2,000,000

093 — Employment Without Wages Check

General Description: Edits 093 and 130 look for situations in which employment is significant but there are no wages. These edits help ensure that wage data are either reported or imputed. When a record flagged for these edit conditions has large employment (larger than a parameter), edit code 093 is assigned. Smaller (but still significant) levels of employment receive edit code 130.

This edit flags when partial imputations are made (where the system was able to generate employment imputations but not the wage imputation) or when a predecessor/successor situation occurs and the employment is transferred to only one owner while the employment is reported by each employer.

Location: Both BLS & state systems

Edit Level: 5

Priority: A

Level: Micro & Macro

Edit Type: Warning

BLS Edit Publ. Criteria: Include, if flagged

Edit Message: *Average Employment Is Significantly > parm, but Total Wages = \$0*

Edit Conditions:

MICRO

Flag if the following conditions are true:

- STATUS \neq 2, 3 or 9
- AME > NO-WAGE-MAX-EMPL
- TW = 0

Determining Edit Level:

When flagged, code as 093 if $AME > NO-WAGE-MAX-EMPL \times NO-WAGE-MAX-EMPL-MULTIPLIER$
Else code as 130.

MACRO

Flag if the following conditions are true:

- AME > NO-WAGE-MAX-EMPL
- TW = 0

Determining Edit Level:

When flagged, code as 093 if $AME > NO-WAGE-MAX-EMPL \times NO-WAGE-MAX-EMPL-MULTIPLIER$
Else code as 130.

Editing Parameters/Tolerances:

Parameter	Parameter Name	Length	EXPO PK #	WIN PK #	State Default	BLS Default
<i>NO-WAGE-MAX-EMPL</i>	No Total Wages With AME Cutoff	2	008	011	15	15
<i>NO-WAGE-MAX-EMPL- MULTIPLIER</i>	No Wages But AME Multiplier	2	053	014	10	10

094 — Wages Without Employment Check

General Description: Edits 094 and 131 look for situations in which employment is zero but wages are significant. These edits help ensure that employment data are either reported or imputed. When a record flagged for these edit conditions has large wages, edit code 094 is assigned. When a flagged record has a lower wage level (that is still significant), the edit code 131 is assigned.

This situation occurs more often than employment without wages (edits 093 and 130). There are more situations where wages are either reported or successfully imputed without reported or imputed employment than where wages are missing and employment is present. Additionally, since wages represent those wages earned during the entire quarter and employment represents the employment reported or imputed for the reporting periods which include the 12th of each month, it is possible that wages are only paid for a period of time for which the employment were not reported.

Location: Both BLS & state systems
Edit Level: 5
Priority: A

Level: Micro & Macro
Edit Type: Warning
BLS Edit Publ. Criteria: Include, if flagged

Edit Message: *Average Employment = 0, but Total Wages Is Significantly > parm*

Edit Conditions:**MICRO**

Flag if the following conditions are true:

- STATUS ≠ 2, 3, or 9
- M1 = M2 = M3 = 0
- TW > NO-EMPL-MAX-WAGE

Determining Edit Level:

When flagged, code as 094 if $TW > NO-EMPL-MAX-WAGE \times NO-EMPL-MAX-WAGE-MULTIPLIER$
Else code as 131.

MACRO

Flag if the following conditions are true:

- $M1 = M2 = M3 = 0$
- $TW > NO-EMPL-MAX-WAGE$

Determining Edit Level:

When flagged, code as 094 if $TW > NO-EMPL-MAX-WAGE \times NO-EMPL-MAX-WAGE-MULTIPLIER$
Else code as 131.

Editing Parameters/Tolerances:

Parameter	Parameter Name	Length	EXPO PK #	WIN PK #	State Default	BLS Default
<i>NO-EMPL-MAX-WAGE</i>	No Employment With TQW Cutoff	6	007	015	100,000	100,000
<i>NO-EMPL-MAX- WAGE-MULTIPLIER</i>	No Employment with TQW Cutoff Multiplier	2	059	016	3	10

095 — Wages/Employment Sum Check

General Description: Edits 095 and 132 check for entries in total wages that are equal to the sum of the three months employment. This edit identifies situations where monthly wages appear to have been reported in lieu of monthly employment. If the edit conditions apply and employment is large, edit code 095 is assigned. If the flagged record has smaller employment (but is still significant), edit 132 is assigned.

Location: Both BLS & state systems

Edit Level: 5

Priority: A

Level: Micro

Edit Type: Warning

BLS Edit Publ. Criteria: Include, if flagged

Edit Message: *Total Wages = Sum of Employment +/- parm If AME Is Large*

Edit Conditions:

Flag if the following conditions are true:

- $STATUS \neq 2, 3, \text{ or } 9$
- $AME > EMPL-EQ-WAGE-AME$
- $|TW - (M1 + M2 + M3)| < EMPL-EQ-WAGE-TOL$

Determining Edit Level:

When flagged, code as 095 if $AME > EMPL-EQ-WAGE-AME \times EMPL-EQ-WAGE-MULTIPLIER$
Else code as 132

Editing Parameters/Tolerances:

Parameter	Parameter Name	Length	EXPO PK #	WIN PK #	State Default	BLS Default
<i>EMPL-EQ-WAGE-TOL</i>	Employment Equals Total Wages Tolerance	2	041	017	5	5
<i>EMPL-EQ-WAGE-AME</i>	Employment Equals Total Wages AME Cutoff	6	042	018	100	100
<i>EMPL-EQ-WAGE-MULTIPLIER</i>	Employment Equals Total Wages Multiplier	2	053	019	10	10

096 — Large New Record Check

General Description: Edits 096 and 139 are designed to find new employers with unusually high initial employment. Such a condition generally suggests that a predecessor/successor relationship should be reported since most new employers do not start off with a large number of employees the first month. If a predecessor account is identified for the new establishment, these edits are bypassed. New establishments that do not have the high employment level of the Large New Employment parameter can still fail the less severe edit 139 exception, if the lower threshold of the New Employment parameter is reached. Again, those accounts with an assigned predecessor will not be flagged here, because the high employment is assumed to have been brought across from the previous account.

If this edit flag is assigned, check wage records to determine if a large number of the employees of this new record were previously reported by the same terminated or downsized account. This may help identify the record's predecessor.

If the flagged large record is the result of a multi collapse, work with the employer to resume the multi breakouts, arrange for periodic breakout reporting, or notify the EDI Center if the record is part of a large multi- state reporter.

If no other sources are available, contact the employer or its representative to obtain additional information about such a large new account.

Location: Both BLS & state systems

Edit Level: 5

Priority: A

Level: Micro

Edit Type: Warning

BLS Edit Publ. Criteria: Include, if flagged

Edit Message: *Unusually Large New Record on File*

Edit Conditions:

Flag if all conditions are true:

- $STATUS_c \neq 2, 3, \text{ or } 9$
 - Each of the 6 earlier quarters has either
M1-IND, M2-IND, and M3-IND = M, N, or X
- OR
- $STATUS = 2, 3, \text{ or } 9$.
(In other words, the earlier quarters may be a combination of M, N, or X employment indicators, or $STATUS = 2, 3 \text{ or } 9$)
 - PRED UI# is blank
 - PRED RUN is blank
 - The first month of non-zero employment in the current quarter $\geq NEW-EMPL$

Determining Edit Level:

When flagged, if first month of nonzero employment in current quarter $\geq LARGE-NEW-EMPL$, then code as 096.

Else if $NEW-EMPL \leq$ first month of nonzero employment in current quarter $\leq LARGE-NEW-EMPL$, then code as 139.

Editing Parameters/Tolerances:

Parameter	Parameter Name	Length	EXPO PK #	WIN PK #	State Default	BLS Default
<i>NEW-EMPL</i>	New Employer	6	061	075	50	50
<i>LARGE-NEW-EMPL</i>	Large New Employer	6	060	073	250	250

System Action: Edit bypassed if flagged for 085.

097 — Large Discontinued Record Check

General Description: Edit 097 is essentially the reverse of edit 096. Instead of looking for a new high-employment unit, this edit flags employers that have gone out of business with a high final employment. This combination most often carries a successor relationship, so that the large number of employees can be carried over to the new employer. Because of this, records with a successor account are exempt from this edit. An unusual aspect of this edit is that it requires the account to be currently inactive, the opposite of most other edits. A smaller scale version of this edit is edit 140, described later in this appendix. Edit 140 uses a lower-limit cutoff value (the Discontinued Employment parameter) for accounts that terminate without a successor and with substantial employment, though not quite up to the scale of the parm used in edit 097.

It is rare that accounts or units terminate with such large employment levels without transferring their employees to a successor. If this record does not have a successor, check wage records or contact the employer to find out if the data should truly drop off in this manner. A large unit may also be terminated if the data from the unit is distributed among other units as the result of a multi breakout.

Location: Both BLS & state systems
 Edit Level: 5
 Priority: A

Level: Micro
 Edit Type: Warning
 BLS Edit Publ. Criteria: Include, if flagged

Edit Message: *Unusually Large Discontinued Record Inactivated*

Edit Conditions:

Flag if all conditions are true:

- STATUS_p = 1
- STATUS_c = 2 or 3
- SUCC UI# is blank
- SUCC RUN is blank
- $M3_p \geq DISC-EMPL$

Determining Edit Level:

When flagged, if $M3_p \geq LARGE-DISC-EMPL$, then code as 097

Else if $DISC-EMPL \leq M3_p \leq LARGE-DISC-EMPL$, then code as 140

Edit Parameters/Tolerances:

Parameter	Parameter Name	Length	EXPO PK #	WIN PK #	State Default	BLS Default
<i>DISC-EMPL</i>	Discontinued Employer	6	061	076	50	50
<i>LARGE-DISC-EMPL</i>	Large Discontinued Employer	6	060	074	250	250

System Action: Edit bypassed if flagged for 086.

099 — Large Imputation Check

General Description: When attempting to generate imputations for delinquent accounts, the state processing systems either successfully impute (where the system was able to derive a value for the employment and/or wage field) or fail to impute (where the record had already been imputed for two or more quarters or there were not sufficient historical data or information to derive an imputation). It is important to review large records that are imputed to ensure that it is still in business, was not sold, and was imputed at a level similar to what should have been reported.

Most states review larger failed imputations and either contact the employer for actual data, make a hand imputation, or determine if the business has been sold or is now inactive. Many states do not review successful imputations but rely on the edits to fail questionable data. Since a typical imputation is based on the record’s history and most of the edits compare the record to its history, successful imputations rarely fail employment and wage micro edits. In some cases, if the record is large and was sold and was reported with a unit that was coded in the same industry/area/ownership cell, the macro data may fail.

Location: Both BLS & state systems	Level: Micro
Edit Level: 5	Edit Type: Warning
Priority: A	BLS Edit Publ. Criteria: Include, if flagged

Edit Message: *Questionable Large Imputation*

Edit Conditions:

Flag if all conditions are true:

- OWN = 5
- STATUS_c ≠ 2, 3, or 9
- MEEI_c ≠ 2
- [(M1_c ≥ LARGE-IMP-EMP and M1-IND_c = E, K, M, or N)
 OR
 (M2_c ≥ LARGE-IMP-EMP and M2-IND_c = E, K, M, or N)
 OR
 (M3_c ≥ LARGE-IMP-EMP and M3-IND_c = E, K, M, or N)]
- [(TW-IND_c ≠ blank, R, C, L)] OR [(TW_c ≤ LARGE-IMP-WAGE)]

Editing Parameters/Tolerances:

Parameter	Parameter Name	Length	EXPO PK #	WIN PK #	State Default	BLS Default
LARGE-IMP-EMP	Large Imputation Employment	6	084	102	100	100
LARGE-IMP-WAGE	Large Imputation Wages	6	085	103	10,000	10,000

Level 6 Edit Descriptions – Warning Edits

Edits in this level identify fluctuations in the economic data (on both micro and macro records) that are smaller than at Level 5, but still significant. Level 6 also includes most other W (Warning) edits that flag questionable data. While the flagged data may sometimes be accurate, they are sufficiently unusual that data users would look for an explanation. Records flagged by these edits should be reviewed and corrected (where necessary) or explained with an appropriate comment code.

101 — (Mailing/Other) Address Type (MOA TYPE) Code Check

General Description: The Address Type is used to characterize the type of address in the Mailing/Other (M/O) address block: physical location address, mailing address of the reporting unit, a central office, or type unknown. If the M/O address block is blank, the Address Type should also be blank. If the M/O address block is present (indicated by the presence of an M/O state abbreviation), then the Address Type cannot be blank and must contain a valid code.

Location: Both BLS & state systems

Edit Level: 6

Priority: C

Level: Micro

Edit Type: Warning

BLS Edit Publ. Criteria: Include, if flagged

Edit Message: *Unusable Address Type Code*

Edit Conditions:

Flag if all of the following conditions are met:

- STATUS ≠ 2, 3, or 9, and
- MOA STATE is not blank, and
- MOA TYPE is blank or MOA TYPE ≠ 1, 2, 3, or 9.

Note: The system will not list the record for this flagged condition if there is at least one usable address.

System Action:

In the Sate Systems, if all of the following conditions are met:

- STATUS ≠ 2, 3, or 9, and
- MOA STATE is blank, and
- MOA TYPE is not blank.

Then, set MOA TYPE to blank.

In the BLS system, if the M/O address fields are blank but the MOA Address Type is not, the system bypasses the edit.

102 — Blank Physical Location City Check

General Description: The Blank Physical Location City edit checks for a blank City field in the PLA block. The City field should not be blank unless the entire address block is blank. If the Physical Location City is not blank, edit the other physical location address fields to ensure it is a usable address block.

Location: Both BLS & state systems	Level: Micro
Edit Level: 6	Edit Type: Warning
Priority: C	BLS Edit Publ. Criteria: Include, if flagged

Edit Message: *Blank Physical Location City; Other PLA Fields Present*

Edit Conditions:

Flag if all of the following conditions occur:

- STATUS ≠ 2, 3, or 9, and
- OWN > 1 and
- PLA CITY is blank and
- At least one other PLA field is not blank.

Note: The system will not list the record for this flagged condition if there is at least one usable address.

103 — Physical Location State Abbreviation Check

General Description: A standard two-letter postal state abbreviation should be used in this field. The PLA State Abbreviation edit ensures that the PLA address, if present, contains a valid state abbreviation. For military post offices, the field may contain “AE”, “AA,” or “AP,” while Canadian addresses may use either “CN” or “ZZ.” Foreign addresses outside Canada may use “ZZ.”

Location: Both BLS & state systems	Level: Micro
Edit Level: 6	Edit Type: Warning
Priority: C	BLS Edit Publ. Criteria: Include, if flagged

Edit Message: *Unusable Physical Location State Abbreviation*

Edit Conditions:

Flag if all of the following conditions are met:

- STATUS ≠ 2, 3, or 9, and
- OWN > 1 and
- PLA STATE ABBREVIATION is blank and
- At least one other PLA field is not blank.

Flag if all of the following conditions are met:

- STATUS \neq 2, 3, or 9, and
- OWN > 1 and
- PLA STATE ABBREVIATION \neq AL, AK, AZ, AR, CA, CO, CT, DE, DC, FL, GA, HI, ID, IL, IN, IA, KS, KY, LA, ME, MD, MA, MI, MN, MS, MO, MT, NE, NV, NH, NJ, NM, NY, NC, ND, OH, OK, OR, PA, PR, RI, SC, SD, TN, TX, UT, VT, VA, VI, WA, WV, WI, WY, AS, GU, AE, AA, AP, CN, or ZZ.

Note: The system will not list the record for this flagged condition if there is at least one usable address.

104 — Physical Location ZIP Code Format Check and Physical Location ZIP Code Extension Format Check

General Description: The PLA ZIP Code Format edit ensures that a proper ZIP Code is used in the Physical Location address. The ZIP Code is a 5-digit alphanumeric field. For U.S. addresses, this is the numeric code used by the Post Office for the specified address. For Canadian addresses, this field should contain the first five digits of the six-digit alphanumeric Canadian ZIP Code, while the Physical Location ZIP Code Extension field should contain the sixth digit followed by three blanks. The field is not edited for foreign addresses (designated by state abbreviation "ZZ").

This edit also ensures that the ZIP Code ZIP Extension field is properly used in the Physical Location address. The ZIP Code Extension is a four-digit alphanumeric field. For U.S. addresses that have a ZIP Code Extension, the field should be strictly numeric. For Canadian addresses, the ZIP Code Extension begins with the last digit of the six-position alphanumeric Canadian ZIP Code; this position is numeric and is followed by three blanks. The field is not edited for foreign addresses (designated by state abbreviation "ZZ").

Edit code 104 is used for both the Physical Location ZIP Code Format Check and the Physical Location ZIP Code Extension Format Check. The same edit message is also used for both parts of the edit.

Location: Both BLS & state systems

Level: Micro

Edit Level: 6

Edit Type: Warning

Priority: C

BLS Edit Publ. Criteria: Include, if flagged

Edit Message: *Unusable Physical Location ZIP Code Format*

Edit Conditions:

Bypass if any of the following conditions occur:

- STATUS \neq 2, 3, or 9, or
- OWN = 1 or
- CNTY = 996 or 998, or
- PLA STATE ABBREVIATION = AA, AE, AP, or ZZ, or
- PLA ZIP is blank and all other P/L address fields are blank.

Flag if all of the following conditions occur:

- (PLA STATE ABBREVIATION = AL, AK, AZ, AR, CA, CO, CT, DE, DC, FL, GA, HI, ID, IL, IN, IA, KS, KY, LA, ME, MD, MA, MI, MN, MS, MO, MT, NE, NV, NH, NJ, NM, NY, NC, ND, OH, OK, OR, PA, PR, RI, SC, SD, TN, TX, UT, VT, VA, VI, WA, WV, WI, WY, AS, or GU), and
- (PLA ZIP nonnumeric , 00000 or 99999) or (PLA ZIP EXTENSION is nonnumeric but not blank or 9999), and
- $AME_C > ZIP-CODE-AME$.

Flag if all of the following conditions occur:

- PLA STATE ABBREVIATION = CN, and
- (PLA ZIP is numeric or blank) or (PLA ZIP EXTENSION \neq a numeric followed by 3 blanks and), and
- $AME_C > ZIP-CODE-AME$.

Note: The system will not list the record for this flagged condition if there is at least one usable address.

System Action: If the ZIP Code Extension is all zeros, the system will blank fill.

Editing Parameters/Tolerances:

Parameter	Parameter Name	Length	EXPO PK #	WIN PK #	State Default	BLS Default
<i>ZIP-CODE-AME</i>	ZIP Code AME Cutoff	6	005	020	250	250

105 — Telephone Number Check

General Description: This edit checks for a usable telephone number for the UI account. The telephone number is used to contact the employer regarding reporting problems or for sampling purposes. The edit is not performed for multi subunits, since the employer should be contacted using the phone number on the master record.

Location: Both BLS & state systems

Edit Level: 6

Priority: C

Level: Micro

Edit Type: Warning

BLS Edit Publ. Criteria: Include, if flagged

Edit Message: *Unusable Telephone Format*

Edit Conditions:

Bypass if any of the following conditions occur:

- STATUS = 2, 3, or 9, or
- OWN = 1 or
- MEEI = 3 or 5, or
- TELEPHONE NUMBER is blank.

Flag if $AME_c > PHONE-AME$ and any of the following conditions occur:

- TELEPHONE NUMBER = (any area code) + 555-1212, or
- TELEPHONE NUMBER = "000" in positions 4-6, or
- TELEPHONE NUMBER positions 1-3 or 7-10 are non-numeric but not blank.

Editing Parameters/Tolerances:

Parameter	Parameter Name	Length	EXPO PK #	WIN PK #	State Default	BLS Default
<i>PHONE-AME</i>	Telephone AME Cutoff	6	005	021	999,999	999,999

Since address and telephone information is used by numerous data users, states are encouraged to leave the default parameter at an amount no higher than 99. If the state has significant address problems, then they should temporarily increase it to an amount no higher than 250.

State System Action: The state system will blank fill the field if

- The Telephone number field is all zeros or
- The last 7 digits of the field are zero or
- $AME_c > PHONE-AME$ and Telephone = (any area code)+555-1212 or
- $AME_c > PHONE-AME$ and Telephone = "000" in positions 4-6 or
- $AME_c > PHONE-AME$ and Telephone is non numeric (but not blank) in positions 1-3 or positions 7-10.

106 — UI Address City Check

General Description: This edit checks for a non-blank City field in the UI address block. The City field should not be blank unless the entire address block is blank. If the UI Address City is not blank, edit the other UI address fields to ensure it is a usable address block.

Location: Both BLS & state systems

Level: Micro

Edit Level: 6

Edit Type: Warning

Priority: C

BLS Edit Publ. Criteria: Include, if flagged

Edit Message: *Blank UI City; Other UI Address Fields Present*

Edit Conditions:

Flag if all of the following conditions occur:

- STATUS \neq 2, 3, or 9, and
- OWN > 1 and
- UI ADDRESS CITY is blank and
- At least one other UI ADDRESS field is not blank.

Note: The system will not list the record for this flagged condition if there is at least one usable address.

107 — UI State Abbreviation Check

General Description: This edit ensures that a valid state abbreviation is in the UI Address, if a UI Address is present. The standard two-letter Post Office state abbreviation is used in this field. For military post offices, the field may contain "AE", "AA," or "AP," while Canadian addresses may use either "CN" or "ZZ." Foreign addresses outside Canada should use "ZZ."

Location: Both BLS & state systems

Level: Micro

Edit Level: 6

Edit Type: Warning

Priority: C

BLS Edit Publ. Criteria: Include, if flagged

Edit Message: *Unusable UI State Abbreviation*

Edit Conditions:

Flag if all of the following conditions occur:

- STATUS ≠ 2, 3, or 9, and
- OWN > 1 and
- UI STATE ABBREVIATION is blank and
- At least one other UI ADDRESS field is not blank.

Flag if all of the following conditions occur:

- STATUS ≠ 2, 3, or 9, and
- OWN > 1 and
- UI ADDRESS STATE ABBREVIATION ≠ AL, AK, AZ, AR, CA, CO, CT, DE, DC, FL, GA, HI, ID, IL, IN, IA, KS, KY, LA, ME, MD, MA, MI, MN, MS, MO, MT, NE, NV, NH, NJ, NM, NY, NC, ND, OH, OK, OR, PA, PR, RI, SC, SD, TN, TX, UT, VT, VA, VI, WA, WV, WI, WY, AS, GU, AE, AA, AP, CN, or ZZ.

Note: The system will not list the record for this flagged condition if there is at least one usable address.

108 — UI Address ZIP Code Format Check and UI Address ZIP Code Extension Format Check

General Description: This edit helps ensure the proper use of the ZIP Code in the UI address. The ZIP Code is a five-digit alphanumeric field. United States (US) ZIP Codes are always numeric. For Canadian addresses, this field is used for the first five positions of a Canadian ZIP Code, while the UI ZIP Extension field should contain the final position of the Canadian ZIP Code. The system edits Canadian ZIP codes for proper alphanumeric format when the UI State Abbreviation field contains "CN" (for Canada). Other Foreign ZIP codes are not edited when the UI State Abbreviation is "ZZ." Guam, American Samoa, APO, and FPO ZIP codes are five-digit numeric.

This edit also ensures that the ZIP Code Extension field is properly used in the UI address. The ZIP Code Extension is a four-digit alphanumeric field. For U.S. addresses that have a ZIP Code

Extension, the field should be strictly numeric. For Canadian addresses, the ZIP Code Extension begins with the last digit of the six-position alphanumeric Canadian ZIP Code; this position is numeric and is followed by three blanks. The field is not edited for foreign addresses (designated by state abbreviation "ZZ").

Edit code 108 is used for both the UI ZIP Code Format Check and the UI ZIP Code Extension Format Check.

Location: Both BLS & state systems	Level: Micro
Edit Level: 6	Edit Type: Warning
Priority: C	BLS Edit Publ. Criteria: Include, if flagged

Edit Message: *Unusable UI Zip Code Format*

Edit Conditions:

Bypass if any of the following conditions are met:

- STATUS = 2, 3, or 9, or
- OWN = 1 or
- CNTY = 996 or 998, or
- UI ADDRESS STATE ABBREVIATION = AA, AE, AP, or ZZ, or
- UI ADDRESS ZIP CODE is blank and all other UI address fields are blank.

Flag if all of the following conditions occur:

- UI ADDRESS STATE ABBREVIATION = AL, AK, AZ, AR, CA, CO, CT, DE, DC, FL, GA, HI, ID, IL, IN, IA, KS, KY, LA, ME, MD, MA, MI, MN, MS, MO, MT, NE, NV, NH, NJ, NM, NY, NC, ND, OH, OK, OR, PA, PR, RI, SC, SD, TN, TX, UT, VT, VA, VI, WA, WV, WI, WY, AS, or GU, and
- (UI ADDRESS ZIP CODE is nonnumeric, 00000 or 99999) or (UI ZIP EXTENSION is nonnumeric or 9999), and
- $AME_C > ZIP-CODE-AME$.

Flag if all of the following conditions are met:

- UI STATE ABBREVIATION = CN and
- (UI ADDRESS ZIP CODE) is numeric or blank, or (UI ZIP EXTENSION \neq a numeric followed by 3 blanks), and
- $AME_C > ZIP-CODE-AME$.

Editing Parameters/Tolerances:

Parameter	Parameter Name	Length	EXPO PK #	WIN PK #	State Default	BLS Default
<i>ZIP-CODE-AME</i>	ZIP Code AME Cutoff	6	005	020	250	250

Note: The system will not list the record for this flagged condition if there is at least one usable address.

System Action: If the ZIP Code Extension is all zeros, the system will blank fill the field.

109 — Blank Mailing/Other City Check

General Description: This edit checks for a non-blank City field in the M/O address block. The City field should not be blank unless the entire address block is blank. If the Mailing/Other City is not blank, edit the other mailing/other address fields to ensure it is a usable address block.

Location: Both BLS & state systems

Level: Micro

Edit Level: 6

Edit Type: Warning

Priority: C

BLS Edit Publ. Criteria: Include, if flagged

Edit Message: *Blank Mailing/Other City; Other M/O Address Fields Present*

Edit Conditions:

Flag if all of the following conditions occur:

- STATUS \neq 2, 3, or 9, and
- OWN > 1 and
- MOA CITY is blank and
- At least one other MOA field (other than MOA ADDRESS TYPE) is not blank.

Note: The system will not list the record for this flagged condition if there is at least one usable address.

110 — Mailing/Other State Abbreviation Check

General Description: This edit ensures that a valid state abbreviation is in the Mailing/Other address block. The standard two-letter Post Office state abbreviation is used in this field. For military post offices, the field may contain "AE", "AA," or "AP," while Canadian addresses may use either "CN" or "ZZ." Foreign addresses outside Canada should use "ZZ."

Location: Both BLS & state systems	Level: Micro
Edit Level: 6	Edit Type: Warning
Priority: C	BLS Edit Publ. Criteria: Include, if flagged

Edit Message: *Unusable Mailing/Other State Abbreviation*

Edit Conditions:

Flag if all of the following conditions occur:

- STATUS ≠ 2, 3, or 9, and
- OWN > 1 and
- MOA STATE ABBREVIATION is blank and
- At least one other MOA field is not blank. (A non-blank MOA ADDRESS TYPE should not be considered as part of the MAILING/OTHER address for this edit condition.)

Flag if all of the following conditions occur:

- STATUS ≠ 2, 3, or 9, and
- OWN > 1 and
- MOA STATE ABBREVIATION ≠ AL, AK, AZ, AR, CA, CO, CT, DE, DC, FL, GA, HI, ID, IL, IN, IA, KS, KY, LA, ME, MD, MA, MI, MN, MS, MO, MT, NE, NV, NH, NJ, NM, NY, NC, ND, OH, OK, OR, PA, PR, RI, SC, SD, TN, TX, UT, VT, VA, VI, WA, WV, WI, WY, AS, GU, AE, AA, AP, CN, or ZZ.

Note: The system will not list the record for this flagged condition if there is at least one usable address.

111 — Mailing/Other Zip Code Format Check and Mailing/Other Zip Code Extension Format Check

General Description: The Physical/Location ZIP Code Format edit ensures that a proper ZIP Code is used in the Mailing/Other address block. The ZIP Code is a five-digit alphanumeric field. For U.S. addresses, this is the numeric code used by the Post Office for the specified address. For Canadian addresses, this field should contain the first five digits of the six-digit alphanumeric Canadian ZIP Code, while the Mailing/Other ZIP Code Extension field should contain the sixth digit followed by three blanks. The field is not edited for foreign addresses (designated by state abbreviation "ZZ").

This edit also ensures that the ZIP Code Extension field is properly used in the Mailing/Other address. The ZIP Code Extension is a four-digit alphanumeric field. For U.S. addresses that

have a ZIP Code Extension, the field should be strictly numeric. For Canadian addresses, the ZIP Code Extension begins with the last digit of the six-position alphanumeric Canadian ZIP Code; this position is numeric and is followed by three blanks. The field is not edited for foreign addresses (designated by state abbreviation "ZZ").

Edit code 111 is used for both the Mailing/Other ZIP Code Format Check and the Mailing/Other ZIP Code Extension Format Check.

Location: Both BLS & state systems	Level: Micro
Edit Level: 6	Edit Type: Warning
Priority: C	BLS Edit Publ. Criteria: Include, if flagged

Edit Message: *Unusable Mailing/Other ZIP Code Format*

Edit Conditions:

Bypass if any of the following conditions are met:

- STATUS = 2, 3, or 9, or
- OWN = 1 or
- CNTY = 996 or 998, or
- MOA STATE ABBREVIATION = AA, AE, AP, or ZZ, or
- MOA ZIP blank and all other mailing/other address fields blank. (A non-blank MOA ADDRESS TYPE should not be considered as part of the MOA address for this edit condition.)

Flag if all of the following conditions are met:

- MOA STATE ABBREVIATION = AL, AK, AZ, AR, CA, CO, CT, DE, DC, FL, GA, HI, ID, IL, IN, IA, KS, KY, LA, ME, MD, MA, MI, MN, MS, MO, MT, NE, NV, NH, NJ, NM, NY, NC, ND, OH, OK, OR, PA, PR, RI, SC, SD, TN, TX, UT, VT, VA, VI, WA, WV, WI, WY, AS, or GU, and
- (MOA ZIP nonnumeric, 00000, or 99999) or (MOA ZIP EXTENSION is nonnumeric or 9999), and
- $AME_C > ZIP-CODE-AME$.

Flag if all of the following conditions are met:

- MOA STATE ABBREVIATION = CN and
- (MOA ZIP numeric or blank) or (MOA ZIP EXTENSION \neq a numeric followed by 3 blanks), and
- $AME_C > ZIP-CODE-AME$.

Editing Parameters/Tolerances:

Parameter	Parameter Name	Length	EXPO PK #	WIN PK #	State Default	BLS Default
<i>ZIP-CODE-AME</i>	ZIP Code AME Cutoff	6	005	020	250	250

Note: The system will not list the record for this flagged condition if there is at least one usable address.

System Action: If the ZIP Code Extension is all zeros, the system will blank fill the field.

112 — Fax Number Check

General Description: The Fax Number edit checks for usable fax numbers for the account.

Location: Both state and BLS systems

Level: Micro

Edit Level: 6

Edit Type: Warning

Priority: C

BLS Edit Publ. Criteria: Include, if flagged

Edit Message: *Questionable Fax Number Format*

State System Actions and Edit Conditions:

Bypass if any of the following conditions occur:

- STATUS = 2, 3, or 9
- OWN = 1
- MEEI = 3 or 5
- FAX is all blank

Blank fill the FAX number if any of the following conditions occur: [Note that the AME parameter was removed. Fix all of these regardless of employment]

- FAX is all zeros, all ones, all twos, all threes, all fours, all fives, all sixes, all sevens, all eights, or all nines
- FAX = (any area code) + 555-1212
- FAX = "000" in positions 4-6
- FAX is not numeric in any of positions 4-10

Flag if $AME_C > FAX-AME$ and both of the following conditions occur:

- FAX = "000" in positions 1-3 or nonnumeric (including blank) in any position of 1-3 and FAX positions 4-10 are all numeric but not all zero

BLS Edit Conditions:

Bypass if any of the following conditions occur:

- STATUS = 2, 3, or 9
- OWN = 1
- MEEI = 3 or 5
- FAX is all blank

Flag if $AME_C > FAX-AME$ and any of the following conditions occur:

- FAX is all zeros, all ones, all twos, all threes, all fours, all fives, all sixes, all sevens, all eights, or all nines
- FAX = (any area code) + 555-1212

- FAX = “000” in positions 4-6
- FAX is not numeric in any of positions 4-10
- FAX = “000” in positions 1-3 or nonnumeric (including blank) in any position of 1-3 and FAX positions 4-10 are all numeric but not all zeroes

Editing Parameters/Tolerances:

Parameter	Parameter Name	Length	EXPO PK #	WIN PK #	State Default	BLS Default
<i>FAX-AME</i>	FAX AME	6	005	021	99	99

114 — Physical Address Format Check

General Description: Physical Location addresses, if provided, are required to use the state abbreviation of the reference state, to have a corresponding Zip Code, and to have at least one street address line. This edit also flags Post Office boxes in the PL address, since they do not identify a physical location. The edit flags records with a blank PL address if employment is high.

Location: Both BLS & state systems

Level: Micro

Edit Level: 6

Edit Type: Warning

Priority: C

BLS Edit Publ. Criteria: Include, if flagged

Edit Message: *P.O. Box, Blank Street, or Out-of-State in PLA Block*Edit Conditions:

Bypass if any of the following conditions occur:

- STATUS = 2, 3, or 9, or
- OWN = 1, or
- MEEI = 2, or
- AME_C ≤ *PHYS-ADDR-AME*.

Flag if both conditions occur:

- CNTY ≠ 996 or 998, and
- PLA STATE ABBREVIATION ≠ STATE ABBREVIATION of the reference/reporting state (not in-state).

Flag if all of the following conditions occur:

- PLA STREET ADDRESS - LINE 1 blank and
- PLA STREET ADDRESS - LINE 2 blank and
- PLA CITY not blank

Flag if either condition occurs:

- PLA STREET ADDRESS - LINE 1 includes P.O. Box or RR, or
- PLA STREET ADDRESS - LINE 2 includes P.O. Box or RR.
(I.e., checks for variations of P.O. Box and rural route addresses.)

Flag if both conditions occur:

- CNTY \neq 996 or 998, and
- PLA ZIP is not in the range of valid Zip codes for the reference state.

Flag if both conditions occur:

- CNTY \neq 996 or 998, and
- PLA ZIP is zero-filled, nine-filled, or contains any nonnumeric values.

Flag if both conditions occur:

- At least one other PL address field is not blank, and
- PLA ZIP is blank.

Flag if PLA CITY is equal to “Unknown” or “Statewide”.

Flag if both conditions occur:

- AMEc $>$ LARGE-PHYS-ADDR-AME, and
- All PL address fields are blank.

Note: For records with AMEc \leq LARGE-PHYS-ADDR-AME, the system will not list the record for this edit flag if there is at least one usable address.

Editing Parameters/Tolerances:

Parameter	Parameter Name	Length	EXPO PK #	WIN PK #	State Default	BLS Default
PHYS-ADDR-AME	Physical Location Address AME	6	006	022	5	5

116 — Missing Federal Employer Identification Number Check

General Description: The Missing Federal Employer Identification Number edit checks the EIN for questionable values and to determine if it has been missing for several quarters. The EIN is assigned to each employer by the IRS. Subunits should have the same EIN as their master record. The edit compares the month and year of the Setup Date against the earliest month of the reference quarter to see if the reporting unit has been in existence for more than a number of months based on a parm. If so, and if employment is large, then the reporting unit should have a specific (non-zero) EIN. If the Setup Date is blank, the edit uses the Liability Date.

Missing EINs are useless in any kind of research, sampling, and other critical uses of the field. Efforts should be made to attempt to contact the employer and obtain missing EINs for large employers.

Example:

Liability Date YYYYMM: 201701 (January 2017)
Setup Date YYYYMM: 201708 (August 2017)

First Month of Current Quarter: 201807 (July 2018)

In this example, the current quarter is the 2018 third quarter. If the parm is set at 6 months, 201708 < 201807 – "parm" months (the August 2017 Setup Date is earlier than the July 2018 beginning of the current quarter minus 6 months). Therefore, the reporting unit would flag if its EIN is still zero-filled. In other words, more than 6 months elapsed between the Setup Date (August 2017) and the first month of the current quarter (July 2018), so the edit expects to find a specific, valid EIN.

Location: Both BLS & state systems

Level: Micro

Edit Level: 6

Edit Type: Warning

Priority: A

BLS Edit Publ. Criteria: Include, if flagged

Edit Message: *EIN Missing for More Than Parm Months*

Edit Conditions:

Format = YYYYMMDD (where YYYY = year, MM = month, and DD = day).

Bypass if any of the following conditions are met:

- MEEI = 3 or 5, or
- STATUS = 2, 3, or 9, or
- OWN = 1, 2, or 3, or
- NAICS 814110, or
- COVERAGE = 8 or 9.

Flag if all of the following conditions are met:

- EIN = all zeros and
- $AME_c > EIN-AME$ and
- YYYYMM of the SETUP < YYYYMM of the first month of the current quarter – *EIN-MONTH* months. (If the SETUP is blank, then use the LIAB.)

Editing Parameters/Tolerances:

Parameter	Parameter Name	Length	EXPO PK #	WIN PK #	State Default	BLS Default
<i>EIN-AME</i>	EIN AME Parm	6	062	023	50	50
<i>EIN-MONTH</i>	EIN Months Missing	2	052	024	6	6

Note: This edit is required and must be run at least once each quarter.

System Action: The State systems have options to do the following:

- Suppress this edit from appearing on the online edit screens with the rest of the edits
- Suppress this edit from appearing on the same listings as the rest of the edits
- Allow this edit to be listed separately from the rest of the edit output
- Modify edit output and scoring formulae input to reflect the new priorities.

118 — Tax Rate Consistency Check

General Description: This check applies to only non-reimbursing, non-Federal ownership units – units with Type of Coverage Code 0 and Ownership Code greater than 1. Three states have employee contributions and are handled using an adjustment. Each reporting unit's Contributions must equal its Taxable Wages multiplied by its Tax Rate. California does not collect Taxable Wage information. Taxable Wages are derived by dividing Contributions Due by the Tax Rate after the annual reconciliation.

Location: State systems only

Edit Level: 6

Priority: C

Level: Micro

Edit Type: Warning

BLS Edit Publ. Criteria: Include, if flagged

Edit Message: *Computed Tax Rate > TOL % from Reported, and Computed Tax TOL from Reported*

Edit Conditions:

Bypass if any of the following conditions occur:

- OWN = 1
- STATUS = 2 or 9
- State-FIPS = 06, and CALIF-RATE-EDIT-BYPASS = 1

Flag if all of the following conditions occur:

- COVERAGE = 0 and
- $|CTB - (TAXW \times TAX\ RATE)| > MAX-CONTRIB-DEV$ and
- $|TAX\ RATE - (CTB \div TAXW)| > MAX-TAX-RATE-DEV$.

Flag if all of the following conditions are met:

- COVERAGE = 2 or 3, and
- $|CTB - (TAXW \times TAX\ RATE) - ADJUSTMENT| > MAX-CONTRIB-DEV$ and
- $|TAX\ RATE - (CTB \div TAXW) - ADJUSTMENT| > MAX-TAX-RATE-DEV$.

If state 42, ADJUSTMENT = TW × EMPLOYEE TAX RATE.

Editing Parameters/Tolerances:

Parameter	Parameter Name	Length	EXPO PK #	WIN PK #	State Default	BLS Default
MAX-TAX-RATE-DEV	Maximum Tax Rate Deviation	6	027	025	0.33% (expressed as 330 in EXPO and 0.33 in WIN)	N/A
MAX-CONTRIB-DEV	Maximum Contributions Due Deviation	6	028	026	2.50 (expressed as 000250 in EXPO and 2.5 in WIN)	N/A
EMPLOYEE-TAX-RATE	Employee Tax Rate	6	051	003	3% (expressed as 3000 in EXPO and 3.00 in WIN)	N/A
CALIF-RATE-EDIT-BYPASS	Bypass Switch For California Rate	1	N/A	027	0	N/A

119 — Missing Taxable Wage Check

General Description: This edit checks for high Total Wages when no Taxable Wages are reported. The edit is only performed in first quarter. All Contributory accounts are required to meet their Taxable Wage obligations beginning with each first quarter even if their tax rate may be zero and they pay no Contributions.

Location: Both BLS & state systems

Edit Level: 6

Priority: C

Level: Micro

Edit Type: Warning

BLS Edit Publ. Criteria: Include, if flagged

Edit Message: *First Quarter Taxable Wages Missing for Experienced-Rated Account*

Edit Conditions:

Bypass if OWN = 1.

Bypass if QTR ≠ 1.

Bypass if state-FIPS = 06 and CALIF-NO-TAXW-BYPASS = 1.

Flag if

- STATUS ≠ 2, 3, or 9, and
- TW > MAX-TOTW-NO-TAXW,
- COVERAGE = 0 or 2, and
- TAXW = 0.

Editing Parameters/Tolerances:

Parameter	Parameter Name	Length	EXPO PK #	WIN PK #	State Default	BLS Default
MAX-TOTW-NO-TAXW	Maximum Total Wages With No Taxable Wages	6	020	028	999,999	999,999
CALIF-NO-TAXW-BYPASS	Bypass Switch For California Taxable Wages	1	N/A	029	0	0

120 — Non-Economic Code Change Check

General Description: Changes to the classification codes (Ownership, NAICS, County, and – for some states – Township) are normally handled as either economic or noneconomic.

Noneconomic code changes, which are more frequent, must be held until first quarter and must carry an ARS Response Code and Refile Year that will place the record onto the CCS.

Economic code changes should be identified using the Economic Code Change Indicator (ECCI) or a comment code (code 82); these changes may be made in any quarter. Exceptions to these rules are made for master records as well as records with code changes only from an "unknown" industry or geographic code. This edit flags code changes on records with significant employment that are not properly coded as noneconomic or economic. The edit does not flag records with changes only from an "unknown" code; however, it flags code changes from a specific industry or geographic code to an "unknown" code in any quarter, since such changes are inappropriate. If the existing, specific code is wrong, identify the correct code and handle the change as a noneconomic code change.

Location: Both BLS & state systems
Edit Level: 6
Priority: B

Level: Micro
Edit Type: Warning
BLS Edit Publ. Criteria: Include, if flagged

Edit Message: *Possible Non-Economic Code Change*

Edit Conditions:

Bypass if $MEEI_c = 2$.

Bypass if $STATUS_c$ or $STATUS_p \neq 1$. (Edit only if the record is active in both the current and prior quarter.)

Bypass if both $M3_p$ and $M1_c \leq NECC-PARM$

Bypass if both $M3_p$ and $M1_c < ECCI-LRG-EMP-PARM$ and $COMMENT\ CODE_c = 82$.

Bypass the township portions of the edit if not New Jersey or a New England states (if $STATE \neq 09, 23, 25, 33, 34, 44, \text{ or } 50$).

The edit consists of two parts. Perform Part 1 if the processing quarter = 2, 3, or 4. (Edit only when the current quarter is a second, third, or fourth quarter.) Perform Part 2 if the processing quarter = 1 (Edit only when the current quarter is a first quarter). Part 2 includes its own bypass conditions – conditions that only apply if the processing quarter = 1. Both the first and second parts of the edit are performed in different ways, depending on employment. Where employment is significant but not large (greater than 25 but less than a 100), the edit does not flag a code change when the Employment Code Change Indicator carries the appropriate value.

Part 1

Flag if

- Processing quarter = (2, 3, or 4), and
- Both $M3_p$ and $M1_c < ECCI-LRG-EMP-PARM$, and
- At least one of the following code changes occurs in the current quarter compared with the prior quarter, and the change is not explained by the ECCI:

$OWN_p \neq OWN_c$ and ($ECCI \neq 04, 05, 06, 07, 12, 13, 14, \text{ or } 15$),

OR

$NAICS_p \neq NAICS_c$ and $NAICS_p \neq 999999$ and ($ECCI \neq 02, 03, 06, 07, 10, 11, 14, \text{ or } 15$),

OR

$CNTY_p \neq CNTY_c$ and $CNTY_p \neq 900-999$ and ($ECCI \neq 08, 09, 10, 11, 12, 13, 14, \text{ or } 15$),

OR

$TOWN_p \neq TOWN_c$ and ($TOWN_p \neq 900, 995, 996, 998, \text{ or } 999$) and ($STATE = 09, 23, 25, 33, 34, 44, \text{ or } 50$) and ($ECCI \neq 01, 03, 05, 07, 09, 11, 13, \text{ or } 15$).

(In other words, current ownership is not equal to prior ownership or current NAICS is not equal to prior NAICS or current county is not equal to prior county or (for certain states) current township is not equal to prior township, and in each case the prior quarter is not the fourth quarter. Disregard any NAICS, ownership, county, and township changes from the “unknown” codes. Disregard any code changes identified by an appropriate ECCI value.)

Flag if

- Processing quarter = (2, 3, or 4), and
- Either $M3_p$ or $M1_c \geq ECCI-LRG-EMP-PARM$, and
- At least one of the following code changes occurs in the current quarter compared with the prior quarter, regardless of the ECCI:
 - $OWN_p \neq OWN_c$, or
 - $NAICS_p \neq NAICS_c$ and $NAICS_p \neq 999999$, or
 - $CNTY_p \neq CNTY_c$ and $CNTY_p \neq 900-999$, or
 - $TOWN_p \neq TOWN_c$ and ($TOWN_p \neq 900, 995, 996, 998, \text{ or } 999$) and ($STATE = 09, 23, 25, 33, 34, 44, \text{ or } 50$).

(In other words, current ownership is not equal to prior ownership or current NAICS is not equal to prior NAICS or current county is not equal to prior county or (for certain states) current township is not equal to prior township, and in each case the prior quarter is not the fourth quarter. Disregard any NAICS, ownership, county, and township changes from the “unknown” codes.)

Flag if either of the following occur

- $NAICS_c = 999999$ and $NAICS_p < 999999$, or
- $COUNTY_c = 999$ and $COUNTY_p < 900$.

Part 2

Bypass if $ARS\ REFILE\ YEAR =$ current Refiling Year and $RESPONSE\ CODE = 46$ or 50 (in the BLS System: $RESPONSE\ CODE = 30, 33, 46$ or 50).

Flag if

- Processing quarter = 1, and
- Both $M3_p$ and $M1_c < ECCI-LRG-EMP-PARM$, and
- At least one of the following code changes occurs in the current quarter, compared with the prior quarter, and the change is not explained by the ECCI:

$OWN_p \neq OWN_c$ and ($ECCI \neq 04, 05, 06, 07, 12, 13, 14, \text{ or } 15$),

OR

$NAICS_p \neq NAICS_c$ and $NAICS_p \neq 999999$ and ($ECCI \neq 02, 03, 06, 07, 10, 11, 14, \text{ or } 15$),

OR

$CNTY_p \neq CNTY_c$ and $CNTY_p \neq 900-999$ and ($ECCI \neq 08, 09, 10, 11, 12, 13, 14, \text{ or } 15$),

OR

TOWN_p ≠ TOWN_c and (TOWN_p ≠ 900, 995, 996, 998, or 999) and (STATE = 09, 23, 25, 33, 34, 44, or 50) and (ECCI ≠ 01, 03, 05, 07, 09, 11, 13, or 15).

(In other words, current ownership is not equal to prior ownership or current NAICS is not equal to prior NAICS or current county is not equal to prior county or (for certain states) current township is not equal to prior township, and in each case the current quarter is the first quarter. Disregard any NAICS, ownership, county, and township changes from the “unknown” codes. Disregard any code changes identified by an appropriate ECCI value.)

Flag if

- Processing quarter = 1, and
- Either M3_p or M1_c ≥ *ECCI-LRG-EMP-PARM*, and
- At least one of the following code changes occurs in the current quarter, compared with the prior quarter, regardless of the ECCI:
 - OWN_p ≠ OWN_c, or
 - NAICS_p ≠ NAICS_c and NAICS_p ≠ 999999, or
 - CNTY_p ≠ CNTY_c and CNTY_p ≠ 900-999, or
 - TOWN_p ≠ TOWN_c and (TOWN_p ≠ 900, 995, 996, 998, or 999) and (STATE = 09, 23, 25, 33, 34, 44, or 50).

(In other words, current ownership is not equal to prior ownership or current NAICS is not equal to prior NAICS or current county is not equal to prior county or (for certain states) current township is not equal to prior township, and in each case the current quarter is the first quarter. Disregard any NAICS, ownership, county, and township changes from the “unknown” codes.)

Flag if either of the following occur

- NAICS_c = 999999 and NAICS_p < 999999, or
- COUNTY_c = 999 and COUNTY_p < 900.

Editing Parameters/Tolerances:

Parameter	Parameter Name	Length	EXPO PK #	WIN PK #	State Default	BLS Default
<i>NECC- PARM</i>	Noneconomic Code Change Monthly Employment Parm	2	009	030	25	25
<i>ECCI- LRG-EMP- PARM</i>	Economic Code Change Large Employment Parm	6	N/A	098	50	100

121 — Reversed Code Change Check

General Description: This edit captures very mobile units that keep reversing code changes. This edit is a supplement to edit 120.

Location: Both BLS & state systems	Level: Micro
Edit Level: 6	Edit Type: Warning
Priority: B	BLS Edit Publ. Criteria: Include, if flagged

Edit Message: *Code Change Back to a Recent Code*

Edit Conditions:

Bypass if MEEI = 2.

Bypass if STATUS_C or STATUS_P ≠ 1. (Edit only if active in both the current and prior quarter.)

Bypass the township portions of the edit if not New Jersey or a New England states (CT, ME, MA, NH, RI, and VT).

Flag if AME_C > REVS-CCS and any of the following occur:

- NAICS_C ≠ NAICS_P and NAICS_C = NAICS in any of the three previous quarters, or
- TOWN_C ≠ TOWN_P and TOWN_C = TOWN in any of the three previous quarters, or
- CNTY_C ≠ CNTY_P and CNTY_C = CNTY in any of the three previous quarters, or
- OWN_C ≠ OWN_P and OWN_C = OWN in any of the three previous quarters.

Editing Parameters/Tolerances:

Parameter	Parameter Name	Length	EXPO PK #	WIN PK #	State Default	BLS Default
REVS-CCS	Rev CCS AME	6	009	094	100	100

123 — CCS Edit Checks

General Description: This edit checks for a missing noneconomic code change. When the Response Code and ARS Refile Year indicate that a noneconomic code change is present on the record, the edit compares the Old Fields to the first quarter classification codes to verify the code change. (Changes only from unknown industry or county codes are not considered noneconomic, and are not sufficient to pass the edit.)

Location: Both BLS & state systems	Level: Micro
Edit Level: 6	Edit Type: Warning
Priority: B	BLS Edit Publ. Criteria: Include, if flagged

Edit Message: *Expected Code Change Not Made*

Edit Conditions:

Bypass if MEEI of the most recent 1st quarter = 2 or MEEI of the most recent 4th quarter = 2.
(For example, for 2018/1 processing, bypass if MEEI =2 in either 2018/1 or in 2017/4.)

Bypass if STATUS_c or STATUS_p ≠ 1. (Edit only if active in both the current and prior quarter.)

Flag if all of the following occur:

- QTR = 1 and
- ARS RESPONSE CODE = (50 or 46), and [In the BLS system, ARS RESPONSE CODE = 30, 33, 46 or 50] and
- ARS REFILE YEAR = processing year and
- OLD NAICS = (NAICS_c or blank or 999999) and
- OLD CNTY = (CNTY_c or blank or 900-999) and
- OLD TOWN = (TOWN_c or blank or 900-999) and
- OLD OWN = (OWN_c or blank) and

The BLS system only performs this edit when the processing quarter is first quarter.

124 — Active Account Check

General Description: The Active Account edit checks to determine if a QCR or MWR has reported employment and wage data for the quarter, when the unit was coded out-of-business or inactive. This edit is used to ensure that there are no records with reported or imputed employment or wages, with an End Of Liability date or Status Code that indicates that it is out-of-business or inactive. The records that should be most closely examined are those with sizable employment that are coded as inactive or out-of-business to ensure that the record should truly be considered inactive. Data for inactive records are not used for any application or aggregation.

Location: Both BLS & state systems

Level: Micro

Edit Level: 6

Edit Type: Warning

Priority: C

BLS Edit Publ. Criteria: Include, if flagged

Edit Message: *Inactive Record with Reported Employment/Wage Data*

Edit Conditions:

Bypass if EOL is blank.

Flag if the economic data exceeds either of these thresholds:

- Any monthly EMPLOYMENT for the current quarter (M_C) > *ACTIV-AME* or
- $TW_C > ACTIV-WAGE$

and

if either the date fields or the Status Code show that the unit is closed:

- $EOL < \text{reference period where the EOL date is}$ > non blank REACT or
- Where STATUS = 2.

Editing Parameters/Tolerances:

Parameter	Parameter Name	Length	EXPO PK #	WIN PK #	State Default	BLS Default
<i>ACTIV-AME</i>	Active Account AME	2	009	032	99	99
<i>ACTIV-WAGE</i>	Active Account Total Wages	6	019	033	500,000	500,000

125 — Liability Check

General Description: The Liability edit checks to determine if a QCR or MWR was received with reported employment and wage data prior to the unit's Liability Date. This edit is used to ensure that there are no new records on the file that have a liability date that is after the reference quarter.

Location: Both BLS & state systems

Edit Level: 6

Priority: C

Level: Micro

Edit Type: Warning

BLS Edit Publ. Criteria: Include, if flagged

Edit Message: *Data Reported Prior to Liability Date*

Edit Conditions:

The system determines the earlier of Setup Date and Liability Date and uses the earlier date in the edit. If only one of the dates is available, the system will use it.

Bypass if neither SETUP nor LIAB is present.

Flag if all of the following occur:

- $STATUS_C = 1$ and
- $AME > LIAB-AME$ or $TW > LIAB-WAGE$ and
- ($SETUP$ or $LIAB > \text{the last day of the QTR}$) or ($EOL DATE < \text{first day of the QTR}$ and $REACT > \text{the last day of the QTR}$).

Editing Parameters/Tolerances:

Parameter	Parameter Name	Length	EXPO PK #	WIN PK #	State Default	BLS Default
LIAB-AME	Liability Check Employment	2	009	034	99	99
LIAB-WAGE	Liability Check Wages	6	055	035	500,000	500,000

126 — Monthly Employment Change Check

General Description: This is the same edit as 091, but with a smaller threshold for the difference between current and prior employment. If the difference between the current and prior average monthly employment is greater than a parameter times a multiplier, the system will code as edit 091. If not, the system will code as edit 126.

Note: This edit does not appear in the WIN-202 System. The WIN-202 System uses edit codes 136, 137, and 138 instead.

See edit 091 for a full description.

Location: Both BLS & EXPO

Edit Level: 6

Priority: A

Level: Micro & Macro

Edit Type: Warning

BLS Edit Publ. Criteria: Include, if flagged

Edit Message: *Employment Change Exceeds Test Parameters*

Edit Conditions: See Edit 091 for details and parameter values.

127 — Wage Change Check

General Description: This is the same as edit 092, but with a smaller threshold for the difference between current and previous Average Quarterly Wage. If the difference is greater than a parameter times a multiplier, then the system will code as edit 092. If not, the system will code as edit 127.

See edit 092 for a full description.

Location: Both BLS & state systems

Edit Level: 6

Priority: A

Level: Micro & Macro

Edit Type: Warning

BLS Edit Publ. Criteria: Include, if flagged

Edit Message: *AQW Change > Parm and Exceeds Twice the Quartile AQW Range*

Edit Conditions: See Edit 092 for details and parameter values.

128 — Identical Monthly Employment Check

General Description: The Identical Monthly Employment edit looks for situations in which all three months show the same level of employment within the quarter, while current and prior quarter employment both exceed a parameter and none of the months is imputed. This helps ensure valid reporting of employment for each month. Identical monthly reporting frequently occurs when the employer reports

- The end of the quarter count in all three months each quarter
- A current employee count at the time the report is completed
- The last month's data in all three months

The employer should be contacted and advised on proper reporting procedures.

Location: Both BLS & state systems

Level: Micro

Edit Level: 6

Edit Type: Warning

Priority: C

BLS Edit Publ. Criteria: Include, if flagged

Edit Message: *Identical Monthly Employment > Parm*

Edit Conditions:

Flag if all of the following occur:

- STATUS ≠ 2, 3, or 9, and
- MEEI = 1, 2, 4 or 6, and
- $AME_c > MAX-IDENT-EMPL$ and
- $AME_p > MAX-IDENT-EMPL$ and
- $M1_c = M2_c = M3_c$ and
- $M1_p = M2_p = M3_p$ and
- $M1_c-IND$ nor $M2_c-IND$ nor $M3_c-IND = E, H,$ or K and
- $M1_p-IND$ nor $M2_p-IND$ nor $M3_p-IND = E, H,$ or K

Note: This edit is required and must be run at least once each quarter.

Editing Parameters/Tolerances:

Parameter	Parameter Name	Length	EXPO PK #	WIN PK #	State Default	BLS Default
<i>MAX-IDENT-EMPL</i>	Maximum Identical Employment AME	6	021	036	1,000	1,000

System Action: The State systems have options to do the following:

- Suppress this edit from appearing on the online edit screens with the rest of the edits
- Suppress this edit from appearing on the same listings as the rest of the edits
- Allow this edit to be listed separately from the rest of the edit output

129 — Taxable/Total Wage Change Check

General Description: The Taxable/Total Wage Change edit checks the ratio of taxable wages to total wages. A record is questionable if the ratio is outside the acceptable range based on the taxable wage-to-total wage ratio from current quarter a year ago plus or minus the tolerance.

Location: Both BLS and state systems	Level: Micro
Edit Level: 6	Edit Type: Warning
Priority: C	BLS Edit Publ. Criteria: Include, if flagged

Edit Message: *Taxable/Total Wage Ratio > Prior Year Ratio by Parm %*

Edit Conditions:

Bypass if STATUS = 2, 3, or 9.

Bypass if TW_C or $TW_{CY} = 0$.

Flag if

- $AME_C > TAXW-TOTW-CHG-AME$ and
- $|(TAXW_C \div TW_C) - (TAXW_{CY} \div TW_{CY})| > TAXW-TOTW-CHG-PCT$.

Editing Parameters and Tolerances:

Parameter	Parameter Name	Length	EXPO PK #	WIN PK #	State Default	BLS Default
<i>TAXW-TOTW-CHG-PCT</i>	Taxable Wages To Total Wages Percent Tolerance	2	043	037	99	99
<i>TAXW-TOTW-CHG-AME</i>	Taxable Wages To Total Wages AME	6	044	038	500	500

130 — Employment Without Wages Check

General Description: This edit is the same as edit 093 but with a smaller threshold.

See edit 093 for a full description.

Location: Both BLS & state systems	Level: Micro & Macro
Edit Level: 6	Edit Type: Warning
Priority: A	BLS Edit Publ. Criteria: Include, if flagged

Edit Message: *Average Employment > Parm, but Total Wages = 0*

Edit Conditions: See Edit 093 for details and parameter values.

131 — Wages Without Employment

General Description: This edit is the same as edit 094 but with a smaller threshold.

See edit 094 for a full description.

Location: Both BLS & state systems	Level: Micro & Macro
Edit Level: 6	Edit Type: Warning
Priority: A	BLS Edit Publ. Criteria: Include, if flagged

Edit Message: *Average Employment = 0, but Total Wages > Parm*

Edit Conditions: See Edit 094 for details and parameter values.

132 — Wages/Employment Sum Check

General Description: This edit is the same as 095 but with a smaller threshold.

See edit 095 for a full description.

Location: Both BLS & state systems	Level: Micro
Edit Level: 6	Edit Type: Warning
Priority: A	BLS Edit Publ. Criteria: Include, if flagged

Edit Message: *Total Wages = Sum of Empl +/- Parm*

Edit Conditions: See Edit 095 for details and parameter values.

133 — Unclassified Industry Check

General Description: The unclassified industry check looks for situations in which the average monthly employment of the current period is greater than a parm, and NAICS is 999999 for two quarters. This edit encourages states to assign valid, specific NAICS to records with high employment. Unclassified records cannot be properly aggregated to their correct industry and have more limited use in data analysis and publications.

Location: Both BLS & state systems	Level: Micro
Edit Level: 6	Edit Type: Warning
Priority: A	BLS Edit Publ. Criteria: Include, if flagged

Edit Message: *Unclassified Industry, Empl > Parm*

Edit Conditions:

Flag if

- STATUS \neq 2, 3, or 9, and
- NAICSc = 999999 and
- NAICSp = 999999 and
- AMEc > UNCLASS-MAX-AME

Editing Parameters and Tolerances:

Parameter	Parameter Name	Length	EXPO PK #	WIN PK #	State Default	BLS Default
UNCLASS- MAX-AME	Unclassified Industry AME	2	018	039	50	50

134 — Number of Establishments Change Check

General Description: The Number of Establishments Change edit looks for large fluctuations in the number of reporting units in the macro cell in the current quarter, as compared to the previous quarter. During first quarter processing, this edit is not done until after the data are temporarily adjusted based on the net change of the Summary of Differences data for the cell (if any); this is part of the process called Code Change Integration.

A significant change in the number of establishments could represent growth in the industry and county, may result from a large employer breakout into multi-establishment reporting, or may result from an unexpected mid-year reporting problem or unusual predecessor/successor reporting situation.

Location: Both BLS & state systems

Level: Macro

Edit Level: 6

Edit Type: Summed Level/Warning

Priority: A

BLS Edit Publ. Criteria: Include, if flagged

Edit Message: *Number of Establishments Out Of Range*Edit Conditions:

Bypass if any of the following conditions are true:

- AMEc < 25 or
- AMEp < 25 or
- NUMBER OF ESTABLISHMENTSp = 0 or
- NUMBER OF ESTABLISHMENTSc = 0 or

Flag if either or both pairs of conditions are true:

(1)

- $0 < \text{NUMBER OF ESTABLISHMENTSp} \leq 32$ and
- $|\text{NUMBER OF ESTABLISHMENTSc} - \text{NUMBER OF ESTABLISHMENTSp}| > 8$

OR

(2)

- NUMBER OF ESTABLISHMENTS_p > 32 and
- |NUMBER OF ESTABLISHMENTS_c - NUMBER OF ESTABLISHMENTS_p| > NUMBER OF ESTABLISHMENTS_p × 0.25

135 — New and Discontinued Macro Record Checks

General Description: The New and Discontinued Macro Record edit checks for whole macro cells that never existed before or cease to exist. Macro cells with small employment are not flagged. (Note: New and discontinued micro conditions can be found in edits 096, 097, 139, and 140.)

Micro level predecessor/successor situations should not normally explain new and discontinued problems at the macro level. In most cases, the predecessor and successor should be reported in the same macro cells unless the change is included on the Code Change Supplement.

Location: Both BLS & state systems

Edit Level: 6

Priority: A

Level: Macro

Edit Type: Summed Level/Warning

BLS Edit Publ. Criteria: Include, if flagged

Edit Message: *New or Discontinued Macro Record*Edit Conditions:

Flag if the following conditions are true:

- AME_p > MACRO-DISCONTINUED-AME
- NUMBER OF ESTABLISHMENTS_c = 0

OR

Flag if the following conditions are true:

- AME_c > MACRO-NEW-AME
- NUMBER OF ESTABLISHMENTS_p = 0

Editing Parameters and Tolerances:

Parameter	Parameter Name	Length	EXPO PK #	WIN PK #	State Default	BLS Default
MACRO-DISCONTINUED-AME	New and Discontinued Macro Record	6	054	040	100	100
MACRO-NEW-AME	Macro New Record AME	6	054	041	100	100

136 — Monthly Employment Change Check - Month 1 (WIN-202)

General Description: This is the same edit as 091, but with a smaller threshold for the difference between current and prior employment. If the difference between the current and prior average monthly employment is greater than the parameter times a multiplier, the system will code as edit 089. If not, the system will code as edit 136.

Note: This edit does not appear in either EXPO or the BLS System. These systems use edit 126 instead.

See edit 091 for a full description.

Location: WIN-202 Only
Edit Level: 6
Priority: A

Level: Micro & Macro
Edit Type: Warning
BLS Edit Publ. Criteria: Include, if flagged

Edit Message: *Month 1 Employment Change Exceeds Test Parameters*

Edit Conditions: See Edit 091 for details and parameter values.

137 — Monthly Employment Change Check - Month 2 (WIN-202)

General Description: This is the same edit as 091, but with a smaller threshold for the difference between current and prior employment. If the difference between the current and prior average monthly employment is greater than the parameter times a multiplier, the system will code as edit 090. If not, the system will code as edit 137.

Note: This edit does not appear in either EXPO or the BLS System. These systems use edit 126 instead.

See edit 091 for a full description.

Location: WIN-202 Only
Edit Level: 6
Priority: A

Level: Micro & Macro
Edit Type: Warning
BLS Edit Publ. Criteria: Include, if flagged

Edit Message: *Month 2 Employment Change Exceeds Test Parameters*

Edit Conditions: See Edit 091 for details and parameter values.

138 — Monthly Employment Change Check - Month 3 (WIN-202)

General Description: This is the same edit as 091, but with a smaller threshold for the difference between current and prior employment. If the difference between the current and prior average monthly employment is greater than the parameter times a multiplier, the system will code as edit 091. If not, the system will code as edit 138.

Note: This edit does not appear in either EXPO or the BLS System. These systems use edit 126 instead.

See edit 091 for a full description.

Location: WIN-202 Only
Edit Level: 6
Priority: A

Level: Micro & Macro
Edit Type: Warning
BLS Edit Publ. Criteria: Include, if flagged

Edit Message: Month 3 Employment Change Exceeds Test Parameters

Edit Conditions: See Edit 091 for details and parameter values.

139 — New Record Check

General Description: This is a small employment version of edit 096 described earlier in this appendix. It uses a smaller (but still significant) employment cutoff.

See edit 096 for a full description.

Location: Both BLS & state systems
Edit Level: 6
Priority: A

Level: Micro
Edit Type: Warning
BLS Edit Publ. Criteria: Include, if flagged

Edit Message: *New Record?*

Conditions: See Edit 096 for details and parameter values.

140 — Discontinued Record Check

General Description: This is a small employment version of edit 097. The Discontinued Record edit flags accounts that have just gone inactive, show no successor account, and had a sizable employment when they terminated. This is the counterpart of edit 139, but is not as sophisticated. This is one of the few edits that applies only to currently inactive employers.

See edit 097 for a full description.

Location: Both state & BLS systems

Edit Level: 6

Priority: A

Level: Micro

Edit Type: Warning

BLS Edit Publ. Criteria: Include, if flagged

Edit Message: *Discontinued Record?*

Edit Conditions: See Edit 097 for details and parameter values.

146 — Inconsistent Old Code Check

General Description: This edit checks the non-quarterly Old fields to verify that they match the fourth quarter classification codes. This edit is only performed when the Response Code and ARS Refile Year qualify the record to be included on the CCS, and only when the fourth quarter is active.

Location: Both BLS & state systems

Edit Level: 6

Priority: B

Level: Micro

Edit Type: Warning

BLS Edit Publ. Criteria: Include, if flagged

Edit Message: *Old Codes Are Inconsistent with 4th Quarter Codes*

Edit Conditions:

IN THE BLS SYSTEM:

Bypass if any of the following occur:

- QTR = 1 and STATUS = 3 or
- MEEI of the most recent first quarter = 2 or if the MEEI of the most recent fourth quarter = 2 or
- The fourth quarter prior year STATUS \neq 1 or
- ARS REFILE YEAR \neq FISCAL-YEAR or
- RESPONSE CODE \neq 30, 33, 46 or 50, or
- OLD OWN, OLD NAICS, and OLD CNTY are all blank, or
- Edit Flags for 074, 075, 076, or 078 have been assigned, or
- AMEc < OLD-CODE-CUTOFF.

Flag if any of the following occur:

- Non-blank OLD OWN \neq OWN of the active 4th quarter of the prior year or
- Non-blank OLD NAICS \neq NAICS of the active 4th quarter of the prior year or

- Non-blank OLD CNTY \neq CNTY of the active 4th quarter of the prior year or
- If STATE = 09, 23, 25, 33, 34, 44, or 50, non-blank OLD TOWN \neq TOWN of the active 4th quarter of the prior year.

IN STATE SYSTEMS:

No flag or edit message is used.

System Action:

In state systems, if any Old field is different from the valid code of the active fourth quarter of the prior year, then the system replaces it with the valid code of the active fourth quarter of the prior year. (Note: if fourth quarter of the prior year was not active, then Old fields are not replaced.) These are the Old fields that should be replaced:

- OLD CNTY
- OLD TOWN
- OLD OWN
- OLD NAICS

If the CCS is locked, the system will not run this edit.

Edit Parameters/Tolerances:

Parameter	Parameter Name	Length	EXPO PK #	WIN PK #	State Default	BLS Default
<i>FISCAL-YEAR</i>	Fiscal Year	4	—	—	Processing or fiscal year for current refiling	Current processing year, or fiscal year for the refiling just completed
<i>OLD-CODE-CUTOFF</i>	Old Code Cutoff	6	N/A	N/A	N/A	50

Level 7 Edit Descriptions – Predecessor/Successor Edits

Predecessor/Successor edits are designed to identify potential relationship problems between predecessor and successor units. In these cases, either the predecessor of a new or merged unit is identified and/or the successor of a partially or completely discontinued unit is identified.

Level 7 edits identify two general types of errors, code discrepancies and suspect economic data.

First, a comparison of the predecessor's and successor's data fields may show unexpected differences in one of the following codes:

- Ownership
- County
- Township (for certain states)
- NAICS

Usually, the codes of the predecessor and successor are the same unless the successor had an immediate economic code change at the time of the ownership transfer. If there was a non-economic code change (e.g., the predecessor was incorrectly coded and the successor is assigned the correct code), the change should be held until first quarter unless the employment level is less than 25. The parameters used in these edits should exclude these smaller units. If the code change should be held, follow instructions in Chapter 5 of this manual.

The second type of error is an overlap or gap in reporting economic data. When both the predecessor and successor – or neither the predecessor nor the successor – reported during the reference period, there is either an overlap or a gap in reporting.

When the predecessor and successor both have employment and wages, one of the following has generally occurred:

- One of the units was imputed and the imputed record should have been inactivated, or
- Both the predecessor and successor reported, and only one should have. To correct this,
 - The predecessor should have had the employment and wages changed to zero, or
 - the predecessor should be inactivated for the reference period, or
 - the successor should have its employment and wages changed to zero and the record coded as pending until the appropriate quarter when it would be activated.
- The ownership transfer occurred in the middle of the reference period and the information should be either
 - merged under one unit, or
 - properly explained using numeric or narrative comments.
- A partial transfer of some of the assets of the business was sold to another business resulting in both reporting part of the employment and wages. When this occurs,
 - the sum of each month of employment and the sum of the wages should be comparable to the amount of employment and wages the business had prior to the transfer.

If neither the predecessor nor the successor reported during the reference period, it should be determined

- If the business' employees continued to work during this time period, and if so,
- Who paid their wages.

The appropriate record's data should be either reported or imputed based on the data of the predecessor's last report.

Because the procedures for the predecessor/successor edits are very similar, the edit conditions for all the edits are combined. The record would receive the appropriate edit message for each edit flagged.

156 — Predecessor/Successor County Code Change Conflict Edit

General Description: The Predecessor/Successor County Code Change Conflict edit checks to see that predecessors and successors have the same county codes. Like ownership codes, township codes, and NAICS codes, the County Code is generally expected to remain the same. It is generally assumed that a one-to-one predecessor-to-successor transfer should not require a change in county code. Noneconomic code changes are allowed in first quarter only, so County Code differences will not be flagged in first quarter if the record is on the ARS and has a response code indicating a code change. Also, County Code changes will not be flagged if the Economic Code Change Indicator shows that there has been an economic code change.

Location: Both BLS & state systems

Level: Micro

Edit Level: 7

Edit Type: Warning

Priority: B

BLS Edit Publ. Criteria: Include, if flagged

Edit Message: *Predecessor/Successor County Code Change Conflict*

Edit Conditions: See Predecessor/Successor edit conditions in Predecessor/Successor later in this chapter.

157 — Predecessor/Successor Ownership Code Change Conflict Edit

General Description: The Predecessor/Successor Ownership Code Change Conflict edit checks to see that predecessors and successors have the same ownership codes. Like county codes, township codes, and NAICS codes, the Ownership Code is generally expected to remain the same. This condition is the code change least likely to occur, since government-controlled agencies generally remain under government control through a transition, and privately owned businesses usually stay privately owned. A possible exception occurs when a government transfers its reporting responsibilities to a professional employee leasing company. In these cases, even if the employees continue to perform their activities for the government installation, the employees are paid by the leasing company and are coded with a private sector ownership code. Noneconomic code changes are allowed in first quarter only, so Ownership Code differences will not be flagged in first quarter if the record is on the ARS and has a response code indicating a code change. Also, Ownership Code changes will not be flagged if the Economic Code Change Indicator shows that there has been an economic code change.

Location: Both BLS & state systems	Level: Micro
Edit Level: 7	Edit Type: Warning
Priority: B	BLS Edit Publ. Criteria: Include, if flagged

Edit Message: *Predecessor/Successor Ownership Change Conflict*

Edit Conditions: See Predecessor/Successor edit conditions in Predecessor/Successor later in this chapter.

159 — Predecessor/Successor Township Code Change Conflict Edit

General Description: The Predecessor/Successor Township Code Change Conflict edit checks to see that predecessors and successors have the same township codes. Like county codes, ownership codes, and NAICS codes, the Township Code (required for New England states and New Jersey) is generally expected to remain the same. This edit is only performed for New England states (Connecticut, Maine, Massachusetts, New Hampshire, Rhode Island, and Vermont) and New Jersey. Noneconomic code changes are allowed in first quarter only, so Township Code differences will not be flagged in first quarter if the record is on the ARS and has a response code indicating a code change. Also, Township Code changes will not be flagged if the Economic Code Change Indicator shows that there has been an economic code change.

Location: Both BLS & state systems	Level: Micro
Edit Level: 7	Edit Type: Warning
Priority: B	BLS Edit Publ. Criteria: Include, if flagged

Edit Message: *Predecessor/Successor Township Code Change Conflict*

Edit Conditions: See Predecessor/Successor edit conditions in Predecessor/Successor later in this chapter.

160 — Predecessor/Successor Overlap Edit

General Description: The Predecessor/Successor Employment Overlap edit checks to see if both the predecessor and the successor have reported or estimated employment for the same month of the reference period. The edit examines three months of employment in the current and month 3 of the prior quarter to find overlapping data (namely, non-zero employment for the same month in both the predecessor and successor). Whenever there is more than one predecessor and/or more than one successor, the sum of the employment across all predecessors and successors should be used.

Location: Both BLS & state systems	Level: Micro
Edit Level: 7	Edit Type: Warning
Priority: A	BLS Edit Publ. Criteria: Include, if flagged

Edit Message: *Both Predecessor and Successor Reported*

Edit Conditions: See Predecessor/Successor edit conditions in Predecessor/Successor later in this chapter.

161 — Predecessor/Successor Employment Gap Edit

General Description: The Predecessor/Successor Employment Gap edit checks to see if neither the predecessor nor the successor reported or estimated employment for a period of time. As the flip side of the overlap check, the edit looks for a gap in employment between the predecessor and successor. This means that one month shows non-zero data in the predecessor, the following months thereafter show zero data in both accounts, and one of the next couple of months thereafter shows non-zero data in the successor account. Therefore, for a period of one month, neither the predecessor nor the successor shows any employees present. (Note: Whenever there is more than one predecessor and/or more than one successor, all predecessors and successors should be examined to determine whether there is a gap in employment.)

There are only four months of data used, the third month of the prior quarter and the three months of the processed quarter. Four possible combinations can exist to produce this edit exception. The first case would be the combination of non-zero employment for the predecessor in the third month of the prior quarter, zero data in the first month of the processed quarter for both accounts, and non-zero employment in the second month of the quarter for the successor account. The second case would be the combination of non-zero employment for the predecessor in the third month of the prior quarter, zero data in the first and second month of the processed quarter for both accounts, and non-zero employment in the third quarter for the successor account. Similarly, the third case, dealing strictly with the processed quarter, would show non-zero data for the predecessor in the first month, zero data for both accounts in the second month, and non-zero employment for the successor in the third month of the quarter. Finally, this edit flags large records that have predecessor or successor information but do not match to another record.

Location: Both BLS & state systems

Edit Level: 7

Priority: **A**

Level: Micro

Edit Type: Warning

BLS Edit Publ. Criteria: Include, if flagged

Edit Message: *Neither Predecessor nor Successor Reported*

Edit Conditions: See Predecessor/Successor edit conditions in Predecessor/Successor later in this chapter.

164 — Predecessor/Successor NAICS Code Change Conflict Edit

General Description: The Predecessor/Successor NAICS Code Change Conflict edit checks to see that predecessors and successors have the same NAICS codes. Like county codes, township codes, and ownership codes, the NAICS Code is generally expected to remain the same. Noneconomic code changes are allowed in first quarter only, so NAICS code differences will not be flagged in first quarter if the record is on the ARS and has a response code indicating a code

change. Also, NAICS Code changes will not be flagged if the Economic Code Change Indicator shows that there has been an economic code change.

Location: Both BLS & state systems	Level: Micro
Edit Level: 7	Edit Type: Warning
Priority: B	BLS Edit Publ. Criteria: Include, if flagged

Edit Message: *Predecessor/Successor NAICS Code Change Conflict*

Edit Conditions: See Predecessor/Successor edit conditions below.

F.6.1 Predecessor/Successor Edits

Edit Conditions:

Definitions:

Y - current record

X – record(s) linked to Y using Y's predecessor UI# and RUN

Z – record(s) linked to Y using Y's successor UI# and RUN

ARS - ARS Refile Year

RC - ARS Response Code

ECCI - Economic Code Change Indicator

Note that there are the following 4 possible predecessor/successor scenarios:

1. One predecessor and one successor
2. One predecessor and many successors
3. Many predecessors and one successor
4. Many predecessors and many successors

Whenever there is more than one predecessor and/or successor, create an “aggregated” record that is the sum of the multiple predecessors or successors. These aggregated records will be used in the predecessor and successor checks.

Also, when a condition is checked in the edit such as “STATUS Y_c = 1”, if Y_c is an aggregate record, then the condition only needs to be met by at least one of the records that were aggregated. The aggregate record should then be modified so that it only includes records that meet the specified conditions. The employment for the aggregate record should be the sum of employment for all of the records that were aggregated.

For example, in the Predecessor Check below, if an aggregate record needs to be created, do not include any records that do not meet all of the four conditions listed below.

A. Predecessor Check

Check:

- $STATUS_Y_c = 1$
- $STATUS_Y_p \neq 1$
- Y's Predecessor UI# \neq blank
- Y's Predecessor RUN \neq blank

If one or more the conditions is false, bypass the rest of the edit

If all four conditions are true, do the following steps in the predecessor check:

1. Calculate FirstY and FirstempY:

FirstY = 1st active month in which there is non-zero employment in record Y
(emp>0, STATUS=1, only consider M1, M2, or M3 of the current quarter)

FirstempY = employment in that FirstY month

If Record Y's first active month in which non-zero employment occurs is:	Set FirstY =	Set FirstempY=
M1 _c	2	M1 _c
M2 _c	3	M2 _c
M3 _c	4	M3 _c
M1 _c = M2 _c = M3 _c = 0	5	0

2. The system will try to match Y's predecessor UI#/RUN to the record in the state system with that UI#/RUN (X)

3. If there is no match between X and Y then do:

If $\text{FirstempY} > \text{PS-UPPER-PARM}$ then flag **edit 161**

4. If there is a match then calculate LastX and LastempX:

LastX = last active month in which there is non-zero employment in record X (emp>0, STATUS=1, only consider M1, M2, and M3 of current quarter and M3 of prior quarter)

LastempX = employment in that Last month

If Record X's last active month in which non-zero employment occurs is:	Set LastX =	Set LastempX =
M3 _p	1	M3 _p
M1 _c	2	M1 _c
M2 _c	3	M2 _c
M3 _c	4	M3 _c
(M1 _c = M2 _c = M3 _c = 0 or STATUS _c ≠ 1) AND (M3 _p = 0 or STATUS _p ≠ 1)	0	0

5. Check the following conditions:

- $\text{UI\#Y} \neq \text{UI\#X}$ or $\text{MEEIY}_c \neq (3 \text{ or } 5)$ or $\text{MEEIX}_c \neq 2$
- $\text{FirstY} \leq \text{LastX}$
- $\text{FirstY} \neq 5$
- $\text{Max}(\text{FirstempY}, \text{LastempX}) > \text{PS-UPPER-PARM}$
- $\text{Min}(\text{FirstempY}, \text{LastempX}) > \text{PS-LOWER-PARM}$

If all the conditions in 5 are true, then flag **edit 160**

6. Check:

- $\text{UI\#Y} \neq \text{UI\#X}$ or $\text{MEEIY}_c \neq (3 \text{ or } 5)$ or $\text{MEEIX}_c \neq 2$
- $\text{FirstY} > (\text{LastX} + 1)$ or $(\text{LastX} = 0 \text{ and } \text{FirstY} \neq 0)$ or $(\text{FirstY} = 5 \text{ and } \text{LastX} \neq 0)$
- $\text{Max}(\text{FirstempY}, \text{LastempX}) > \text{PS-UPPER-PARM}$

If all the conditions in 6 are true, then flag **edit 161**

7. Check:

- $\text{ECCIY}_c > 0$
- $\text{Min}(\text{FirstempY}, \text{LastempX}) \leq \text{PS-LOWER-PARM}$

If either of the above conditions is true, then bypass the rest of the edit
If both of the above conditions are false, then check the following

If $QTR \neq 1$, then check (a) and (b)

If $QTR = 1$, check the following conditions:

- $ARSY = \text{Current Year}$ and $RCY = (46 \text{ or } 50)$
- $ARSX = \text{Current Year}$ and $RCX = (46 \text{ or } 50)$

If either of the above conditions is true, then bypass the rest of the edit

If both of the above conditions are false, check (a) and (b)

(a) Check:

- $STATUSX_C = 1$ and $OWNX_C \neq OWNX_Y$
- $STATUSX_C \neq 1$ and $STATUSX_P = 1$ and $OWNX_P \neq OWNX_Y$

If either condition is true and $\text{Max}(\text{FirstempY}, \text{LastempX}) > PS\text{-}UPPER\text{-}PARM$, then flag **edit 157**

(b) Check:

- $MEEIY_C \neq 2$
- $MEEIY_P \neq 2$
- $MEEIX_C \neq 2$
- $MEEIX_P \neq 2$

If all of the above conditions in (b) are true, then do (i) through (iii):

(i) Check:

- $STATUSX_C = 1$ and $CNTYX_C \neq CNTYY_C$ and $CNTYX_C \neq (995, 996, 998, \text{ or } 999)$
- $STATUSX_C \neq 1$ and $STATUSX_P = 1$ and $CNTYX_P \neq CNTYY_C$ and $CNTYX_P \neq (995, 996, 998, \text{ or } 999)$

If either condition in (i) is true and $\text{Max}(\text{FirstempY}, \text{LastempX}) > PS\text{-}UPPER\text{-}PARM$, then flag **edit 156**

(ii) Check:

- $STATUSX_C = 1$ and $TOWNY_C \neq TOWNX_C$ and $TOWNX_C \neq (995, 996, 998, \text{ or } 999)$ and $STATE = (09, 23, 25, 33, 34, 44, \text{ or } 50)$
- $STATUSX_C \neq 1$ and $STATUSX_P = 1$ and $TOWNY_C \neq TOWNX_P$ and $TOWNX_P \neq (995, 996, 998, \text{ or } 999)$ and $STATE = (09, 23, 25, 33, 34, 44, \text{ or } 50)$

If either condition in (ii) is true and $\text{Max}(\text{FirstempY}, \text{LastempX}) > \text{PS-UPPER-PARM}$, then flag **edit 159**

(iii) Check:

- $\text{STATUSX}_c = 1$ and $\text{NAICSY}_c \neq \text{NAICSX}_c$ and $\text{NAICSX}_c \neq 999999$
- $\text{STATUSX}_c \neq 1$ and $\text{STATUSX}_p = 1$ and $\text{NAICSY}_c \neq \text{NAICSX}_p$ and $\text{NAICSX}_p \neq 999999$

If either condition in (iii) is true and $\text{Max}(\text{FirstempY}, \text{LastempX}) > \text{PS-UPPER-PARM}$, then flag **edit 164**

B. Successor Check

Check:

- $\text{STATUSY}_p = 1$
- Y's Successor UI# \neq blank
- Y's Successor RUN \neq blank

If at least one of the above conditions is false, bypass the rest of the edit

If all the above conditions are true, then do the following steps in the successor check:

1. Calculate LastY and LastempY

LastY = last active month in which there is non-zero employment in record Y (emp>0, STATUS=1, only consider M1, M2, or M3 of the current quarter or M3 of the prior quarter)

LastempY = employment in that LastY month

If Record Y's last active month in which non-zero employment occurs is:	Set LastY =	Set LastempY =
M3 _p	1	M3 _p
M1 _c	2	M1 _c
M2 _c	3	M2 _c
M3 _c	4	M3 _c
(M1 _c = M2 _c = M3 _c = 0 or STATUS _c \neq 1) AND (M3 _p = 0 or STATUS _p \neq 1)	0	0

2. The system will try to match Y's successor UI#/RUN to the record in the microfile with that UI#/RUN (Z)

3. If there is no match between Y and Z then do:

If $\text{STATUSY}_c \neq 1$ and $\text{LastempY} > \text{PS-UPPER-PARM}$ then flag **edit 161**

4. If there is a match then check:

- $STATUSZ_c = 1$
- $STATUSZ_p \neq 1$

If the above conditions in (4) are both true, go to 5
Otherwise, bypass the rest of the edit

5. Calculate FirstZ and FirstempZ

FirstZ = first active month in which there is non-zero employment in record Z
(emp>0, STATUS=1, only consider M1, M2, and M3 of the current quarter)

FirstempZ = employment in that First month

If Record Z's first active month in which non-zero employment occurs is:	Set FirstZ =	Set FirstempZ =
M1 _c	2	M1 _c
M2 _c	3	M2 _c
M3 _c	4	M3 _c
M1 _c = M2 _c = M3 _c = 0 or STATUS _c ≠ 1	5	0

6. Check the following conditions:

- $UI\#Y \neq UI\#Z$ or $MEEIY_c \neq 2$ or $MEEIZ_c \neq (3 \text{ or } 5)$
- $FirstZ \leq LastY$
- $FirstZ \neq 5$
- $Max(FirstempZ, LastempY) > PS-UPPER-PARM$
- $Min(FirstempZ, LastempY) > PS-LOWER-PARM$

If the conditions are true, then flag **edit 160**

7. Check

- $UI\#Y \neq UI\#Z$ or $MEEIY_c \neq 2$ or $MEEIZ_c \neq (3 \text{ or } 5)$
- $FirstZ > (LastY + 1)$ or $(LastY = 0 \text{ and } FirstZ \neq 0)$ or $(FirstZ = 5 \text{ and } LastY \neq 0)$
- $Max(FirstempZ, LastempY) > PS-UPPER-PARM$

If the conditions in (7) are true, then flag **edit 161**

8. Check

- $ECCIZ_c > 0$

- $\text{Min}(\text{FirstempZ}, \text{LastempY}) \leq 25$

If either of the above conditions is true, then bypass the rest of the edit

If both of the above conditions are false, then check the following:

If $QTR \neq 1$, then check (a) and (b)

If $QTR = 1$, check the following conditions:

- $ARSY = \text{Current Year}$ and $RCY = (46 \text{ or } 50)$
- $ARSZ = \text{Current Year}$ and $RCZ = (46 \text{ or } 50)$

If either of the above conditions is true, then bypass the rest of the edit

If both of the above conditions are false, check (a) and (b)

(a) Check

- $STATUSY_c = 1$ and $OWNY_c \neq OWNZ_c$
- $STATUSY_c \neq 1$ and $STATUSY_p = 1$ and $OWNZ_c \neq OWNY_p$

If either condition in (a) is true and $\text{Max}(\text{FirstempZ}, \text{LastempY}) > PS-UPPER-PARM$ then flag **edit 157**

(b) Check:

- $MEEIY_c \neq 2$
- $MEEIY_p \neq 2$
- $MEEIZ_c \neq 2$
- $MEEIZ_p \neq 2$

If all of the above conditions in (b) are true, then do (i) through (iii)

If at least one of the conditions in (b) are false, bypass the rest of the edit

(i) Check:

- $STATUSY_c = 1$ and $CNTYY_c \neq CNTYZ_c$ and $CNTYY_c \neq (995, 996, 998, \text{ or } 999)$
- $STATUSY_c \neq 1$ and $STATUSY_p = 1$ and $CNTYZ_c \neq CNTYY_p$ and $CNTYY_p \neq (995, 996, 998, \text{ or } 999)$

If either condition in (i) is true and $\text{Max}(\text{FirstempZ}, \text{LastempY}) > PS-UPPER-PARM$ then flag **edit 156**

(ii) Check:

- $STATUSY_c = 1$ and $TOWNY_c \neq TOWNZ_c$ and $TOWNY_c \neq (995, 996, 998, \text{ or } 999)$ and $STATE = (09, 23, 25, 33, 34, 44, \text{ or } 50)$
- $STATUSY_c \neq 1$ and $STATUSY_p = 1$ and $TOWNZ_c \neq TOWNY_p$ and $TOWNY_p \neq (995, 996, 998, \text{ or } 999)$ and $STATE = (09, 23, 25, 33, 34, 44, \text{ or } 50)$

If either condition in (ii) is true and $\text{Max}(\text{FirstempZ}, \text{LastempY}) > PS\text{-UPPER-PARM}$, then flag **edit 159**

(iii) Check:

- $STATUSY_c = 1$ and $NAICSY_c \neq NAICSZ_c$ and $NAICSY_c \neq 999999$
- $STATUSY_c \neq 1$ and $STATUSY_p = 1$ and $NAICSY_p \neq NAICSZ_c$ and $NAICSY_p \neq 999999$

If either condition in (iii) is true and $\text{Max}(\text{FirstempZ}, \text{LastempY}) > PS\text{-UPPER-PARM}$, then flag **edit 164**

Editing Parameters/Tolerances:

Parameter	Parameter Name	Length	EXPO PK #	WIN PK #	State Default	BLS Default
<i>PS-UPPER-PARM</i>	Pred/Succ Upper Parm	6	015	042	250	250
<i>PS-LOWER-PARM</i>	Pred/Succ Lower Parm	6	016	043	25	25

Example:

This is an example with many predecessors (Xi) and one successor (Y). The same principles apply when there are many successors.

Record Y has predecessor information, and there is more than one predecessor. Other fields are as follows:

Prior Quarter				
Pred. Record	STATUS in Curr. Qtr.	M1	M2	M3
X1	2	300	311	211
X2	2	0	0	125
X3	2	100	100	125

Current Quarter, Record Y								
ST AT US	ME EI	OWN	NAICS	CNTY	TOWN	M1	M2	M3
1	1	5	561114	013	011	411	412	421

A. Predecessor Check

Check:

- $STATUS_Y_C = 1$
- $STATUS_Y_P \neq 1$ for one or more predecessors (Xi)
- Y's Predecessor UI# \neq blank
- Y's Predecessor RUN \neq blank

All four conditions are true, so go to 1:

1. Calculate FirstY and FirstempY:

$$\text{FirstY} = 2$$

$$\text{FirstempY} = 411$$

2. The system will try to match Y's predecessor UI#/RUN to the record(s) in the microfile with that UI#/RUN (Xi).

There are matches between Xi and Y and the resulting data are as follows:

	Prior Quarter							Current Quarter								
	STATUS	MEEI	OWN	NAICS	CNTY	TOWN	M3	STATUS	MEEI	OWN	NAICS	CNTY	TOWN	M1	M2	M3
X 1	1	1	5	561114	0 2 2	0 1 1	2 1 1	1	1	5	561114	0 2 2	0 1 1	3 0 0	3 0 0	0
X 2	1	1	5	561114	0 2 2	0 1 1	1 2 5	2								
X 3	1	1	5	561114	0 2 2	0 1 1	1 2 5	1	1	5	561114	0 2 2	0 1 1	1 5 5	5	0
Y	2							1	1	5	561114	0 1 3	0 1 1	4 1 1	4 1 2	4 2 1

4. There is a match, so calculate LastX and LastempX:

$$\text{LastX} = 3$$

$$\text{LastempX} = 30 + 5 = 35$$

5. Check the following conditions:

- $\text{UI\#Y} \neq \text{UI\#X}$ or $\text{MEEIY}_C \neq (3 \text{ or } 5)$ or $\text{MEEIX}_C \neq 2$
- $\text{FirstY} \leq \text{LastX}$: $2 \leq 3$:
- $\text{FirstY} \neq 5$: $2 \neq 5$
- $\text{Max}(\text{FirstempY}, \text{LastempX}) > \text{PS-UPPER-PARM}$: $461 > 250$
- $\text{Min}(\text{FirstempY}, \text{LastempX}) > \text{PS-LOWER-PARM}$: $35 > 25$

All of the conditions are false, so record fails **edit 160**.

6. Check:

- $\text{UI\#Y} \neq \text{UI\#X}$ or $\text{MEEIY}_C \neq (3 \text{ or } 5)$ or $\text{MEEIX}_C \neq 2$
- $\text{FirstY} > (\text{LastX} + 1)$ or $(\text{LastX} = 0 \text{ and } \text{FirstY} \neq 0)$ or $(\text{FirstY} = 5 \text{ and } \text{LastX} \neq 0)$
- $\text{Max}(\text{FirstempY}, \text{LastempX}) > \text{PS-UPPER-PARM}$

Not all of the conditions are true, so record does not flag **edit 161**.

7. Check:

- $ECCIIY_C > 0$

- $\text{Min}(\text{FirstempY}, \text{LastempX}) = 35 < 25$

Neither of these conditions is true, so check the following:

If $QTR \neq 1$, then check (a) and (b)

If $QTR = 1$, check the following conditions:

- $ARSY = \text{Current Year}$ and $RCY = (46 \text{ or } 50)$

- $ARSX = \text{Current Year}$ and $RCX = (46 \text{ or } 50)$

These conditions are not true so check (c)

(a) Check:

- $\text{STATUSX}_C = 1$ and $\text{OWNX}_C \neq \text{OWNY}_C$

- $\text{STATUSX}_C \neq 1$ and $\text{STATUSX}_P = 1$ and $\text{OWNX}_P \neq \text{OWNY}_C$

Neither condition is true -- record does not flag **edit 157**

(b) Check:

- $\text{MEEIY}_C \neq 2$

- $\text{MEEIY}_P \neq 2$

- $\text{MEEIX}_C \neq 2$

- $\text{MEEIX}_P \neq 2$

None of the above conditions are true, so do (i) through (iii):

(i) Check:

- $\text{STATUSX}_C = 1$ and $\text{CNTYX}_C \neq \text{CNTYY}_C$ and $\text{CNTYX}_C \neq (995, 996, 998, \text{ or } 999)$

- $\text{STATUSX}_C \neq 1$ and $\text{STATUSX}_P = 1$ and $\text{CNTYX}_P \neq \text{CNTYY}_C$ and $\text{CNTYX}_P \neq (995, 996, 998, \text{ or } 999)$

The first condition in (i) is true and

$\text{Max}(\text{FirstempY}, \text{LastempX}) = 411 > \text{PS-UPPER-PARM}$, so flag **edit 156**

(ii) Check:

- $\text{STATUSX}_C = 1$ and $\text{TOWNY}_C \neq \text{TOWNX}_C$ and $\text{TOWNX}_C \neq (995, 996, 998, \text{ or } 999)$ and $\text{STATE} = (09, 23, 25, 33, 34, 44, \text{ or } 50)$
 - $\text{STATUSX}_C \neq 1$ and $\text{STATUSX}_p = 1$ and $\text{TOWNY}_C \neq \text{TOWNX}_p$ and $\text{TOWNX}_p \neq (995, 996, 998, \text{ or } 999)$ and $\text{STATE} = (09, 23, 25, 33, 34, 44, \text{ or } 50)$
- Neither condition in (ii) is true, so record does not flag **edit 159**

(iii) Check:

- $\text{STATUSX}_C = 1$ and $\text{NAICSY}_C \neq \text{NAICSX}_C$ and $\text{NAICSX}_C \neq 999999$
- $\text{STATUSX}_C \neq 1$ and $\text{STATUSX}_p = 1$ and $\text{NAICSY}_C \neq \text{NAICSX}_p$ and $\text{NAICSX}_p \neq 999999$

Neither condition in (iii) is true, so record does not flag **edit 164**

Record fails edit 156

In this example, record X or Y flags for edit 156—Predecessor-Successor County Code Change Conflict and edit 160—Both Predecessor and Successor Reported.

Level 8 Edit Descriptions – Multi-establishment Edits

Multi-establishment edits review the relationships of each unit or the total of the worksites against the master or parent record. The purposes of these edits are to ensure that:

- The sum of the economic data from sub-units is relatively close to the amount reported for the master record. Edits 171-176, the additivity balance edits, cover this.
- Each multi-establishment family or group has a master record and at least two worksites.
- All members of the family have the same ownership code and EIN.

Additivity/Balance Edits (171-176)

This group of Level 8 edits is used to ensure that the data received electronically or on the Multiple Worksite Report for multi establishment accounts add to the exact amount (or reasonably close to the amount reported) on the Quarterly Contributions Report. Federal government data are bypassed since they do not report QCRs.

Differences may occur when different respondent representatives such as accountants, payroll providers, etc. Complete the MWR or EDI data that are being compared to the QCR. If the data do not add, then the analyst should examine them for the following potential problems:

- Data entry errors
- Inclusion of out-of-state data on the QCR
- Exclusion of new worksites from the MWR
- Mergers or other acquisitions that may be included in one report but not in the other
- Transfers or partial sales that may be reflected in one report but not in the other
- Reporting differences resulting from different people completing the reports

Definitions:

M1	Month One Employment
M2	Month Two Employment
M3	Month Three Employment
TW	Total Wages
TAXW	Taxable Wages
CTB	Contributions Due
Mas	Master Record
Wks	Worksite Records
$\Sigma x_{(wks)}$	Sum of worksite data where $x = M1, M2, M3, TW, TAXW,$ or CTB
Lowx	Lower value between the master record and the sum of the worksites for x where $x = M1, M2, M3, TW, TAXW,$ or CTB
absDx	Absolute difference for data element x where $x = M1, M2, M3, TW, TAXW,$ or CTB between the master record and the sum of the worksite
absPx	Absolute percent difference for data element x where $x = M1, M2, M3, TW, TAXW,$ or CTB between the master record and the sum of the worksite

171 — First Month Employment Additivity/Balance Check

General Description: This Additivity/Balance Check compares data reported in the QCR to data received on either an MWR or via the EDI Center. Minimal differences are allowed. This edit is used for all multi-units except for Federal Government. Federal Government is not edited in this manner, since there are no QCRs to compare against the data on the Report of Federal Employment and Wages (RFEW).

Location: Both BLS & state systems

Edit Level: 8

Priority: A

Level: Micro

Edit Type: Warning

BLS Edit Publ. Criteria: Include, if flagged

Edit Message: *First Month Empl Not in Balance*

Edit Conditions:

Perform this edit when

- The reference quarter equals the current quarter
OR
- The reference quarter equals the prior quarter and the data element changed for either the master record or for at least one of the worksites

Identify all records with an individual multi UI #.

Exclude each individual record if any of the following conditions are met:

- STATUS = 2, 3, or 9
- OWN = 1
- RUN = 00000 record if it's MEEI ≠ 2.
- Worksite unit (RUN > 00000) record if it's MEEI ≠ 3 or 5.

For the multi UI#, sum M1 for all remaining (not bypassed) worksites (MEEI = 3 or 5).

$\Sigma M1_{(wks)} =$ sum of all not excluded M1.

Set $LowM1 = \text{Min}(M1_{(mas)}, \Sigma M1_{(wks)})$.

$absDM1 = |M1_{(MAS)} - \Sigma M1_{(WKS)}|$.

Determine the Edit Level:

Limit = LowM1 x MED-EMPL-BAL-PCT

If Limit < LOW-EMPL-BAL-TOL, go to Level 1.

If LOW-EMPL-BAL-TOL ≤ Limit ≤ HIGH-EMPL-BAL-TOL, go to Level 2.

If Limit > HIGH-EMPL-BAL-TOL, go to Level 3.

Level 1:

If absDM1 > LOW-EMPL-BAL-TOL, flag all units of the multi establishment family with STATUS ≠ 2, 3, or 9. Else pass the edit.

Level 2:

Compute $absPM1 = (absDM1 \div \Sigma M1_{(wks)}) \times 100$

If $absPM1 > MED-EMPL-BAL-PCT$, flag all units of the multi establishment family with STATUS \neq 2, 3, or 9. Else pass the edit.

Level 3:

If $absDM1 > HIGH-EMPL-BAL-TOL$, flag all units of the multi establishment family with STATUS \neq 2, 3, or 9. Else pass the edit.

Example:

RUN	Status Code	First Month Employment
00001	1	50
00002	1	300
00003	1	100
00004	2	0
00005	1	20
00006	1	66
Master—00000	$M1_{(MAS)}$	440
Sum of Worksites	$\Sigma M1_{(WKS)}$	536
LOW-EMP	LowM1	440
Net Difference		-96
Absolute Value	AbsDM1	96
Percent Difference	absPM1	17.9
Limit	$440 \times .10 = 44$	
Employment Level Used:	Middle range: Level is greater than <i>LOW-EMPL-BAL-TOL</i> but less than <i>HIGH-EMPL-BAL-TOL</i>	
Tolerance Used:	<i>MED-EMPL-BAL-PCT</i>	
Flag the Record:	Since the percent difference of 17.9 is greater than the default tolerance of 10, flag the record	

State Parameters and Tolerances:

Parameter	Parameter Name	Length	EXPO PK #	WIN PK #	State Default	BLS Default
<i>LOW-EMPL-BAL-TOL</i>	Small Employment Balance Tolerance	2	032	051	5	10
<i>MED-EMPL-BAL-PCT</i>	Mid-Sized Employment Balance Tolerance	2	033	052	10	50
<i>HIGH-EMPL-BAL-TOL</i>	Large Employment Balance Tolerance	6	034	054	100	100

172 — Second Month Employment Additivity/Balance Check

General Description: This Additivity/Balance Check compares data reported in the QCR to data received on either an MWR or via the EDI Center. Minimal differences are allowed. This edit is used for all multi-units, except for Federal Government. Federal Government is not edited in this manner, since there are no QCRs to compare against the data on the RFEW.

Location: Both BLS and state systems	Level: Micro
Edit Level: 8	Edit Type: Warning
Priority: A	BLS Edit Publ. Criteria: Include, if flagged

Edit Message: *Second Month Empl Not in Balance*

Edit Conditions:

Perform this edit when

- The reference quarter equals the current quarter
OR
- The reference quarter equals the prior quarter and the data element changed for either the master record or for at least one of the worksites

Identify all records with an individual multi UI#.

Exclude each individual record if any of the following conditions are met:

- STATUS = 2, 3, or 9
- OWN = 1
- RUN = 00000 record if it's MEEI ≠ 2.
- Worksite unit (RUN > 00000) record if it's MEEI ≠ 3 or 5.

For the multi account number, sum M2 for all remaining (not bypassed) worksites (MEEI = 3 or 5).

$\Sigma M2_{(wks)} = \text{sum of all not excluded M2.}$

Set $LowM2 = \text{Min}(M2_{(mas)}, \Sigma M2_{(wks)})$.
 $absDM2 = |M2_{(MAS)} - \Sigma M2_{(WKS)}|$.

Determine the Edit Level:

Limit = LowM2 x MED-EMPL-BAL-PCT

If Limit < LOW-EMPL-BAL-TOL, go to Level 1.

If LOW-EMPL-BAL-TOL ≤ Limit ≤ HIGH-EMPL-BAL-TOL, go to Level 2.

If Limit > HIGH-EMPL-BAL-TOL, go to Level 3.

Level 1:

If absDM2 > LOW-EMPL-BAL-TOL, flag all units of the multi establishment family with STATUS ≠ 2, 3, or 9. Else pass the edit.

Level 2:

Compute $\text{absPM2} = (\text{absDM2} \div \Sigma \text{M2}_{(\text{wks})}) \times 100$

If $\text{absPM2} > \text{MED-EMPL-BAL-PCT}$, flag all units of the multi establishment family with $\text{STATUS} \neq 2, 3, \text{ or } 9$. Else pass the edit.

Level 3:

If $\text{absDM2} > \text{HIGH-EMPL-BAL-TOL}$, flag all units of the multi establishment family with $\text{STATUS} \neq 2, 3, \text{ or } 9$. Else pass the edit.

Editing Parameters/Tolerances:

Parameter	Parameter Name	Length	EXPO PK #	WIN PK #	State Default	BLS Default
<i>LOW-EMPL-BAL-TOL</i>	Small Employment Balance Tolerance	2	032	051	5	10
<i>MED-EMPL-BAL-PCT</i>	Mid-Sized Employment Balance Tolerance	2	033	052	10	50
<i>HIGH-EMPL-BAL-TOL</i>	Large Employment Balance Tolerance	6	034	054	100	100

173 — Third Month Employment Additivity/Balance Check

General Description: This Additivity/Balance Check compares data reported in the QCR to data received on either an MWR or via the EDI Center. Minimal differences are allowed. This edit is used for all multi-units, except for Federal Government. Federal Government is not edited in this manner, since there are no QCRs to compare against the data on the RFEW.

Location: Both BLS and state systems

Edit Level: 8

Priority: A

Level: Micro

Edit Type: Warning

BLS Edit Publ. Criteria: Include, if flagged

Edit Message: *Third Month Empl Not in Balance*

Edit Conditions:

Perform this edit when

- The reference quarter equals the current quarter
OR
- The reference quarter equals the prior quarter and the data element changed for either the master record or for at least one of the worksites

Identify all records with an individual multi UI account number.

Exclude each individual record if any of the following conditions are met:

- $\text{STATUS} = 2, 3, \text{ or } 9$
- $\text{OWN} = 1$

- RUN = 00000 record if it's MEEI \neq 2.
- Worksite unit (RUN > 00000) record if it's MEEI \neq 3 or 5.

For the multi UI#, sum M3 for all remaining (not bypassed) worksites (MEEI = 3 or 5).

$\Sigma M3_{(wks)}$ = sum of all not excluded M3.

Set LowM3 = $\text{Min}(M3_{(mas)}, \Sigma M3_{(wks)})$.

$\text{absDM3} = |M3_{(MAS)} - \Sigma M3_{(WKS)}|$.

Determine the Edit Level:

Limit = LowM3 x MED-EMPL-BAL-PCT

If Limit < LOW-EMPL-BAL-TOL, go to Level 1.

If LOW-EMPL-BAL-TOL \leq Limit \leq HIGH -EMPL-BAL-TOL, go to Level 2.

If Limit > HIGH -EMPL-BAL-TOL, go to Level 3.

Level 1:

If $\text{absDM3} > \text{LOW-EMPL-BAL-TOL}$, flag all units of the multi establishment family with STATUS \neq 2, 3, or 9. Else pass the edit.

Level 2:

Compute $\text{absPM3} = (\text{absDM3} \div \Sigma M3_{(wks)}) \times 100$

If $\text{absPM3} > \text{MED-EMPL-BAL-PCT}$, flag all units of the multi establishment family with STATUS \neq 2, 3, or 9. Else pass the edit.

Level 3:

If $\text{absDM3} > \text{HIGH-EMPL-BAL-TOL}$, flag all units of the multi establishment family with STATUS \neq 2, 3, or 9. Else pass the edit.

Editing Parameters/Tolerances:

Parameter	Parameter Name	Length	EXPO PK #	WIN PK #	State Default	BLS Defau lt
<i>LOW-EMPL-BAL-TOL</i>	Small Employment Balance Tolerance	2	032	051	5	10
<i>MED-EMPL-BAL-PCT</i>	Mid-Sized Employment Balance Tolerance	2	033	052	10	50
<i>HIGH-EMPL-BAL-TOL</i>	Large Employment Balance Tolerance	6	034	054	100	100

174 — Total Wages Additivity/Balance Check

General Description: This Additivity/Balance Check compares data reported in the QCR to data received on either an MWR or via the EDI Center. Minimal differences are allowed. This edit is used for all multi-units, except for Federal Government. Federal Government is not edited in this manner, since there are no QCRs to compare against the data on the RFEW.

Location: Both BLS and state systems

Edit Level: 8

Priority: A

Level: Micro

Edit Type: Warning

BLS Edit Publ. Criteria: Include, if flagged

Edit Message: *Total Wages Not in Balance*

Edit Conditions:

Perform this edit when

- The reference quarter equals the current quarter
OR
- The reference quarter equals the prior quarter and the data element changed for either the master record or for at least one of the worksites

Identify all records with an individual multi UI#.

Exclude each individual record if any of the following conditions are met:

- STATUS = 2, 3, or 9
- OWN = 1
- RUN = 00000 record if it's MEEI ≠ 2.
- Worksite unit (RUN > 00000) record if it's MEEI ≠ 3 or 5.

For the multi UI#, sum TQW for all remaining (not bypassed) worksites (MEEI = 3 or 5).
 $\Sigma TQW_{(wks)} = \text{sum of all not excluded TW.}$

Set $LowTW = \text{Min}(TW_{(mas)}, \Sigma TW_{(wks)}).$

$$\text{AbsDTW} = |\text{TW}_{(\text{MAS})} - \Sigma\text{TW}_{(\text{WKS})}|.$$

Determine the Edit Level:

$$\text{Limit} = \text{LowTW} \times \text{MED-WAGE-BAL-MIL}$$

If $\text{Limit} < \text{LOW-WAGE-BAL-TOL}$, go to Level 1.

If $\text{Limit} \geq \text{LOW-WAGE-BAL-TOL}$ but $\text{Limit} \leq \text{HIGH-WAGE-BAL-TOL}$, go to Level 2.

If $\text{Limit} > \text{HIGH-WAGE-BAL-TOL}$, go to Level 3.

Level 1:

If $\text{AbsDTW} > \text{LOW-WAGE-BAL-TOL}$, flag all units of the multi establishment family with $\text{STATUS} \neq 2, 3, \text{ or } 9$. Else pass the edit.

Level 2:

$$\text{Compute absPTW} = (\text{AbsDTW} \div \Sigma\text{TW}_{(\text{WKS})}) \times 100$$

If $\text{absPTW} > \text{MED-WAGE-BAL-MIL}$, flag all units of the multi establishment family with $\text{STATUS} \neq 2, 3, \text{ or } 9$. Else pass the edit.

Level 3:

If $\text{absDTW} > \text{HIGH-WAGE-BAL-TOL}$, flag all units of the multi establishment family with $\text{STATUS} \neq 2, 3, \text{ or } 9$. Else pass the edit.

Example:

RUN	Status Code	Total Wages
00001	1	10,000
00002	1	30,000
00003	1	7,500
00004	2	0
00005	1	22,000
00006	1	5,500
Master—00000	$\text{TW}_{(\text{mas})}$	65,000
Sum of Worksites	$\Sigma\text{TW}_{(\text{WKS})}$	75,000
LOW-WAGE	LowTW	65,000
Net Difference		-10,000
Absolute Value	absDTW	10,000
Percent Difference	absPTW	13.3
Limit	$65,000 \times 1\% = 650$	
Wage Level Used:	middle range greater than <i>LOW-WAGE-BAL-TOL</i> but less than <i>HIGH-WAGE-BAL-TOL</i> —(650 is between 500 and 10,000)	
Tolerance Used:	<i>MED-WAGE-BAL-MIL</i>	
Flag the Record:	Since the percent difference of 13.3 is greater than the default tolerance of 1, flag the record	

Editing Parameters/Tolerances:

Parameter	Parameter Name	Length	EXPO PK #	WIN PK #	State Default	BLS Default
LOW-WAGE- BAL-TOL	Small Wage Balance Tolerance	6	037	056	500	5,000
MED-WAGE- BAL-MIL	Medium Wage Mill Balance Tolerance	2	038	057	1% (expressed as 10 in EXPO & 1 in WIN)	10% (expressed as 10)
HIGH-WAGE- TOL	Large Wage Balance Tolerance	6	039	059	10,000	100,000

175 — Taxable Wages Additivity/Balance Check

General Description: This Additivity/Balance Check compares data reported on the master record to data reported on multi worksites. Minimal differences are allowed. This edit is used for all multi-units, except for Federal Government. Federal Government records should never report Taxable Wages or Contributions.

Location: State only

Edit Level: 8

Priority: A

Level: Micro

Edit Type: Warning, if used

BLS Edit Publ. Criteria: Not Applicable

Edit Message: *Taxable Wages Not in Balance*Edit Conditions:

Perform this edit when

- The reference quarter equals the current quarter
- OR
- The reference quarter equals the prior quarter and the data element changed for either the master record or for at least one of the worksites

Identify all records with an individual multi UI#.

Exclude each individual record if any of the following conditions are met:

- STATUS = 2, 3, or 9
- OWN = 1
- RUN = 00000 record if it's MEEI ≠ 2.
- Worksite unit (RUN > 00000) record if it's MEEI ≠ 3 or 5.

For multi UI#, sum TAXW for all remaining (not bypassed) worksites (MEEI = 3 or 5).

 $\Sigma\text{TAXW}_{(\text{wks})}$ = sum of all not excluded TAXW.

Set $\text{LowTAXW} = \text{Min}(\text{TAXW}_{(\text{mas})}, \Sigma\text{TAXW}_{(\text{wks})})$.

$\text{absDTAXW} = |\text{TAXW}_{(\text{MAS})} - \Sigma\text{TAXW}_{(\text{WKS})}|$.

Determine the Edit Level:

$$\text{Limit} = \text{LowTAXW} \times \text{MED-TAXWAGE-BAL-MIL}$$

If Limit < LOW-TAXWAGE-BAL-TOL, go to Level 1.

If Limit ≥ LOW-TAXWAGE-BAL-TOL but Limit ≤ HIGH-TAXWAGE-BAL-TOL, go to Level 2.

If Limit > HIGH-TAXWAGE-BAL-TOL, go to Level 3.

Level 1:

If AbsDTAXW > LOW-TAXWAGE-BAL-TOL, flag all units of the multi establishment family with STATUS ≠ 2, 3, or 9. Else pass the edit.

Level 2:

$$\text{Compute absPTAXW} = (\text{AbsDTAXW} \div \Sigma \text{TAXW}_{(\text{wks})}) \times 100$$

If absPTW > MED-TAXWAGE-BAL-MIL, flag all units of the multi establishment family with STATUS ≠ 2, 3, or 9. Else pass the edit.

Level 3:

If absDTAXW > HIGH-TAXWAGE-BAL-TOL, flag all units of the multi establishment family with STATUS ≠ 2, 3, or 9. Else pass the edit.

Editing Parameters/Tolerances:

Parameter	Parameter Name	Length	EXPO PK #	WIN PK #	State Default	BLS Default
LOW-TAXWAGE-BAL-TOL	Low Wage Balance Tolerance	6	037	056	500	N/A
MED-TAXWAGE-BAL-MIL	Medium Wage Mill Balance Tolerance	2	038	057	1% (expressed as 10 in EXPO and 1 in WIN)	N/A
HIGH-TAXWAGE-TOL	Large Wage Balance Tolerance	6	039	059	10,000	N/A

176 — Contributions Additivity/Balance Check

General Description: This Additivity/Balance Check compares data reported on the master record to data reported on multi worksites. Minimal differences are allowed. This edit is used for all multi-units, except for Federal Government. Federal Government records should never report Taxable Wages or Contributions.

Location: State only

Edit Level: 8

Priority: A

Level: Micro

Edit Type: Warning, if used

BLS Edit Publ. Criteria: Not Applicable

Edit Message: *Contributions Not in Balance*

Edit Conditions:

Perform this edit when either condition is true

- The reference quarter equals the current quarter
- OR
- The reference quarter equals the prior quarter and the data element changed for either the master record or for at least one of the worksites

Identify all records with an individual multi UI#.

Exclude each individual record if any of the following conditions are met:

- Status = 2, 3, or 9
- Own = 1
- RUN = 00000 record if it's MEEI \neq 2.
- Worksite unit (RUN > 00000) record if it's MEEI \neq 3 or 5.

For multi UI#, sum CTB for all remaining (not bypassed) worksites (MEEI = 3 or 5).

- $\Sigma\text{CTB}(\text{wks})$ = sum of all not excluded CTB.
- Set $\text{LowCTB} = \text{Min}(\text{CTB}(\text{mas}), \Sigma\text{CTB}(\text{wks}))$.
- $\text{absDCTB} = |\text{CTB}(\text{mas}) - \Sigma\text{CTB}(\text{wks})|$.

Determine the Edit Level:

Limit = $\text{LowCTB} \times \text{MED-TAXWAGE-BAL-MIL}$

If $\text{Limit} < \text{LOW-TAXWAGE-BAL-TOL}$, go to Level 1.

If $\text{Limit} \geq \text{LOW-TAXWAGE-BAL-TOL}$ but $\text{Limit} \leq \text{HIGH-TAXWAGE-BAL-TOL}$, go to Level 2.

If $\text{Limit} > \text{HIGH-TAXWAGE-BAL-TOL}$, go to Level 3.

Level 1:

If $\text{AbsDCTB} > \text{LOW-TAXWAGE-BAL-TOL} \times \text{CONTRIB-BAL-PCT}$, flag all units of the multi establishment family with STATUS \neq 2, 3, or 9. Else pass the edit.

Level 2:

Compute $\text{absPCTB} = (\text{AbsDCTB} \div \Sigma\text{CTB}(\text{wks})) \times 100$

If $\text{absPCTB} > \text{MED-TAXWAGE-BAL-MIL} \times \text{CONTRIB-BAL-PCT}$, flag all units of the multi establishment family with STATUS \neq 2, 3, or 9. Else pass the edit.

Level 3:

If $\text{absDCTB} > \text{HIGH-TAXWAGE-BAL-TOL} \times \text{CONTRIB-BAL-PCT}$, flag all units of the multi establishment family with STATUS \neq 2, 3, or 9. Else pass the edit.

Editing Parameters/Tolerances:

Parameter	Parameter Name	Length	EXPO PK #	WIN PK #	State Default	BLS Default
<i>LOW-TAXWAGE-BAL-TOL</i>	Low Wage Balance Tolerance	6	037	056	500	N/A
<i>MED-TAXWAGE-BAL-MIL</i>	Medium Wage Mill Balance Tolerance	2	038	057	1% (expressed as 10 in EXPO and 1 in WIN)	N/A
<i>HIGH-TAXWAGE-TOL</i>	Large Wage Balance Tolerance	6	039	059	10,000	N/A
<i>CONTRIB-BAL-PCT</i>	Contributions Percentage Applied To Balance	2	040	067	10	N/A

178 — Master Without Multiple Worksites Check

General Description: The Master Without Multiple Worksites edit checks for worksites when a master record exists. If an active unit is determined to be a master record with an MEEI code of 2, then there must be at least 2 corresponding active worksite records for the same UI Account Number in the same year and quarter. This error may occur when

- An employer account is being set up as a multi-establishment reporter and the RUN = 00000 record's MEEI code is not changed to 2, or the worksites are not set up, or the worksites have STATUS = 9.
- When a multi-establishment reporter is reduced to only a single worksite. In these cases, the master should be converted to a single unit (MEEI = 1, 4, or 6) comprised of the data for the worksite. The remaining worksite is inactivated.

Location: Both BLS and state Systems

Edit Level: 8

Priority: A

Level: Micro

Edit Type: Invalid

BLS Edit Publ. Criteria: Include, if flagged

Edit Message: *Master Without Multiple Worksites*

Edit Conditions:

Examine all active records (STATUS = 1) that have the same UI#.

Flag if both conditions are met

- A unit has RUN = 00000 and MEEI = 2, and
- Less than two units have active RUN > 00000 with MEEI codes = 3 or 5.

179 — Worksites Without Master Account Check

General Description: The Worksites Without Master Account edit checks for a master record when worksites exist. If a worksite record is active, then the unit must have a corresponding active master record. This situation frequently occurs

- When a single establishment is broken out into multiple establishments and the single is dropped from the file or inactivated, or
- When a multi account is sold to another account. The data for the master record is moved to the new account but the worksites are not inactivated or properly transferred.

Location: Both BLS and state systems

Level: Micro

Edit Level: 8

Edit Type: invalid

Priority: A

BLS Edit Publ. Criteria: Include, if flagged

Edit Message: *Worksite Missing Master*

Edit Conditions:

Examine all active records (STATUS = 1) that have the same UI#.

Flag if both conditions are met

- None of the units have a RUN = 00000 with an MEEI = 2, and
- At least one unit has a RUN > 00000 or is coded MEEI = 3 or 5.

180 — Single Has Active Worksites Check

General Description: The Single Has Active Worksites edit checks for single units with worksites that exist for the same UI Account Number. This error frequently occurs

- When an employer account is being set up as a multi-establishment reporter and the RUN = 00000 record's MEEI code is not changed to 2, or
- When a multi-establishment report is being collapsed and the RUN = 00000 record is given an MEEI code of 1, 4, or 6 but the worksites are not inactivated.

Location: Both BLS and state systems

Level: Micro

Edit Level: 8

Edit Type: Invalid

Priority: A

BLS Edit Publ. Criteria: Include, if flagged

Edit Message: *Single Account/Active Worksites*

Edit Conditions:

Examine all active records (STATUS = 1) that have the same UI#.

Flag if both conditions are met

- At least one unit has a RUN = 00000 and is coded MEEI = 1, 4, or 6, and
- At least one other unit is coded as a sub-unit (MEEI = 3 or 5 or RUN > 00000)

181 — Master/Worksite Owner Code Check

General Description: The Master/Worksite Ownership Code edit checks for ownership discrepancies between master and worksites. A multi-establishment master record and its worksites should all have the same Ownership Code. A professional employee organization (PEO) or employee leasing firm may report data on a MWR for units in multiple ownerships (e.g., a local government hospital and a private sector factory). If they are all reported using the PEO's UI Account Number, they should all be reported as private sector (ownership 5) units since the PEO is in the private sector.

Location: Both BLS and state systems

Level: Micro

Edit Level: 8

Edit Type: Invalid

Priority: A

BLS Edit Publ. Criteria: Include, if flagged

Edit Message: *Worksite Ownership Code Differs from Master*

Edit Conditions:

Compare all active records (STATUS = 1) that have the same UI#.

Flag if not all records have the same OWN.

182 — Master/Worksite EIN Check

General Description: The Master/Worksite EIN edit checks for EIN discrepancies between master and sub-units. A multi-establishment master record and its worksites should not have more than one EIN. EIN must be the same for master and worksites with the same UI Account Number. In some cases where partial or complete mergers occur, the predecessor's EIN may be inadvertently retained on some of the worksites and will cause this edit to flag the account.

Location: Both BLS and state systems

Level: Micro

Edit Level: 8

Edit Type: Invalid

Priority: A

BLS Edit Publ. Criteria: Include, if flagged

Edit Message: *Worksite EIN Differs From Master*

Edit Conditions:

Bypass if OWN = 1

Compare all active records (STATUS = 1) that have the same UI#.

Flag if not all records have the same EIN.

System Action: If the EIN of the worksite is missing or zero-filled and the master record EIN is a valid non-zero value, then the state systems will copy the master record EIN to the worksite.

185 — Master/Worksite Indian Tribal Check

General Description: The Master/Worksite Indian Tribal Code edit checks for special indicator code T discrepancies between master and worksites. A multi-establishment master record and its worksites should all have the T indicator if truly Indian Tribal Council records.

Location: Both BLS and state systems	Level: Micro
Edit Level: 8	Edit Type: Invalid
Priority: A	BLS Edit Publ. Criteria: Include, if flagged

Edit Message: *Inconsistent Indian Tribal Codes within the Multi Account*

Edit Conditions:

Compare all active records (STATUS = 1) that have the same UI#.

Flag if not all records have the same SPECIAL INDICATOR = T.

Level 9 Edit Descriptions – Wage Record Edits

Wage record edits are a tool which can be used in conjunction with the employment and wage edits to help determine if the employment or wage change is supported by data changes in wage record data. These edits should only be run if the state can obtain and load automated files of wage record data.

Note: States using these editing tools should ensure that data for their wage records include all UI-covered employees and that wage data on wage records include adequate dollar field length for the total wage amount.

193 — First Month Employment/Wage Record Comparison

General Description: The Wage Record Count is a 6-digit numeric, unduplicated tally of all employees' wage record listed on the QCR. The month-to-month employment found in the Micro extract file should be less than or equal to wage record count. The validation of this relationship is conducted using a percentage tolerance (tol).

Location: Both BLS and state systems	Level: Micro
Edit Level: 9	Edit Type: Warning
Priority: C	BLS Edit Publ. Criteria: Include, if flagged

Edit Message: *First Month Empl > Wage Record Count*

Edit Conditions:

Bypass if any of the following conditions are met:

- STATUS = 2 or 9
- WAGE RECORD WAGE is not numeric
- WAGE RECORD WAGE = 0
- MEEI = 3 or 5
- Wage records not reported or not available
- COVERAGE = 1, 3, 8, or 9
- OWN = 1
- $AME_c < WAGE-REC-EDIT-AME$.

Flag if both conditions are met

- $AME_c > WAGE-REC-EDIT-AME$ and
- $M1_c - WAGE\ RECORD\ COUNT > (M1_c \times EMPL-GT-WRC-PCT)/100$.

Editing Parameters/Tolerances:

Parameter	Parameter Name	Length	EXPO PK #	WIN PK #	State Default	BLS Default
<i>WAGE-REC-EDIT-AME</i>	Maximum AME For Wage Record Edits Bypass	6	046	062	50	50
<i>EMPL-GT-WRC-PCT</i>	Limit For Employment > Wage Record Count (Percent)	2	047	063	10	10

Note: States using these editing tools should ensure that data for their wage records include all UI-covered employees and that wage data on wage records include adequate dollar length for the total wage amount.

System Actions: (1) Display the UI account of the possible predecessor either in the error message, on the listing output, or on the on-line edit screen. Allow state to run these edits separately or at a different time than the rest of the edits since they are dependent upon access to wage record information which may be available later in the edit cycle. (2) If wage records are not available, then the edit is bypassed.

194 — Second Month Employment/Wage Record Comparison

General Description: The Wage Record Count is a 6-digit numeric, unduplicated tally of all employees' wage record listed on the QCR. The month-to-month employment found in the Micro extract file should be less than or equal to the wage record count. The validation of this relationship is conducted using a percentage tolerance.

Location: Both BLS and state systems
 Edit Level: 9
 Priority: C

Level: Micro
 Edit Type: Warning
 BLS Edit Publ. Criteria: Include, if flagged

Edit Message: *Second Month Empl > Wage Record Count*Edit Conditions:

Bypass if any of the following conditions are met:

- STATUS = 2 or 9
- WAGE RECORD WAGE is not numeric
- WAGE RECORD WAGE = 0
- MEEI = 3 or 5
- Wage records not reported or not available
- COVERAGE = 1, 3, 8, or 9
- OWN = 1
- AME_c < WAGE-REC-EDIT-AME.

Flag if both conditions are met

- AME_c > WAGE-REC-EDIT-AME and
- M2_c - WAGE RECORD COUNT > (M2_c x EMPL-GT-WRC-PCT)/100.

Editing Parameters/Tolerances:

Parameter	Parameter Name	Length	EXPO PK #	WIN PK #	State Default	BLS Default
WAGE-REC-EDIT-AME	Maximum AME For Wage Record Edits Bypass	6	046	062	50	50
EMPL-GT-WRC-PCT	Limit For Employment > Wage Record Count (Percent)	2	047	063	10	10

Note: States using these editing tools should ensure that data for their wage records include all UI-covered employees and that wage data on wage records include adequate dollar length for the total wage amount.

System Actions: (1) Display the UI account of the possible predecessor either in the error message, on the listing output, or on the on-line edit screen. Allow state to run these edits separately or at a different time than the rest of the edits since they are dependent upon access to wage record information which may be available later in the edit cycle. (2) If wage records are not available, then the edit is bypassed.

195 — Third Month Employment/Wage Record Comparison

General Description: The Wage Record Count is a 6-digit numeric, unduplicated tally of all employees' wage record listed on the QCR. The month-to-month employment found in the Micro extract file should be less than or equal to the wage record count. The validation of this relationship is conducted using a percentage tolerance.

Location: Both BLS and state systems

Level: Micro

Edit Level: 9
Priority: C

Edit Type: Warning
BLS Edit Publ. Criteria: Include, if
flagged

Edit Message: *Third Month Empl > Wage Record Count*

Edit Conditions:

Bypass if any of the following conditions are met:

- STATUS = 2 or 9
- WAGE RECORD WAGE is not numeric
- WAGE R
- ECORD WAGE = 0
- MEEI = 3 or 5
- Wage records not reported or not available
- COVERAGE = 1, 3, 8, or 9
- OWN = 1
- $AME_C < WAGE-REC-EDIT-AME$.

Flag if both conditions are met

- $AME_C > WAGE-REC-EDIT-AME$ and
- $M3_C - WAGE\ RECORD\ COUNT > (M3_C \times EMPL-GT-WRC-PCT)/100$.

Editing Parameters/Tolerances:

Parameter	Parameter Name	Length	EXPO PK #	WIN PK #	State Default	BLS Default
<i>WAGE-REC-EDIT-AME</i>	Maximum AME For Wage Record Edits Bypass	6	046	062	50	50
<i>EMPL-GT-WRC-PCT</i>	Limit For Employment > Wage Record Count (Percent)	2	047	063	10	10

Note: States using these editing tools should ensure that data for their wage records include all UI-covered employees and that wage data on wage records include adequate dollar length for the total wage amount.

System Actions: (1) Display the UI account of the possible predecessor either in the error message, on the listing output, or on the on-line edit screen. Allow state to run these edits separately or at a different time than the rest of the edits since they are dependent upon access to wage record information which may be available later in the edit cycle. (2) If wage records are not available, then the edit is bypassed.

196 — Wage Record Check

General Description: This edit ensures that employment does not equal the number of wage records. Wage record edits are to be run in the state if the data are accessible. They should be run either with the other edits or on a lagged basis (when most of the information would be available), or periodically to capture potential reporting problems. These edits help to identify reporting problems that are frequently missed in the other systems because the data normally do not fluctuate from month to month or over time. Where appropriate, letters should be generated to send to the employer to resolve long standing reporting problems.

Location: Both BLS and state systems

Edit Level: 9

Priority: C

Level: Micro

Edit Type: Warning

BLS Edit Publ. Criteria: Include, if
flaggedEdit Message: *All Months Empl = Wage Record Count*Edit Conditions:

Bypass if any of the following conditions are met:

- STATUS = 2 or 9
- WAGE RECORD WAGE is not numeric
- WAGE RECORD WAGE = 0
- MEEI = 3 or 5
- Wage records not reported or not available
- COVERAGE = 1, 3, 8, or 9
- OWN = 1
- $AME_C < WAGE-REC-EDIT-AME$.

Flag if all conditions are met

- $AME_C > WAGE-REC-EDIT-AME$ and
- $M1_C = M2_C = M3_C = WAGE\ RECORD\ COUNT$, where M1-IND_C nor M2-IND_C nor M3-IND_C = "E" or "H".

Editing Parameters/Tolerances:

Parameter	Parameter Name	Length	EXPO PK #	WIN PK #	State Default	BLS Default
<i>WAGE-REC-EDIT-AME</i>	Maximum AME For Wage Record Edits Bypass	6	046	062	50	50

Note: States using these editing tools should ensure that data for their wage records include all UI-covered employees and that wage data on wage records include adequate dollar length for the total wage amount.

System Actions: (1) Display the UI account of the possible predecessor either in the error message, on the listing output, or on the on-line edit screen. Allow state to run these edits separately or at a different time than the rest of the edits since they are dependent upon access to wage record information which may be available later in the edit cycle. (2) If wage records are not available, then the edit is bypassed.

197 — Total Wages/Wage Record Wages Comparison Check

General Description: Wage record edits are to be run in the state if the data are accessible. They should be run either with the other edits, or on a lagged basis (when most of the information would be available), or periodically to capture potential reporting problems. These edits help to identify reporting problems that are frequently missed in the other systems because the data normally do not fluctuate from month to month or over time. Where appropriate, letters should be generated to send to the employer to resolve long standing reporting problems.

Location: Both BLS and state systems	Level: Micro
Edit Level: 9	Edit Type: Warning
Priority: C	BLS Edit Publ. Criteria: Include, if flagged

Edit Message: *Total Wages Vary from Wage Records*

Edit Conditions:

Bypass if any of the following conditions are met:

- STATUS = 2 or 9
- WAGE RECORD WAGE is not numeric
- WAGE RECORD WAGE = 0
- MEEI = 3 or 5
- Wage records not reported or not available
- COVERAGE = 1, 3, 8, or 9
- OWN = 1
- $AME_c < WAGE-REC-WAGE-AME$.

Flag if both conditions are met

- $AME_c > WAGE-REC-WAGE-AME$ and
- $|TW_c - WAGE\ RECORD\ WAGES| > (WAGE-GT-WRW-PCT \times TW_c)$.

Editing Parameters/Tolerances:

Parameter	Parameter Name	Length	EXPO PK #	WIN PK #	State Default	BLS Default
WAGE-REC-WAGE-AME	Maximum AME For Wage Record Wage Edits Bypass	6	049	065	100	100
WAGE-GT-WRW-PCT	Limit For Total Wages > Wage Record Wages %	2	050	066	20	20

Note: States using these editing tools should ensure that data for their wage records include all UI-covered employees and that wage data on wage records include adequate dollar length for the total wage amount.

System Actions: (1) Display the UI account of the possible predecessor either in the error message, on the listing output, or on the on-line edit screen. Allow state to run these edits separately or at a different time than the rest of the edits since they are dependent upon access to wage record information which may be available later in the edit cycle. (2) If wage records are not available, then the edit is bypassed.

198 — Divergent Employment Trend Check

General Description: This edit compares the employment movement between the current and prior quarter against the wage record count movement between the same time periods. It would be reasonable to assume that both should be moving somewhat similarly.

Location: State only
Edit Level: 9
Priority: C

Level: Micro
Edit Type: Warning
BLS Edit Publ. Criteria: Include, if flagged

Edit Message: Divergent Employment Trends (empl vs wage records)

Edit Conditions:

Bypass if any of the following conditions are met:

- STATUS = 2, 3, or 9
- WAGE RECORD WAGE is not numeric
- MEEI = 3 or 5
- Wage records not reported or not available
- COVERAGE = 1, 3, 8, or 9
- OWN = 1
- $AME_c < WAGE-REC-EDIT-AME$.

Flag if all conditions are met

- $STATUS_c \neq 2, 3, \text{ or } 9$
- RUN = 00000 (MEEI = 1, 2, 4, or 6)
- $AME_c > WAGE-REC-EDIT-AME$
- WAGE RECORD COUNT_c > 0
- WAGE RECORD COUNT_p > 0
- $|(AME_c - AME_p) - (WAGE\ RECORD\ COUNT_c - WAGE\ RECORD\ COUNT_p)| > AME_c \times PPS-EMP\%$

Editing Parameters/Tolerances:

Parameter	Parameter Name	Length	EXPO PK #	WIN PK #	State Default	BLS Default
WAGE-REC-EDIT- AME	Maximum AME For Wage Record Edits Bypass	6	046	062	50	50
PPS-EMP%	Potential Predecessor /Successor Employment Percentage	6	087	N/A	75	75

Note: States using these editing tools should ensure that data for their wage records include all UI-covered employees and that wage data on wage records include adequate dollar length for the total wage amount.

System Actions: (1) Display the UI account of the possible predecessor either in the error message, on the listing output, or on the on-line edit screen. Allow state to run these edits separately or at a different time than the rest of the edits since they are dependent upon access to wage record information which may be available later in the edit cycle. (2) If wage records are not available, then the edit is bypassed.

Appendix G – Edit Codes and Messages

The following table contains summary information on edits by edit code. Edit messages may appear on some listings or screens in a slightly abbreviated or varied form. The edit codes are listed in numerical order.

The table identifies whether edits are performed at the micro level, the macro level, or both. Most of the edits listed below are performed at the micro level only. Edits 089, 090, 091, 092, 093, 094, 126, 127, 130, 131, 136, 137, and 138 are performed at both the micro and macro levels, while edits 134 and 135 are macro level edits only. Edits 089, 090, 136, 137, and 138 only exist in the WIN system (the edits are performed in EXPO and the national office system, but they are coded as 091 or 126). Edits 001 and 006 are performed only in the national office system. Edits 047, 053, 054, 118, 175, and 176 are performed only in the WIN and EXPO State systems.

The table also identifies the priority of the edits according to the ABC list. The column Pub Ex identifies edits that cause a record to be excluded from BLS publication. Edit conditions and formulas are described in detail in Appendix F. The ABC list is described in depth in Section 13.3.3.

Edit Code	ABC	Pub Ex	Mic, Mac or Both	Edit Message
<i>Level 1 – Pre-edits</i>				
001-I	C		mic	BLS Only: Invalid Transaction Code
002-I	A		mic	Invalid Unemployment Insurance (UI) Account Number
003-I	A		mic	Invalid Reporting Unit Number
004-I	A		mic	Invalid Reference Year
005-I	A		mic	Invalid Reference Quarter
006-I	A		mic	BLS Only: Invalid State Code
<i>Level 2 – Key Field edits</i>				
010-I	A	Y	mic	Invalid NAICS Code
012-I	A	Y	mic	Invalid Ownership Code
013-I	A	Y	mic	Invalid County Code
016-I	A	Y	mic	NAICS & Ownership Inconsistent
<i>Level 3 – Date and Status Code Edits</i>				
021-I	C		mic	Invalid Initial Liability Date Format
022-I	C		mic	Invalid End of Liability (EOL) Date Format
023-I	C		mic	Invalid Setup Date Format
024-I	C		mic	Reactivation Date Invalid or Earlier than Liability Date

Edit Code	ABC	Pub Ex	Mic, Mac or Both	Edit Message
025-I	A	Y	mic	Invalid Status Code
<i>Level 4 – Remaining Invalid Error Edits</i>				
031-I	A	Y	mic	Invalid First Month Employment
032-I	A	Y	mic	Invalid Second Month Employment
033-I	A	Y	mic	Invalid Third Month Employment
034-I	A	Y	mic	Invalid Total Wages
035-I	A	Y	mic	Invalid Taxable Wages
036-I	A	Y	mic	Invalid Contributions
039-I	A	Y	mic	Invalid Type of Coverage
040-I	A	Y	mic	Invalid Multi-establishment Employer Indicator (MEEI) Code
043-I	B		mic	Invalid Predecessor SESA ID
044-I	B		mic	Invalid Successor SESA ID
045-I	A		mic	Invalid Federal EI Number
046-I	B		mic	Invalid Annual Refiling Survey (ARS) Response Code/Year
047-I	C		mic	State Only: Invalid Tax Rate - Beyond Minimum/Maximum Range
048-I	C		mic	Invalid Comment Code
049-I	C		mic	Invalid First Month Employment Indicator
050-I	C		mic	Invalid Second Month Employment Indicator
051-I	C		mic	Invalid Third Month Employment Indicator
052-I	C		mic	Invalid Total Wages Indicator
053-I	C		mic	State Only: Invalid Taxable Wages Indicator
054-I	C		mic	State Only: Invalid Contributions Due Indicator
056-I	A	Y	mic	Inconsistent Ownership/Type of Coverage
057-I	A	Y	mic	Taxable Wages on Federal Record
058-I	A	Y	mic	Contributions on Federal Record
059-I	A	Y	mic	Taxable Wages > 0 for Non-Experience Rated Record
060-I	A	Y	mic	Contributions > 0 for Non-Experience Rated Record
062-I	A	Y	mic	Taxable Wages > Total Wages
063-I	A	Y	mic	Contributions > Taxable Wages
064-I	A		mic	MEEI/Reporting Unit Number (RUN) Inconsistent
065-I	A		mic	Inconsistent County/Township Combination
066-I	B		mic	Invalid Format in Predecessor Account
067-I	B		mic	Invalid Format in Successor Account
070-I	A		mic	No Usable Address
072-I	A		mic	Both Trade Name and Legal Name are Blank
074-I	B		mic	Invalid Old Ownership
075-I	B		mic	Invalid Old County

Edit Code	ABC	Pub Ex	Mic, Mac or Both	Edit Message
076-I	B		mic	Invalid Old County/Old Township Combination
078-I	B		mic	Invalid Old NAICS Code
080-I	A		mic	Indian Tribal Indicator Inconsistent with NAICS or OWN
<i>Level 6 – Warning Edits</i>				
085-W	A		mic	Potential Predecessor (UI #) found based on Wage Records
086-W	A		mic	Potential Successor (UI #) found based on Wage Records
088-W	B		mic	Large Record without Usable Physical Location Address (PLA)
<i>Level 5 – Significant Employment and Wage Edits</i>				
089-W	A		WIN mic/mac	WIN-202 Only: Month 1 Employment Change Greatly Exceeds Test Parameters
090-W	A		WIN mic/mac	WIN-202 Only: Month 2 Employment Change Greatly Exceeds Test Parameters
091-W	A		mic/mac	EXPO and BLS: Employment Change Greatly Exceeds Test Parameters WIN-202: Month 3 Employment Change Greatly Exceeds Test Parameters
092-W	A		mic/mac	AQW Change is Significantly > <i>PARM</i> And Exceeds Twice the Quartile AQW Range
093-W	A		mic/mac	Average Employment is Significantly > <i>PARM</i> , but Total Wages = 0
094-W	A		mic/mac	Average Employment = 0, but Total Wages is Significantly > <i>PARM</i>
095-W	A		mic	Total Wages = Sum of Empl +/- <i>PARM</i> if AME is Large
096-W	A		mic	Unusually Large New Record on File
097-W	A		mic	Unusually Large Discontinued Record Inactivated
099-W	A		mic	Questionable Large Imputation
<i>Level 6 – Warning Edits</i>				
101-W	C		mic	Unusable Address Type Code
102-W	C		mic	Blank Physical Location City; Other PLA Fields Present
103-W	C		mic	Unusable Physical Location State Abbreviation
104-W	C		mic	Unusable Physical Location Zip Code Format
105-W	C		mic	Unusable Telephone Format
106-W	C		mic	Blank UI City; Other UI Address Fields Present
107-W	C		mic	Unusable UI State Abbreviation
108-W	C		mic	Unusable UI Zip Code Format

Edit Code	ABC	Pub Ex	Mic, Mac or Both	Edit Message
109-W	C		mic	Blank Mailing/Other (M/O) City, Other M/O Address Fields Present
110-W	C		mic	Unusable Mailing/Other State Abbreviation
111-W	C		mic	Unusable Mailing/Other Zip Code Format
112-W	C		mic	Questionable Fax Number Format
114-W	C		mic	P.O. Box, Blank Street, or Out-of-State in PLA Block
116-W	A		mic	EIN missing for More Than <i>PARM</i> Months
118-W	C		mic	State Only: Computed Tax Rate > TOL % from Reported, and Computed Tax TOL from Reported
119-W	C		mic	First QTR Taxable Wages Missing for Experience-Rated Account
120-W	B		mic	Possible Non-Economic Code Change
121-W	B		mic	Code Change Back to a Recent Code
123-W	B		mic	Expected Code Change Not Made
124-W	C		mic	Inactive Record with Reported Employment/Wage Data
125-W	C		mic	Data Reported Prior to Liability Date
126-W	A		EXPO & BLS mic/mac	EXPO and BLS Only: Employment Change Exceeds Test Parameters (edits 136, 137, and 138 in WIN-202)
127-W	A		mic/mac	AQW Change > Parm and Exceeds Twice the Quartile AQW Range
128-W	C		mic	Identical Monthly Employment > <i>PARM</i>
129-W	C		mic	Taxable/Total Wage Ratio > Prior Year Ratio by <i>PARM</i> %
130-W	A		mic/mac	Average Employment > <i>PARM</i> , but Total Wages = 0
131-W	A		mic/mac	Average Employment = 0, but Total Wages > <i>PARM</i>
132-W	A		mic	Total Wages = Sum of Empl +/- <i>PARM</i>
133-W	A		mic	Unclassified Industry Empl > <i>PARM</i>
134-W	A		mac	Number of Establishments out of Range
135-W	A		mac	New or Discontinued Macro Record
136-W	A		WIN mic/mac	WIN-202 Only: Month 1 Employment Change Exceeds Test Parameters (edit 126 in EXPO and BLS)
137-W	A		WIN mic/mac	WIN-202 Only: Month 2 Employment Change Exceeds Test Parameters (edit 126 in EXPO and BLS)
138-W	A		WIN mic/mac	WIN-202 Only: Month 3 Employment Change Exceeds Test Parameters (edit 126 in EXPO and BLS)
139-W	A		mic	New Record?
140-W	A		mic	Discontinued Record?

Edit Code	ABC	Pub Ex	Mic, Mac or Both	Edit Message
146-W	B		mic	Old Codes Are Inconsistent with 4 th Quarter Codes
<i>Level 7 – Predecessor/Successor Edits</i>				
156-W	B		mic	Predecessor/Successor County Code Change Conflict
157-W	B		mic	Predecessor/Successor Ownership Change Conflict
159-W	B		mic	Predecessor/Successor Township Code Change Conflict
160-W	A		mic	Both Predecessor and Successor Reported
161-W	A		mic	Neither Predecessor nor Successor Reported
164-W	B		mic	Predecessor/Successor NAICS Code Change Conflict
<i>Level 8 – Multi-establishment Edits</i>				
171-W	A		mic	First Month Empl Not in Balance
172-W	A		mic	Second Month Empl Not in Balance
173-W	A		mic	Third Month Empl Not in Balance
174-W	A		mic	Total Wages Not in Balance
175-W	A		mic	State Only: Taxable Wages Not in Balance
176-W	A		mic	State Only: Contributions Not in Balance
178-I	A		mic	Master Without Multiple Worksites
179-I	A		mic	Worksite Missing Master
180-I	A		mic	Single Account/Active Worksites
181-I	A		mic	Worksite Ownership Code Differs from Master
182-I	A		mic	Worksite Employer Identification Number (EIN) Differs from Master
185-I	A		mic	Inconsistent Indian Tribal Codes within the Multi Account
<i>Level 9 – Wage Record Edits</i>				
193-W	C		mic	First Month Empl > Wage Record Count
194-W	C		mic	Second Month Empl > Wage Record Count
195-W	C		mic	Third Month Empl > Wage Record Count
196-W	C		mic	All Months Empl = Wage Record Count
197-W	C		mic	Total Wages Vary from Wage Records
198-W	C		mic	Divergent Employment Trends

Appendix H – Edit Parameters

Parameters and tolerances are used to control the edit workload and focus edit exceptions to records that have a greater impact on the data. The following table provides a summary of states and BLS edit parameters and tolerances, in edit code order. Parameters that are used in more than one edit are listed with the lowest applicable edit code. The parameters are used in micro level editing, except where shown otherwise.

Most of these parameters are used in both the standard state QCEW systems and the national office. The table below includes the Program Constant (PK) numbers assigned to the parameters in the standard state systems, EXPO and WIN. The edits are described in detail in Appendix F.

Edit Code	Edit Name	Also Used in Edits	Parameter Name	Length	EXPO PK #	WIN PK #	State Default Value	BLS Default Value
045	Federal Employer Identification Number		AME for EIN Edit	6	066	070	5	5
046	ARS Response Code Year	074-076, 078, 146	Fiscal Year	4	-	-	Processing or fiscal year for current refiling	Current processing year, or fiscal year for the refiling just completed
047	Tax Rate Range		Maximum Tax Rate	6	001	001	15% (expressed as 015000 in EXPO; 15.00 in WIN)	15% (expressed as 015000)
047	Tax Rate Range		Minimum Tax Rate	6	002	002	0	0
063	Contributions > Taxable Wages	118	Employee Tax Rate	6	051	003	3% (expressed as 3000 in EXPO and 3.00 in WIN)	3% (expressed as 030000)
066	Predecessor Account Format		Predecessor and Successor AME Cutoff	6	006	004	0	0
067	Successor Account Format		Predecessor and Successor AME Cutoff	6	006	004	0	0
070	Address Edit		Address Edit Cutoff	6	069	095	5	5
072	Trade and Legal Name Edit		Cutoff Parm for Trade/Legal Name	6	070	096	3	3

Edit Code	Edit Name	Also Used in Edits	Parameter Name	Length	EXPO PK #	WIN PK #	State Default Value	BLS Default Value
074-076 078	Old Code Checks	046, 146	Fiscal Year	4			Processing or fiscal year for current refiling	Current processing year, or fiscal year for the refiling just completed
085	Potential Predecessor Check		Potential Predecessor/ Successor Employment	6	086	N/A	100	100
085	Potential Predecessor Check	198	Potential Predecessor/ Successor Employment %	6	087	N/A	75	75
086	Potential Successor Check		Potential Predecessor/ Successor Employment	6	086	N/A	100	100
086	Potential Successor Check	198	Potential Predecessor/ Successor Employment %	6	087	N/A	75	75
088	PLA Address Edit		PLA Address Parm	6	080	099	100	100
089/136	<i>WIN-202 only - See 091/126</i>							
090/137	<i>WIN-202 only - See 091/126</i>							
091/126	Monthly Employment Change (micro)	089/136, 090/137, 138 (WIN- 202)	Between Quarters Absolute Difference	2 (6 at BLS)	081	100	500	500
091/126	Monthly Employment Change (micro and macro)	089/136, 090/137, 138 (WIN- 202), 92/127	Between Quarters Percent Difference	2	082	101	.10	.10

Edit Code	Edit Name	Also Used in Edits	Parameter Name	Length	EXPO PK #	WIN PK #	State Default Value	BLS Default Value
091/126	Non Zero Employment Cutoff		Non Zero Employment Cutoff	6	075	088	50	50
091/126	Monthly Employment Change (micro and macro)	089/136, 090/137, 138 (WIN-202)	Split Level For Employment Difference	2	010	005	20	20
091/126	Monthly Employment Change (micro and macro)	089/136, 090/137, 138 (WIN-202)	Low Employment Maximum Employment Difference	2	011	006	15	15
091/126	Monthly Employment Change (micro and macro)	089/136, 090/137, 138 (WIN-202)	High Employment Maximum Employment Difference	2	012	007	40	40
091/126	Monthly Employment Change (micro and macro)	089/136, 090/137, 138 (WIN-202)	High Reporting Percent Change	2	013	008	10	10
091/126	Monthly Employment Change (micro and macro)	089/136, 090/137, 138 (WIN-202)	Reporting Percent Change	2	014	009	30	30
091/126	Monthly Employment Change (micro and macro)	089/136, 090/137, 138 (WIN-202)	Employment Check Multiplier	6	053	010	10	10
091/126	Small Record Bypass	089/136, 090/137, 138 (WIN-202)	Small Record Bypass	2	071	085	25	25

Edit Code	Edit Name	Also Used in Edits	Parameter Name	Length	EXPO PK #	WIN PK #	State Default Value	BLS Default Value
091/126	Small Macro Record Bypass	089/136, 090/137, 138 (WIN-202)	Small Macro Record Bypass	2 (3 at BLS)	073	086	100	100
091/126	Establishment Limit	089/136, 090/137, 138 (WIN-202)	Macro Number of Establishments Limit	6	076	087	100	100
092/127	Wage Change (macro)		Non Zero Wage Cutoff	6	N/A	090	2,000,000	2,000,000
092/127	Wage Change (micro and macro)	094/131	No Employment with TW Cutoff	6	007	015	100,000	100,000
092/127	Wage Change (micro and macro)	093/130	No Total Wages with AME Cutoff	2	008	011	15	15
092/127	Wage Change (micro and macro)		Total Wage Change Parm	6	019	012	15,000	15,000
092/127	Wage Change (micro and macro)	091/126, 089/136, 090/137, 138 (WIN-202)	Employment Check Multiplier	2	053	010	10	10
092/127	Wage Change (micro and macro)		Supplemental AME	6	057	071	75	75
092/127	Wage Change (micro and macro)		Supplemental Wage Difference	6	058	072	10,000	10,000
092/127	Wage Change	094/131	Total Wage Check Multiplier	2	059	013	10	10
092/127	Micro AME Wage Cutoff		AME Wage Cutoff (micro)	6	071	091	25	25
092/127	Micro Total Wage Cutoff		Total Wage Cutoff (micro)	6	072	092	100,000	100,000
092/127	Macro AME Wage Cutoff		AME Wage Cutoff (macro)	6	073	093	100	100

Edit Code	Edit Name	Also Used in Edits	Parameter Name	Length	EXPO PK #	WIN PK #	State Default Value	BLS Default Value
092/127	Macro Total Wage Cutoff		Total Wage Cutoff (macro)	6	074	089	500,000	500,000
092/127	TW Change Small Rec Bypass		TW Change Small Record Bypass	6	077	N/A	50,000	50,000
093/130	Employment Without Wages (micro and macro)		No Total Wages with AME Cutoff	2	008	011	15	15
093/130	Employment without Wages		No Wages but AME Multiplier	2	053	014	10	10
094/131	Wages Without Employment (micro and macro)		No Employment with TW Cutoff	6	007	015	100,000	100,000
094/131	Wages Without Employment		No Employment TW Cutoff Multiplier	6	059	016	10	10
095/132	Wages/ Employment Sum (micro and macro)		Employment Equals Total Wages Tolerance	2	041	017	5	5
095/132	Wages/ Employment Sum (micro and macro)		Employment Equals Total Wages AME Cutoff	6	042	018	100	100
095/132	Wages/ Employment Sum		Employment Equals Total Wages Multiplier	2	053	019	10	10
096/139	Large New Record		Large New Employer	6	060	073	250	250
097/140	Large Discontinued Record Check		Large Discontinued Record Check	6	060	074	250	250
099	Questionable Large Imputation Check		Large Imputation Employment	6	084	102	100	100
099	Questionable Large Imputation Check		Large Imputation Wages	6	085	103	10,000	10,000
104	Physical Location (P/L) Zip Code Format	108, 111	Zip Code AME Cutoff	6	005	020	250	250

Edit Code	Edit Name	Also Used in Edits	Parameter Name	Length	EXPO PK #	WIN PK #	State Default Value	BLS Default Value
104	Physical Location Zip Code Expansion Format	108, 111	Zip Code AME Cutoff	6	005	020	250	250
105	Telephone Number		Telephone AME Cutoff	6	005	021	999,999	999,999
108	UI Address Zip Code	104	Zip Code AME Cutoff	6	005	020	250	250
108	UI Address Zip Code Expansion Format		Zip Code AME Cutoff	6	005	020	250	250
111	Mailing/Other Zip Code Format		Zip Code AME Cutoff	6	005	020	250	250
111	Mailing/Other Zip Code		Zip Code AME Cutoff	6	005	020	250	250
112	Fax Edit		FAX AME Parm	6	005	021	99	99
114	Physical Address Format		Physical Location Address AME	6	006	022	5	5
116	Missing Federal Employer Identification Number		EIN Months Missing	2	052	024	6	6
116	Missing Federal Employer Identification Number		EIN AME Parm	6	062	023	50	50
118	Tax Rate Consistency		Maximum Tax Rate Deviation	6	027	025	0.33% (expressed as 330 in EXPO and 0.33 in WIN)	N/A
118	Tax Rate Consistency		Maximum Contributions Due Deviation	6	028	026	2.50 (expressed as 000250 in EXPO and 2.5 in WIN)	N/A

Edit Code	Edit Name	Also Used in Edits	Parameter Name	Length	EXPO PK #	WIN PK #	State Default Value	BLS Default Value
118	Tax Rate Consistency		Bypass Switch For California Rate	1	N/A	027	0	N/A
118	Tax Rate Consistency	063	Employee Tax Rate	6	051	003	3%	N/A
119	Missing Taxable Wage		Bypass Switch for California Taxable Wages	1	N/A	029	0	0
119	Missing Taxable Wages		Maximum Total Wages with No Taxable Wages	6	020	028	999,999	999,999
120	Non-Economic Code Change		Noneconomic Code Change Monthly Employment Parm	2	009	030	25	25
120	Non-Economic Code Change		Noneconomic Code Change Large Employment Parm	6	N/A	098	50	100
121	Reversed Code Change		Rev CCS AME (Reverse Code Change Parm)	6	009	094	100	100
124	Active Account		Active Account AME	2	009	032	99	99
124	Active Account		Active Account Total Wages	6	019	033	500,000	500,000
125	Liability		Liability Check Employment	2	009	034	99	99
125	Liability		Liability Check Wages	6	055	035	500,000	500,000
126	<i>See 091/126</i>							
127	<i>See 092/127</i>							
128	Identical Monthly Employment		Maximum Identical Employment AME	6	021	036	1,000	1,000
129	Taxable/ Total Wage Change		Taxable Wages To Total Wages Percent Tolerance	2	043	037	99	99

Edit Code	Edit Name	Also Used in Edits	Parameter Name	Length	EXPO PK #	WIN PK #	State Default Value	BLS Default Value
129	Taxable/ Total Wage Change		Taxable Wages To Total Wages AME	6	044	038	500	500
130	<i>See 093/130</i>							
131	<i>See 094/131</i>							
132	<i>See 095/132</i>							
133	NAICS=999999		Unclassified NAICS AME	2	018	039	50	50
135	New and Discontinued Edit (macro)		Discontinued Record AME	6	054	040	100	100
135	New and Discontinued Edit (macro)		New Record AME	6	054	041	100	100
139/96	New Record Check		New Record Check	6	061	075	50	50
140/97	Discontinued Record Check		Discontinued Record Check	6	061	076	50	50
146	Inconsistent Old Code Check		Inconsistent Old Code Check	6	N/A	N/A	N/A	50
136	<i>See 091/126</i>							
137	<i>See 091/126</i>							
138	<i>See 091/126</i>							
139	<i>See 096/139</i>							
140	<i>See 097/140</i>							
146	Inconsistent Old Code	046, 074 – 076, 078	Fiscal Year	4	—	—	Processing or fiscal year for current refiling	Current processing year, or fiscal year for the refiling just completed
156-157 159-161 164	Predecessor/Successor Edits		Pred/Succ Upper Parm	6	016	042	250	250

Edit Code	Edit Name	Also Used in Edits	Parameter Name	Length	EXPO PK #	WIN PK #	State Default Value	BLS Default Value
160	Predecessor/Successor Edits		Pred/Succ Lower Parm	6	015	043	25	25
171-173	Additivity/Balance (Monthly Employment)		First Employment Balance Split Level	2	030	050	N/A	50
171-173	Additivity/ Balance (Monthly Employment)		Second Employment Balance Split Level	2	031	053	N/A	1,000
171-173	Additivity/ Balance (Monthly Employment)		Low Employment Balance Tolerance	2	032	051	5	10
171-173	Additivity/Balance (Monthly Employment)		Mid-Size Employment Balance Tolerance	2	033	052	10	50
171-173	Additivity/ Balance (Monthly Employment)		High Employment Balance Tolerance	6	034	054	100	100
174	Additivity/ Balance (Total Wages)		First Wage Balance Split Level	6	035	055	N/A	50,000
174	Additivity/ Balance (Total Wages)		Second Wage Balance Split Level	6	036	058	N/A	999,999
174	Additivity/ Balance (Total Wages)		Low Wage Balance Tolerance	6	037	056	500	5,000
174	Additivity/Balance (Total Wages)		Medium Wage Mill Balance Tolerance (1/10%)	2	038	057	1% (expressed as 10 in EXPO; 1 in WIN)	10% (expressed as 10)
174	Additivity/Balance (Total Wages)		High Wage Balance Tolerance	6	039	059	10,000	100,000
176	Contributions Additivity/Balance		Contributions Percentage Applied To Balance	2	040	067	10	N/A
193	1 st Month Employment/ Wage Record Comp	196, 198	Maximum AME For Wage Record Edits Bypass	6	046	062	50	50

Edit Code	Edit Name	Also Used in Edits	Parameter Name	Length	EXPO PK #	WIN PK #	State Default Value	BLS Default Value
193	1 st Month Employment/ Wage Record Comp		Limit for Employment > Wage Record Count %	2	047	063	10	10
194	2 nd Month Employment/ Wage Record Comp		Maximum AME for Wage Record Edits Bypass	6	046	062	50	50
194	2 nd Month Employment/ Wage Record Comp		Limit for Employment > Wage Record Count %	2	047	063	10	10
195	3 rd Month Employment/ Wage Record Comp		Maximum AME for Wage Record Edits Bypass	6	046	062	50	50
195	3 rd Month Employment/ Wage Record Comp		Limit for Employment > Wage Record Count %	2	047	063	10	10
196	Wage Record Check	193-195, 198	Maximum AME For Wage Record Edits Bypass	6	046	062	50	50
197	TTL Wages/ Wage Record Wage Comp		Maximum AME For Wage Record Wage Edits Bypass	6	049	065	100	100
197	TTL Wages/ Wage Record Wage Comp		Limit For Total Wages > Wage Record Wages %	2	050	066	20	20
198	Divergent Employment Trends	193-195, 196	Maximum AME For Wage Record Edits Bypass	6	046	062	50	50

Edit Code	Edit Name	Also Used in Edits	Parameter Name	Length	EXPO PK #	WIN PK #	State Default Value	BLS Default Value
198	Divergent Employment Trends	085, 086	Potential Predecessor/ Successor Employment %	6	087	N/A	75	75
			BLS Table 9B Print Cutoff – Edit Level Two					300
			BLS Table 9B Print Cutoff – Edit Level Three					300
			BLS Table 9B Print Cutoff – Edit Level Four					300
			BLS Table 9B Print Cutoff – Edit Level Five					300
			BLS Table 9B Print Cutoff – Edit Level Six					300
			BLS Table 10 Print Cutoff – Edit Level Eight					600
			BLS Table 9B Print Cutoff – Edit Level Nine					300

Appendix I – Comment Codes

Valid QCEW comment codes are listed below. Section I.1 gives an abridged version with associated short titles, and Section I.2 gives the full version. Traditionally, comment codes are assigned by state staff to explain economic data fluctuations or other unusual circumstances. In recent years, more and more comment codes are being assigned directly by the respondent, on collection web sites, or through automated touchtone response systems. In addition, many reports are collected via EDI centers. These centers use standard edit/screening systems to flag unusual data movements and re-contact employers when necessary for clarification. This often results in entry of a comment code. However, **comment codes should not be used as validation of incorrectly reported data**. Consider the collection source when reviewing data and the reliability of the associated comment code.

On the abridged list, the codes are given in numerical order. On the full list, codes are typically grouped together based on the associated data elements. (Some codes may not follow this grouping since they are also being used to address new economic or reporting issues.) Use the comment code that best explains the data fluctuation, regardless of its grouping. On the full list, the "Direction" column shows whether employment or wages would typically increase (+), decrease (-), not move in a consistent direction (+/-), or not be affected (N/A). The "E/N" column indicates whether the data fluctuation or change is economic (E) or noneconomic (N).

Three comment code fields, as well as a 57-position Narrative Comment field, are available on state and BLS QCEW systems. The standard state systems include these fields on the Enhanced Quarterly Unemployment Insurance (EQUI) file. State staff should use the first comment code field to report the most relevant code, but may use one or two additional codes or the Narrative Comment field to explain the data further. Section 9.6 describes the use of comment codes in some detail.

I.1 – Comment Codes Short Titles

Code	Short Title
00	Multi worksite to single. Remaining worksite converted to single.
01	Seasonal increase
02	Seasonal decrease
03	More business (expansion)
04	Less business (contraction)
05	Short-term/specific business project starting or continuing
06	Short-term/specific business project completed or approaching completion
07	Layoff, not elsewhere classified
08	Strike, lockout, or other labor dispute
09	Temporary shutdown
10	Conversion or remodeling of facilities, retooling, or repair and maintenance of equipment resulting in employment decrease
11	Conversion or remodeling of facilities, retooling, or repair and maintenance of equipment resulting in employment increase
12	Internal reorganization, downsizing or bankruptcy resulting in an employment decrease
13	Internal reorganization resulting in an employment increase
14	Nonstandard work schedule
15	Intra-account (firm) transfers
16	Establishment moved out of state
17	Establishment moved into state
18	Active employer reporting zero employment and wages
19	Employment returns or returning to normal or a new normal after coded 07-18
20	Wage rate decrease
21	Wage rate increase (including COLAs)
22	Increase in percentage of lower-paid employees
23	Increase in percentage of higher-paid employees
24	Lower hourly earnings or wages because of piecework or lower incentive pay
25	Higher hourly earnings or wages because of piecework or higher incentive pay
26	Less overtime worked at premium pay or less overtime worked
27	Overtime worked at premium pay or more overtime pay
28	Stock options exercised and distributed
29	Severance pay distributed
30	Wages paid to employees working in pay periods not including the 12 th of the month and not shown in employment
31	Bonuses, executive pay, profits distributed, or unidentified lump-sum payments
32	Change in commissions
33	Faculty paid over a 9-month period. Lump-sum payments made at end of school term
34	Change in hourly earnings or pay due to change in amount of shift work with pay differential

Code	Short Title
35	Changes in hours, earnings, or wages due to legislation/administrative regulations
36	Pay returns or returning to normal or a new normal after coded 29-35
37	Not used by QCEW
38	Not used by QCEW
39	Decrease in employment resulting from a labor shortage
40	Shorter scheduled workweek; fewer hours worked; number of pay periods less than usual
41	Longer scheduled workweek; more hours worked; number of pay periods greater than usual
42	Decrease in part-time workers
43	Increase in part-time workers
44	Return to normal after end of paid vacation or receiving vacation pay or other paid leave
45	Paid vacation or receiving vacation pay or other paid leave
46	Unpaid vacation or unpaid leave
47	Return to normal after end of unpaid vacation or unpaid leave
48	Improved reporting
49	Working and receiving vacation pay
50	Adverse weather conditions
51	Fire disruption
52	Natural disaster disruption
53	Non-natural disaster disruption
54	Energy shortage
55	Data returns or returning to normal or new normal after coded 50-54, 56 or 57
56	Secondary-effects decrease
57	Secondary-effects increase
58	Environmental legislation
59	Defense-related buildups
60	Defense-related cutbacks
61	NAICS 2017 direct, consolidation, or split
62	Temporary use code
63	Temporary use code
64	Temporary use code
65	Temporary use code
66-74	Not used by QCEW
75	Change in tax rate
76	Change in reimbursing/non-reimbursing status
77	Change in UI coverage
78	Change in taxable wage base
79	Change in taxable wages and/or contributions
80	Change in unclassified to classified
81	Noneconomic code change
82	Economic code change

Code	Short Title
83	Employee leasing reporting change to or from a PEO
84	Not used by QCEW
85	New establishment or worksite
86	Establishment permanently out of business
87	Reactivated UI account or worksite
88	Establishment dissolution
89	Establishment merger or acquisition
90	Changed basis of reporting with more detail
91	Changed basis of reporting with less detail
92	Partial Predecessor/Successor transaction
93	Full Predecessor/Successor transfer
94	Not used by QCEW
95	Data verified using CES
96	Data used pending verification
97	Data verified using wage records
98	Data verified by EDIC
99	Data verified--see narrative

I.2 – Comment Codes Full Detail

General Business Conditions (01-49)

Employment Shifts (00-19)

<u>Code</u>	<u>Title</u>	<u>Direction</u>	<u>E/N</u>	<u>QCEW Description</u>
00	Multi worksite to single. Remaining worksite converted to single.	—	E/N	All but one worksite of a multi-establishment account sold or closed, remaining single worksite becomes a single account. Show predecessor/successor link from inactivated worksite to account (RUN = 00000).
01	Seasonal increase	+	E	Seasonal increase; seasonal reopening; hiring of school personnel at the beginning of the school term.
02	Seasonal decrease	—	E	Seasonal decrease; seasonal closing; layoff of school personnel at the end of the school term.
03	More business (expansion)	+	E	More business (other than seasonal); new orders; new long-term contracts; expansion. <i>Example:</i> New department store increases employment during several reference periods.
04	Less business (contraction)	—	E	Less business (other than seasonal); long-term contracts completed, nearing completion, or canceled; lack of orders; contraction. These conditions may result in layoffs.
05	Short-term/ specific business project starting or continuing	+	E	Short-term business project began, in progress, or for full duration during the reference period or short-term specific job or occurrences. <i>Examples:</i> construction, mining, or drilling project; television or movie production.

<u>Code</u>	<u>Title</u>	<u>Direction</u>	<u>E/N</u>	<u>QCEW Description</u>
06	Short-term/ specific business project completed or approaching completion	—	E	Short-term business project or specific job or occurrence completed or approaching completion since the last reference period.
07	Layoff, not elsewhere classified	—	E	Layoff of some or all employees began, in progress, or for full duration; these layoffs could not be attributed to any other reason. Also includes furloughs. (Establishments permanently out of business are coded 86, not 07.)
08	Strike, lockout, or other labor dispute	—	E	Strike, lockout, or other labor dispute began, in progress, or for full duration.
09	Temporary shutdown	—	E	Temporary shutdowns that are not due to business conditions. <i>Examples:</i> inventory, plant cleaning, opening of hunting season, plant-wide vacations, failure of health or safety inspections. (Permanent shutdowns – plant closings – are coded 86. Unplanned shutdowns due to external factors such as fire, flood, etc., are coded 50-55. Temporary shutdowns directly caused by strikes or labor disputes are coded 08.)
10	Conversion or remodeling of facilities, retooling, or repair and maintenance of equipment resulting in an employment decrease	—	E	Conversion or remodeling of facilities, model changeover, retooling, automation, modernization, repair and/or maintenance of equipment resulting in a permanent or temporary employment decrease.

<u>Code</u>	<u>Title</u>	<u>Direction</u>	<u>E/N</u>	<u>QCEW Description</u>
11	Conversion or remodeling of facilities, retooling, or repair and maintenance of equipment resulting in an employment increase	+	E	Conversion or remodeling of facilities, model changeover, retooling, automation, modernization, repair and/or maintenance of equipment resulting in a permanent or temporary employment increase.
12	Internal reorganization, downsizing, or bankruptcy resulting in employment decrease	—	E	Internal reorganization, downsizing, elimination or phase out of department(s), or bankruptcy resulting in a permanent or temporary employment decrease within the same account/worksites. (Predecessor/Successor link does not exist.) <i>Example:</i> Restructuring of branches or divisions may eliminate mid-level management positions. Use code 86 if firm/location is out of business.
13	Internal reorganization resulting in employment increase	+	E	Internal reorganization resulting in a permanent or temporary employment increase within the same account/worksites. (Predecessor/Successor link does not exist.) <i>Example:</i> Restructuring junior or mid-level management may create new divisions or branches with additional workload.
14	Nonstandard work schedule	+/-	E	Nonstandard work patterns such as working alternating work weeks, or selected weeks in a quarter.
15	Intra-account (firm) transfers	+/-	E	Intra-account (firm) transfers result in changes or shifts in employment. Show predecessor/successor link(s).
16	Establishment moved out of state	—	E	Establishment ceased operations within the state and relocated to a different state.
17	Establishment moved into state	+	E	Establishment relocated from another state and began operations within the state.

<u>Code</u>	<u>Title</u>	<u>Direction</u>	<u>E/N</u>	<u>QCEW Description</u>
18	Active employer reporting zero employment and wages	+/-	E	Active employer submits report with zero employment and wages (e.g., on the QCR or MWR, through EDI or MWR Web, etc.).
19	Employment returns or returning to normal or a new normal	+/-	E	Employment returns or returning to normal or a new normal after events coded 07-18. (Do not use if formerly coded 00-06.)

Pay Shifts (20-39)

<u>Code</u>	<u>Title</u>	<u>Direction</u>	<u>E/N</u>	<u>QCEW Description</u>
20	Wage rate decrease	—	E	Wage rate (hourly earnings, weekly or monthly pay, or annual salary) decreases. <i>Example:</i> re-negotiation of union contract resulting in a wage rate decrease.
21	Wage rate increase (including cost-of-living adjustments)	+	E	Wage rate (hourly earnings, weekly or monthly pay, or annual salary) increases as a result of annual pay increases, cost-of-living adjustments, across the board pay increases, etc. (Use code 35 for an increase in the national minimum wage.)
22	Increase in percentage of lower-paid employees	—	E	Increase in the percentage of lower-paid employees or a decrease in the percentage of higher-paid employees will cause the average pay of the unit or industry to decrease. <i>Example:</i> Higher-paid employees on strike are replaced with new, lower-paid employees.
23	Increase in percentage of higher-paid employees	+	E	Increase in the percentage of higher-paid employees or a decrease in the percentage of lower-paid employees will cause the average pay of the unit or industry to increase. <i>Example:</i> company decreases the number of lower-paid laborers.

<u>Code</u>	<u>Title</u>	<u>Direction</u>	<u>E/N</u>	<u>QCEW Description</u>
24	Lower hourly earnings or wages because of piecework or lower incentive pay	—	E	Lower hourly earnings or wages caused by less piecework activity or due to end of work on rated job or a reduction in incentive pay.
25	Higher hourly earnings or wages because of piecework or higher incentive pay	+	E	Higher hourly earnings or wages caused by more piecework activity or due to work on rated job or an increase in incentive pay.
26	Less overtime worked at premium pay or less overtime worked	—	E	Less overtime worked at premium pay or less overtime worked.
27	Overtime worked at premium pay or more overtime pay	+	E	Overtime worked at premium pay including daily and weekend work or more overtime pay.
28	Stock options exercised and distributed	+	E	Stock options exercised and distributed.
29	Severance pay distributed	+	E	Employer distributes severance pay to laid-off employees.
30	Wages paid to employees working in pay periods not including the twelfth of the month and not shown in employment	—	N	Employer was in business during the reference period and paid wages in the quarter; however, most or all employees worked in pay periods other than the pay period including the twelfth of any month of the reference period.

<u>Code</u>	<u>Title</u>	<u>Direction</u>	<u>E/N</u>	<u>QCEW Description</u>
31	Bonuses, executive pay, profits distributed, or unidentified lump-sum payments	+	E	Bonuses, executive pay (an employer pays self), profit distribution, or lump-sum payments paid to employees other than faculty. (Use code 33 for lump-sum payments to faculty.)
32	Change in commissions	+/-	E	Increase/decrease in commissions paid.
33	Faculty paid over a nine-month period. Lump-sum payments made at end of school term	+	E/N	Faculty are typically paid over a nine-month period or during the school term. At the end of the school term, a lump-sum payment is made for the remainder of the year.
34	Change in hourly earnings or pay because of change in amount of shift work with pay differential	+/-	E	Change in wages because of a change in the amount of shift work with a pay differential.
35	Change in hours, earnings, or wages due to legislation or administrative regulations	+/-	E	Change in wages due to legislation or administrative regulations. <i>Example:</i> change in the minimum wage.
36	Pay returns or returning to normal or a new normal	+/-	E/N	Wages return or returning to normal or a new normal after events coded 29-35.
37				DO NOT USE. NOT A COMMENT CODE USED IN QCEW.
38				DO NOT USE. NOT A COMMENT CODE USED IN QCEW.

<u>Code</u>	<u>Title</u>	<u>Direction</u>	<u>E/N</u>	<u>QCEW Description</u>
39	Decrease in employment or a change in wages resulting from a labor shortage.	+/-	E	Employment decreases due to labor shortage (i.e., cannot find qualified workers to replace workers that have left). Change in wages because of a labor shortage.

Hours (Time & Vacation) (40-49)

<u>Code</u>	<u>Title</u>	<u>Direction</u>	<u>E/N</u>	<u>QCEW Description</u>
40	Shorter scheduled workweek or fewer hours worked. Number of pay periods less than usual.	—	E	Shorter scheduled workweek or fewer hours worked.
		—	N	Number of pay periods is less than usual or is lower when the number of pay periods fluctuates between six and seven pay periods in the quarter.
41	Longer scheduled workweek or more hours worked. Number of pay periods greater than usual.	+	E	Longer scheduled workweek or more hours worked.
		+	N	Number of pay periods is greater than usual or is higher when the number of pay periods fluctuates between six and seven pay periods in the quarter. <i>Example:</i> a quarter with seven pay periods for biweekly payroll establishments.
42	Decrease in part-time workers	+/-	E	Decrease in part-time workers, part-time workers become full-time or given increased hours, or a decrease in job-sharing resulting in a change in total or average wages.
43	Increase in part-time workers	+/-	E	Increase in part-time staff, working shorter workweeks or working for a short duration, or an increase in job-sharing resulting in a change in total or average wages.
44	Return to normal after end of paid vacation or receiving vacation pay or other paid leave	+/-	E	Return to normal after the end of PAID leave, vacation, or vacation pay.

<u>Code</u>	<u>Title</u>	<u>Direction</u>	<u>E/N</u>	<u>QCEW Description</u>
45	Employees on paid vacation or receiving vacation pay or other paid leave	+/-	E	Employees on PAID leave or vacation. (Use code 49 for employees who are both working and receiving vacation pay.)
46	Employees on unpaid vacation or unpaid leave	+/-	E	Employees on UNPAID leave or vacation.
47	Return to normal after end of unpaid vacation or unpaid leave	+/-	E	Return to normal after the end of UNPAID leave or vacation.
48	Improved reporting	+/-	N	Employer reports correctly after a period of prorated, imputed or inaccurate data. Data now unrelated to previous data.
49	Employees working and receiving vacation pay	+/-	E	Employees are working and receiving vacation pay.

Special Conditions (50-60)

External Factors (50-55)

Use these codes when the reason for a change is due to external factors.

<u>Code</u>	<u>Title</u>	<u>Direction</u>	<u>E/N</u>	<u>QCEW Description</u>
50	Adverse weather conditions	+/-	E	Data change because of adverse weather conditions. <i>Examples:</i> blizzards, hurricanes, and tornadoes.
51	Fire disruption	+/-	E	Data change because of a fire.
52	Natural disaster disruption	+/-	E	Data change because of natural disasters. <i>Examples:</i> earthquakes, floods, rock slides, insect infestations.

<u>Code</u>	<u>Title</u>	<u>Direction</u>	<u>E/N</u>	<u>QCEW Description</u>
53	Nonnatural disaster disruption	+/-	E	Data change because of nonnatural disasters. <i>Examples:</i> explosions, flooding caused by sprinkler systems.
54	Energy shortage	—	E	Activities curtailed or reduced because of shortage in the supply of natural gas, oil, coal, electricity, etc.
55	Data return or returning to normal or a new normal	+/-	E	Data return or returning to normal or a new normal after events coded 50-54, 56, or 57.

Secondary Effects (55-57)

Use these codes when the reason for a change in employment or other data is due to secondary effects from situations other than those due to defense-related changes.

<u>Code</u>	<u>Title</u>	<u>Direction</u>	<u>E/N</u>	<u>QCEW Description</u>
55	Data return or returning to normal or a new normal	+/-	E	Data return or returning to normal or stabilizing after events coded 50-54, 56, or 57.
56	Secondary-effects decrease	—	E	Data decrease or activities cease or decrease in non-defense-related industries because of the secondary effects of adverse weather conditions, fires, floods, natural disasters, nonnatural disasters, energy shortages, strikes, materials shortages, or service disruptions. <i>Example:</i> a manufacturer or supplier of auto parts lays off employees because the demand for the product has declined due to a strike in the auto industry. (Secondary effects of defense-related cutbacks are coded 60.)

<u>Code</u>	<u>Title</u>	<u>Direction</u>	<u>E/N</u>	<u>QCEW Description</u>
57	Secondary-effects increase	+	E	Data increase or activities resume or increase in non-defense-related industries because of the secondary effects of adverse weather conditions, fires, floods, natural disasters, nonnatural disasters, energy shortages, strikes, materials shortages, or service disruptions. <i>Example:</i> Construction activity increases due to rebuilding because of a fire or flood. (Secondary effects of defense-related buildups are coded 59.)

Environmental Legislation (58)

Use this code when the reason for a change is due to environmental issues.

<u>Code</u>	<u>Title</u>	<u>Direction</u>	<u>E/N</u>	<u>QCEW Description</u>
58	Environmental legislation	+/-	E	Data affected by environmental legislation.

Defense-Related (59-60)

Use these codes when the reason for a change is due to defense-related changes.

<u>Code</u>	<u>Title</u>	<u>Direction</u>	<u>E/N</u>	<u>QCEW Description</u>
59	Increase in employment due to defense-related buildups	+	E	Increased funding or activities result in higher employment in defense-related industries or businesses dependent on them. <i>Examples:</i> A firm receives a large defense contract or subcontract, or stores and restaurants near a defense supplier experience an increase in business. Note: Secondary effects (increases) specific to defense-related industries are coded 59, <u>not</u> 57.

<u>Code</u>	<u>Title</u>	<u>Direction</u>	<u>E/N</u>	<u>QCEW Description</u>
60	Decrease in employment due to defense-related cutbacks	—	E	Decreased funding or activities result in lower employment in defense-related industries or businesses dependent on them. <i>Example:</i> A firm completes a large defense contract or subcontract; restaurant near a military base loses employment due to a reduction in force at the base. Note: Secondary effects (decreases) specific to defense-related industries are coded 60, <u>not 56.</u>

Note: The NAICS codes of defense-focused establishments were reviewed to pinpoint those NAICS industries with the most defense related employment. The list below provides the NAICS industries that may be most directly affected by changes in government funding or activities.

NAICS	NAICS Title	Relevant Index Item
23, Construction		
236220	Commercial and Institutional Building Construction	Armory construction
237990	Other Heavy and Civil Engineering Construction	Missile facility construction
31-33, Manufacturing		
314999	All Other Miscellaneous Textile Product Mills	Military insignia textile mfg.
315210	Cut and Sew Apparel Contractors	Field jackets, military, cut and sew apparel contractors
315220	Men's and Boys' Cut and Sew Apparel Manufacturing	Field jackets, military, men's and boy's, cut and sewn from purchased fabric (except apparel contractors)
315240	Women's, Girls', and Infants' Cut and Sew Apparel Manufacturing	Military dress uniforms, tailored, women's and girls
325920	Explosives Manufacturing	Explosives manufacturing
331110	Iron and Steel Mills and Ferroalloy Manufacturing	Armor plate made in iron and steel mills
332322	Sheet Metal Work Manufacturing	Casings, sheet metal (except stampings), manufacturing
332912	Fluid Power Valve and Hose Fitting Manufacturing	Hydraulic aircraft subassemblies manufacturing
332992	Small Arms Ammunition Manufacturing	Small arms ammunition (i.e., 30 mm. or less, 1.18 inch or less) manufacturing

NAICS	NAICS Title	Relevant Index Item
332993	Ammunition (except Small Arms) Manufacturing	Grenades, hand or projectile, manufacturing
332994	Small Arms, Ordnance, and Ordnance Accessories Manufacturing	Aircraft artillery manufacturing
332999	All Other Miscellaneous Fabricated Metal Product Manufacturing	Military insignia metal mfg.
333314	Optical Instrument and Lens Manufacturing	Gun sights, optical, manufacturing
333318	Other Commercial and Service Industry Machinery Manufacturing	Flight simulation machinery manufacturing
333611	Turbine and Turbine Generator Set Units Manufacturing	Turbine generator set units manufacturing
333999	All Other Miscellaneous General Purpose Machinery Manufacturing	Aircraft carrier catapults manufacturing
334111	Electronic Computer Manufacturing	Computers manufacturing
334220	Radio and Television Broadcasting and Wireless Communications Equipment Manufacturing	Space satellites, communications, manufacturing
334412	Bare Printed Circuit Board Manufacturing	Circuit boards, printed, bare, manufacturing
334413	Semiconductor and Related Device Manufacturing	Infrared sensors, solid-state, manufacturing
334418	Printed Circuit Assembly (Electronic Assembly) Manufacturing	Loaded computer boards manufacturing
334419	Other Electronic Component Manufacturing	Cathode ray tubes (CRT) manufacturing
334511	Search, Detection, Navigation, Guidance, Aeronautical, and Nautical System and Instrument Manufacturing	Warfare countermeasures equipment manufacturing
334514	Totalizing Fluid Meter and Counting Device Manufacturing	Tank truck meters manufacturing
334515	Instrument Manufacturing for Measuring and Testing Electricity and Electrical Signals	Measuring equipment for electronic and electrical circuits and equipment manufacturing
334516	Analytical Laboratory Instrument Manufacturing	Atomic force microscopes manufacturing

NAICS	NAICS Title	Relevant Index Item
334519	Other Measuring and Controlling Device Manufacturing	Aircraft engine instruments manufacturing
336411	Aircraft Manufacturing	Aircraft manufacturing
336412	Aircraft Engine and Engine Parts Manufacturing	Engines and engine parts, aircraft manufacturing
336413	Other Aircraft Parts and Auxiliary Equipment Manufacturing	Aircraft assemblies, subassemblies, and parts (except engines) manufacturing
336414	Guided Missile and Space Vehicle Manufacturing	Rockets (guided missiles), space and military, complete, manufacturing
336415	Guided Missile and Space Vehicle Propulsion Unit and Propulsion Unit Parts Manufacturing	Developing and producing prototypes for guided missile and space vehicle engines
336419	Other Guided Missile and Space Vehicle Parts and Auxiliary Equipment Manufacturing	Guided missile and space vehicle parts (except engines) manufacturing
336611	Ship Building and Repairing	Ships (i.e., not suitable or intended for personal use) manufacturing
336992	Military Armored Vehicle, Tank, and Tank Component Manufacturing	Tanks, military (including factory rebuilding), manufacturing
336999	All Other Transportation Equipment Manufacturing	Off-highway tracked vehicles mfg.
42, Wholesale Trade		
423610	Electrical Apparatus and Equipment, Wiring Supplies, and Related Equipment Merchant Wholesalers	Industrial controls, electrical, merchant wholesalers
423690	Other Electronic Parts and Equipment Merchant Wholesalers	Communications equipment merchant wholesalers
423860	Transportation Equipment and Supplies (except Motor Vehicle) Merchant Wholesalers	Military vehicles (except trucks) merchant wholesalers
423990	Other Miscellaneous Durable Goods Merchant Wholesalers	Ammunition (except sporting) merchant wholesalers
48, Transportation and Warehousing		
488190	Other Support Activities for Air Transportation	Aircraft maintenance and repair services (except factory conversion, factory overhaul, factory rebuilding)
488390	Other Support Activities for Water Transportation	Ship dismantling at floating drydock
51, Information		
511210	Software Publishers	Software publishers

NAICS	NAICS Title	Relevant Index Item
517919	All Other Telecommunications	Satellite tracking stations
518210	Data Processing, Hosting, and Related Services	Computer data storage services
54, Professional and Technical Services		
541330	Engineering Services	Engineering services
541360	Geophysical Surveying and Mapping Services	Aerial geophysical surveying services
541511	Custom Computer Programming Services	Computer software programming services, custom
541512	Computer Systems Design Services	CAD (computer-aided design) systems integration design services
541513	Computer Facilities Management Services	Computer systems facilities (i.e., clients' facilities) management and operation services
541614	Process, Physical Distribution, and Logistics Consulting Services	Customs consulting services
541690	Other Scientific and Technical Consulting Services	Energy consulting services
541713	Research and Development in Nanotechnology	Nanobiotechnologies research and experimental development laboratories
541715	Research and Development in the Physical, Engineering, and Life Sciences (except Nanotechnology and Biotechnology)	Guided missile and space vehicle engine research and development
56, Administrative and Waste Services		
561210	Facilities Support Services	Military base support services
561612	Security Guards and Patrol Services	Patrol services, security
561613	Armored Car Services	Armored Car Services
61, Education Services		
611110	Elementary and Secondary Schools	Military academies, elementary or secondary
611310	Colleges, Universities, and Professional Schools	Academies, military service (college)
611512	Flight Training	Military flight instruction training
611519	Other Technical and Trade Schools	Specialized military training (except flight instruction, academies, and basic training)
71, Arts, Entertainment, and Recreation		
712110	Museums	Military museums
81, Other Services, Except Public Administration		
811212	Computer and Office Machine Repair and Maintenance	Computer equipment repair and maintenance services without retailing new computers
811213	Communication Equipment Repair and Maintenance	Communication equipment repair and maintenance services

NAICS	NAICS Title	Relevant Index Item
811219	Other Electronic and Precision Equipment Repair and Maintenance	Radar and sonar equipment repair and maintenance services
92, Public Administration		
928110	National Security	Armed forces

Temporary Codes (61-64)

States and/or regional offices may request the establishment of a temporary code. Temporary codes are set up and removed by the national office and new codes are made available to the states and regional offices.

Temporary codes are to be used when it has been determined that a situation...

- May not fit any of the existing comment codes,
- Applies to an entire area, region, or industry, and
- Typically will last for a short duration, but is not a permanent change.

Note: QCEW used code 61 to identify records that were impacted by the 2017 NAICS revision.

<u>Code</u>	<u>Title</u>	<u>Direction</u>	<u>E/N</u>	<u>QCEW Description</u>
61	NAICS 2017 Direct, Consolidation, or Split	+/-	N	Change in the record's NAICS code effective first quarter 2017 resulting from a direct one-to-one NAICS revision change, a consolidation of more than one NAICS code to one code, or the records coded in one code recoded into one of a limited set of codes split from the original code.

State-Specific Codes (65-74) (Currently not used by QCEW)

Ten codes previously reserved exclusively for state-specific CES use. These may be used in the future by QCEW.

Tax or Coverage Changes (75-79)

Information on tax rate changes, taxable wage base changes, coverage changes, etc., should be provided to the regional office in a timely manner as well as be included in the remarks section of the EQUI Transmittal Form.

<u>Code</u>	<u>Title</u>	<u>Direction</u>	<u>E/N</u>	<u>QCEW Description</u>
75	Change in tax rate	+/-	E	Change in the employer's tax rate or in the industry's overall tax rate causes a notable change in the contributions due or in the contributions-to-taxable-wages ratio.
76	Change in reimbursing/ nonreimbursing status	+/-	E	Change in the status from reimbursing to nonreimbursing status or from nonreimbursing to reimbursing status.
77	Change in UI coverage	+/-	E	Change from non-UI-covered status to UI-covered status or from UI-covered status to non-UI-covered status.
78	Change in taxable wage base	+/-	E	Change in the taxable wage base results in a change in taxable wages and contributions from expected levels.
79	Change in taxable wages and/or contributions	+/-	E	Change in taxable wages and/or contributions. <i>Examples:</i> an increase may result from hiring new employees after typical taxable wage obligations are met (excluding first quarter) causing an unusual increase in taxable wages and contributions. A decrease may result from an unusual layoff of employees causing an unexpected drop in taxable wages and contributions. Also included in this code would be cases where the taxable-wage-to-total-wage ratio is atypical. <i>Example:</i> a significant number of higher-paid employees would have total wages higher than the taxable wage base.

Coding and Classification Changes (80-82)

Coding and classification changes are divided into three types, defined in Section 2.3.1.

- Unclassified to classified
- Noneconomic changes
- Economic changes

Note: Comment codes are not required, but can be helpful, for noneconomic code changes with an appropriate ARS Response Code.

<u>Code</u>	<u>Title</u>	<u>Direction</u>	<u>E/N</u>	<u>QCEW Description</u>
80	Change in unclassified (NAICS 999999 or county 9xx) to classified NAICS or county	+/-	N	Unclassified or unknown NAICS or county code changed to a classified NAICS code (from NAICS 999999 to another NAICS) or to a classified county (from county 995-999 to a specific county code).
81	Noneconomic code change	+/-	N	Change in NAICS, county, township (New England and New Jersey), and/or ownership code as a result of a noneconomic code change.
82	Economic code change	+/-	E	Change in NAICS, county, township (New England and New Jersey), and/or ownership code as a result of an economic code change.

Reporting Issues (00, 83-93)

Use these codes when reporting practices change but the employer did not alter operations, or when the content or scope of the report changed.

83	Data previously reported by the firm are reported now by a Professional Employer Organization (PEO); data previously reported by a PEO are reported now by the firm	+/-	N	Data previously reported by the firm are reported now by a PEO/Leasing Firm or data previously reported by a PEO/Leasing Firm are now reported by the firm. Where possible, include predecessor/successor links.
84		+/-	N	DO NOT USE. NOT A COMMENT CODE USED IN QCEW.
85	New establishment or worksite	+	E	New establishment or worksite. If an employer had multiple worksites and started to report each separately (e.g., on the Multiple Worksite Report), those new breakouts would be coded 90. If the same employer opened a brand new worksite, that new unit would be coded 85.
86	Establishment permanently out of business	+/-	E	Establishment is permanently inactivated or out of business. (Use alternative codes, 02, 04, or 06-10, for temporary business disruptions.)
87	Reactivated UI account or worksite	+/-	E/N	Account or worksite report reactivated after being coded inactive or out-of-business.

88	Establishment dissolution	—	E/N	Some worksites or portions of the UI account are sold or reorganized into more than one new establishment with new UI account numbers. When this occurs, the worksite(s) or portions of the original UI account are in the process of closing. There is typically a continual decrease in employment. (Use comment code 86 when the UI account/worksite is inactive or finally has zero or near-zero employment and wages.) Do not use for new units or breakout of new QCEW worksites.
89	Establishment merger/acquisition	N/A	E/N	Existing establishment buys or acquires all or some worksites or portions of another UI account(s). Show a predecessor/successor link with comment code 92 or 93 to identify partial or full transaction.
90	Reporter changes basis of reporting — greater detail	N/A	N	UI account has made a change in its basis of reporting resulting in a report with more detail, providing new or improved multi-establishment breakout either by providing a new account breakout or breakout of an existing worksite for the first time. Show Predecessor/Successor links.
91	Reporter changes basis of reporting — less detail	N/A	N	UI account has made a change in its basis of reporting resulting in a report with less detail, either collapsing the entire account or some combination of worksites. Show Predecessor/Successor links.

92	Partial Predecessor/ Successor transactions	N/A	E/N	<p>New or existing UI account/worksite(s) that represents a partial predecessor/successor relationship. Such relationships occur when:</p> <ul style="list-style-type: none"> • A predecessor's employees and/or business are acquired by more than one UI account/worksite. The successors may or may not have previously existed. OR • The predecessor continues to exist, but some of the employees or portions of the business are acquired by one or more UI accounts/worksites. OR • A portion of the predecessor's employees are acquired by one or more UI accounts/ worksites, and the balance of employment can be explained by an economic event such as a layoff or closing. <p>Show Predecessor/Successor links.</p>
93	Full Predecessor/ Successor transfer	N/A	E/N	<p>New or existing UI account(s)/worksite(s) that represent a full successor relationship. The old UI account(s)/worksite(s) is/are either inactive or has zero employment.</p> <p>Show predecessor/successor link(s).</p>

Verification (94-99)

Use these codes when data are being verified or have been verified.

<u>Code</u>	<u>Title</u>	<u>Direction</u>	<u>E/N</u>	<u>QCEW Description</u>
94				DO NOT USE. NOT A COMMENT CODE USED IN QCEW.
95	Data verified using CES	+/-	N	Employment data verified by comparing Current Employment Statistics (CES) sample data with quarterly reports for the same reporting unit or UI account.
96	Data used pending verification	N/A	N	Data used as reported until an explanation and/or correction are received.
97	Data verified using Wage Records	+/-	N	QCEW data accepted by the state based on a comparison with data aggregated from wage records. Wage record employment totals cover the entire quarter and not each specific month. Therefore, wage record totals may be somewhat larger than QCEW employment, although total wages should be in close agreement. A review of individual wage records may also identify unusual wage payments or may explain significant changes in average wages.
98	Data verified/accepted by EDIC	+/-	N	The EDI Center (EDIC) will assign this code to worksite records they export to the states if they are satisfied that the data are accurate, and that none of the other codes is more appropriate. States should not assign or change this code, since it distinguishes EDIC-verified data from state-verified data.
99	Data verified, see narrative	N/A	E/N	Data verified, but cannot be explained by a standardized comment code. A Narrative Comment must be provided.

Appendix J – Imputation Formulas

The standard state systems, EXPO and WIN, include the capability to impute (estimate) economic data that the state has not received in time to complete quarterly processing. Imputation is discussed in general terms in Chapter 8 – Imputation of Missing and Delinquent Data. Chapter 8 focuses on state analysts' responsibilities for reviewing imputed data and related edit results, and for making changes where appropriate. This appendix provides detailed information about the imputation processing performed by the State systems.

Selection for Imputation

The standard state systems generate micro level imputations for the following situations:

- A delinquent account, where no employment or wage fields were reported, that last reported within a parameter-controlled number of quarters (typically no more than the last two) **or**
- A delinquent Multiple Worksite Report (MWR) and the account's master record was reported **or**
- A delinquent MWR and the account's master record was reported within the last two quarters **or**
- A delinquent master record if the current quarter MWR was reported **or**
- A current quarter missing at least one employment field data if the current quarter total wages were reported **or**
- Current quarter missing taxable wages or contributions if the current quarter total wages were reported **or**
- An MWR or master account Quarterly Contributions Report (QCR) is already imputed but new data were received which adjusts the missing data

The systems will not impute in the following cases:

- The account is inactive **or**
- The account did not report for a parameter-controlled number of quarters (typically the last two) **or**
- Imputations are not allowed by the program parameters **or**
- The account has been previously imputed or is fully reported **or**
- The worksite does not have a matching master record

For each record selected for imputation, the state system examines the initial liability and end of liability dates to determine if the record was only partially active during the quarter. If the end of liability date is within the processed quarter, the month and day are used to determine if the record was active for the entire quarter or only for one or two months. If the record was active for all three months an indicator is set to "3" but would be reduced by one for each month that the record was inactive based on the end of liability date. If the end of liability date is within the quarter, then the indicator would also be adjusted for the number of months in the quarter for which the account was not active.

If the indicator is less than three, a proration factor, *Prorate*, is computed as the fraction of the quarter for which the account is liable. The default for the *Prorate* is a factor of **1.0000000**. An account active for two months would be prorated by a factor of **0.6666667**; an account active for only one month would be prorated by a factor of **0.3333333**. Those with no full months of activity show a zero proration factor. This factor is used throughout the Total Wage and Employment imputation processes.

Nomenclature

In the pages that follow, several abbreviations and subscripts are used. Although these will generally be described with each specific method or formula, the list below provides a general reference. Key field names include:

Mon1	First month's employment
Mon2	Second month's employment
Mon3	Third month's employment
MonX	Any month's employment (indiscriminate)
TOTW	Total wages
TAXW	Taxable wages
CTRB	Contributions due

Subscripts are used for identifying quarters, as well as master, worksite, and macro record values. The subscript values include:

c	Current quarter data
cs	Current quarter summed worksite data, using only the units active in both current and prior quarter, less any worksites already used for current quarter prorations
p	Prior quarter data
ps	Prior quarter summed worksite data, using only the units active in both current and prior quarter, less any worksites already used for current quarter prorations
cy	Same quarter for prior year
py	Prior quarter for previous year
Mast	Master record value
Wkst	Worksite value
Mac	Macro record value
Inc _{Max}	Increase between quarters exceeds a parameter (e.g., 25% – state specific – applies only to non-seasonal accounts). $INC_{Max} = 1 + (\text{parm value}/100)$.
Dec _{Max}	Decrease between quarters exceeds a parameter (e.g., 20% – state specific – applies only to non-seasonal accounts). $DEC_{Max} = 1 - (\text{parm value}/100)$.

Indicator Flags and Code Settings

For each employment, total wage, taxable wage, and contributions due imputation, the state system assigns two codes. A 4-digit code explains if the imputation worked or failed and why it worked or failed. This code is not normally stored in the system but appears on output to help users review the results. The complete set of successful imputation codes and imputation failure codes are listed at the end of this appendix.

The second type of code is an indicator flag for each economic data field (monthly employment, total wages, taxable wages, and contributions). These indicator flags are stored on the state system and are submitted to national office on the EQUI file. Indicator flags are defined at the end of this appendix.

Before any economic data for the quarter are extracted, entered by state staff, or imputed, the state system contains zeros for the data field and "M" for the corresponding indicator. These are the initial values. If no reported data are extracted or entered, and if imputation fails, the initial values (zero data and indicator M) will be included on the EQUI file.

Imputation Methodology

The imputation information below is a compendium of formulae and features used in EXPO and/or WIN. Not all formulae and features are used by both systems. EXPO and WIN documentation should be used for more system specific details.

The imputation formulae are described by data element. state

Total Wage Imputation

Two situations determine if the Total Wages are missing. The first is simple: if the Total Wage Indicator flag is set to 'M', it is missing. The other condition is substantially more involved. If the Total Wages are imputed (with an 'E' indicator flag), and if it is a worksite (MEEI = 3 or 5) that is part of a multi whose Total Wages for all worksites are missing, and if the account's master record was modified, then Total Wages for the worksite are missing.

If Total Wages are not missing, an indicator of 'R' or blank is retained and the record is tested for Taxable Wages. An account that requires a Total Wage imputation is processed differently depending on its MEEI code. Master, single, and worksite records are each dealt with separately.

Master Account Total Wage Imputation (TOT1)

If some of the worksites of the UI account have reported Total Wages, the master record's Total Wages are imputed as the sum of the worksites' Total Wages. An 'S' Total Wage Indicator code and an imputation code **TOT1** are assigned, and the following formula is used.

$$TotW_c = \sum TotW_{wkst} \quad \text{Equation J-1}$$

Example:

Worksite	
<u>RUN</u>	<u>Total Wages</u>
00001	\$40,030
00002	20,045
00004	25,090
00005	32,115

$$TotW_c = \sum TotW_{wkst} = \$40,030 + \$20,045 + \$25,090 + \$32,115 = \$117,280$$

If the worksite Total Wages are not reported, this method is unusable. Since this is the only Total Wages imputation formula specifically for master records, masters not using this method will pass on to the single account imputation methods below.

Single Account Total Wage Imputation

If a single or master record (MEEI = 1, 2, 4, or 6) has any reported employment or wage data, the missing data fields are imputed regardless of how many quarters the data fields were already imputed. A parameter is used in each of the state systems to determine the number of quarters for which imputations can be continuously generated for a delinquent account.

If the delinquent account was already imputed for the number of consecutive quarters allowed (typically for two consecutive quarters), it would not be system-imputed again. An 'N' Total Wage Indicator and an Imputation Report Code of **TOTA** are assigned. The Total Wage data field will retain the zeroes it was originally assigned when the quarter was first initialized.

If an account has a seasonal code, the state systems will skip to the **Seasonal Account Total Wage Imputation** formula following the standard methodology. Seasonal codes are state record specific.

Total Wage Ratio Imputation (TOT2)

The prior-year same-quarter (e.g., 2020/4), and prior-year prior-quarter (e.g., 2020/3), Total Wages (i.e., four and five quarters before the processed quarter (e.g., 2021/4)) are checked for

non-zero values. If they are greater than zero, and the quarter immediately before the one processed (e.g., 2021/3) shows either reported or non-zero Total Wages, the **TOT2** edit is employed. A Total Wage Indicator code of 'E' is assigned to the record. This edit uses the following formula:

$$\text{Ratio} = \frac{\text{TotW}_{cy}}{\text{TotW}_{py}}$$

Equation J-2

If $\text{Ratio} > \text{Inc}_{\text{Max}}$ or $< \text{Dec}_{\text{Max}}$
Set Ratio to Limit

$$\text{TotW}_c = \text{Ratio} \times \text{TotW}_p \times \text{Prorate}$$

Where

$$\text{Inc}_{\text{Max}} = 1 + PK \frac{x}{100}$$

Equation J-3

$$\text{Dec}_{\text{Max}} = 1 - PK \frac{y}{100}$$

Example: Record was active throughout the entire quarter.

<u>Year/Q</u>	<u>Q</u>	<u>Total Wages</u>
2021/4	c	Missing TotW
2021/3	p	\$123,400
2021/2		127,900
2021/1		134,230
2020/4	cy	168,500
2020/3	py	125,120

$$\text{INC}_{\text{Max}} = 1 + (25/100) = 1.25$$

$$\text{DEC}_{\text{Max}} = 1 - (20/100) = .80$$

$$\text{Ratio} = \frac{\text{TotW}_{cy}}{\text{TotW}_{py}} = \frac{168,500}{125,120} = 1.3467$$

$$\text{Ratio} > \text{INC}_{\text{Max}}$$

$$\text{Ratio} = \text{Limit} = 1.25$$

$$\text{TotW} = \text{Ratio} \times \text{TotW}_p \times \text{Prorate (equal to 1 in this example)}$$

$$\text{TotW} = 1.25 \times 123,400 \times 1.0000000$$

$$\text{TotW} = 154,250$$

If this *TOT2* formula is used, processing continues on to the Taxable Wage Imputation. Otherwise, processing transfers to the **Other Total Wage Imputation for Singles** section, which follows the Seasonal Account Wage Imputation section below.

Seasonal Account Total Wage Imputation (*TOT3*)

This method no longer exists in EXPO but does in WIN. Seasonal accounts (i.e., those identified as seasonal for the particular state) are not subject to the maximum increase and maximum decrease restrictions used in the *TOT2* approach. Each state must identify those records that they choose to treat as seasonal accounts. If a record is treated as seasonal, ratio imputations (*TOT2*) are bypassed and the record is imputed using the method below.

Seasonal accounts require historical data from one year ago to make imputations for the processed quarter.

The seasonal account's Total Wage and First Month Employment Indicators from the year-ago quarter are checked for imputed or missing data. If either is reported, the *TOT3* imputation method is used:

$$TotW = TotW_{cy} \times Prorate \qquad \text{Equation J-4}$$

Example: Record was active throughout the entire quarter and is in a seasonal industry.

<u>Year/Q</u>	<u>Q</u>	<u>Total Wages</u>
2018/4	c	Missing TotW
2018/3	p	\$123,400
2018/2		127,900
2018/1		134,230
2017/4	cy	168,500
2017/3	py	125,120

$$TotW = TotW_{cy} \times Prorate$$

$$TotW = 168,500 \times 1.0000000 = 168,500.$$

If the *TOT3* formula is used, a Total Wage Indicator of 'E' is assigned, and processing then continues with the Taxable Wage Imputation section. Otherwise, continue to the other single unit Total Wage Imputation formulas.

Macro File Total Wages (TOT8)

This method no longer exists in EXPO but does in WIN. The remaining accounts will be processed using this Macro Total Wages imputation formula. Prior quarter and prior year's same quarter macro cell data are used.

The **TOT8** imputation method using the following formula:

$$TotW = \frac{TotW_p \times TotW_{Mac_{cy}}}{TotW_{Mac_p}} \times Prorate \quad \text{Equation J-5}$$

Here, the *Mac* subscripts indicate the Macro File data, *p* indicates prior quarter data, and *cy* indicates a prior-year, same-quarter value. The *Prorate* factor denotes the portion of the quarter during which the account is active. A Total Wage Indicator code of 'E' is assigned. Processing then continues with the Taxable Wage Imputation section.

Example:

The macro cell has prior quarter and prior year data. Record was active throughout the entire quarter and is in a seasonal industry.

<u>Year/Q</u>	<u>Total Wages</u>
TotW _c	Missing TotW
TotW _p	\$123,400
TotW _{Mac_{cy}}	927,900
TotW _{Mac_p}	934,230
Prorate	1.0000000

$$TotW = \frac{TotW_p \times TotW_{Mac_{cy}}}{TotW_{Mac_p}} \times Prorate$$

$$TotW = ((123,400 \times 927,900) / 934,230) \times 1.0000000 = 122,564.$$

If the Macro File records are not found, or if the prior quarter macro Total Wages are zero, or if the prior year's same quarter Total Wages is zero, the imputation fails and the imputation failure code of **TOTB** is assigned. Subsequent imputation attempts are bypassed unless the account's data are modified, clearing the edit flag. After the **TOTB** code is assigned, the state system will not impute Taxable Wages and Contributions but does attempt to impute employment.

Other Total Wage Imputation for Singles or Masters**Prior Quarter Total Wages (TOT4)**

This imputation method for non-seasonal single accounts uses the account's prior quarter total wages. If prior quarter Total Wages are zero, and they are either imputed or missing, then the state system will attempt to use current quarter employment to predict the current Total Wages.

If the employment is missing or imputed as well, a **TOTA** failure code (indicating that insufficient data exist to impute the Total Wages) is assigned. Taxable Wages and Contributions are also not imputable, and the programs will skip to the Employment Imputation section.

For an account with non-zero or reported data in the prior quarter Total Wages, the following **TOT4** imputation method is used:

$$TotW = TotW_p \times Prorate \quad \text{Equation J-6}$$

Note that the *p* subscript denotes prior quarter data and *Prorate* notes the proration factor, or the fraction of the quarter for which the account is active. A Total Wage Indicator code of 'E' is assigned if the Total Wages can be imputed using the **TOT4** method, and processing moves to the Taxable Wage Imputation section.

Example:

Record was active throughout the entire prior quarter and is in a seasonal industry.

<u>Year/Q</u>	<u>Total Wages</u>
TotW _c	Missing TotW
TotW _p	\$123,400
Prorate	1.0000000

$$TotW_c = TotW_p \times Prorate$$

$$TotW_c = 123,400 \times 1.0000000 = 123,400.$$

Total Wage Imputations Using Employment (TOT9)

These cases are very rare. Not only must both current and prior quarter total wages be missing but current quarter monthly employment as well as year ago macro employment must be reported. To attempt to make a Total Wage Imputation for this type of account, auxiliary macro information is needed.

If the Macro File record for the same industry, county, and ownership exists for the same quarter of the previous year and the employment and wage data are greater than zero, the **TOT9** formula is used. If one or both of these values is zero, the imputation fails with a failure code of **TOTE**.

When the macro data do exist and have both employment and wage data for the prior year’s same quarter, a total wage imputation can be generated, identified by the **TOT9** code (imputed from macro data). A Total Wage Indicator of ‘E’ is assigned. This is computed from the equation:

$$TotW = \frac{(Mon1 + Mon2 + Mon3) \times Prorate \times TotW_{Mac_{cy}}}{(Mon1_{Mac_{cy}} + Mon2_{Mac_{cy}} + Mon3_{Mac_{cy}})} \quad \text{Equation J-7}$$

in which *Mac* identifies macro data fields, *cy* represents the prior year’s same quarter data, and *Prorate* is the proration factor, denoting the fraction of the quarter during which the account is active. The program then moves to the Taxable Wage Imputation section.

Example: The macro cell has prior year data. The micro record was active throughout the entire quarter and has employment data.

<u>Year/Q</u>		<u>Micro Total</u> <u>Wages</u>	<u>Macro Total</u> <u>Wages</u>	<u>Mon1</u>	<u>Mon2</u>	<u>Mon3</u>
Current	TotW _c	Missing TotW				
Current, year ago	TotW _{cy}	\$123,400				
Micro Emp, current	Mon _{cy}			5	6	6
Macro Emp, year ago	Mon _{Macp}		1,567,000	50	55	55
	Prorate	1.0000000				

$$TotW_c = ((Mon1 + Mon2 + Mon3) \times Prorate \times TotW_{Mac_{cy}}) \div (Mon1_{Mac_{cy}} + Mon2_{Mac_{cy}} + Mon3_{Mac_{cy}})$$

$$TotW_c = ((17 \times 1.0000000 \times 1,567,000) \div (160)) = 26,639,000 \div 160 = 166,493.75 \cong 166,494$$

Worksite Total Wage Imputation (TOT5/TOT6)

Worksite Total Wage imputation uses the data from the master record and the other worksites to generate data for each worksite.

If some or all worksites are missing (for example, the MWR is not received), then the state system will attempt to impute the worksite data. If the current quarter’s master record could not be imputed, an imputation failure code of **TOTD** is assigned. If the prior quarter master record Total Wages are not available, then an imputation failure code of **TOTC** is assigned (indicating summed worksite and master Total Wages for the prior quarter do not exist).

If the master’s prior quarter Total Wages are zero, the worksite’s Total Wages are forced to zero, but no failure code results.

When this occurs, no imputation is made for Taxable Wages and Contributions for the missing worksites, and the program passes to the Employment Imputation section.

If none of the three previous conditions exist, the state system will impute the missing Total Wages for each worksite in the account with each receiving a successful imputation code of **TOT5**. The following formula is used:

$$\text{Ratio} = \frac{\text{Tot}W_{cs}}{\text{Tot}W_{ps}}$$

(Ratio = 0 if $\text{Tot}W_{ps} = 0$)

Equation J-8

$$\text{Tot}W = \text{Ratio} \times \text{Tot}W_{\text{Wkst}_p}$$

in which **cs** and **ps** represent specialized current quarter master and prior quarter worksite data, respectively, and **p** identifies the prior quarter value for the individual worksite. Initially the **cs** Total Wage value is just the master record's current quarter Total Wages. The **ps** wage value is initially the sum of worksite Total Wages from the prior quarter using only the units that remain active through both the prior and the current quarter.

After a worksite has been imputed in this manner the **cs** and **ps** wage values are adjusted by removing this worksite's current and prior quarter Total Wages, respectively. This is done using the following formulae

$$\text{Tot}W_{\text{csadjusted}} = \text{Tot}W_{cs} - \text{Tot}W$$

Equation J-9

$$\text{Tot}W_{\text{psadjusted}} = \text{Tot}W_{ps} - \text{Tot}W_{\text{Wkst}_p}$$

Equation J-10

in which the **TotW** value subtracted on the top line is the worksite's current quarter Total Wage value that was just imputed, and the value subtracted on the lower line is the same worksite's prior quarter Total Wages. This subtraction will produce a slightly different ratio for the next worksite in the multi, which will counterbalance any rounding errors that would normally occur by simply using a fixed ratio based upon the master account's current and prior quarter Total Wages. In addition, if some of the worksites had terminated at the end of the previous quarter, they will be excluded, eliminating an out-of-balance condition found when the inactive unit's wages are included in the master records data.

Once the worksite Total Wages are imputed for all active worksites, the program moves to the Taxable Wage Imputation section.

Example:

A multi-establishment account with ten reporting units had both the contribution report and the MWR reported in the previous quarter. The account's contribution report data were received and entered for the current quarter, but the current quarter MWR form was not received. The prior quarter total wages for the master were \$235,166, with \$247,804 reported for the current quarter. The ten worksites (reporting units numbered 00001 through 00010) total wages are listed below. Even though the account was out-of-balance by \$5 in the prior quarter, no adjustment was made to the reported data. The prorations of total wages for the current quarter are listed below.

<u>Worksite RUN</u>	<u>Previous Qtr Total Wages</u>	<u>TotW_{cs}</u>	<u>TotW_{ps}</u>	<u>Ratio</u>	<u>Current Qtr Total Wages</u>
00001	45,326	247,804	235,161	1.053763	47,763
00002	18,095	200,041	189,835	1.053762	19,068
00003	5,712	180,973	171,740	1.053762	6,019
00004	30,479	174,954	166,028	1.053762	32,118
00005	9,401	142,836	135,549	1.053759	9,906
00006	4,366	132,930	126,148	1.053762	4,601
00007	14,825	128,329	121,782	1.053760	15,622
00008	7,290	112,707	106,957	1.053760	7,682
00009	40,258	105,025	99,667	1.053759	42,422
00010	59,409	62,603	59,409	1.053763	62,603

For the table above,

- The first column is the reporting unit number (RUN),
- The second column shows the worksite's prior quarter Total Wages,
- The third column is the current quarter's master Total Wages less any current quarter worksite imputation already made,
- The fourth column denotes the prior quarter summed worksite Total Wages less any prior quarter Total Wages already accounted for in prior lines,
- The fifth column is the ratio of current to prior quarter Total Wages, and
- The sixth column is the worksite's estimated Total Wages for the new quarter.

Note: The worksite totals used in the prior quarter values (the *ps* subscript) will exclude any of the worksites that were active in the previous quarter but inactive in the imputed quarter. If this were not used, imputations would be short by the Total Wages represented in the inactivated worksites, which would cause an extensive amount of manual intervention to reconcile the out-of-balance condition.

The first worksite uses the full master account Total Wages divided by the prior quarter's summed worksite Total Wages to produce the first ratio. This ratio is multiplied by the prior quarter's worksite Total Wages to produce the imputed current quarter Total Wages for the worksite. Then the first reporting unit's prior quarter Total Wages are subtracted from the column 4 value to give the next line's revised prior quarter Total Wage sum. The imputed worksite's Total Wage value for the current quarter is subtracted from the column 3 value to produce the second line's current quarter Total Wages sum. The same process is repeated through the rest of the worksites. Rounding causes a particular unit's Total Wages to vary slightly from the original ratio, the adjusted current and prior quarter summed values produce a revised ratio to adjust for the discrepancy.

Using a constant ratio for worksite distribution produces an average variance from exact balancing that increases as the number of worksites increases. The imputed difference from an exact balance in either wages or employment is found from the equation:

$$Out - of - Balance_{Avg} = \frac{\sqrt{RUN Ct}}{2} \quad \text{Equation J-11}$$

where **RUN Ct** is a count of the number of RUNs for the account.

If the master record's Total Wages were reported (indicator "R"), then the worksite Total Wages that are generated are assigned a Total Wage Indicator code of 'P'. If, however, the master record was imputed, then the Total Wage Indicator code of 'E' would be assigned.

EXPO also allows the option of online seasonal proration of total wages. Total wages are prorated in the same manner as non-seasonal prorations except instead of using the prior quarter, year ago is used as the denominator of the ratio:

$$\begin{aligned} \text{Ratio}_{seas} &= \text{TotW}_{cs} \div \text{TotW}_{cys} \\ \text{TotW} &= \text{TotW}_{cy} \times \text{Ratio}_{seas} \end{aligned}$$

to project total wages forward.

Taxable Wage Imputation

Selection Criteria

Five fields (Status Code, Type of Coverage, Total Wages, Total Wage Indicator Code, and Taxable Wage Indicator Code) are used to determine if a Taxable Wage imputation should be made. The selection criteria for each field is:

- Status Code (impute unless inactive or impute if Status Code not equal to 2)
- Type of Coverage Code (must be experience-rated or Type of Coverage Code = 0 or 2)
- Taxable Wage Indicator Code (impute if M for missing as well as if E for imputed when the master record data were changed).
- Total Wages and the Total Wage Indicator (if Total Wages are zero or the Total Wages are missing (indicator M) and cannot be imputed, do not impute Taxable Wages)

Single and Master Taxable Wage Imputations (*TAXI*)

Total Wages greater than zero are required from the previous year’s same quarter to make a direct imputation for the Taxable Wages of an account. This method uses the following equation:

$$TaxW_c = \frac{TotW \times TaxW_{cy}}{TotW_{cy}} \qquad \text{Equation J-12}$$

where *cy* represents data from the previous year’s same quarter. Once the Taxable Wages are computed, an imputation is made for Contributions Due. (See the Contributions Due section after Worksite Taxable Wage Imputations.)

Example:

<u>Year/Q</u>	<u>Total Wage Formula</u>	<u>Total Wages</u>	<u>Taxable Wages Formula</u>	<u>Taxable Wages</u>
Current	TotW _c	765,000	TaxW	Missing
Current, year ago	TotW _{cy}	744,000	TaxW _{cy}	456,000

$$TaxW_c = (TotW_c \times TaxW_{cy}) \div TotW_{cy}$$

$$TaxW_c = (765,000 \times 456,000) \div 744,000 = (348,840,000,000 \div 744,000) \\ 468,870.97 \cong 468,871$$

If the record does not have Total Wages greater than zero, an imputation failure code of **TAXA** is assigned. This also means that the state system then passes on to the Employment Imputation Section since it is impossible to generate Contributions Due without Taxable Wages.

Worksite Taxable Wage Imputations (TAX3 and TAX4)

Worksite proration of Taxable Wages is made when the Taxable Wages and Total Wages were reported for the master record. In these cases, the Total Wages would have already been prorated from the master record's Total Wages. If the master record data were imputed, then the state system would attempt to impute the missing Taxable Wages based on the ratios of the imputed Total Wages.

If an imputation failure occurred for the master's Total Wages, the worksite's Taxable Wage imputation also fails and is coded **TAXC** (not imputed due to master imputation failure). If no Total Wage imputation failure occurred in the master account but the master record's Total Wages equal zero, the worksites are each assigned zero as their Taxable Wages and a successful imputation code of **TAX4** (zero Taxable Wages from master). In either case, it is impossible to impute Contributions Due. The process moves to the Employment Imputation section.

The remaining cases use the following formula to compute Taxable Wages for each worksite and are assigned the successful imputation code of **TAX3**. The formula is

$$TaxW_c = \frac{TotW_c \times TaxW_{Mast}}{TotW_{Mast}} \quad \text{Equation J-13}$$

in which *Mast* denotes the master account's data. This successful imputation moves the record to the Contribution Imputation section of the program, which is described below. As with Total Wages, however, rounding errors will be adjusted through the use of diminishing sums (taxable and total wages reduced by individual worksite values) as they are imputed.

Example:

A multi-establishment account has five reporting units for which the Taxable Wages need to be prorated. The QCR Total Wages are \$996,053 and its Taxable Wages are \$747,804. The five worksites (reporting units numbered 00001 through 00005) reported total wages on the MWR. The prorations of Taxable Wages for the current quarter are listed below.

<u>RUN</u>	<u>TotW_c</u>	<u>Adjusted TotW_{Mast}</u>	<u>Adjusted TaxW_{Mast}</u>	<u>TaxW_c</u>	<u>Ratio</u>
Master 00000	\$996,053	\$996,053	\$747,804	\$747,804	0.750767
00001	118,095	996,053	747,804	88,662	0.750767
00002	95,712	877,958	659,142	71,857	0.750767
00003	230,479	782,246	587,285	173,036	0.750768

<u>RUN</u>	<u>TotW_c</u>	Adjusted <u>TotW_{Mast}</u>	Adjusted <u>TaxW_{Mast}</u>	<u>TaxW_c</u>	<u>Ratio</u>
00004	129,401	551,767	414,249	97,150	0.750768
00005	422,366	422,366	317,099	317,099	0.750768

Contributions Due Imputation

It is impossible to have an imputation failure for Contributions. However, Taxable Wages must be greater than zero to produce an imputation for Contributions. Otherwise, Contributions Due is left as zero and the program passes to the Employment Imputation section.

Contributions Due is defined to be the Taxable Wage amount multiplied by the Tax Rate for the account. The Tax Rate of the master record is used to compute worksite Contribution prorations.

The successful imputation code is **CTBI**.

Single and Master Contributions

The formula for single and master imputations is:

$$Ctrb_c = \frac{(TxRt_{Int} \times TaxW_c)}{100,000} \quad \text{Equation J-14}$$

in which $TxRt_{Int}$ represents the tax rate (multiplied by 1000) of the account (or the master account if the imputation is performed on a worksite).

Example:

A single unit with \$87,549 in Taxable Wages and a Tax Rate of 2.17 has Contributions of:

$$\begin{aligned} Ctrb_c &= (TxRt_{Int} \times TaxW_c) \div 100,000 = ((2.17 \times 1000) \times 87,549) \div 100,000 \\ &= 189,981,330 \div 100,000 = 1,899.81 = 1,900 \end{aligned}$$

Worksite Contributions

The formula for worksite is:

$$Ctrb_c = \frac{(Ctrb_{cs} \times TaxW_c)}{TaxW_{cs}} \quad \text{Equation J-15}$$

This method uses the counterbalancing method for rounding errors. The *cs* subscript denotes the summed current quarter worksite expected values, which start out as the master account's Contribution and Taxable Wage values, but are decreased by each worksite's associated values.

The adjustments are

$$C_{trb}_{cs,Adjusted} = C_{trb}_{cs} - C_{trb} \qquad \text{Equation J-16}$$

$$T_{axW}_{cs,Adjusted} = T_{axW}_{cs} - T_{axW} \qquad \text{Equation J-17}$$

The Contributions-versus-Taxable-Wages ratio provides the worksite equivalent of Tax Rate for worksite Contribution imputation. As the values are reduced, however, the effective Tax Rate (summed Contributions divided by summed Taxable Wages) will vary slightly. This variation counteracts any potential cumulative effects of possible rounding errors so that the account remains in balance.

Example:

A multi-establishment account with five reporting units where the Taxable Wages have been prorated. The QCR Contributions Due need to be imputed.

<u>RUN</u>	<u>Adjusted</u> <u>C_{trb}_{Mast}</u>	<u>Adjusted</u> <u>T_{axW}_{Mast}</u>	<u>TaxW</u>	<u>C_{trb}</u>	<u>Ratio</u>
Master 00000	\$17,053	\$747,804	\$747,804	\$17,053	0.022804
00001	17,053	747,804	88,662	2,022	0.022804
00002	15,031	659,142	71,857	1,639	0.022804
00003	13,392	587,285	173,036	3,946	0.022803
00004	9,446	414,249	97,150	2,215	0.022803
00005	7,231	317,099	317,099	7,231	0.022804

The next step is the Employment Imputation procedure, described below.

Employment Imputation

Selection Criteria

If the employment indicator flags show ‘M’ for at least one month, then the state system will attempt to impute the missing employment. Worksites may also be re-imputed if the master record is received or is re-imputed. If the worksite has no historical quarter employment data upon which to base an imputation for the current quarter, the existing hand-generated imputation is left intact.

Once the system has determined whether any of the three months of employment require an imputation, the primary employment imputation process divides into two main processes, one for singles and master records, and one for worksites.

Single/Master Employment Imputations

Sum of Worksites (EMP2)

If the record is the master of a multi (MEEI code of 2), and if the worksite employment data are not fully delinquent (i.e., at least one of the worksites show reported data in the first month of employment), any missing employment months for the master account are imputed by summing the worksite data for the missing months using the **EMP2** imputation equations:

$$Mon1 = \sum Mon 1_{Wkst} \quad \text{Equation J-18}$$

$$Mon2 = \sum Mon 2_{Wkst} \quad \text{Equation J-19}$$

$$Mon3 = \sum Mon 3_{Wkst} \quad \text{Equation J-20}$$

in which *Wkst* denotes the worksite data.

Example:

An account’s MWR was received but the QCR is still missing. The master record is imputed using the sum of the worksite data.

<u>RUN</u>	<u>Mon1</u>	<u>Mon2</u>	<u>Mon2</u>
Master 00000	Missing	Missing	Missing
00001	53	47	48
00002	110	94	87

<u>RUN</u>	<u>Mon1</u>	<u>Mon2</u>	<u>Mon2</u>
00003	392	358	370
00004	94	89	97
00005	31	31	31

$$\text{Mon1} = \sum \text{Mon1}_{\text{wkst}} = 53 + 110 + 392 + 94 + 31 = 680$$

$$\text{Mon2} = \sum \text{Mon2}_{\text{wkst}} = 47 + 94 + 358 + 89 + 31 = 619$$

$$\text{Mon3} = \sum \text{Mon3}_{\text{wkst}} = 48 + 87 + 370 + 97 + 31 = 633$$

The remaining processing is for master accounts with delinquent worksite employment, as well as all single accounts with missing employment fields. Here the processing splits between seasonal single accounts and all other types. This processing is described in the Seasonal Single Employment Imputations and Other Single/Master Employment Imputations sections that follow.

Proration Factors

The initial setting of the Proration factor (the fraction of the quarter for which the account is in active status - see Selection for Imputation for details) sets an initial liability and end of liability month count value. For an account that is activated at the beginning of the second month of the quarter, the liability month count is 2 (active for the last two months of the quarter). If the account is terminated at the end of the first month of the quarter, the termination indicator is set to 1 (active for the first month of the quarter). These indicators are used in each of the monthly employment imputations, *except* for the worksite-to-master method just described (which is based upon reported data in the worksites). For months with missing month fields, each of the imputation methods to follow will be regulated by the following formula:

$$\begin{array}{l}
 \text{For Mon1 missing -} \\
 \text{If } MonCt_{Liab} > 2 \text{ And } MonCt_{Term} > 0, \\
 \text{Then } Mon1 = Imp \text{ Else } Mon1 = 0
 \end{array}
 \qquad \text{Equation J-21}$$

$$\begin{array}{l}
 \text{For Mon2 missing -} \\
 \text{If } MonCt_{Liab} > 1 \text{ And } MonCt_{Term} > 1 \\
 \text{Then } Mon2 = Imp \text{ Else } Mon2 = 0
 \end{array}
 \qquad \text{Equation J-22}$$

$$\begin{array}{l}
 \text{For Mon3 missing -} \\
 \text{If } MonCt_{Liab} > 0 \text{ And } MonCt_{Term} > 2 \\
 \text{Then } Mon3 = Imp \text{ Else } Mon3 = 0
 \end{array}
 \qquad \text{Equation J-23}$$

in which $MonCt_{Liab}$ and $MonCt_{Term}$ represent the liability and termination month counts, respectively, as described above, and Imp denotes the employment imputation value for the month. Therefore, the imputation is computed regardless of the month counts, but is only put in place within the specific employment month if the initial liability and end-of-liability dates show that the account is active during that month. Those months imputed as zero are still considered successful imputation.

Single Employment Imputations (**EMP9**)

If the maximum number of consecutive delinquent quarters had been reached, the **EMPB** imputation failure code is assigned. When the **EMPB** code is assigned, the imputation processing has been completed.

For those remaining single accounts (with recently reported data in a prior quarter), a failure can also occur if the Total Wages could not be imputed. If employment were imputed without Total Wages, a partial record would result and is therefore not acceptable. This imputation code is **EMPF**, which simply represents "employment imputation failure due to failed wage imputation attempt."

This method no longer exists in EXPO but does in WIN. Remaining accounts are checked for prior year, same quarter employment and Total Wages. If either of the prior year's fields (Total Wages or First Month Employment) is not missing, an imputation can be generated. This **EMP9** imputation method follows for each month:

$$MonX = \frac{TotW \times MonX_{cy}}{TotW_{cy} \times Prorate}
 \qquad \text{Equation J-24}$$

in which $MonX$ represents any of the three months that may be missing ($Mon1$, $Mon2$, or $Mon3$), cy denotes prior year same quarter data, and $Prorate$ indicates the proration factor, specifying the

portion of the quarter for which the account is active. Of course, this formula will not be applied to any month not conforming to the liability and termination date range as specified in the equations found in the Employment Imputation portion of this appendix. In addition, this method requires the prior year total wages and the proration factor to be non-zero. If either is zero, the imputed value is zero.

Example:

The record is in a seasonal industry and Total Wages were reported or have already been imputed.

<u>Year/Q</u>	<u>Mon1</u>	<u>Mon2</u>	<u>Mon3</u>	<u>TotW</u>
Current	Missing	Missing	Missing	4,663,218
Current, year ago	161	194	187	4,338,764
Prorate	1.000000	1.000000	1.000000	

$$\begin{aligned} \text{Mon1}_c &= (\text{TotW}_c \times \text{Mon1}_{cy}) \div (\text{TotW}_{cy} \times \text{Prorate}) \\ &= (4,663,218 \times 161) \div (4,338,764 \times 1.000000) \\ &= (750,778,098) \div (4,338,764) = 173 \end{aligned}$$

$$\begin{aligned} \text{Mon2}_c &= (\text{TotW}_c \times \text{Mon2}_{cy}) \div (\text{TotW}_{cy} \times \text{Prorate}) \\ &= (4,663,218 \times 194) \div (4,338,764 \times 1.000000) \\ &= (904,664,292) \div (4,338,764) = 209 \end{aligned}$$

$$\begin{aligned} \text{Mon3}_c &= (\text{TotW}_c \times \text{Mon3}_{cy}) \div (\text{TotW}_{cy} \times \text{Prorate}) \\ &= (4,663,218 \times 187) \div (4,338,764 \times 1.000000) \\ &= (872,021,766) \div (4,338,764) = 201 \end{aligned}$$

Seasonal Single/Master Imputations Using Macro Data (*EMP6*)

The remaining seasonal accounts are those that have no employment or Total Wages from the prior year. For these records, macro year-ago data reflecting the same cell (the same county, ownership and NAICS code) are used. If macro data do not exist for the cell, the *EMPC* imputation failure code is assigned (imputation not possible since macro record is non-existent). If the record exists, the prior year employment and Total Wages are checked for zeroes. If either are zero, an imputation is not made and the *EMPD* imputation failure code is assigned (not estimated due to insufficient macro data).

If the macro cell employment and Total Wage values are greater than zero, the state system successfully applies the following *EMP6* imputation technique:

$$MonX_c = \frac{(Mon1_{Mac_{cy}} + Mon2_{Mac_{cy}} + Mon3_{Mac_{cy}}) \times TotW_c}{TotW_{Mac_{cy}} \times 3 \times Prorate} \quad \text{Equation J-25}$$

in which $MonX_c$ represents any of the three months that are missing, Mac identifies macro-level data, cy specifies the prior year's same quarter data, and $Prorate$ denotes the quarter proration factor (the fraction of the quarter for which the account is active).

Example:

The record is in a seasonal industry and Total Wages were reported or have already been imputed. Macro data are used since the record's own year ago data are not available. All three months of employment are missing.

<u>Year/Q</u>	<u>Mon1_{Maccy}</u>	<u>Mon2_{Maccy}</u>	<u>Mon3_{Maccy}</u>	<u>TotW_{Maccy}</u>	<u>TotW</u>
Current	–	–	–	–	4,663,218
Current, year ago	461	494	487	9,338,764	–
Prorate	1.000000	1.000000	1.000000		

$$\begin{aligned} MonX &= Mon1 = Mon2 = Mon3 = \\ &= ((Mon1_{Maccy} + Mon2_{Maccy} + Mon3_{Maccy}) \times TotW) \div (TotW_{Maccy} \times 3 \times Prorate) \\ &= ((461 + 494 + 487) \times 4,663,218) \div (9,338,764 \times 3 \times 1.000000) \\ &= (1,442 \times 4,663,218) \div (28,016,292) \\ &= (6,724,360,356) \div (28,016,292) \\ &= 240 \end{aligned}$$

Other Single/Master Employment Imputations

Non-seasonal accounts are also checked to see if the maximum allowable imputations have already been reached. If so, the **EMPB** (insufficient data) failure code is assigned, and all missing employment months remain missing.

Non-seasonal accounts also require previous quarter employment to generate a current quarter imputation. If the previous quarter shows an inactive status, but the current quarter's Total Wages are greater than zero, a macro-based estimate is generated (the same as that described above in the seasonal account imputation process. Failure codes (**EMPC** and **EMPD**) and the success code (**EMP6**) are the same as those detailed above.

Employment Ratio Imputations (EMP3)

If the record was active in the prior quarter, the state system identifies how many months of prior quarter employment are available. If all of the three prior year employment months are positive, the standard **EMP3** imputation method is used. This method cannot be used for prior quarter imputations because the prior year, prior quarter's third month employment is not available. Each missing month is treated separately. Month 1 Employment (January, April, July or October) is estimated using the following equations:

$$\text{Ratio} = \frac{\text{Mon } 1_{cy}}{\text{Mon } 3_{py}} \quad \text{Equation J-26}$$

*If Ratio > Inc_{Max} or Ratio < Dec_{Max}
Then Set Ratio to Limit*

$$\text{Mon } 1 = \text{Mon } 3_p \times \text{Ratio} \quad \text{Equation J-27}$$

in which Inc_{Max} and Dec_{Max} are the greatest increase and decrease allowed. See Total Wage Ratio Imputation (TOT2) for additional information on the ratios. The p subscript specifies the prior quarter's value, whereas the cy and py values represent the prior-year same-quarter and prior-year prior-quarter values, respectively. These equations are used only when the first month's employment value is missing, and the record was active for that month.

The equations for Month 2 Employment (February, May, August or November) of the quarter are listed below:

$$\text{Ratio} = \frac{\text{Mon } 2_{cy}}{\text{Mon } 1_{cy}} \quad \text{Equation J-28}$$

*If Ratio > Inc_{Max} or Ratio < Dec_{Max}
Then Set Ratio to Limit*

$$\text{Mon } 2 = \text{Mon } 1 \times \text{Ratio} \quad \text{Equation J-29}$$

where Inc_{Max} and Dec_{Max} again specify the ratio range for employment change. See Total Wage Ratio Imputation (TOT2) for additional information on the ratios. cy represents the prior-year same-quarter value. This second month imputation is only conducted for accounts that are active during the second employment month and are missing this field.

The Month 3 Employment (March, June, September or December) are imputed using the following formulae:

$$\text{Ratio} = \frac{\text{Mon } 3_{cy}}{\text{Mon } 2_{cy}}$$

Equation J-30

If $\text{Ratio} > \text{Inc}_{\text{Max}}$ or $\text{Ratio} < \text{Dec}_{\text{Max}}$
Then Set Ratio to Limit

$$\text{Mon}3 = \text{Mon}2 \times \text{Ratio}$$

Equation J-31

Once again the Inc_{Max} , Dec_{Max} , and cy values were previously defined.

Example:

The record is in a non-seasonal industry and year ago data and prior quarter data are available.

<u>Year/Q</u>		<u>Mon1</u>	<u>Mon2</u>	<u>Mon3</u>
Current Quarter		Missing	Missing	Missing
Prior Quarter,	p	87	81	83
same year				
Current Quarter,	cy	72	75	98
year ago				
Prior Quarter,	py	61	59	68
year ago				

$$\text{Inc}_{\text{Max}} = 1 + (25/100) = 1.25$$

$$\text{Dec}_{\text{Max}} = 1 - (20/100) = .80$$

Mon1:

$$\begin{aligned} \text{Ratio} &= (\text{Mon}1_{cy} \div \text{Mon}3_{py}) \\ &= 72 \div 68 = 1.058823 \end{aligned}$$

$$\begin{aligned} \text{Mon}1 &= \text{Mon}3_p \times \text{Ratio} \\ &= 83 \times 1.058823 \\ &= 88 \end{aligned}$$

Mon2:

$$\begin{aligned}\text{Ratio} &= (\text{Mon2}_{\text{cy}} \div \text{Mon1}_{\text{cy}}) \\ &= 75 \div 72 = 1.041667\end{aligned}$$

$$\begin{aligned}\text{Mon2} &= \text{Mon1} \times \text{Ratio} \\ &= 88 \times 1.041667 \\ &= 92\end{aligned}$$

Mon3:

$$\begin{aligned}\text{Ratio} &= (\text{Mon3}_{\text{cy}} \div \text{Mon2}_{\text{cy}}) \\ &= 98 \div 75 = 1.306667\end{aligned}$$

Ratio = 1.306667 > 1.25; therefore Ratio = 1.25

$$\begin{aligned}\text{Mon3} &= \text{Mon2} \times \text{Ratio} \\ &= 92 \times 1.25 \\ &= 115\end{aligned}$$

Prior Quarter Imputations (*EMP4*)

The remaining single records to impute were active in the prior quarter, but did not have employment greater than zero in all three months in the previous year. If Third Month Employment in the prior quarter is greater than zero, use the following *EMP4* employment imputation formulae:

$$\text{MonX} = \text{Mon3}_p \times \frac{\text{TotW}}{\text{TotW}_p \times \text{Prorate}} \quad \text{Equation J-32}$$

$$\text{If } \frac{\text{TotW}}{\text{TotW}_p \times \text{Prorate}} < \text{Dec}_{\text{Max}}, \text{ MonX} = \text{Mon3}_p \times \text{Dec}_{\text{Max}} \quad \text{Equation J-33}$$

$$\text{If } \frac{\text{TotW}}{\text{TotW}_p \times \text{Prorate}} > \text{Inc}_{\text{Max}}, \text{ MonX} = \text{Mon3}_p \times \text{Inc}_{\text{Max}}$$

$$\text{If } \text{TotW}_p = 0, \text{ MonX} = \text{Mon3}_p$$

MonX denotes any month in the quarter with missing employment (if the record is active during that month), *p* represents prior quarter data, *Dec_{Max}* and *Inc_{Max}* form the lower and upper limits for the monthly employment change, and *Prorate* is a proration factor for the fraction of the quarter during which the account is active.

Example:

The record is in a non-seasonal industry but year-ago data are not available. Third Month Employment in the prior quarter is greater than zero. All three months of the current quarter are missing.

<u>Year/Q</u>		<u>Mon1</u>	<u>Mon2</u>	<u>Mon3</u>	<u>TotW</u>
Current Quarter		Missing	Missing	Missing	699,009
Prior Quarter, same year	p	87	81	83	608,283

$$\text{Prorate} = 1.000000$$

$$\text{Inc}_{\text{Max}} = 1 + (25/100) = 1.25$$

$$\text{Dec}_{\text{Max}} = 1 - (20/100) = .80$$

$$\text{MonX} = \text{Mon3}_p \times (\text{TotW} \div (\text{TotW}_p \times \text{Prorate}))$$

$$\begin{aligned} (\text{TotW} \div (\text{TotW}_p \times \text{Prorate})) &= 699,009 \div (608,283 \times 1.000000) \\ &= 1.14915 \end{aligned}$$

1.14915 is greater than 0.80 and is less than 1.25

$$\begin{aligned} \text{MonX} &= \text{Mon3}_p \times (\text{TotW} \div (\text{TotW}_p \times \text{Prorate})) \\ &= 83 \times 1.14915 \\ &= 95 \end{aligned}$$

Prior Quarter AME Imputations (*EMP5*)

The remaining single and master records are those that were active in the prior quarter but had zero employment in the third month of that quarter. Year ago data are not available. This *EMP5* method uses non-zero prior quarter's *AME* (average monthly employment) where the formula follows:

$$AME_p = \frac{\text{Mon } 1_p + \text{Mon } 2_p + \text{Mon } 3_p}{3} \quad \text{Equation J-34}$$

$$\text{MonX} = AME_p \times \frac{\text{TotW}}{\text{TotW}_p \times \text{Prorate}} \quad \text{Equation J-35}$$

$$\text{If } \frac{\text{TotW}}{\text{TotW}_p \times \text{Prorate}} < \text{Dec}_{\text{Max}}, \text{ MonX} = AME_p \times \text{Dec}_{\text{Max}}$$

$$\text{If } \frac{\text{TotW}}{\text{TotW}_p \times \text{Prorate}} > \text{Inc}_{\text{Max}}, \text{ MonX} = AME_p \times \text{Inc}_{\text{Max}}$$

$$\text{If } \text{TotW}_p = 0, \text{ MonX} = AME_p$$

where *MonX* is any missing employment month, *p* represents prior quarter data, *Dec_{Max}* and *Inc_{Max}* bound the change in employment from the prior quarter's *AME* value to the processed quarter's employment, and *Prorate* identifies the proration factor (the fraction of the quarter for which the account is active).

Example:

The record is in a non-seasonal industry but year-ago data are not available. Third Month Employment in the prior quarter is greater than zero. All three months of the current quarter are missing.

<u>Year/Q</u>		<u>Mon1</u>	<u>Mon2</u>	<u>Mon3</u>	<u>TotW</u>
Current Quarter		Missing	Missing	Missing	699,009
Prior Quarter, same year	p	87	81	0	608,283

$$\text{Prorate} = 1.000000$$

$$\text{Inc}_{\text{Max}} = 1 + (25/100) = 1.25$$

$$\text{Dec}_{\text{Max}} = 1 - (20/100) = .80$$

$$\begin{aligned} \text{AME}_p &= (\text{Mon1}_p + \text{Mon2}_p + \text{Mon3}_p) \div 3 \\ &= (87 + 81 + 0) \div 3 \\ &= 168 \div 3 = 56 \end{aligned}$$

$$\text{MonX} = \text{AME}_p \times (\text{TotW} \div (\text{TotW}_p \times \text{Prorate}))$$

$$\begin{aligned} (\text{TotW} \div (\text{TotW}_p \times \text{Prorate})) &= 699,009 \div (608,283 \times 1.000000) \\ &= 1.14915 \end{aligned}$$

1.14915 is greater than 0.80 and is less than 1.25

$$\begin{aligned} \text{MonX} &= \text{AME}_p \times (\text{TotW} \div (\text{TotW}_p \times \text{Prorate})) \\ &= 56 \times 1.14915 \\ &= 64 \end{aligned}$$

Single/Master Imputation Using Macro Data (*EMP6*)

If the record's prior quarter AME equals zero, the state system looks for macro data in the same industry, county, and ownership. If the cell does not exist, then the *EMPC* imputation failure code is assigned (imputation not possible since Macro record is non-existent). If the macro record is found, but either the employment or Total Wages equal zero, then the *EMPD* imputation failure code is assigned (not imputed due to insufficient macro data). If non-zero macro data are available, then a successful imputation is generated using the following *EMP6* imputation formula:

$$\text{MonX} = \frac{(\text{Mon } 1_{\text{Mac}_{cy}} + \text{Mon } 2_{\text{Mac}_{cy}} + \text{Mon } 3_{\text{Mac}_{cy}}) \times \text{TotW}}{\text{TotW}_{\text{Mac}_{cy}} \times 3 \times \text{Prorate}}$$

Equation J-36

in which $MonX$ represents any of the three months that are missing, Mac identifies macro-level data, cy specifies the prior year's same quarter data, and $Prorate$ denotes the quarter proration factor (the fraction of the quarter for which the account is active).

See Seasonal Single/Master Imputations Using Macro Data (EMP6) for an example of this formula.

Worksite Employment Estimates (EMP7/EMP8)

If all units on the MWR in the multi are missing employment and the master record data are available, either reported or imputed, then the worksite employment can be imputed.

If some (but not all) of the worksites that compose the multi account have reported employment data, the remaining worksites (with missing data) should be prorated if the difference between the sum of reported worksite data from the master record employment is greater than zero. If it is zero or less, then those worksites which show missing data are treated like they were zero reporters and are assigned a successful imputation code of **EMP8**.

If the master record was not reported and could not be imputed, the worksite can not be imputed either and an imputation failure code of **EMPE** is assigned.

The other potential failure occurs when the master does not have prior quarter employment. If the master's prior quarter Third Month Employment equals zero, the prior quarter worksite-to-master employment ratio is undefined. This causes the worksite employment distribution to fail with a code of **EMPG** (could not impute employment due to absence of prior quarter data).

The successful worksite employment distribution occurs if none of the preceding conditions occurred. This **EMP7** imputation method using the following equations:

$$Mon1 = \frac{Mon1_{cs} \times Mon3_p}{Mon3_{ps}} \quad \text{Equation J-37}$$

$$Mon2 = \frac{Mon2_{cs} \times Mon1}{Mon1_{cs}} \quad \text{Equation J-38}$$

$$Mon3 = \frac{Mon3_{cs} \times Mon2}{Mon2_{cs}} \quad \text{Equation J-39}$$

cs identifies master account data (reduced by applied worksite estimates), ps signifies the prior quarter's summed worksite data (decreased by processed worksite values) and p stands for worksite's prior quarter employment value.

The initial liability and end of liability dates are checked. The record must be active throughout the entire quarter. If it was not active during any month, then no month will be imputed. Either all three months can be imputed for the worksites, or no employment can be imputed.

As imputations are generated, the *cs* and *ps* subscripted fields are adjusted, according to the following equations:

$$Mon\ 3_{psadjusted} = Mon\ 3_{ps} - Mon\ 3_p \qquad \text{Equation J-40}$$

$$Mon\ 1_{csadjusted} = Mon\ 1_{cs} - Mon\ 1 \qquad \text{Equation J-41}$$

$$Mon\ 2_{csadjusted} = Mon\ 2_{cs} - Mon\ 2 \qquad \text{Equation J-42}$$

$$Mon\ 3_{cs\ adjusted} = Mon\ 3_{cs} - Mon\ 3 \qquad \text{Equation J-43}$$

in which the *p*-subscripted Mon3 is the worksite’s prior quarter third month employment, and the Mon1, Mon2 and Mon3 values (subtracted from each of the *ps*-subscripted fields) are the worksite’s just-imputed monthly employment for the current quarter. The remaining employment provides a new month-to-month ratio for the next worksite employment imputation that can vary to a minute degree from the original ratio.

Note: The summed third month’s employment value excludes all worksites that were inactivated during the previous quarter. If these inactivated worksites were left in the process, the current quarter estimates would be low by the final employment in the terminated worksites, resulting in an out-of-balance situation.

Employment Proration Example:

The following demonstrates the methods used in the imputation of employment for delinquent worksites. The multi had reported employment, both for worksites and the master account, in the prior quarter. There were eight worksites in the multi, but reporting unit #00007 was closed at the end of the prior quarter. The current quarter master account employment has been reported, but the worksites require imputation. The following table summarizes the known and unknown data for the multi.

Reporting Unit No.	Month 3 p	Month1 c	Month 2 c	Month 3 c
00000	72	57	58	63
00001	7	?	?	?
00003	3	?	?	?
00004	14	?	?	?
00005	5	?	?	?

Reporting Unit No.	Month 3 p	Month1 c	Month 2 c	Month 3 c
00007 – inactivated	26	0	0	0
00008	4	?	?	?
00011	10	?	?	?
00012	6	?	?	?
Worksite Sum	(75 w/ inactive unit) 49	?	?	?

The master account’s third month prior quarter employment (72) disagrees with the worksite sum for the same month (75 when the inactive worksite is included; it is even farther off when the inactive worksite is removed (49 versus 72)). However, the worksite sum is used for the prior quarter rather than the master account’s value. So the initial ratios for month-to-month employment become 57/49 (Mon1_c/Mon3_p), 58/57 (Mon2/Mon1) and 63/58 (Mon3/Mon2). These are applied to RUN #00001’s prior quarter third month employment (7) and rounded to give the imputed First Month Employment, found from

$$\text{Mon1}_{\text{RUN1}} = \text{Mon3}_{\text{p RUN1}} \times \text{Mon1}_{\text{cs}} / \text{Mon3}_{\text{ps}}$$

$$= 7 \times 57 / 49 = 8.1429... \rightarrow 8 \text{ (rounded)}$$

from which the second and third employment months can be imputed. Mon2 is found by multiplying the first month estimate (8) by the Mon2/Mon1 imputation ratio (58/57), for a rounded value of **8** (from 8.140...); the third month is determined by using the estimated second month (8) times the Mon3/Mon2 imputation ratio (63/58) which also rounds to **9** (from 8.6897). Because of the rounding, the precise summed level ratio cannot be maintained for all worksites, unless cumulative rounding is used. Hence the need for realigning the ratio based on the estimates computed thus far.

The three imputed monthly employment values (8, 8, and 9, respectively,) are subtracted from what had been the master account’s monthly employment, leaving **49**, **50** and **54**, respectively. The worksite’s prior quarter third month employment is deducted from the *pqs* sum to give a new value of **42**. The process is then repeated on each of the other worksites (excluding the inactivated reporting unit #00007) using the revised employment sum values. The table below demonstrates how this works.

RUN→	00001	00003	00004	00005	00007	00008	00011	00012
M3 ps	49	42	39	25	20	20	16	6
M1 cs	57	49	45	29	23	23	18	7
M2 cs	58	50	46	30	24	24	19	7

RUN→	00001	00003	00004	00005	00007	00008	00011	00012
M3 cs	63	54	50	33	26	26	21	8
Ratio 1	1.163	1.167	1.154	1.160	1.150	1.150	1.125	1.167
Ratio 2	1.018	1.020	1.022	1.034	1.043	1.043	1.056	1.000
Ratio 3	1.086	1.080	1.087	1.100	1.083	1.083	1.105	1.143
M3 p	7	3	14	5	26	4	10	6
Mon1	8	4	16	6	0	5	11	7
Mon2	8	4	16	6	0	5	12	7
Mon3	9	4	17	7	0	5	13	8

The above table shows the figures involved in preparing the imputations (the last three rows) for each of the worksites. The first row under the Reporting Unit Numbers is the summed prior quarter third month employment with any already-processed worksites' inclusion in this sum removed from the total (subtracting the "M3 p" value before the next "M3 ps" value is displayed). The next three rows are initially the employment fields from the master account, but these have any already-enacted imputations removed from the equivalent fields in the bottom three rows. The three rows labeled "Ratio 1", "Ratio 2", and "Ratio 3" are the results of dividing M1cs/M3ps, M2cs/ M1cs, and M3cs/M2cs, respectively. These form another version of the equations already described, so that the ratios form two-part equations, namely:

$$\begin{aligned}\text{Ratio1} &= \text{Mon1}_{cs} \div \text{Mon3}_{ps} \\ \text{Mon1} &= \text{Mon3}_p \times \text{Ratio1}\end{aligned}$$

$$\begin{aligned}\text{Ratio2} &= \text{Mon2}_{cs} \div \text{Mon1}_{cs} \\ \text{Mon2} &= \text{Mon1} \times \text{Ratio2}\end{aligned}$$

$$\begin{aligned}\text{Ratio3} &= \text{Mon3}_{cs} \div \text{Mon2}_{cs} \\ \text{Mon3} &= \text{Mon2} \times \text{Ratio3}\end{aligned}$$

EXPO also allows the option of online seasonal proration. Employment is prorated in the same manner as non-seasonal prorations except instead of using third month employment of the prior quarter,

- Month one of the same quarter, year ago is used for month one
- Month two of the same quarter, year ago is used for month two
- Month three of the same quarter, year ago is used for month three

as the denominator of the ratio:

$$\text{Ratio1}_{\text{seas}} = \text{Mon1}_{\text{cs}} \div \text{Mon1}_{\text{cys}}$$
$$\text{Mon1} = \text{Mon1}_{\text{cy}} \times \text{Ratio}_{\text{seas}}$$

$$\text{Ratio2}_{\text{seas}} = \text{Mon2}_{\text{cs}} \div \text{Mon2}_{\text{cys}}$$
$$\text{Mon2} = \text{Mon2}_{\text{cy}} \times \text{Ratio2}_{\text{seas}}$$

$$\text{Ratio3}_{\text{seas}} = \text{Mon3}_{\text{cs}} \div \text{Mon3}_{\text{cys}}$$
$$\text{Mon3} = \text{Mon3}_{\text{cy}} \times \text{Ratio3}_{\text{seas}}$$

to project employment forward.

Imputation Report Code Settings and Indicator Flags

The three lists that follow identify successful imputation codes, imputation failure codes, and the indicator flags for employment, total wages, taxable wages, and contributions.

**Imputation Report Codes:
Successful Imputation Codes**

Code	Description
TOT1	TotW(c) = SUMMATION OF WORKSITES' TotW(c)
TOT2	TotW(c) = TotW(p)*(TotW(cy)/TotW(py))
TOT3	TotW(c) = TotW(p) (Seasonal accounts only)
TOT4	TotW(c) = TotW(p)
TOT5	TotW(c) = MASTER TotW(c)* (WORKSITE TotW(p)/MASTER TotW(p))
TOT6	WORKSITE TotW NOT IMPUTED (LEFT MISSING)
TOT8	TotW(c) = TotW(p)* MACRO (TotW(cy)/TotW(py))
TOT9	TotW(c) = AME(c)*MACRO (TotW(cy)/AME(cy))
TAX1	TaxW(c) = TotW(c)* (TaxW(cy)/TotW(cy))
TAX2	TaxW(c) = TotW(c)* (TaxW/TotW RATIO FROM MACRO FILE)
TAX3	TaxW(c) = TotW(c) * (MASTER TaxW(c)/MASTER TotW(c))
TAX4	TaxW(c) = Ctrb(c) = 0, BECAUSE MASTER TotW(c) = 0
CTB1	Ctrb(c) = TAXABLE WAGES(c) * ACCOUNT'S TAX RATE
EMP2	EMPLOYMENT(c) = SUM OF WORKSITES' EMPLOYMENT(c)
EMP3	Mon1(c) = Mon3(p) * (Mon1(cy)/Mon3(py)) Mon2(c) = Mon1(c) * (Mon2(cy)/Mon(cy)) Mon3(c) = Mon2(c) * (Mon3(cy)/Mon2(cy))
EMP4	Mon1(c) = Mon2(c) = Mon3(c) = EMPLOYMENT(c) = Mon3(p) * TotW(c)/TotW(p)
EMP5	Mon1(c) = Mon2(c) = Mon3(c) = EMPLOYMENT(c) = AME(p)*TOTAL WAGES(c)/TOTAL WAGES(p)
EMP6	Mon1(c) = Mon2(c) = Mon3(c) = EMPLOYMENT(c) = TOTAL WAGES(c)* (EMPLOYMENT/TOTAL WAGES RATIO FROM MACRO FILE)/3
EMP7	Mon1(c) = Mon2(c) = Mon3(c) = EMPLOYMENT(c) = MASTER EMPLOYMENT(c)* (WORKSITE MONTH3(p)/MASTER MONTH3(p))

**Imputation Report Codes:
Successful Imputation Codes**

<i>Code</i>	<i>Description</i>
EMP8	Mon1(c) = Mon2(c) = Mon3(c), WORKSITE EMPLOYMENT NOT ESTIMATED (LEFT MISSING).
EMP9	Mon1(c) = Mon2(c) = Mon3(c) = EMPLOYMENT(c) = EMPLOYMENT(5) * TOTAL WAGES(c)/TOTAL WAGES(cy)

**Imputation Report Codes:
Imputation Failure Codes**

<i>Code</i>	<i>Description</i>
TOTA	TOTAL WAGES not imputed because TOTAL WAGES(p) are missing.
TOTB	TOTAL WAGES not imputed because TOTAL WAGES(cy) are missing (seasonal account).
TOTC	TOTAL WAGES, TAXABLE WAGES, CONTRIBUTIONS not imputed because master TOTAL WAGES(p) are missing.
TOTD	TOTAL WAGES are not imputed because master account had imputation error.
TOTE	TOTAL WAGES not imputed because macro data are 0.
TAXA	TAXABLE WAGES not imputed because TOTAL WAGES(cy) = 0, CTY-OWN-NAICS group not found on MACRO FILE.
TAXB	TAXABLE WAGES not imputed because TOTAL WAGES(cy) = 0, MACRO FILE TOTAL WAGES = 0
TAXC	TAXABLE WAGES not imputed because master account had imputation error.
EMPB	EMPLOYMENT no imputed because EMPLOYMENT(p) is missing due to prior quarter(s) delinquency.
EMPC	EMPLOYMENT not imputed because COUNTY-OWNER-NAICS group not found on MACRO FILE.
EMPD	EMPLOYMENT not imputed because MACRO FILE EMPLOYMENT = 0.
EMPE	EMPLOYMENT not imputed because master account EMPLOYMENT had imputation error.

**Imputation Report Codes:
Imputation Failure Codes****Code Description****EMPF** EMPLOYMENT not imputed because no employment formula is available.**EMPG** EMPLOYMENT not imputed because master account MONTH3(p) = 0.

Code	Meaning	Indicator Flags	For Data Field(s)
Blank or R	Reported data.		EMPL, TW, TAX, CTB.
A	Estimated/imputed using data reported to the CES program.		EMPL.
C	Changed (re-reported).		EMPL, TW, TAX, CTB.
D	Reported from missing data notice.		EMPL.
E	Estimated/imputed single unit data. Imputed worksite data prorated from <i>imputed</i> parent/master record.		EMPL, TW, TAX, CTB.
H	Hand-imputed (vs. system generated).		EMPL, TW, TAX, CTB.
K	Special system-generated imputation emulating data impacted by a catastrophe		EMPL, TW, TAX, CTB.
L	Late reported (overrides prior imputation).		EMPL, TW, TAX, CTB.
M	Missing data.		EMPL, TW, TAX, CTB.
N	Zero-filled, pending resolution of long-term delinquent reporter		EMPL, TW, TAX, CTB.
P	Prorated from <i>reported</i> parent/master to sub-unit/worksite.		EMPL, TW, TAX, CTB.
S	Aggregated parent/master from reported MWR or EDI data.		EMPL, TW.
W	Estimated/imputed using data <i>reported</i> on quarterly wage records		EMPL, TW.
X	Non-numeric data zero-filled pending further action.		EMPL, TW, TAX, CTB.

Appendix K – EQUI File Layout

Every Enhanced Quarterly Unemployment Insurance (EQUI) file generated by the state processing systems consists of one header record, one trailer record, and as many data records as are needed to provide initial or updated micro data to the national office. The record length of each EQUI record is 1190 positions. The blocksize of the EQUI file is 27,370. The following EQUI file layout has been effective since 2006/2.

EQUI Data Record

The normal data record provides all data elements available on the state system for the specified Unemployment Insurance (UI) Account Number/Reporting Unit Number (RUN) for that year and quarter. A delete record is a special type of data record that removes all data for the specified UI/RUN for all years and quarters. Appendix B defines the data elements.

Start	End	Length	Field Type	Data Element
1	1	1	Adm	Transaction Code
2	3	2	Adm	State FIPS Numeric Code
4	7	4	Qtr	Year
8	8	1	Qtr	Quarter
9	18	10	Adm	UI Account Number
19	23	5	Adm	Reporting Unit Number
24	32	9	Adm	EIN (Employer Identification Number)
33	42	10	—	Filler
43	47	5	—	Filler
48	57	10	—	Filler
58	62	5	—	Filler
63	97	35	Adm	Legal/Corporate Name
98	132	35	Adm	Trade Name/DBA
				<i>UI Address Block (133-243)</i>
133	167	35	Adm	UI Street Address--Line 1
168	202	35	Adm	UI Street Address--Line 2
203	232	30	Adm	UI Address—City
233	234	2	Adm	UI Address—State
235	239	5	Adm	UI Address--5-Digit ZIP Code
240	243	4	Adm	UI Address--ZIP Code Extension
				<i>Physical Location Address Block (244-354)</i>
244	278	35	Adm	Physical Location (PLA) Street Address--Line 1
279	313	35	Adm	Physical Location (PLA) Street Address--Line 2
314	343	30	Adm	Physical Location Address (PLA)--City

Start	End	Length	Field Type	Data Element
344	345	2	Adm	Physical Location Address (PLA)--State
346	350	5	Adm	Physical Location Address (PLA)--5-Digit ZIP Code
351	354	4	Adm	Physical Location Address (PLA)--ZIP Code Extension
				<i>Mailing/Other Address Block (355-466)</i>
355	389	35	Adm	Mailing/Other (MOA) Street Address--Line 1
390	424	35	Adm	Mailing/Other (MOA) Street Address--Line 2
425	454	30	Adm	Mailing/Other (MOA) Address--City
455	456	2	Adm	Mailing/Other (MOA) Address--State
457	461	5	Adm	Mailing/Other (MOA) Address--5-Digit ZIP Code
462	465	4	Adm	Mailing/Other (MOA) Address--ZIP Code Extension
466	466	1	Adm	Mailing/Other (MOA) Address Type
467	501	35	Adm	Reporting Unit Description
				<i>Telephone Number (502-511)</i>
502	504	3	Adm	Phone Area Code
505	507	3	Adm	Phone Prefix
508	511	4	Adm	Phone Suffix
				<i>Setup Date (512-519)</i>
512	515	4	Adm	Setup Date—Year
516	517	2	Adm	Setup Date—Month
518	519	2	Adm	Setup Date—Day
				<i>Initial Date of Liability (520-527)</i>
520	523	4	Adm	Initial Date of Liability--Year
524	525	2	Adm	Initial Date of Liability--Month
526	527	2	Adm	Initial Date of Liability--Day
				<i>End of Liability Date (528-535)</i>
528	531	4	Adm	End of Liability Date—Year
532	533	2	Adm	End of Liability Date—Month
534	535	2	Adm	End of Liability Date—Day
				<i>Reactivation Date (536-543)</i>
536	539	4	Adm	Reactivation Date--Year
540	541	2	Adm	Reactivation Date--Month
542	543	2	Adm	Reactivation Date--Day
544	544	1	Qtr	Status Code
545	545	1	Adm	CES Indicator
546	547	2	Adm	ARS Response Code

Start	End	Length	Field Type	Data Element
548	551	4	Adm	ARS Refile Year
552	554	3	Adm	Old County Code
555	555	1	Adm	Old Ownership Code
556	559	4	Adm	ARS Verification Year
560	562	3	Adm	Old Township Code
563	567	5	Adm	Maximum Reporting Unit Number
568	568	1	Adm	MWR Mail Indicator
569	574	6	Adm	Old NAICS Code
575	575	1	Qtr	Data Source
576	576	1	Adm	Special Indicator Code
577	580	4	Qtr	Agent Code
581	584	4	Qtr	SIC
585	590	6	Qtr	NAICS12 Code (previously NAICS07)
591	596	6	Qtr	NAICS Code
597	597	1	Qtr	Ownership Code
598	598	1	Adm	Organization Type Code
599	601	3	Qtr	County Code
602	604	3	Qtr	Township Code
605	605	1	—	Filler
606	611	6	Qtr	First Month Employment
612	612	1	Qtr	First Month Employment Indicator
613	618	6	Qtr	Second Month Employment
619	619	1	Qtr	Second Month Employment Indicator
620	625	6	Qtr	Third Month Employment
626	626	1	Qtr	Third Month Employment Indicator
627	637	11	Qtr	Total Wages
638	638	1	Qtr	Total Wages Indicator
639	649	11	Qtr	Taxable Wages
650	658	9	Qtr	Contributions (Due)
659	659	1	Qtr	Type of Coverage Code
660	660	1	Qtr	MEEI Code
661	661	1	Adm	PLA Type Code
662	663	2	Qtr	First Comment Code
664	665	2	Qtr	Second Comment Code
666	667	2	Qtr	Third Comment Code
668	724	57	Qtr	Narrative Comment
725	726	2	Adm	Collection Mode Indicator
727	728	2	Qtr	ECCI
729	729	1	Adm	UI Address Type Code
730	737	8	Adm	Date PLA Changed
738	738	1	Adm	Geocoding Software
739	739	1	Adm	Geocoding Source
740	743	4	Adm	Match Code

Start	End	Length	Field Type	Data Element
744	746	3	Twice	Location Code
747	755	9	Twice	Latitude
756	766	11	Twice	Longitude
767	771	5	Twice	Year and Quarter of New Latitude and Longitude
772	776	5	Qtr	Place Code
777	778	2	Qtr	Class Code
779	793	15	Qtr	Census ID: 2 digit State code 3 digit County code 6 digit Census Tract 1 digit Census Block Group 2 digit Census Block Code 1 digit optional Block Code letter
794	797	4	—	Filler
798	798	1	Adm	Address Source Code
				<i>Nondisclosure/Informed Consent (799-807)</i>
799	799	1	Adm	Nondisclosure/Informed Consent Code
800	803	4	Adm	Nondisclosure/Informed Consent Year Agreed
804	807	4	Adm	Nondisclosure/Informed Consent Year Ended
				<i>Future QCEW Contact Block (808-827)</i>
808	811	4	Adm	Future ARS Refile Year
812	813	2	Adm	Future ARS Response Code
814	819	6	Adm	Future NAICS Code
820	822	3	Adm	Future County Code
823	825	3	Adm	Future Town Code
826	827	2	Adm	Future CMI Code
				<i>Wage Record Summary Information (828-844)</i>
828	833	6	Qtr	Wage Record Count of Unique SSNs
834	844	11	Qtr	Wage Record Wages
845	849	5	Adm	Phone Extension
				<i>QCEW Contact Block (850-1049)</i>
850	884	35	Adm	QCEW Contact (Attention Line)
885	919	35	Adm	QCEW Contact Title
920	979	60	Adm	QCEW Contact Email Address
980	989	10	Adm	QCEW Contact Fax
990	1049	60	Adm	Website Address
1050	1050	1	—	Future Use

Start	End	Length	Field Type	Data Element
1051	1060	10	Qtr	Largest Wage Record Receptient—Possible or Actual Successor
1061	1066	6	Qtr	Wage Record Count to Largest Wage Record Receptient
1067	1076	10	Qtr	Largest Wage Record Contributor—Possible or Actual Predecessor
1077	1082	6	Qtr	Wage Record Count from Largest Wage Record Contributor
1083	1088	6	Qtr	Hires
1089	1094	6	Qtr	Separations
1095	1100	6	Qtr	"New Entrants"
1101	1106	6	Qtr	"Exits"
1107	1112	6	Qtr	"Continuous Employees"
				<i>Discrepancy Information (1113-1190)</i>
1113	1116	4	Adm	Fact of Discrepancy Year
1117	1118	2	Adm	Fact of Discrepancy Month
1119	1120	2	Adm	Fact of Discrepancy Control/Action Code
1121	1126	6	Adm	Fact of Discrepancy NAICS
1127	1129	3	Adm	Fact of Discrepancy County
1130	1186	57	Adm	Fact of Discrepancy Explanation
1187	1190	4	—	Filler/Future Field

Predecessor/Successor Supplemental Records

Predecessor/Successor supplemental records provide detailed information about the relationship between a predecessor and its successor. A pred/succ supplemental record is generated for each EQUI data record with a comment code of 85, 86, 87, 92, or 93. This means that for each identified pred/succ relationship (or pair), two pred/succ records are generated: one for the predecessor and one for the successor.

Start	End	Len	Data Element
1	1	1	Transaction Code where the value is set to "P"
2	3	2	State FIPS Numeric Code
4	13	10	UI Account Number
14	18	5	Reporting Unit Number
19	19	1	Format Type
20	20	1	Action Code
21	30	10	Predecessor or Successor UI Account Number
31	35	5	Predecessor or Successor Reporting Unit Number
36	37	2	P/S Source Code
38	45	8	P/S Transfer Date
46	53	8	P/S Posting Date
54	198	145	P/S Narrative Comment

EQUI Header Record

The header record, whose file layout is shown below, provides the parameter values used by the state. For each parm on the header record, the table shows the edit or edits that use the parm, as well as the default value for that parm in state systems. The edit conditions and formulas are described in detail in Appendix F.

Positions	Data Element	Length	State Default Value	Parameter or Tolerance Name	Edit Code
1	Transaction Code	1	(Always "H")		
2-3	State FIPS Code	2			
4-7	Year	4			
8	Quarter	1			
9-18	UI Account Number	10	zero-filled		
19-23	Reporting Unit Number	5	zero-filled		
<i>Creation Date and Time (24-39)</i>					
24-27	Creation Year	4			
28-29	Creation Month	2			
30-31	Creation Day	2			
32-33	Creation Hour	2			
34-35	Creation Minutes	2			
36-37	Creation Seconds	2			
38-39	Creation 100ths Seconds	2			
40-42	Record Length	3	724		
43-47	Block Size	5	31856		
<i>Edit Parmes (48-433)</i>					
48-53	Tax Rate Range	6	15000	Maximum Tax Rate	047
54-59	Tax Rate Range	6	0	Minimum Tax Rate	047
60-65	Contributions > Taxable Wages	6	0	Employee Tax Rate	063, 118
66-71	Predecessor/ Successor Format	6	0	Predecessor and Successor AME Cutoff	066-067
72-73	Monthly Employment Change	2	20	Split Level for Employment Difference Check	091, 126 micro/macro

Positions	Data Element	Length	State Default Value	Parameter or Tolerance Name	Edit Code
74-75	Monthly Employment Change	2	10	Low Employment Maximum Employment Difference	091, 126 micro/ macro
76-77	Monthly Employment Change	2	30	High Employment Maximum Employment Difference	091, 126 micro/ macro
78-79	Monthly Employment Change	2	10	Employment Percent Change Limit for ≥ 6 Reported Months	091, 126 micro/ macro
80-81	Monthly Employment Change	2	30	Employment Percent Change Limit for < 6 Reported Months	091, 126 micro/ macro
82-83	Monthly Employment Change	2	10	Employment Check Multiplier	091, 126 micro/ macro
84-85	Wage Change	2	10	No Total Wages with AME Cutoff	092, 093, 127, 130 micro/ macro
86-91	Wage Change	6	10000	Total Wage Change Parm	092, 127 micro/ macro
92-93	Wage Change	2	03	Total Wage Check Multiplier	092, 127 micro/ macro
94-95	Employment Without Wages	2	10	No Wages But AME Multiplier	093, 130 micro/ macro
96-101	Employment Without Wages	6	10000	No Employment with TW Cutoff	092, 094, 127, 131 micro/ macro
102-103	Wages Without Employment	2	3	No Employment with TW Cutoff Multiplier	094, 131 micro/ macro
104-105	Wages/ Employment Sum	2	5	Employment Equals Total Wages Tolerance	095, 132
106-111	Wages/ Employment Sum	6	50	Employment Equals Total Wages AME Cutoff	095, 132
112-113	Wages/ Employment Sum	2	10	Employment Equals Total Wages Multiplier	095, 132
114-119	Zip Code Format	6	99	Zip Code AME Cutoff	104, 108, 111
120-125	Phone Number	6	99	Telephone AME Cutoff	105

Positions	Data Element	Length	State Default Value	Parameter or Tolerance Name	Edit Code
126-131	Physical Address Format	6	0	Physical Location Address AME	114
132-137	Missing Federal EIN	6	50	EIN AME Parm	116
138-139	Missing Federal EIN	2	6	EIN Months Missing	116
140-145	Tax Rate Consistency	6	330	Maximum Tax Rate Deviation	118
146-151	Tax Rate Consistency	6	250	Maximum Contributions Due Deviation	118
152	Tax Rate Consistency	1	0	Bypass Switch for California Rate	118
153-158	Missing Taxable Wages	6	25000	Maximum Total Wages with No Taxable Wages	119
159	Missing Taxable Wages	1	0	Bypass Switch for California Taxable Wages	119
160-161	Non-Economic Code Change	2	5	Noneconomic Code Change Monthly Employment Parm	120
162-163	Logical SIC Change	2	25	Logical SIC Change Employment	122
164-165	Active Account	2	99	Active Account AME	124
166-171	Active Account	6	150000	Active Account Total Wages	124
172-173	Liability	2	99	Liability Check Employment	125
174-179	Liability	6	150000	Liability Check Wages	125
180-185	Identical Monthly Employment	6	50	Maximum Identical Employment AME	128
186-187	Taxable/ Total Wage Change	2	20	Taxable Wages To Total Wages Percent Tolerance	129
188-193	Taxable/ Total Wage Change	6	99	Taxable Wages to Total Wages AME	129
194-195	SIC = 9999	2	25	Unclassified SIC AME	133
196-201	New and Discontinued Edit (Macro)	6	50	Discontinued Record AME	135
202-207	New and Discontinued Edit (Macro)	6	50	New Record AME	135

Positions	Data Element	Length	State Default Value	Parameter or Tolerance Name	Edit Code
208-209	New and Discontinued Edit (Micro)	2	25	Minimum Employment for Predecessor/ Successor, New/ Discontinued Singles	151-163
210-211	New and Discontinued Edit (Micro)	2	25	Employment Cutoff for New/ Discontinued Multis	151-163
212-213	Employment Change for Predecessor/ Successor	2	25 (Edit deferred – zero fill.)	Maximum Allowed Predecessor/ Successor Employment Change	162
214-215	Count Change for Breakout/ Consolidation	2	10 (Edit deferred – zero fill.)	Maximum RU Count Change for Breakout/ Consolidation	162
216-217	Count Change for Breakout/ Consolidation	2	10 (Edit deferred – zero fill.)	Maximum RU Count Percent Change for Breakout/ Consolidation (Non 1st Quarter)	162
218-219	Employment Change for Breakout/ Consolidation	2	50 (Edit deferred – zero fill.)	Employment Difference In Breakout/ Consolidation (Non-1st Quarter)	162
220-221	Employment Change for Breakout/ Consolidation	2	10 (Edit deferred – zero fill.)	Maximum Employment Percent Difference In Breakout/ Consolidation (Non-1st Quarter)	162
222-223	Count Change for Non 999	2	20 (Edit deferred – zero fill.)	Maximum RU Count Change Old County/SIC No 999s (Non-1st Quarter)	162
224-229	Additivity/ Balance (Monthly Employment)	6	50	First Employment Balance Split Level	171-173
230-231	Additivity/ Balance (Monthly Employment)	2	5	Small Employment Balance Tolerance	171-173
232-233	Additivity/ Balance (Monthly Employment)	2	10	Mid-Sized Employment Balance Tolerance	171-173

Positions	Data Element	Length	State Default Value	Parameter or Tolerance Name	Edit Code
234-239	Additivity/ Balance (Monthly Employment)	6	1000	Second Employment Balance Split Level	171-173
240-245	Additivity/ Balance (Monthly Employment)	6	100	Large Employment Balance Tolerance	171-173
246-251	Additivity/ Balance (Monthly Employment)	6	50000	First Wage Balance Split Level	174-176
252-257	Additivity/ Balance (Monthly Employment)	6	250	Small Wage Balance Tolerance	174-176
258-259	Additivity/ Balance (Monthly Employment)	2	10	Medium Wage Mill Balance Tolerance (1/10%)	174-176
260-265	Additivity/ Balance (Monthly Employment)	6	999999	Second Wage Balance Split Level	174-176
266-271	Additivity/ Balance (Monthly Employment)	6	10000	Large Wage Balance Tolerance	174-176
272-277	CCS Division Change	6	100		CCS Table 1A
278-283	CCS Intra-Division Change	6	250		CCS Table 1B
284-289	Wage Record Edit	6	50	Maximum AME for Wage Record Edits Bypass	191-196
290-291	Wage Record Edit	2	10	Limit for Employment > Wage Record Count (Percent)	193-195
292-293	Wage Record Edit	2	20	Limit for Wage Record Count > Employment (Percent)	191
294-299	Wage Record Edit	6	100	Maximum AME for Wage Record Wage Edit Bypass	192, 197
300-301	Wage Record Edit	2	20	Limit for Total Wages > Wage Record Wages (Percent)	192, 197
302-307	AME Print Cutoff	6	0	Average Monthly Employment Print Cutoff Level	

Positions	Data Element	Length	State Default Value	Parameter or Tolerance Name	Edit Code
308-313	AQW Print Cutoff	6	0	Average Quarterly Wage Print Cutoff Level	
314-319	EIN Edit	6	5	Small Record EIN Parm	045
320-325	Wage Change	6	25	Supplemental Edit AME	092, 127
326-331	Wage Change	6	3000	Supplemental Edit AQW Wage Difference	92, 127
332-337	Large New Record Check	6	500	Large New Employer	096, 139
338-343	Large Discontinued Record Check	6	500	Large Discontinued Employer	097, 140
344-349	New Record Check	6	100	New Employer	139
350-355	Discontinued Record Check	6	100	Discontinued Employer	140
356-361	Pred/Succ Employment	6	100 (Edit deferred – zero fill.)	Pred/Succ Employment Difference	162
362-367	Multi-Breakout Employment	6	100 (Edit deferred – zero fill.)	Multi-Establishment Breakout Employment Difference	177
368-373	Multi-Collapse Employment	6	100 (Edit deferred – zero fill.)	Multi-Establishment Collapse Employment Difference	183
374-379	Large Multi-Collapse AME	6	1000 (Edit deferred – zero fill.)	AME for Large Multis	184
380-385	Multi-Collapse AME	6	500 (Edit deferred – zero fill.)	AME for Other Multi-Collapses	184
386-391	Multi-Unit Collapse	6	50 (Edit deferred – zero fill.)	Worksite Unit Count	184
392-397	Comment Error AME	6	10 (Edit deferred – zero fill.)	Small Record Comment Code Parm	048
398-403	Future Use	6	Zero-fill	--	--
404-409	Future Use	6	Zero-fill	--	--
410-415	Future Use	6	Zero-fill	--	--

Positions	Data Element	Length	State Default Value	Parameter or Tolerance Name	Edit Code
416-421	Future Use	6	Zero-fill	--	--
422-427	Future Use	6	Zero-fill	--	--
428-433	Future Use	6	Zero-fill	--	--
434-1190	Filler (blank)	767			

EQUI Trailer Record

The trailer record includes information that the national office uses to compare the expected characteristics of the EQUI file to the actual characteristics. This comparison helps ensure that no records were lost either when the file was created in the state or when it was loaded in the national office.

Positions	Data Element	Length
1	Transaction Code (Always "T")	1
2-3	State FIPS Code	2
4-7	Year	4
8	Quarter	1
9-23	UI Account Number and Reporting Unit Number (Zero-filled)	15
24-31	Count of All Deleted Records	8
<i>Newest Quarter Information (e.g., 2003/1)</i>		
32-36	Newest Year/Quarter	5
37-44	Newest Count of Records	8
<i>Next Oldest Quarter's Information (e.g., 2002/4)</i>		
45-49	Next Oldest Year/Quarter	5
50-57	Next Oldest Count of Records	8
<i>Next Oldest Quarter's Information (e.g., 2002/3)</i>		
58-62	Next Oldest Year/Quarter	5
63-70	Next Oldest Count of Records	8
<i>Next Oldest Quarter's Information (e.g., 2002/2)</i>		
71-75	Next Oldest Year/Quarter	5
76-83	Next Oldest Count of Records	8
<i>Next Oldest Quarter's Information (e.g., 2002/1)</i>		
84-88	Next Oldest Year/Quarter	5
89-96	Next Oldest Count of Records	8
<i>Control Totals for All Quarters for All Ownerships</i>		
97-104	Number of Establishments	8
105-113	First Month Employment	9
114-122	Second Month Employment	9
123-131	Third Month Employment	9
132-145	Total Wages	14
146-159	Taxable Wages	14
160-171	Contributions Due	12
<i>Control Totals for the Current Quarter for All Ownerships</i>		
172-179	Number of Establishments	8
180-188	First Month Employment	9
189-197	Second Month Employment	9
198-206	Third Month Employment	9
207-220	Total Wages	14
221-234	Taxable Wages	14

Positions	Data Element	Length
235-246	Contributions Due	12
<i>Control Totals for the Current Quarter for Federal Government</i>		
247-254	Number of Establishments	8
255-263	First Month Employment	9
264-272	Second Month Employment	9
273-281	Third Month Employment	9
282-295	Total Wages	14
296-309	Taxable Wages	14
310-321	Contributions Due	12
<i>Control Totals for the Current Quarter for State Government</i>		
322-329	Number of Establishments	8
330-338	First Month Employment	9
339-347	Second Month Employment	9
348-356	Third Month Employment	9
357-370	Total Wages	14
371-384	Taxable Wages	14
385-396	Contributions Due	12
<i>Control Totals for the Current Quarter for Local Government</i>		
397-404	Number of Establishments	8
405-413	First Month Employment	9
414-422	Second Month Employment	9
423-431	Third Month Employment	9
432-445	Total Wages	14
446-459	Taxable Wages	14
460-471	Contributions Due	12
<i>Control Totals for the Current Quarter for the Private Sector</i>		
472-479	Number of Establishments	8
480-488	First Month Employment	9
489-497	Second Month Employment	9
498-506	Third Month Employment	9
507-520	Total Wages	14
521-534	Taxable Wages	14
535-546	Contributions Due	12
547-1190	Filler (blank)	654

Appendix L – Code Change Supplement (CCS) File Layout

The CCS file is a compilation of all records with noneconomic code changes in one or more of the essential classification codes. (See Chapter 11 for how records can be put on the CCS.) For most states, these are the county, ownership, and industry codes. Township is also included for New England States (including Connecticut, Maine, Massachusetts, New Hampshire, Rhode Island, and Vermont) and New Jersey.

The following is the layout for the CCS file generated by the national office. The state systems use different variations of this format and some fields may be generated in a different manner. Check system-specific documentation for these formats.

Field Positions	Data Element	Field Length	Comments/Source
1-2	State FIPS Code	2	
3-6	Year	4	Should correspond to the most recent first quarter (e.g. "2020" when 2020/1 is the current quarter)
7-16	UI Account Number	10	
17-21	Reporting Unit Number (RUN)	5	
22-30	Employer Identification Number (EIN)	9	
31-63	Name	33	Trade Name if present; otherwise the Legal Name
64-65	ARS Response Code	2	From the ARS Response Code, if 46 or 50
66	MEEI Code	1	The first quarter MEEI code
67	Filler	1	Blank (formerly Auxiliary Code)
68-71	Filler	4	Blank (formerly Old SIC)
72-77	Filler	6	Blank (formerly Old NSTA)
78-83	Old NAICS Code	6	From the Old NAICS, if present
84	Old Ownership Code	1	From the Old Ownership, if present
85-87	Old County Code	3	From the Old County, if present
88-90	Old Township Code	3	From the Old Township, if present
91-94	Filler	4	Blank (formerly the first quarter SIC)
95-100	Filler	6	Blank (formerly the first quarter NSTA)
101-106	New NAICS Code	6	First quarter NAICS, if different than the Old NAICS
107	New Ownership Code	1	First quarter Ownership, if different than the Old Ownership

Field Positions	Data Element	Field Length	Comments/Source
108-110	New County Code	3	First quarter County, if different than the Old County
111-113	New Township Code	3	First quarter Township, if different than Old Township
114-119	December Employment	6	From Month 3 Employment in fourth quarter
120-125	January Employment	6	From Month 1 Employment in first quarter
126-131	February Employment	6	From Month 2 Employment in first quarter
132-137	March Employment	6	From Month 3 Employment in first quarter
138-148	First Quarter Wages	11	From Total Wages in first quarter
149-159	Fourth Quarter Wages	11	From Total Wages in fourth quarter

Appendix M – Summary of Differences File Layout

The following is the layout for the CCS Summary of Differences file generated by the national office. For each county/ownership/industry cell, the Summary of Differences file shows the economic data that enter or leave due to noneconomic code changes. The standard state systems use the same layout, although some fields may be generated in a different manner.

Field Positions	Data Element	Field Length	Comments/Source
1-2	State FIPS Code	2	
3-5	County Code	3	
6	Ownership Code	1	
7-12	NAICS Code	6	Industry code under which the Summary of Difference is aggregated
13-16	Year	4	Should correspond to the most recent first quarter (e.g. "2020" when 2020/1 is the current quarter)
17-25	December Employment (From)	9	Aggregated from corresponding field of all CCS records leaving the cell
26-39	Fourth Quarter Wages (From)	14	Aggregated from corresponding field of all CCS records leaving the cell
40-48	December Employment (To)	9	Aggregated from corresponding field of all CCS records entering the cell
49-62	Fourth Quarter Wages (To)	14	Aggregated from corresponding field of all CCS records entering the cell
63-71	January Employment (From)	9	Aggregated from corresponding field of all CCS records leaving the cell
72-80	February Employment (From)	9	Aggregated from corresponding field of all CCS records leaving the cell
81-89	March Employment (From)	9	Aggregated from corresponding field of all CCS records leaving the cell
90-103	First Quarter Wages (From)	14	Aggregated from corresponding field of all CCS records leaving the cell
104-112	January Employment (To)	9	Aggregated from corresponding field of all CCS records entering the cell
113-121	February Employment (To)	9	Aggregated from corresponding field of all CCS records entering the cell
122-130	March Employment (To)	9	Aggregated from corresponding field of all CCS records entering the cell
131-144	First Quarter Wages (To)	14	Aggregated from corresponding field of all CCS records entering the cell
145-152	Total Records Leaving	8	Total number of records leaving aggregated cell
153-160	Total Records Entering	8	Total number of records entering aggregated cell

Appendix N – MWR File Layouts

The Electronic Data Interchange Center (EDIC) uses the format below to export Multiple Worksite Report (MWR)/Report of Federal Employment & Wages (RFEW) data files to the states each quarter. This format also provides data fields covering Professional Employer Organizations (PEO) and Payroll Provider Firms (PPF). The Supplemental Record Format is used to export MWR data when additional data elements are required, such as predecessor/successor account information. States should use their standard state processing system (EXPO or WIN) to load these MWR data files as needed to their QCEW during routine quarterly processing. The collection and processing of MWR data by the EDIC is discussed in Chapter 4 – Multiple Worksite Central Reporting.

The EDIC receives the data from reporters (employers or their agents) in various file formats. Reporters are encouraged to use the standard 350 MWR File Format with Four-Digit Year. The national office also collects data from reporters using Multiple Worksite Report Web (MWR Web), an interactive web-based processing system with online editing of various fields including employment and wages.

----- File Layouts -----

Standard 424 MWR File Format Exported to the states from the EDIC
Supplemental P/S Record Format (EDIC)

EDI File Formats:

350 Position MWR File Format– Received by EDIC

Standard 350 MWR File Format (for PEOs) – Received by EDIC

Standard 350 MWR File Format (for PPF's)– Received by EDIC

MWR Web File Formats

Solicitation Request File

State Historical Data File

State Historical Data File – Record Format Type 1 (UI Account)

State Historical Data File - Record Format Type 2 (Worksite)

State Historical Data File – Record Format Type 3 (Worksite-Quarter)

Confirmed Register File Format Exported to the states via MWR Web

479 Position MWR Print Contract Mail File Format – Exported by states to generate mailing by print contractor.

479 Position MWR Print Contract Mail File Format – Exported by states to generate mailing by print contractor. (masters)

479 Position MWR Print Contract Mail File Format – Exported by states to generate mailing by print contractor. (worksites)

424 Position MWR Print Contract Data File Format – Exported by print contractor and sent to the states

Standard 799 MWR File Format Exported to the states via MWR Web (Collected Data file)

Standard 424 MWR File Format Exported to the states from the EDIC

The EDIC uses this format to export reporter data to the states (i.e., “detail records”). Codes in the four fields that occupy positions 309-322 are provided by the EDIC for "birth" records (new establishments) and are generally not provided by reporters.

Position	Length	Data Element	Data Specification
1-2	2	Program Code	Required. A 2-digit program code indicating the type of data being reported. 02 = MWR/QCEW
3	1	Record Type	Required. A 1-digit number indicating the type of reporter: 3 = PEO 4 = PPF 5 = MWR or RFEW
4-5	2	Reference State	Required. The 2-digit state FIPS code indicating the location of the establishment.
6-15	10	UI Account Number	Required. The Unemployment Insurance (UI) account number assigned to the employer by the state. Right-justified, zero-filled.
16-20	5	Reporting Unit Number	Required. The Reporting Unit Number (RUN) assigned by the state to distinguish between records with the same UI account number. Right-justified, zero-filled.
21	1	Format Type	Required. Type = D, for Detail Record. This is not the same as Record Type.
22-30	9	Employer Identification Number (EIN)	Required. The 9-digit EIN assigned to the employer by the Internal Revenue Service (IRS). Numeric, right-justified. Zero-filled if EIN is unknown.
31-65	35	Trade Name	Required if Legal Name is blank. The division or subsidiary name of the establishment. "Mom's Restaurant" is an example of a trade name of ABC Enterprises. Left-justified, blank-filled.
66-100	35	Street Address	The physical street address of the establishment. If provided, is abbreviated as necessary in accordance with the U.S. Postal Service's <u>National Zip Code and Postal Service Directory</u> . Left-justified, blank-filled.
101-130	30	City	The city of the establishment, if provided. Left-justified, blank-filled.
131-132	2	State	If provided, it will be a standard 2-letter Postal Service state abbreviation for the establishment.
133-137	5	Zip Code	If provided, the 5-digit Zip Code used by the Postal Service for the establishment.
138-141	4	Zip Code Extension	The 4-digit Zip Code Extension used by the Postal Service for the establishment. It is zero-filled if no Zip Code Extension is provided.

Position	Length	Data Element	Data Specification
142-143	2	Primary Comment Code	<u>Optional.</u> One of the standard 2-digit comment codes used to explain flagged data, or values that differ substantially from previously reported data. Blank-filled if not used.
144-145	2	Secondary Comment Code	<u>Optional.</u> One of the standard 2-digit comment codes used to explain flagged data, or values that differ substantially from previously reported data. Blank-filled if not used.
146-147	2	Third Comment Code	<u>Optional.</u> One of the standard 2-digit comment codes used to explain flagged data, or values that differ substantially from previously reported data. Blank-filled if not used.
148-151	4	Reference Year	<u>Required.</u> The four digits of the calendar year covered by the report.
152	1	Reference Quarter	<u>Required.</u> The 1-digit number indicating the reference calendar quarter for the report. The calendar quarters are: 1 = January–March 2 = April–June 3 = July–September 4 = October–December
153-187	35	Legal Name	<u>Required if Trade Name is blank.</u> The legal or corporate name of the establishment. For example "ABC Enterprises" or "Smith Companies, Inc." Left-justified, blank-filled.
188-222	35	Reporting Unit Description (RUD)	<u>Required and must be alphanumeric for private (MWR) reporters.</u> For DOD, NFC, and other federal reporters, may be zero-filled. Should contain a meaningful, unique description of the establishment, such as store number or plant name (e.g., Store 101, Jones River Plant). Left-justified, blank-filled.
223-228	6	Month 1 Employment	<u>Required.</u> The number of all full- and part-time employees who worked during or received pay (subject to UI wages) for the pay period which includes the 12th of the month. Right-justified, zero-filled.
229-234	6	Month 2 Employment	<u>Required.</u> The number of all full- and part-time employees who worked during or received pay (subject to UI wages) for the pay period which includes the 12th of the month. Right-justified, zero-filled.
235-240	6	Month 3 Employment	<u>Required.</u> The number of all full- and part-time employees who worked during or received pay (subject to UI wages) for the pay period which includes the 12th of the month. Right-justified, zero-filled.
241-250	10	Quarterly Wages	<u>Required.</u> The total amount of wages (both taxable and non-taxable) paid to employees during the entire reference quarter. All numeric (no \$ signs or commas). Right-justified, zero-filled. Rounded to the nearest dollar (no cents). Zero-filled if no wages were paid.

Position	Length	Data Element	Data Specification
251-307	57	Comments	Optional. Any large changes in employment or wages due to store closings, layoffs, bonuses, seasonal changes, etc. should be explained in this field. If any units of a firm are being reported for the first time following expansion of operations or purchase of units from another firm, a description of the business activity(s) that will be conducted at each establishment should be provided. The national office will use this information in assigning industrial classification codes to the new unit(s). In addition, if units were purchased from another firm, the name of the firm, the effective date of the transaction, and the UI number of the seller, if known, should be provided. If units have been sold to another firm, the name of the firm, the effective date of the transaction, and the UI number of the purchaser, if known, should be provided. Left-justified, blank-filled.
308	1	Source Code (Data Source)	Required. The value is currently "C". This indicates data processed and edited by the EDIC.
309-311	3	County FIPS Code	Required for birth records. 3-digit numeric Federal Information Processing Standard (FIPS) code used to identify each establishment location or place of business.
312-314	3	Township Code	Required for birth records. 3-digit numeric code required in New England states and New Jersey. Used to identify township of each establishment location or place of business.
315	1	Ownership Code	Required for birth records. 1-digit numeric code used to identify the economic ownership of the establishment.
316	1	Filler	Blank
317-322	6	NAICS Code	Required for birth records. 6-digit numeric code used to identify the primary activity of the establishment.
323-326	4	Agent Code	Applicable to record type 4 (PPF).
327-330	4	Initial Date of Liability - Year	The four-digit year of a firm's initial liability date. This is applicable to birth records for record types 3, 4, and 5.
331-332	2	Initial Date of Liability – Month	The two-digit month of a firm's initial liability date. This is applicable to birth records for record types 3, 4, and 5.
333-334	2	Initial Date of Liability – Day	The two-digit day of a firm's initial liability date. This is applicable to birth records for record types 3, 4, and 5.
335-338	4	End of Liability Date – Year	The four-digit year of a firm's end of liability date. This is applicable to death records for record types 3, 4, and 5.
339-340	2	End of Liability Date – Day	The two-digit month of a firm's end of liability date. This is applicable to death records for record types 3, 4, and 5.

Position	Length	Data Element	Data Specification
341-342	2	End of Liability Date – Year	The two-digit day of a firm's end of liability date. This is applicable to death records for record types 3, 4, and 5.
343-346	4	Reactivation Date - Year	The four-digit year of a firm's re-activation date. This is applicable to record types 3, 4, and 5.
347-348	2	Reactivation Date – Month	The two-digit month of a firm's re-activation date. This is applicable to record types 3, 4, and 5.
349-350	2	Reactivation Date – Day	The two-digit day of a firm's re-activation date. This is applicable to record types 3, 4, and 5.
351-360	10	Client UI Account Number	The UI account number assigned to the client before the client entered the co-employer relationship with the Professional Employer Organization (PEO). Right-justified, zero-filled.
361-369	9	Client EIN	The EIN assigned to the client before the client entered the co-employer relationship with the Professional Employer Organization (PEO).
370-379	10	Client Telephone Number	The telephone number of the client.
380-381	2	Month Became Client	The 2-digit month that the record became a client of the PEO.
382-385	4	Year Became Client	The 4-digit year that the record became a client of the PEO.
386-387	2	Month Client Terminated	The 2-digit month that the record terminated being a client of the PEO.
388-391	4	Year Client Terminated	The 4-digit year that the record terminated being a client of the PEO.
392-424	33	Worksite Economic Activity Description	A description of the client worksite's economic activity. Economic activity is the principal business(es) in which the worksite is engaged.

Supplemental P/S Record Format (EDIC)

Supplemental predecessor/successor (P/S) records provided by the EDIC to states contain detailed information about the relationship between a predecessor and its successor. This means that for each identified predecessor/successor relationship (or pair), two records are generated: one for the predecessor and one for the successor. These records are included within the Standard 424 MWR File as supplemental records below each “detail” 424 position record as applicable. Please note that not all “detail” records exported by the EDIC will have associated predecessor and successor records.

Position	Length	Data Element	Data Specification
1-2	2	Program Code	A 2-digit program code indicating the type of data being reported. 02 = MWR/QCEW
3	1	Record Type	A 1-digit number indicating the type of reporter. Type = 3, PEO; Type = 4, PPF; Type = 5, MWR/RFEW
4-5	2	Reference State	The 2-digit state FIPS code indicating the location of the establishment.
6-15	10	UI Account Number	The UI account number assigned to the employer by the state. Right-justified, zero-filled.
16-20	5	Reporting Unit Number	The RUN assigned to the establishment by the state to distinguish between records with the same UI Account Number. Right-justified, zero-filled.
21	1	Action Code	Blank = predecessor or successor data provided; D = delete record
22	1	Format Type	P = The UI/RUN identified in positions 6-20 has a Predecessor S = The UI/RUN identified in positions 6-20 has a Successor
23-32	10	Pred/Succ UI Account Number	The UI account number of the Predecessor (Successor) to the UI/RUN identified in positions 6-20.
33-37	5	Pred/Succ Reporting Unit Number	The RUN of the Predecessor (Successor) to the UI/RUN identified in positions 6-20.
38-41	4	Reference Year	The 4-digit year of the current processing year.
42	1	Reference Quarter	The 1-digit quarter of the current processing quarter.

EDI File Formats:**350 Position MWR File Format– Received by EDIC**

Position	Length	Data Element	Data Specification
1-2	2	Program Code	<u>Required.</u> A 2-digit program code indicating the type of data being reported. 02 = MWR
3	1	Record Type	<u>Required.</u> A 1-digit number indicating the record format is Y2K compliant. Value = 2 for this record format. 1 = The file format is not Y2K compliant 2 = The file format is Y2K compliant - All values of 2 and greater are Y2K compliant. 3 = The reporter is a Professional Employer Organization (PEO) 4 = The reporter is a Payroll Provider Firm (PPF)
4-5	2	Reference State	<u>Required.</u> The 2-digit state FIPS code indicating the location of the establishment.
6-15	10	UI Account Number	<u>Required.</u> The UI account number assigned to the employer by the state. Right-justified, zero-filled.
16-20	5	Reporting Unit Number	<u>Required.</u> The RUN number assigned by the state to distinguish between records with the same UI Account Number. Right-justified, zero-filled.
21-29	9	Employer Identification Number	<u>Required.</u> The 9-digit EIN assigned to the employer by the IRS. Numeric, right-justified. Should be zero-filled if EIN is unknown.
30-64	35	Trade Name	<u>Required.</u> The division or subsidiary name of the establishment. "Mom's Restaurant" is an example of a trade name of ABC Enterprises. Left-justified, blank-filled.
65-99	35	Street Address	<u>Required.</u> The physical street address of the establishment. Abbreviate as necessary in accordance with the U.S. Postal Service's National Zip Code and Postal Service Directory. Left-justified, blank-filled.
100-129	30	City	<u>Required.</u> The city of the establishment. Left-justified, blank-filled.
130-131	2	State	<u>Required.</u> The standard 2-letter Postal Service state abbreviation for the establishment.
132-136	5	Zip Code	<u>Required.</u> The 5-digit Zip Code used by the Postal Service for the establishment.
137-140	4	Zip Code Extension	<u>Optional.</u> The 4-digit Zip Code Extension used by the Postal Service for the establishment. Zero-filled if not used.
141-142	2	Delivery Point Bar-code	<u>Optional.</u> The 2-digit delivery point Bar-code used by the Postal Service for the establishment. Zero-filled if not used.

Position	Length	Data Element	Data Specification
143-144	2	Primary Comment Code	<u>Optional.</u> One of the standard 2-digit comment codes used to explain data values that differ substantially from previously reported data. Blank-filled if not used.
145-146	2	Secondary Comment Code	<u>Optional.</u> One of the standard 2-digit comment codes used to explain data values that differ substantially from previously reported data. Blank-filled if not used.
147-148	2	Third Comment Code	<u>Optional.</u> One of the standard 2-digit comment codes used to explain data values that differ substantially from previously reported data. Blank-filled if not used.
149-152	4	Reference Year	<u>Required.</u> The four digits of the calendar year covered by the report.
153	1	Reference Quarter	<u>Required.</u> The 1-digit number indicating the reference calendar quarter for the report. The calendar quarters are: 1 = January - March 2 = April - June 3 = July - September 4 = October - December
154-188	35	Legal Name	<u>Optional.</u> The legal or corporate name of the establishment. For example "ABC Enterprises" or "Smith Companies, Inc." Left-justified, blank-filled.
189-223	35	Worksite Description	<u>Required.</u> A meaningful, unique description of the establishment, such as store number or plant name (e.g., Store 101, Jones River Plant). Left-justified, blank-filled.
224-229	6	Month 1 Employment	<u>Required.</u> The number of all full- and part-time employees who worked during or received pay (subject to UI wages) for the pay period which includes the 12th of the month. Right-justified, zero-filled.
230-235	6	Month 2 Employment	<u>Required.</u> The number of all full- and part-time employees who worked during or received pay (subject to UI wages) for the pay period which includes the 12th of the month. Right-justified, zero-filled.
236-241	6	Month 3 Employment	<u>Required.</u> The number of all full- and part-time employees who worked during or received pay (subject to UI wages) for the pay period which includes the 12th of the month. Right-justified, zero-filled.
242-251	10	Quarterly Wages	<u>Required.</u> The total amount of wages (both taxable and non-taxable) paid to employees during the entire reference quarter. Must be numeric (no \$ signs or commas). Right-justified and zero-filled.. Should be rounded to the nearest dollar (no cents). Zero-filled if no wages were paid.

Position	Length	Data Element	Data Specification
252-301	50	Comments	<u>Optional.</u> Any large changes in employment or wages due to store closure, layoffs, bonuses, seasonal changes, etc. should be explained in this field. If any units of a firm are being reported for the first time following expansion of operations or purchase of units from another firm, a description of the business activity(s) that will be conducted at each establishment should be provided. The national office will use this information in assigning industrial classification codes to the new unit(s). In addition, if units were purchased from another firm, the name of the firm, the effective date of the transaction, and the UI number of the seller, if known, should be provided. If units have been sold to another firm, the name of the firm, the effective date of the transaction, and the UI number of the purchaser, if known, should be provided. Left-justified, blank-filled.
302-322	21	Worksite Identification Code	<u>Required.</u> Alpha/numeric indicator that uniquely identifies the business at this physical location. This code should not be duplicated within a state UI number. This field is reserved to include crosswalk information provided by an employer so that the EDIC may process the data to assign UI/RUNs. There is no unique format within these 21 positions as they are dependent upon the reporter. Left-justified, blank-filled.
323-350	28	Blank	For future use. Blank-filled.

Standard 350 MWR File Format (for PEOs) – Received by EDIC

Position	Length	Data Element	Data Specification
1-2	2	Program Code	<u>Required.</u> A 2-digit program code indicating the type of data being reported. 02 = MWR
3	1	Record Type	<u>Required.</u> A 1-digit number indicating the reporter is a PEO. Value = 3 for this format. 1 = The file format is not Y2K compliant 2 = The file format is Y2K compliant – All values of 2 and greater are Y2K compliant. 3 = The reporter is a PEO 4 = The reporter is a PPF
4-5	2	Reference State	<u>Required.</u> The 2-digit state FIPS code indicating the location of the client establishment (State where PEO pays UI taxes for that client).

Position	Length	Data Element	Data Specification
6-15	10	UI Account Number	<u>Required.</u> The UI account number assigned to the PEO and pertaining to the state listed above. Right-justified, zero-filled.
16-20	5	Reporting Unit Number	<u>Required.</u> The RUN assigned by the state to distinguish between records with the same UI Account Number. Right-justified, zero-filled.
21-29	9	Employer Identification Number	<u>Required.</u> The 9-digit EIN assigned to the PEO by the IRS. Numeric, right-justified. Zero-filled if EIN is unknown.
30-64	35	Trade Name	<u>Required.</u> The name of the client establishment. “Mom’s Restaurant” is an example of a trade name of ABC Enterprises. Left-justified, blank-filled.
65-99	35	Street Address	<u>Required.</u> The physical street address of the client establishment. Abbreviate as necessary in accordance with the U.S. Postal Service’s National Zip Code and Postal Service Directory. Left-justified, blank filled.
100-129	30	City	<u>Required.</u> The city of the client establishment. Left-justified, blank filled.
130-131	2	State	<u>Required.</u> The standard 2-letter Postal Service state abbreviation for the client establishment.
132-136	5	Zip Code	<u>Required.</u> The 5-digit Zip Code used by the Postal Service for the client establishment.
137-140	4	Zip Code Extension	<u>Optional.</u> The 4-digit Zip Code Extension used by the Postal Service for the client establishment. Zero-filled if not used.
141-142	2	Delivery Point Bar-code	<u>Optional.</u> The 2-digit delivery point Bar-code used by the Postal Service for the establishment. Zero-filled if not used.
143-144	2	Primary Comment Code	<u>Optional.</u> One of the standard 2-digit comment codes used to explain data values that differ substantially from previously reported data. Blank-filled if not used.
145-146	2	Secondary Comment Code	<u>Optional.</u> One of the standard 2-digit comment codes used to explain data values that differ substantially from previously reported data. Blank-filled if not used.
147-148	2	Third Comment Code	<u>Optional.</u> One of the standard 2-digit comment codes used to explain data values that differ substantially from previously reported data. Blank-filled if not used.
149-152	4	Reference Year	<u>Required.</u> The four digits of the calendar year covered by the report.
153	1	Reference Quarter	<u>Required.</u> The 1-digit number indicating the reference calendar quarter for the report. The calendar quarters are: 1 = January – March 2 = April – June 3 = July – September 4 = October – December
154-188	35	Legal Name	<u>Required.</u> The legal or corporate name of the client establishment. For example “ABC Enterprises” or “Smith Companies, Inc.” Left-justified, blank-filled.

Position	Length	Data Element	Data Specification
189-223	35	Worksite Description	<u>Required.</u> Enter a meaningful, unique description of the client establishment, such as store number or plant name (e.g., Store 101, Jones River Plant). Left-justified, blank-filled.
224-229	6	Month 1 Employment	<u>Required.</u> The number of all full- and part-time employees who worked during or received pay (subject to UI wages) for the pay period which includes the 12 th of the month. Right-justified, zero filled.
230-235	6	Month 2 Employment	<u>Required.</u> The number of all full- and part-time employees who worked during or received pay (subject to UI wages) for the pay period which includes the 12 th of the month. Right-justified, zero filled.
236-241	6	Month 3 Employment	<u>Required.</u> The number of all full- and part-time employees who worked during or received pay (subject to UI wages) for the pay period which includes the 12 th of the month. Right-justified, zero filled.
242-251	10	Quarterly Wages	<u>Required.</u> The total amount of wages (both taxable and non-taxable) paid to employees during the entire reference quarter. Must be numeric (no \$ signs or commas). Right-justified and zero-filled. Should be rounded to the nearest dollar (no cents). Zero-filled if no wages were paid.
252-261	10	Client UI Account Number	The UI account number assigned to the client before entering the co-employer relationship with the PEO. Right-justified, zero-filled.
262-267	6	Client SIC or NAICS Code	The 4-digit SIC or 6-digit NAICS code assigned to the client. Right-justified, zero-filled.
268-301	34	Client Economic Activity	The Client Economic Activity describes the principal business(es) in which the client is engaged. Left-justified.
302-322	21	Worksite Identification Code	<u>Required.</u> Alpha/numeric indicator that uniquely identifies the business at this physical location. This code should not be duplicated within a state UI number. This field is reserved to include crosswalk information provided by an employer so that the EDIC may process the data to assign UI/RUNs. There is no unique format within these 21 positions as they are dependent upon the reporter. Left-justified, blank-filled.
323-331	9	Client EIN	<u>Required.</u> The federal Employer Identification Number (EIN) assigned to the client before entering the co-employer relationship with the Professional Employer Organization (PEO).
332-341	10	Client Telephone Number	<u>Required.</u> The telephone number of the client.
342-343	2	Month Became Client	<u>Required.</u> The 2-digit month that the record became a client of the PEO.

Position	Length	Data Element	Data Specification
344-345	2	Year Became Client	<u>Required.</u> The 2-digit year that the record became a client of the PEO.
346-347	2	Month Client Terminated	<u>Required.</u> The 2-digit month that the record terminated being a client of the PEO.
348-349	2	Year Client Terminated	<u>Required.</u> The 2-digit year that the record terminated being a client of the PEO.
350	1	Blank	For future use. Blank-filled.

Standard 350 MWR File Format (for PPF's)– Received by EDIC

Position	Length	Data Element	Data Specification
1-2	2	Program Code	<u>Required.</u> A 2-digit program code indicating the type of data being reported. 02 = MWR
3	1	Record Type	<u>Required.</u> A 1-digit number indicating the record format is Y2K compliant. Value = 4 for this format. 1 = The file format is not Y2K compliant 2 = The file format is Y2K compliant - All values of 2 and greater are Y2K compliant. 3 = The reporter is a PEO 4 = The reporter is a PPF
4-5	2	Reference State	<u>Required.</u> The 2-digit state FIPS code indicating the location of the establishment.
6-15	10	UI Account Number	<u>Required.</u> The Unemployment Insurance (UI) account number assigned to the employer by the state. Right-justified, zero-filled.
16-20	5	Reporting Unit Number	<u>Required.</u> The number assigned by the state to distinguish between records with the same UI Account Number. Right-justified, zero-filled.
21-29	9	Employer Identification Number (EIN)	<u>Required.</u> The 9-digit EIN assigned to the employer by the IRS. Numeric, right-justified. Zero-filled if EIN is unknown.
30-64	35	Trade Name	<u>Required.</u> The division or subsidiary name of the establishment. "Mom's Restaurant" is an example of a trade name of ABC Enterprises. Left-justified, blank-filled.
65-99	35	Street Address	<u>Required.</u> The physical street address of the establishment. Abbreviate as necessary in accordance with the U.S. Postal Service's National Zip Code and Postal Service Directory. Left-justified, blank-filled.
100-129	30	City	<u>Required.</u> The city of the establishment. Left-justified, blank-filled.

Position	Length	Data Element	Data Specification
130-131	2	State	<u>Required.</u> The standard 2-letter Postal Service state abbreviation for the establishment.
132-136	5	Zip Code	<u>Required.</u> The 5-digit Zip Code used by the Postal Service for the establishment.
137-140	4	Zip Code Extension	<u>Optional.</u> The 4-digit Zip Code Extension used by the Postal Service for the establishment. Zero-filled if not used.
141-142	2	Delivery Point Bar-code	<u>Optional.</u> The 2-digit delivery point Bar-code used by the Postal Service for the establishment. Zero-filled if not used.
143-144	2	Primary Comment Code	<u>Optional.</u> One of the standard 2-digit comment codes used to explain data values that differ substantially from previously reported data. Blank-filled if not used.
145-146	2	Secondary Comment Code	<u>Optional.</u> One of the standard 2-digit comment codes used to explain data values that differ substantially from previously reported data. Blank-filled if not used.
147-148	2	Third Comment Code	<u>Optional.</u> One of the standard 2-digit comment codes used to explain data values that differ substantially from previously reported data. Blank-filled if not used.
149-152	4	Reference Year	<u>Required.</u> The four digits of the calendar year covered by the report.
153	1	Reference Quarter	<u>Required.</u> The 1-digit number indicating the reference calendar quarter for the report. The calendar quarters are: 1 = January - March 2 = April - June 3 = July - September 4 = October - December
154-188	35	Legal Name	<u>Required.</u> The legal or corporate name of the establishment. For example "ABC Enterprises" or "Smith Companies, Inc." Left-justified, blank-filled.
189-223	35	Worksite Description	<u>Required.</u> A meaningful, unique description of the establishment, such as store number or plant name (e.g., Store 101, Jones River Plant). Left-justified, blank-filled.
224-229	6	Month 1 Employment	<u>Required.</u> The number of all full- and part-time employees who worked during or received pay (subject to UI wages) for the pay period which includes the 12th of the month. Right-justified, zero-filled.
230-235	6	Month 2 Employment	<u>Required.</u> The number of all full- and part-time employees who worked during or received pay (subject to UI wages) for the pay period which includes the 12th of the month. Right-justified, zero-filled.
236-241	6	Month 3 Employment	<u>Required.</u> The number of all full- and part-time employees who worked during or received pay (subject to UI wages) for the pay period which includes the 12th of the month. Right-justified, zero-filled.

Position	Length	Data Element	Data Specification
242-251	10	Quarterly Wages	<u>Required.</u> The total amount of wages (both taxable and non-taxable) paid to employees during the entire reference quarter. Must be numeric (no \$ signs or commas). Right-justified and zero-filled. Should be rounded to the nearest dollar (no cents). Zero-filled if no wages were paid.
252-261	10	Client Contact Phone Number	<u>Required.</u> The phone number (with area code) of the client's contact person to call in reference to data questions. Parentheses and hyphens should be omitted.
262-301	40	Client Contact Name	<u>Required.</u> The name of the client's contact person. Left-justified, blank-filled.
302-322	21	Worksite Identification Code	<u>Required.</u> Alpha/numeric indicator that uniquely identifies the business at this physical location. This code should not be duplicated within a state UI number. This field is reserved to include crosswalk information provided by an employer so that the EDIC may process the data to assign UI/RUNs. There is no unique format within these 21 positions as they are dependent upon the reporter. Left-justified, blank-filled.
323-350	28	Filler2	For future use. Blank-filled.

MWR Web File Formats

Solicitation Request File

The MWR Web solicitation request file is sent by the national office to the states on a quarterly basis. The request file contains the identification of employers that the national office has selected to be solicited to participate in providing MWR data via MWR Web.

Position	Length	Data Element	Data Specification
1-2	2	Program Code	<u>Required.</u> A 2-digit program code indicating the type of data being reported. 02 = MWR data for the QCEW program
3	1	Record Type	<u>Required.</u> A 1-digit number indicating the record format. "1" = MWR Web Solicitation Request File
4-5	2	Reference State	<u>Required.</u> The 2-digit state FIPS code indicating the location of the establishment.
6-15	10	UI Account Number	<u>Required.</u> The UI account number assigned to the employer by the state. Right-justified, zero-filled.
16-24	9	Employer Identification Number	The 9-digit EIN assigned to the employer by the IRS. When used in the MWR Web system this field will always be blank.
25-36	12	IDCF Temporary Account Number	Temporary Account Number that the Respondent will need in order to register for MWR Web. The

Position	Length	Data Element	Data Specification
			IDCF Temporary Account and Password should appear on initial and follow-up solicitation forms, but should be retained for only the one quarter. Once the employer registers and reports this information it is not used in the EXPO and WIN systems again.
37-44	8	IDCF Temporary Password	Temporary Password that the Respondent will need in order to register for MWR Web
45-48	4	Reference Year	<u>Required.</u> The four digits of the calendar year covered by the report.
49	1	Reference Quarter	<u>Required.</u> The 1-digit number indicating the reference calendar quarter for the report. The calendar quarters are: 1 = January–March 2 = April–June 3 = July–September 4 = October–December

State Historical Data File

States send the State Historical Data file to the national office on a quarterly basis. Every record on the *State Historical Data File* is identified by a *Format Type* value, which indicates its format. The three possible *Format Types* in the *State Historical Data File* correspond to the three major entities that are covered by the MWR survey:

Format Type	Data Specification
1	Information about a UI account
2	Information about a worksite
3	Information about one quarter of data for a worksite

Note: For a given UI account, all records on the state EXPO and WIN-202 database should be included on the State Historical Data file, regardless of the Status Code: active, inactive, and pending records. Further note, some inactive records may have no quarterly records for the time period requested. Pending records may not have quarterly data either.

State Historical Data File – Record Format Type 1 (UI Account)

Position	Length	Data Element	Data Specification
1-2	2	Reference State	<u>Required.</u> The 2-digit state FIPS code indicating the location of the establishment.
3-12	10	UI Account Number	<u>Required.</u> The UI account number assigned to the employer by the state. Right-justified, zero-filled.
13-21	9	Blank	Not Used.

Position	Length	Data Element	Data Specification
22	1	MWR Mailing Indicator	Mailing Code (EXPO)/MWR Mailing Indicator (WIN) of UI Account's master RUN (00000)
23	1	Format Type	1 = UI Account
24-32	9	Employer Identification Number	The 9-digit EIN assigned to the employer by the IRS.
33-42	10	Predecessor UI Account Number	The UI account number of the predecessor, if applicable. If none, then blank.
43	1	Ownership Code	1-digit numeric code used to identify the economic ownership of the enterprise.
44-78	35	Legal Name	The Legal Name of the UI account. (Trade Name not used here. It is used only in Format Type 2—Worksite). Left-justified, blank-filled.
79-113	35	Contact Name	Contact Name or Attention Line. Left-justified, blank-filled.
114-148	35	Mailing Other Address 1	The address that would be used to mail the MWR to the respondent for the UI account. Left-justified, blank-filled.
149-183	35	Mailing Other Address 2	See note above. May also be left blank.
184-213	30	Mailing Other Address City	The city that would be used to mail the MWR to the respondent for the UI account. Left-justified, blank-filled.
214-215	2	Mailing Other State	The standard 2-letter Postal Service state abbreviation that would be used to mail the MWR to the respondent for the UI account.
216-220	5	Mailing Other Zip Code	The Zip Code that would be used to mail the MWR to the respondent for the UI account.
221-224	4	Mailing Other Zip Code Extension	The Zip Code Extension that would be used to mail the MWR to the respondent for the UI account. If unavailable, blank.
225-284	60	Email address	Contact's e-mail address. Left-justified, blank-filled.
285-294	10	Fax Number	Contact's fax number if provided, otherwise blank. (No parentheses or hyphens)
295-304	10	Phone Number	Contact's phone number. (No parentheses or hyphens)
305-309	5	Phone Number Extension	Contact's phone extension if provided, otherwise blank.
310-313	4	Agent Code	State-defined 4-digit agent code (used for payroll service or similar agency). Blank if not used.

Position	Length	Data Element	Data Specification
314-318	5	Maximum RUN	The highest used value of RUN for any worksite in this UI account. Right-justified, zero-filled.

State Historical Data File - Record Format Type 2 (Worksite)

Position	Length	Data Element	Data Specification
1-2	2	Reference State	<u>Required.</u> The 2-digit state FIPS code indicating the location of the establishment.
3-12	10	UI Account Number	<u>Required.</u> The UI account number assigned to the employer by the state. Right-justified, zero-filled.
13-17	5	Reporting Unit Number	RUN of the worksite within the UI account. Right-justified, zero-filled.
18-22	5	Blank	All blank.
23	1	Format Type	2 = Worksite
24-33	10	Predecessor UI Account Number	The UI account number of the predecessor, if applicable. If none, then blank.
34-38	5	Predecessor Reporting Unit Number	The RUN of the predecessor, if applicable. Right-justified, blank-filled. If none, then blank.
39-73	35	Trade Name	The division or subsidiary name of the establishment. Left-justified, blank-filled.
74-108	35	Physical Location Address	Physical address of the establishment. Line 1 of the PLA street address; if Line 1 is not available, line 2 used. Left-justified, blank-filled.
109-138	30	City	City of the establishment. Left-justified, blank-filled.
139-140	2	State	The standard 2-letter Postal Service state abbreviation.
141-145	5	Zip Code	Zip Code used by the Postal Service for the establishment.
146-149	4	Zip Code Extension	Zip Code Extension used by the Postal Service for the establishment. If unavailable, blank.
150-184	35	Worksite Description	A meaningful, unique description of the establishment, such as store number or plant name. Left-justified, blank-filled.
185-187	3	County Code	3-digit numeric Federal Information Processing Standard (FIPS) county code used to identify each reporting unit's location or place of business.
188-190	3	Township Code	3-digit numeric township code required in New England states and New Jersey, used to

Position	Length	Data Element	Data Specification
			identify township of location or place of business. If not applicable, blank.
191	1	Auxiliary Code	Blank
192-197	6	NAICS	North American Industry Classification System code
198-318	121	Blank	Not used – blank.

State Historical Data File – Record Format Type 3 (Worksite-Quarter)

Position	Length	Data Element	Data Specification
1-2	2	Reference State	<u>Required.</u> The 2-digit state FIPS code indicating the location of the establishment.
3-12	10	UI Account Number	<u>Required.</u> The UI account number assigned to the employer by the state. Right-justified, zero-filled.
13-17	5	Reporting Unit Number	RUN of the worksite within the UI account. Right-justified, zero-filled.
18-21	4	Year	Year of data collection for this worksite
22	1	Quarter	Quarter of data collection for this worksite
23	1	Format Type	Format Type. 3 = Worksite-Quarter
24	1	Status Code	1 = active 2 = inactive 9 = pending
25-30	6	Month 1 Employment	Month 1 employment. Right-justified, zero-filled.
31	1	Month 1 Employment Indicator	First month employment indicator flag
32-37	6	Month 2 Employment	Month 2 employment. Right-justified, zero-filled.
38	1	Month 2 Employment Indicator	Second month employment indicator flag
39-44	6	Month 3 Employment	Month 3 employment. Right-justified, zero-filled.
45	1	Month 3 Employment Indicator	Third month employment indicator flag
46	11	Total Wages	Total Wages. Right-justified, zero-filled.
57	1	Total Wage Indicator	Total Wages Indicator Flag

Position	Length	Data Element	Data Specification
58-59	2	Comment Code 1	Comment code #1: Standard 2-digit comment codes used to explain data values that differ substantially from previously reported data
60-61	2	Comment Code 2	Comment code #2. See above.
62-63	2	Comment Code 3	Comment code #3. See above.
64-120	57	Narrative Comment	Explanation of large changes in employment or wages due to store closure, layoffs, bonuses, seasonal changes. Left-justified, blank-filled.
121-318	198	Blank	Not used – blank.

Confirmed Register File Format Exported to the states via MWR Web

A list of firms that have been solicited, registered to participate in MWR Web, and completed entering data for their UI account area are provided in the Confirmed Register File provided to the states by the national office/Division of Business Establishment Systems (DBES) in the 29 position file layout given below.

Position	Length	Data Element	Data Specifications
1-2	2	Program Code	02 = QCEW
3	1	Filler	Blank
4-5	2	Reference State	The 2-digit numeric FIPS code of the state.
6-15	10	UI Account Number	The UI account number assigned to the employer by the state. Right-justified, zero-filled.
16-24	9	Filler	Blank
25-28	4	Year	Year of data collection for this account.
29	1	Quarter	Quarter of data collection for this account.

479 Position MWR Print Contract Mail File Format – Exported by states to generate mailing by print contractor.

Format Type	Data Specification
RUN = 00000	Information about a UI account
RUN > 00000	Information about a worksite

Note: The sorting of this file is such that all records with the same UI Account Number are grouped together and sorted ascending, but the records are then sorted on RUN with the >00000 RUNs appearing first, sorted ascending, and the RUN 00000 record last.

Example:

FIPS/UIN/RUN
01/0123456789/00001

01/0123456789/00002
 01/0123456789/00003
 01/0123456789/00000
 01/0123456790/00001
 01/0123456790/00003
 01/0123456790/00000

479 Position MWR Print Contract Mail File Format – Exported by states to generate mailing by print contractor. (masters)

Position	Length	Data Element	Data Specification
1-2	2	State FIPS Code	<u>Required.</u> Right-justified, leading 0's
3-12	10	UI Account Number	<u>Required.</u> The UI account number assigned to the employer by the state. Right-justified, zero-filled.
13-17	5	Reporting Unit Number	<u>Required.</u> The RUN assigned by the state to distinguish between records with the same UI Account Number. Right-justified, zero-filled.
18-26	9	Federal Employer Identification Number	The 9-digit EIN assigned to the employer by the IRS. Numeric, right-justified. Should be zero-filled if EIN is unknown.
27-61	35	Trade Name	Left-justify, trailing spaces.
62-96	35	Legal Name	Left-justify, trailing spaces.
97-131	35	UI Contact (Attention) Name	Left-justify, trailing spaces.
132-166	35	MOA - Delivery Address Line	Left-justify, trailing spaces.
167-201	35	MOA - Secondary Address Line	Left-justify, trailing spaces.
202-231	30	MOA - City	Left-justify, trailing spaces.
232-233	2	MOA - State	If foreign, blank; if Canadian, Canadian province abbr.
234-238	5	MOA - Zip Code	If foreign, leave blank.
239-242	4	MOA - Zip 4 Extension	If foreign, leave blank.
243-277	35	PLA - Street Address	Space-fill, for RUN > 00000 records only.
278-312	35	PLA - Supplemental Location Information	Space-fill, for RUN > 00000 records only.
313-342	30	PLA - City	Space-fill, for RUN > 00000 records only.
343-344	2	PLA - State	Space-fill, for RUN > 00000 records only.
345-349	5	PLA - Zip Code	Space-fill, for RUN > 00000 records only.
350-353	4	PLA - ZIP 4 Extension	Space-fill, for RUN > 00000 records only.
354-388	35	Reporting Unit Description	Space-fill, for RUN > 00000 records only.
389-392	4	Year	<u>Required.</u> Year of collection, specified when generating file.

Position	Length	Data Element	Data Specification
393	1	Quarter	<u>Required.</u> Quarter of collection, specified when generating file.
394	1	Request Type	If first mailing, "1"; if subsequent mailing, "2".
395	1	Ownership Code	1-digit numeric code used to identify the economic ownership of the establishment.
396	1	MEEI Code	1-digit numeric code used to identify the relationship of the record to those of its broader UI Account
397-402	6	NAICS Code	Space-fill, for RUN > 00000 records only.
403-408	6	Month One Employment	Space-fill, for RUN > 00000 records only.
409-414	6	Month Two Employment	Space-fill, for RUN > 00000 records only.
415-420	6	Month Three Employment	Space-fill, for RUN > 00000 records only.
421-430	10	Total Wages	Space-fill, for RUN > 00000 records only.
431-432	2	Filler	Space-fill.
433-435	3	County Code	Space-fill, for RUN > 00000 records only.
436-439	4	Township/Zone Code	Space-fill, for RUN > 00000 records only.
440-449	10	Phone Number	Respondent phone number
450-461	12	MWR Web ID	12-digit numeric ID provided by MWR Web Solicitation Request File, used by respondents for first-time online login
462-469	8	MWR Web Password	8-digit alpha-numeric password, case sensitive, provided by MWR Web Solicitation Request File, used by respondents for first-time online login
470-472	3	MOA - Foreign Country	Left-justified, trailing spaces.
473-479	7	MOA - Foreign Postal Code	Left-justified, trailing spaces.

479 Position MWR Print Contract Mail File Format – Exported by states to generate mailing by print contractor. (worksites)

Position	Length	Data Element	Data Specification
1-2	2	State FIPS Code	<u>Required.</u> Right-justified, leading 0's
3-12	10	UI Account Number	<u>Required.</u> The UI account number assigned to the employer by the state. Right-justified, zero-filled.
13-17	5	Reporting Unit Number	<u>Required.</u> The RUN assigned by the state to distinguish between records with the same UI Account Number. Right-justified, zero-filled.

Position	Length	Data Element	Data Specification
18-26	9	Federal Employer Identification Number	The 9-digit EIN assigned to the employer by the IRS. Numeric, right-justified. Should be zero-filled if EIN is unknown.
27-61	35	Trade Name	Left-justify, trailing spaces.
62-96	35	Legal Name	Left-justify, trailing spaces.
97-131	35	UI Contact (Attention) Name	Left-justify, trailing spaces.
132-166	35	MOA - Delivery Address Line	Space-fill, for RUN = 00000 records only.
167-201	35	MOA - Secondary Address Line	Space-fill, for RUN = 00000 records only.
202-231	30	MOA - City	Space-fill, for RUN = 00000 records only.
232-233	2	MOA - State	Space-fill, for RUN = 00000 records only.
234-238	5	MOA - Zip Code	Space-fill, for RUN = 00000 records only.
239-242	4	MOA - Zip 4 Extension	Space-fill, for RUN = 00000 records only.
243-277	35	PLA - Street Address	Left-justify, trailing spaces.
278-312	35	PLA - Supplemental Location Information	Left-justify, trailing spaces.
313-342	30	PLA - City	Left-justify, trailing spaces.
343-344	2	PLA - State	If foreign, blank; if Canadian, Canadian province abbr.
345-349	5	PLA - Zip Code	If foreign, leave blank.
350-353	4	PLA - ZIP 4 Extension	If foreign, leave blank.
354-388	35	Reporting Unit Description	Left-justify, trailing spaces.
389-392	4	Year	Space-fill, for RUN = 00000 records only.
393	1	Quarter	Space-fill, for RUN = 00000 records only.
394	1	Request Type	If first mailing, "1"; if subsequent mailing, "2".
395	1	Ownership Code	1-digit numeric code used to identify the economic ownership of the establishment.
396	1	MEEI Code	1-digit numeric code used to identify the relationship of the record to those of its broader UI Account
397-402	6	NAICS Code	6-digit numeric code used to identify the primary activity of the establishment.
403-408	6	Month One Employment	Right-justify, leading 0's.
409-414	6	Month Two Employment	Right-justify, leading 0's.

Position	Length	Data Element	Data Specification
415-420	6	Month Three Employment	Right-justify, leading 0's.
421-430	10	Total Wages	Right-justify, leading 0's.
431-432	2	Filler	Space-fill.
433-435	3	County Code	3-digit numeric code used to identify the county where the worksite is physically located
436-439	4	Township/Zone Code	Left-justified, trailing spaces; if state uses Township Codes, write 3-digit code used to identify the township of the worksite's physical location; if state uses Zone Codes, write 4-digit code used to identify the zone of the worksite's physical location; if the state uses neither, space-fill.
440-449	10	Phone Number	Respondent phone number
450-461	12	MWR Web ID	Space-fill, for RUN = 00000 records only.
462-469	8	MWR Web Password	Space-fill, for RUN = 00000 records only.
470-472	3	MOA - Foreign Country	Space-fill, for RUN = 00000 records only.
473-479	7	MOA - Foreign Postal Code	Space-fill, for RUN = 00000 records only.

424 Position MWR Print Contract Data File Format – Exported by print contractor and sent to the states

Position	Length	Data Element	Data Specification
1-2	2	Program Code	<u>Required.</u> A 2-digit program code indicating the type of data being reported. 02 = MWR
3	1	Record Type	<u>Required.</u> 5 = MWR or RFEW
4-5	2	Reference State	<u>Required.</u> The 2-digit state FIPS code indicating the location of the establishment.
6-15	10	UI Account Number	<u>Required.</u> The UI account number assigned to the employer by the state. Right-justified, zero-filled.
16-20	5	Reporting Unit Number	<u>Required.</u> The RUN number assigned by the state to distinguish between records with the same UI Account Number. Right-justified, zero-filled. This file only contains subunits, RUN > 00000.
21	1	Format Type	<u>Required.</u> D = Detail Type
22-30	9	Federal Employer Identification Number	The 9-digit EIN assigned to the employer by the IRS. Numeric, right-justified. Should be zero-filled if EIN is unknown.

Position	Length	Data Element	Data Specification
31-147	117	Filler	Space-filled.
148-151	4	Year	<u>Required.</u> The year of data collection to which the file's data reference.
152	1	Quarter	<u>Required.</u> The quarter of data collection to which the file's data reference.
153-222	70	Filler	Space-filled
223-228	6	Month One Employment	Right-justify, leading 0's.
229-234	6	Month Two Employment	Right-justify, leading 0's.
235-240	6	Month Three Employment	Right-justify, leading 0's.
241-250	10	Total Wages	Right-justify, leading 0's.
251-307	57	Filler	Space-filled.
308	1	Data Source Code	<u>Required.</u> P = Print.
309-424	116	Filler	Space-filled.

Various file formats received by the EDIC are provided next in this appendix, including the standard 350 position MWR reporter files: regular (non-PEO/PPF); PEO; and PPF. All data processed by the EDIC, regardless of the file format in which it was received at the EDIC, are exported to the states in the standard 424-position file EDIC export format shown at the beginning of this appendix.

Standard 799 MWR File Format Exported to the states via MWR Web (Collected Data file)

The data of firms who report via the MWR Web system are provided to the states by the national office/Division of Business Establishment Systems (DBES) in the 799 position file layout given below. This is known as the Collected Data file referred to in Section 4.8.

Position	Length	Data Element	Data Specifications
1-2	2	Program Code	02 = QCEW
3	1	Record Type (MWR Web = 6)	Record Type = 6
4-5	2	Reference State	<u>Required.</u> The 2-digit numeric FIPS code of the state.
6-15	10	UI Account Number	<u>Required.</u> The UI account number assigned to the employer by the state. Right-justified, zero-filled.
16-20	5	Reporting Unit Number	<u>Required.</u> The RUN assigned by the state to distinguish between records with the same UI Account Number. Right-justified, zero-filled.
21	1	Format Type	Format Type = D

Position	Length	Data Element	Data Specifications
22-30	9	Employer Identification Number	<u>Required.</u> The 9-digit EIN assigned to the employer by the IRS. Numeric, right-justified. Should be zero-filled if EIN is unknown.
31-65	35	Trade Name	<u>Required.</u> The division or subsidiary name of the establishment. "Mom's Restaurant" is an example of a trade name of ABC Enterprises. Left-justified, blank-filled.
66-100	35	Street Address	<u>Required.</u> The physical street address of the establishment. Abbreviate as necessary in accordance with the U.S. Postal Service's National Zip Code and Postal Service Directory. Left-justified, blank-filled.
101-130	30	City	<u>Required.</u> The city of the establishment. Left-justified, blank-filled.
131-132	2	State	<u>Required.</u> The standard 2-letter Postal Service state abbreviation for the establishment.
133-137	5	Zip Code	<u>Required.</u> The 5-digit Zip Code used by the Postal Service for the establishment.
138-141	4	Zip Code Extension	<u>Optional.</u> The 4-digit Zip Code Extension used by the Postal Service for the establishment. Blank-filled if not used.
142-143	2	Primary Comment Code	<u>Optional.</u> One of the standard 2-digit comment codes used to explain data values that differ substantially from previously reported data. Blank-filled if not used.
144-145	2	Secondary Comment Code	<u>Optional.</u> One of the standard 2-digit comment codes used to explain data values that differ substantially from previously reported data. Blank-filled if not used.
146-147	2	Third Comment Code	<u>Optional.</u> One of the standard 2-digit comment codes used to explain data values that differ substantially from previously reported data. Blank-filled if not used.
148-151	4	Reference Year	<u>Required.</u> The four digits of the calendar year covered by the report.
152	1	Reference Quarter	<u>Required.</u> The 1-digit number indicating the reference calendar quarter for the report. The calendar quarters are: 1 = January - March 2 = April - June 3 = July - September 4 = October - December
153-187	35	Legal Name	<u>Optional.</u> The legal or corporate name of the establishment. For example "ABC Enterprises"

Position	Length	Data Element	Data Specifications
			or "Smith Companies, Inc." Left-justified, blank-filled.
188-222	35	Worksite Description	<u>Required.</u> A meaningful, unique description of the establishment, such as store number or plant name (e.g., Store 101, Jones River Plant). Left-justified, blank-filled.
223-228	6	Month 1 Employment	<u>Required.</u> The number of all full- and part-time employees who worked during or received pay (subject to UI wages) for the pay period which includes the 12th of the month. Right-justified, zero filled.
229-234	6	Month 2 Employment	<u>Required.</u> The number of all full- and part-time employees who worked during or received pay (subject to UI wages) for the pay period which includes the 12th of the month. Right-justified, zero filled.
235-240	6	Month 3 Employment	<u>Required.</u> The number of all full- and part-time employees who worked during or received pay (subject to UI wages) for the pay period which includes the 12th of the month. Right-justified, zero filled.
241-250	10	Quarterly Wages	<u>Required.</u> The total amount of wages (both taxable and non-taxable) paid to employees during the entire reference quarter. Must be numeric (no \$ signs or commas). Must be right-justified and filled with leading zeros. Should be rounded to the nearest dollar (no cents). Should be zero-filled if no wages were paid.
251-307	57	Narrative Comment	Explanation of large changes in employment or wages due to store closure, layoffs, bonuses, seasonal changes.
308	1	Data Source Code	<u>Required.</u> The value is currently "W". This indicates data processed and edited via MWR Web.
309-311	3	County Fips Code	<u>Required for birth records.</u> 3-digit numeric Federal Information Processing Standard (FIPS) code used to identify each establishment location or place of business.
312-314	3	Township Code	<u>Required for birth records.</u> 3-digit numeric code required in New England States and New Jersey. Used to identify township of each establishment location or place of business.

Position	Length	Data Element	Data Specifications
315	1	Ownership Code (Births Only)	Required for birth records. 1-digit numeric code used to identify the economic ownership of the establishment.
316	1	Filler	1-digit numeric, assigned value is "5." (Formerly Auxiliary Code)
317-322	6	NAICS Code (Births Only)	Required for birth records. 6-digit numeric code used to identify the primary activity of the establishment.
323-326	4	Agent Code	Record Type 6
327-330	4	Initial Date of Liability – Year	The four-digit year of a firm's initial liability date. This is applicable to birth records.
331-332	2	Initial Date of Liability – Month	The two-digit month of a firm's initial liability date. This is applicable to birth records.
333-334	2	Initial Date of Liability – Day	The two-digit day of a firm's initial liability date. This is applicable to birth records.
335-338	4	End of Liability Date - Year	The four-digit year of a firm's end of liability date. This is applicable to death records.
339-340	2	End of Liability Date - Month	The two-digit month of a firm's end of liability date. This is applicable to death records.
341-342	2	End of Liability Date – Day	The two-digit day of a firm's end of liability date. This is applicable to death records.
343-492	150	Worksite Economic Activity Description	A description of the client worksite's economic activity. Economic activity is the principal business(es) in which the worksite is engaged.
493-527	35	MWR Contact	The contact's name. Left-justified, blank-filled.
528-562	35	Contact Title	The contact's job title. Left-justified, blank-filled.
563-597	35	Mailing Street Address Line 1	The line 1 mailing street address for the contact. Left-justified, blank-filled.
598-632	35	Mailing Street Address Line 2	The line 2 mailing street address for the contact. Left-justified, blank-filled.
633-662	30	Mailing Address - City	The mailing address city for the contact. Left-justified, blank-filled.
663-664	2	Mailing Address - State	The standard 2-letter Postal Service state abbreviation for the contact's mailing address.
665-669	5	Mailing Address – 5-digit ZIP Code	The 5-digit Zip Code used by the Postal Service for the contact's mailing address.
670-673	4	Mailing Address – 4-digit ZIP Code Extension	The 4-digit Zip Code Extension used by the Postal Service for the contact's mailing address. Blank-filled if not used.
674-676	3	Area Code	The contact's phone number area code.
677-679	3	Phone Prefix	The contact's phone number prefix.
680-683	4	Phone Suffix	The contact's phone number suffix.

Position	Length	Data Element	Data Specifications
684-688	5	Phone Extension	The contact's phone extension, if available. Left-justified, blank-filled.
689-698	10	Contact Fax	The contact's fax number, if available. No hyphens or parentheses.
699-758	60	Email Address	The contact's email address, if available. Left-justified, blank-filled.
759	1	Business Transfer Event Type 1	1 = "Acquired another company"
760	1	Business Transfer Event Type 2	2 = "Been sold to another company."
761	1	Business Transfer Event Type 3	3 = "Been in a merger"
762	1	Business Transfer Event Type 4	4 = "Reorganized"
763	1	Business Transfer Event Type 5	5 = "Opened a new UI account"
764-798	35	Business Transfer Company	
799	1	Collection Status	1 = No action required 2 = Mail indicator "Y" 3 = "Now is a single worksite account – state action required." 4 = "UI account no longer active." 5 or 6 = No action required

Appendix O – Central Collection Data Editing

This appendix describes in general terms the edits performed by the System for processing Large volume Employment Data (SLED) processing system used by the Electronic Data Interchange Center (EDIC). They are being presented so that state staff can better understand how their data are being processed by the EDIC before being provided to the state. (For a more comprehensive overview of the work performed at the EDIC, see Chapter 4 – Multiple Worksite Central Reporting.)

The SLED system edits closely resemble the following list of edits performed in the standard state systems and the BLS-Washington system. For detailed edit information on these edits, refer to – Edit Conditions and Formulas.

Edit Code	State/BLS System Edit
002	UI Account Number Check
003	Reporting Unit Number Check
004	Reference Year Check
005	Reference Quarter Check
006	State Code Check
010	NAICS Code Check
012	Ownership Code Check
013	County Code Check
016	Ownership/NAICS Conflict
031	First Month Employment Check
032	Second Month Employment Check
033	Third Month Employment Check
034	Total Wages Check
045	Federal Employer Identification Number Check
048	Comment Code Check
065	Inconsistent County and Township Codes Check
072	Blank Name Check
091	Large Monthly Employment Change Check
092	Large Wage Change Check
093	Employment Without Wages Check
094	Wages Without Employment Check
095	Wages/Employment Sum Check
102	Blank Physical Location City Check
103	Physical Location State Abbreviation Check
104	Physical Location Zip Code Format Check
104	Physical Location Zip Code Extension Format Check
126	Monthly Employment Change Check
127	Wage Change Check
128	Identical Monthly Employment Check

This appendix provides specific, detailed edit information only for those editing processes that SLED performs differently or that have no corresponding edits in the states and BLS-Washington, as well as some additional information.

Normal SLED Processing from Initial Load Through Export

The processing sequence of the SLED system is outlined below. SLED provides EDIC staff with the option of performing a crosswalk, which is needed when employers do not provide UI Account Numbers (UIs) and/or Reporting Unit Numbers (RUNs). Steps 2 and 3 are only performed if the crosswalk processing is used. If the crosswalk option is not used, SLED moves from the pre-edits (step 1) directly into single unit processing (step 4).

1. **Pre-Edits** – Pre-edit checks are performed to flag invalid state FIPS codes, missing unique crosswalk/worksites identifiers as well as non-numeric employment and wages
2. **Crosswalk Matching** – SLED assigns a UI and RUN to each record using linking information built into the reporter’s crosswalk information. SLED performs the linking process by matching a unique worksite identifier on the reporter's file with the company identifier on their crosswalk information. If a match is found, SLED copies the UI and RUN from the reporter’s crosswalk information onto the appropriate record on the reporter file.
3. **Single Unit Identification** – The system identifies and displays potential single-unit records on the reporter’s file. This applies to private sector reporters only. For private sector employers, SLED does not accept zero-filled RUNs; however, government reporters may have zero-filled RUNs.
4. **Aggregation** – Data of records having an identical combination of state FIPS code, UI, and RUN are aggregated into a single record. This step is needed because some reporters provide data at a sub-establishment level (for example, for store departments rather than for the entire store). If the reporter file received is from a Professional Employer Organization (PEO), any client data of the PEO are also copied to a “PEO client table” which holds the client data. This step is done immediately after aggregation processing is completed. The client data are later used as part of building the state export files during the exporting process.
5. **Missing Record Identification/Processing** – The system identifies and displays records that are potentially missing/out-of-business. Typically, these are records not present on the file submitted by the reporter for the current quarter but were present on the same reporter file for the previous quarter. Records that are truly out-of-business can be added back to the reporter’s file for the current quarter along with a comment code of 86 (establishment permanently out-of-business) for export and identification to the state. Other missing record situations may involve comment code 88 (establishment dissolution) or 18 (active employer reporting zero employment and wages) or 93 (record has a successor UI/RUN).
6. **Detail Edits** – Detail edits are performed to check the validity of fields on the reporter file and to compare fields for consistency.
7. **Interquarter Editing of Employment and Wages** – The system performs interquarter edits for employment and wages using the reporter file and historical reporter data (data collected by the EDIC for that reporter in previous quarters).

8. Employment Warning Edits – The analyst will select and run Employment Warnings editing. SLED performs editing on employment fields to check for unusual fluctuations in the current quarter firm record. Current quarter and historical employment data are used in this editing. SLED lists any current quarter firm record flagged for review and processing.
9. Birth Record Processing – The system identifies and edits birth records (records on the current quarter reporter file but not on earlier quarters). Birth records carry the classification codes (including NAICS, County/Township, and Ownership codes) and appropriate comment code (85 = new establishment or worksite, or 90 = reporter changes basis of reporting – greater detail) needed to set up the new reporting units in the state.
10. Non-Wage, Non-Employment Interquarter Editing – SLED checks for content changes in fields other than wages and monthly employments (name and address fields, Employer Identification Number (EIN), and Reporting Unit Description). The system compares these fields using current and prior quarter reporter records.
11. Detail Edits – Detail edits are performed a second time. Typically, at this stage, there are no critical detail edit errors to correct.
12. Single Unit Identification – The system identifies and displays potential single-unit records a second time on the reporter's file. This applies to private sector reporters only. For private sector employers, SLED does not accept zero-filled RUNs; however, government reporters may have zero-filled RUNs.
13. Reporter Data to Export Work Table – Once all editing is finished, SLED moves the reporter's data to an export work holding table for later transmission to states.
14. Export – Data are exported to the states using the first export file format (424 positions) shown in Appendix N – MWR File Formats. Predecessor/successor data are also exported within State export files if entered by the EDIC prior to the exporting process.

General Differences Between SLED and the State/BLS Systems

- With few exceptions, SLED does not allow data to be processed to completion and exported to the states until records with edit flags are either fixed or explained. Invalid data must be corrected, while suspect data must be explained with an appropriate comment code (sometimes accompanied by a narrative comment).
- Back quarter data available during SLED processing may differ from back quarter data available during state processing for employers who recently switched to EDIC reporting. Generally speaking, the EDIC only receives, processes, and exports current quarter data. However, states routinely update and process back quarter data that were reported late. States may have more accurate or complete back quarter data for employers who make the transition to the EDIC. Differences in back quarter data could occasionally lead to different editing results in the interquarter edits for employment and wages.
- Records submitted to the EDI Center have only one address, a physical location address. In the state and BLS systems, records may have up to three addresses: physical location address, Mailing/other address, and UI address. The address edit in the state and BLS systems requires that each record must contain one clean address that meets postal regulations. (See

edit 070 in Appendix F.) In SLED, it is possible for a record to pass editing when all of the address fields are blank.

- The Multiple Worksite Report (MWR) data processed through SLED do not include a number of data elements present in the state systems, such as Taxable Wages, Contributions, Type of Coverage Code, and Status Code. All SLED data are presumed to describe active, covered reporting units.
- Some parameters in SLED are tighter than the parameter defaults in the state systems. This situation can explain why a record fails a state edit but does not have an EDI provided comment code.

In addition, SLED performs two edits (see Consistency Edits later in this chapter) that are not included in the state and BLS systems. For several other edits, SLED screens data more stringently than the state and BLS systems. For example, several SLED edits do not use the employment cutoff parameters that allow comparable edits in the state and BLS systems to bypass records with low employment. In other words, SLED flags some records that would not flag in the states or BLS.

SLED Pre-edits

The purpose of the pre-edits is to check for critical errors in key fields. SLED flags these errors in the pre-edits:

Edit Code	State/BLS System Edit Message
002	Invalid UI Account Number
003	Invalid Reporting Unit Number
004	Invalid Reference Year
005	Invalid Reference Quarter
006	Invalid State Code
031	Invalid First Month Employment
032	Invalid Second Month Employment
033	Invalid Third Month Employment
034	Invalid Total Wages

If a crosswalk is used to process the reporter's file and assign UI Account Numbers or Reporting Unit Numbers, the edits for those two fields are not performed until after crosswalk processing is completed.

SLED allows the RUN field to be alphanumeric and to contain all nines; however, the field is changed to appropriate number values during crosswalk processing. The state and BLS systems require the RUN field to be numeric only and do not permit the field to contain all nines. See edit 003. For private sector employers, SLED does not export zero-filled RUNs; however, the National Finance Center (NFC), Department of Defense (DoD), and other Federal government establishments may have zero-filled RUNs.

Detail Edits

SLED runs the detail edits after the pre-edits and the crosswalk matching process. The detail edits are composed of data type, range, and value checks of a particular field within each record. The SLED detail edits flag the same conditions as these state/BLS edits:

Edit Code	State/BLS System Edit Message
045	Invalid Federal EI Number
048	Invalid Comment Code
072	Both Trade Name and Legal Name are Blank
102	Blank Physical Location City; Other PLA Fields Present
103	Unusable Physical Location State Abbreviation
104	Unusable Physical Location Zip Code Format

In addition, SLED screens the address block in a manner similar to state/BLS edit 114, the Physical Address Format Check. The record is flagged if the street address line contains a Post Office Box or drawer lock box. SLED also compares the state abbreviation to the state FIPS code (for example, if the FIPS code is 17 (Illinois), the state abbreviation should be IL). However, this is not a critical edit and does not require correction for SLED to continue processing. Some worksite records contain the address of the company's headquarters, which may be in a different state. The state and BLS systems have three address blocks, and can use the Mailing/Other address block for such cases. SLED has only one address block, which is presumed to be a physical location address. The EDIC is unable to collect a physical location address on some occasions (for example, when a group of employees are not assigned to any specific, fixed location) and accepts a headquarters address instead. For this reason, inconsistencies between state FIPS codes and state abbreviations are flagged only as warnings.

SLED also screens the comment codes to ensure that the same code is not used in more than one comment code field. Comment code 99 is not permitted unless a narrative comment is present.

Beginning several quarters after the reporting unit's Setup Date, the state and BLS systems assign a Warning (W) flag to UI accounts with significant employment and zero-filled EINs. (See edit 116 in Appendix F.) Though the SLED system permits records of zero filled EINs to be exported, as a matter of policy the EDIC will not send the data without valid EINs.

Consistency Edits

The consistency edits are run as part of the detail edits. The consistency edits are composed of relationship checks between fields of the same record. Several of these edits use parameters from the State Abbreviation Table located within SLED. (See State Parameters later in this appendix.) The consistency edits check the reporter file for the following:

1. State physical location – The state abbreviation is compared to the state FIPS code (e.g. if the state FIPS code is 17 (Illinois), then the state abbreviation is expected to be IL). However, this is not a critical edit in SLED and does not need to be corrected to pass detail edits. This is because the EDIC is unable to collect a physical location address on some occasions (for example, when a group of employees are not assigned to any specific, fixed location) and accepts a headquarters address instead.
2. Monthly Employment
 - A record is flagged if employment for all three months is zero when wages are greater than the Quarterly Wages Parm (parm default = 10,000).
3. Quarterly Wages
 - A record is flagged when wages are zero when average monthly employment is greater than the average monthly employment (AME) Parm (parm default =10).
 - A record is flagged when wages minus the sum of month 1 employment + month 2 employment + month 3 employment are less than the AME Tolerance Parm (parm default = 5). SLED will only perform the edit if average monthly employment is greater than the AME Tolerance Parm.

In addition, SLED performs two edits that are not mechanically performed in the states or BLS-Washington:

1. Monthly employment flags if month 1 employment, month 2 employment, month 3 employment, and quarterly wages are all = 0.
2. Total wages flag if the average weekly wage is very low (less than \$8.00). The system calculates average weekly wages for a 13 week quarter – quarterly wages are divided by the average monthly employment and then divided by 13.
$$(\text{Wages/Quarter}) \div (\text{Average Number of Workers}) \div (13 \text{ Weeks/ Quarter}) = \text{Wages per Employee per Week}$$
The system does not perform this edit when wages equal zero or when employment equals zero.

Records flagged by the consistency edits can be processed to completion if given a proper comment code.

State Parameters

The SLED system uses a table of parameters during editing called the State Abbreviation Table. Each state's parameters may be adjusted separately. Table 1 below lists parameters/tolerances that are used during the consistency edits phase. In addition, eight parameters and tolerances on the State Parameters Table are used specifically during the interquarter edits for employment and wages. These parameters and tolerances are listed in Table 2.

Table 1. Detail Edit Parameters/Tolerances

SLED Parm	State System Parm	SLED Edit	EXPO PK #	WIN PK #
No Total Wages with AME Cutoff (default = 10)	NO-WAGE-MAX-EMPL (default = 10)	Flags zero wages when average monthly employment (AME) is greater than this parm. Corresponds to State/BLS edit 130.	008	011
Quarterly Wages Parm (default = 10,000)	NO-EMPL-MAX-WAGE (default = 25,000)	Flags zero employment for all three months when wages are greater than this parm. Corresponds to State/BLS edit 131.	007	015
Employment Equals Total Wages Tolerance (default = 5)	EMPL-EQ-WAGE-TOL (default = 5)	The monthly wage check flags records with absolute difference between wages and the sum of month1, month2, and month3 employment less than this parm. Corresponds to State/BLS edit 132.	041	017
Employment Equals Total Wages AME Cutoff (default = 25)	EMPL-EQ-WAGE-AME (default = 50)	The monthly wage check is performed only when the record's average monthly employment is above this parm. Corresponds to State/BLS edit 132.	042	018

Interquarter Edits

Interquarter edits for employment and wages are performed on the reporter file after the initial detail edit process is completed. The edits used by SLED during this phase of processing closely resemble the following edits performed in the state and BLS systems:

Edit Code	State/BLS System Edit Message
091	Employment Change Greatly Exceeds Test Parameters
092	AQW Change is Significantly > Parm and Exceeds Twice the Quartile AQW Range
126	Employment Change Exceeds Test Parameters
127	AQW Change > Parm and Exceeds Twice the Quartile AQW Range
128	Identical Monthly Employment > Parm

SLED uses data reported to the EDIC in prior quarters as the historical data for performing interquarter edits. If the reporter file has less than four consecutive quarters of historical data, the record automatically passes the interquarter edits. Birth records (i.e., those with no historical data) also pass these edits automatically. After non-wage/non-employment interquarter editing, SLED cycles the reporter file back through detail editing a final time, checking for any remaining detail edit errors and permitting correction of errors as necessary.

Records flagged by these interquarter edits can be processed to completion if given a proper comment code. In addition, comment code 98 (data verified by EDIC) can also be assigned by the EDIC to records flagged during these interquarter edits. They can only use it during this stage of SLED processing. It cannot be used to pass reporter records with other types of errors.

Table 2. Interquarter Edit Parameters and Tolerances

SLED Parm	State System Parm	SLED Edit	EXPO PK #	WIN PK #
Split Level for Employment Difference (Default = 20)	EMPL-DIFF-SPL-AME (Default = 20)	Interquarter edit for employment fluctuations; used to check seasonal fluctuations and seasonality. Corresponds to State/BLS edits 091 and 126.	010	005
Low Employment Maximum Employment Difference (Default = 10)	LOW-EMPL-MAX-DIFF (Default = 10)	Interquarter edit for employment fluctuations; used to check differences on an absolute basis and seasonal fluctuations on an absolute basis. Corresponds to State/BLS edits 091 and 126.	011	006

SLED Parm	State System Parm	SLED Edit	EXPO PK #	WIN PK #
High Employment Maximum Employment Difference (Default = 30)	HIGH-EMPL-MAX-DIFF (Default = 30)	Interquarter edit for employment fluctuations; used to check differences on an absolute basis and seasonal fluctuations on an absolute basis. Corresponds to State/BLS edits 091 and 126.	012	007
High Reporting Percent Change (Default = 10)	HIGH-REPORTING-PCT-CHG (Default = 10)	Interquarter edit for employment fluctuations; used to check differences on a percent basis and seasonal fluctuations on a percent basis. Corresponds to State/BLS edits 091 and 126.	013	008
Reporting Percent Change (Default = 30)	REPORTING-PCT-CHG (Default = 30)	Interquarter edit for employment fluctuations; used to check differences on a percent basis and seasonal fluctuations on a percent basis. Corresponds to State/BLS edits 091 and 126.	014	009
Employment Check Multiplier (Default = 10)	EMPL-CHECK-MULTIPLIER (Default = 10)	This parm is used to determine the severity of the edit flag. Corresponds to State/BLS edits 091 and 126.	053	010
Wage Change Cutoff (Default = 10,000)	WAGE-CHG-CUTOFF (Default = 10,000)	Interquarter wage edit. Corresponds to State/BLS edits 092 and 127.	019	012

SLED Parm	State System Parm	SLED Edit	EXPO PK #	WIN PK #
Wage Check Multiplier (Default = 3)	WAGE-CHECK-MULTIPLIER (Default = 3)	This parm is used to determine the severity of the edit flag. Corresponds to State/BLS edits 092 and 127.	059	013

Birth Record Edits

Three files are used during birth record processing.

1. Reporter file – This file contains the current reporter data to be processed.
2. Historical Employment file – Records on the Reporter Work File are compared to the records on this file. No matches indicate a birth record.
3. Birth file – Contains a list of all birth records processed by SLED.

After SLED completes the interquarter employment and wage edits, it identifies births submitted on the reporter file. SLED does this by comparing the state FIPS Code, UI Account Number, and Reporting Unit Number (state FIPS-UI-RUN combination) of each record on the reporter file to the same fields of records located on the Historical Employment file. (The Historical Employment file contains up to five quarters of data.) Each record on the reporter file that does not have a corresponding record on the Historical Employment file with an identical state FIPS-UI-RUN combination is considered a birth record by SLED. EDIC staff assign classification codes to birth records, and these codes are screened by the birth record edits. The SLED birth record edits flag the same conditions as these state/BLS edits:

Edit Code	State/BLS System Edit Message
010	Invalid NAICS Code
012	Invalid Ownership Code
013	Invalid County Code
016	NAICS & Ownership Inconsistent
065	Inconsistent County/Township Combination

Birth records flagged for any of these errors cannot complete processing until they are corrected. In addition, the EDIC assigns a comment code of 85 (new establishment or worksite) or 90 (reporter changes basis of reporting – greater detail) to birth records to identify them as new worksites to the State.

Non-Wage, Non-Employment Interquarter Checks

After birth edits are completed, SLED then proceeds to the interquarter check for non-wage and non-employment fields. The non-wage, non-employment check applies to private companies only. There are no comparable edits in the state or BLS systems. This stage checks for changes in information on nine fields that do not include economic data:

EIN	Trade Name	Legal Name
Street Address	City	State Abbreviation
Zip Code	Zip Code Extension	Reporting Unit Description

For each of these fields, SLED compares the current information (located on the reporter file) with the previous quarter's information (located on SLED's Historical Address Table). SLED allows the data processing staff to view and/or resolve any discrepancies discovered during the comparison. For each of the nine data fields compared, SLED gives the data processing staff three options:

1. Accepting the data values from the current quarter's data.
2. Accepting the data values from the previous quarter's data.
3. Updating the current quarter data field, if flagged for being different than the previous quarter, with updated information.

The current reporter file must contain records of companies located on the Historical Address Table for these edits to take place. Reporters submitting data for the first time to the EDIC do not meet this requirement and the edits are not performed on their record.

Appendix P – NAICS Aggregation Tree

The North American Industry Classifications and their descriptions are available in the QCEW BLS NAICS search application located on the BLS website.

The NAICS aggregation tree below, displays the connection between the most common data aggregations by industry. States may find it helpful to use these aggregations in their own publications.

Domain	Supersector	Sector	Code
	Total, All Industries		10
	Goods-Producing Industries		101
	Natural Resources and Mining		1011
		Agriculture, forestry, fishing and hunting	11
		Mining	21
	Construction		1012
		Construction	23
	Manufacturing		1013
			31-
		Manufacturing	33
	Service-Providing Industries		102
	Trade, Transportation, and Utilities		1021
		Wholesale trade	42
			44-
		Retail trade	45
			48-
		Transportation and warehousing	49
		Utilities	22
	Information		1022
		Information	51
	Financial Activities		1023
		Finance and insurance	52
		Real estate and rental and leasing	53
	Professional and Business Services		1024
		Professional and technical services	54
		Management of companies and enterprises	55
		Administrative and waste services	56
	Education and Health Services		1025
		Educational services	61
		Health care and social assistance	62
	Leisure and Hospitality		1026
		Arts, entertainment, and recreation	71
		Accommodation and food services	72
	Other Services		1027
		Other services, except public administration	81

Public Administration	1028
Public administration	92
Unclassified	1029
Unclassified	99

Appendix Q – ARS Refiling Codes

The Annual Refiling Survey (ARS) Response Code field on the Control File shows the status of the record as it progresses through the refiling cycle. Each record included in the ARS always has an ARS Response Code. Two ARS Response Codes are included in the systems: the response code assigned to the record from the most recently completed refiling for that account and the “future” response code of the refiling cycle in progress. The refile year and “future” refile year are included for each response code. A Collection Mode Indicator (CMI) is also assigned to records for the current refiling cycle to indicate that a record was collected through the ARS Web system. As of the 2018 refiling cycle, CMI codes are updated when states load the CARS Response Code Files.

At the conclusion of the ARS, the state system copies each record's Collection Mode Indicator, ARS Response Code, and ARS Refile Year to subsequent EQUI files. Future response codes and refile year equal the information from the refiling cycle in progress or just completed prior to building the next control file.

The valid values for the ARS Response Codes are listed below.

Code	Definition
<i>Non-respondents</i>	
blank	State default value, for records not included in the survey
00	Account included in normal annual ARS email and mailings
01-04	Accounts selected for QCEW Research Projects/Panels
11	Clean subunit record in a mailable multi
12	Clean record in a multi, but unmailable due to errors on another record
86	Record on the control file but either not mailed or not re-mailed; non-respondents excluded from response rates
98	Carryover non-respondent from prior refiling; no longer used
99	Unmailable due to errors (single, master, or subunit)
<i>Responses – Unusable Response</i>	
30	CCS I-error on both the state and BLS Micro file
31	Record not reviewed, pending
32	Industry information centrally collected by BLS
33	BLS-assigned, submitted as 46 or 50, but has a CCS I-error on BLS Micro file
34	BLS-assigned, submitted as 46 or 50, but doesn't have a true code change on BLS Micro File
35	BLS-assigned, submitted with Comment Code 81 and a true code change but not with a Response Code of 30, 46 or 50
63	Post Office return
64	Out of Business
65	Refusal

<i>Responses – Usable Response or System-assigned Codes</i>	
41	Reviewed, no refiling changes (no NAICS, county, township (New England or New Jersey only) or ownership change) on a single or subunit record. Response Code 41 is also assigned to a reviewed master record (MEEI =2) with or without any code changes. This code is also used for refiling records that changed from unclassified to classified area where the NAICS is unchanged.
42	Employer misunderstood industry description but codes are correct.
43	TRS respondent to ARS refiling. (no longer assigned after 2003).
46	Clean record with CCS updates from the ARS refiling. Noneconomic code change made to NAICS, county, township (New England and New Jersey only) or ownership.
50	Code changes from non-refiling sources. Noneconomic code change made to NAICS, county, township (New England and New Jersey only) or ownership but not from the ARS refiling.
57	Code changes from non-refiling sources. (no longer assigned after 2007)
76	Code change to industry code, county, township (New England and New Jersey only) or ownership also results in a NAICS 2007 code assignment. (no longer assigned after 2007)
77	2007 NAICS code assigned during refiling but with no correction to the 2002-based NAICS code. (no longer assigned after 2007)
78	NAICS code system-assigned (no longer assigned after 2001)
79	NAICS code system-assigned based on known business activities (no longer assigned after 2001)

The valid values for the Collection Mode Indicator (CMI) are listed below.

Collection Mode Indicator (CMI) Codes	
Code	Brief Definition
	<i>Refiling CMI's</i>
00	Record in current refiling
01-04	Special research panels
10	ARS responses
11-14	Special research panel responses

Appendix R – ARS Management Report and File Layout

States and regional offices use the Summary Management Report (SMR) to monitor the status of the Annual Refiling Survey (ARS). Refer to Chapter 6 for more details.

The SMR provides the following information:

- Counts and percentages by response code by single/subunits
- Total and usable response rates
- Information on code changes
 - Response rates by size class
 - Response rates by NAICS Sector
 - Number and percentage of NAICS changes only
 - Number and percentage of location changes only
 - Number and percentage of NAICS and location changes
 - Total number and percentage of code changes

The standard state processing systems (EXPO and WIN-202) generate the file format and the report format. EXPO states run job EARJ106M. WIN-202 states run the ARCS Management Report (under Listings) in the Reports screen/Reports tab.

States submit the SMR to their regional offices by the 25th of each month or earlier if the 25th falls on a weekend or a holiday. Regional office emails both the file format and the report format to the Office of Field Operations (OFON) by the 25th of each month. States should contact their regional offices to determine the method in sending these files and the frequency (i.e., every month or only during the annual refiling cycle).

For DMA EXPO States, regional offices can obtain these outputs by:

- Email from states
- Attachmate Reflection FTP software
- DBES routes the report format outputs to a local server (but not the file format)
- A combination of the above

For non-DMA EXPO and WIN-202 states, the only method is sending an email to the regional office.

The file format is listed below. All fields are numeric. Fields that give percentages or rates are five positions long, with two of the five positions implied to the right of the decimal place. For example, a value of 08934 in a percent field represents 89.34%. Date fields are eight positions long, including a four-digit year. For EXPO states only, the total figures (positions 441-466) on the file format have higher numbers than what is shown on the report format due to including Response Code (RC) 32, while the report format excludes the counts for RC 32. OFON uses the file format to generate their numbers and percentages.

See the report format (EXPO and WIN-202) in EXHIBIT R at the end of this section.

ARS Management Report		
Positions	Data Element	Length
1 - 8	Date of report (YYYY/MM/DD)	8
9 - 16	Date of previous report (YYYY/MM/DD)	8
17 - 18	State FIPS Code	2
UI Accounts (19-39)		
19 - 25	Number of UI accounts for the first email blasts or mailings	7
26 - 32	Filler (blank spaces)	7
33 - 39	Filler (blank spaces)	7
Printing Dates (40-110)		
40 - 46	Number of NVM Forms in First Printing	7
47 - 54	Date of 1st printing, NVS (YYYY/MM/DD)	8
55 - 62	Date of 1st printing, NVM (YYYY/MM/DD)	8
63 - 70	Date of 2nd printing, NVS (YYYY/MM/DD)	8
71 - 78	Date of 2nd printing, NVM (YYYY/MM/DD)	8
79 - 86	Date of 3rd mailing, NVS (YYYY/MM/DD)	8
87 - 94	Date of 3rd printing, NVM (YYYY/MM/DD)	8
95 - 102	Date of 4th printing, NVS (YYYY/MM/DD)	8
103 - 110	Date of 4th printing, NVM (YYYY/MM/DD)	8
Response Codes (111-414)		
<i>Code 41 (111-129)</i>		
111 - 115	Percent of total, response code 41	5
116 - 122	Number of singles, response code 41	7
123 - 129	Number of subunits, response code 41	7
<i>Code 42 (130-148)</i>		
130 - 134	Percent of total, response code 42	5
135 - 141	Number of singles, response code 42	7
142 - 148	Number of subunits, response code 42	7
<i>Code 46 (149-167)</i>		
149 - 153	Percent of total, response code 46	5
154 - 160	Number of singles, response code 46	7
161 - 167	Number of subunits, response code 46	7
<i>Code 50 (168-186)</i>		
168 - 172	Percent of total, response code 50	5

ARS Management Report		
Positions	Data Element	Length
173 - 179	Number of singles, response code 50	7
180 - 186	Number of subunits, response code 50	7
<i>Code 30 (187-205)</i>		
187 - 191	Percent of total, response code 30	5
192 - 198	Number of singles, response code 30	7
199 - 205	Number of subunits, response code 30	7
<i>Code 31 (206-224)</i>		
206 - 210	Percent of total, response code 31	5
211 - 217	Number of singles, response code 31	7
218 - 224	Number of subunits, response code 31	7
<i>Code 63 (225-243)</i>		
225 - 229	Percent of total, response code 63	5
230 - 236	Number of singles, response code 63	7
237 - 243	Number of subunits, response code 63	7
<i>Code 64 (244-262)</i>		
244 - 248	Percent of total, response code 64	5
249 - 255	Number of singles, response code 64	7
256 - 262	Number of subunits, response code 64	7
<i>Code 65 (263-281)</i>		
263 - 267	Percent of total, response code 65	5
268 - 274	Number of singles, response code 65	7
275 - 281	Number of subunits, response code 65	7
<i>Codes 00-11 (282-300)</i>		
282 - 286	Percent of total, response codes 00-11	5
287 - 293	Number of singles, response codes 00-11	7
294 - 300	Number of subunits, response codes 00-11	7
<i>Code 01 (301-319)</i>		
301 - 305	Percent of total, response code 01	5
306 - 312	Number of singles, response code 01	7
313 - 319	Number of subunits, response code 01	7

ARS Management Report		
Positions	Data Element	Length
<i>Code 02 (320-338)</i>		
320 - 324	Percent of total, response code 02	5
325 - 331	Number of singles, response code 02	7
332 - 338	Number of subunits, response code 02	7
<i>Code 03 (339-357)</i>		
339 - 343	Percent of total, response code 03	5
344 - 350	Number of singles, response code 03	7
351 - 357	Number of subunits, response code 03	7
<i>Code 04 (358-376)</i>		
358 - 362	Percent of total, response code 04	5
363 - 369	Number of singles, response code 04	7
370 - 376	Number of subunits, response code 04	7
<i>Codes 12-99 (377-395)</i>		
377 - 381	Percent of total, response codes 12-99	5
382 - 388	Number of singles, response codes 12-99	7
389 - 395	Number of subunits, response codes 12-99	7
<i>Code 98 (396-414)</i>		
396 - 400	Percent of total, response code 98	5
401 - 407	Number of singles, response code 98	7
408 - 414	Number of subunits, response code 98	7
<i>Nonrespondents (415-440)</i>		
415 - 419	Percent of total, nonrespondents, excluding master records	5
420 - 426	Number of singles, nonrespondents	7
427 - 433	Number of subunits, nonrespondents	7
434 - 440	Total number of nonrespondents	7
<i>Total (441-466)</i>		
441 - 445	Percent of all refiled establishments	5
446 - 452	Total number of single establishments involved in the refiling	7
453 - 459	Total number of worksite sub-units involved in the refiling	7
460 - 466	Total number of establishments (singles plus sub-units) involved in the refiling	7

ARS Management Report		
Positions	Data Element	Length
Response Rates (467 - 546)		
<i>Usable Response Rate (467-506)</i>		
467 - 471	Usable response rate all, units	5
472 - 476	Usable response rate all, employment	5
477 - 481	Usable response rate singles, units	5
482 - 486	Usable response rate singles, employment	5
487 - 491	Usable response rate subunits, units	5
492 - 496	Usable response rate subunits, employment	5
497 - 501	Filler (blank spaces)	5
502 - 506	Filler (blank spaces)	5
Total Response Rate (507-546)		
507 - 511	Total response rate all, units	5
512 - 516	Total response rate all, employment	5
517 - 521	Total response rate singles, units	5
522 - 526	Total response rate singles, employment	5
527 - 531	Total response rate subunits, units	5
532 - 536	Total response rate subunits, employment	5
537 - 541	Filler (blank spaces)	5
542 - 546	Filler (blank spaces)	5
Filler (547 – 630)		
<i>(Previously Carryover Nonresponse Rates 547 – 567)</i>		
547 - 553	Filler (blank spaces)	7
554 - 560	Filler (blank spaces)	7
561 - 567	Filler (blank spaces)	7
Filler (Previously Carryover Usabe Responses 568 574)		
568 - 574	Filler (blank spaces)	7
575 - 581	Filler (blank spaces)	7
582 - 588	Filler (blank spaces)	7
Filler (Prviously Carryover Unusable Responses 589 – 609)		
589 - 595	Filler (blank spaces)	7
596 - 602	Filler (blank spaces)	7
603 - 609	Filler (blank spaces)	7

ARS Management Report		
Positions	Data Element	Length
<i>Filler (Pending Carryover Pending 610 – 630)</i>		
610 - 616	Filler (blank spaces)	7
617 - 623	Filler (blank spaces)	7
624 - 630	Filler (blank spaces)	7
Response Rate and Ranges (631 - 868)		
<i>Size Range 0 (631-664)</i>		
631 - 635	Total response rate, size range (0), units	5
636 - 640	Total response rate, size range (0), employment	5
641 - 645	Usable response rate, size range (0), units	5
646 - 650	Usable response rate, size range (0), employment	5
651 - 657	Total size range (0), units	7
658 - 664	Total size range (0), employment	7
<i>Size Range 1-9 (665-698)</i>		
665 - 669	Total response rate, size range (1-9), units	5
670 - 674	Total response rate, size range (1-9), employment	5
675 - 679	Usable response rate, size range (1-9), units	5
680 - 684	Usable response rate, size range (1-9), employment	5
685 - 691	Total size range (1-9), units	7
692 - 698	Total size range (1-9), employment	7
<i>Size Range 10-49 (699-732)</i>		
699 - 703	Total response rate, size range (10-49), units	5
704 - 708	Total response rate, size range (10-49), employment	5
709 - 713	Usable response rate, size range (10-49), units	5
714 - 720	Usable response rate, size range (10-49), employment	5
719 - 725	Total size range (10-49), units	7
726 - 732	Total size range (10-49), employment	7
<i>Size Range 50-99 (733-766)</i>		
733 - 737	Total response rate, size range (50-99), units	5
738 - 742	Total response rate, size range (50-99), employment	5
743 - 747	Usable response rate, size range (50-99), units	5
748 - 752	Usable response rate, size range (50-99), employment	5
753 - 759	Total size range (50-99), units	7
760 - 766	Total size range (50-99), employment	7

ARS Management Report		
Positions	Data Element	Length
<i>Size Range 100-249 (767-800)</i>		
767 - 771	Total response rate, size range (100-249), units	5
772 - 776	Total response rate, size range (100-249), employment	5
777 - 781	Usable response rate, size range (100-249), units	5
782 - 786	Usable response rate, size range (100-249), employment	5
787 - 793	Total size range (100-249), units	7
794 - 800	Total size range (100-249), employment	7
<i>Size Range 250-999 (801-834)</i>		
801 - 805	Total response rate, size range (250-999), units	5
806 - 810	Total response rate, size range (250-999), employment	5
811 - 815	Usable response rate, size range (250-999), units	5
816 - 820	Usable response rate, range (250-999), employment	5
821 - 827	Total size range (250-999), units	7
828 - 834	Total size range (250-999), employment	7
<i>Size Range 1000+ (835-868)</i>		
835 - 839	Total response rate, size range (1000+), units	5
840 - 844	Total response rate, size range (1000+), employment	5
845 - 849	Usable response rate, size range (1000+), units	5
850 - 854	Usable response rate, size range (1000+), employment	5
855 - 861	Total size range (1000+), units	7
862 - 868	Total size range (1000+), employment	7
NAICS Sectors (869 - 1288)		
<i>NAICS Sector 11 (869-888)</i>		
869 - 873	Total response rate, NAICS Sector 11, units	5
874 - 878	Total response rate, NAICS Sector 11, employment	5
879 - 883	Usable response rate, NAICS Sector 11, units	5
884 - 888	Usable response rate, NAICS Sector 11, employment	5
<i>NAICS Sector 21 (889-908)</i>		
889 - 893	Total response rate, NAICS Sector 21, units	5
894 - 898	Total response rate, NAICS Sector 21, employment	5
899 - 903	Usable response rate, NAICS Sector 21, units	5
904 - 908	Usable response rate, NAICS Sector 21, employment	5

ARS Management Report		
Positions	Data Element	Length
<i>NAICS Sector 22 (909-928)</i>		
909 - 913	Total response rate, NAICS Sector 22, units	5
914 - 918	Total response rate, NAICS Sector 22, employment	5
919 - 923	Usable response rate, NAICS Sector 22, units	5
924 - 928	Usable response rate, NAICS Sector 22, employment	5
<i>NAICS Sector 23 (929-948)</i>		
929 - 933	Total response rate, NAICS Sector 23, units	5
934 - 938	Total response rate, NAICS Sector 23, employment	5
939 - 943	Usable response rate, NAICS Sector 23, units	5
944 - 948	Usable response rate, NAICS Sector 23, employment	5
<i>NAICS Sector 31-32-33 (949-968)</i>		
949 - 953	Total response rate, NAICS Sector 31-32-33, units	5
954 - 958	Total response rate, NAICS Sector 31-32-33, employment	5
959 - 963	Usable response rate, NAICS Sector 31-32-33, units	5
964 - 968	Usable response rate, NAICS Sector 31-32-33, employment	5
<i>NAICS Sector 42 (969-988)</i>		
969 - 973	Total response rate, NAICS Sector 42, units	5
974 - 978	Total response rate, NAICS Sector 42, employment	5
979 - 983	Usable response rate, NAICS Sector 42, units	5
984 - 988	Usable response rate, NAICS Sector 42, employment	5
<i>NAICS Sector 44-45 (989-1,008)</i>		
989 - 993	Total response rate, NAICS Sector 44-45, units	5
994 - 998	Total response rate, NAICS Sector 44-45, employment	5
999 - 1003	Usable response rate, NAICS Sector 44-45, units	5
1004 - 1008	Usable response rate, NAICS Sector 44-45, employment	5
<i>NAICS Sector 48-49 (1,009-1,028)</i>		
1009 - 1013	Total response rate, NAICS Sector 48-49, units	5
1014 - 1018	Total response rate, NAICS Sector 48-49, employment	5
1019 - 1023	Usable response rate, NAICS Sector 48-49, units	5
1024 - 1028	Usable response rate, NAICS Sector 48-49, employment	5

ARS Management Report		
Positions	Data Element	Length
<i>NAICS Sector 51 (1,029-1,048)</i>		
1029 - 1033	Total response rate, NAICS Sector 51, units	5
1034 - 1038	Total response rate, NAICS Sector 51, employment	5
1039 - 1043	Usable response rate, NAICS Sector 51, units	5
1044 - 1048	Usable response rate, NAICS Sector 51, employment	5
<i>NAICS Sector 52 (1,049-1,068)</i>		
1049 - 1053	Total response rate, NAICS Sector 52, units	5
1054 - 1058	Total response rate, NAICS Sector 52, employment	5
1059 - 1063	Usable response rate, NAICS Sector 52, units	5
1064 - 1068	Usable response rate, NAICS Sector 52, employment	5
<i>NAICS Sector 53 (1,069-1,088)</i>		
1069 - 1073	Total response rate, NAICS Sector 53, units	5
1074 - 1078	Total response rate, NAICS Sector 53, employment	5
1079 - 1083	Usable response rate, NAICS Sector 53, units	5
1084 - 1088	Usable response rate, NAICS Sector 53, employment	5
<i>NAICS Sector 54 (1,089-1,108)</i>		
1089 - 1093	Total response rate, NAICS Sector 54, units	5
1094 - 1098	Total response rate, NAICS Sector 54, employment	5
1099 - 1103	Usable response rate, NAICS Sector 54, units	5
1104 - 1108	Usable response rate, NAICS Sector 54, employment	5
<i>NAICS Sector 55 (1,109-1,128)</i>		
1109 - 1113	Total response rate, NAICS Sector 55, units	5
1114 - 1118	Total response rate, NAICS Sector 55, employment	5
1119 - 1123	Usable response rate, NAICS Sector 55, units	5
1124 - 1128	Usable response rate, NAICS Sector 55, employment	5
<i>NAICS Sector 56 (1,129-1,148)</i>		
1129 - 1133	Total response rate, NAICS Sector 56, units	5
1134 - 1138	Total response rate, NAICS Sector 56, employment	5
1139 - 1143	Usable response rate, NAICS Sector 56, units	5
1144 - 1148	Usable response rate, NAICS Sector 56, employment	5

ARS Management Report		
Positions	Data Element	Length
<i>NAICS Sector 61 (1,149-1,168)</i>		
1149 - 1153	Total response rate, NAICS Sector 61, units	5
1154 - 1158	Total response rate, NAICS Sector 61, employment	5
1159 - 1163	Usable response rate, NAICS Sector 61, units	5
1164 - 1168	Usable response rate, NAICS Sector 61, employment	5
<i>NAICS Sector 62 (1,169-1,188)</i>		
1169 - 1173	Total response rate, NAICS Sector 62, units	5
1174 - 1178	Total response rate, NAICS Sector 62, employment	5
1179 - 1183	Usable response rate, NAICS Sector 62, units	5
1184 - 1188	Usable response rate, NAICS Sector 62, employment	5
<i>NAICS Sector 71 (1,189-1,208)</i>		
1189 - 1193	Total response rate, NAICS Sector 71, units	5
1194 - 1198	Total response rate, NAICS Sector 71, employment	5
1199 - 1203	Usable response rate, NAICS Sector 71, units	5
1204 - 1208	Usable response rate, NAICS Sector 71, employment	5
<i>NAICS Sector 72 (1,209-1,228)</i>		
1209 - 1213	Total response rate, NAICS Sector 72, units	5
1214 - 1218	Total response rate, NAICS Sector 72, employment	5
1219 - 1223	Usable response rate, NAICS Sector 72, units	5
1224 - 1228	Usable response rate, NAICS Sector 72, employment	5
<i>NAICS Sector 81 (1,229-1,248)</i>		
1229 - 1233	Total response rate, NAICS Sector 81, units	5
1234 - 1238	Total response rate, NAICS Sector 81, employment	5
1239 - 1243	Usable response rate, NAICS Sector 81, units	5
1344 - 1248	Usable response rate, NAICS Sector 81, employment	5
<i>NAICS Sector 92 (1,249-1,268)</i>		
1249 - 1253	Total response rate, NAICS Sector 92, units	5
1254 - 1258	Total response rate, NAICS Sector 92, employment	5
1259 - 1263	Usable response rate, NAICS Sector 92, units	5
1264 - 1268	Usable response rate, NAICS Sector 92, employment	5

ARS Management Report		
Positions	Data Element	Length
<i>NAICS Sector 99 (1,269-1,288)</i>		
1269 - 1273	Total response rate, NAICS Sector 99, units	5
1274 - 1278	Total response rate, NAICS Sector 99, employment	5
1279 - 1283	Usable response rate, NAICS Sector 99, units	5
1284 - 1288	Usable response rate, NAICS Sector 99, employment	5
Changes (1,289 – 1,336)		
1289 - 1295	Number of code changes, NAICS only	7
1296 - 1300	Percentage of total code changes that are NAICS only	5
1301 - 1307	Number of code changes, location only	7
1308 - 1312	Percentage of total code changes that are location only	5
1313 - 1319	Number of code changes, NAICS and location	7
1320 - 1324	Percentage of total code changes, NAICS and location	5
1325 - 1331	Total CCS code changes	7
1332 - 1336	Percentage of total CCS code changes	5
Filler (Previously TRS 1337 – 1390)		
1337 - 1343	Filler (blank spaces)	5
1344 - 1348	Filler (blank spaces)	7
1349 - 1355	Filler (blank spaces)	7
1356 - 1362	Filler (blank spaces)	7
1363 - 1369	Filler (blank spaces)	7
1370 - 1376	Filler (blank spaces)	7
1377 - 1383	Filler (blank spaces)	7
1384 - 1390	Filler (blank spaces)	7
Date of Printing (1,391 – 1,570)		
<i>Date of First Printing (1,391 - 1,435)</i>		
1391 - 1398	Date of first NVS printing	8
1399 - 1405	Number of NVS Printed	7
1406 - 1413	Filler (blank spaces)	8
1414 - 1420	Filler (blank spaces)	7
1421 - 1428	Date of first NVM printing	8
1429 - 1435	Number of NVM printed	7
Date of Second Printing (1,436 - 1,480)		
1436 - 1437	Date of second NVS printing	8
1444 - 1450	Number of NVS Printed	7
1451 - 1458	Filler (blank spaces)	8
1459 - 1465	Filler (blank spaces)	7

ARS Management Report		
Positions	Data Element	Length
1466 - 1473	Date of second NVM printing	8
1474 - 1480	Number of NVM printed	7
<i>Date of Third Printing (1,481 - 1,525)</i>		
1481 - 1488	Date of third NVS printing	8
1489 - 1495	Number of NVS Printed	7
1496 - 1503	Filler (blank spaces)	8
1504 - 1510	Filler (blank spaces)	7
1511 - 1518	Date of third NVM printing	8
1519 - 1525	Number of NVM printed	7
<i>Date of Fourth Printing (1,526 - 1,570)</i>		
1526 - 1533	Date of fourth NVS printing	8
1534 - 1540	Number of NVS Printed	7
1541 - 1548	Filler (blank spaces)	8
1549 - 1555	Filler (blank spaces)	7
1556 - 1563	Date of fourth NVM printing	8
1564 - 1570	Number of NVM printed	7
<i>Filler (1,571 - 1,665)</i>		
1571 - 1665	Filler (blank spaces)	95

EXHIBIT R – EXPO ARS Management Report

PROGRAM: EARUT08 V9.05
 RUN DATE: MM/DD/YYYY
 RUN TIME: HH:MM:SS
 DATE OF PREVIOUS SUMMARY: MM/DD/YYYY

EARS SYSTEM - REFILEING PROCESSING
 ARS MANAGEMENT REPORT FOR XXSTATE

EARJ106M
 PAGE 1

TOTAL NUMBER OF UI ACCOUNTS PRINTED IN THE FIRST MAILOUT: 0 DATE OF 1ST MAILING: NVS NVM
 NUMBER OF UI ACCOUNTS PRINTED -: 0 DATE OF 2ND MAILING: NVS NVM
 : 0 DATE OF 3RD MAILING: NVS NVM
 NUMBER OF NVM IN FIRST PRINTING: 0 DATE OF 4TH MAILING: NVS NVM

RESPONSE STATUS	CODE	PERCENT OF TOTAL	SINGLES	SUBUNITS	TOTAL
USABLE RESPONSES --					
REVIEWED, NO CCS CHANGE, CODES CORRECT	(41)	XXX.XX%	X,XXX,XXX	X,XXX,XXX	X,XXX,XXX
EMPLOYER MISUNDERSTOOD THE INDUSTRY DESCRIPTION, CODES CORRECT	(42)	XXX.XX%	X,XXX,XXX	X,XXX,XXX	X,XXX,XXX
CLEAN RECORD WITH CCS UPDATES	(46)	XXX.XX%	X,XXX,XXX	X,XXX,XXX	X,XXX,XXX
CODE CHANGE FROM OTHER SOURCES	(50)	XXX.XX%	X,XXX,XXX	X,XXX,XXX	X,XXX,XXX
TOTAL USABLE RESPONSES		XXX.XX%	X,XXX,XXX	X,XXX,XXX	X,XXX,XXX
OTHER RESPONSES --					
UPDATES, BUT HAS CCS I-ERROR	(30)	XXX.XX%	X,XXX,XXX	X,XXX,XXX	X,XXX,XXX
NOT REVIEWED -- PENDING	(31)	XXX.XX%	X,XXX,XXX	X,XXX,XXX	X,XXX,XXX
POST OFFICE RETURN	(63)	XXX.XX%	X,XXX,XXX	X,XXX,XXX	X,XXX,XXX
OUT OF BUSINESS	(64)	XXX.XX%	X,XXX,XXX	X,XXX,XXX	X,XXX,XXX
REFUSAL	(65)	XXX.XX%	X,XXX,XXX	X,XXX,XXX	X,XXX,XXX
TOTAL OTHER RESPONSES		XXX.XX%	X,XXX,XXX	X,XXX,XXX	X,XXX,XXX
TOTAL ALL RESPONSES		XXX.XX%	X,XXX,XXX	X,XXX,XXX	X,XXX,XXX
NONRESPONDENTS					
MAILABLE, NOT YET MAILED	(00, 11)	XXX.XX%	X,XXX,XXX	X,XXX,XXX	X,XXX,XXX
MAILED ONCE	(01)	XXX.XX%	X,XXX,XXX	X,XXX,XXX	X,XXX,XXX
MAILED TWICE	(02)	XXX.XX%	X,XXX,XXX	X,XXX,XXX	X,XXX,XXX
MAILED THREE TIMES	(03)	XXX.XX%	X,XXX,XXX	X,XXX,XXX	X,XXX,XXX
MAILED FOUR TIMES	(04)	XXX.XX%	X,XXX,XXX	X,XXX,XXX	X,XXX,XXX
UNMAILABLE RECORDS	(12, 99)	XXX.XX%	X,XXX,XXX	X,XXX,XXX	X,XXX,XXX
TOTAL NONRESPONDENTS - NOT YET MAILED, MAILED, UNMAILABLE, ETC.		XXX.XX%	X,XXX,XXX	X,XXX,XXX	X,XXX,XXX
TOTAL NUMBER OF CONTROL FILE RECORDS (EXCLUDING MASTER RECORDS)			X,XXX,XXX	X,XXX,XXX	X,XXX,XXX

EXHIBIT R – EXPO ARS Management Report (continued)

USABLE RESPONSE RATE:	UNITS	EMPLOYMENT	TOTAL RESPONSE RATE:	UNITS	EMPLOYMENT
ALL	XXX.XX%	XXX.XX%	ALL	XXX.XX%	XXX.XX%
SINGLES	XXX.XX%	XXX.XX%	SINGLES	XXX.XX%	XXX.XX%
SUBUNITS	XXX.XX%	XXX.XX%	SUBUNITS	XXX.XX%	XXX.XX%

PROGRAM: EARUT08 V9.05
RUN DATE: MM/DD/YYYY
RUN TIME: HH:MM:SS

EARS SYSTEM - REFILEING PROCESSING
ARS MANAGEMENT REPORT FOR XXSTATE

EARJ106M
PAGE 2

RESPONSE RATES BY SIZE CLASS:	USABLE		TOTAL		TOTAL RECORDS	
	UNITS	EMPLOYMENT	UNITS	EMPLOYMENT	UNITS	EMPLOYMENT
SIZE RANGE (0)	XXX.XX%	XXX.XX%	XXX.XX%	XXX.XX%	X,XXX,XXX	X,XXX,XXX
SIZE RANGE (1-9)	XXX.XX%	XXX.XX%	XXX.XX%	XXX.XX%	X,XXX,XXX	X,XXX,XXX
SIZE RANGE (10-49)	XXX.XX%	XXX.XX%	XXX.XX%	XXX.XX%	X,XXX,XXX	X,XXX,XXX
SIZE RANGE (50-99)	XXX.XX%	XXX.XX%	XXX.XX%	XXX.XX%	X,XXX,XXX	X,XXX,XXX
SIZE RANGE (100-249)	XXX.XX%	XXX.XX%	XXX.XX%	XXX.XX%	X,XXX,XXX	X,XXX,XXX
SIZE RANGE (250-999)	XXX.XX%	XXX.XX%	XXX.XX%	XXX.XX%	X,XXX,XXX	X,XXX,XXX
SIZE RANGE (1000+)	XXX.XX%	XXX.XX%	XXX.XX%	XXX.XX%	X,XXX,XXX	X,XXX,XXX

RESPONSE RATES BY NAICS SECTOR	USABLE		TOTAL		CODE CHANGES:	NUMBER	PERCENTAGE
	UNITS	EMPLOYMENT	UNITS	EMPLOYMENT			
SECTOR 11	XXX.XX%	XXX.XX%	XXX.XX%	XXX.XX%	-----	-----	-----
SECTOR 21	XXX.XX%	XXX.XX%	XXX.XX%	XXX.XX%	NAICS CHANGE ONLY:	X,XXX,XXX	XXX.XX%
SECTOR 22	XXX.XX%	XXX.XX%	XXX.XX%	XXX.XX%	LOCATION CHANGE ONLY:	X,XXX,XXX	XXX.XX%
SECTOR 23	XXX.XX%	XXX.XX%	XXX.XX%	XXX.XX%	NAICS AND LOCATION:	X,XXX,XXX	XXX.XX%
SECTOR 31-33	XXX.XX%	XXX.XX%	XXX.XX%	XXX.XX%			
SECTOR 42	XXX.XX%	XXX.XX%	XXX.XX%	XXX.XX%	TOTAL CCS CODE CHANGES:	X,XXX,XXX	100.00%
SECTOR 44-45	XXX.XX%	XXX.XX%	XXX.XX%	XXX.XX%			
SECTOR 48-49	XXX.XX%	XXX.XX%	XXX.XX%	XXX.XX%			
SECTOR 51	XXX.XX%	XXX.XX%	XXX.XX%	XXX.XX%			
SECTOR 52	XXX.XX%	XXX.XX%	XXX.XX%	XXX.XX%			
SECTOR 53	XXX.XX%	XXX.XX%	XXX.XX%	XXX.XX%			
SECTOR 54	XXX.XX%	XXX.XX%	XXX.XX%	XXX.XX%			

EXHIBIT R – EXPO ARS Management Report (continued)

ARS PRINTED - NVS and NVM

DATE	NUMBER OF NVS) PRINTED	DATE	NUMBER OF NVM PRINTED
	0		0
	0		0
	0		0
	0		0
=====			
TOTALS	0		0
A mailing now would generate:			
		X,XXX,XXX NVS	
		X,XXX,XXX NVM	

EXHIBIT R – WIN ARS Management Report

DATE: MM/DD/YYYY
 TIME: 10:55:41
 DATE OF PREVIOUS SUMMARY: MM/DD/YYYY

BUREAU OF LABOR STATISTICS
 ANNUAL REFILEING CONTROL SYSTEM
 ARS MANAGEMENT REPORT FOR XXSTATE

PAGE: 1
 PRINTED FOR YR/QTR: YYYY/Q

 MAILING COUNTS ARE NOT AVAILABLE

RESPONSE STATUS	CODE	PERCENT OF TOTAL	SINGLES	SUBUNITS	TOTAL
-----	----	-----	-----	-----	-----
USEABLE RESPONSES --					
REVIEWED, NO CCS CHANGES	(41)	XXX.XX%	X,XXX,XXX	X,XXX,XXX	X,XXX,XXX
CODES CORRECT, EMPLOYER MISUNDERSTOOD					
THE INDUSTRY DESCRIPTION	(42)	XXX.XX%	X,XXX,XXX	X,XXX,XXX	X,XXX,XXX
CLEAN RECORD WITH CCS UPDATES	(46)	XXX.XX%	X,XXX,XXX	X,XXX,XXX	X,XXX,XXX
CODE CHANGE FROM OTHER SOURCES	(50)	XXX.XX%	X,XXX,XXX	X,XXX,XXX	X,XXX,XXX
		-----	-----	-----	-----
TOTAL USEABLE RESPONSES		XXX.XX%	X,XXX,XXX	X,XXX,XXX	X,XXX,XXX
OTHER RESPONSES --					
UPDATES, BUT HAS CCS I-ERROR	(30)	XXX.XX%	X,XXX,XXX	X,XXX,XXX	X,XXX,XXX
NOT REVIEWED - PENDING	(31)	XXX.XX%	X,XXX,XXX	X,XXX,XXX	X,XXX,XXX
POST OFFICE RETURN	(63)	XXX.XX%	X,XXX,XXX	X,XXX,XXX	X,XXX,XXX
OUT OF BUSINESS	(64)	XXX.XX%	X,XXX,XXX	X,XXX,XXX	X,XXX,XXX
REFUSAL	(65)	XXX.XX%	X,XXX,XXX	X,XXX,XXX	X,XXX,XXX
		-----	-----	-----	-----
TOTAL OTHER RESPONSES		XXX.XX%	X,XXX,XXX	X,XXX,XXX	X,XXX,XXX
		-----	-----	-----	-----
TOTAL ALL RESPONSES		XXX.XX%	X,XXX,XXX	X,XXX,XXX	X,XXX,XXX
NONRESPONDENTS					
MAILABLE, NOT YET MAILED,	(00, 11)	XXX.XX%	X,XXX,XXX	X,XXX,XXX	X,XXX,XXX
MAILED ONCE	(01)	XXX.XX%	X,XXX,XXX	X,XXX,XXX	X,XXX,XXX
MAILED TWICE	(02)	XXX.XX%	X,XXX,XXX	X,XXX,XXX	X,XXX,XXX
MAILED THREE TIMES	(03)	XXX.XX%	X,XXX,XXX	X,XXX,XXX	X,XXX,XXX
MAILED FOUR TIMES	(04)	XXX.XX%	X,XXX,XXX	X,XXX,XXX	X,XXX,XXX
UNMAILABLE RECORDS	(12, 99)	XXX.XX%	X,XXX,XXX	X,XXX,XXX	X,XXX,XXX
		-----	-----	-----	-----
TOTAL NONRESPONDENTS - NOT YET MAILED, MAILED, UNMAILABLE, ETC. (EXCLUDING MASTER RECORDS)		XXX.XX%	X,XXX,XXX	X,XXX,XXX	X,XXX,XXX
		-----	-----	-----	-----
TOTAL NUMBER OF CONTROL FILE RECORDS (EXCLUDING MASTER RECORDS)		100.00%	X,XXX,XXX	X,XXX,XXX	X,XXX,XXX

EXHIBIT R – WIN ARS Management Report (continued)

USEABLE RESPONSE RATE:	UNITS	EMPLOYMENT	TOTAL RESPONSE RATE:	UNITS	EMPLOYMENT
ALL	XXX.XX%	XXX.XX%	ALL	XXX.XX%	XXX.XX%
SINGLES	XXX.XX%	XXX.XX%	SINGLES	XXX.XX%	XXX.XX%
SUBUNITS	XXX.XX%	XXX.XX%	SUBUNITS	XXX.XX%	XXX.XX%

DATE: MM/DD/YYYY
TIME: HH:MM:SS

BUREAU OF LABOR STATISTICS
ANNUAL REFILE CONTROL SYSTEM
ARS MANAGEMENT REPORT FOR XXSTATE

PAGE: 2
PRINTED FOR YR/QTR: YYYY/Q

RESPONSE RATES BY SIZE RANGE:	TOTAL		USEABLE		TOTAL RECORDS	
	UNITS	EMPLOYMENT	UNITS	EMPLOYMENT	UNITS	EMPLOYMENT
SIZE RANGE 0 (0)	XXX.XX%	XXX.XX%	XXX.XX%	XXX.XX%	X,XXX,XXX	X,XXX,XXX
SIZE RANGE 1 (1-9)	XXX.XX%	XXX.XX%	XXX.XX%	XXX.XX%	X,XXX,XXX	X,XXX,XXX
SIZE RANGE 2 (10-49)	XXX.XX%	XXX.XX%	XXX.XX%	XXX.XX%	X,XXX,XXX	X,XXX,XXX
SIZE RANGE 3 (50-99)	XXX.XX%	XXX.XX%	XXX.XX%	XXX.XX%	X,XXX,XXX	X,XXX,XXX
SIZE RANGE 4 (100-249)	XXX.XX%	XXX.XX%	XXX.XX%	XXX.XX%	X,XXX,XXX	X,XXX,XXX
SIZE RANGE 5 (250-999)	XXX.XX%	XXX.XX%	XXX.XX%	XXX.XX%	X,XXX,XXX	X,XXX,XXX
SIZE RANGE 6 (1000+)	XXX.XX%	XXX.XX%	XXX.XX%	XXX.XX%	X,XXX,XXX	X,XXX,XXX

RESPONSE RATES BY NAICS SECTOR	TOTAL		USABLE		CODE CHANGES:	NUMBER	PERCENTAGE
	UNITS	EMPLOYMENT	UNITS	EMPLOYMENT			
SECTOR 11	XXX.XX%	XXX.XX%	XXX.XX%	XXX.XX%	NAICS CHANGE ONLY:	X,XXX,XXX	XXX.XX%
SECTOR 21	XXX.XX%	XXX.XX%	XXX.XX%	XXX.XX%	LOCATION CHANGE ONLY:	X,XXX,XXX	XXX.XX%
SECTOR 22	XXX.XX%	XXX.XX%	XXX.XX%	XXX.XX%	NAICS AND LOCATION:	X,XXX,XXX	XXX.XX%
SECTOR 23	XXX.XX%	XXX.XX%	XXX.XX%	XXX.XX%			
SECTOR 31-33	XXX.XX%	XXX.XX%	XXX.XX%	XXX.XX%			
SECTOR 42	XXX.XX%	XXX.XX%	XXX.XX%	XXX.XX%	TOTAL CCS CODE CHANGES:	X,XXX,XXX	100.00%
SECTOR 44-45	XXX.XX%	XXX.XX%	XXX.XX%	XXX.XX%			
SECTOR 48-49	XXX.XX%	XXX.XX%	XXX.XX%	XXX.XX%			
SECTOR 51	XXX.XX%	XXX.XX%	XXX.XX%	XXX.XX%			
SECTOR 52	XXX.XX%	XXX.XX%	XXX.XX%	XXX.XX%			
SECTOR 53	XXX.XX%	XXX.XX%	XXX.XX%	XXX.XX%			
SECTOR 54	XXX.XX%	XXX.XX%	XXX.XX%	XXX.XX%			
SECTOR 55	XXX.XX%	XXX.XX%	XXX.XX%	XXX.XX%			
SECTOR 56	XXX.XX%	XXX.XX%	XXX.XX%	XXX.XX%			

EXHIBIT R – WIN ARS Management Report (continued)

SECTOR 61	XXX.XX%	XXX.XX%	XXX.XX%	XXX.XX%
SECTOR 62	XXX.XX%	XXX.XX%	XXX.XX%	XXX.XX%
SECTOR 71	XXX.XX%	XXX.XX%	XXX.XX%	XXX.XX%
SECTOR 72	XXX.XX%	XXX.XX%	XXX.XX%	XXX.XX%
SECTOR 81	XXX.XX%	XXX.XX%	XXX.XX%	XXX.XX%
SECTOR 92	XXX.XX%	XXX.XX%	XXX.XX%	XXX.XX%
SECTOR 99	XXX.XX%	XXX.XX%	XXX.XX%	XXX.XX%

USEABLE RESPONSE RATE:

NUMERATOR -- RESPONSE CODES 32 + 41 + 42 + 46 + 50

DENOMINATOR -- RESPONSE CODES 00 + 03 + 04 + 11 + 30 + 31 + 32 + 41 + 42 + 46 + 50 + 65

TOTAL RESPONSE RATE:

NUMERATOR - RESPONSE CODES 30 + 31 + 32 + 41 + 42 + 46 + 50 + 63 + 64 + 65

DENOMINATOR - RESPONSE CODES 00 + 03 + 04 + 11 + 30 + 31 + 32 + 41 + 42 + 46 + 50 + 63 + 64 + 65

FOR THE USEABLE RESPONSE RATE, THE NUMERATOR EXCLUDES LATE RESPONSES TO THE CURRENT REFILEING.
THE DENOMINATOR EXCLUDES NONRESPONDENTS CARRIED OVER FROM LAST YEAR, UNLESS THEY HAVE A USEABLE RESPONSE.

DATE: MM/DD/YYYY
TIME: HH:MM:SS

BUREAU OF LABOR STATISTICS
ANNUAL REFILEING CONTROL SYSTEM
ARS MANAGEMENT REPORT FOR XXSTATE

PAGE: 3
PRINTED FOR YR/QTR: YYYY/Q

ARS PRINTED

DATE	NUMBER OF NVS PRINTED	DATE	DATE	NUMBER OF NVM PRINTED	
Totals:	0			0	0 Total Responses: XXX,XXX

EXHIBIT R – WIN ARS Management Report (continued)

```

size50      XXXXXX  XXXXXX  XXXXXX  XXXXXX  XXXXXX  XXXXXX  XXXXXX
size57      XXXXXX  XXXXXX  XXXXXX  XXXXXX  XXXXXX  XXXXXX  XXXXXX
size63      XXXXXX  XXXXXX  XXXXXX  XXXXXX  XXXXXX  XXXXXX  XXXXXX
size64      XXXXXX  XXXXXX  XXXXXX  XXXXXX  XXXXXX  XXXXXX  XXXXXX
size65      XXXXXX  XXXXXX  XXXXXX  XXXXXX  XXXXXX  XXXXXX  XXXXXX
size76      XXXXXX  XXXXXX  XXXXXX  XXXXXX  XXXXXX  XXXXXX  XXXXXX
size77      XXXXXX  XXXXXX  XXXXXX  XXXXXX  XXXXXX  XXXXXX  XXXXXX
size98      XXXXXX  XXXXXX  XXXXXX  XXXXXX  XXXXXX  XXXXXX  XXXXXX
size99      XXXXXX  XXXXXX  XXXXXX  XXXXXX  XXXXXX  XXXXXX  XXXXXX
    
```

```

/*****
/* month 3 employment totals by size category, and response code */
/*****
/* 1 = 0 emp;      2 = 1-9 emp;      3 = 10-49 emp; 4 = 50-99 emp */
/* 5 = 100-249 emp; 6 = 250-999 emp; 7 = 1000+ emp */
/*****
    
```

Array Name	1	2	3	4	5	6	7
emp-00	XXXXXX	XXXXXX	XXXXXX	XXXXXX	XXXXXX	XXXXXX	XXXXXX
emp-01	XXXXXX	XXXXXX	XXXXXX	XXXXXX	XXXXXX	XXXXXX	XXXXXX
emp-02	XXXXXX	XXXXXX	XXXXXX	XXXXXX	XXXXXX	XXXXXX	XXXXXX
emp-03	XXXXXX	XXXXXX	XXXXXX	XXXXXX	XXXXXX	XXXXXX	XXXXXX
emp-04	XXXXXX	XXXXXX	XXXXXX	XXXXXX	XXXXXX	XXXXXX	XXXXXX
emp-11	XXXXXX	XXXXXX	XXXXXX	XXXXXX	XXXXXX	XXXXXX	XXXXXX
emp-12	XXXXXX	XXXXXX	XXXXXX	XXXXXX	XXXXXX	XXXXXX	XXXXXX
emp-30	XXXXXX	XXXXXX	XXXXXX	XXXXXX	XXXXXX	XXXXXX	XXXXXX
emp-31	XXXXXX	XXXXXX	XXXXXX	XXXXXX	XXXXXX	XXXXXX	XXXXXX
emp-32	XXXXXX	XXXXXX	XXXXXX	XXXXXX	XXXXXX	XXXXXX	XXXXXX
emp-41	XXXXXX	XXXXXX	XXXXXX	XXXXXX	XXXXXX	XXXXXX	XXXXXX
emp-42	XXXXXX	XXXXXX	XXXXXX	XXXXXX	XXXXXX	XXXXXX	XXXXXX
emp-43	XXXXXX	XXXXXX	XXXXXX	XXXXXX	XXXXXX	XXXXXX	XXXXXX
emp-46	XXXXXX	XXXXXX	XXXXXX	XXXXXX	XXXXXX	XXXXXX	XXXXXX
emp-50	XXXXXX	XXXXXX	XXXXXX	XXXXXX	XXXXXX	XXXXXX	XXXXXX
emp-57	XXXXXX	XXXXXX	XXXXXX	XXXXXX	XXXXXX	XXXXXX	XXXXXX
emp-63	XXXXXX	XXXXXX	XXXXXX	XXXXXX	XXXXXX	XXXXXX	XXXXXX
emp-64	XXXXXX	XXXXXX	XXXXXX	XXXXXX	XXXXXX	XXXXXX	XXXXXX
emp-65	XXXXXX	XXXXXX	XXXXXX	XXXXXX	XXXXXX	XXXXXX	XXXXXX
emp-76	XXXXXX	XXXXXX	XXXXXX	XXXXXX	XXXXXX	XXXXXX	XXXXXX
emp-77	XXXXXX	XXXXXX	XXXXXX	XXXXXX	XXXXXX	XXXXXX	XXXXXX
emp-98	XXXXXX	XXXXXX	XXXXXX	XXXXXX	XXXXXX	XXXXXX	XXXXXX
emp-99	XXXXXX	XXXXXX	XXXXXX	XXXXXX	XXXXXX	XXXXXX	XXXXXX

Response Code 20 (Wave 2 records): 0

Appendix S – BLS Naming Convention

This appendix details the recommended standard naming convention for production email shared between national office, BLS regional offices, and states. This serves to expedite operations by helping to clarify details in the subject line related to the production email. These standards should be followed by state and BLS production staff when composing email subject lines. This does not affect the naming of files.

STATE SUBMITTALS:

YYQ.ST_Submittal

YYQ: two-digit year followed by one-digit quarter.

Example: 2019 quarter 1 is 191.

ST: two-digit state abbreviation

Submittal: identifies what is currently being delivered or discussed.

Some example values include: Macro, Primary, Secondary, Subset, Subset2.

Examples:

2019 third quarter first macro file from TX:	193.TX_Macro
2019 third quarter primary file from TX:	193.TX_Primary
2019 third quarter primary file from TX:	193.TX_Secondary
2019 third quarter subset file from TX:	193.TX_Subset
2019 third quarter second subset file from TX:	193.TX_Subset2

STATE RESPONSE TO BLS REVIEW QUESTIONS (NOQs/ROQs):

Append **_RESP_S** to the end of NOQ/ROQ subject lines when responding back to BLS.

Example:

CDA Branch sends INOQ set #2 to California during 2025 third quarter review.

CDA question subject line is: 253_CA_INOQ_2_CDA

CA response subject line is: 253_CA_INOQ_2_CDA_RESP_S

OTHER MESSAGES RELATING TO PRODUCTION

Begin messages with **YYQ.ST_** followed by subject line text chosen by the author.

Example: New York concern re a PEO during 2018 fourth quarter production.

184.NY_A Big PEO stopped reporting by client

Issues that affect more than one state should use **US** instead of a state abbreviation.

Appendix T – Useful Links and References

This appendix contains links to Internet websites, Intranet sites and documents that state and BLS staff may find useful. The title of each is followed by the URL (or the path) and a brief explanation of what that site or document contains. Clicking on the URL or path will take you directly to the site. Many of these sites contain sub menus or links that might also prove helpful.

American Statistical Association (ASA)

<http://www.amstat.org/>

This is the official website of the American Statistical Association, which works to promote statistical practice, applications, and research; publish statistical journals; improve statistical education; and advance the statistics profession. The ASA serves its members as well as the broader scientific community and the public at large. Several links and responses to FAQs are provided.

Association for University Business and Economic Research (AUBER)

<http://www.auber.org/>

AUBER is a professional organization dedicated to continually improving the quality, effectiveness, and application of research in business, economics, and public policy. Every state has its own experts and specialized data collections; one fast way to find them is *through AUBER's state-by-state directory of resources*.

Bureau of Economic Analysis (BEA)

<http://www.bea.gov/>

This site is the home page of the Bureau of Economic Analysis, an agency of the U.S. Department of Commerce that prepares measurements and estimates of key aspects of the U.S. economy including the gross domestic product (GDP.) BEA is an important customer of QCEW.

Business Employment Dynamics (BED)

<http://www.bls.gov/bdm>.

This web page is dedicated to providing information about Business Employment Dynamics data. BED data are a quarterly series of gross job gains and gross job losses statistics for the entire economy. These data track changes in employment at the establishment level, and thus provide a picture of the dynamics underlying aggregate net employment growth statistics. The microdata used to construct the gross job gains and gross job losses statistics are from the QCEW program.

Bureau of the Census

<http://www.census.gov>

This site is the home page of the Census Bureau, an agency of the U.S. Department of Commerce that conducts the decennial census of the United States and gathers data on various aspects of the population. It is a source of quality data about the nation's people and economy.

Bureau of Labor Statistics (BLS)

<http://www.bls.gov>

This site is the home page of the Bureau of Labor Statistics. It contains a wealth of BLS statistics, reports, publications, and links to other useful sites. The Bureau of Labor Statistics of the U.S. Department of Labor is the principal Federal agency responsible for measuring labor market activity, working conditions, and price changes in the economy. Its mission is to collect, analyze, and disseminate essential economic information to support public and private decision-making. As an independent statistical agency, BLS serves its diverse user communities by providing products and services that are objective, timely, accurate, and relevant.

BLS Handbook of Methods

<https://www.bls.gov/opub/hom/home.htm> This site presents detailed explanations on how BLS obtains and prepares the economic data it publishes. BLS statistics are used for many purposes, and sometimes data well suited to one purpose may have limitations for another. This publication aims to provide users of BLS data with the most current information necessary to evaluate the suitability of the statistics for their needs.

Cheat Sheet (please see [Valid Values](#))

City/County Cross Reference

<http://www.citycountyxref.info/#>

This site provides city and county cross references by state. Select a state to enter a city and view the county the city is located in. Another site states have reported is helpful for verifying county assignments is <http://www.mob-rule.com> Enter (or copy and paste) an address to identify in what county the address is located. Please see [Zip Code](#) related entries at the end of this appendix for more useful links.

Comparison of State Unemployment Insurance Laws

<https://workforcesecurity.doleta.gov/unemploy/Statelaws.asp>

The Comparison of State Unemployment Insurance Laws provides state-by-state information on workers covered, benefit eligibility, methods of financing and other areas of interest in the UI program. It also includes information on the temporary disability programs operated in six states. The Comparison is published annually.

Corporate Information

<http://www.corporateinformation.com>

This site provides links to global company information, such as company profiles, research reports, and industry analyses. It also includes links by state to many providers of Web-based company information (for example, business directories) often including addresses, phone numbers, and website addresses. It focuses on publically traded companies.

Department of Labor (DOL)

<http://www.dol.gov/>

This is the home page of the U.S. Department of Labor, an agency whose mission is “To foster, promote, and develop the welfare of the wage earners, job seekers, and retirees of the United States; improve working conditions; advance opportunities for profitable employment; and

assure work-related benefits and rights.” It includes, among numerous other topics, statistics and data published by several DOL agencies. The publication schedule is available here <https://www.dol.gov/general/aboutdol/content>.

Econ Data.Net

<http://www.econdata.net>

This site is a guide to regional economic data on the web. It is designed to help data users quickly gain access to relevant state and sub-state socioeconomic data. It includes various links for employment data, industry sectors, and firm listings, and provides access to a user's guide for understanding regional socioeconomic data.

Economagic

<http://www.economagic.com/>

This site gives you easy access to more than 100,000 data series including state, metro and county employment data compiled by federal statistical agencies. It has some international data, as well. The site will create spreadsheet files of data on-line as well as graphing data in your internet browser. Registered users can generate forecasts from historical data.

EXPO

<http://199.221.111.170/program/ES202/EXPOWIN.htm>

This is the home page for the Exportable QCEW System (EXPO), the standard QCEW state processing system developed by the state of Utah and used by the majority of states. This site provides program updates, access to user and system documentation, and details about DMA. Contact details: The EXPO hotline is 877-614-3387 or you can email EXPOHELP@BLS.gov. This email group contains members BLS national office staff, as well as Utah state staff who work on the EXPO system. *Please be sure to –cc your regional office if you are a state staff member emailing EXPOHELP.

Electronic Data Interchange Center (EDIC)

<https://199.221.111.47/>

This is the homepage for the EDIC, a BLS Center located in Chicago that is responsible for collecting, editing, and correcting Multiple Worksite Reports (MWR) and Current Employment Statistics (CES) data for multi-state employers and providing this data to the states. Contact details: EDIBLSstaff@BLS.GOV is the general email group for the EDIC.

Electronic Data Reporting

<https://www.bls.gov/cew/cewmwr02.htm>

Copies of the Electronic Data Reporting Booklet are provided to employers who are considering the central reporting of their MWR data to the EDI Center in Chicago. It provides the standard flat file formats for reporting the MWR data for the QCEW program as well as CES data. The same information is also available on the Multiple Worksite Report website.

Federal Committee on Statistical Methodology (FCSM)

<https://fcsm.sites.usa.gov/>

This is the website of FCSM, an interagency committee sponsored by the U.S. Office of Management and Budget to improve the quality of federal statistics, as well as the efficiency and effectiveness of statistical practice among Federal agencies.

Federal Statistics (FedStats)

<https://fedstats.sites.usa.gov/>

This site contains links to more than 100 federal government agencies producing and disseminating federal statistics of interest to the public. It is maintained by the Federal Interagency Council on Statistical Policy.

Federal Information Processing Standards (FIPS)

<https://www.census.gov/geo/reference/codes/cou.html>

This site provides links to the complete and current FIPS county codes for all States and territories. FIPS codes were developed by the National Institute of Standards and Technology (NIST) but later discontinued by NIST; the Census Bureau continues to maintain and issue codes for geographic entities.

Information Technology Support Center (ITSC)

<http://www.itsc.state.md.us/Pages/default.aspx>

This is the home page of the ITSC, a collaboration of State Employment Security Agencies, the U.S. Department of Labor, and private sector partners. The ITSC is dedicated to advancing the appropriate application of information technology, which states may adopt, to provide more accurate, efficient, cost effective, and timely service for unemployed insurance customers. It contains a map that shows which states are undergoing UI modernization efforts.

<http://www.itsc.state.md.us/Pages/UI-IT-Mod.aspx>

Melissa Data

<http://melissadata.com/Lookups/index.htm>

This website provides free lookups online for zip codes, NAICS codes, counties, and other useful information.

Merriam-Webster's Dictionary

<https://www.merriam-webster.com/>

This is an obvious, but useful, site which may help make sense of a respondent's explanation of their product or services. It helps to classify a widget company if you know what it is.

Mexico National Institute of Statistics, Geography and Informatics (INEGI in Spanish)

<http://en.www.inegi.org.mx/>

English version home page of the Mexican government agency that provides statistical, geographic, demographic, and economic information on the country.

Monthly Labor Review Online

<http://www.bls.gov/opub/mlr/mlrhome.htm>

This site is based on the print version of the Monthly Labor Review (MLR). The MLR is the principal journal of fact, analysis, and research from the Bureau of Labor Statistics. The

Economics Daily section, which is updated daily to highlight one or two particular points, can also be reached from this MLR page or directly at <https://www.bls.gov/opub/ted/home.htm>

Multiple Worksite Report (MWR)

<http://stats.bls.gov/cew/cewmwr00.htm>

This site describes the MWR and provides related information, including contact information by State, FAQs, and information on reporting electronically through the EDI Center.

National Technical Information Service

<https://www.ntis.gov/>

Provide innovative data services to federal agencies, through joint venture partnerships with the private sector, to advance federal data priorities, promote economic growth, and enable operational excellence.

North American Industry Classification System (NAICS)

<https://www.bls.gov/bls/naics.htm>

The general BLS NAICS page introduces the classification system.

https://www.bls.gov/cew/bls_naics/v1/bls_naics_app.htm

This BLS WebNAICS application provides access to the North American Industry Classification System (NAICS) as implemented at BLS. It is intended for use by BLS data users and by BLS and state staff working on statistical data development and production. It is possible to toggle between the 2012 and 2017 versions.

<http://www.census.gov/epcd/www/naics.html>

This site, maintained by the U.S. Census Bureau, includes background information, a 2017 NAICS manual, and related information on NAICS. Please note, BLS-only NAICS codes are not listed in the NAICS search feature.

Policy Council (QCEW)

<http://199.221.111.170/Programs/BLOC/qcew/qcewPC.html>

This section of StateWeb contains the QCEW policy council charter, meeting minutes, membership details, as well as links to the BLOC and other program policy council pages

Quarterly Census of Employment and Wages (QCEW)

<http://www.bls.gov/cew/>

The Quarterly Census of Employment and Wages (QCEW) program publishes a quarterly count of employment and wages reported by employers covering more than 95 percent of U.S. jobs, available at the county, MSA, state and national levels by industry. This site gives an overview of the QCEW Program, provides QCEW data, answers Frequently Asked Questions (FAQs), and gives contact information.

Quarterly Census of Employment and Wages (QCEW) Management Information

<http://199.221.111.170/Programs/QCEW/qcewprograminfo.html>

This section of StateWeb provides useful charts, tables, and other data on state performance indicators.

Social Security's Online Guide to Wage Reporting for Employers

<https://www.ssa.gov/employer/>

This site provides information, requirements, services, and assistance for employer wage reporting.

State Help

StateHelp provides IT- related support to state users for resetting passwords, unlocking accounts, and adding EXPO, EUSWeb, and email accounts.

Contact information:

<http://199.221.111.170/statehelpdesk/default.aspx>

STATEHELP Network Assistance 202-691-5950

StateWeb

<http://199.221.111.170/index.html>

This site provides access to the Fed/State numbered memoranda for QCEW, CES, and other Fed/State programs. It also gives access to meeting and training schedules, policy council minutes, regional office telephone numbers, and general program information. The direct link to the QCEW section is <http://199.221.111.170/program/ES202/QCEWmain.htm>

Statistics Canada

<http://www.statcan.gc.ca/eng/start>

This is the English home page of Canada's national statistical agency, which provides economic, geographic, demographic, social, socio-economic, and socio-political information about the nation.

SuperPages

<http://www.superpages.com/>

This search site allows the user to locate businesses by category, business name, and city, State. It gives business information, including phone, fax numbers, addresses and URLs and includes a nationwide yellow pages and reverse phone number lookup facility. This site may be useful for identifying, researching, or contacting employers.

Unemployment Insurance Program Letters (UIPL)

<https://wdr.doleta.gov/directives/>

This site provides access to UI Program Letters (UIPL). UIPL give coverage rulings, policy, and determinations made by the Director of the Unemployment Insurance Service of the Employment and Training Administration. There are also links to Training & Employment Guidance Letters (TEGL) and Training & Employment Notices (TEN).

Valid Values (aka Cheat Sheet)

<http://199.221.111.170/Programs/QCEW/index.html>

This document provides a summary of due dates, code definitions, contact information, and a variety of other useful documentation.

WebNAICS (Please also see [North American Industry Classification System](#))

https://www.bls.gov/cew/bls_naics/v1/bls_naics_app.htm

WIN

<http://www.state.me.us/labor/lmis/win-202/>

This is the home page for the WIN –202 System, a standard QCEW State processing system developed by the State of Maine. This site provides system documentation, training info, prefabricated queries, new release info, a facility for submitting questions or comments, contact information, and a list of FAQs.

Contact details:

PHONE: 207-621-5186

<http://www.maine.gov/labor/lmis/win-202/>

win-202@Maine.gov

*Please be sure to –cc your regional office if you are a state staff member emailing win-202.

Workforce Information Advisory Council (WIAC)

<https://www.doleta.gov/wioa/wiac/> The Workforce Information Advisory Council (WIAC) is a Federal Advisory Committee of workforce and labor market information experts representing a broad range of national, state, and local data and information users and producers. The purpose of the WIAC is to provide recommendations to the Secretary of Labor, working jointly through the Assistant Secretary for Employment and Training and the Commissioner of Labor Statistics

ZipInfo

<http://www.zipinfo.com/search/zipcode.htm>

For any valid zip code, this site will find the city and state plus the county name and FIPS code, time zone, MSA/PMSA, area code, latitude and longitude, and population. Please note that this site uses the zip centroid method of geocoding, which is considered less desirable than finding the latitude and longitude at the street address level.

Zip+4 Code Lookup

http://www.usps.gov/ncsc/lookups/lookup_zip+4.html

This site, developed by the U.S. Postal Service National Customer Support Center, can be used to find Zip codes. Enter the delivery address onto the form, and it returns the Zip code and the standardized address.

Appendix U – Publication Macro Aggregation Levels

QCEW micro data are aggregated to macro levels for publication purposes. This appendix is included for reference purposes to show the macro levels at which data are produced. The code associated with each level is an internal code used in the systems within the national office. Eventual publication drives many of the questions that are asked during the BLS review phase of QCEW operations.

Aggregation Level	Code
National.....	10
All MSAs	91
All CSAs	92
All non-MSA counties	93
National x Own2-5 (UI-covered).....	94
National x Own1-3.....	95
State x Own1-3	96
National x Own.....	11
National x Own x Domain ^a	12
National x Own x Supersector ^b	13
National x Own x Sector.....	14
National x Own x 3-digit NAICS	15
National x Own x 4-digit NAICS	16
National x Own x 5-digit NAICS	17
National x Own x 6-digit NAICS	18
National x Own5 x Size	21
National x Own5 x Size x Domain ^a	22
National x Own5 x Size x Supersector ^b	23
National x Own5 x Size x Sector.....	24
National x Own5 x Size x 3-digit NAICS	25
National x Own5 x Size x 4-digit NAICS	26
National x Own5 x Size x 5-digit NAICS	27
National x Own5 x Size x 6-digit NAICS	28
CSA.....	30
MSA.....	40
MSA x Own.....	41
MSA x Own5 x Domain ^a	42
MSA x Own5 x Supersector ^b	43
MSA x Own5 x Sector.....	44
MSA x Own5 x 3-digit NAICS	45
MSA x Own5 x 4-digit NAICS	46
MSA x Own5 x 5-digit NAICS	47
MSA x Own5 x 6-digit NAICS	48
State.....	50
State x Own.....	51
State x Own x Domain ^a	52
State x Own x Supersector ^b	53
State x Own x Sector.....	54
State x Own x 3-digit NAICS	55
State x Own x 4-digit NAICS	56
State x Own x 5-digit NAICS	57
State x Own x 6-digit NAICS	58

State x Own5 x Size61
 State x Own5 x Size x Domain^a62
 State x Own5 x Size x Supersector^b63
 State x Own5 x Size x Sector.....64

County.....70
 County x Own71
 County x Own x Domain^a.....72
 County x Own x Supersector^b73
 County x Own x Sector.....74
 County x Own x 3-digit NAICS75
 County x Own x 4-digit NAICS76
 County x Own x 5-digit NAICS77
 County x Own x 6-digit NAICS78

MicroSA.....80

^a Domain refers to the division of all economic activity into two domains, goods-producing and service-producing.

^b Supersector refers to the 11 alternate aggregation sectors defined by the ECPC plus the additional sector for unclassified.

Appendix V – Geocode File Format

The national office sends to the states geocoded Load files and Reject files containing records that were unable to be geocoded. The Reject file contains non geocodable records with employment of 100 or more. The file format for both files are below:

Geocode Load Format			
Positions	Load/No Load	Data Element	Length
1-2	No	State FIPS Code	2
3-6	No	Load Year	4
7-7	No	Load Quarter	1
8-17	No	UI Account Number	10
18-22	No	Reporting Unit Number	5
23-57	No	Trade Name	35
58-92	No	Legal Name	35
93-100	No	PLA Date Changed	8
101-104	No	ARS Refile Year	4
105-105	No	MEEI Code	1
106-111	No	NAICS Code	6
112-112	No	Ownership Code	1
113-115	No	County Code	3
116-121	No	Month Three Employment	6
122-156	Not at this time	Standardized or from Alternate Source PLA Street Address--Line 1	35
157-191	Not at this time	Standardized or from Alternate Source PLA Street Address--Line 2	35
192-221	Not at this time	Standardized or from Alternate Source PLA City	30
222-223	Not at this time	Standardized or from Alternate Source PLA State	2
224-228	Not at this time	Standardized or from Alternate Source PLA ZIP Code	5
229-232	Not at this time	Standardized or from Alternate Source PLA ZIP Extension	4
233-235	Future Use	Filler	3
236-246	Yes	Longitude	11
247-255	Yes	Latitude	9
256-259	Yes	Match Code	4
260-262	Yes	Location Code	3
263-267	Yes	Place Code	5
268-269	Yes	Class Code	2
270-284	Yes, if available	Census ID (comprised of 2-position State code, 3-position County code, 6-position Tract code, 1-position block group, 2-position block code, and 1-position block code letter)	15
285-288	Future Use	Filler	4
289-289	Future Use	Address Source Code	1
290-349	Future Use	E-mail Address from Alternate Source	60

Geocode Load Format			
Positions	Load/No Load	Data Element	Length
350-355	Future Use	NAICS from Alternate Source	6
356-370	Future Use	Phone from Alternate Source	15
371-380	Future Use	Fax from Alternate Source	10
381-415	Future Use	MOA Street Address--Line 1 from Alternate Source	35
416-450	Future Use	MOA Street Address--Line 2 from Alternate Source	35
451-480	Future Use	MOA City from Alternate Source	30
481-482	Future Use	MOA State from Alternate Source	2
483-487	Future Use	MOA ZIP Code from Alternate Source	5
488-491	Future Use	MOA ZIP Extension from Alternate Source	4

Geocode Reject File Format		
Positions	Data Element	Length
1-2	State FIPS Code	2
3-6	Reference Year	4
7-7	Reference Quarter	1
8-17	UI Account Number	10
18-22	Reporting Unit Number	5
23-23	MEEI Code	1
24-29	NAICS Code	6
30-30	Ownership Code	1
31-33	County Code	3
34-39	Month Three Employment	6
40-74	Legal Name	35
75-109	Trade Name	35
110-144	Input PLA Street Address--Line 1	35
145-179	Input PLA Street Address--Line 2	35
180-209	Input PLA City	30
210-211	Input PLA State	2
212-216	Input PLA ZIP Code	5
217-220	Input PLA ZIP Extension	4
221-221	MOA Address Type Code	1
222-222	UI Address Type Code	1
223-226	Match Code	4
227-229	Location Code	3
230-289	Website URL	60
290-295	NAICS from Alternate Source	6
296-305	Telephone Number	10
306-310	Telephone Number Extension	5

Glossary

The following defined terms are used in the QCEW program, and most of them appear in this manual.

Advance Release

Providing a BLS news or data release (or any part or derivative of a release) to a person or organization outside the BLS prior to its official date and time of public release.

Agent

An individual who meets the definition of agent as set forth by CIPSEA and who has been designated by the BLS to perform exclusively statistical activities through an Agent Agreement. The 53 State Workforce Agency LMI staffs that work on the BLS Federal/State Cooperative Programs, such as the QCEW program, are designated as agents of the BLS.

The QCEW program also collects identifiers on businesses that either only file or fully prepare and report QCR data and UI taxes to the states for specific employers. These identifiers are collected in the form of an Agent Code. Additional information on Agent Codes can be found in appendix B, section A of this manual.

Annual Refiling Survey (ARS)

A survey conducted by the QCEW program to verify and update the industry, geographic area, addresses, and codes of business establishments covered by state unemployment insurance programs

ARS Web

Internet based collection of Annual Refiling Survey.

Authorized Persons

Officers, employees, and agents of the BLS who are responsible for collecting, processing, or using confidential data in furtherance of statistical purposes or for the other stated purposes for which the data were collected. Authorized persons are authorized access to only those confidential data that are integral to the program or project on which they work, and only to the extent required to perform their duties.

Authorization Statement

The statement included on BLS forms and Cover Letters that cites the United States Code that authorizes the BLS survey and, if applicable, the state law that mandates it.

Average Monthly Employment (AME)

Computed as the average of the three monthly employment figures in a given calendar quarter.

$$AME = \frac{(M1+M2+M3)}{3}$$

where M1 = Month One Employment
M2 = Month Two Employment

M3 = Month Three Employment

Average Quarterly Wages (AQW)

Computed as total quarterly wages (TQW) divided by average monthly employment (AME).

$$AQW = \frac{TQW}{AME}$$

Average Weekly Wages (AWW)

Computed as average quarterly wages divided by 13.

$$AWW = \frac{AQW}{13}$$

Benchmarking

A point of reference (either an estimate or a count) from which measurements can be made or upon which adjustments to estimates are based. The QCEW data serves as a benchmark input for many BLS programs.

Birth

Those units that are new establishments that are not linked to any pre-existing establishment(s) in the state.

Breakout

The disaggregation to more detailed sub-units of a reporting unit.

Bureau of Economic Analysis (BEA)

A Federal statistical agency that is part of the U.S. Department of Commerce. BEA uses data from the QCEW program in the estimation of Gross Domestic Product (GDP) and personal income statistics.

Bureau of Labor Statistics (BLS)

A Federal statistical agency that is part of the U.S. Department of Labor. BLS functions as the principal data-gathering agency of the Federal government in the field of labor economics. The BLS collects, processes, analyzes, and disseminates data relating to employment, unemployment, the labor force, productivity, prices, family expenditures, wages, industrial relations, and occupational safety and health.

Business Cycle

A periodically repeated sequence of fluctuations in the aggregate economy of an area, or the nation as a whole, varying in duration, but consisting of: (a) upturn, including recovery and prosperity; (b) cyclical peak; (c) downturn, including recession; and (d) cyclical trough.

Business Employment Dynamics (BED)

Quarterly data produced by the QCEW program that shows the number of job gains from opening and expanding establishments, the number of job losses from closing and contracting establishments, and the net gain or loss. BED statistics show the dynamic labor market changes that underlie the net employment change statistic.

Census

A complete count (i.e., not a sample) of a specified population or some other measurable characteristic in a given area (housing, industry, etc.).

Census Block

A subdivision of a census tract. A block is the smallest geographic unit for which the Census Bureau tabulates data.

Census Tract

A small, relatively permanent statistical subdivision of a county delineated by a local committee of census data users for the purpose of presenting data.

CARS

Central Annual Refiling Survey (CARS). Contractor utilized for central sending and receiving of the ARS forms.

Central Review

As a part of the Annual Refiling Survey (ARS) BLS staff review the industry classification of selected large multi-firms based on size class, employment and NAICS homogeneity. The purpose of the central review is to increase coding consistency across states while reducing both respondent burden and postage costs.

Centroid

The calculated center of a zip code. The centroid is part of the methodology sometimes used to assign latitude and longitude to addresses based on zip code.

Code Change Supplement (CCS)

A computer file generated from the BLS or state system. The Code Change Supplement documents all non-economic changes to industry, area, and ownership classification codes that will be made effective with the first quarter data. It is used to measure the impact of classification changes on QCEW macro data tabulations.

Collapse

The consolidation of detailed sub-units to a single reporting unit.

Combined Statistical Area (CSA)

Consists of two or more adjacent metropolitan and micropolitan statistical areas that have substantial employment interchange. The metropolitan and micropolitan statistical areas that combine to create a CSA retain separate identities within the larger CSA.

Comment Codes

Standardized numeric codes used by the QCEW program to explain fluctuations and unusual economic and noneconomic occurrences in the data. These codes are assigned to micro data records.

CIPSEA

Confidential Information Protection and Statistical Efficiency Act of 2002 (CIPSEA), Title 5 of Public Law 107 347, establishes statutory provisions protecting the confidentiality of data collected by Federal Executive Branch agencies for exclusively statistical purposes under a pledge of confidentiality.

Consumer Price Index (CPI)

A Bureau of Labor Statistics program that measures the average change in the prices of a fixed set of goods and services purchased by households. It is the most commonly recognized measure of inflation.

Contributions

Taxes paid to the state Unemployment Insurance (UI) system from employers based on the wages of covered workers or from the employees themselves.

Core

A densely settled concentration of population, comprising either an urbanized area (of 50,000 or more population) or an urban cluster (of 10,000 to 49,999 population) defined by the Census Bureau, around which a Core Based Statistical Area is defined.

Core Based Statistical Area (CBSA)

Consists of the county or counties or equivalent entities associated with at least one core (urbanized area or urban cluster) of at least 10,000 population, plus adjacent counties having a high degree of social and economic integration with the core as measured through commuting ties with the counties associated with the core.

County Codes

See definition of Federal Information of Processing Standards (FIPS). FIPS county codes are used to report data on the EQUI file and the state's system.

Covered Employment

Employees who are subject to state Unemployment Insurance (UI) laws or the Unemployment Compensation for Federal Employee (UCFE) program. These "covered" employees should be counted in the QCEW micro data if they worked or received pay for the pay period that included the 12th day of the month.

Current Employment Statistics (CES) Survey

A monthly survey of non-farm business establishments used to collect wage and salary employment, worker hours, and payroll, by industry and area. Through the Federal/State cooperative effort, these data are used to compute current monthly employment, hours, and earnings estimates, by industry, for the nation, all 50 states, the District of Columbia, Puerto Rico, the Virgin Islands, and about 450 Metropolitan Areas and Divisions.

Current Population Survey (CPS)

A monthly household survey of the civilian non-institutional population of the United States. This BLS survey provides statistics on employment, unemployment, and wages, by industry,

occupation, and demographic characteristics. Micro data for this survey are collected for BLS by the U.S. Census Bureau.

DASLT

Division of Administrative Statistics and Labor Turnover, also known as the program office for the QCEW and Job Openings and Labor Turnover Survey (JOLTS) programs. This division is responsible for program policy and overall program management.

DBES

Division of Business Establishments Systems. The division within the Directorate of Survey Processing (DSP) that includes staff for the QCEW program, the Occupational Employment Statistics (OES) program, and the Job Openings and Labor Turnover Survey (JOLTS).

Deaths

Establishments that have gone out of business.

Delinquent Accounts

Quarterly Contribution Reports or MWR forms that are missing both employment and wage data or the information is not received in time for use in deliverables.

Deliverable

As specified by the Labor Market Information (LMI) cooperative agreement, any product required to be delivered by the states to the BLS is generally called a "deliverable."

Department of Labor (DOL)

Cabinet-level agency that enforces laws protecting workers, promotes labor-management cooperation, sponsors employment training and placement services, oversees the unemployment insurance system, and produces statistics on the labor force and living conditions.

Disclose or Disclosure

The release of non-confidential information to anyone other than authorized persons or the respondent who provided or is the subject of the data.

Economic Code Change (ECC)

A change in the reporting unit's industry, area, or ownership classification code resulting from the actual conversion or re-location of the unit from one industry, area, or ownership type to another. See Appendix B.

EDB

The EQUI Database (EDB) compiles the EQUI deliverables of the states to aid the national office editing efforts. The EDB only shows what has been submitted to the national office, it does not show any changes made in the state systems that have not been submitted.

Editing

Verification of data for accuracy and conformance with pre-established criteria or tolerance limits.

Electronic Data Interchange (EDI) Center

A BLS center located in Chicago that is responsible for collecting Multiple Worksite Report (MWR) and Current Employment Statistics (CES) data for multi- state employers, mostly with more than 50 worksites, and providing it to the states.

Embargoed Data

Pre-release economic data produced by the BLS.

Employee Contributions

Funds deducted from an employee's pay by the employer and paid with the employer's contribution to the state UI agency. These monies fund the Unemployment Insurance (UI) program.

Employer

The legal entity that either pays the unemployment insurance tax, or is required to reimburse the state unemployment fund for unemployment insurance benefits costs in lieu paying the UI tax.

Employment

The number of covered workers who earned wages during the pay period that includes the 12th of the month. The employment count should include all corporation officials, executives, the supervisory personnel, clerical workers, wage earners, persons on paid vacations or paid sick leave, pieceworkers, part-time workers, and workers earning wages that are nontaxable because the taxable wage limit has been exceeded.

Employment and Training Administration (ETA)

An agency within the U.S. Department of Labor. It oversees the state UI programs and job training and placement services provided by State Workforce Agencies.

Enhanced Quarterly Unemployment Insurance (EQUI) file

A computer file prepared quarterly by state QCEW programs and provided to the national office. These files comprise the primary deliverable under the LMI cooperative agreement. It conveys the names, addresses, employment, wages, as well as other data items, of the establishments covered by state unemployment insurance programs and Unemployment Compensation for Federal Employees.

Enterprise

All establishments having more than 50 percent common direct to indirect ownership.

Establishment

An economic unit that produces goods and services, usually at a single physical location, and engaged in one or predominantly one industry activity.

EUSWeb

A data communication system developed by BLS to support file transfers between states and the BLS.

EXPO

A mainframe state QCEW processing system developed and maintained by the state of Utah and used by the majority of states.

Federal Agency Codes (FACs)

Developed by the Employment and Training Administration (ETA) to properly charge each Federal agency for unemployment benefits received by their former workers under the UCFE program

Federal Employer Identification Number

Nine-digit number assigned by IRS to identify employers for tax collection.

Federal Information Processing Standards (FIPS)

Standards for information processing issued by the National Bureau of Standards in the U.S. Department of Commerce. Includes numeric designations (codes) for geographic areas such as states, counties, and metropolitan areas.

Federal Reserve Board (Fed)

An independent government agency primarily responsible for keeping prices stable. The Fed's primary tool is control over certain short term interest rates. The Fed is a key user of Federal/State Cooperative Programs data.

Federal/State Cooperative Programs

Statistical programs in which the state and Federal governments cooperate in accomplishing program goals. CES, QCEW, OES, LAUS, and OSHS are BLS Federal/State Cooperative Programs.

Firm

A business entity, either corporate or otherwise. May consist of one or several establishments.

Fiscal Year (FY)

A 12-month period established for budgetary and accounting purposes. In the Federal Government, the fiscal year begins October 1 and ends September 30.

FUTA

Federal Unemployment Tax Act. This Act became Chapter 23, Sections 3301-3311, of the U.S. Internal Revenue Code, authorizing the tax imposed on employers with respect to persons they employ for the purpose of funding unemployment insurance benefits. The FUTA made possible the federal/ state system that establishes an employment security program in each state.

GBF

Geographic Base File. A generic term for a computer file of geographic attributes of an area (street names, address ranges, geographic codes, hydrography, railroads and so forth).

GDP

Gross Domestic Product. The total of all goods and services produced by the U.S. economy. GDP is compiled quarterly by the U.S. Department of Commerce. QCEW wage data are used for the final GDP estimates.

Geocode

The geographic information associated with a unique address or centroid, such as longitude and latitude coordinates, census block group, census tract, or county.

GIS

Geographic Information System is an organized collection of computer hardware, software, geographic data, and personnel designed to efficiently capture, store, update, manipulate, analyze, and display all forms of geographically referenced information.

Header Record

Part of the EQUI file, it includes information on the processing state, Year, Quarter, creation date and time of the file and state editing parameters and tolerances. The transaction code is always H on the header record.

Imputation

A process used to estimate employment and wages data when the actual data are not provided by the employer.

Inactive Employer

A unit, not currently reporting employment or paying wages subject to the state's unemployment compensation law that has been terminated, administratively inactivated, or granted permission to suspend filing contribution reports or payment in lieu of contribution reports; or who have paid no wages during the eight calendar quarters immediately preceding the due date of the Quarterly Contributions Report.

Individually Identifiable Data

Any representation of information that permits the identity of the respondent to whom the information applies to be reasonably inferred by either direct or indirect means.

Industry

Describes the type of economic activity engaged in by a group of firms as used in the compilation of economic statistics. The North American Industry Classification System (NAICS) provides numerical classification for industries.

Industry Code

Each establishment is assigned a NAICS code. Using the production process, each establishment is assigned a code that describes their primary economic activity.

Job Openings and Labor Turnover Survey (JOLTS)

A monthly survey of establishments covering payroll employment in nonagricultural industries in both the private and public sectors. Included are total employment, job openings, total hires, resignations, discharges, and other separations. DASLT is the program office and DBES is the project office for this survey.

LABSTAT

BLS's public repository of data, available through the Internet. LABSTAT is a database that contains most published BLS data.

Labor Dispute

Any controversy concerning terms or conditions of employment, or concerning the association or representation of persons in negotiating, fixing, maintaining, changing, or seeking to arrange terms or conditions of employment, regardless of whether or not the disputants stand in the proximate relation of employer and employee.

Labor Market Area (LMA)

An economically integrated geographical unit within which workers may readily change jobs without changing their place of residence. All states are divided into exhaustive LMAs, which usually consist of a county or a group of contiguous counties (except in New England, where township is the smallest government unit).

LAUS Program

Local Area Unemployment Statistics Program. A Federal/state cooperative program that produces employment, labor force, and unemployment estimates for states and local areas.

LMI

Labor Market Information. The body of data available on a particular labor market, including employment and unemployment statistics, occupational statistics, and average hours and earnings data. LMI is also used to refer to the statistical research and analysis offices of the State Workforce Agencies.

LMI Cooperative Agreement

A contract between the State Workforce Agencies and the Bureau of Labor Statistics for the collection and tabulations of Labor Market Information, including the QCEW, CES, OES, and LAUS programs.

Longitudinal Database (LDB)

The LDB is a database of business establishments based on the data submitted quarterly by the states on the EQUI. Every unit on the database contains a unique identifier that allows tracking of individual establishments across quarters. The LDB is the sampling frame for many Bureau of Labor Statistics surveys, and serves as an important resource for labor market research. It is used to produce tabulations for the Business Employment Dynamics.

Longitudinal Employer-Household Dynamics (LEHD)

A U.S. Census program. The LEHD files generated in the states are used as input files for the wage file creator and other wage records programs.

Macro Data

Single establishment (micro) data aggregated to any level.

Mailing Other Address (MOA)

An address for the business where mail is received that is not the UI nor the physical location address.

Master Record

In QCEW micro data, a master record represents the Quarterly Contributions Report data for multi-establishment employers (employers with more than one worksite). A master record's economic data is the summation of data from all of its composite worksites. Master records are not included in macro data aggregations because they duplicate the economic data of the worksite records.

MEEI Code

Codes used to specify the multi-unit status of each reporting unit. These codes are carried on the state's file and reported on the EQUI.

Mean

A number obtained by dividing the sum of the observations by the number of observations. The mean can be weighted or unweighted.

Metropolitan Statistical Area (MSA)

The general concept of a Metropolitan Statistical Area or a Micropolitan Statistical Area is that of an area containing a recognized population nucleus and adjacent communities that have a high degree of integration with that nucleus. The definitions provide a nationally consistent definitions for collecting, tabulating, and publishing Federal statistics for a set of geographic areas. OMB establishes and maintains the definitions of Metropolitan and Micropolitan Statistical Areas, Combined Statistical Areas, and New England City and Town Areas solely for statistical purposes.

A Metropolitan Statistical Area has at least one urbanized area of 50,000 or more population, plus adjacent territory that has a high degree of social and economic integration with the core as measured by commuting ties. Metropolitan Statistical Areas are defined in terms of whole counties (or equivalent entities) in all states including the six New England states. MSAs are revised every ten years.

Micropolitan Statistical Area

A Micropolitan Statistical Area is a type of statistical areas which has at least one urban cluster of at least 10,000 but less than 50,000 population, plus adjacent territory that has a high degree of social and economic integration with the core as measured by commuting ties. Micropolitan

Statistical Areas are defined in terms of whole counties (or equivalent entities), in all states including the six New England states.

Micro Data

Data reported from an individual establishment or reporting unit.

Missing Data

A term typically describing when at least one of the employment (each of three months of employment) and wage fields (total wages, taxable wages, contributions due) is missing. When all are missing the report is considered delinquent.

Moving Average

A series of calculations made by initially taking the simple average, or arithmetic mean, of a consecutive number of items, and then dropping the first item and adding the next item in sequence and averaging, so that the number of items in the series remains constant. This is a continuous process.

Multi-establishment

An account that consists of more than one establishment.

Multiple Worksite Report (MWR)

A standardized data collection form approved by OMB that the state QCEW staff or a print contractor sends employers with multiple worksites. The Multiple Worksite Report allows the QCEW program to obtain worksite-level information.

MWR Web

A QCEW web-based processing system that allows small to moderately sized multiple worksite reporters to report and transmit their quarterly MWR data to BLS via the internet. EDI reporters are excluded from MWR Web reporting. Information gathered via MWR Web is fed back to the states, loaded to their processing systems, and transmitted to the national office on the EQUI.

New Unit

Newly reporting account or unit that may or may not be linked to an existing reporting account.

NAICS

North American Industry Classification System, the system used to classify the primary economic activity of the establishment.

NCA Form

An OMB approved form used to collect data about unclassified establishments that can then be used to assign an industry code.

Non-Economic Code Change (NECC)

A change in a reporting unit's industry, area, or ownership classification code that:

1. Does not result from an actual conversion or re-location of the unit from one industry, area, or ownership type to another.
2. Results from an actual conversion or re-location that was discovered by QCEW staff long after the data could be entered on the state system.
3. Lacks sufficient evidence to be classified as an economic code change.

Nonresponse

Failure to submit response with usable data from eligible units.

Nontaxable Wages

That part of an employee's total wages that is in excess of wages that are taxable under the state Unemployment Insurance law.

Number of Wage Records

The number of unique social security numbers appearing on the wage report for the quarter. Also referred to as the Wage Record Count.

NVM (NAICS Verification Multi-establishment) Form

An OMB approved form used to verify the industry and geographic codes of Multi-establishment employers as part of the Annual Refiling Survey.

NVM Web

Used in conjunction with MWR Web, NVM web allows current MWR reporters to verify and/or update the NAICS code of their worksites.

NVS (NAICS Verification Single-establishment) Form

An OMB approved form used to verify the industry and geographic codes of Single establishment employers as part of the Annual Refiling Survey.

Numbered Memoranda

A series of technical memoranda issued for the purpose of disseminating information to regional offices (R-memos) and states (S-memos) on new developments in the Fed/State programs, changes in operating procedures, and updates to manuals.

OES Program

Occupational Employment Statistics Program. A Federal/State cooperative program that collects detailed occupational and wage data by industry and area.

Office of Employment and Unemployment Statistics (OEUS)

The BLS office that includes the “program offices” of the Federal/State Cooperative Programs: Division of Current Employment Statistics (CES), Division of Administrative Statistics and Labor Turnover (DASLT), and Division of Local Area Unemployment Statistics (LAUS). OEUS also includes other divisions: Division of Labor Force Statistics (DLFS), Statistical Methods Staff (SMS), and Division of Data Development and Publications (DDDP).

Office of Field Operations (OFO)

Coordinates the work of regional offices and acts as a liaison between the national office and the regional offices. Regional offices are part of the office of field operations.

Office of Management and Budget (OMB)

Located in the Executive Office of the President, this agency prepares the President’s budget with the Council of Economic Advisors and the Treasury Department. OMB also oversees all Federal data collection. Among other duties, this federal agency is responsible for enforcing the Paperwork Reduction Act and, in so doing, must approve all survey and data collection forms that represent a reporting burden on employers and the general public.

Office of Technology and Survey Processing (OTSP)

The national office that includes the various "project offices" for the QCEW, Current Employment Statistics (CES), Occupational Employment Statistics (OES), and Local Area Unemployment Statistics (LAUS) programs. Also responsible for LABSTAT development and maintenance of the Bureau of Labor Statistics (BLS) LAN.

Organization Type Indicator

Codes used by several states to further refine private industry businesses in to sole proprietorships, corporations, partnerships or other legal business arrangements.

Out-of-Business (OOB)

Status assigned to a unit that was once active but that has permanently ceased to conduct business or perform services.

Ownership

Codes that designate businesses as private or government accounts, The ownership code permits separate or combined publication and analysis of private sector employment and wage data.

P-Percent

A complex formula designed to avoid disclosure of large, dominant establishments.

Physical Location Address (PLA)

Where the business is actually located and conducting business. This is the address if the place where business is conducted and deliveries received. This address cannot be a Post Office Box.

Predecessor

The previous owner of a business establishment. In QCEW microdata, a predecessor is an establishment that previously reported under one UI Account Number or Reporting Unit Number

which is now being reported under a different UI Account Number/Reporting Unit Number configuration.

Predecessor/Successor Relationship

The QCEW program defines a predecessor/successor relationship as one where the successor (the new owner of an establishment) performs similar operations to the predecessor (the previous owner of an establishment). These operations are frequently, but not necessarily, performed at the same location as the predecessor.

Primary County

The county with the largest employment for a multicounty employer.

Private Sector Employment

That employment not accounted for in governmental agencies.

Professional Employer Organization (PEO)

A firm that provides a service under which an employer can outsource employee management tasks, such as employee benefits, payroll and workers' compensation, recruiting, risk/safety management, and training and development. For QCEW purposes, a PEO will report multiple employers under the same UI account number within a state.

Program Offices

Generic term for the divisions within OEUS responsible for the various Fed/State survey programs. See DASLT.

Proration

Worksite data derived by applying previous ratios of employment and wages to current data.

QCEW Program

A Federal/State cooperative program that collects and compiles employment and wage data for workers covered by state unemployment insurance (UI) laws, and Federal civilian workers covered by Unemployment Compensation for Federal Employees (UCFE).

Quarterly Contribution Report (QCR)

A mandatory report filed quarterly by almost all U.S. employers to the SWA for UI purposes. Employers report the number of employees, total quarterly wages, and UI taxable wages, and compute their UI tax liability for each quarter. Used by the QCEW program as the source of most data on the state QCEW database.

Reference Date

The reference date of a sample frame is the date when the characteristics of the population existed on the frame. The reference date of a survey or file, however, is the date for which the respondents are requested to submit the data.

Regional Office (R.O.)

Term used to refer to the offices and employees of the Bureau of Labor Statistics in the field office locations.

Report of Federal Employment and Wages (RFEW)

A standardized data collection form (BLS 3021) that the state QCEW staff sends federal government employers with multiple worksites. The RFEW allows the QCEW program to obtain worksite level information from federal agencies and reporting agents for federal employers from the state administrative files of the Unemployment Compensation for Federal Employers.

Reporting Unit

A reporting unit is the most detailed economic unit for which data are reported by the employer. Usually, a reporting unit is an individual establishment, but sometimes two or more establishments are reported as a single unit.

Respondent

A person who, or organization that, is requested or required to supply information to the BLS, is the subject of information requested or required to be supplied to the BLS, or provides that information to the BLS.

Sample

A subset of a universe. Usually selected as representative of the universe.

Sample Survey

A survey in which only a sample or part of the population is studied.

Scoring

Method used to prioritize records for additional review.

Seasonal Adjustment

Adjustment of time-series data to eliminate the effect of seasonal variations. Examples of such variations include school terms, holidays, yearly weather patterns, etc.

Secondary Non-disclosure

Prevents the ready determination of data for sensitive cells suppressed by the arithmetic calculation using other cells in the hierarchy.

Series Break

A large change in the level of a time series resulting from: a major change in methodology; a major change in industry definition; a major industry or area coding error; the permanent loss of a major reporter; area redefinition. If a series has been broken, data before the break are not comparable to data after the break.

SLED

System for processing Large Volume Employment Data is a system that handles the central collection of Multiple Worksite Report (MWR) data at the Chicago Electronic Data Interchange (EDI) center. This system processes QCEW program data that is collected from multi- state employers and prepares it for distribution to the appropriate states. The system updates incoming data, performs edits, aggregates records, and builds historical files.

SMS

Statistical Methods Staff. A division within OEUS that researches and sets statistical standards for Federal/State surveys.

State Workforce Agency (SWA)

A generic name for the state agency usually responsible for three activities:

1. Unemployment Insurance (UI) Program - UI tax collection, administration, and determination and payment of unemployment benefits.
2. LMI -- collection, analysis, and publication of labor market information.
3. Employment or Job Service Program - an exchange for workers seeking work and employers seeking workers.

StateWeb

BLS state Intranet where technical memoranda, program documentation, and Policy Council information are stored.

Status Determination Form

(Also called Status Report) A mandatory form filed by most U.S. employers with the SWA when they begin business operations. Information on the form is used to determine the employer's UI liability and establish a UI account.

Strike

A work stoppage by employees acting together in an attempt to bring pressure on management to give in to their demands concerning wages, working conditions, union recognition, or other issues.

Successor

The new owner of a business establishment. In QCEW micro data, a successor is an establishment that is now reported (or that will be reporting) under one UI Account Number or Reporting Unit Number, that was being reported under a different UI Account Number/Reporting Unit Number configuration.

Summary Management Report (SMR)

A report generated by the state processing systems that shows the progress in meeting the necessary response rates for the Annual Refiling Survey.

Supersector

BLS publication aggregation of industries.

Survey

A study of all or a portion of the whole, conducted for the purpose of making generalized statements about the whole.

Survey Design

All procedures used in a survey, including, but not limited to, frame development, sample design, form design, estimation, and tabulation.

Taxable Wages

The portion of total UI-covered wages subject to state Unemployment Insurance tax.

Time Series

A variable in which the values are successive observations over time.

Total Wages

The total amount of wages paid or payable to covered workers for services performed during the quarter.

Trailer Record

Includes summary information on the number of records in the EQUI transmission as well as establishment counts and employment and wage totals by year, quarter, and ownership. The Transaction Code is always T on the trailer record. BLS uses the trailer to compare the expected output of the EQUI file to the actual output to ensure that no records were lost either when the file was created or when it was loaded.

UCFE

Unemployment Compensation for Federal Employees. The federal program that provides temporary financial assistance to eligible federal workers who become unemployed. (Federal employees are not covered under state-administered Unemployment Insurance programs.)

UI

Unemployment Insurance. Social welfare program first instituted in the Great Depression to provide temporary financial assistance to eligible unemployed workers. Unemployment insurance programs are administered by state Employment Security Agencies under state law, subject to federal minimum standards.

UI Account Number

The number which identifies the state Unemployment Insurance account for which an establishment pays UI taxes. These taxes fund Unemployment Insurance benefits for eligible workers in that state. UI account numbers are assigned by the State Workforce Agency's UI Tax Unit. Generally, one UI account number is assigned per firm per state, regardless of how many establishments the firm has in the state.

UI Tax Address

The address provided to the Unemployment Insurance office by a new business for the purpose of reporting Quarterly Contributions Reports.

U.S. Census Bureau

A Federal statistical agency that is part of the U.S. Department of Commerce. As its name implies, the Census Bureau conducts the decennial census of population and housing and monthly, annual and/or quinquennial surveys of all major industry groups. The Census Bureau also conducts the monthly Current Population Survey (CPS) in cooperation with BLS. Data from this survey are the source of unemployment statistics.

Universe

The entire population to be measured.

Wage Records

An attachment to employer's Quarterly Contribution Reports that lists the Social Security numbers, the individual quarterly wages, and in some instances names of all UI-covered employees on the payroll.

WebNAICS

A tool housed on the BLS website that is designed to easily search NAICS codes for the BLS and state systems.

WIN

A client/server QCEW processing system developed and maintained by the state of Maine, and used as the standardized processing system in some state. It is a PC-based system that operates in a Windows environment.