



Centers for Medicaid and CHIP Services (CMCS)

Transformed Medicaid Statistical Information System (T-MSIS)

~~Data Dictionary Record Segment Relationships~~

~~Version: v2.4.0~~

~~December 04, 2020~~

List of Tables

Table 1: T-MSIS Record Segment Definitions	2
--	---

List of Figures

Figure 1: Claim IP File—Claim Record Segment Relationships	9
Figure 2: Claim LT File—Claim Record Segment Relationships	10
Figure 3: Claim OT File—Claim Record Segment Relationships	11
Figure 4: Claim RX File—Claim Record Segment Relationships	12

Figure 5: Eligible File—Eligible Person Record Segment Relationships.....13

Figure 6: Provider File—Provider Record Segment Relationships15

Figure 7: Managed Care File—Managed Care Entity Record Segment Relationships.....17

Figure 8: Third-Party Liability (TPL) File—TPL Record Segment Relationships.....19

~~T-MSIS~~ **Record Segment Definitions and Relationships**

Version: v4.0.0

2024-06-03

PRA Disclosure Statement: The Transformed Medicaid Statistical Information System (T-MSIS) is used to assist the Centers for Medicare & Medicaid Services (CMS) with monitoring and oversight of Medicaid and CHIP programs, to enable evaluation of demonstrations under section 1115 of the Social Security Act and to calculate quality measures and other metrics, including those reported through the new Medicaid and CHIP Scoreboard. Section 4735 of the Balanced Budget Act of 1997 included a statutory requirement for states to submit claims data, enrollee encounter data, and supporting information. Section 6504 of the Affordable Care Act strengthened this provision by requiring states to include data elements the Secretary determines necessary for program integrity, program oversight, and administration. Under the Privacy Act of 1974 any personally identifying information obtained will be kept private to the extent of the law. According to the Paperwork Reduction Act of 1995, no persons are required to respond to a collection of information unless it displays a valid OMB control number. **The valid OMB control number for this information collection is 0938-0345 (Expires: 03/31/2026).** The time required to complete this information collection is estimated to average 10 hours per response, including the time to review instructions, search existing data resources, gather the data needed, and complete and review the information collection. If you have comments concerning the accuracy of the time estimate(s) or suggestions for improving this form, please write to: CMS, 7500 Security Boulevard, Attn: PRA Reports Clearance Officer, Mail Stop C4-26-05, Baltimore, Maryland 21244-1850. **This document**

Table of Contents

<u>Table of Contents</u>	3
<u>T-MSIS Record Segment Descriptions</u>	4
<u>Record Segment Relationships Figures</u>	28
<u>Claim IP File – Record Segment Relationships</u>	28
<u>Claim LT File – Record Segment Relationships</u>	29
<u>Claim OT File – Claim Record Segment Relationships</u>	32
<u>Claim RX File – Claim Record Segment Relationships</u>	33
<u>Eligible File – Eligible Person Record Segment Relationships</u>	36
<u>Financial Transactions File – Record Segment Relationships</u>	39
<u>Managed Care File – Managed Care Entity Record Segment Relationships</u>	40
<u>Provider File – Provider Record Segment Relationships</u>	41
<u>Third-Party Liability File – Record Segment Relationships</u>	47

T-MSIS Record Segment Descriptions

Table 1 contains definitions and diagrams that depict descriptions of each T-MSIS Record Segment Relationships. On all joins, Figures 1 through 9 illustrate intra-file segment relationships.

For ELG, MCR, PRV, and TPL files, the effective date of the child segment must fall completely within the set of effective-end date span of the active parent records-segment(s). There shall be no dates where a child segment is active without a corresponding active parent segment.

The T-MSIS Financial Transactions file (FTX) is intended to capture any financial transactions that are not either a fee-for-service (FFS) claim, a managed care encounter, or a type of financial transaction explicitly excluded from T-MSIS. FFS claims and managed care encounters must be mapped and reported to the T-MSIS IP, LT, OT, or RX files as appropriate.

States are required to submit transactions for the following expenditures to T-MSIS:

- All Medicaid and CHIP based medical assistance (as defined by MBES/MACFin) expenditures and recoupments between the state, a provider, a managed care plan, broker, and/or a beneficiary except for:
 - quarterly Drug Rebates collected from Manufacturers,
 - monthly Medicare Part A or Part B premium payments
 - provider-level (not beneficiary/service specific) monthly, quarterly, bi-annual, or annual lump sum Disproportionate Share Hospital (DSH), Upper Payment Limit (UPL) Supplemental, or Graduate Medical Education (GME) payments
- Non-emergency medical transportation (NEMT) broker payments, even if they were claims via MBES/MACFin as an administrative cost - all other administrative costs (as defined by MBES/MACFin) are excluded from T-MSIS
- All payments and recoupments from a managed care plan to their providers and subcontractors

Table 1: T-MSIS Record Segment Definitions for File Types

File Name	Record Segment Name	Record Identifier	Record Segment Definition	Record Segment Length
Claim Inpatient File	FILE-HEADER-RECORD-IP	GIP00001	A record containing metadata necessary to identify the file itself, when it was created and the number of records it contains.	2,100
Claim Inpatient File	CLAIM-HEADER-RECORD-IP	GIP00002	A record to capture data about an inpatient claim or encounter that applies to the claim in its totality.	2,100
Claim Inpatient File	CLAIM-LINE-RECORD-IP	GIP00003	A record to capture data about specific goods or services rendered to a Medicaid/CHIP enrollee during the hospital stay.	2,100
Claim Long-term Care File	FILE-HEADER-RECORD-LT	GLT00001	A record containing metadata necessary to identify the file itself, when it was created and the number of records it contains.	1,900

File Name	Record Segment Name	Record Identifier	Record Segment Definition	Record Segment Length
Claim Long-term Care File	CLAIM-HEADER-RECORD-LT	CLT00002	A record to capture data about a long-term care claim or encounter that applies to the claim in its totality.	1,900
Claim Long-term Care File	CLAIM-LINE-RECORD-LT	CLT00003	A record to capture data about specific goods or services rendered to a Medicaid/CHIP enrollee during a long-term care stay.	1,900
Claim Other File	FILE-HEADER-RECORD-OT	COT00001	A record containing metadata necessary to identify the file itself, when it was created and the number of records it contains.	1,750
Claim Other File	CLAIM-HEADER-RECORD-OT	COT00002	A record to capture data about another type of claim or encounter (besides IP, LT, and RX) that applies to the claim in its totality.	1,750
Claim Other File	CLAIM-LINE-RECORD-OT	COT00003	A record to capture data about specific goods or services rendered to a Medicaid/CHIP enrollee during an outpatient visit.	1,750
Claim Prescription File	FILE-HEADER-RECORD-RX	GRX00001	A record containing metadata necessary to identify the file itself, when it was created and the number of records it contains.	1,450
Claim Prescription File	CLAIM-HEADER-RECORD-RX	CRX00002	A record to capture data about a pharmacy claim or encounter that applies to the claim in its totality.	1,450
Claim Prescription File	CLAIM-LINE-RECORD-RX	CRX00003	A record to capture data about specific prescription goods or services rendered to a Medicaid/CHIP enrollee.	1,450
Eligible File	FILE-HEADER-RECORD-ELIGIBILITY	ELG00001	A record containing metadata necessary to identify the file itself, when it was created and the number of records it contains.	1,000
Eligible File	PRIMARY-DEMOGRAPHICS-ELIGIBILITY	ELG00002	A record to capture basic demographic information about the individual.	1,000
Eligible File	VARIABLE-DEMOGRAPHICS-ELIGIBILITY	ELG00003	A record to capture additional demographic information that is more prone to periodic changes than primary demographics.	1,000
Eligible File	ELIGIBLE-CONTACT-INFORMATION	ELG00004	A record to capture addresses and phone numbers of the individual.	1,000

File Name	Record Segment Name	Record Identifier	Record Segment Definition	Record Segment Length
Eligible File	ELIGIBILITY-DETERMINANTS	ELG00005	A record to capture factors that influence an individual's eligibility for basic Medicaid/CHIP, as well as the various waivers and demonstrations.	1,000
Eligible File	HEALTH-HOME-SPA-PARTICIPATION-INFORMATION	ELG00006	A record to capture the eligible person's participation in the state's health-home initiative.	1,000
Eligible File	HEALTH-HOME-SPA-PROVIDERS	ELG00007	A record to capture the identity of the health home entity in which the eligible person is enrolled, as well as the identity of the provider with primary responsibility for coordinating the delivery of health home services.	1,000
Eligible File	HEALTH-HOME-CHRONIC-CONDITIONS	ELG00008	A record to capture an eligible person's chronic conditions that qualified him/her for participation in the health home initiative.	1,000
Eligible File	LOCK-IN-INFORMATION	ELG00009	A record to capture the provider, or providers, to whom the eligible person is restricted, as well as the time periods during which the lock-in provisions are in force.	1,000
Eligible File	MFP-INFORMATION	ELG00010	A record to capture information about an eligible person's participation in the Money Follows the Person demonstration program.	1,000
Eligible File	STATE-PLAN-OPTION-PARTICIPATION	ELG00011	A record to capture the identity of the State Plan Options in which an eligible person is enrolled.	1,000
Eligible File	WAIVER-PARTICIPATION	ELG00012	A record to capture the identity of the waivers in which an eligible person is enrolled.	1,000
Eligible File	LTSS-PARTICIPATION	ELG00013	A record to capture the level of care an eligible person receives at various points in time while in a long term care facility.	1,000
Eligible File	MANAGED-CARE-PARTICIPATION	ELG00014	A record to capture information about an eligible person's enrollment in a managed care plan.	1,000
Eligible File	ETHNICITY-INFORMATION	ELG00015	A record to capture information about an eligible person's ethnicity.	1,000

File Name	Record Segment Name	Record Identifier	Record Segment Definition	Record Segment Length
Eligible File	RACE-INFORMATION	ELG00016	A record to capture information about an eligible person's race.	1,000
Eligible File	DISABILITY-INFORMATION	ELG00017	A record to capture information about an eligible person's disabilities.	1,000
Eligible File	1115A-DEMONSTRATION-INFORMATION	ELG00018	A record to capture an eligible person's 1115A participation.	1,000
Eligible File	HCBS-CHRONIC-CONDITIONS-NON-HEALTH-HOME	ELG00020	A record to capture an eligible person's chronic conditions for which an eligible person is receiving home and community-based care.	1,000
Eligible File	ENROLLMENT-TIME-SPAN-SEGMENT	ELG00021	A record to capture the eligible person's type of enrollment and time spans of enrollment.	1,000
Eligible File	ELG-IDENTIFIERS	ELG00022	A record to capture the identifiers assigned to a beneficiary by various entities.	1,000
Managed Care Plan Information File	FILE-HEADER-RECORD-MANAGED-CARE	MCR00001	A record containing metadata necessary to identify the file itself, when it was created and the number of records it contains.	1,000
Managed Care Plan Information File	MANAGED-CARE-MAIN	MCR00002	A record to capture basic, generally static information about a managed care entity.	1,000
Managed Care Plan Information File	MANAGED-CARE-LOCATION-AND-CONTACT-INFO	MCR00003	A record to capture addresses, phone numbers, fax numbers, and email addresses of the managed care organization.	1,000
Managed Care Plan Information File	MANAGED-CARE-SERVICE-AREA	MCR00004	A record to capture the zip codes, counties, or other geographic descriptors that define the managed care entity's service area.	1,000
Managed Care Plan Information File	MANAGED-CARE-OPERATING-AUTHORITY	MCR00005	A record to capture information about the operating authority, waivers and demonstrations under which a managed care entity is contracted with the state.	1,000
Managed Care Plan Information File	MANAGED-CARE-PLAN-POPULATION-ENROLLED	MCR00006	A record to capture the identity of the Medicaid/CHIP eligibility groups that the managed care entity is authorized to enroll.	1,000
Managed Care Plan Information File	MANAGED-CARE-ACCREDITATION-ORGANIZATION	MCR00007	A record to capture information concerning the accreditations that the managed care entity has.	1,000

File Name	Record Segment Name	Record Identifier	Record Segment Definition	Record Segment Length
Managed Care Plan Information File	NATIONAL-HEALTH-CARE-ENTITY-ID-INFO	MCR00008	A record to capture the national health plan identifiers associated with the managed care entity.	1,000
Managed Care Plan Information File	CHPID-SHPID-RELATIONSHIPS	MCR00009	A record to link a managed care entity Sub-Health Plan IDs with the appropriate Controlling Health Plan IDs.	1,000
Provider File	FILE HEADER-RECORD-PROVIDER	PRV00001	A record containing metadata necessary to identify the file itself, when it was created and the number of records it contains.	1,100
Provider File	PROV-ATTRIBUTES-MAIN	PRV00002	A record to capture basic, generally static information about each provider. A provider is an individual person (medical or non-medical), a group of individuals, or an organization (e.g. institution, facility, agency, hospital, nursing facility, home health agency, school, or transportation organization) that delivers or facilitates health-related treatments, health care services, or living supports.	1,100

File Name	Record Segment Name	Record Identifier	Record Segment Definition	Record Segment Length
Provider File	PROV-LOCATION-AND-CONTACT-INFO	PRV00003	A record to capture addresses, phone numbers, and email addresses of the provider. Each PROV-LOCATION-AND-CONTACT-INFO record segment represents the set of contact information for a single provider location. The state can enter as many sets of contact information (i.e., multiple PROV-LOCATION-AND-CONTACT-INFO record segments) as it considers necessary. The value selected for the ADDR-TYPE field describes the type of contact information on that particular record (e.g., provider service location, provider billing address, etc.). The PROV-LOCATION-ID differentiates one PROV-LOCATION-AND-CONTACT-INFO record segment from another when the ADDR-TYPE value on both records is the same.	1,100
Provider File	PROV-LICENSING-INFO	PRV00004	A record to capture licensing and accreditation information relevant to the provider.	1,100
Provider File	PROV-IDENTIFIERS	PRV00005	A record to capture the identifiers assigned to the provider entity by various governmental, professional, and payer entities.	1,100
Provider File	PROV-TAXONOMY-CLASSIFICATION	PRV00006	A record to classify the provider into areas of specialty, as well as the authorized categories of service for which the provider entity has been authorized by the state to render to Medicaid/CHIP eligibles.	1,100
Provider File	PROV-MEDICAID-ENROLLMENT	PRV00007	A record to capture the provider's periods of participation in the state's Medicaid/CHIP programs, and the reason for a change in enrollment status.	1,100
Provider File	PROV-AFFILIATED-GROUPS	PRV00008	A record to capture a provider's relationship(s) with other provider(s).	1,100

File Name	Record Segment Name	Record Identifier	Record Segment Definition	Record Segment Length
Provider File	PROV-AFFILIATED-PROGRAMS	PRV00009	A record to capture the Medicaid/CHIP health plans, waivers, health home entities, etc. that the provider entity is associated with.	1,100
Provider File	PROV-BED-TYPE-INFO	PRV00010	A record to capture the number of beds available for various categories of bed at provider entities that are facilities.	1,100
Third-party Liability File	FILE-HEADER-RECORD-TPL	TPL00001	A record containing metadata necessary to identify the file itself, when it was created and the number of records it contains.	900
Third-party Liability File	TPL-MEDICAID-ELIGIBLE-PERSON-MAIN	TPL00002	A record to capture basic, generally static information to identify Medicaid/CHIP enrollees for whom third party funds may be available to offset some or all of their Medicaid/CHIP costs.	900
Third-party Liability File	TPL-MEDICAID-ELIGIBLE-PERSON-HEALTH-INSURANCE-COVERAGE-INFO	TPL00003	A record to capture insurance policy information needed to facilitate pursuit of the third party liability.	900
Third-party Liability File	TPL-MEDICAID-ELIGIBLE-PERSON-HEALTH-INSURANCE-COVERAGE-CATEGORIES	TPL00004	A record to capture TPL insurance coverage information to support the applicability assessment of the third party insurance coverage to the Medicaid/CHIP costs incurred on behalf of the Medicaid/CHIP enrollee.	900
Third-party Liability File	TPL-MEDICAID-ELIGIBLE-OTHER-THIRD-PARTY-COVERAGE-INFORMATION	TPL00005	A record to flag Medicaid/CHIP enrollees who potentially have non insurance sources of funds that could be used to offset Medicaid/CHIP expenditures.	900
Third-party Liability File	TPL-ENTITY-CONTACT-INFORMATION	TPL00006	A record to capture addresses and phone numbers of the entity providing TPL insurance coverage.	900
File Name	Record Segment Name	Record Identifier	Record Segment Definition	FLF Record Segment Length
Claim Inpatient File	FILE-HEADER-RECORD-IP	CIP00001	A record segment containing metadata necessary to identify the file itself, when it was created and the number of records it contains.	2,400

File Name	Record Segment Name	Record Identifier	Record Segment Definition	Record Segment Length
<u>Claim Inpatient File</u>	<u>CLAIM-HEADER-RECORD-IP</u>	<u>CIP00002</u>	<u>A record segment to capture data about an acute care inpatient facility claim or encounter that applies to the claim in its totality.</u>	<u>2,400</u>
<u>Claim Inpatient File</u>	<u>CLAIM-LINE-RECORD-IP</u>	<u>CIP00003</u>	<u>A record segment to capture data about specific goods or services rendered to a Medicaid/CHIP enrollee during the hospital stay.</u>	<u>2,400</u>
<u>Claim Inpatient File</u>	<u>CLAIM-DX-IP</u>	<u>CIP00004</u>	<u>A record segment to capture data about the diagnosis code(s) associated with a claim.</u>	<u>2,400</u>
<u>Claim Long-term Care File</u>	<u>FILE-HEADER-RECORD-LT</u>	<u>CLT00001</u>	<u>A record segment containing metadata necessary to identify the file itself, when it was created and the number of records it contains.</u>	<u>2,200</u>
<u>Claim Long-term Care File</u>	<u>CLAIM-HEADER-RECORD-LT</u>	<u>CLT00002</u>	<u>A record segment to capture data about an inpatient long-term care facility claim or encounter that applies to the claim in its totality.</u>	<u>2,200</u>
<u>Claim Long-term Care File</u>	<u>CLAIM-LINE-RECORD-LT</u>	<u>CLT00003</u>	<u>A record segment to capture data about specific goods or services rendered to a Medicaid/CHIP enrollee during a long-term care stay.</u>	<u>2,200</u>
<u>Claim Long-term Care File</u>	<u>CLAIM-DX-LT</u>	<u>CLT00004</u>	<u>A record segment to capture data about the diagnosis code(s) associated with a claim.</u>	<u>2,200</u>
<u>Claim Other File</u>	<u>FILE-HEADER-RECORD-OT</u>	<u>COT00001</u>	<u>A record segment containing metadata necessary to identify the file itself, when it was created and the number of records it contains.</u>	<u>2,100</u>
<u>Claim Other File</u>	<u>CLAIM-HEADER-RECORD-OT</u>	<u>COT00002</u>	<u>A record segment to capture data about another type of claim or encounter (besides IP, LT, and RX) that applies to the claim in its totality.</u>	<u>2,100</u>
<u>Claim Other File</u>	<u>CLAIM-LINE-RECORD-OT</u>	<u>COT00003</u>	<u>A record segment to capture data about specific goods or services rendered to a Medicaid/CHIP enrollee during an outpatient visit.</u>	<u>2,100</u>

File Name	Record Segment Name	Record Identifier	Record Segment Definition	Record Segment Length
<u>Claim Other File</u>	<u>CLAIM-DX-OT</u>	<u>COT00004</u>	<u>A record segment to capture data about the diagnosis code(s) associated with a claim.</u>	<u>2,100</u>
<u>Claim Prescription File</u>	<u>FILE-HEADER-RECORD-RX</u>	<u>CRX00001</u>	<u>A record segment containing metadata necessary to identify the file itself, when it was created and the number of records it contains.</u>	<u>1,600</u>
<u>Claim Prescription File</u>	<u>CLAIM-HEADER-RECORD-RX</u>	<u>CRX00002</u>	<u>A record segment to capture data about a pharmacy claim or encounter that applies to the claim in its totality.</u>	<u>1,600</u>
<u>Claim Prescription File</u>	<u>CLAIM-LINE-RECORD-RX</u>	<u>CRX00003</u>	<u>A record segment to capture data about specific prescription goods or services rendered to a Medicaid/CHIP enrollee.</u>	<u>1,600</u>
<u>Claim Prescription File</u>	<u>CLAIM-DX-RX</u>	<u>CRX00004</u>	<u>A record segment to capture data about the diagnosis code(s) associated with a claim.</u>	<u>1,600</u>
<u>Eligible File</u>	<u>FILE-HEADER-RECORD-ELIGIBILITY</u>	<u>ELG00001</u>	<u>A record segment containing metadata necessary to identify the file itself, when it was created and the number of records it contains.</u>	<u>1,000</u>
<u>Eligible File</u>	<u>PRIMARY-DEMOGRAPHICS-ELIGIBILITY</u>	<u>ELG00002</u>	<u>A record segment to capture basic demographic information about the individual.</u>	<u>1,000</u>
<u>Eligible File</u>	<u>VARIABLE-DEMOGRAPHICS-ELIGIBILITY</u>	<u>ELG00003</u>	<u>A record segment to capture additional demographic information that is more prone to periodic changes than primary demographics.</u>	<u>1,000</u>
<u>Eligible File</u>	<u>ELIGIBLE-CONTACT-INFORMATION</u>	<u>ELG00004</u>	<u>A record segment to capture addresses and phone numbers of the individual.</u>	<u>1,000</u>
<u>Eligible File</u>	<u>ELIGIBILITY-DETERMINANTS</u>	<u>ELG00005</u>	<u>A record segment to capture factors that influence an individual's eligibility for basic Medicaid/CHIP, as well as the various waivers and demonstrations.</u>	<u>1,000</u>
<u>Eligible File</u>	<u>HEALTH-HOME-SPA-PARTICIPATION-INFORMATION</u>	<u>ELG00006</u>	<u>A record segment to capture the eligible person's participation in the state's health home initiative.</u>	<u>1,000</u>

File Name	Record Segment Name	Record Identifier	Record Segment Definition	Record Segment Length
<u>Eligible File</u>	<u>HEALTH-HOME-SPA-PROVIDERS</u>	<u>ELG00007</u>	<u>A record segment to capture the identity of the health home entity in which the eligible person is enrolled, as well as the identity of the provider with primary responsibility for coordinating the delivery of health home services.</u>	<u>1,000</u>
<u>Eligible File</u>	<u>HEALTH-HOME-CHRONIC-CONDITIONS</u>	<u>ELG00008</u>	<u>A record segment to capture an eligible person's chronic conditions that qualified him/her for participation in the health home initiative.</u>	<u>1,000</u>
<u>Eligible File</u>	<u>LOCK-IN-INFORMATION</u>	<u>ELG00009</u>	<u>A record segment to capture the provider, or providers, to whom the eligible person is restricted, as well as the time periods during which the lock-in provisions are in force.</u>	<u>1,000</u>
<u>Eligible File</u>	<u>MFP-INFORMATION</u>	<u>ELG00010</u>	<u>A record segment to capture information about an eligible person's participation in the Money Follows the Person demonstration program.</u>	<u>1,000</u>
<u>Eligible File</u>	<u>STATE-PLAN-OPTION-PARTICIPATION</u>	<u>ELG00011</u>	<u>A record segment to capture the identity of the State Plan Options in which an eligible person is enrolled.</u>	<u>1,000</u>
<u>Eligible File</u>	<u>WAIVER-PARTICIPATION</u>	<u>ELG00012</u>	<u>A record segment to capture the identity of the waivers in which an eligible person is enrolled.</u>	<u>1,000</u>
<u>Eligible File</u>	<u>LTSS-PARTICIPATION</u>	<u>ELG00013</u>	<u>A record segment to capture the level of care an eligible person receives at various points in time while in a long-term care facility.</u>	<u>1,000</u>
<u>Eligible File</u>	<u>MANAGED-CARE-PARTICIPATION</u>	<u>ELG00014</u>	<u>A record segment to capture information about an eligible person's enrollment in a managed care plan.</u>	<u>1,000</u>
<u>Eligible File</u>	<u>ETHNICITY-INFORMATION</u>	<u>ELG00015</u>	<u>A record segment to capture information about an eligible person's ethnicity.</u>	<u>1,000</u>
<u>Eligible File</u>	<u>RACE-INFORMATION</u>	<u>ELG00016</u>	<u>A record segment to capture information about an eligible person's race.</u>	<u>1,000</u>
<u>Eligible File</u>	<u>DISABILITY-INFORMATION</u>	<u>ELG00017</u>	<u>A record segment to capture information about an eligible person's disabilities.</u>	<u>1,000</u>

File Name	Record Segment Name	Record Identifier	Record Segment Definition	Record Segment Length
<u>Eligible File</u>	<u>1115A-DEMONSTRATION- INFORMATION</u>	<u>ELG00018</u>	<u>A record segment to capture an eligible person's 1115A participation.</u>	<u>1,000</u>
<u>Eligible File</u>	<u>HCBS-CHRONIC- CONDITIONS-NON-HEALTH- HOME</u>	<u>ELG00020</u>	<u>A record segment to capture an eligible person's chronic conditions for which an eligible person is receiving home and community-based care.</u>	<u>1,000</u>
<u>Eligible File</u>	<u>ENROLLMENT-TIME-SPAN- SEGMENT</u>	<u>ELG00021</u>	<u>A record segment to capture the eligible person's type of enrollment and time spans of enrollment.</u>	<u>1,000</u>
<u>Eligible File</u>	<u>ELG-IDENTIFIERS</u>	<u>ELG00022</u>	<u>A record segment to capture the identifiers assigned to a beneficiary by various entities.</u>	<u>1,000</u>
<u>Eligible File</u>	<u>SOGI</u>	<u>ELG00023</u>	<u>A record segment to capture the sexual orientation and gender identity of the individual. For more information, see the CMCS Information Bulletin (CIB) dated November 9, 2023 with subject "Guidance on Adding Sexual Orientation and Gender Identity Questions to State Medicaid and CHIP Applications for Health Coverage."</u>	<u>1,000</u>
<u>Financial Transaction File</u>	<u>FILE-HEADER-RECORD-FTX</u>	<u>FTX00001</u>	<u>A record segment containing metadata necessary to identify the file itself, when it was created and the number of records it contains.</u>	<u>2,500</u>

File Name	Record Segment Name	Record Identifier	Record Segment Definition	Record Segment Length
<u>Financial Transaction File</u>	<u>INDIVIDUAL-CAPITATION-PMPM</u>	<u>FTX00002</u>	<p><u>A record segment to capture individual capitation payments and sub-capitation payments. Per 42 CFR § 438.2, capitation payment means a payment the State makes periodically to a contractor on behalf of each beneficiary enrolled under a contract and based on the actuarially sound capitation rate for the provision of services under the State plan. The State makes the payment regardless of whether the beneficiary receives services during the period covered by the payment. Sub-capitation payments refer to a payment a Medicaid/CHIP managed care plan makes periodically to a sub-capitated entity or sub-capitated network provider.¹ Capitation and sub-capitation payments do not include either partial or whole premium assistance payments for employer-sponsored insurance, marketplace qualified health plans, or other private commercial insurance at the market rate. See also CMS Technical Instructions: Reporting Sub-capitation Payments and Encounters Associated with Sub-capitation Payments from Managed Care Plans for more information.</u></p>	<u>2,500</u>

¹ <https://www.medicaid.gov/tmsis/dataguide/t-msis-coding-blog/cms-technical-instructions-reporting-sub-capitation-payments-and-encounters-associated-with-sub-capitation-payments-from-managed-care-plans/>

File Name	Record Segment Name	Record Identifier	Record Segment Definition	Record Segment Length
<u>Financial Transaction File</u>	<u>INDIVIDUAL-HEALTH-INSURANCE-PREMIUM-PAYMENT</u>	<u>FTX00003</u>	<p><u>A record segment to capture individual health insurance premium payments made by Medicaid or CHIP. Partial or full payment of a Medicaid or CHIP beneficiary's portion of employer-sponsored health insurance, qualified health plan, or other private commercial insurance premium payment for an individual. The payment may have been made directly to the insurance carrier or reimbursed directly to the policy owner. Premium assistance payments may not be recouped from a beneficiary or policy holder. For Medicaid, individual health insurance premium payments have been covered under the authority of SSA 1905(a), 1906A, or an 1115 demonstration waiver. For Medicaid, individual health insurance premium payments are typically reported to the MBES CMS-64 form category 18E. For CHIP, individual health insurance premium assistance payments have been covered under the authority of SSA 2105(c)(3) or an 1115 demonstration waiver. For CHIP individual health insurance premium assistance payments have typically been reported to the CBES CMS-21 form category 1.A and 1.C which can represent either CHIP health insurance premium assistance payments or CHIP capitation payments - only the CHIP health insurance premium assistance payments made should be reported in a FTX00003 segment.</u></p>	<u>2,500</u>

File Name	Record Segment Name	Record Identifier	Record Segment Definition	Record Segment Length
<u>Financial Transaction File</u>	<u>GROUP-INSURANCE- PREMIUM-PAYMENT</u>	<u>FTX00004</u>	<p><u>A record segment to capture group insurance premium payments made by Medicaid or CHIP. Partial or full payment of a Medicaid or CHIP beneficiary's portion of employer-sponsored health insurance, qualified health plan, or other private commercial insurance premium payment for group coverage. The payment may have been made directly to the insurance carrier or reimbursed directly to the policy owner. Premium assistance payments may not be recouped from a beneficiary or policy holder. For Medicaid, group health insurance premium payments have been covered under the authority of SSA 1905(a), 1906, 1906A, or an 1115 demonstration waiver. For Medicaid, group health insurance premium payments have typically been reported to the MBES CMS-64 form category 18C or 18E. For CHIP, group health insurance premium assistance payments have been covered under the authority of SSA 2105(c)(3) or an 1115 demonstration waiver. For CHIP group health insurance premium payments have typically been reported to the CBES CMS-21 form category 1.A and 1.C which can represent either CHIP health insurance premium assistance payments or CHIP capitation payments - only the CHIP health insurance premium assistance payments made should be reported in a FTX00003 segment.</u></p>	<u>2,500</u>

File Name	Record Segment Name	Record Identifier	Record Segment Definition	Record Segment Length
<u>Financial Transaction File</u>	<u>COST-SHARING-OFFSET</u>	<u>FTX00005</u>	<p><u>A record segment to capture cost sharing offsets. Cost sharing offsets are any cost sharing (e.g., Medicaid or CHIP beneficiary premiums) collected by either the state Medicaid or CHIP agencies (or their representatives) directly from beneficiaries. This type of cost-sharing does not go to a health care provider for services rendered. The federal regulation for these offsets can be found at 42 CFR 447.55 (or 1916) and 42 CFR 457.510. For CHIP these are reported to the CBES CMS-21 form category 1.B and 1.D.</u></p>	<u>2,500</u>

File Name	Record Segment Name	Record Identifier	Record Segment Definition	Record Segment Length
<u>Financial Transaction File</u>	<u>VALUE-BASED-PAYMENT</u>	<u>FTX00006</u>	<p><u>A record segment to capture value-based payments. Value-based payments or recoupments are made under value-based payment (VBP) agreements, including Medicaid Shared Savings Payments. A value-based payment may be made by a state Medicaid or CHIP agency to a fee-for-service (FFS) provider or by a managed care plan or sub-capitated entity to a managed care provider. Payments made from managed care plans (MCOs, PIHPs, or PAHPs) to providers under value-based payment (VBP) agreements can either be directed as part of the managed care plan's contract by the state as a state directed payment (SDP) under 42 CFR 438.6(c) or offered independently of the managed care plan's contract with the state. A value-based payment may also be made by a managed care plan to a provider or a sub-capitated entity. Value-based payments captured by this T-MSIS record segment do not include incentive payments as defined by 42 CFR 438.6(a) or (b), which are incentive or withholds paid by the state to the managed care plan for the managed care plan's performance. Value-based payments are not subject to UPL.²</u></p>	<u>2,500</u>

² <https://www.medicaid.gov/sites/default/files/2020-09/smd20004.pdf>

File Name	Record Segment Name	Record Identifier	Record Segment Definition	Record Segment Length
<u>Financial Transaction File</u>	<u>STATE-DIRECTED-PAYMENT-SEPARATE-PAYMENT-TERM</u>	<u>FTX00007</u>	<p><u>A record segment to capture State Directed Payment Separate Payment Term payments. All state directed payments, which are contractual obligations where states direct Medicaid managed care plans' expenditures for services under the contract, must be incorporated into all applicable managed care contract(s) and described in all applicable rate certification(s) as noted in 42 C.F.R. § 438.7(b)(6).³ As part of the Medicaid Managed Care Rate Development Guide, CMS provided guidance on two ways that states could incorporate state directed payments – either through adjustments to the base capitation rates as an adjustment to the rate or through a separate payment term.⁴ This segment is meant to capture payments made from the State to the Medicaid managed care plan (MCO, PIHP, or PAHP) for SDPs incorporated through separate payment terms. These payments are aggregate payments (not beneficiary or service specific.) This field should not capture payments made from the managed care plan to providers in compliance with an SDP contractual obligation.</u></p>	<u>2,500</u>

³ <https://www.medicaid.gov/Federal-Policy-Guidance/Downloads/smd21001.pdf>

⁴ <https://www.medicaid.gov/medicaid/managed-care/guidance/rate-review-and-rate-guides/index.html>

File Name	Record Segment Name	Record Identifier	Record Segment Definition	Record Segment Length
<u>Financial Transaction File</u>	<u>COST-SETTLEMENT-PAYMENT</u>	<u>FTX00008</u>	<p><u>A record segment to capture cost settlement payments. A cost settlement payment is an aggregate monthly, quarterly, bi-annual, or annual reconciliation of interim payments to the final cost amount for an otherwise fee-for-service (FFS) provider paid under a reconciled cost methodology as part of the base reimbursement methodology for services. If costs are reconciled on a claim-by-claim basis, then the reconciliation may be reflected as adjustments to each original fee-for-service claim rather than here as an aggregate cost settlement. If cost settlement payment is made in aggregate (not beneficiary or service specific) at the provider-level, then it would be reported to this segment. Upper payment limit (UPL) regulations apply to cost settlements made to providers who are subject to the UPL (e.g., hospitals, outpatient hospital settings, nursing facilities, clinics, intermediate care facilities⁵, and psychiatric residential treatment facilities⁶). UPL regulations may not apply to some types of cost settlements, such as those for school-based services⁷, Federally Qualified Health Clinics (FQHC), or rural health clinics⁸. Cost settlement for FFS FQHCs are reported to this type of transaction, rather than the FQHC Wrap Payments transaction type which is only for FQHCs paid by managed care plans.</u></p>	<u>2,500</u>

⁵ <https://www.macpac.gov/subtopic/supplemental-payments/>
https://www.medicaid.gov/medicaid/finance/payment-limit-demonstrations/upper-payment-limit-fags/index.html?search_api_fulltext=ID%3A92241&sort_by=field_faq_date&sort_order=DESC

⁶ <https://www.medicaid.gov/faq/how-psychiatric-residential-treatment-facility-prtf-upper-payment-limit-upl-different-other-institutional-upls/index.html>

File Name	Record Segment Name	Record Identifier	Record Segment Definition	Record Segment Length
Financial Transaction File	FQHC-WRAP-PAYMENT	FTX00009	<p>A record segment to capture FQHC wrap payments. An FQHC wrap payment is an additional payment to Federally Qualified Health Centers (FQHC) or rural health clinics (RHC) for the difference between what is paid pursuant to a contract between the center or clinic and a managed care entity and the prospective payment system (PPS) rate if the rate paid under the contract does not match the PPS rate for the same service. FQHC payments are not subject to an upper payment limit. They are separate FQHC payments that the state is obligated to make under the statute. Sometimes these FQHC wrap payments are paid by the state directly to the provider. Sometimes they are paid by the state to the managed care plan to be distributed to the FQHC provider(s). Either approach should be reported to this segment. If the FQHC wrap payment is paid by the state directly to the provider and combined with the provider's fee-for-service (FFS) cost settlement, then the entire payment should be mapped to the Cost Settlement transaction only.</p>	2,500

https://www.medicaid.gov/medicaid/finance/payment-limit-demonstrations/upper-payment-limit-faqs/index.html?search_api_fulltext=ID%3A92416&sort_by=field_faq_date&sort_order=DESC

⁷ <https://www.medicaid.gov/federal-policy-guidance/downloads/sbscib081820222.pdf>

⁸ <https://www.medicaid.gov/medicaid/downloads/upl-guidance-clinic-service-2nd-update-4-9-2015.pdf>

File Name	Record Segment Name	Record Identifier	Record Segment Definition	Record Segment Length
<u>Financial Transaction File</u>	<u>MISCELLANEOUS-PAYMENT</u>	<u>FTX00095</u>	<u>A record segment to capture any other miscellaneous payment transaction that is not explicitly excluded from T-MSIS reporting or does not meet the definition of and was therefore not mapped to any other specific transaction type must be reported to this financial transaction segment type. CMS will periodically review the transactions mapped to this segment type and assess the need to create new specific financial transaction types. Financial transactions excluded from T-MSIS are administrative costs defined by CMS-64.10 categories of service, other than for NEMT, and certain types of provider-level medical assistance payments that are tracked at the provider level by other CMS systems.</u>	<u>2,500</u>
<u>Managed Care Plan Information File</u>	<u>FILE-HEADER-RECORD-MANAGED-CARE</u>	<u>MCR00001</u>	<u>A record segment containing metadata necessary to identify the file itself, when it was created and the number of records it contains.</u>	<u>1,000</u>
<u>Managed Care Plan Information File</u>	<u>MANAGED-CARE-MAIN</u>	<u>MCR00002</u>	<u>A record segment to capture basic, generally static information about a managed care entity.</u>	<u>1,000</u>
<u>Managed Care Plan Information File</u>	<u>MANAGED-CARE-LOCATION-AND-CONTACT-INFO</u>	<u>MCR00003</u>	<u>A record segment to capture addresses, phone numbers, fax numbers, and email addresses of the managed care organization.</u>	<u>1,000</u>
<u>Managed Care Plan Information File</u>	<u>MANAGED-CARE-SERVICE-AREA</u>	<u>MCR00004</u>	<u>A record segment to capture the zip codes, counties, or other geographic descriptors that define the managed care entity's service area.</u>	<u>1,000</u>
<u>Managed Care Plan Information File</u>	<u>MANAGED-CARE-OPERATING-AUTHORITY</u>	<u>MCR00005</u>	<u>A record segment to capture information about the operating authority, waivers, and demonstrations under which a managed care entity is contracted with the state.</u>	<u>1,000</u>

File Name	Record Segment Name	Record Identifier	Record Segment Definition	Record Segment Length
<u>Managed Care Plan Information File</u>	<u>MANAGED-CARE-PLAN-POPULATION-ENROLLED</u>	<u>MCR00006</u>	<u>A record segment to capture the identity of the Medicaid/CHIP eligibility groups that the managed care entity is authorized to enroll.</u>	<u>1,000</u>
<u>Managed Care Plan Information File</u>	<u>MANAGED- CARE-ACCREDITATION-ORGANIZATION</u>	<u>MCR00007</u>	<u>A record segment to capture information concerning the accreditations that the managed care entity has.</u>	<u>1,000</u>
<u>Managed Care Plan Information File</u>	<u>MANAGED-CARE-PLAN-ID</u>	<u>MCR00010</u>	<u>A record segment to capture information concerning the ID(s) associated with a managed care plan.</u>	<u>1,000</u>
<u>Provider File</u>	<u>FILE-HEADER-RECORD-PROVIDER</u>	<u>PRV00001</u>	<u>A record segment containing metadata necessary to identify the file itself, when it was created and the number of records it contains.</u>	<u>1,100</u>
<u>Provider File</u>	<u>PROV-ATTRIBUTES-MAIN</u>	<u>PRV00002</u>	<u>A record segment to capture basic, generally static information about each provider. A provider is an individual person (medical or non-medical), a group of individuals, or an organization (e.g., institution, facility, agency, hospital, nursing facility, home health agency, school, or transportation organization) that delivers or facilitates health-related treatments, health care services, or living supports.</u>	<u>1,100</u>

File Name	Record Segment Name	Record Identifier	Record Segment Definition	Record Segment Length
<u>Provider File</u>	<u>PROV-LOCATION-AND-CONTACT-INFO</u>	<u>PRV00003</u>	<u>A record segment to capture addresses, phone numbers, and email addresses of the provider. Each PROV-LOCATION-AND-CONTACT-INFO record segment represents the set of contact information for a single provider location. The state can enter as many sets of contact information (i.e., multiple PROV-LOCATION-AND-CONTACT-INFO record segments) as it considers necessary. The value selected for the ADDR-TYPE field describes the type of contact information on that specific record (e.g., provider service location, provider billing address, etc.). The PROV-LOCATION-ID differentiates one PROV-LOCATION-AND-CONTACT-INFO record segment from another when the ADDR-TYPE value on both records is the same.</u>	<u>1,100</u>
<u>Provider File</u>	<u>PROV-LICENSING-INFO</u>	<u>PRV00004</u>	<u>A record segment to capture licensing and accreditation information relevant to the provider.</u>	<u>1,100</u>
<u>Provider File</u>	<u>PROV-IDENTIFIERS</u>	<u>PRV00005</u>	<u>A record segment to capture the identifiers assigned to the provider entity by various governmental, professional, and payer entities.</u>	<u>1,100</u>
<u>Provider File</u>	<u>PROV-TAXONOMY-CLASSIFICATION</u>	<u>PRV00006</u>	<u>A record segment to classify the provider into areas of specialty, as well as the authorized categories of service for which the provider entity has been authorized by the state to render to Medicaid/CHIP eligibles.</u>	<u>1,100</u>
<u>Provider File</u>	<u>PROV-MEDICAID-ENROLLMENT</u>	<u>PRV00007</u>	<u>A record segment to capture the provider's periods of participation in the state's Medicaid/CHIP programs, and the reason for a change in enrollment status.</u>	<u>1,100</u>

File Name	Record Segment Name	Record Identifier	Record Segment Definition	Record Segment Length
<u>Provider File</u>	<u>PROV-AFFILIATED-GROUPS</u>	<u>PRV00008</u>	<u>A record segment to capture a provider's relationship(s) with other provider(s).</u>	<u>1,100</u>
<u>Provider File</u>	<u>PROV-AFFILIATED-PROGRAMS</u>	<u>PRV00009</u>	<u>A record segment to capture the Medicaid/CHIP health plans, waivers, health home entities, etc. that the provider entity is associated with.</u>	<u>1,100</u>
<u>Provider File</u>	<u>PROV-BED-TYPE-INFO</u>	<u>PRV00010</u>	<u>A record segment to capture the number of beds available for various categories of bed at provider entities that are facilities.</u>	<u>1,100</u>
<u>Third-party Liability File</u>	<u>FILE-HEADER-RECORD-TPL</u>	<u>TPL00001</u>	<u>A record segment containing metadata necessary to identify the file itself, when it was created and the number of records it contains.</u>	<u>900</u>
<u>Third-party Liability File</u>	<u>TPL-MEDICAID-ELIGIBLE-PERSON-MAIN</u>	<u>TPL00002</u>	<u>A record segment to capture basic, generally static information to identify Medicaid/CHIP enrollees for whom third party funds may be available to offset some or all their Medicaid/CHIP costs.</u>	<u>900</u>
<u>Third-party Liability File</u>	<u>TPL-MEDICAID-ELIGIBLE-PERSON-HEALTH-INSURANCE-COVERAGE-INFO</u>	<u>TPL00003</u>	<u>A record segment to capture insurance policy information needed to facilitate pursuit of the third-party liability.</u>	<u>900</u>
<u>Third-party Liability File</u>	<u>TPL-MEDICAID-ELIGIBLE-PERSON-HEALTH-INSURANCE-COVERAGE-CATEGORIES</u>	<u>TPL00004</u>	<u>A record segment to capture TPL insurance coverage information to support the applicability assessment of the third-party insurance coverage to the Medicaid/CHIP costs incurred on behalf of the Medicaid/CHIP enrollee.</u>	<u>900</u>
<u>Third-party Liability File</u>	<u>TPL-MEDICAID-ELIGIBLE-OTHER-THIRD-PARTY-COVERAGE-INFORMATION</u>	<u>TPL00005</u>	<u>A record segment to flag Medicaid/CHIP enrollees who potentially have non-insurance sources of funds that could be used to offset Medicaid/CHIP expenditures.</u>	<u>900</u>
<u>Third-party Liability File</u>	<u>TPL-ENTITY-CONTACT-INFORMATION</u>	<u>TPL00006</u>	<u>A record segment to capture addresses and phone numbers of the entity providing TPL insurance coverage.</u>	<u>900</u>

Record Segment Relationships Figures

Claim IP File – Record Segment Relationships

Diagram 1: Claim IP File – Claim Record Segment Relationships

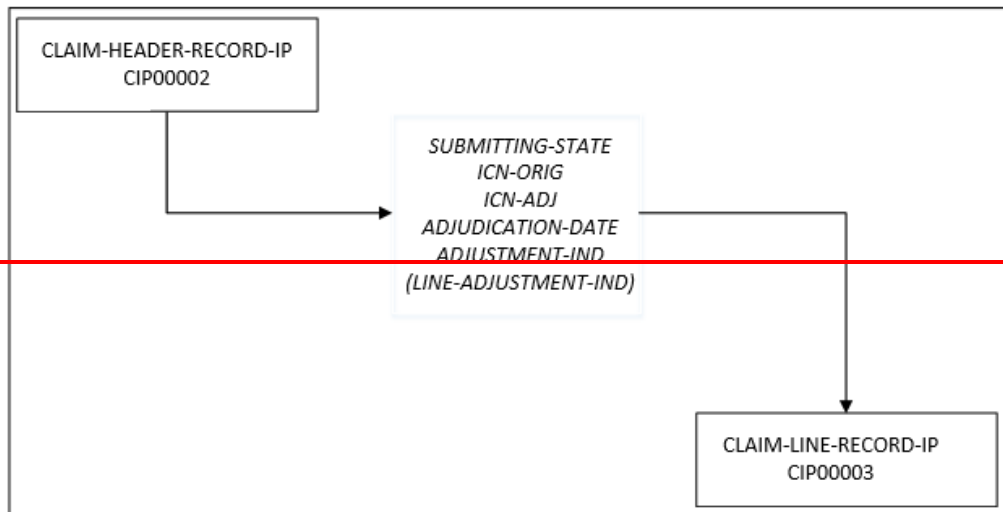
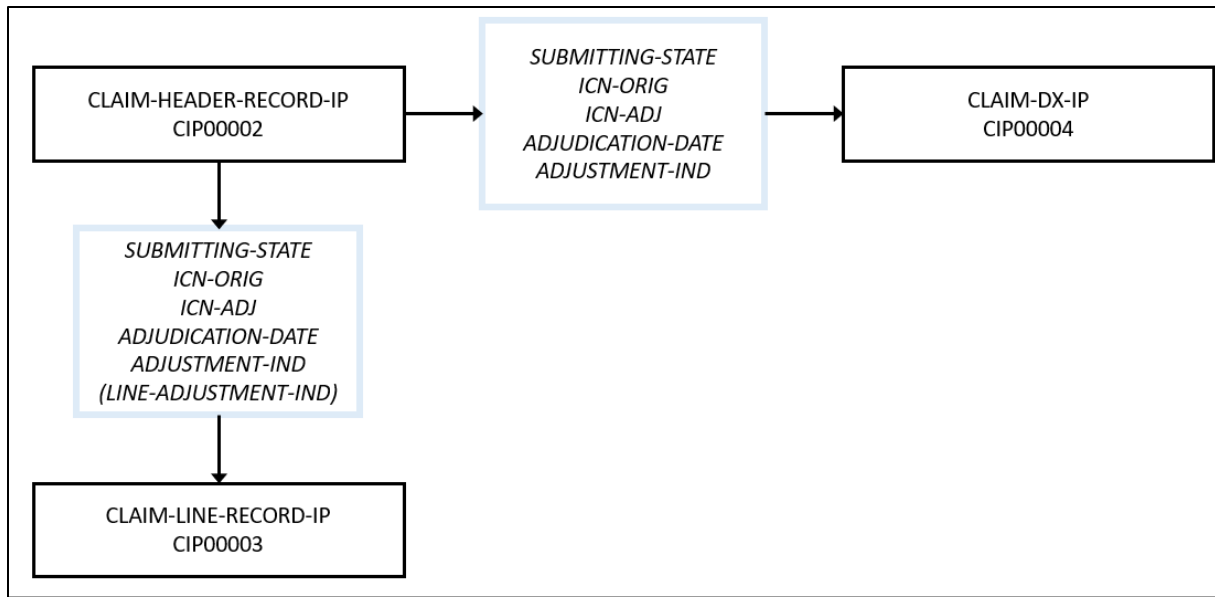

Figure 1: Claim IP File – Claim Record Segment Relationships



Description of DiagramFigure 1:

Each claim record in the T-MSIS inpatient claims file is composed of twothree types of record segments: One claim header segment, one or more claim diagnosis segments, and multipleone or more claim line segments. Each claim diagnosis segment and claim line segment joins to its corresponding claim header segment on the following fourfive data elements:

1. SUBMITTING-STATE
2. ICN-ORIG
3. ICN-ADJ
4. ADJUDICATION-DATE
5. ADJUSTMENT-IND (joins to LINE-ADJUSTMENT-IND for claim line segments)

Claim LT File – Claim Record Segment Relationships

DiagramFigure 2: Claim LT File – Claim Record Segment Relationships

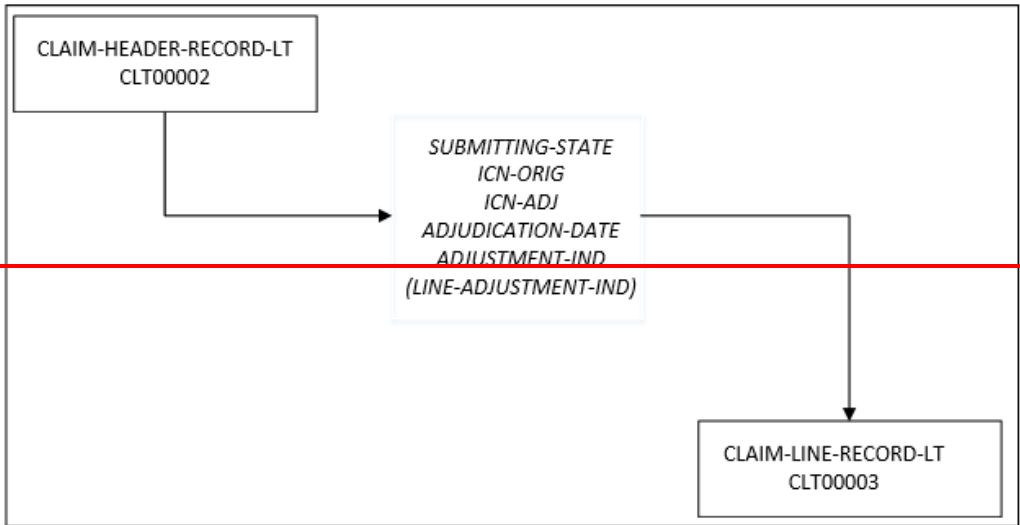
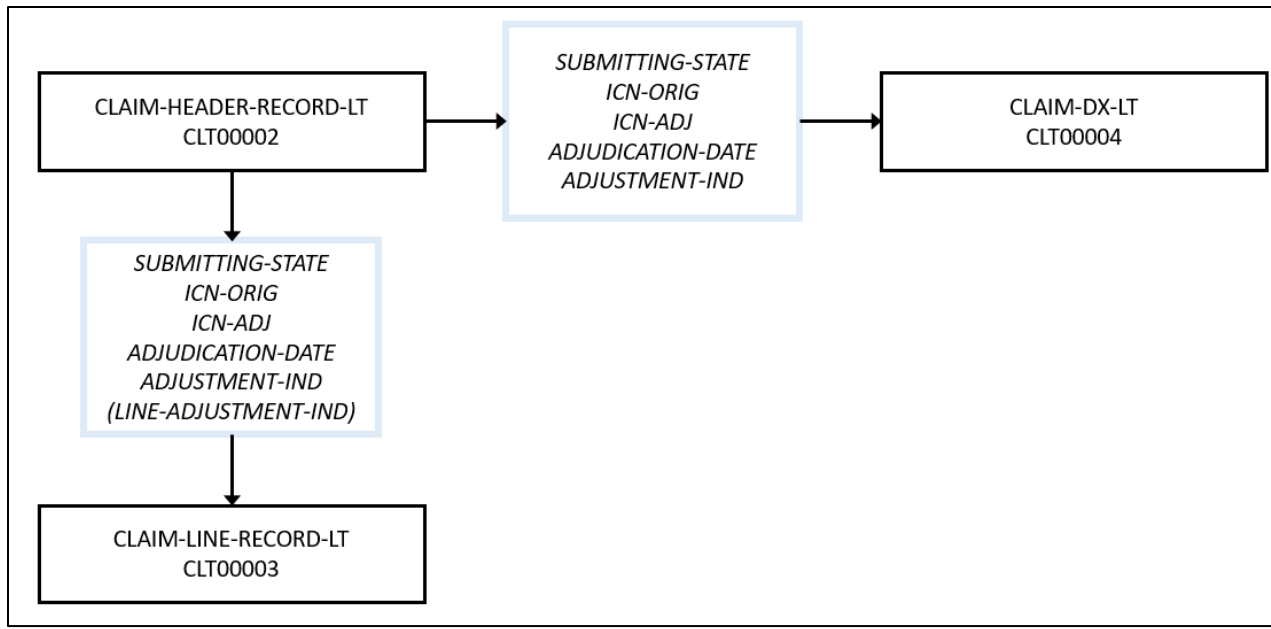

Figure 2: Claim LT File — Claim Record Segment Relationships



Description of Diagram Figure 2:

Each claim record in the T-MSIS long-term care claims file is composed of two types of record segments: One claim header segment, one or more claim diagnosis segments, and multiple one or more claim line segments. Each claim diagnosis segment and claim line segment joins to its corresponding claim header segment on the following four data elements:

1. SUBMITTING-STATE
2. ICN-ORIG
3. ICN-ADJ
4. ADJUDICATION-DATE
5. ADJUSTMENT-IND (joins to LINE-ADJUSTMENT-IND for claim line segments)

Claim OT File – Claim Record Segment Relationships

Diagram *Figure 3: Claim OT File – Claim Record Segment Relationships*

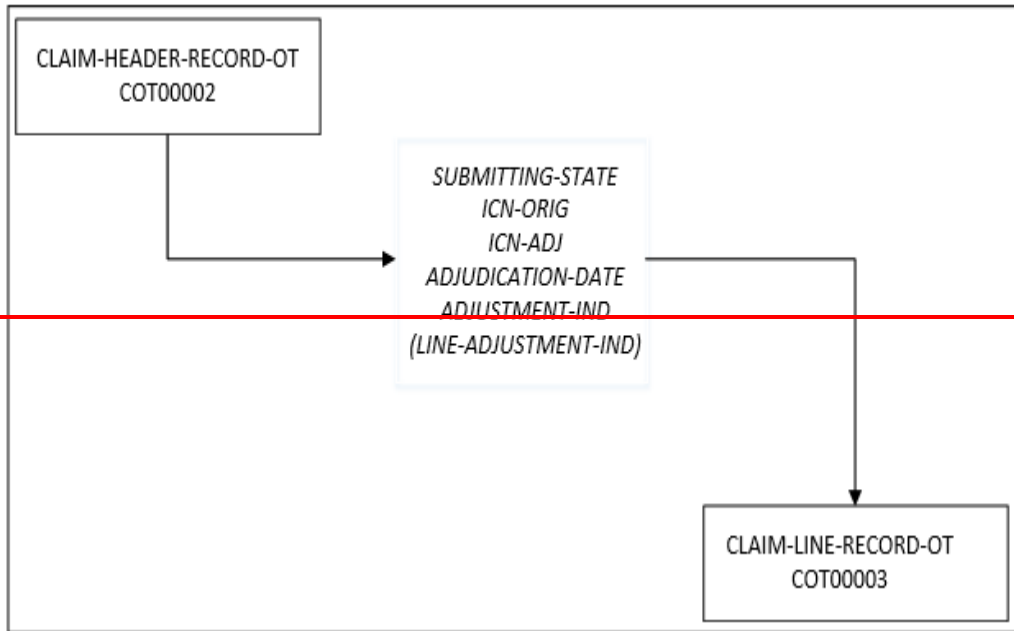
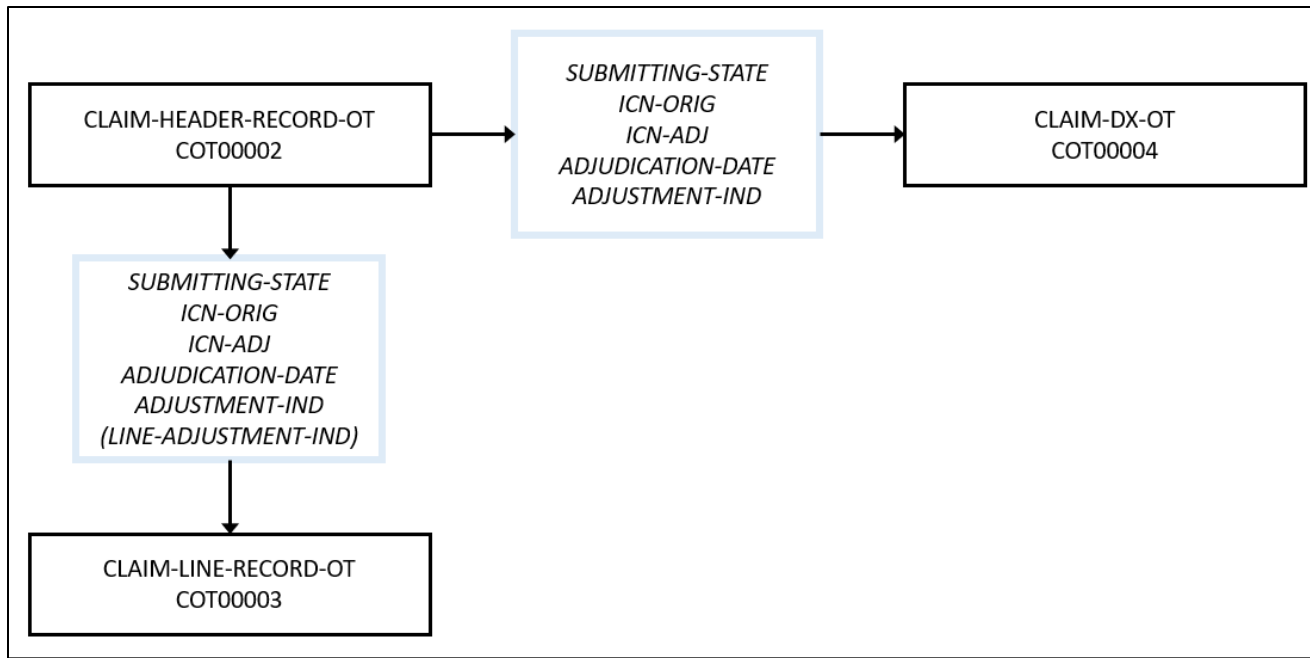

Figure 3: Claim OT File – Claim Record Segment Relationships



Description of ~~Diagram~~Figure 3:

Each claim record in the T-MSIS other claims file is composed of ~~two~~three types of record segments: One claim header segment, one or more claim diagnosis segments, and ~~multiple~~one or more claim line segments. Each claim diagnosis segment and claim line segment joins to its corresponding claim header segment on the following ~~four~~five data elements:

1. SUBMITTING-STATE
2. ICN-ORIG
3. ICN-ADJ
4. ADJUDICATION-DATE
5. ADJUSTMENT-IND (joins to LINE-ADJUSTMENT-IND for claim line segments)

Claim RX File – Claim Record Segment Relationships

~~Diagram~~Figure 4: Claim RX File – Claim Record Segment Relationships

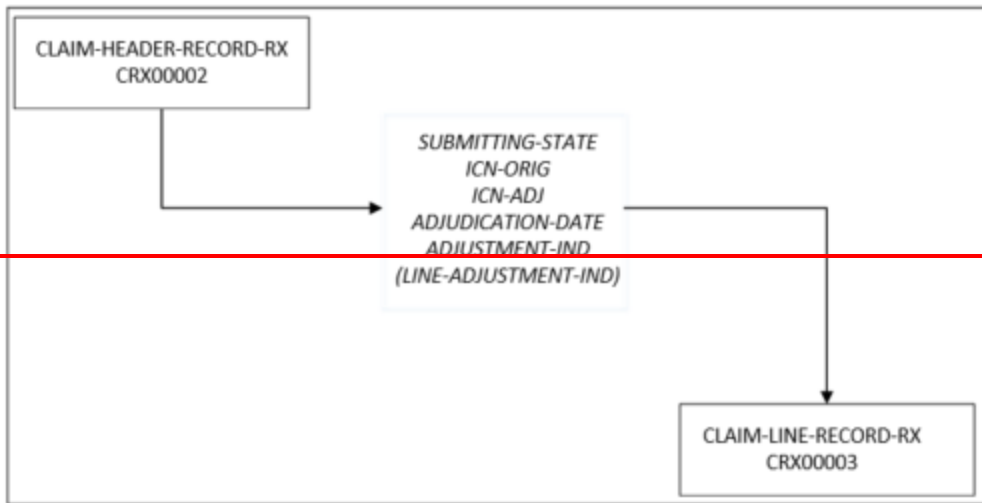
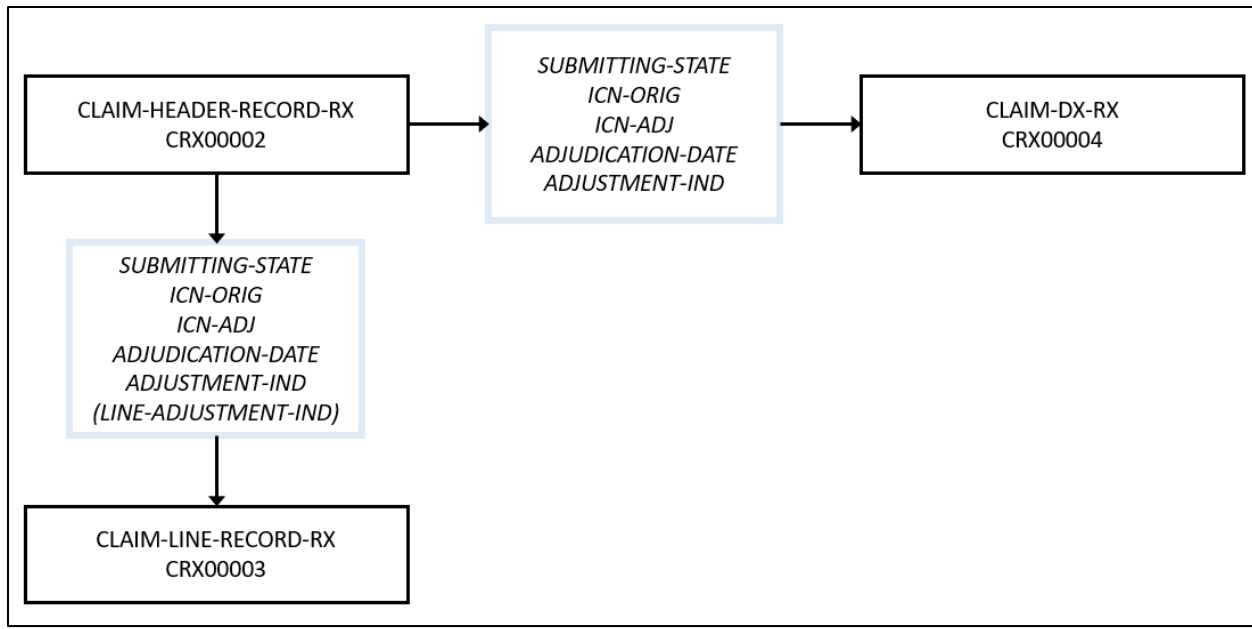

Figure 4: Claim RX File—Claim Record Segment Relationships



Description of ~~Diagram~~Figure 4:

Each claim record in the T-MSIS ~~prescription drug (RX)pharmacy~~ claims file is composed of ~~two~~three types of record segments: One claim header segment, ~~one or more claim diagnosis segments~~, and ~~multiple~~one or more claim line segments. Each claim ~~diagnosis segment and claim~~ line segment joins to its ~~corresponding~~ claim header segment on the following ~~four~~five data elements:

1. SUBMITTING-STATE
2. ICN-ORIG
3. ICN-ADJ
4. ADJUDICATION-DATE
5. ADJUSTMENT-IND (~~joins to~~ LINE-ADJUSTMENT-IND ~~for claim line segments~~)

Eligible File – Eligible Person Record Segment Relationships

Diagram Figure 5: Eligible File – Eligible Person Record Segment Relationships

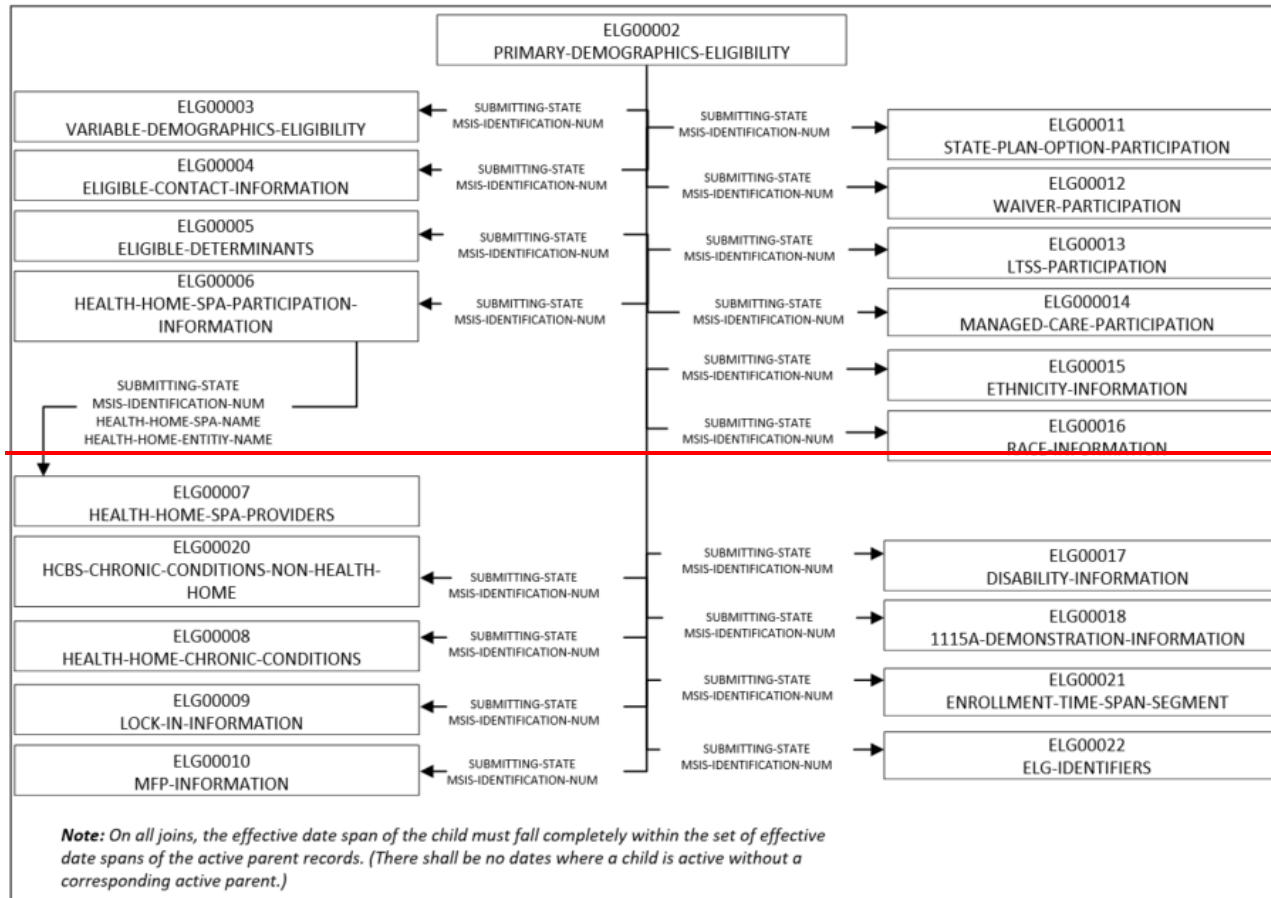
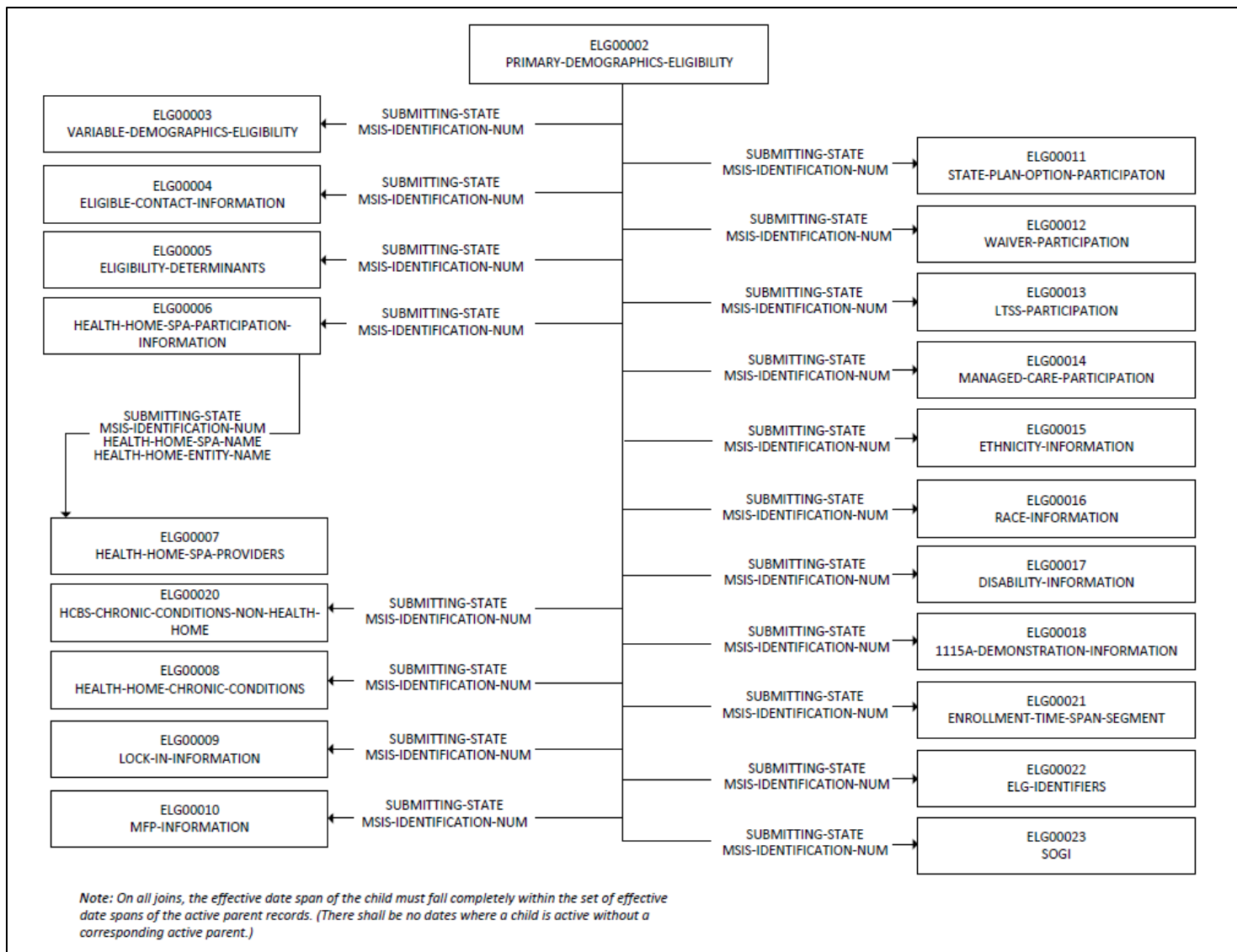

Figure 5: Eligible File – Eligible Person Record Segment Relationships



Description of **DiagramFigure 5:**

Each eligible person in T-MSIS has a record in the T-MSIS eligibility file. Each of these records is comprised of up to ~~twenty~~twenty-one different types of record segments. The PRIMARY-DEMOGRAPHICS-ELIGIBILITY (ELG00002) segment is the parent segment and all other segments, except for the HEALTH-HOME-SPA-PROVIDERS (ELG00007) segment, join to it on the following two data elements:

1. SUBMITTING-STATE
2. MSIS-IDENTIFICATION-NUM

The exception ~~to~~is the HEALTH-HOME-SPA-PROVIDERS (ELG00007) segment ~~is~~is a child of the HEALTH-HOME-SPA-PARTICIPATION-INFORMATION (ELG00006) segment and joins to it on:

1. SUBMITTING-STATE
2. MSIS-IDENTIFICATION-NUM
3. HEALTH-HOME-SPA-ID
4. HEALTH-HOME-ENTITY-NAME

Financial Transactions File – Record Segment Relationships

Figure 9: Financial Transactions File – FTX Record Segment Relationships

FILE-HEADER RECORD-FTX FTX00001	VALUE-BASED-PAYMENT FTX00006
INDIVIDUAL-CAPITATION-PMPM FTX00002	STATE-DIRECTED-PAYMENT-SEPARATE- PAYMENT-TERM FTX00007
INDIVIDUAL-HEALTH-INSURANCE- PREMIUM-PAYMENT FTX00003	COST-SETTLEMENT-PAYMENT FTX00008
GROUP-INSURANCE-PREMIUM-PAYMENT FTX00004	FQHC-WRAP-PAYMENT FTX00009
COST-SHARING-OFFSET FTX00005	MISCELLANEOUS-PAYMENT FTX00095

Description of Figure 9:

Unlike the other T-MSIS file types, ***the Financial Transactions file does not contain relationships among the segments.*** Each segment in this file represents a different type of financial transaction, except for the “miscellaneous” segment which can represent multiple types of financial transactions. The purpose of the “miscellaneous” segment is to represent financial transactions which are not common across states and/or occur in relatively low volumes within most states, as well as to provide a flexible mechanism for CMS and/or states to add new financial transactions in a much shorter time cycle than would be possible by adding an entirely new segment. The “miscellaneous” segment utilizes a generalized set of data elements and an expandable valid value list to distinguish different types of financial transactions from one another.

Managed Care File – Managed Care Entity Record Segment Relationships

Figure 2: Managed Care File – Managed Care Entity Record Segment Relationships

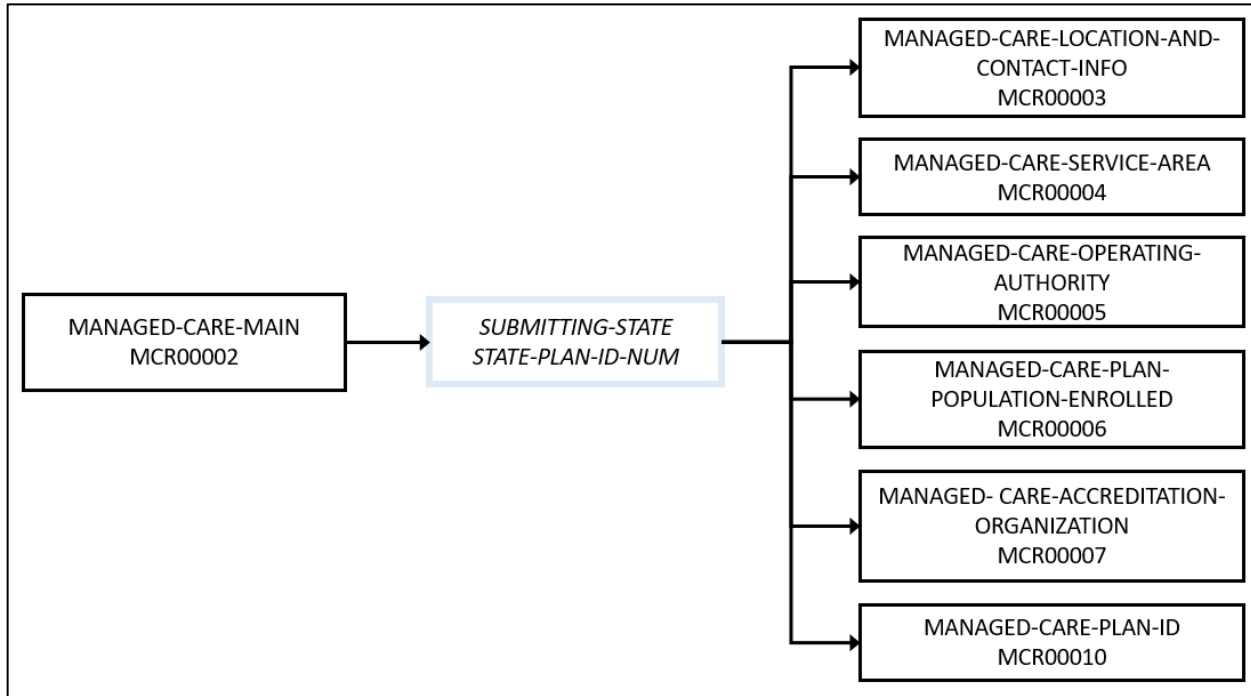

Description of Figure 7:

Each managed care entity in T-MSIS must have a record in the T-MSIS managed care file. Each managed care record is comprised of up to seven different types of record segments. The MANAGED-CARE-MAIN (MCR00002) segment is the parent segment to five segments: MANAGED-CARE-LOCATION-AND-CONTACT-INFO (MCR00003), MANAGED-CARE-SERVICE-AREA (MCR00004), MANAGED-CARE-OPERATING-AUTHORITY (MCR00005), MANAGED-CARE-PLAN-POPULATION-ENROLLED (MCR00006), MANAGED-CARE-ACCREDITATION-ORGANIZATION (MCR00007) and MANAGED-CARE-PLAN-ID (MCR00010) all of which join to MANAGED-CARE-MAIN and to each other on the following two data elements:

- SUBMITTING-STATE
- STATE-PLAN-ID-NUM

Provider File – Provider Record Segment Relationships

Diagram *Figure 6: Provider File – Provider Record Segment Relationships*

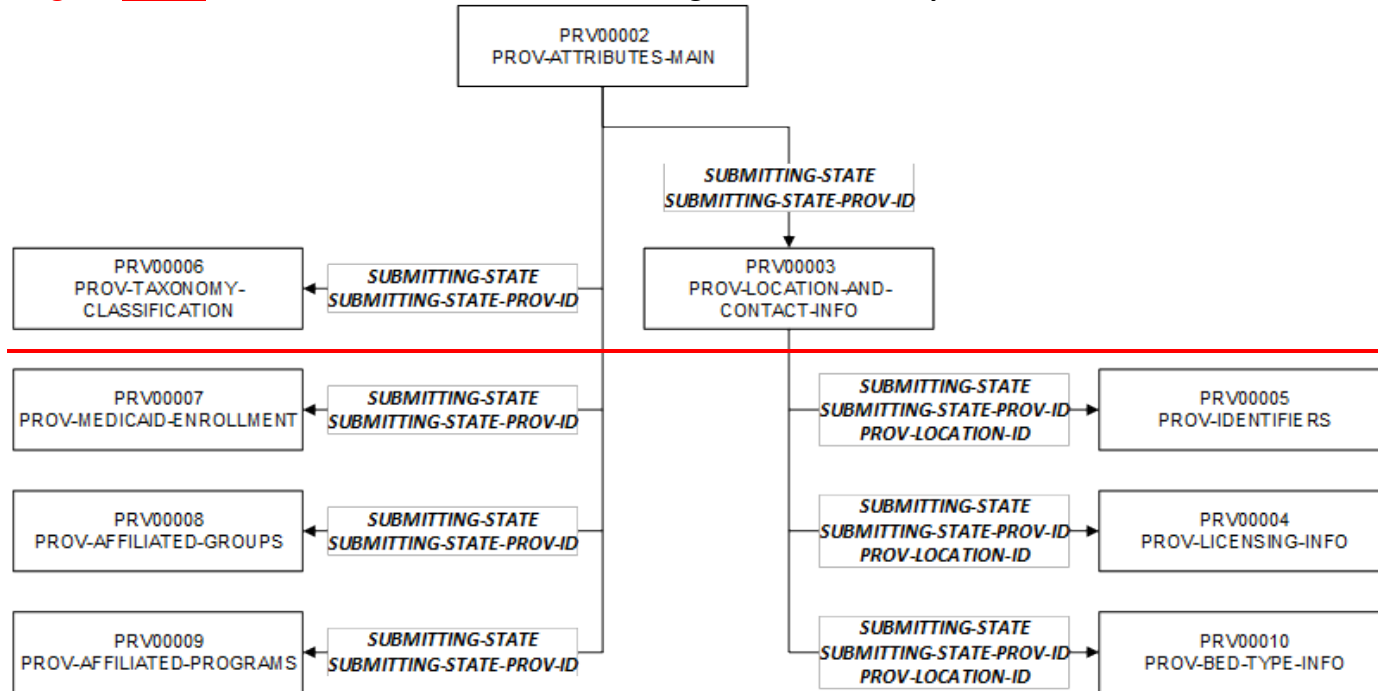
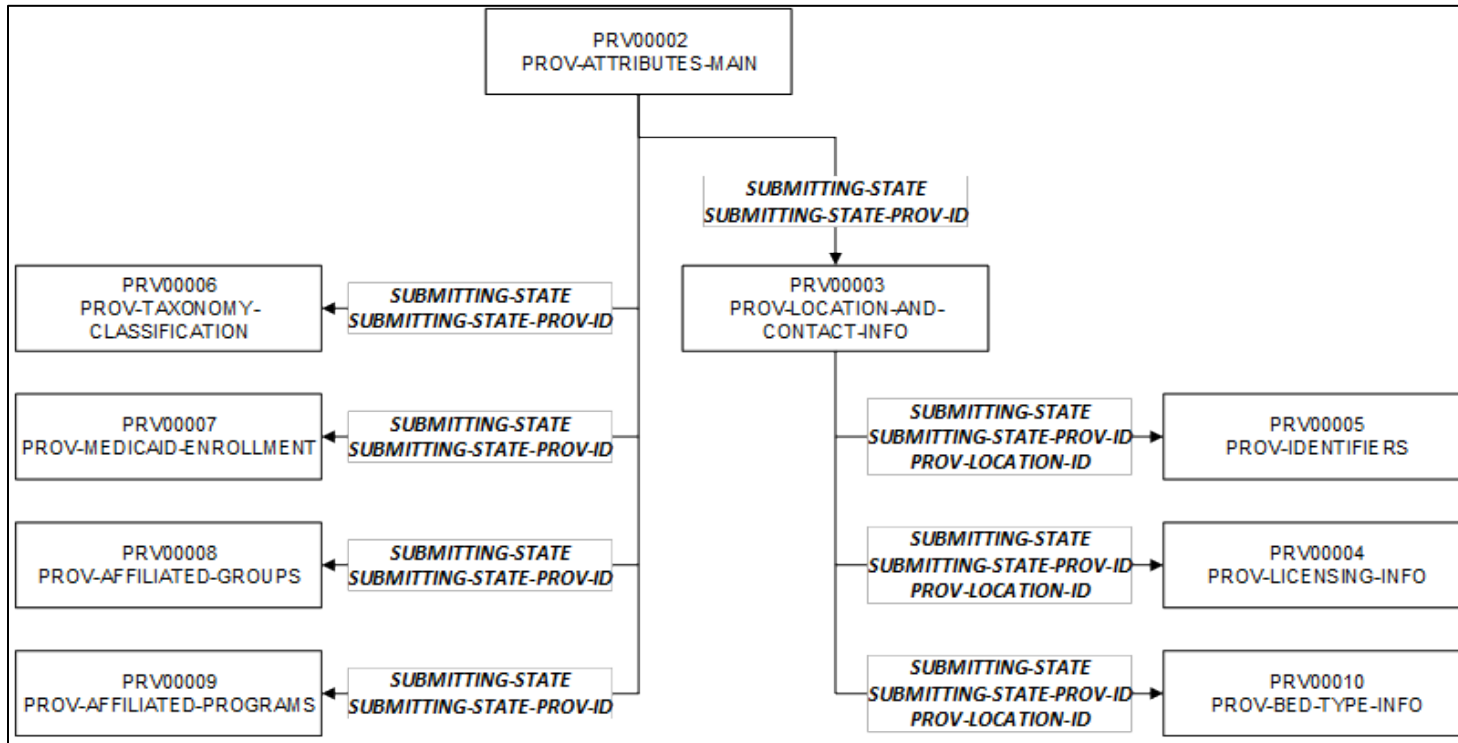

Figure 6: Provider File – Provider Record Segment Relationships



Description of ~~Diagram~~Figure 6:

Each provider in T-MSIS (regardless of whether the provider is a single individual, a group of practitioners, a facility, or a group of facilities) must have a record in the T-MSIS provider's file. Each provider record is comprised of up to nine different types of record segments. The PROV-ATTRIBUTES-MAIN (PRV00002) segment is the parent segment to five segments: PROV-TAXONOMY-CLASSIFICATION (PRV00006), PROV-MEDICAID-ENROLLMENT (PRV00007), PROV-AFFILIATED-GROUPS (PRV00008), PROV-AFFILIATED-PROGRAMS (PRV00009), and PROV-LOCATION-AND-CONTACT-INFO (PRV00003), all of which join to PROV-ATTRIBUTES-MAIN on the following two data elements:

1. SUBMITTING-STATE
2. SUBMITTING-STATE-PROV-ID

In addition, the PROV-LOCATION-AND-CONTACT-INFO (PRV00003) segment is a parent segment ~~in its own right~~ to three additional subordinate segments: PROV-IDENTIFIERS (PRV00005), PROV-LICENSING-INFO (PRV00004), PROV-BED-TYPE-INFO (PRV00010). These three segments join to the PROV-LOCATION-AND-CONTACT-INFO segment on:

1. SUBMITTING-STATE
2. SUBMITTING-STATE-PROV-ID
3. PROV-LOCATION-ID

~~Managed Care File — Managed Care Entity Record Segment Relationships~~

~~Diagram 7: Managed Care File — Managed Care Entity Record Segment Relationships~~

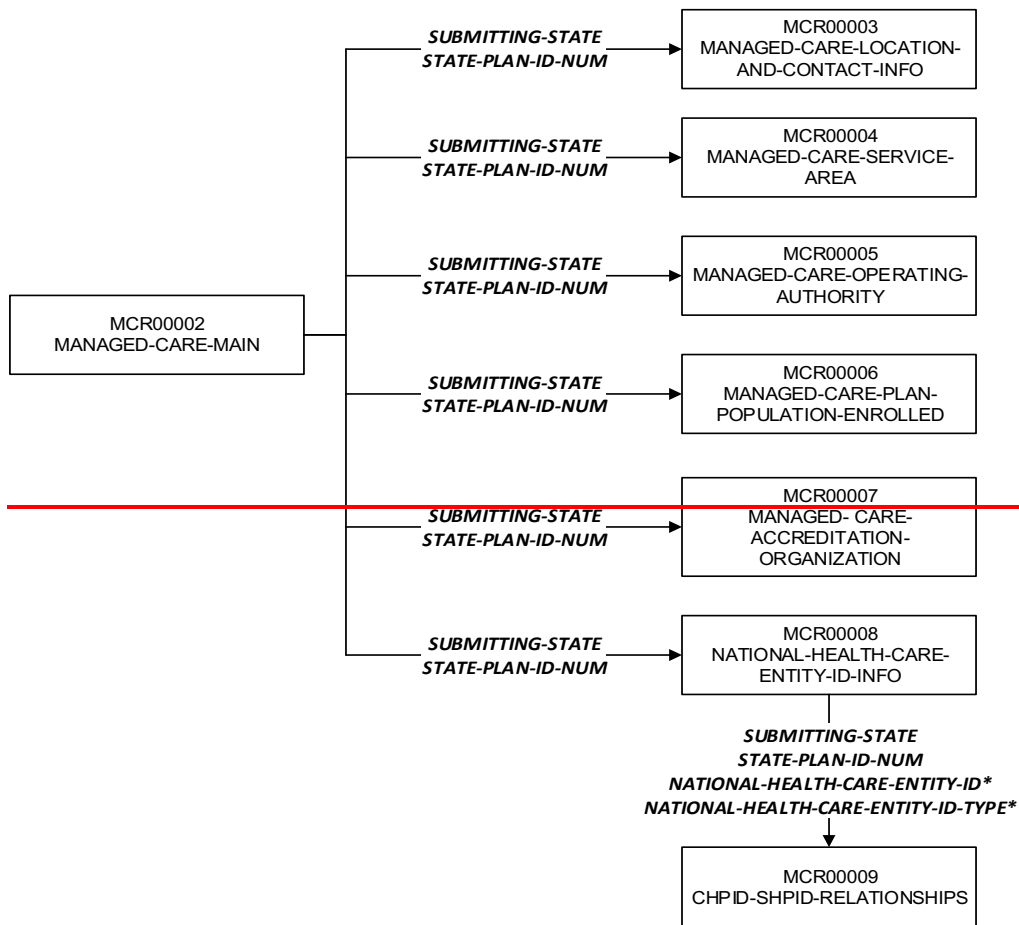

* = MCR00008.NATIONAL-HEALTH-CARE-ENTITY-ID would join to either MCR00009.CHPID or MCR00009.SHPID based on the value in MCR00008.NATIONAL-HEALTH-CARE-ENTITY-ID-TYPE.

Figure 7: Managed Care File – Managed Care Entity Record Segment Relationships

Description of Diagram 7:

Each managed care entity in T-MSIS must have a record in the T-MSIS managed care file. Each managed care record is comprised of up to eight different types of record segments. The MANAGED-CARE-MAIN (MCR00002) segment is the parent segment to six segments: MANAGED-CARE-LOCATION-AND-CONTACT-INFO (MCR00003), MANAGED-CARE-SERVICE-AREA (MCR00004), MANAGED-CARE-OPERATING-AUTHORITY

~~(MCR00005), MANAGED CARE PLAN POPULATION ENROLLED (MCR00006), MANAGED CARE ACCREDITATION ORGANIZATION (MCR00007), and NATIONAL HEALTH CARE ENTITY ID INFO (MCR00008), all of which join to PROV ATTRIBUTES MAIN on the following two data elements:~~

~~1. SUBMITTING STATE~~

~~2.1. STATE PLAN ID NUM~~

~~In addition, the NATIONAL HEALTH CARE ENTITY ID INFO (MCR00008) segment is a parent segment in its own right to the CHPID SHPID RELATIONSHIPS (MCR00009) segment, which joins to the NATIONAL HEALTH CARE ENTITY ID INFO segment on:~~

~~1. SUBMITTING STATE~~

~~2. STATE PLAN ID NUM~~

~~3. NATIONAL HEALTH CARE ENTITY ID*~~

~~4. NATIONAL HEALTH CARE ENTITY ID TYPE*.~~

~~* = MCR00008.NATIONAL HEALTH CARE ENTITY ID would join to either MCR00009.CHPID or MCR00009.SHPID based on the value in MCR00008.NATIONAL HEALTH CARE ENTITY ID TYPE.~~

Third-Party Liability (TPL) File – Record Segment Relationships

Diagram 8: Figure 3: Third-Party Liability (TPL) File – TPL Record Segment Relationships

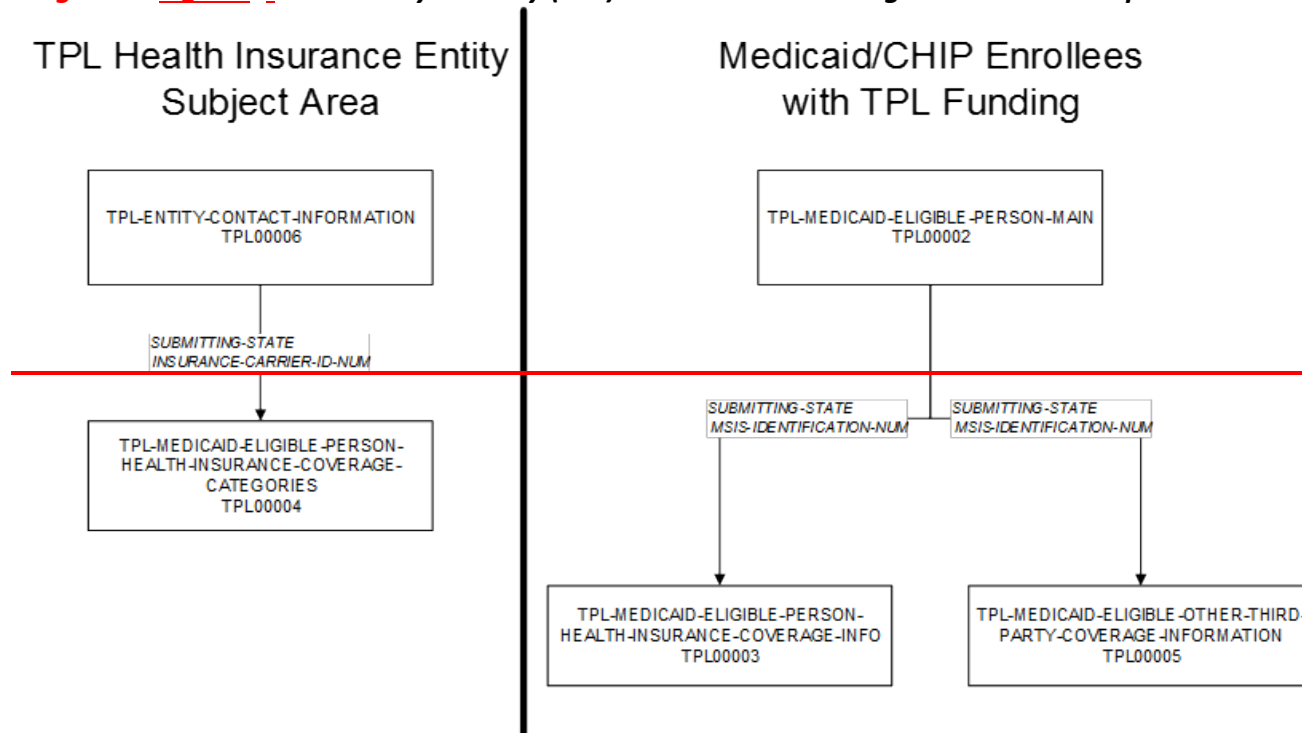
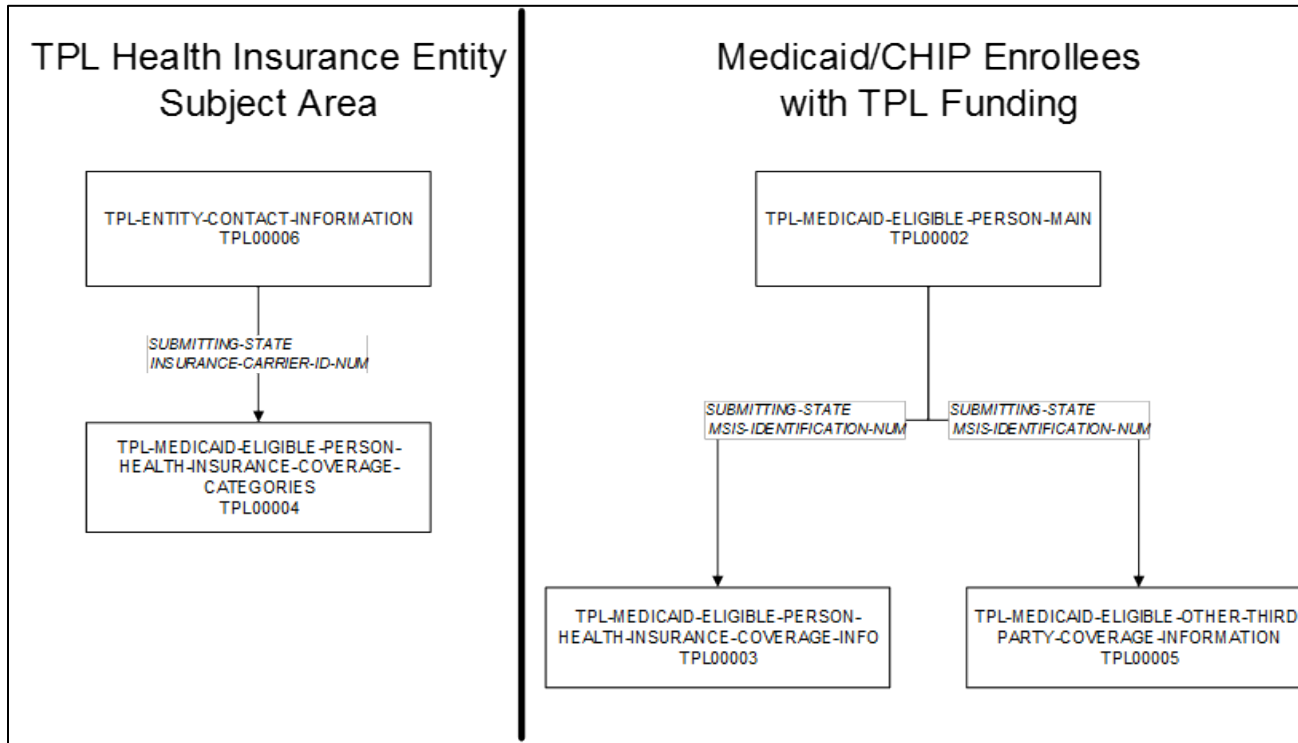

Figure 8: Third-Party Liability (TPL) File – TPL Record Segment Relationships



Description of ~~Diagram~~Figure 8:

Each instance of potential third-party liability for T-MSIS eligibles must have a record in the T-MSIS TPL file. There are **actually** two sets of information captured (called “subject areas”) in the TPL file: One set of records captures general information about non-Medicaid, non-Medicare health insurers, while the other set of records captures information about third party sources of funds that individual Medicaid/CHIP eligibles have.

TPL Health Insurance Entity Subject Area

Two types of record segments comprise the “TPL health insurance entity subject area:” the TPL-ENTITY-CONTACT-INFORMATION (TPL00006) and TPL-MEDICAID-ELIGIBLE-PERSON-HEALTH-INSURANCE-COVERAGE-CATEGORIES (TPL00004) segments. There is a one-to-many relationship between these segment types (one TPL-ENTITY-CONTACT-INFORMATION segment type to many TPL-MEDICAID-ELIGIBLE-PERSON-HEALTH-

INSURANCE-COVERAGE-CATEGORIES segments). The TPL-MEDICAID-ELIGIBLE-PERSON-HEALTH-INSURANCE-COVERAGE-CATEGORIES segment joins to the TPL-ENTITY-CONTACT-INFORMATION segment on two fields:

1. SUBMITTING-STATE
2. INSURANCE-CARRIER-ID-NUM

Medicaid/CHIP Enrollees with TPL Funding Subject Area

Three types of segments make up the “Medicaid/CHIP Enrollees with TPL Funding Subject Area.” The TPL-MEDICAID-ELIGIBLE-PERSON-MAIN (TPL00002) segment type is the parent segment, with TPL-MEDICAID-ELIGIBLE-PERSON-HEALTH-INSURANCE-COVERAGE-INFO (TPL00003) and TPL-MEDICAID-ELIGIBLE-OTHER-THIRD-PARTY-COVERAGE-INFORMATION (TPL00005) being the subordinate segments. The two subordinate segments join to TPL-MEDICAID-ELIGIBLE-PERSON-MAIN (TPL00002) segment on:

1. SUBMITTING-STATE
2. MSIS-IDENTIFICATION-NUM

PRA Disclosure Statement

~~The Transformed Medicaid Statistical Information System (T-MSIS) is used to assist the Centers for Medicare & Medicaid Services (CMS) with monitoring and oversight of Medicaid and CHIP programs, to enable evaluation of demonstrations under section 1115 of the Social Security Act and to calculate quality measures and other metrics, including those reported through the new Medicaid and CHIP Scoreboard. Section 4735 of the Balanced Budget Act of 1997 included a statutory requirement for states to submit claims data, enrollee encounter data, and supporting information. Section 6504 of the Affordable Care Act strengthened this provision by requiring states to include data elements the Secretary determines necessary for program integrity, program oversight, and administration. Under the Privacy Act of 1974 any personally identifying information obtained will be kept private to the extent of the law. According to the Paperwork Reduction Act of 1995, no persons are required to respond to a collection of information unless it displays a valid OMB control number. The valid OMB control number for this information collection is 0938-0345 (Expires: 07/31/2022). The time required to complete this information collection is estimated to average 10 hours per response, including the time to review instructions, search existing data resources, gather the data needed, and complete and review the information collection. If you have comments concerning the accuracy of the time estimate(s) or suggestions for improving this form, please write to: CMS, 7500 Security Boulevard, Attn: PRA Reports Clearance Officer, Mail Stop C4-26-05, Baltimore, Maryland 21244-1850.~~